



**76/77
Models**

911, Carrera 3.0 Turbo

**Tech-
nical
Specifi-
cations**



Contents

	Page
Important conversion factors and new units of measurement	6
Chassis/engine and transmission numbers, engine type designations, transmission type codes	7
 Engine	
Specifications for 1976/1977 models	12
Cylinder designation on 6 cylinder engine	16
Engine tolerance and wear limit survey	17
Crankshaft - standard and repair sizes	18
Crankcase, connecting rods	19
Weight groups of connecting rods	20
Matching intermediate shaft and crankcase	21
Checking intermediate shaft gear	21
Intermediate shaft	22
Timing chain case	23
Camshaft housing, camshaft	24
Measuring sprockets for parallel alignment	25
Pistons and cylinders (sizes, weights and codes)	26
Cylinder sizes	27
Measuring pistons and cylinders	28
Valve dimensions	29
Valve guides (wear limits, installation size)	30
Specifications for installation of valve seat inserts	31
Installations lengths of valve springs	32
Camshafts, timing	34
Clutch drive plate	36
Important engine adjusting data	37
Spark plugs, battery charge condition	39
Tightening torque	40
 Fuel system	
Warm-up regulator, fuel injectors (K-Jetronic)	41
 Transmission	
Adjustment of drive pinion	42
Adjustment of ring gear	43
Manual transmission adjusting data	44

	Page
Sportomatic transmission adjusting data	45
Transmission tolerance survey	46
Tightening torque for manual transmission 915	48
Tightening torque for manual transmission 930	50
Tightening torque for sportomatic transmission	52
Specifications for sportomatic transmission	54

Front axle and steering

Specifications	55
Adjusting data and tolerances - height adjustment	56
Tightening torque	59

Rear axle

Specifications	62
Adjusting data and tolerances - height adjustment	62
Tightening torque	64

Brakes, wheels, tires

General data	65
Tandem brake master cylinder	68
Machining specifications and wear limits for brake discs and parking brake	70
Brake circuit failure indicator	72
Checking wheel rims, tire pressures	73
Rim and tire survey	74
Tightening torque for front and rear brakes	78

Electrical system

Fuse chart	80
Bulb chart	82

General technical data

Dimensions	83
Weights	83
Filling capacities	84
Performances, consumption of fuel and oil	85

Important conversion factors and new units of measurement

	Old units		New units
Pressure	tech. atmosphere at	(kp/cm ²)	Bar (bar)
Output	Horsepower	HP	Kilowatt (kW)
Force	Kilopond	kp	Newton (N)
Power	Kilopondmeter	kpm	Newtonmeter (Nm)

Conversion factors

at (kp/cm ²)	in bar	x 0.981
kp	in N	x 9.81
HP	in kW	x 0.736
kpm	in Nm	x 9.81
m/s	in km/h	x 3.6
at	in mm Hg	x 735.56
km/h	in mph (miles)	x 0.621
°F (Fahrenheit)	in °C	(°F - 32) x 0.555
l	in U.S. gal.	x 0.264
l	in Imp. gal.	x 0.22

The conversion factor 10 is applied for the conversion of tightening torque from kpm to Nm. This is more than sufficient for shop practice.

Chassis numbers

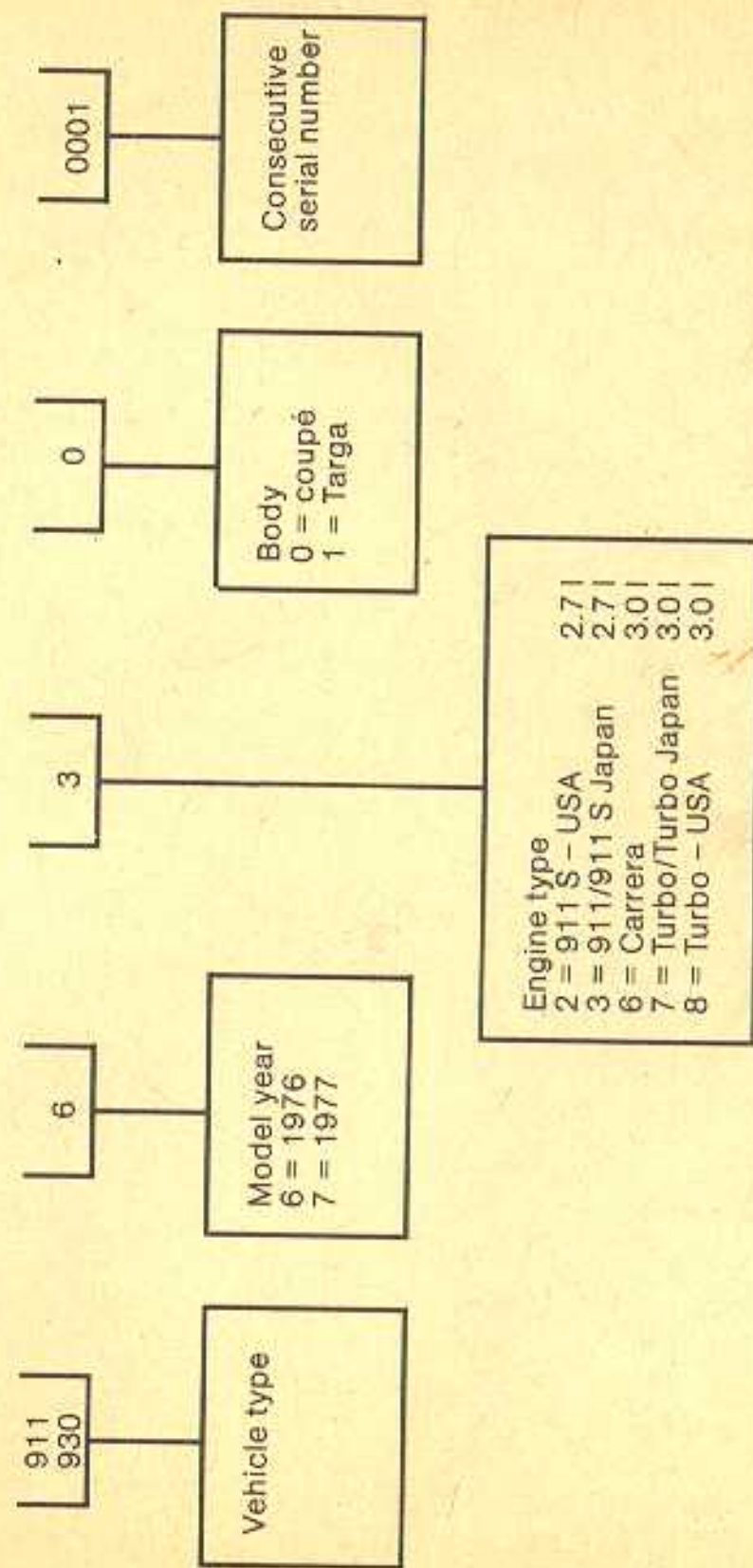

Engine numbers

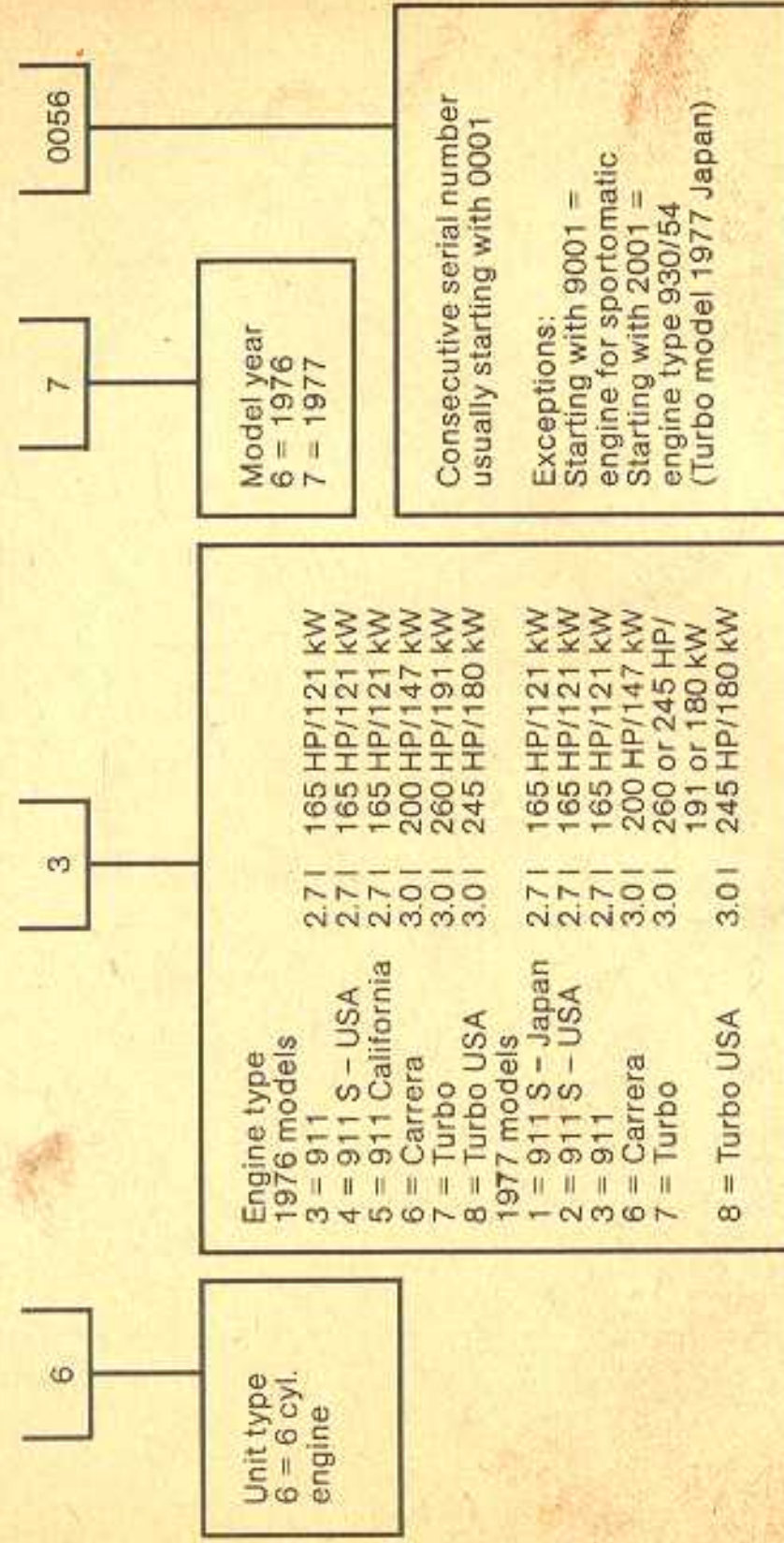

Engine type designations

Year mfd.	Model year	Engine type designation		Displacement	HP/kw		
		Official	Internal				
1975/ 1976	1976	911	911/81	2.7 ltr.	165/121		
		911 Sportomatic	911/86	2.7 ltr.	165/121		
		911 S - USA	911/82	2.7 ltr.	165/121		
		911 S - California	911/84	2.7 ltr.	165/121		
		911 S - USA/ California (Sportomatic)	911/89	2.7 ltr.	165/121		
		Carrera	930/02	3.0 ltr.	200/147		
		Carrera Sportomatic	930/12	3.0 ltr.	200/147		
		Turbo	930/50	3.0 ltr.	260/191		
		Turbo - USA	930/51	3.0 ltr.	245/180		
		1976/ 1977	1977	911	911/81	2.7 ltr.	165/121
				911 Sportomatic	911/86	2.7 ltr.	165/121
911 S - USA	911/85			2.7 ltr.	165/121		
911 S - USA Sportomatic	911/90			2.7 ltr.	165/121		
911 S - Japan	911/94			2.7 ltr.	165/121		
911 S - Japan Sportomatic	911/99			2.7 ltr.	165/121		
Carrera	930/02			3.0 ltr.	200/147		
Carrera Sportomatic	930/12			3.0 ltr.	200/147		
Turbo	930/52			3.0 ltr.	260/191		
Turbo - USA	930/53			3.0 ltr.	245/180		
Turbo - Japan	930/54			3.0 ltr.	245/180		

Transmission numbers

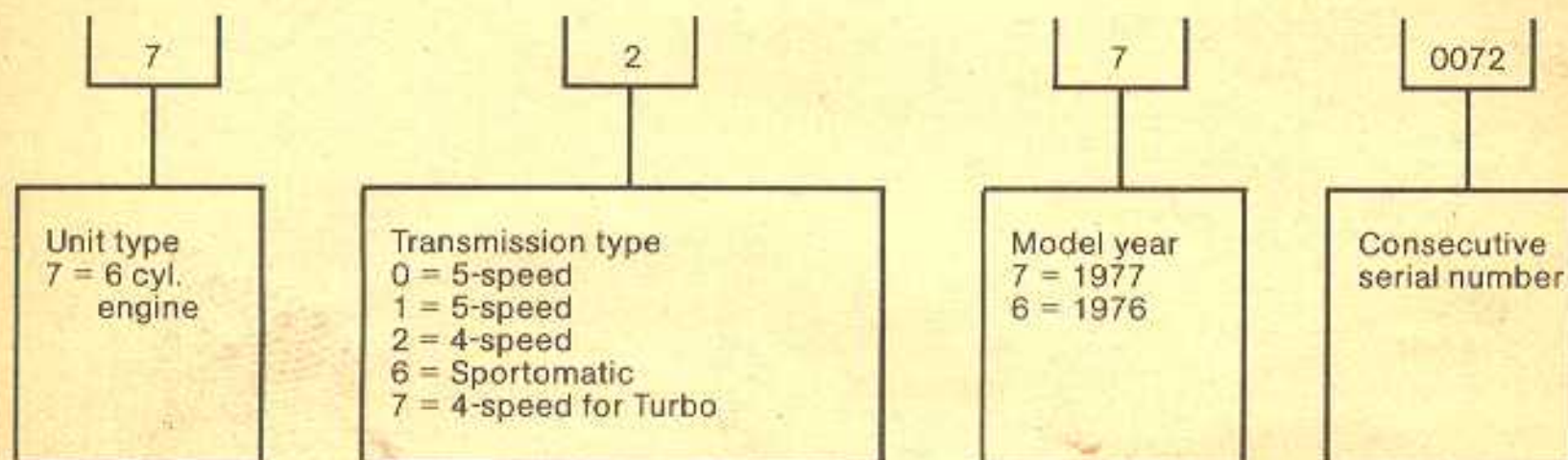

Transmission type codes

Transmission type	Number of gears	1st gear	2nd gear	3rd gear	4th gear	5th gear	Pinion/ring gear	As from chassis number	Remarks
1976 models									
915/44	5	11/35	18/33	23/29	26/26	28/23	8/31	7160001	Manual transm. 911, 911 S - USA, Carrera
915/49	4	11/35	20/32	25/27	28/23		8/31	7260001	Manual transm. 911, Carrera
930/30	4	16/36	23/30	28/25	32/21		9/38	7760001	Manual transm. Turbo
930/32	4	16/36	23/30	28/25	32/21		9/36	7761001	Manual transm. Turbo with 50% tires
925/09	3 SPM	15/36	21/30	27/25			8/27	7662001	Sportomatic 911
925/12	3 SPM	15/36	21/30	27/25			8/27	7660001	Sportomatic 911, 911 S - USA
925/13	3 SPM	15/36	21/30	27/25			8/27	7661001	Sportomatic Carrera
1977 models									
915/60	5	11/35	18/33	23/29	26/26	28/23	8/31	7070001	Manual transm. 911
915/61	5	11/35	18/33	23/29	26/26	28/23	8/31	7170001	Manual transm. 911, 911 S - USA, Carrera
915/65	4	11/35	20/32	25/27	28/23		8/31	7270001	Manual transm. 911
915/66	4	11/35	20/32	25/27	28/23		8/31	7271001	Manual transm. 911, Carrera
925/15	3 SPM	15/36	21/30	27/25			8/27	7670001	Sportomatic 911
925/16	3 SPM	15/36	21/30	27/25			8/27	7671001	Sportomatic Carrera
925/17	3 SPM	15/36	21/30	27/25			8/27	7670501	Sportomatic 911 S - USA
930/33	4	16/36	23/30	28/25	32/21		9/38	7770001	Manual transm. Turbo

Engine specifications for 1976/1977 models

Engine		911	Carrera 3.0	Turbo (Turbo-Carrera USA)
Design		4-stroke internal combustion flat engine (two banks of cylinders opposite each other)		
No. of cylinders		6	same as 911	same as 911
Bore	mm	90	95	95
Stroke	mm	70.4	same as 911	same as 911
Total displacement	cm ³	2687	2993	2993
Compression ratio	ε	8.5 : 1	8.5 : 1	6.5 : 1
Compression pressure	kp/cm ² = bar	max. deviation among each other 1.5, engine temperature at least 60°C		
Max. output (DIN 70020)	HP/kW	165/121	200/147	260/191 (245/180)
At speed	rpm	5800	6000	5500
Max. torque	kpm/Nm	24/235	26/255	35/343
At speed	rpm	4000	4200	4000
Max. liter output	HP/l/kw/l	62/46	68/50	87/64 (82/58)
Mean piston speed at max. output	m/sec	13.6	14.1	12.9
Cut-off speed of speed governor in distributor	rpm	6500 ± 200	6800 ± 200	7000 ± 200

Engine		911	Carrera 3.0	Turbo (Turbo-Carrera USA)
Fuel octane	RON	91	91	96
Cooling system		Air-cooling from axial blower on alternator		
Blower drive		By V-belt off of crankshaft		
Crankshaft/blower ratio		1 : 1.8	1 : 1.8	1 : 1.67
Lubricating system		Dry sump lubrication		
Oil cooling		Oil cooler on crankcase in blower air stream, also cooling coil		
Oil pressure at 80°C	kp/cm ² = bar	5000 rpm ca. 5	same as 911	5500 rpm ca. 4
Oil consumption	l/1000 km	1.5 to 2	1.5 to 2	1 to 2
Crankcase		Pressure cast al/mg alloy 2-piece	Al/si alloy 2-piece	same as Carrera 3.0
Crankshaft		Forged (tenifer treated)	same as 911	same as 911
Crankshaft bearings		8 plain brgs.	same as 911	same as 911
Connecting rods		Forged steel	same as 911	same as 911
Conrod bearings		Half shells	same as 911	same as 911

Engine	911	Carrera 3.0	Turbo (Turbo-Carrera USA)
Piston pin bearing	Press fit bronze bushing	same as 911	same as 911
Intermediate shaft bearings	Two plain bearings	same as 911	same as 911
Pistons	Cast aluminium	Cast aluminium	Forged aluminium
Piston pin	Floating installation, held by circlips		
Piston rings	2 compression rings, 1 oil scraper ring		
Cylinders	Alusil or nikasil cyl.	Nikasil cylinder	Nikasil cylinder
Cylinder head	Single alloy cyl. head	same as 911	same as 911
Valve seat insert	Shrink fit made of alloy gray cast iron	Shrink fit made of annealed sintered steel	same as Carrera 3.0
Valve guide	Thermohedul E or Thermohedul FS	same as 911	same as 911
Valve arrangement for each cylinder	1 intake and 1 exhaust valve in vee suspension		
Exhaust valve	Sodium filled with reinforced seat surface	As Turbo, but without sodium filling	Sodium filled with reinforced seat surface
Valve springs	2 coil springs per valve	same as 911	same as 911

Engine	911	Carrera 3.0	Turbo (Turbo-Carrera USA)
Valve timing	Left and right one each overhead camshaft		
Camshaft	Cast, 3 plain bearings direct in camshaft housing	Cast, 4 plain bearings	same as Carrera 3.0
Camshaft drive	By chain	same as 911	same as 911
Valve clearance on cold engine			
Intake	0.10 mm	same as 911	same as 911
Exhaust	measured betw. valve and rocker arm		
Clutch	Single plate dry type	same as 911	same as 911
Diameter (manual transmission)	mm	225	240
Contact pressure	(kp) N	(795-866) 7800-8495	(920-1020) 9025-10006
Diameter (sportomatic)	mm	190	-
Contact pressure	(kp) N	(800-880) 8000-8800	-
Fuel supply	K-Jetronic	same as 911	same as 911
Fuel pump(s)	1 electric roller cell pump	same as 911	2 electric roller cell pumps

Engine		911	Carrera 3.0	Turbo (Turbo-Carrera USA)
Electrical system				
Battery voltage	V	12	same as 911	same as 911
Battery capacity	Ah	66	same as 911	same as 911
Alternator/output	A/W	70/980	same as 911	same as 911
Regulator switch		Matched to alternator, black plastic housing		
Ignition		CDI contact controlled	same as 911	CDI without contacts
Ignition transformer		Bosch	same as 911	same as 911
Firing order		1-6-2-4-3-5	same as 911	same as 911

Designation of cylinders on 6 cylinder engine

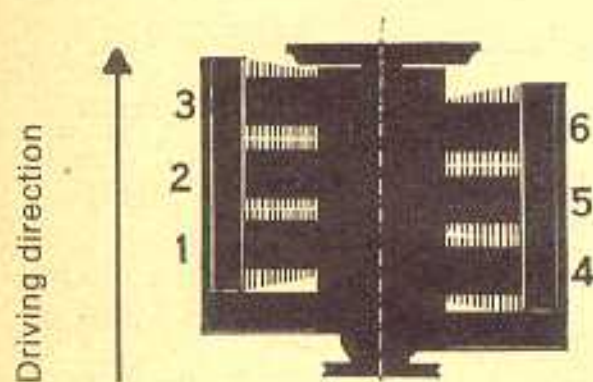

Firing order
1 - 6 - 2 - 4 - 3 - 5

Engine tolerance and wear limit survey

Note: B = bore

W = shaft

Measuring point	Installation size with tolerances mm	Clearance press fit from	(+) or (-) to	Wear limits in mm
Crankshaft - main bearing Bearings 1-7 (d 1)	B 57.020-57.059 W 56.971-56.990	+ 0.010	+ 0.072	visual inspection 56.960
Crankshaft - main bearing Bearing 8 (d 3)	B 31.041-31.084 W 30.980-30.993	+ 0.048	+ 0.104	visual inspection 30.970
Crankpin - conrod bearing (d 2)	B 52.020-52.059 W 51.971-51.990	+ 0.030	+ 0.088	visual inspection 51.960
Crankshaft runout (measured on bearings 4 and 8 with bearings 1 and 7 in vee blocks)				max. 0.04
Crankshaft unbalance				max. 10 cmg
Crankshaft - main bearing Axial play		+ 0.110	+ 0.195	0.30
Crankshaft - timing gear	B 41.975-42.000 W 42.002-42.013	- 0.002	- 0.038	
Crankshaft - distributor drive	B 41.975-42.000 W 42.002-42.013	- 0.002	- 0.038	
Crankshaft - flywheel	B 65.000-65.030 W 64.981-65.000	0.0	+ 0.049	
Crankshaft - pulley	B 30.000-30.033 W 29.960-29.993	+ 0.007	+ 0.073	
Pulley: radial runout				max. 0.15
lateral runout				max. 0.20

Crankshaft - standard and repair sizes

Size	Crankcase dia. brgs. 1-8	All main bearings d 1	Connecting rod bearings d 2	Main brg. dia. d 3 of crankshaft brg. 8	Collar dia. d 4	Seat for timing gear dia. d 5	Crankshaft pulley dia. d 6	Thrust bearing width A
Standard	62.000-62.019	56.990-56.971	51.990-51.971	30.993-30.980	65.000-64.981	42.013-42.002	29.993-29.960	28.000-28.060
- 0.25	62.269-62.250	56.740-56.721	51.740-51.721	30.743-30.730				
- 0.50	Standard	56.490-56.471	51.490-51.471	30.493-30.480	64.500-64.310		29.500-29.370	
- 0.75	Oversize	56.240-56.221	51.240-51.221	30.243-30.230				

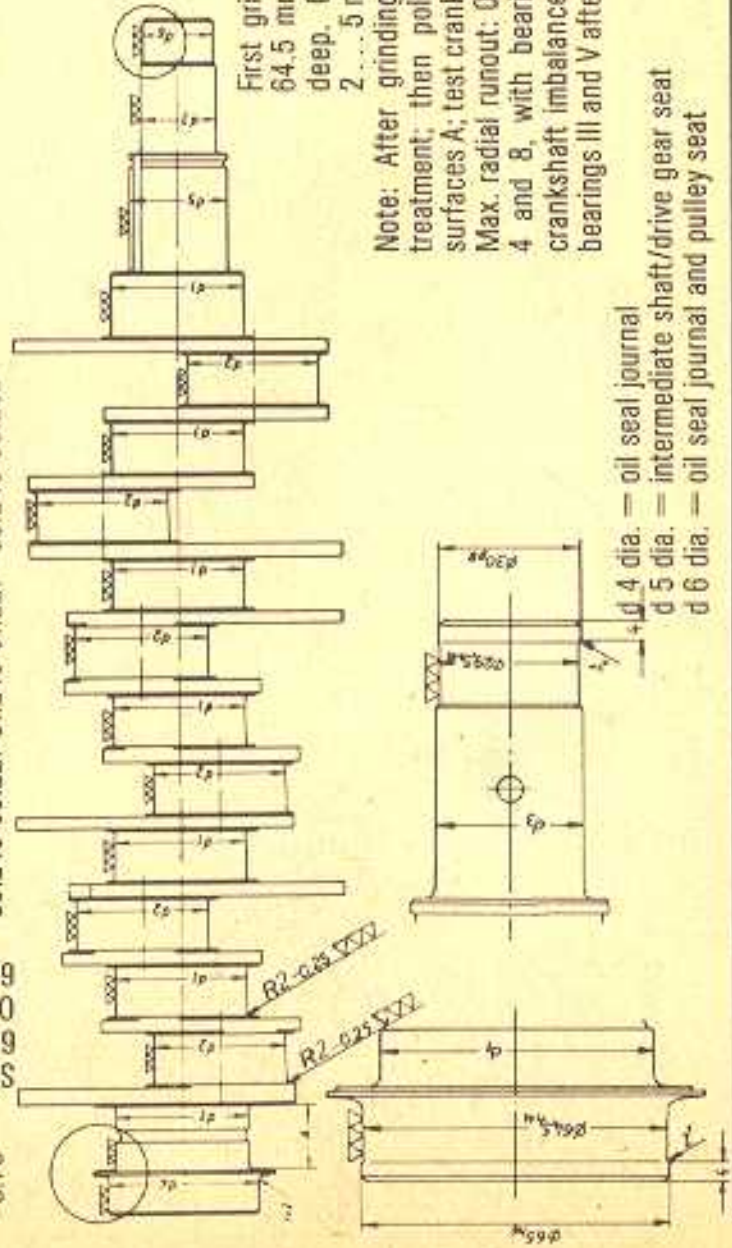

First grind oil seal journals to 29.5 and 64.5 mm as specified, if scoring is too deep. Otherwise repolish as required: 2...5 microns.

Note: After grinding, subject crankshaft to tenifer treatment; then polish bearing journals and thrust surfaces A; test crankshaft for cracks. Max. radial runout: 0.04 mm as measured on bearings 4 and 8, with bearings 1 and 7 on V-blocks. Max. crankshaft imbalance: 10 cmg. Never straighten main bearings III and V after tenifer treatment.

d 4 dia. = oil seal journal
d 5 dia. = intermediate shaft/drive gear seat
d 6 dia. = oil seal journal and pulley seat

Measuring point	Installation size with tolerances mm	Clearance (+) or press fit (-) from to	Wear limit mm
-----------------	--------------------------------------	--	---------------

Crankcase

Case bore for main bearings:			
Bearings 1 - 8	62.000-62.019		
Oversize	62.250-62.269		
Case bor for intermediate shaft:			
Bearing 1 (thrust bearing)	27.500-27.521		
Bearing 2	26.500-26.521		
Spring for pressure relief and safety valve:			
Relaxed length	70.00		
Spring force at 52 mm	10.6 kp		
Spring force at 46 mm	14.1 kp		
Spring wire dia.	1.8		
Block length	33.3		

Connecting rods

A Distance betw. centers	127.80		
b Width of conrod bush	26.00-25.98		
c Width at big end	23.80-23.70		
Width at crankpin	24.00-24.10	+ 0.200	+ 0.400
D Conrod dia. (w/o bearing shell)	56.000-56.019		
E Small end dia.	25.000-25.021		
f Conrod bush removed	25.035-25.055		
Press fit of conrod bush in conrod		- 0.014	- 0.055
G Conrod bush dia. installed in conrod (finished)	22.020-22.033		
Piston pin bushing/piston pin clearance		+ 0.020	+ 0.039 0.055

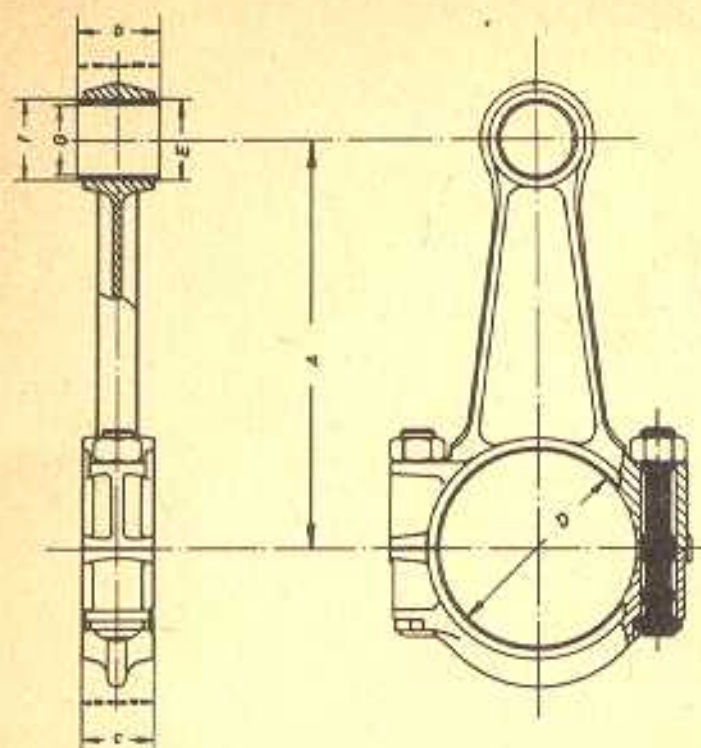

Connecting rod weight groups

Connecting rods are grouped according to weights.

Final digits of the part number indicate the specified weight group.

These final digits are stamped on the connecting rod shank if it is supplied as a replacement part.

Weight Over grams	Weight Under grams	Weight group for service	Service Conrod part number	Conrod code
645	654	1	911.103.015.31	31
654	663	2	911.103.015.32	32
663	672	3	911.103.015.33	33
672	681	4	911.103.015.34	34
681	690	5	911.103.015.35	35
690	699	6	911.103.015.36	36
699	708	7	911.103.015.37	37
708	717	8	911.103.015.38	38
718	727	9	911.103.015.39	39

Note

Connecting rods installed in a given engine must not differ in weight by more than 9 grams. To determine weight group, weigh the complete connecting rod without bearing shells.

Matching intermediate shaft and crankcase

See marking on left half of crankcase below alternator support: 0 or 1.

Distance between centers mm	Crankcase mark	Crankshaft gear marking	Intermediate shaft gear marking	Backlash mm
103.975-103.990	0	0	0	0.029-0.049
		Installation	still possible	
		1	0	0.016-0.042
103.990-104.000	1	0	1	0.017-0.043
		1	1	0.012-0.041
		Installation	still possible	
104.000	1	0	1	0.025-0.049
		1	0	0.025-0.048

Checking intermediate shaft gear

Use 4.5 mm dia. steel rollers to measure gear (see sketch).

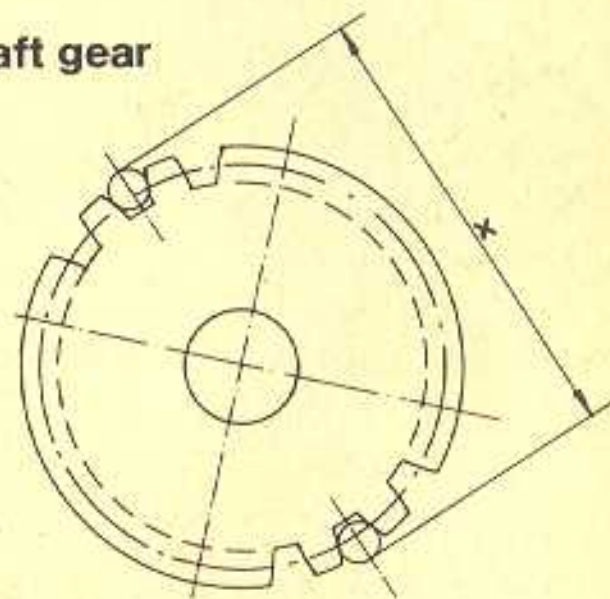

Intermediate shaft gear (standard) - wear limit
Intermediate shaft gear (marked 1) - wear limit

x 136.5 mm
= 136.55 mm

Replace intermediate shaft gears and crankshaft gears in sets only.

Measuring point	Installation size with tolerances mm	Clearance press fit from	(+) or (-) to	Wear limits mm
Intermediate shaft				
Bearing 1 Crankcase bore - shaft	B 27.500-27.521 W 25.000-24.980	.		
Bearing 2 Crankcase bore - shaft	B 26.500-26.521 W 23.980-23.967			
Intermediate shaft clearance		+ 0.030	+ 0.084	
Intermediate shaft axial play		+ 0.040	+ 0.133	0.16
Chain guide - bolt	B 8.000- 8.015 W 7.822- 7.837			
Pinion - distributor shaft	B 12.456-12.474 W 12.444-12.455	+ 0.001	+ 0.030	
Distributor - crankcase	B 27.000-27.021 W 26.947-26.980	+ 0.020	+ 0.074	
Flywheel - drive shaft steel bushing	B 25.000-25.021 W 25.022-25.035	- 0.001	- 0.035	
Flywheel				
Lateral runout				max. 0.10
Radial runout				max. 0.20

Measuring point	Installation size with tolerances mm	Clearance press fit from	(+) or (-) to	Wear limits mm
Timing chain case				
Sprocket pivot shaft - chain tensioner housing	B 15.000-15.018 W 14.973-14.984	+ 0.016	+ 0.045	Visual inspection
Sprocket pivot shaft - sprocket carrier	B 15.000-15.018 W 14.973-14.984	+ 0.016	+ 0.045	
Sprocket carrier - sprocket pin	B 15.000-15.018 W 14.989-15.000	0.000	+ 0.029	
Sprocket - sprocket pin	B 15.032-15.050 W 14.989-15.000	+ 0.032	+ 0.610	Visual inspection
Pin - chain guide	B 8.000- 8.015 W 7.886- 7.895	+ 0.105	+ 0.129	
Pin - timing chain case	B 7.857- 7.872 W 7.886- 7.895	- 0.014	- 0.038	

Parallel alignment of both sprockets may not deviate by more than 0.25 mm.

Measuring point	Installation size with tolerances mm	Clearance press fit from	(+) or (-) to	Wear limits mm
Camshaft housing – camshaft				
Camshaft bearings	B 46.967–46.992 (48.967–48.992)	+ 0.025	+ 0.066	0.010
Camshaft	W 46.926–46.942 (48.926–48.942)			
Camshaft – axial play		+ 0.150	+ 0.200	0.40
Camshaft – timing gear flange	B 30.000–30.013 W 29.979–30.000	0.000	+ 0.034	
Camshaft – runout, measured on center bearing (between points)				max. 0.02
Rocker arm shaft – camshaft case	B 18.000–18.018 W 17.992–18.000	Rocker arm shaft held firm by wedge effect		
Rocker arm – rocker arm shaft	B 18.016–18.027 W 17.992–18.000	+ 0.016	+ 0.035	0.080
Axial play		+ 0.100	+ 0.350	0.50

(values in brackets only for Turbo and Carrera 3.0)

Checking parallel alignment of timing chain sprockets

Before measuring, push intermediate shaft and camshaft axially toward flywheel to set bearing thrust flanges in position.

Measurement is made through hole below intermediate shaft against side of forward chain sprocket on intermediate shaft (dimension A).

This dimension must also be achieved at sprocket for cylinders 4 – 6. Use shims if necessary (maximum permissible difference is 0.25 mm).

Sprocket for cylinders 1 – 3, mounted on intermediate shaft, is positioned 54.8 mm further to front. This 54.8 mm (design dimension) must be considered when determining dimension A. (maximum permissible difference is 0.25 mm).

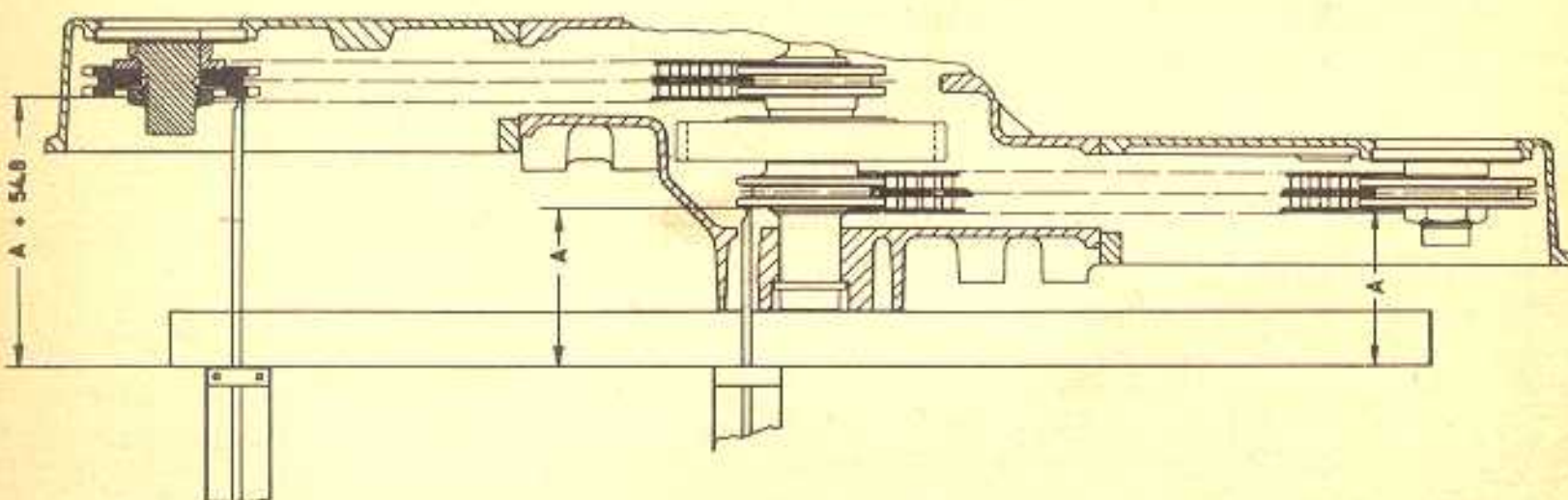

Example: measured dimension A = 78.7 mm
This means sprocket of cylinders 1 – 3 is $A + 54.8 = 78.7 + 54.8 = 133.5$ mm

Pistons and cylinders (sizes, weights and marks)

				911	Carrera 3.0	Turbo
Size	Code	Nominal dia.	Piston dia. D	Piston LS dia. D	Piston dia. D	Piston dia. D
Standard	0	90/95	89.965-89.975	89.952-89.967	94.963-94.977	94.933-94.947
	1		89.975-89.985	89.962-89.977	94.970-94.984	94.943-94.957
	2		89.985-89.995	89.972-89.987	94.977-94.991	94.953-94.967
	3		-	-	94.984-94.998	-
			Nikasil cylinder dia.	Alusil cylinder dia.	Nikasil cylinder dia.	Nikasil cylinder dia.
Standard	0	90/95	90.000-90.010	90.000-90.010	95.000-95.007	95.000-95.010
	1		90.010-90.020	90.010-90.020	95.007-95.014	95.010-95.020
	2		90.020-90.030	90.020-90.030	95.014-95.021	95.020-95.030
	3		-	-	95.021-95.028	-
Play between piston and cylinder			0.025-0.045	0.035-0.060	0.023-0.044	0.053-0.077
Piston weight			Max. difference in weight of pistons of one set: 6 g.			

Cylinder sizes

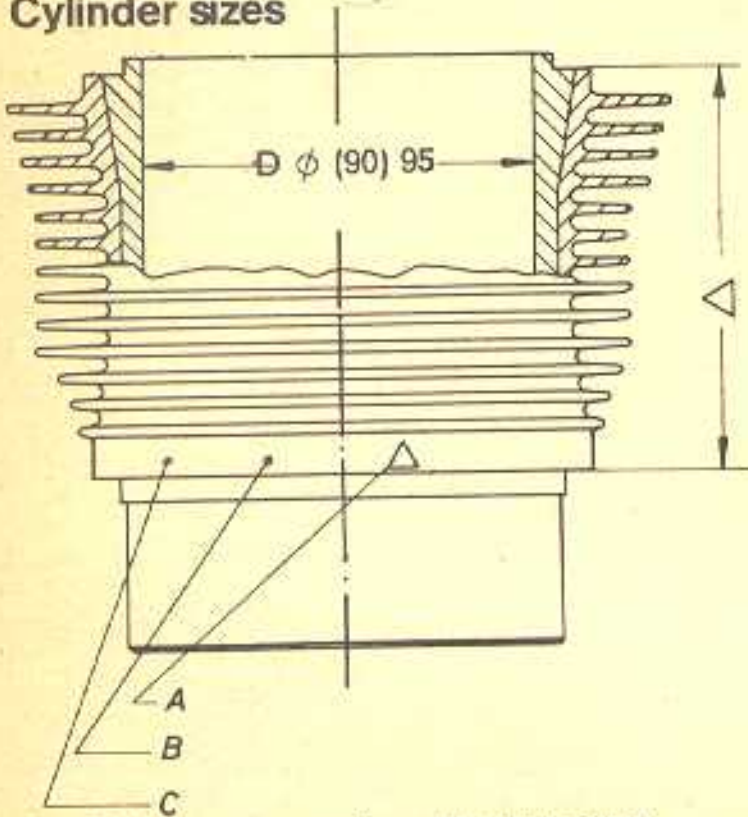

- A Tolerance group for cylinder height
- B Tolerance group for cylinder diameter (refer to table)
- C Manufacturer's identification

Cylinder height tolerances

Code A	Cylinder height
5	85.400-85.425
6	85.425-85.450

Checking pistons and cylinders

Cylinders

D1 = Measuring point for wear and ovality

30 mm below cylinder upper edge

The cylinder is worn, if the distance at this measuring point is 0.08 mm more than the installation size. The ovality of a cylinder is determined by measuring in directions a and b. The difference between a and b must not exceed 0.04 mm.

D2 = Measuring point for piston pin gap

Rings slid in at height of cylinder base gasket.

Pistons

D = Measuring point for wear

At height of piston pin bore lower edge.

Note

Replace pistons and cylinders when running clearance exceeds 0.15 mm. This results from the difference between the max. cylinder dia. and the min. piston dia.

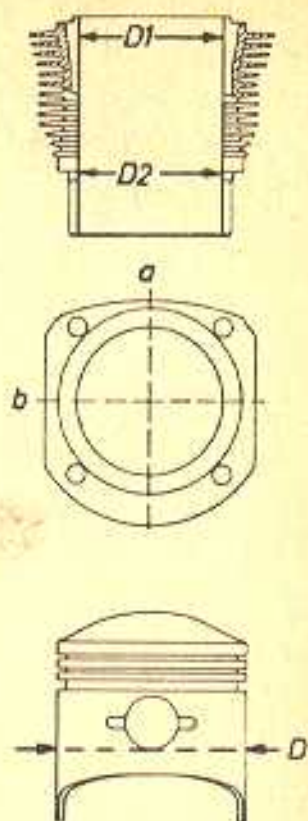

Piston ring gap

Piston ring	Gap mm (installation size)	Gap mm (wear limit)
M ring, I and II	0.1 - 0.2	0.8
Oil scraper ring, III	0.15 - 0.3	1.0
Oil scraper ring, III		
3-piece „LS“ ring (see measuring point „D2“)	0.4 - 1.4	2.0

Piston ring height clearance

Piston ring	Height play mm (installation size)	Height play mm (wear limit)
M ring, I	0.070 - 0.102	0.2
M ring, II	0.040 - 0.072	0.2
Oil scraper ring, III	0.020 - 0.052	0.1

911

Intake

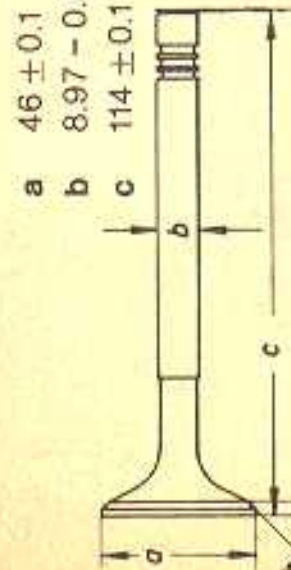

Checking valve seats

To check valve seat depth, insert respective valve into guide and measure distance between valve stem end and bottom of shim cavity, without shims (see distance A in sketch).

If dimension is greater than specified, measure again a new valve. If dimension is still beyond specifications, valve seat inserts have been cut too deep and should be replaced, or exchange cylinder head.

Valve size

Carrera 3.0

Intake

49 ± 0.1

49 ± 0.1

41.5 ± 0.1

8.95 - 0.012

8.95 - 0.012

110.1 ± 0.25

110.1 ± 0.25

108.4 ± 0.25

108.4 ± 0.25

Turbo

Intake

49 ± 0.1

49 ± 0.1

41.5 ± 0.1

8.95 - 0.012

8.95 - 0.012

110.1 ± 0.25

110.1 ± 0.25

108.4 ± 0.25

108.4 ± 0.25

Exhaust

40 ± 0.1

40 ± 0.1

8.95 - 0.012

8.95 - 0.012

113.5 ± 0.1

113.5 ± 0.1

110.1 ± 0.25

110.1 ± 0.25

108.4 ± 0.25

108.4 ± 0.25

Turbo

Intake

49 ± 0.1

49 ± 0.1

41.5 ± 0.1

8.95 - 0.012

8.95 - 0.012

110.1 ± 0.25

110.1 ± 0.25

108.4 ± 0.25

108.4 ± 0.25

Exhaust

40 ± 0.1

40 ± 0.1

8.95 - 0.012

8.95 - 0.012

113.5 ± 0.1

113.5 ± 0.1

110.1 ± 0.25

110.1 ± 0.25

108.4 ± 0.25

108.4 ± 0.25

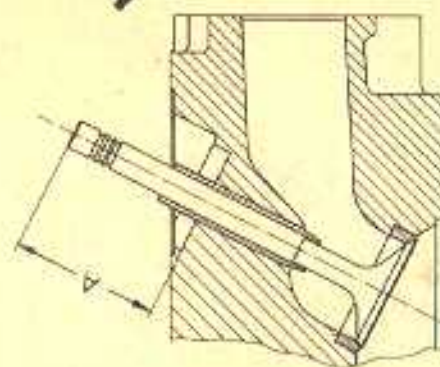

Distance A

911

47.50 ± 0.6 mm

Carrera 3.0, Turbo

46.00 ± 0.3 mm

Valve guides (wear limits, installation sizes)

Measuring point	Installation size with tolerances mm	Clearance (+) or press fit (-)		Wear limits mm
		from	to	
Valve guide, outside dia. d2	13.049-13.060	-0.031	-0.060	
Cylinder head, bore dia. D2	13.000-13.018			
Intake valve guide, inside dia. g	9.000- 9.015	+ 0.030	+ 0.057	0.15
Intake valve stem, dia. b	8.958- 8.970			
Exhaust valve guide, inside dia. g	9.000- 9.015	+ 0.050	+ 0.077	0.20
Exhaust valve stem, dia. b	8.938- 8.950			

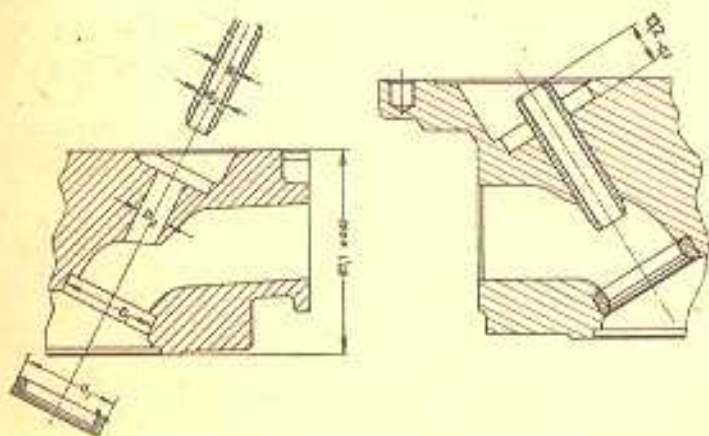

Machine 1st and 2nd oversize to correspond with bore in cylinder head.
Press fit: 0.06-0.09 mm.

Specifications for installation of valve seat inserts

		911		Turbo, Carrera 3.0	
		Outside dia. d1 valve seat insert	Bore D1 in cylinder head	Outside dia. d1 valve seat insert	Bore D1 in cylinder head
Standard size	Intake	48.180-48.164	48.000-48.025	51.680-51.661	51.500-51.530
Standard size	Exhaust	42.200-42.184	42.000-42.025	44.200-44.184	44.000-44.025
1st oversize	Intake	48.500-48.484	48.320-48.345	52.000-51.981	51.820-51.850
1st oversize	Exhaust	42.760-42.744	42.560-42.585	44.760-44.744	44.560-44.585

Angles and sizes of valve seat inserts

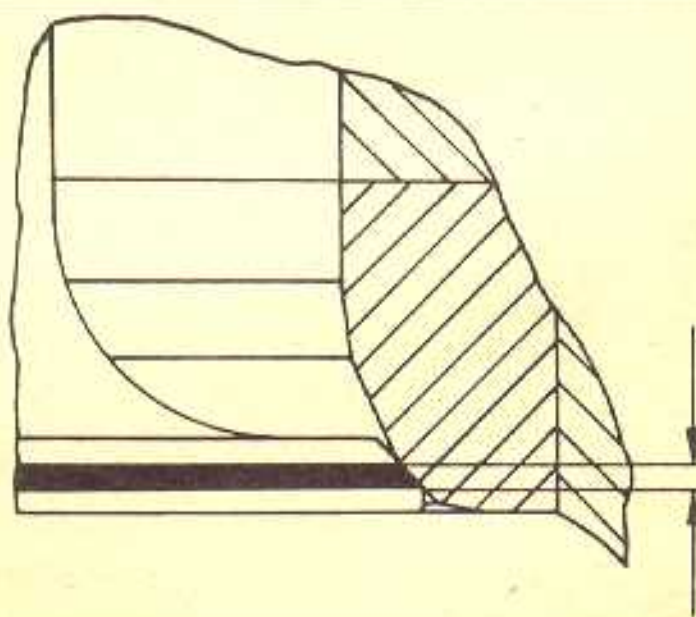
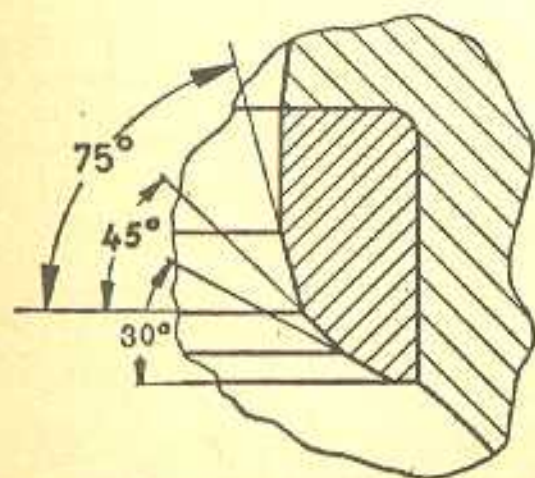

Intake = 1.5 ± 0.1
Exhaust = 1.5 ± 0.1

Installation lengths of valve springs

Check distance A with Special Tool P 10 C and, if necessary, correct by adding or removing shims.

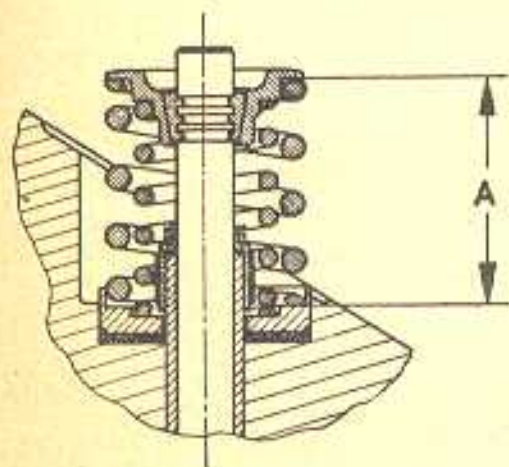

	Intake	Exhaust
911	35.0 ± 0.3 mm	35.5 ± 0.3 mm
Carrera	34.5 ± 0.3 mm	34.5 ± 0.3 mm
Turbo	33.5 ± 0.3 mm	33.5 ± 0.3 mm

Camshafts, timing

	Type	Camshaft left Part No.	Camshaft right Part No.
911 engine	911/81	911.105.143.00	911.105.144.00
	911/82		
	911/84		
	911/86		
	911/89		
Carrera engine	911/85	930.105.147.08	930.105.148.08
	930/02		
	930/12		
Turbo engine	930/50	930.105.141.00	930.105.142.00
	930/51		
	930/52	930.105.143.00	
	930/53		
	930/54		

Clutch drive plate

Measuring point, type	Installation size with tolerances mm
911, Carrera	
Clutch drive plate	
Relaxed thickness (new)	8.1 ± 0.3
Max. lateral runout	0.6
Turbo	
Relaxed thickness (new)	10.1 ± 0.3
Max. lateral runout	0.5
Sportomatic	
Relaxed thickness (new)	7.3 ± 0.25
Max. lateral runout	0.5

Identification on face of camshaft		Intake valve stroke in over- lapping TDC with 0.1 mm valve clearance	Timing with 0.1 mm valve clearance
Left	Right		
911.143.00	911.144.00	0.4 - 0.54	Intake opens 6° ATDC Intake closes 50° ABDC Exhaust opens 24° BBDC Exhaust closes 2° ATDC
930.147.08	930.148.08	0.9 - 1.1	Intake opens 1° BTDC Intake closes 53° ABDC Exhaust opens 43° BBDC Exhaust closes 3° ATDC
930.141.00 930.143.00	930.142.00	0.65 - 0.8	Intake opens 3° ATDC Intake closes 37° ABDC Exhaust opens 29° BBDC Exhaust closes 3° BTDC

**Wear limits
mm**6.3 for symmetrical wear
max. 0.68.5 for symmetrical wear
max. 0.55.5
for symmetrical wear
max. 0.5

Machining flywheel

The flywheel bearing surface on the drive plate can be machined on a lathe, if there is serious scoring or considerable burnt spots.

Keep lathe cut as small as possible.

Wear limit of flywheel thickness is 8.5 mm.

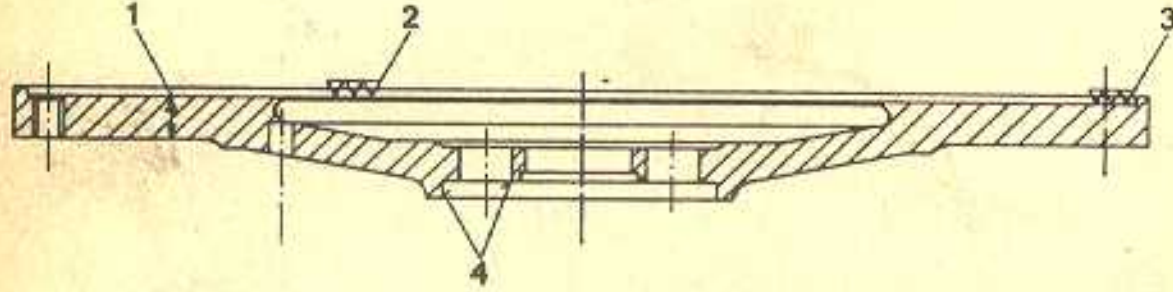

- | | | | |
|---|-----------------------|---|-----------------------|
| 1 | Wear limit 8.5 mm* | 3 | Max. runout 0.1 mm |
| 2 | Smallest possible cut | 4 | Lathe mounting points |

* Turbo: wear limit of 9.9 mm.

Important engine adjusting data

Engine, type	911 76/77 models	Carrera 76/77 models	Turbo 76/77 models	911 S (USA) 1977 models	911 S (Calif.) 1977 models
Ignition timing ** at engine speed (rpm) Vacuum hose detached?	5° ATDC 900 no	5° ATDC 900 no	29 + 2° BTDC 4000 yes TDC ± 4° 900 - 950 no	TDC ± 2° 950 - 1000 no	15 ± 2° ATDC 1000 no
Ignition timing control at engine speed (rpm) Vacuum hose detached?	900 ± 50 1.0 - 1.5	900 ± 50 1.0 - 1.5	900 ± 50 2.0 - 4.0* (2 - 2.5 for 1976 models)	900 - 1000* 1.5 - 3.0*	950 - 1050* 1.5 - 3.0*
Charge pressure (bar) at engine speed (rpm)	- -	- -	0.80 - 0.87 4000	- -	- -
System pressure (bar)	4.5 - 5.2	4.5 - 5.2	6.0 - 6.7	4.5 - 5.2	4.5 - 5.2
Control pressure (bar) (warm-up regulator off) at idle speed/throttle valve closed With engine stopped - fuel pump running	3.6 ± 0.15 2.9 ± 0.15	3.6 ± 0.15 2.9 ± 0.15	3.6 ± 0.15 2.9 ± 0.15	3.6 ± 0.15 2.9 ± 0.15	3.6 ± 0.15 2.9 ± 0.15
Valve clearance, intake (mm) exhaust (mm)	0.10 0.10	0.10 0.10	0.10 0.10	0.10 0.10	0.10 0.10
Timing adjustment (mm)	0.40 - 0.54	0.90 - 1.10	0.65 - 0.80	0.40 - 0.54	0.40 - 0.54

*Detach hose at auxiliary air pump and plug, if CO level has to be checked or adjusted.

** At 80° C oil temperature.

Important engine adjusting data

Engine, type	911 S (Japan) 1977 models	Turbo (USA) 1977 models	Turbo (Japan) 1977 models	Turbo (USA) 1976 models	911 S (USA) 1976 models
Ignition timing** at engine speed (rpm)	15 ± 2° ATDC 950 - 1000	7 ± 2° ATDC 950 - 1050	15 ± 2° ATDC 950 - 1050	5 ± 3° ATDC 900 - 1000	5° ATDC 900
Vacuum hose detached?	no	no	no	no	no
Ignition timing control at engine speed (rpm)	-	29 ± 3° BTDC 4000	30 ± 3° BTDC 4000	26 ± 3° BTDC 4000	-
Vacuum hose detached?	-	yes	yes	yes	-
Idle speed (rpm)	950 - 1050*	950 - 1050*	950 - 1050*	900 + 50	900 ± 50
CO level (%) (at idle speed)	1.0 - 2.0*	2.0 - 4.0*	1.0 - 1.5*	1.0 - 3.0*	2.0 - 4.0*
Charge pressure (bar) at engine speed (rpm)	-	0.80 - 0.87 4000	0.80 - 0.87 4000	0.80 - 0.87 4000	-
System pressure (bar)	4.5 - 5.2	6.0 - 6.7	6.0 - 6.7	6.0 - 6.7	4.5 - 5.2
Control pressure (bar) (warm-up regulator off) at idle speed/throttle valve closed	3.6 ± 0.15	3.6 ± 0.15	3.6 ± 0.15	3.6 ± 0.15	3.6 ± 0.15
With engine stopped - fuel pump running	2.9 ± 0.15	2.9 ± 0.15	2.9 ± 0.15	2.9 ± 0.15	2.9 ± 0.15
Valve clearance, intake (mm)	0.10	0.10	0.10	0.10	0.10
exhaust (mm)	0.10	0.10	0.10	0.10	0.10
Timing adjustment (mm)	0.40 - 0.54	0.65 - 0.80	0.65 - 0.80	0.65 - 0.80	0.40 - 0.54

*Detach hose at auxiliary air pump and plug, if CO level has to be checked or adjusted.

**At 80° C oil temperature.

		911	Carrera	Turbo
Dwell angle	Bosch	38 ± 3°/0.35 mm	same as 911	-
	Marelli	37 ± 3°/0.35 mm		
Spark plugs (electrode gap)	Bosch	W 225 T 30 (0.7 mm)	W 260 T 2 (0.7 mm)	W 280 P 21 (0.6 mm)
	Beru	225/14/3 (0.7 mm)	260/14/3 (0.7 mm)	

Battery charge condition	Normal climate zone		Tropics
	Density	Freezing point	Density
Dead	1.12	- 11° C	1.08
Half charged	1.20	- 27° C	1.16
Charged	1.28	- 68° C	1.23

Tightening torque for engine

Location	Threads	Torque kpm	Nm
Crankcase bolts	M 10	3.5	35
All bolts on crankcase and camshaft housing	M 8	2.5	25
Flywheel mountings	M 12 x 1.5	15	150
Pulley to crankshaft	M 12 x 1.5	8	80
Double-belt pulley to crankshaft (air conditioner)	M 12 x 1.5	15	150
Connecting rod bolts	M 10 x 1.25	5 - 5.5	50 - 55
Cylinder head nuts	M 10 socket 3	3 - 3.3	30 - 33
Nuts con camshaft	M 27 x 2	14	140
Rocker arm shafts	M 6 socket	1.8	18
Wide clamp on blower housing	M 8	0.8	8
Pulley to alternator	M 16 x 1	4	40
Spark plugs	M 14 x 1.25	2.5 - 3	25 - 30
Adaptor on cylinder head (air injection)	M 10 x 1	1.0 - 1.2	10 - 12
Air line (coupling) to adaptor	M 14 x 1.5	2.2 - 2.4	22 - 24
Reactor to cylinder head	M 8	2.0 - 2.3	20 - 23

Warm-up regulator, fuel injectors (continuous fuel injection system)

Test phase

Testing and adjusting data
911, Carrera, 911 S - USA

Turbo

Control pressure cold
(corresponding with
outside temperature)

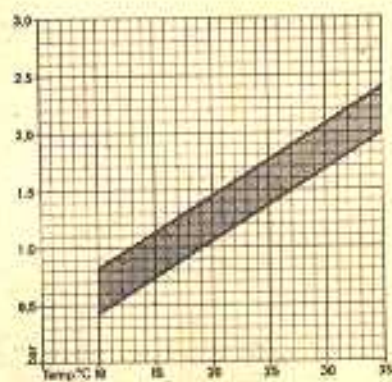
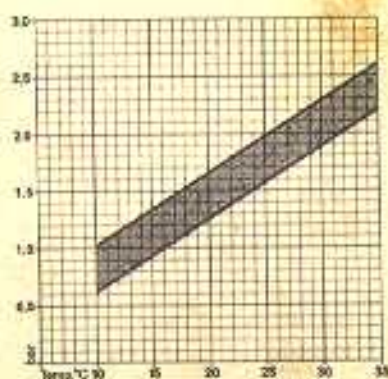

Fuel injectors: opening pressure

2.5 to 3.6 bar

2.0 to 3.2 bar

Adjustment of drive pinion

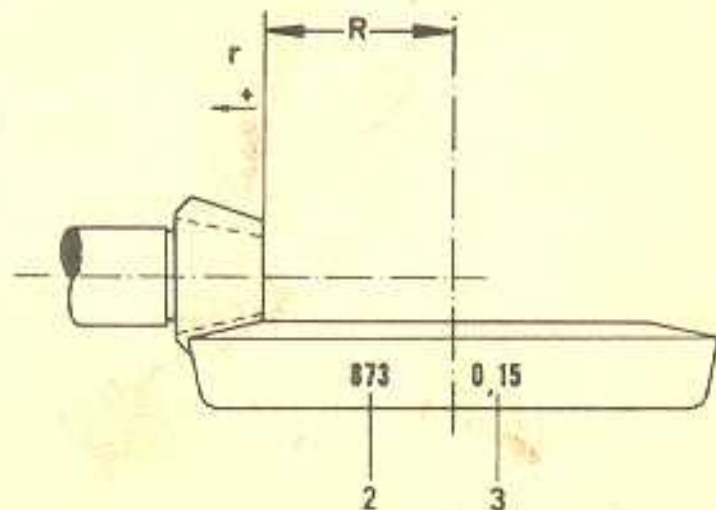
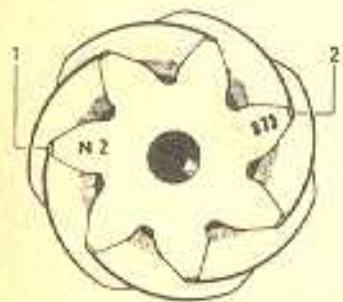

R = Design dimension

911, Carrera = 66.30 mm

Turbo = 81.69 mm (82.29 transm. type 930/30 and 930/33)

Sportomatic = 59.70 mm

r = Deviation from R given in + 1/100 mm (N 2 = + 0.02 mm)

1 = Deviation r

2 = Matching number

3 = Backlash

Adjustment of ring gear

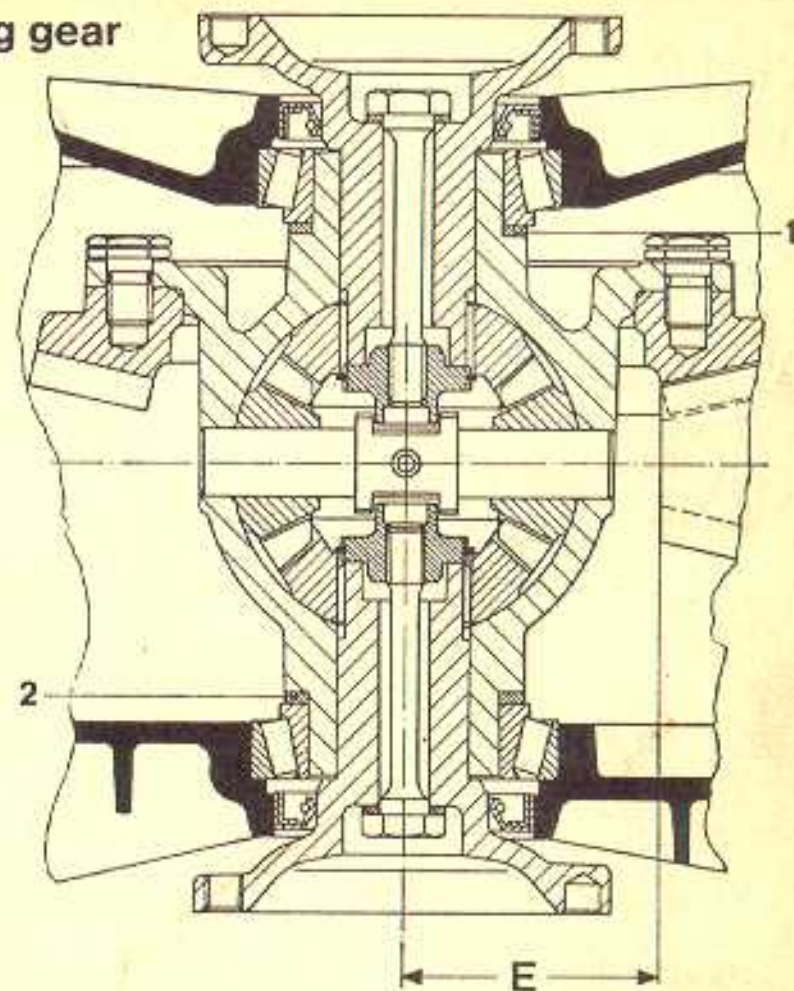

The backlash between the ring gear and pinion can only be adjusted by changing the thickness of spacers and must be from 0.12 to 0.18 mm (measured at 4 different points).

Exception: the Turbo is measured at reverse gear III = 0.38 ± 0.1 mm equals 0.20 mm on the ring gear (930/30 = 0.33 ± 0.1 mm equals 0.16 mm).

Care and cleanliness are essential during all assembly operations and measurements to assure accurate results.

Press fit of taper roller bearings for differential in transmission case - for SKF bearings 2.5 - 3.5 Nm (25 - 35 kpcm), for Fag bearings 4.5 - 6.5 Nm (45 - 65 kpcm).

Important manual transmission adjusting data

2 examples for adjustment of pinion and ring gear on type 915 transmissions

	With transmission gauge P 258	With universal gauge VW 385
Design dimension	66.30 mm	66.30 mm
Deviation	+ 0.02 mm	+ 0.10 mm
	<u>66.32 mm</u>	<u>66.40 mm</u>
Dial gauge setting	66.61 mm	66.30 mm
Measured dimension (without shims)	- 0.39	- 0.29 mm
	<u>66.22 mm</u>	<u>66.01 mm</u>
Distance to face end of pinion shaft	66.22 mm	66.01 mm
Adjustment dimension „E”	66.32 mm	66.40 mm
Distance to face end of pinion shaft	- 66.22 mm	- 66.01 mm
	<u>0.10 mm</u>	<u>* 0.39 mm</u>
Thickness of shims	0.10 mm	* 0.39 mm

*) Round off to nearest 0.05 mm.

Shims are available 0.10, 0.15 and 0.20 mm thick.

Recheck adjustment dimension „E” after installation of paper gaskets;
a deviation of ± 0.03 mm is permissible.

Important sportomatic transmission adjusting data

	Transmission type 925	
	With transmission gauge P 258	With universal gauge VW 385
Design dimension	59.70 mm	59.70 mm
Deviation	+ 0.18 mm	+ 0.04 mm
	<u>59.88 mm</u>	<u>59.74 mm</u>
Adjustment dimension „E”	59.88 mm	59.74 mm
Basic dimension (without gasket)	60.70 mm	60.70 mm
Adjustment dimension	- 59.88 mm	- 59.74 mm
	<u>0.82 mm *</u>	<u>0.96 mm *</u>
Thickness of shim	0.82 mm *	0.96 mm *
Measurement after installation of shims:		
Dial gauge setting	60.02 mm	59.70 mm
Measured dimension (without gasket)	- 0.37 mm	- 0.32 mm
	<u>59.65 mm</u>	<u>59.38 mm</u>
Distance to face end of pinion shaft	59.65 mm	59.38 mm
Adjustment dimension „E”	59.88 mm	59.74 mm
Distance to face end of pinion shaft	- 59.65 mm	- 59.38 mm
	<u>0.23 mm *</u>	<u>0.36 mm *</u>
Paper gasket	0.23 mm *	0.36 mm *

*) Round off to nearest 0.05 mm.

Paper gaskets are available 0.1, 0.15 and 0.20 mm thick.

Recheck adjustment dimension „E” after installation of paper gaskets;
a deviation of ± 0.03 mm is permissible.

Transmission tolerance survey

Type

Type 930

Measuring point	Installation tolerance mm	Wear limit mm	Installation tolerance mm	Wear limit mm
1. Backlash between gear I and II				
1st gear	0.05 - 0.13 (0.17)	0.22	0.055 - 0.13	0.22
2nd gear				
3rd gear				
4th gear				
5th gear				
2. Loose gears on pinion and drive shaft				
Axial clearance				
1st gear	0.3 - 0.4	0.5	same as 915	
2nd gear	0.2 - 0.3	0.4		
3rd gear	0.2 - 0.3	0.4		
4th gear	0.2 - 0.3	0.4		
5th gear	0.2 - 0.3	0.4		
3. Selector rods				
a) in guides	0.195 - 0.236	0.4	same as 915	
radial clearance				
b) Runout	-	0.1		

Measuring point	Installation tolerance mm	Wear limit mm	Installation tolerance mm	Wear limit mm
4. Selector forks in operating sleeve				
Axial clearance				
5th and reverse gear	0.1 - 0.3	0.5	same as 915	
1st and 2nd gear				
3rd and 4th gear				
5. Synchronizing rings				
Outside dia. installed				
1st gear	86.20 - 86.54	after	86.15 - 86.65	after
2nd gear	86.20 - 86.54	local wear	86.15 - 86.65	local wear
3rd gear	76.12 - 76.48	through of	76.20 - 76.55	through of
4th gear	76.12 - 76.48	molybdenum	76.20 - 76.55	molybdenum
5th gear	76.12 - 76.48	layer	-	layer
6. Drive shaft			same as 915	
Max. runout at guidepin	0.1	0.1 (align)		

(in brackets: only 1st and 2nd gear of 5-speed transmissions)

Tightening torque for bolts and nuts of manual transmission 915

Location	Designation	Threads	Material	Tightening kpm	torque Nm
Transmission case (oil drain)	Plug with magnet	M 24 taper	St 37	2.0 - 2.5	20-25
Gear box (oil filler)	Plug	M 24 taper	St 37	2.0 - 2.5	20-25
Gear box, side, front cover, shift cover	Mid-grip nut	M 8 x 1.25	X12CrNi 18.8	2.2 - 2.5	22-25
Front cover	Backup light switch	M 18 x 1.5	Ms	3.5 - 4.0	35-40
Drive shaft	Collared nut	M 30 x 1.5	8.8	16.0 - 18.0	160-180
Drive shaft	Castle nut	M 18 x 1.5	6.8	12.0 - 14.0	120-140
Transmission support clamping plate and mountings	Hexagon nut	M 8 x 1.25	8	2.1 - 2.3	21-23
Drive pinion	Collared nut	M 24 x 1.5	8	14.0 - 16.0	140-160
Fork, gearshift	Hexagon nut	M 6 x 1.0	8	0.8 - 0.9	8-9
Shift lock, transmission case	Hexagon head bolt	M 10 x 1.5	8.8	1.5 - 1.8	15 - 18
Transmission case	Vent	M 16 x 1.5	9 S 20 K	2.3 - 3.0	20 - 30
Selector forks	Hexagon head bolt	M 8 x 1.25	8.8	2.4 - 2.6	24 - 26
Ring gear (differential)	Hexagon head bolt	M 12 x 1.25	11.9	11.5 - 12.0	115-120
Ring gear (locking differential)	Hexagon head bolt	M 12 x 1.25	11.9 12.9	14.0 - 15.0 15.0 - 16.0	140-150 150-160
Joint flange	Expansion bolt	M 10 x 1.5	8.8	2.6 - 3.0	26 - 30
Starter mountings	Hexagon nut	M 10 x 1.5	8	4.6 - 4.8	46 - 48
Pressure tube (drive pinion)	Hexagon head bolt M 6 x 35	M 6 x 1.0	8.8	0.8 - 0.9	8 - 9
Front cover	Pressure relief bolt	M 12 x 1.5	9 S 20 K	2.2 - 2.5	22 - 25
Oil pump cover	Mid-grip nut	M 6 x 1.0	X12CrNi 18.8	0.9 - 1.0	9 - 10
Suction tube	Fillister head bolt M 6 x 15	M 6 x 1.0	8.8	0.8 - 0.9	8 - 9
Pressure tube (gear box)	Hexagon head bolt M 6 x 12	M 6 x 1.0	8.8	0.8 - 0.9	8 - 9

Tightening torque for bolts and nuts of manual transmission 930

Location	Designation	Threads	Material	Tightening torque	
				kpm	Nm
Drive shaft	Collared nut	M 30x1.5	8.8	21.0	210
Drive shaft	Collared nut	M 20x1.5	C 35 V	16.0-18.0	160-180
Drive pinion	Collared nut	M 24x1.5	8	19.0-20.0	190-200
Joint flange	Expansion bolt	M 10x1.5	8.8	2.6-3.0	26-30
Transmission case	Vent	M 14x1.5	9 S 20 K	2.0-3.0	20-30
Connecting rod, gearshift	Conical bolt	M 8x1.25	8.8	2.3-2.6	23-26
Shift cover	Mid-grip nut	M 8x1.25	X12CrNi 18.8	2.2-2.5	22-25
Gear box	Backup light switch	M 18x1.5	Ms	2.5-3.5	25-35
Gearshift, fork	Hexagon nut	M 6x1.0	8.8	0.9-1.1	9-11
Clamping plate, gear box and transmission case, front and side transmission covers	Hexagon nut	M 8x1.25	8	2.2-2.5	22-25
Shift lock, transmission case	Hexagon head bolt	M 10x1.5	8.8	1.5-1.8	15-18
Selector forks	Hexagon head bolt	M 8x1.25	8.8	2.4-2.6	24-26
Ring gear (differential)	Hexagon head bolt	M 12x1.25	11.9	13.5-14.0	135-140
Locking differential	Hexagon head bolt	M 12x1.25	12.0	15.0-16.0	150-160

Transmission case (oil drain)	Plug with magnet	M 24 x 1.5 (taper 1:16)	St 37	2.0 - 2.5	20 - 25
Gear box (oil filler)	Plug	M 30x1.5	5.8	2.0 - 2.5	20 - 25
Reverse gear detent	Plug	M 16x1.5	5.8	2.0 - 2.5	20 - 25
Guide tube	Fillister head bolt	M 6x1.0	8.8	0.8 - 1.0	8 - 10
Clutch and gear ring mountings	Fillister head bolt	M 8x1.0	8.8	2.0 - 2.5	10 - 25
Starter mountings	Hexagon nut	M 10x1.5	8	4.6 - 5.0	46 - 50
Holder to shift base	Hexagon head bolt	M 6	8.8	0.6	6
Shift base to tunnel	Fillister head bolt	M 8	8.8	2.1	21
Conical bolt in selector rod head	Conical bolt	M 8	8.8	1.5	15
Conical bolt on shift coupling	Conical bolt	M 8	8.8	1.5	15
Clamp mountings	Hexagon head bolt	M 8	8.8	2.5	25
Transmission cover	Fillister head bolt	M 6	8.8	1.4	14
Locking differential					

Tightening torque for bolts and nuts of sportomatic transmission

Location	Designation	Threads	Material	Tightening torque	
				kpm	Nm
Transmission case (on stud for side and front transmission cover as well as fork)	Hexagon nut	M 8x1.25	6.8	2.1 - 2.3	21 - 23
	Mid-grip nut	M 8x1.25	x12CrNi 18.8	2.2 - 2.5	22 - 25
Transmission case (oil filler)	Plug	M 24x1.5 (taper 1 : 16)	St 37	2.0 - 2.5	20 - 25
Transmission case (oil drain)	Plug with magnet	M 24x1.5 (taper 1 : 16)	St 37	2.0 - 2.5	20 - 25
Transmission case (vent)	Vent	M 14x1.5 (taper 1 : 16)	9 S 20 K	2.0 - 3.0	20 - 30
Transmission case	Backup light switch	M 18x1.5	Ms	3.5 - 4.0	35 - 40
Transmission case	Bridge-over switch	M 18x1.5	Ms	3.5 - 4.0	35 - 40
Transmission case (starter)	Hexagon nut	M 10x1.5	8.8	4.6 - 4.8	46 - 48
Transmission case (power motor support and mountings)	Hexagon nut	M 8x1.25	6.8	2.1 - 2.3	21 - 23
Converter housing to transmission case	Hexagon nut	M 8x1.25	6.8	2.1 - 2.3	21 - 23
	Hexagon nut	M 10x1.5	8.8 (SW15)	4.6 - 4.8	46 - 48
Converter housing (one-way clutch mountings)	Fillister head bolt	M 6x1.0	10.9	1.2 - 1.4	12 - 14

Converter housing	Threaded adaptor	M 24x1.5	6 S	3.0 - 3.5	30 - 35
Converter housing	Temperature transmitter	M 14x1.5	Ms	2.5 - 3.0	25 - 30
Converter housing	Temperature switch	M 14x1.5	Ms	2.5 - 3.0	25 - 30
Converter housing (clutch pressure plate)	Fillister head bolt	M 6x1.0	10.9	1.2 - 1.4	12 - 14
Converter drive plate	12-sided bolt	M 8x1.25	8.8	2.4 - 2.6	24 - 26
Intermediate plate (clamping)	Hexagon head bolt	M 8x1.25	8.8	2.1 - 2.3	21 - 23
Intermediate plate	Reversing lever shaft	M 8x1.25	9 S 20 K	2.1 - 2.3	21 - 23
Intermediate plate (shift lock)	Plug	M 14x1.5	4.6	2.2 - 2.5	22 - 25
Front transmission cover (speedometer drive lock)	Hexagon head bolt	M 8x1.25	8.8	1.6 - 1.8	16 - 18
Front transmission cover (9 mm parking lock ball dia.)	Plug	M 12x1.5	5.8	3.0 - 3.5	30 - 35
Angle drive in guide sleeve	Hollow bolt	M 24x1.5	6.8	2.2 - 2.4	22 - 24
Drive shaft	Hexagon nut	M 24x1.5	6.9	10.0 - 12.0	100 - 120
Drive shaft	Collared nut	M 18x1.5	5.8	11.0 - 13.0	110 - 130
Drive pinion	Expansion bolt	M 12x1.5	10.9	11.0 - 12.0	110 - 120
Selector forks	Hexagon head bolt	M 8x1.25	8.8	2.2 - 2.6	22 - 26
Differential (ring gear mtgs.)	Hexagon head bolt	M 12x1.25	11.9	11.5 - 12.0	115 - 120
Joint flange (differential)	Expansion bolt	M 10x1.5	8.8	3.5 - 4.0	35 - 40
Front transmission cover Transmission support mtgs.	Hexagon nut	M 8x1.25	6.8	2.1 - 2.3	21 - 23

Sportomatic transmission specifications

Clutch

Hydrodynamic torque converter and a vacuum operated single plate dry clutch

Manual transmission: Porsche locking synchromesh

No. of gears: 3 forward, 1 reverse and parking lock

Shift scheme

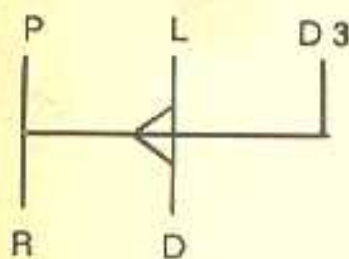

- P = Parking lock
- R = Reverse gear
- L = Low (driving range for steep gradients)
- D = Drive (driving range for city)
- D3 = Drive 3 (driving range for open roads)

Final drive ratio	8/27
Towing speed	approx. 40 km/h
Stall speed	1900 ± 200 rpm
Converter ratio	1.8
Clutch speed (at full throttle)	3200 ± 200 rpm
Transmission oil	approx. 2.5 ltr.

Front axle and steering specifications

	911	Carrera 3.0	Turbo
Wheel suspension	Independent employing control arms and shock absorber struts		
Springs	One round torsion bar in driving direction for each wheel		
Track width	1369 mm	1369 mm	1438 mm

Specifications and tolerances

At curb weight according to DIN 70020
Car with full fuel tank, spare wheel and tools

Designation	Adjustment data and tolerances	Max. difference between left and right
Front axle		
Height adjustment: Wheel center above middle of torsion bar		
911, Carrera	108 mm ± 5 mm	5 mm
911 S - USA (repair)	93 mm ± 5 mm	5 mm
Turbo	93.5 mm ± 5 mm (84.5 mm ± 5 mm USA)	5 mm
Total toe (pressed with 15 kp)	0°	-

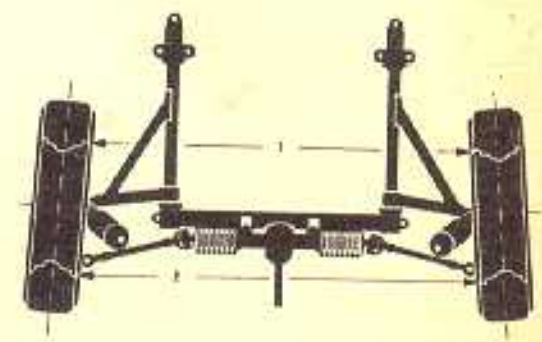
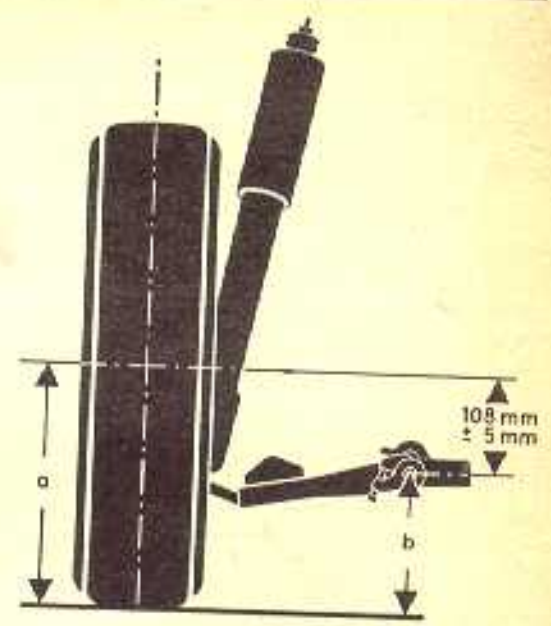

Designation	Adjustment data and tolerances	Max. difference between left and right
Difference angle at 20° lock (toward toe-in)	0° to 30'	Can only be influenced by exchanging steering arm.

A' = Parallel to A
B = Centerline of wheel
Y = Difference angle

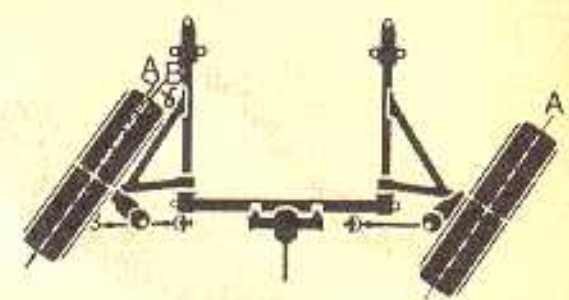

Camber of front wheels (wheels pointing straight ahead)

a = Camber angle		
911, Carrera, Turbo	0° ± 10'	10'
911 S - USA, Turbo - USA	+ 30' ± 10'	10'
β = Inclination of kingpin	11°	



Designation	Adjustment data and tolerances	Max. difference between left and right
-------------	--------------------------------	--

y = Caster $6^{\circ} 5' \pm 15'$ 30'

Caster results from total camber difference at 20° left lock and 20° right lock x 1.5

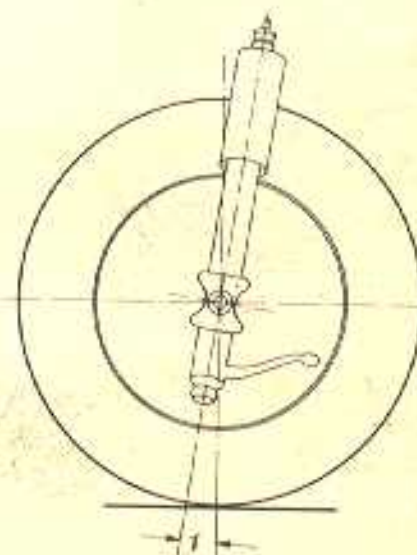

These wheel alignment specifications can also be applied to earlier models.

Tightening torque for front axle and steering

Location	Designation	Threads	Material	Tightening torque	
				kpm	Nm
Support bearing to strut	Hexagon nut	M 14x1.5	8	8	80
Clamp to tie rod	Hexagon nut	M 8	8.8	1.5	15
Support bearing to body	Fillister head bolt (socket)	M 10	8.8	4.7	47
Auxiliary carrier to body	Hexagon head bolt	M 12x1.5	8.8	9	90
Guard mountings	Hexagon head bolt	M 10	8.8	4.7	47
Guard mountings	Hexagon head bolt	M 8	8.8	2.5	25
Flan block mountings	Hexagon head bolt	M 10	8.8	4.7	47
Auxiliary carrier mountings	Hexagon head bolt	M 10	8.8	4.7	47
Steering gear mountings	Hexagon head bolt	M 10x20	8.8	4.7	47
Tie rod to steering gear	Hexagon head bolt	M 10	8.8	4.7	47
Stabilizer bearing to body	Hexagon head bolt	M 8	8.8	2.5	25
Stabilizer lever to stabilizer	Hexagon head bolt	M 8	8.8	2.5	25

Location	Designation	Threads	Material	Tightening torque	
				kpm	Nm
Clamping nut on steering knuckle	Fillister head bolt (socket)	M 7	10.9	1.5	15
Ball joint to strut	Uni-stop nut	M 8	8	2.2	22
Ball joint to strut	Hexagon head bolt	M 10x30	10.9	4.5	45
Ball joint to control arm (threads lubricated)	Slotted nut	M 45x1.5	8.8	25	250
Plug for spring strut (Boge)	Plug			12 + 2	120+20
Plug for spring strut (Koni)	Plug			20	200
Wheel to wheel hub	Wheel nut	M 14 x 1.5	10.9	13	130
Brake disc to wheel hub	Hexagon nut	M 8	M 8	2.3	23
Caliper to steering knuckle	Hexagon head bolt	M 8	M 8	1.0	10
Caliper to steering knuckle	Hexagon head bolt	M 12x1.5	8.8	7.0	70

Hollow bolt to caliper	Hollow bolt	M 10x1		2.0	20
Steering coupling to steering shaft	Hexagon head bolt	M 8	8.8	2.5	25
Steering shaft to steering gear	Hexagon head bolt	M 8	8.8	2.5	25
Steering shaft bearings	Fillister head bolt	M 8	8.8	2.5	25
Universal joint to steering shaft	Hexagon head bolt	M 8	8.8	2.5	25
Steering wheel	Hexagon nut	M 18x1.5	8	7.5	75
Dust cover holder to rack	Slotted nut	M 16x1.5	8	7.0	70
Ball joint to steering arm	Castle nut	M 10x1	8	4.5	45
Coupling flange to drive pinion	Hexagon nut (self-locking)	M 10	8	4.7	47
Case cover to steering gear	Hexagon head bolt	M 8x1	8.8	1.5	15
Tie rod to rack (only Turbo)	Ball joint	M 16x1.5	8.8	15	150

Rear axle specifications

	911	Carrera 3.0	Turbo
Wheel suspension	Independent, employing trailing arms, wheels driven by propeller shafts		
Springs	One round torsion bar in lateral direction for each wheel		
Track width (wheel center 12 mm below center of cross tube)	1354 mm with rim 6 J x 15	1380 mm with rim 7 J x 15	1511 mm with rim 8 J x 15 or 8 J x 16 (1977 models)
Shock absorbers	Double action, hydraulic shock absorbers		
Stabilizers front/rear dia. in mm	16/-	20/18	18/18 20/18 (1977 models)

Specifications and tolerances

(at curb weight according to DIN 70020; car with full fuel tank, spare wheel and tools)

Designation	Adjustment data and tolerances	Max. difference betw. left and right
-------------	--------------------------------	--------------------------------------

Torsion bar specification

Inclination of spring strut		
Coupe 911, Carrera	38°	
Coupe 911 S - USA	42°	
Targa	+ 0.5°	

Designation	Adjustment data and tolerances	Max. difference betw. left and right
-------------	--------------------------------	--------------------------------------

Air conditioner	+ 0.5°	
Sportomatic	+ 0.5°	
911, Carrera with Bielstein shock absorbers	37°	
911 S - USA with Bielstein shock absorbers	41°	
Turbo	31°	
Turbo - USA	34°	

Camber of rear wheels

911, Carrera	- 1° ± 10'	20'
Turbo	- 50' ± 10'	20'
911 S - Turbo - USA	0° ± 10'	20'
Track for all types	+ 10' ± 10' each wheel	20'

Height adjustment

Wheel center below center of cross tube	
911, Carrera, Turbo	12 mm ± 5 mm
911 S - Turbo - USA	37 mm ± 5 mm

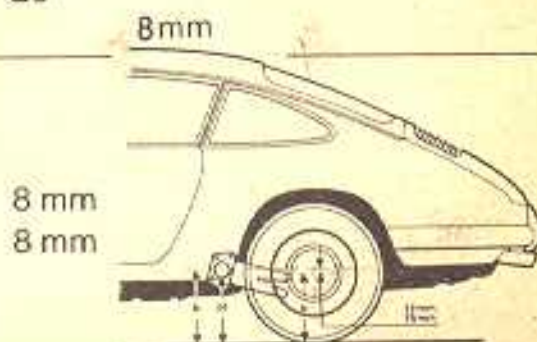

1° change in spring strut inclination = approx. 8 - 9 mm change in vehicle height.

Tightening torque for bolts and nuts of rear axle

Location	Designation	Threads	Material	Tightening torque	
				kpm	Nm
Bearing cover to body	Hexagon head bolt	M 10	8.8	4.7	47
Control arm to cross tube	Hexagon head bolt	M 14x1.5	10.9	6.0	60
Spring strut to contr. arm	Eccentric	M 12x1.5	8.8	6.0	60
Spring strut to contr. arm	Hexagon head bolt	M 12x1.5	10.9	9.5	95
Brake caliper to contr. arm	Hexagon head bolt	M 12x1.5	8.8	6.0	60
Shock absorber to contr. arm	Hexagon head bolt	M 14x1.5	8.8	12.5	125
Shock absorber to body	Hexagon nut	M 10x1	8	2.5	25
Brake hose to lines	Brake hose	M 10x1		1.5	15
Stabilizer to body	Hexagon head bolt	M 8	8.8	2.5	25
Propeller shaft flange	Fillister head bolt	M 10	12.9	8.3	83
Parking brake to contr. arm	Hexagon head bolt	M 8	8.8	2.5	25
Wheel to wheel hub	Wheel nut	M 14x1.5		13	130
Wheel hub to drive shaft	Castle nut	M 20x1.5	10.9	30-35	300-350
Brake disc to wheel hub	Countersunk bolt	M 6	8.8	0.5	5
Parking brake cable to control arm	Hexagon head bolt	M 6	8.8	0.5	5
Adjusting lever to spring strut	Hexagon head bolt	M 16x1.5	10.9	24.5	245
Adjusting lever to spring strut	Eccentric bolt	M 16x1.5	10.9	24.5	245

General technical data

Designation	Specification	Wear limit
Tandem brake master cylinder		
Bore	19.05 mm dia.	
Stroke	18/13 mm	
Ratio at brake pedal	5.8 : 1	
Operating linkage/piston play	1 mm	

Brake system with brake pressure booster T 52

Tandem brake master cylinder	
Bore	20.64 mm dia.
Stroke	20/12 mm
Mean amplification factor	2.2 (Turbo 1.8)
Play at brake pedal with bled brakes and engine stopped	min. 10 mm
Ratio at brake pedal	5.2 : 1

Designation	Specification	Wear limit
Front wheel brakes		
Brake disc outside dia.	282.5 mm, inboard vent	
New thickness	20.0 mm or 20.5 mm	
Min. thickness after machining*	18.6 mm	18.0 mm
Thickness tolerance	max. 0.03 mm	
Brake disc lateral runout	max. 0.05 mm	
Lateral runout when installed	0.2 mm	
Caliper piston dia.	48 mm	
Pad thickness	10 mm (13 mm Turbo)	2.0 mm
Clearance	0.2 mm	
Pad area on each wheel	76 cm ²	
Rear wheel brakes		
Brake disc outside dia.	290 mm, inboard vent	
New thickness	20.0 mm	
Min. thickness after machining*	18.6 mm	18.0 mm
Thickness tolerance	max. 0.03 mm	

Brake disc lateral runout	max. 0.05 mm	
Lateral runout when installed	max. 0.2 mm	
Surface finish of brake disc after machining	max. 0.006 mm	
Caliper piston dia.	38 mm	
Pad thickness	10 mm	2.0 mm
Clearance	0.2 mm	
Pad area on each wheel	52.5 cm ²	

Parking brake

New brake drum dia.	180 mm	181.0 mm
Liner thickness		2.0 mm

Caliper versions

911, Carrera front: gray cast iron (A) rear: gray cast iron	Turbo front: aluminium rear: gray cast iron
---	---

* Brake discs may only be machined symmetrically, i.e. evenly on both sides.

Cross section drawing of tandem brake master cylinder (with warning device) (version without brake pressure booster and without permanent contact)

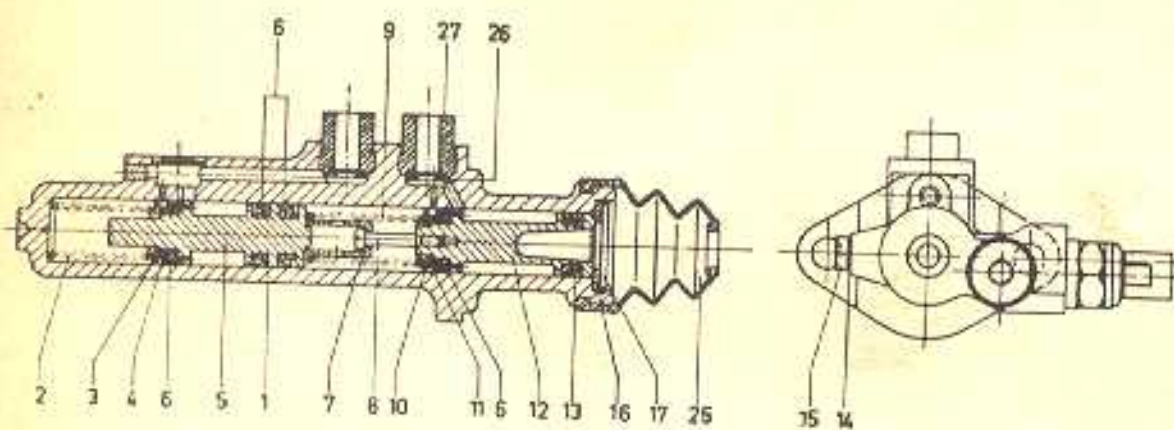

- 1 Housing
- 2 Spring for intermediate piston
- 3 Spring retainer
- 4 Support ring
- 5 Intermediate piston with filler disc
- 6 Primary cover
- 7 Stop sleeve
- 8 Stop screw for stroke limit
- 9 Spring for pressure piston

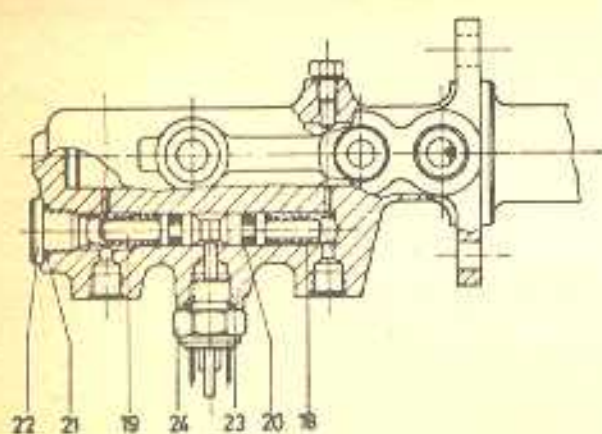

- 10 Spring retainer
- 11 Support ring
- 12 Pressure piston with filler disc
- 13 Grooved cover
- 14 Seal
- 15 Stop screw (outer)
- 16 Stop washer
- 17 Circlip
- 18 Spring
- 19 Piston
- 20 Cover
- 21 Round cord seal
- 22 Screw
- 23 Round cord seal
- 24 Brake warning switch
- 25 Guard
- 26 Washer
- 27 Container plug

Machining specifications and wear limits for brake discs and parking brake

Vehicle type	Type of brake disc	Location of brake disc	Distance „a“ (in ref. to new brake disc thickness)	New brake disc thickness	Min. thickness of brake disc after machining	Wear limit of brake disc (for symmetr. wear)
All	Vented brake disc		35 ± 0.1 mm	$20 - 0.2$ mm*	18.6 mm	18.0 mm (1.0 mm each side)
All	Vented brake disc		$76 + 0.2$ mm	$20 - 0.2$ mm	18.6 mm	18.0 mm (1.0 mm each side)
All	Thickness tolerance of brake discs				max. 0.03 mm	
All	Lateral runout of brake discs				max. 0.05 mm	
All	Surface finish of brake discs after machining				max. 0.006 mm	

* Was increased to $20.5 - 0.2$ mm.

Caution

Refinishing and wear specifications listed above are based on the assumption that the remaining thickness of the brake pad is not less than 2.0 mm. This pad thickness is required to assure perfect operation of brakes. (Installation of cross spring assures this.)

Only balanced brake discs are supplied. Brake discs are balanced by special clips in the cooling vents.

Caution! Never remove balance clips.

Parking brake

Brake drum dia. (new)	$180 + 0.2$ mm
Brake drum wear limit	max. 181.0 dia.
Brake liner width	25 mm

Caution!

Parking brake liners must be at least 2.0 mm thick.

Caution

Machine brake disc symmetrically, i.e. uniformly on both sides. Arrows indicate brake disc reference or mounting points.

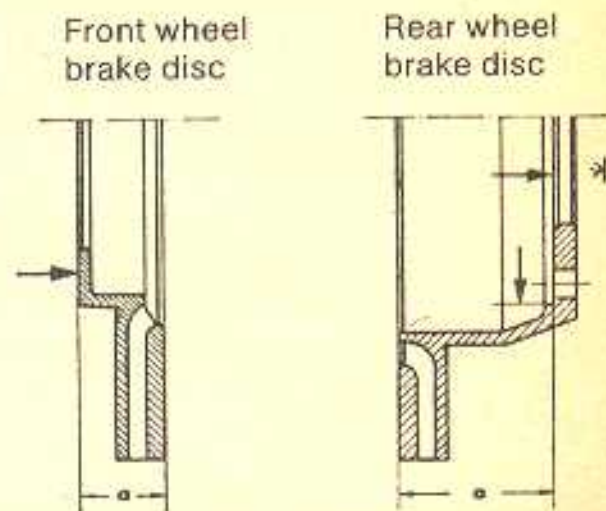

Brake circuit failure indicator

Tandem brake master cylinder with permanent contact (as from January, 1976)

With the new brake failure warning switch the brake indicator lamp remains in action when a brake circuit fails, even after completion of repairs. Consequently after elimination of the defect or damage the release cap of the switch will have to be pressed back to normal position.

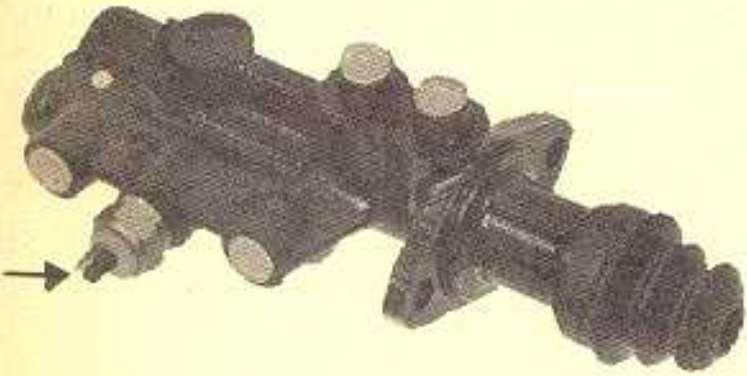

Tandem brake master cylinder with brake pressure booster

Each brake circuit has a stop light switch, which also fulfills the function of a brake warning switch. The brake indicator lamp comes on when a brake circuit fails.

After completion of repairs, the brake circuit failure indicator must be put out by detaching the battery.

Checking wheel rims

Measuring points for radial and lateral runout on inner and outer shoulders of wheel rim

Distance "a" = 8 mm

Max. permissible radial runout for steel rims

Max. permissible radial runout for aluminium rims

Max. permissible lateral runout for steel rims

Max. permissible lateral runout for aluminium rims

1.25 mm

1.00 mm

1.25 mm

0.80 mm

Caution!

Distorted rims cannot be straightened.

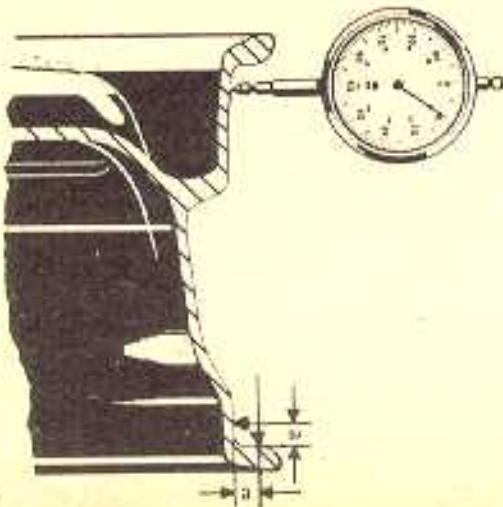

Tire pressures (reference values)

Measured on cold tire

Pressure in bar (kp/cm²)

Front

2.0

Rear

2.4

All tire sizes

These values also apply to winter tires.

Rims and tires

Type	Standard rims	Tires	Approved rims	Tires
1976 Models 911	LMg 6 J x 15	185/70 VR 15	Lmgs 6 J x 15	185/70 VR 15
			Winter tires 5 1/2 J x 15 } 6 J x 15 } 4 1/2 J x 15 } 5 1/2 J x 15 } 5 1/2 J x 14 }	185/70 SR 15 M + S 165 SR 15 M + S 185 SR 14 M + S
Carrera	front LMgs 6 J x 15 rear LMgs 7 J x 15	185/70 VR 15 215/60 VR 15	front LMgs 7 J x 15	185/70 VR 15
			rear LMgs 8 J x 15	215/60 VR 15 or 185/70 VR 15
			front LMgs 6 J x 15	205/50 VR 15
			rear LMgs 7 J x 15	225/50 VR 15*
			front LMgs 7 J x 15	205/50 VR 15
			rear LMgs 8 J x 15	225/50 VR 15*
			Winter tires 5 1/2 J x 15 } 5 1/2 J x 14 } 5 1/2 J x 15 } 6 J x 15 } 7 J x 15 }	165 SR 15 M + S 185 SR 14 M + S 185/70 SR 15 M + S

* with adapted speedometer

Type	Standard rims	Tires	Approved rims	Tires
Turbo	front LMgs 7 J x 15 rear LMgs 8 J x 15	205/50 VR 15 225/50 VR 15	front LMgs 7 J x 15	185/70 VR 15
			rear LMgs 8 J x 15	215/60 VR 15 (in conjunction with transmission 930/30 and adapted speedometer)
			Winter tires 5 1/2 J x 14 } 6 J x 15 } rear 7 J x 15 } 5 1/2 J x 14 }	185 SR 14 M + S 185/70 SR 15 M + S *185/70 SR 14 M + S

*Only for cars which are equipped with 15" series 50 summer tires.

1977 Models	Standard rims	Tires	With wider fenders as Carrera	Tires
911	LMg 6 J x 15	185/70 VR 15	front 6 J x 15	185/70 VR 15
			rear 7 J x 15	
			front 7 J x 15	185/70 VR 15
			rear 7 J x 15	
			front 6 J x 15	185/70 VR 15
			rear 7 J x 15	215/60 VR 15
			front 7 J x 15	185/70 VR 15
			rear 8 J x 15	215/60 VR 15
			front 6 J x 16	205/55 VR 16
			rear 7 J x 16	225/50 VR 16

Winter tires same as for 1976 models.

Rims and tires

Type	Standard rims	Tires	Approved rims	Tires
Carrera	front LMg 6J x 15	185/70 VR 15	front 7J x 15	185/70 VR 15
	rear LMg 7J x 15	215/60 VR 15	rear 8J x 15	215/60 VR 15
			front 6J x 16	205/55 VR 16
			rear 7J x 16	225/50 VR 16
Turbo	front LMgs 7 J x 16	205/55 VR 16	front 7 J x 15	185/70 VR 15
	rear LMgs 8 J x 16	225/50 VR 16	rear 8 J x 15	215/60 VR 15
			Winter tires	
			5 1/2 J x 14	185 SR 14 M+S
			6 J x 15	185/70 SR 15 M+S
			rear 7 J x 15	

LMg = Cast aluminum

LMgs = Forged aluminum

Tightening torque for front and rear wheel brakes

Location	Designation	Threads	Material	Tightening torque	
				kpm	Nm
Tandem brake master cylinder to cross panel	Hexagon nut	M 8	8.8	2.5	25
Piston rod to connector	Hexagon nut (flat)	M 10	C 45/6	1.0	10
Brake line	Hexagon hollow bolt	M 10 x 1	5.8	1.5	15
Hollow bolt to caliper	Hollow bolt	M 10 x 1		2.0	20
Caliper to steering knuckle	Hexagon head bolt	M 12 x 1.5	8.8	7.0	70
Clamping nut to steering knuckle	Fillister head bolt (socket)	M 7	10.9	1.5	15
Brake disc to wheel hub	Hexagon nut	M 8	8.8	2.3	23
Brake disc guard (front)	Hexagon head bolt	M 8	8.8	1.0	10
Case bolt for caliper (front)	Fillister head bolt	M 8	10.9	3.4	34
Case bolt for caliper (rear)	Fillister head bolt	M 6	12.9	2.2	22
Caliper to rear control arm	Hexagon head bolt	M 12 x 1.5	8.8	7.0	70
Brake disc to rear wheel hub	Countersunk bolt	M 6	8.8	0.5	5
Brake backplate to rear control arm	Hexagon head bolt	M 10		4.7	47
Guard to brake backplate	Hexagon head bolt	M 8	8.8	2.5	25
Parking brake cable to control arm	Hexagon head bolt	M 6	8.8	0.5	5
Wheel to wheel hub	Spherical collared nut	M 14 x 1.5		13.0	130
Bleeder valve in caliper (wrench size 7 mm)	-	-	-	0.3	3

Fuse chart for 911 and Carrera 3.0

Fuse no.	Fused equipment	Amps
1	Fog lights	16
2	License plate light, fog light indicator lamp and relay	5
3	Front and rear right marker lights	5
4	Front and rear left marker lights, engine compartment light	5
5	Right low beam headlight	8
6	Left low beam headlight	8
7	Right high beam headlight	8
8	Left high beam headlight, high beam indicator lamp	8
9	Right front turn signal	5
10	Left front turn signal	5
11	Left and right stop lights, flasher relay, backup lights	16
12	Rear window defogger relay, heater blower, rear window defogger indicator lamp	25
13	Windshield wipers, washer pump, air conditioner	25
14	Electric sliding roof, rear window wiper, outside mirror	25
15	Cigar lighter, blower switch indicator lamp	16
16	Electric window controls	25
17	Hazard lights	16
18	Courtesy light, clock, glove box light, trunk light	5
19	Headlight cleaners	16
20	Blower for air conditioner	25
21	Fuel pump	16
Fuses in engine compartment		
1	Sportomatic, heater blower relay	5
2	Heater blower	25
3	Rear window defogger	25
Relays in fuse box		
1	Air conditioner	4 Not occupied
2	Fog lights	5 Window controls
3	Horn	6 Not occupied
		7 Fuel pump
Relays in engine compartment		
1	Heater blower	
2	Rear window defogger (for only one heating circuit)	

Fuse chart for Turbo

Fuse no.	Fused equipment	Amps
1	Fog lights	16
2	License plate lights, fog light indicator lamp and relay	5
3	Front and rear right marker lights	5
4	Front and rear left marker lights, engine compartment light	5
5	Right low beam headlight	8
6	Left low beam headlight	8
7	Right high beam headlight	8
8	Left high beam headlight, high beam indicator lamp	8
9	Right front turn signal	5
10	Left front turn signal	5
11	Flasher relay, backup lights	16
12	Left and right stop lights, blower, rear window defogger indicator lamp, relay for windshield and rear window defoggers	25
13	Windshield wipers, washer pump, air conditioner	25
14	Electric sliding roof, rear window wiper, outside mirror	25
15	Cigar lighter, blower switch indicator lamp	16
16	Electric window controls	25
17	Hazard lights	16
18	Courtesy light, clock, glove box light, trunk light	5
19	Headlight cleaners	16
20	Air conditioner blower	25
21	Windshield defogger	16
	Rear window defogger (in engine compartment)	25
Relays in fuse box		
1	Air conditioner	4 Not occupied
2	Fog lights	5 Window controls
3	Horn	6 Fuels pump 1
		7 Fuel pump 2
Relays in engine compartment		
	Air sensor and charge pressure safety switch	

Bulb chart

	Wattage	Base (DIN)
Main headlight (halogen) H 4	60/55 W	P 43 t - 38
Extra headlight (halogen) H 3	55 W	PK 22 S
Fog light (halogen) H 3	55 W	PK 22 S
Stop light/tail light	21/5 W	BAY 15 d
Turn signal	21 W	BA 15 S
Backup light	21 W	BA 15 S
Courtesy light, engine compartment light	10 W	SV 8.5 - 8
Tail fog light	18 W	SV 8.5 - 8
Trunk light	10 W	BA 15 S
Marker light	4 W	BA 9 S
Instrument light, indicator lamps	2 W	BA 7 S
Glass socket indicator lamps	1.2 W	W 2 x 4.6 d
License plate light	5 W	BA 15 S
		Base (SAE)
Sealed beam headlight, USA (right hand traffic)	60/50 W	6014
Sealed beam headlight (left hand traffic)	60/50 W	7002
Stop light/tail light (USA)	32/3 cp	1034
Turn signal/marker light (USA)	32/3 cp	1034
Turn signal (USA)	32 cp	1073
Backup light	15 cp	1003
Side marker light (USA), license plate light (USA)	2 cp	1895

Dimensions at curb weight according to DIN

		911	Carrera	Turbo
Wheelbase	mm	2272	2272	2272
Front track width	mm	1369	1369	1438
Rear track width	mm	1354	1380	1511
Length	mm	4291	4291	4291
Width	mm	1610	1652	1775
Height	mm	1320	1320	1320
Weights				
Curb weight acc. to DIN	ca. kg	1120	1120	1195
Gross vehicle weight	ca. kg	1440	1440	1525
Max. axle load, front/rear	kg	600/840	600/840	625/900
Max. trailer load, w/o brakes **	kg	480	480	-
Max. trailer load, with brakes**	kg	800	800	-
Max. roof load (only coupe)*	kg	35	35	35

* But without exceeding the gross vehicle weight.

** For gradients up to 16%.

Filling capacities

		911	Carrera	Turbo
Engine		Brand name heavy duty oils according to API classification SE of viscosity SAE 10 W/50, 15 W/50, 20 W/50. Only use well known oil makes, which have been tested and approved by Porsche. Single grade oils are also permissible, but then the oil must be changed according to the seasons of the year (temperature - summer/winter) in addition to the normal change intervals. Summer SAE 30, winter SAE 20, at permanent temperatures from - 15°C to 0°C SAE 20 W/20 or SAE 10 W at permanent temperatures below - 15°C.		
Total oil capacity	ca. ltr.	13	13	13
With sportomatic transmission	ca. ltr.	2 more	2 more	-
Oil change quantity	ca. ltr.	10	10	10
Transmission*	ca. ltr.	3.0	3.0	3.7 [†]
Sportomatic/manual transmission	ca. ltr.	2.5	2.5	-
Fuel tank	ca. ltr.	80	80	80
Brake fluid tank	ca. ltr.	0.2	0.2	0.2
Windshield washer	ca. ltr.	8.5	8.5	8.5

* SAE 90 meeting specifications of API-GL 5 or Mil-L 2105 B. For locking differential with **80% locking factor** oil meeting Ford Specification M 2 C 28 B.

Performances, consumption of fuel and oil

		911	Carrera	Turbo
Top speed	km	above 210 only slight deviation for models with sportomatic transmission	above 230	above 250 -
Acceleration at DIN curb weight plus 1/2 payload	0-100 km/h	7.8 sec	6.5 sec	5.5 sec
Kilometer from standing start		29 sec	27 sec	24 sec
Fuel consumption in mixed traffic	ca. l/100 km	13 - 15	14 - 16	14 - 18
Engine oil consumption	ca. l/1000 km	1.5 to 2.0	1.5 to 2.0	1 to 2

Dimensions for Type 911 – 1976/1977 models

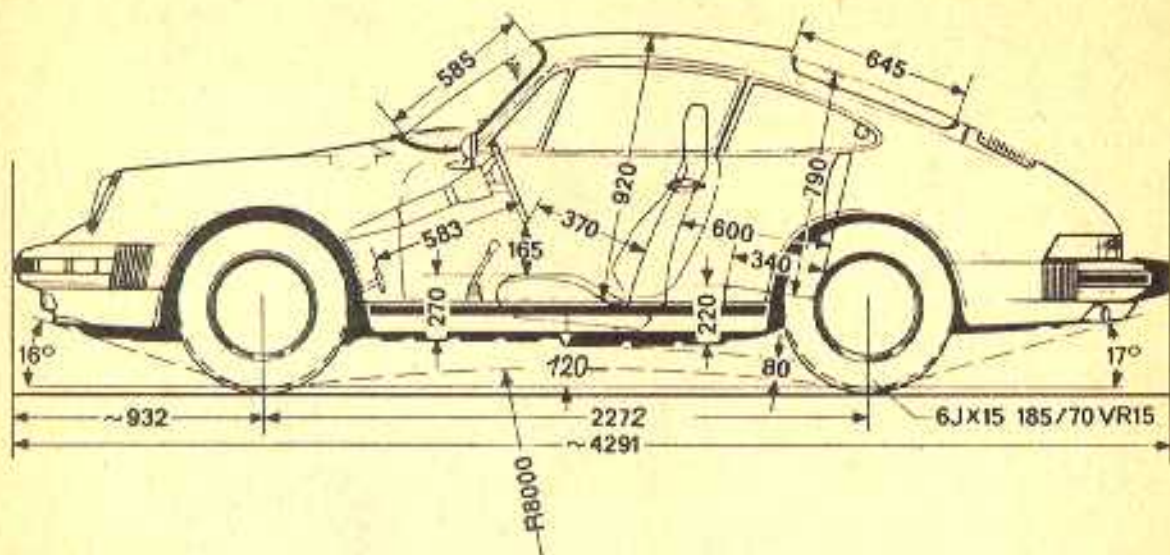

The specifications for overhang angles, curved and normal ground clearances apply to cars at full load.

