

# 1966 BUICK

Chassis Service Manual  
All Series

# 1966 BUICK CHASSIS SERVICE MANUAL

This manual contains chassis service information for all 1966 Buick models. Refer to the Introduction for a description of the arrangement of this manual. This will enable you to locate desired information easily.



INDEX		
GROUP NO.	SUBJECT	PAGE NO.
0	GENERAL INFORMATION, MAINTENANCE, AND LUBRICATION	00-1
1	HEATING AND AIR CONDITIONING	10-1
2	FRAME AND BODY MOUNTINGS	20-1
3	FRONT SUSPENSION	30-1
4	REAR SUSPENSION, PROPELLER SHAFT AND DIFFERENTIAL	40-1
5	BRAKES	50-1
6	ENGINE	60-1
7	TRANSMISSIONS AND CLUTCH	70-1
8	FUEL TANK AND EXHAUST	80-1
9	STEERING	90-1
10	WHEELS AND TIRES	100-1
11	CHASSIS SHEET METAL	110-1
12	CHASSIS ELECTRICAL AND INSTRUMENTS	120-1
13	RADIATOR AND GRILLE	130-1
14	BUMPERS	140-1
15	ACCESSORIES	150-1

Buick Motor Division  
General Motors Corporation  
Flint, Michigan 48550

© General Motors Corporation, 1965

# INTRODUCTION

The 1966 Buick Chassis Service Manual has been reorganized to correspond more closely with current servicing techniques. The various chassis components and systems have been classified into the sixteen major areas listed on the previous page. Each area corresponds to a GROUP with the exception of the 6th and 7th areas which are comprised of more than one GROUP.

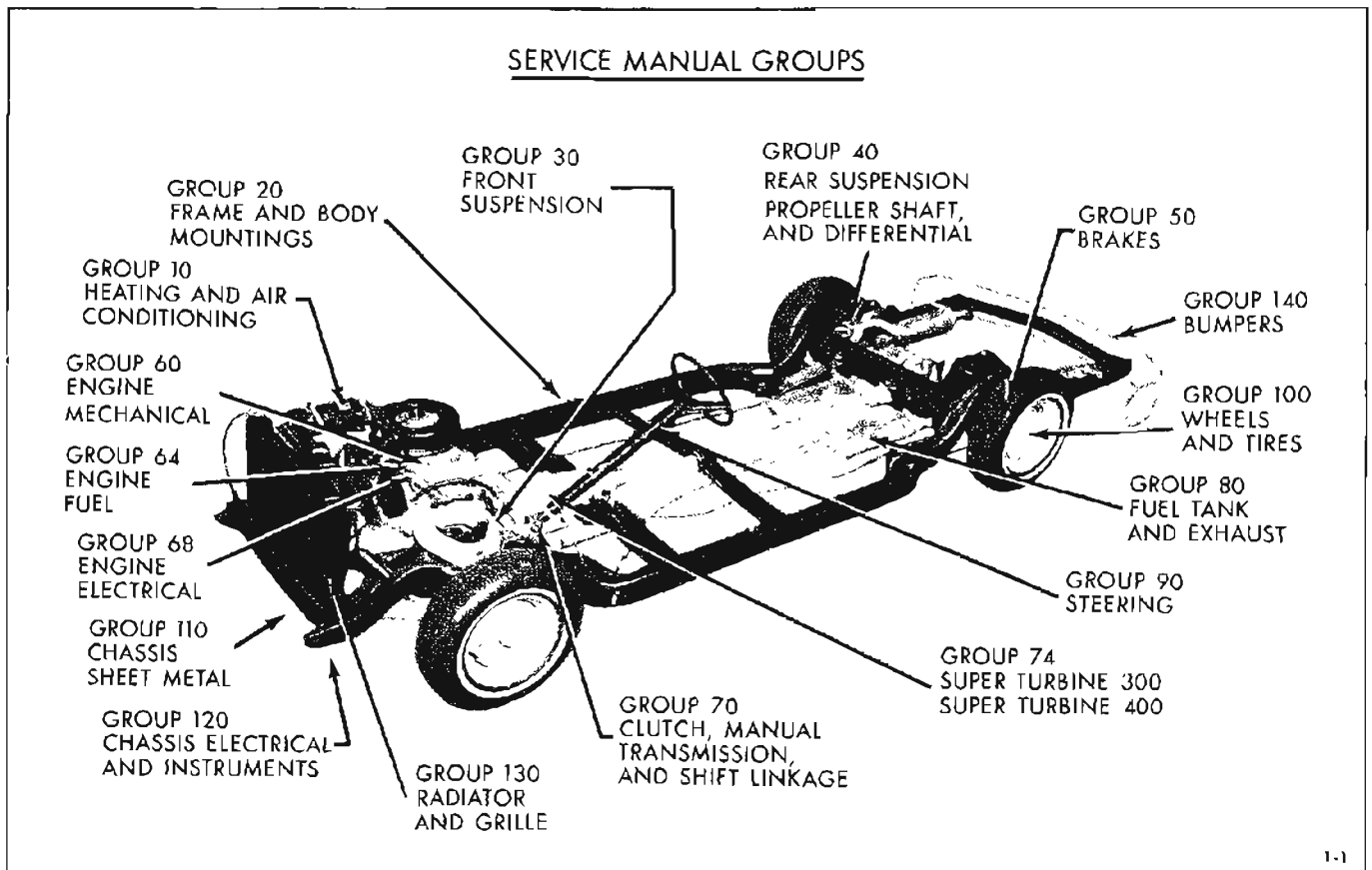

Every GROUP contains one or more SECTIONS. Each SECTION deals with a specific version of a component or system. For instance, since there are major differences between the 225 cubic inch V-6 and the 401 cubic inch V-8, each engine will be treated in separate SECTIONS of GROUP 60.

The service information included in a SECTION is divided into four basic DIVISIONS. The titles of each DIVISION are:

Division	Area
I	Specifications and Adjustments
II	Description and Operation
III	Service Procedures
IV	Trouble Diagnosis

SECTION	TITLE	PAGE
A	225 CUBIC INCH V-6 ENGINE	
B	300 & 340 CUBIC INCH V-8 ENGINE	
C	400, 401, & 425 CUBIC INCH V-8 ENGINE	

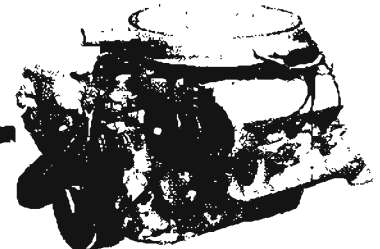
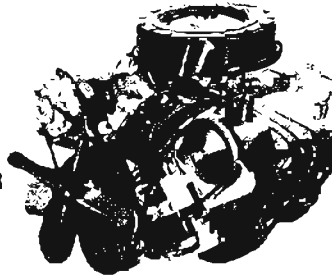
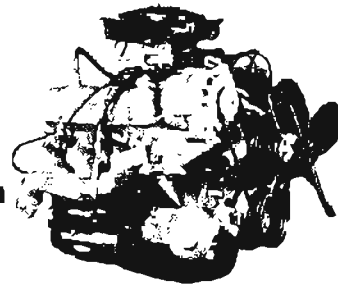

1-2

A DIVISION contains one or more PARAGRAPHS which can be identified by the series of numbers preceding them. The PARAGRAPH number consists of the GROUP number, a hyphen, and a sequence number; paragraph arrangement is numerical.

SUB-PARAGRAPHS are used when necessary for clarity or to provide distinction between models. SUB-PARAGRAPHS are designated by a letter and are in alphabetical order.

#### SPECIAL TOOLS

References are made throughout the manual to special tool numbers, designated by the prefix letter "J". These tools are manufactured by the Kent-Moore Organization, Inc. If equivalent special tools are not available locally, they may be obtained through:

Kent-Moore Organization, Inc.  
28635 Mound Rd.  
Warren, Michigan 48092

#### LOCATING DESIRED INFORMATION

To locate any desired information, locate the proper GROUP listed on the front page of the manual. Bend the manual until the black tab on the first page of the GROUP can be seen in line with the GROUP title on the front page. The first page of the GROUP lists the SECTIONS contained therein. Turn to the proper SECTION, locate the desired DIVISION, and note the page number of the PARAGRAPH containing the information you are seeking.

# 0

## **GENERAL INFORMATION, MAINTENANCE, AND LUBRICATION**

# GROUP 00

## GENERAL INFORMATION, MAINTENANCE, AND LUBRICATION

Section	Title	Page
<b>A</b>	All Series - General Information . . .	00-2
<b>B</b>	All Series - Maintenance . .	00-7

# SECTION A

## GENERAL INFORMATION

### ALL SERIES

#### CONTENTS

Division	Paragraph	Subject	Page
I		SPECIFICATIONS AND ADJUSTMENTS	
	00-1	1962 Model Chart . . . . .	00-2
	00-2	Standard Rear Axle Ratios . . . . .	00-3
	00-3	Vehicle and Component Identification Numbers . . . . .	00-3
	00-4	Paint Color Codes . . . . .	00-5
	00-5	Tire Sizes . . . . .	00-5
	00-6	General Specifications . . . . .	00-6
II		DESCRIPTION AND OPERATION	
		Not Applicable	
III		SERVICE PROCEDURES	
		Not Applicable	
IV		TROUBLE DIAGNOSIS	
		Not Applicable	

### DIVISION I SPECIFICATIONS AND ADJUSTMENTS

#### 00-1 1962 MODEL CHART

Series	Body Style	Designation	
		V-6	V-8
Special	2-Door Coupe Thin Pillar . . . . .	43307	43407
	4-Door 2-Seat Wagon . . . . .	43335	43435
	2-Door Convertible . . . . .	43367	43467
	4-Door Sedan Thin Pillar . . . . .	43369	43469
Special Deluxe	2-Door Coupe Thin Pillar . . . . .	43507	43607
	2-Door Coupe Hardtop . . . . .	43517	43617
	4-Door 2-Seat Wagon . . . . .	43535	43635
	4-Door Sedan Thin Pillar . . . . .	43569	43669
Skylark	2-Door Coupe Thin Pillar . . . . .	44307	44407
	2-Door Coupe Hardtop . . . . .	44317	44417
	4-Door Hardtop . . . . .	44339	44439
	2-Door Convertible . . . . .	44367	44467
Skylark Gran Sport	2-Door Coupe Thin Pillar . . . . .		44607
	2-Door Coupe Hardtop . . . . .		44617
	2-Door Convertible . . . . .		44667
Sport Wagon	4-Door 2-Seat Wagon . . . . .		44255
	4-Door 3-Seat Wagon . . . . .		44265
Sport Wagon Custom	4-Door 2-Seat Wagon . . . . .		44455
	4-Door 3-Seat Wagon . . . . .		44465
LeSabre	2-Door Coupe Hardtop . . . . .		45237
	4-Door Hardtop . . . . .		45239
	4-Door Sedan Thin Pillar . . . . .		45269

00-1 1966 MODEL CHART (Cont'd.)

Series	Body Style	Designation	
		V-6	V-8
LeSabre Custom	2-Door Coupe Hardtop . . . . .		45437
	4-Door Hardtop . . . . .		45439
	2-Door Convertible . . . . .		45467
	4-Door Sedan Thin Pillar . . . . .		45469
Wildcat	2-Door Coupe Hardtop . . . . .		46437
	4-Door Hardtop . . . . .		46439
	2-Door Convertible . . . . .		46467
	4-Door Sedan Thin Pillar . . . . .		46469
Wildcat Custom	2-Door Coupe Hardtop . . . . .		46637
	4-Door Hardtop . . . . .		46639
	2-Door Convertible . . . . .		46667
Electra 225	2-Door Coupe Hardtop . . . . .		48237
	4-Door Hardtop . . . . .		48239
	4-Door Sedan Semi-Thin Pillar . . . . .		48269
Electra 225 Custom	2-Door Coupe Hardtop . . . . .		48437
	4-Door Hardtop . . . . .		48439
	2-Door Convertible . . . . .		48467
	4-Door Sedan Semi-Thin Pillar . . . . .		48469
Riviera	2-Door Coupe Hardtop . . . . .		49487

00-2 STANDARD REAR AXLE RATIOS

Series	Models	Engine	Transmission	Ratio
Special & Special Deluxe	All Except Station Wagons . . . . .	V-6	Manual	3.23
		V-6	Automatic/Less AC	2.93
		V-6	Automatic/With AC	3.23
		V-8	Manual	3.08
		V-8	Automatic	2.78
Special & Special Deluxe	Station Wagons . . . . .	V-6	Manual	3.36
		V-6	Automatic	3.23
		V-8	Manual	3.23
		V-8	Automatic	2.93
Skylark	All . . . . .	V-6	Manual	3.23
		V-6	Automatic/Less AC	2.93
		V-6	Automatic/With AC	3.23
		V-8	Manual	3.08
		V-8	Automatic	2.78
Skylark Gran Sport	All . . . . .	V-8	Manual	3.36
		V-8	Automatic	2.93
Sportwagons	All . . . . .	V-8	Manual	3.36
		V-8	Automatic	3.23
LeSabre	All . . . . .	V-8	Manual	3.36
		V-8	Automatic/Less AC	2.93
		V-8	Automatic/With AC	3.08
Wildcat	All . . . . .	V-8	Manual	3.23
Wildcat Gran Sport	All . . . . .	V-8	Automatic	3.23 P.T.
Wildcat-Electra 225	All . . . . .	V-6	Automatic	3.07
Riviera	All . . . . .	V-8	Automatic	3.07
Riviera Gran Sport	All . . . . .	V-8	Automatic	3.23

00-3 VEHICLE AND MAJOR COMPONENT IDENTIFICATION NUMBERS

a. Vehicle Identification Numbers

1966 Buick models have a serial number identification plate at-

tached to the left front body hinge pillar. An example of this plate is shown in Figure 00-1.

b. Fisher Body Number Plate

Body identification is provided by the Fisher Body Number Plate.

Information such as style and body numbers, trim numbers, and paint color code is contained on this plate. Refer to the 1966 Fisher Body Service Manual for detailed information about this plate.

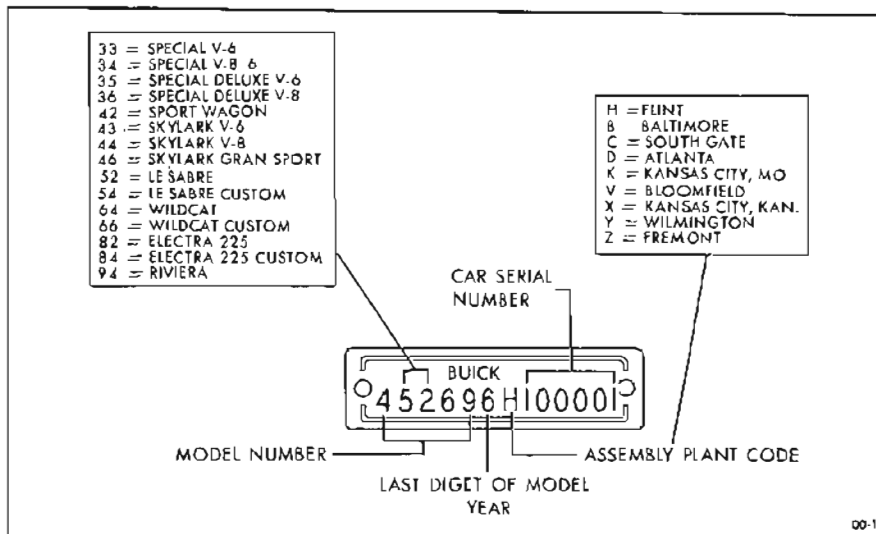

Figure 00-1—Vehicle Identification Plate

c. Engine Numbers

1966 Buick engines are stamped with two different identification codes. One is an engine production code number. This identifies the engine and its approximate production date.

The other code is the engine serial number and is the same number found on the vehicle identification plate mentioned previously in Paragraph a. This is the legal engine number and is used on registrations, titles, and other legal documents, while the production code number is used to identify the engine on product reports and other factory correspondence.

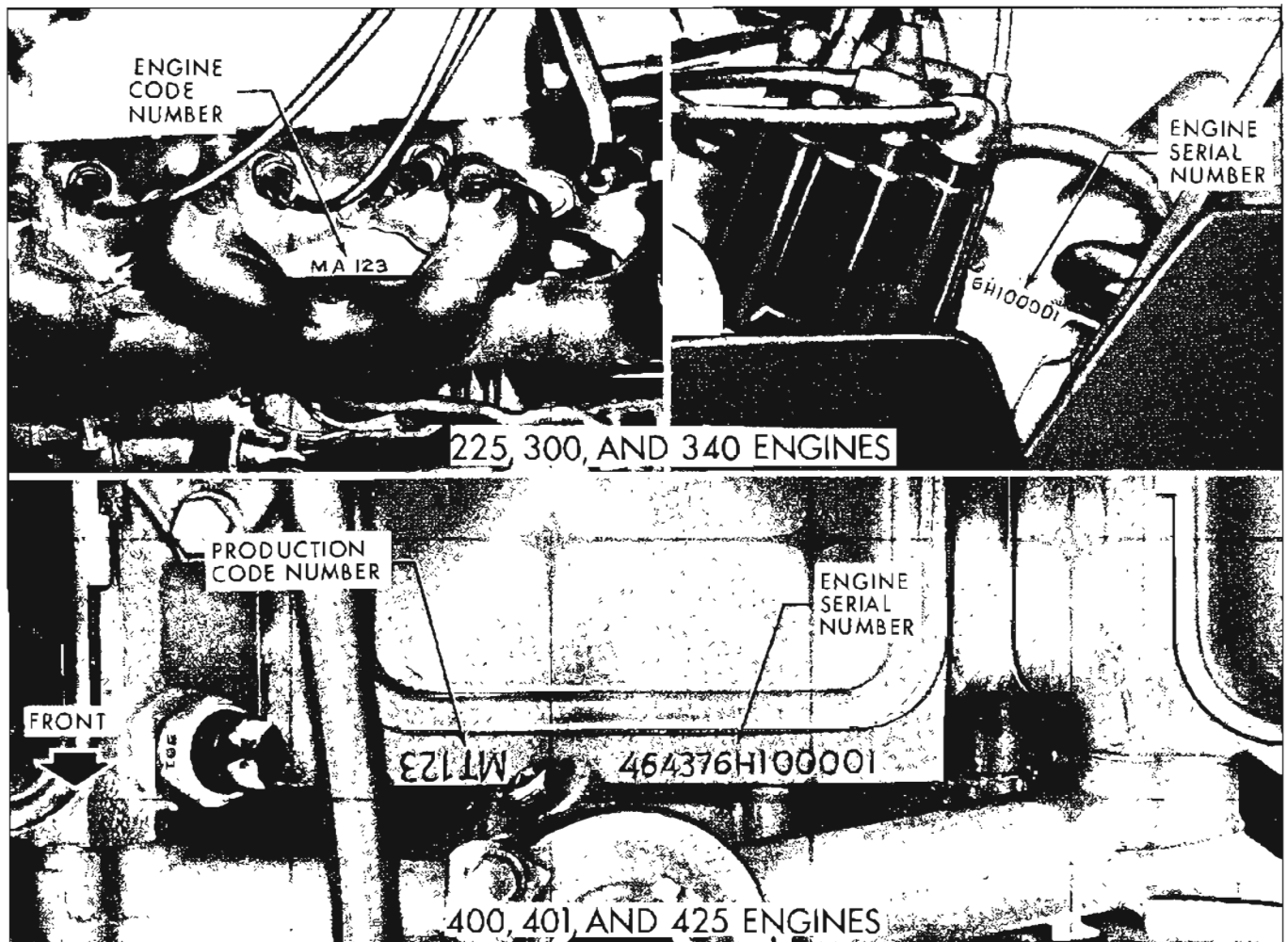

Figure 00-2—Engine Serial Number and Production Code Location

d. Automatic Transmission Identification Numbers  
Refer to Figure 00-3.

e. Manual Transmission Identification Numbers  
Refer to Figure 00-4.

00-4 PAINT COLOR CODE CHART

Code Letter	Color Name
A	Regal Black
C	Artic White
D	Astro Blue
E	Midnight Blue
F	Blue Mist
H	Seafoam Green
J	Verde Green
K	Turquoise Mist
L	Shadow Turquoise
N	Burgundy Mist
R	Flame Red
T	Saddle Mist
V	Shell Beige
W	Silver Mist
Y	Cream

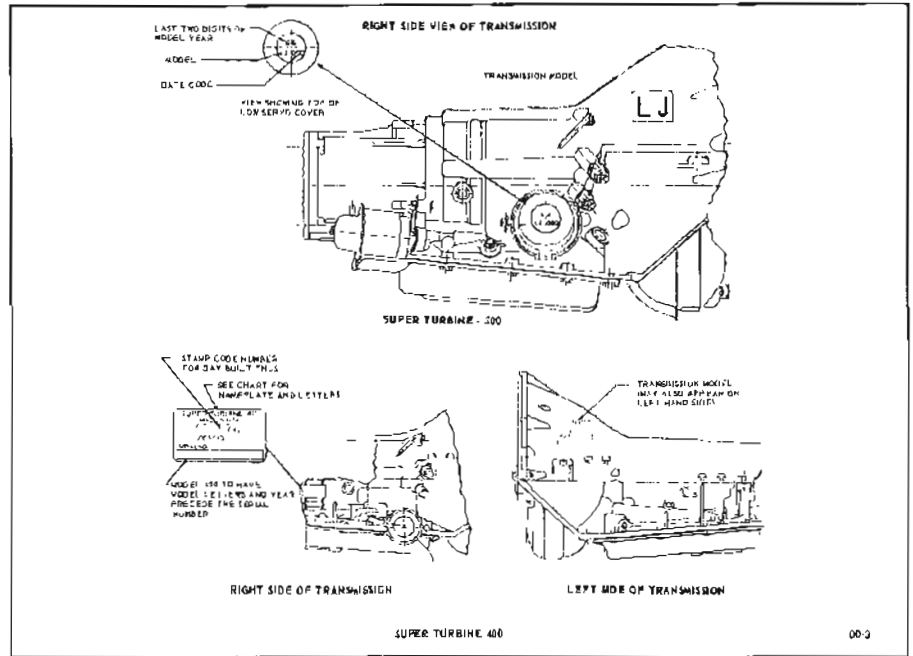

Figure 00-3—Automatic Transmission Identification Numbers

00-5 TIRE SIZES

Series	Models	Standard Tire	Optional Tire
Special V-6	Coupes & Pillar Sedans without		
Special Deluxe V-6	Air Conditioning . . . . .	6.95 x 14	7.35 x 14
Skylark V-6			
Special V-6	Coupes & Pillar Sedans with AC &		
Special Deluxe V-6	All Convertibles & 4-Door Hardtops . . . . .	7.35 x 14	7.75 x 14
Skylark V-6			

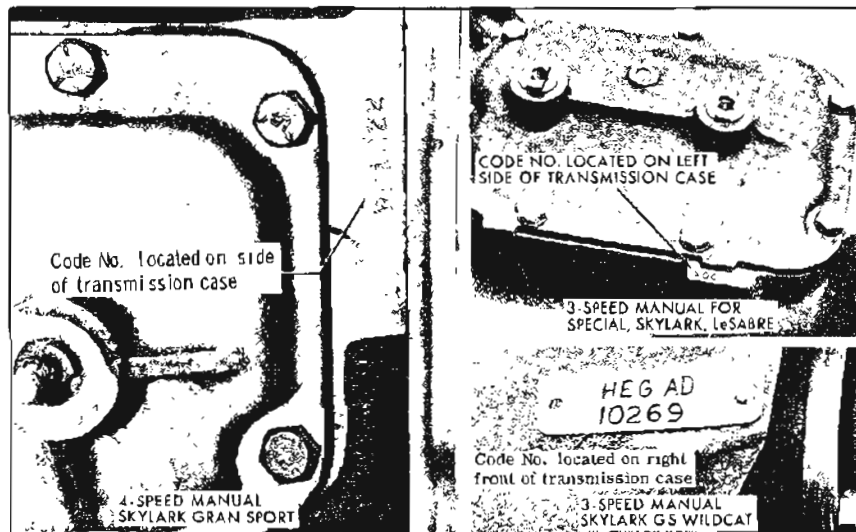

Figure 00-4—Manual Transmission Identification Numbers

00-5 TIRE SIZES (Cont'd.)

Series	Models	Standard Tire	Optional Tire
Special V-6 Special Deluxe V-6	Station Wagons . . . . .	7.75 x 14	8.25 x 14
Special V-8 Special Deluxe V-8 Skylark V-8	Sedans, Coupes, and Convertibles . . . . .	7.35 x 14	7.75 x 14
Special V-8 Special Deluxe V-8	Station Wagons . . . . .	7.75 x 14	8.25 x 14
Sportwagon	All . . . . .	8.25 x 14	8.25 x 14 (4 Ply, 8 Ply Rating)
Skylark Gran Sport	All . . . . .	7.75 x 14	8.25 x 14
LeSabre	All . . . . .	8.15 x 15	8.45 x 15
Wildcat	All . . . . .	8.45 x 15	8.85 x 15
Electra 225	All . . . . .	8.85 x 15	N.A.
Riviera	All . . . . .	8.45 x 15	N.A.

00-6 GENERAL SPECIFICATIONS

a. Special, Special Deluxe, and Skylark

Sedan, Coupe, and Convertible

Wheelbase - 115" . . . . . Overall Height - 54"  
 Overall Length - 204" . . . . . Front Tread - 58"  
 Overall Width - 75" . . . . . Rear Tread - 58"  
 Rear Tread - 59" (Gran Sport)

Station Wagon

Wheelbase - 115" . . . . . Overall Height - 55.3"  
 Overall Length - 204" . . . . . Front Tread - 58"  
 Overall Width - 75" . . . . . Rear Tread - 58"

b. Sportwagon

Wheelbase - 120" . . . . . Overall Height - 57.6"  
 Overall Length - 209" . . . . . Front Tread - 58"  
 Overall Width - 75" . . . . . Rear Tread - 59"

c. LeSabre

Wheelbase - 123" . . . . . Overall Height - 55.2"  
 Overall Length - 217" . . . . . Front Tread - 63"  
 Overall Width - 80" . . . . . Rear Tread - 63"

d. Wildcat

Wheelbase - 126" . . . . . Overall Height - 55.2"  
 Overall Length - 220.1" . . . . . Front Tread - 63.4"  
 Overall Width - 80" . . . . . Rear Tread - 63.0"

e. Electra 225

Wheelbase - 126" . . . . . Overall Height - 55.8"  
 Overall Length - 223.5" . . . . . Front Tread - 63.4"  
 Overall Width - 80" . . . . . Rear Tread - 63.0"

f. Riviera

Wheelbase - 119" . . . . . Overall Height - 53.4"  
 Overall Length - 211.2" . . . . . Front Tread - 63.5"  
 Overall Width - 78.8" . . . . . Rear Tread - 63.0"

# SECTION B

## MAINTENANCE AND LUBRICATION ALL SERIES

### CONTENTS

Division	Paragraph	Subject	Page
I	00-7	<b>SPECIFICATIONS AND ADJUSTMENTS:</b>  Lubrication Chart - 43000 Series . . . . . Lubrication Chart - 44000 Series . . . . . Lubrication Chart - 45000 Series . . . . . Lubrication Chart - 46-48000 Series . . . . . Lubrication Chart - 49000 Series . . . . .	  00-8 00-9 00-10 00-11 00-12
II		<b>DESCRIPTION AND OPERATION:</b>  Not Applicable	
III	00-8 00-9	<b>SERVICE PROCEDURES:</b>  Maintenance Recommendations - 43-44-45000 Series . . . . . Maintenance Recommendations - 46-48-49000 Series . . . . .	  00-7 00-20
IV		<b>TROUBLE DIAGNOSIS:</b>	

### DIVISION I SPECIFICATIONS AND ADJUSTMENTS

#### 00-7 LUBRICATION CHARTS—1966 BUICK—ALL SERIES

Refer to pages 00-8 through 00-12 for Lubrication Charts.

### DIVISION III

#### SERVICE PROCEDURES

##### 00-8 MAINTENANCE RECOMMENDATIONS 43-44-45000 SERIES

###### a. Engine Oil

Engine crankcase oils have a definite effect on ease of starting, oil economy, combustion chamber

deposits and engine wear. It is recommended that you use an oil which, according to the label on the can, is: (1) intended for service MS and (2) passes car makers' tests or meets General Motors Standard GM 4745-M. Oils conforming to these types contain detergent additives.

###### b. Grade or Viscosity

The grade or viscosity (SAE number) of engine oil should be selected for the lowest anticipated

temperature at which cold engine starting will be required as recommended in the temperature-viscosity chart on page 00-13.

Oil level should be checked more frequently during the break-in period since somewhat higher oil consumption is normal until piston rings become seated.

The oil level should be maintained between the "operating range" marks on the gauge rod; each space between marks represents one quart. Do not fill above the upper mark.

### 1966 43-44000 SPECIAL-SKYLARK LUBRICATION CHART

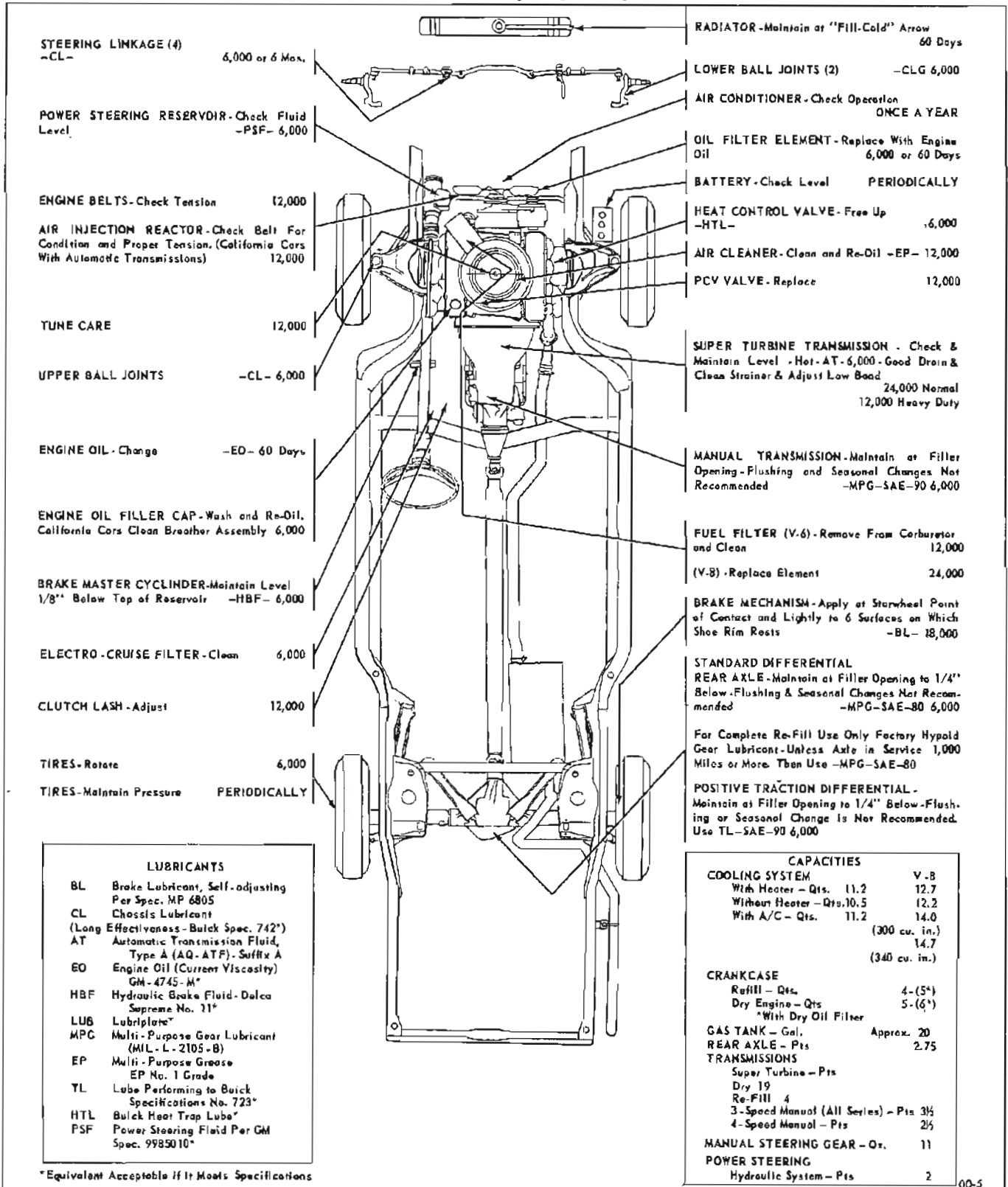

LUBRICANTS	
BL	Brake Lubricant, Self-adjusting Per Spec. MP 6805
CL	Chassis Lubricant
(Long Effectiveness - Buick Spec. 742*)	
AT	Automatic Transmission Fluid, Type A (A.Q. ATF) - Suffix A
EO	Engine Oil (Current Viscosity) GM-4745-M*
HBF	Hydraulic Brake Fluid - Dacia Supreme No. 71*
LUB	Lubriplate™
MPC	Multi-Purpose Gear Lubricant (MIL-L-2105-B)
EP	Multi-Purpose Grease EP No. 1 Grade
TL	Lube Performing to Buick Specifications No. 723*
HTL	Buick Heat Trap Lube™
PSF	Power Steering Fluid Per GM Spec. 9985010*

\*Equivalent Acceptable if it Meets Specifications

CAPACITIES	
<b>COOLING SYSTEM</b>	V-8
With Heater - Qts.	11.2 12.7
Without Heater - Qts.	10.5 12.2
With A/C - Qts.	11.2 14.0
	(300 cu. in.)
	14.7
	(340 cu. in.)
<b>CRANKCASE</b>	
Refill - Qts.	4-(5*)
Dry Engine - Qts.	5-(6*)
*With Dry Oil Filter	
<b>GAS TANK</b> - Gal.	Approx. 20
<b>REAR AXLE</b> - Pts	2.75
<b>TRANSMISSIONS</b>	
Super Turbine - Pts	
Dry 19	
Re-Fill 4	
3-Speed Manual (All Series) - Pts	3½
4-Speed Manual - Pts	2½
<b>MANUAL STEERING GEAR</b> - Oz.	11
<b>POWER STEERING</b>	
Hydraulic System - Pts	2

Figure 00-5—Lubrication Chart - 43000 & 44000 Series

## 1966 44600 SKYLARK GRAN SPORT LUBRICATION CHART

**ENGINE BELTS**-Check Tension 12,000

**AIR INJECTION REACTOR**-Check Belt for Condition and Proper Tension 12,000

**STEERING LINKAGE (4)**  
-CL- 6,000 or 6 mas.

**POWER STEER. RESERVOIR** Check Oil Level Hot -PSF- 6,000

**TIRES**-Rotate 6,000  
Maintain Pressure PERIODICALLY

**ENGINE**-Check Oil Level Change -EP- PERIODICALLY 60 Days

**TUNE CARE** 12,000

**UPPER STEERING KNUCKLE BALL JOINTS (2)**  
-CL- 6,000 or 6 mas.

**STD. STEERING GEAR**-MPG- Check Level 24,000

**FILLER CAP**-Wash and Re-oil Elements -EO- California Curs Clean Breather Assembly 6,000

**BRAKE MASTER CYLINDER**-Maintain Level 1/8" Below Top of Reservoir -HBF- 6,000

**ELECTRO. CRUISE FILTER**-Clean 6,000

**POSITIVE TRACTION DIFFERENTIAL**  
Maintain at Filler Opening to 1/4" Below. Flushing & Seasonal Changes Not Recommended  
Use TL-SAE-90  
Other Lubes May Cause Damage -TL- 6,000

**RADIATOR**-Maintain Coolant at "Fill Cold" Arrow PERIODICALLY

**LOWER STEERING KNUCKLE BALL JOINTS (2)**  
-CL- 6,000 or 6 mas.

**AIR CONDITIONER**-Check Operation ONCE A YEAR

**OIL FILTER RECOMMENDATION**  
Replace at Oil Change Nearest to 6,000 Miles or 6 Mos. Whichever Occurs First

**BATTERY**-Check Level PERIODICALLY

**HEAT CONTROL VALVE**-Free Up -HTL- 6,000

**AIR CLEANER**-Replace Paper Element 12,000

**POSITIVE CRANKCASE VENTILATOR**-Replace with Correctly Calibrated Valve 12,000

**SUPER TURBINE TRANSMISSION**-Check & Maintain Level-Hot-AT- 6,000  
Clean Pan, Refill, and Adjust Low Band 24,000 Normal  
12,000 Heavy Duty

**FUEL FILTER (V.B)**  
Replacement of Element Recommended 24,000

**MANUAL TRANSMISSION** -Maintain at Filler Opening-Flushing & Seasonal Changes Not Recommended-SAE-90 6,000

**BRAKE MECHANISM**-Apply at Star Wheel Point of Contact and Lightly to 6 Surfaces on Which Shoe Rim Rests -BL- 18,000

**STANDARD DIFFERENTIAL**  
**REAR AXLE**-Maintain at Filler Opening to 1/4" below-Flushing & Seasonal Changes Not Recommended-MPG- SAE-89 6,000  
For Complete Refill Use Only Factory Hypoid Gear Lubricant-Unless Axle in Service 1000 Miles or More. Then Use -MPG-SAE-80

**LUBRICANTS**

**BL** = Brake Lubricant, Self-adjusting Per Spec. MP 6805

**CL** = Chassis Lubricant (Long Effectiveness - Buick Spec. 742\*)

**AT** = Automatic Transmission Fluid, Type A (AQ-ATF)-Suffix A

**EO** = Engine Oil (Current Viscosity) .GM. 4745-M\*

**HBF** = Hydraulic Brake Fluid-Delco Supreme No. 11\*

**LUB** = Lubriplate\*

**MPG** = Multi-Purpose Gear Lubricant (MIL-L-2105-B)

**EP** = Multi-Purpose Grease EP No. 1 Grade

**TL** = Lube Performing To Buick Specifications No. 723\*

**HTL** = Buick Heat Trap Lube\*

**PSF** = Power Steering Fluid Per GM Spec 9985010\*

**CAPACITIES**

**Cooling System**  
With Heater-Qts. . . . . 18.5  
Without Heater-Qts. . . . . 17.5  
With A/C - Qts. . . . . 18.5

**Crankcase**  
Refill-Qts. . . . . 4 (5\*)  
Dry Engine-Qts. . . . . 5 (6\*)  
\*With Dry Oil Filter

**Gas Tank**-Gal. . . . . Approx. 20  
**Rear Axle**-Pts. . . . . 2.75

**Transmission** -See Refill Procedure, Paragraph 71-8.  
**SUPER TURBINE**  
3 Speed Manual -Pts. . . . . 3 1/2  
4 - Speed Manual Pts . . . . . 2 1/2  
**Manual Steering Gear**-Oz. . . . . 11  
**Power Steering**  
Hydraulic System-Pts. . . . . 2

\* EQUIVALENT ACCEPTABLE IF MEETING SPECIFICATIONS

Figure 00-6—Lubrication Chart - 44600 Skylark Gran Sport

# 1966 45000 LE SABRE LUBRICATION CHART

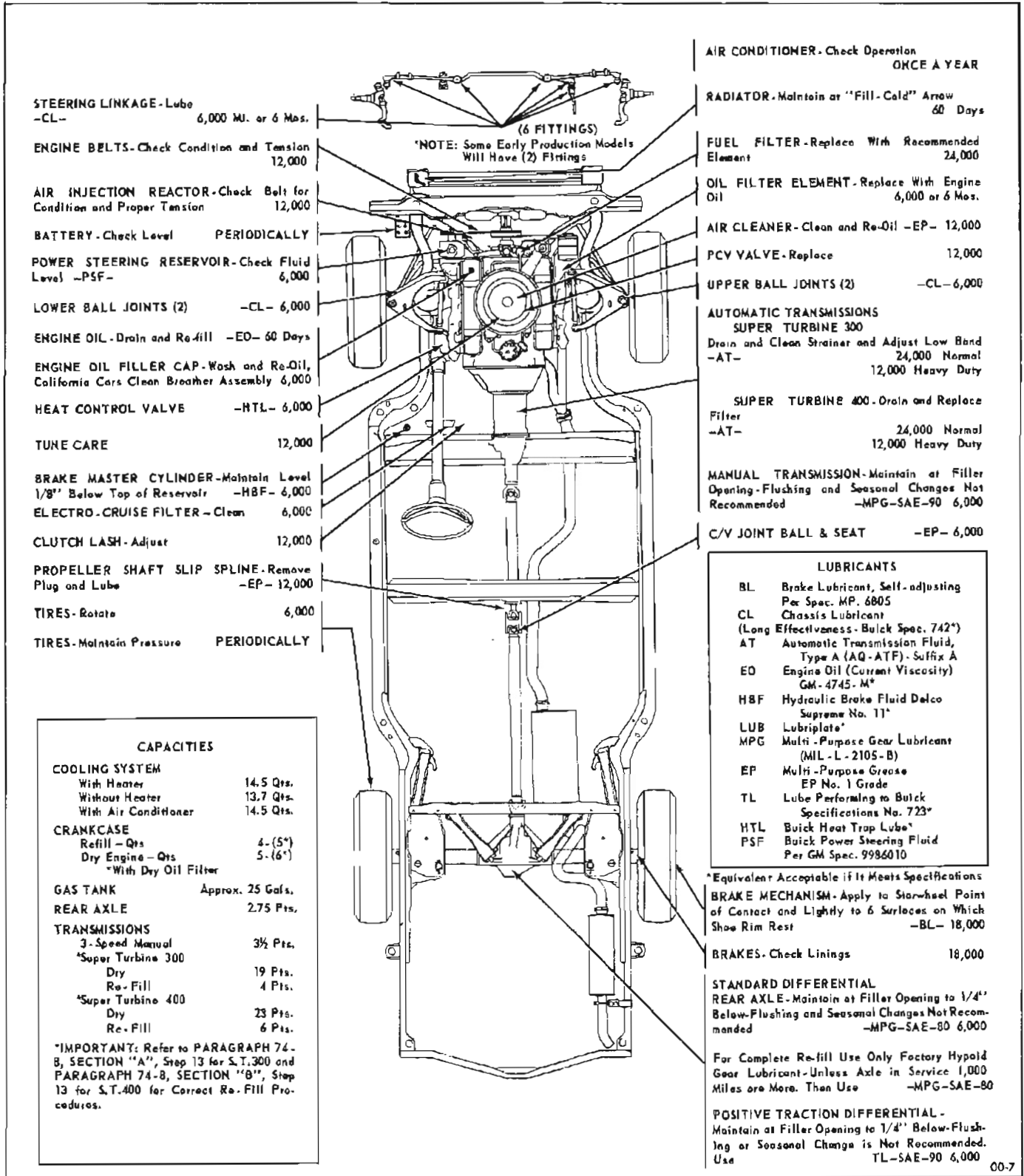

Figure 00-7—Lubrication Chart - 45000 Series

## 1966 46-48000 WILDCAT - ELECTRA 225 LUBRICATION CHART

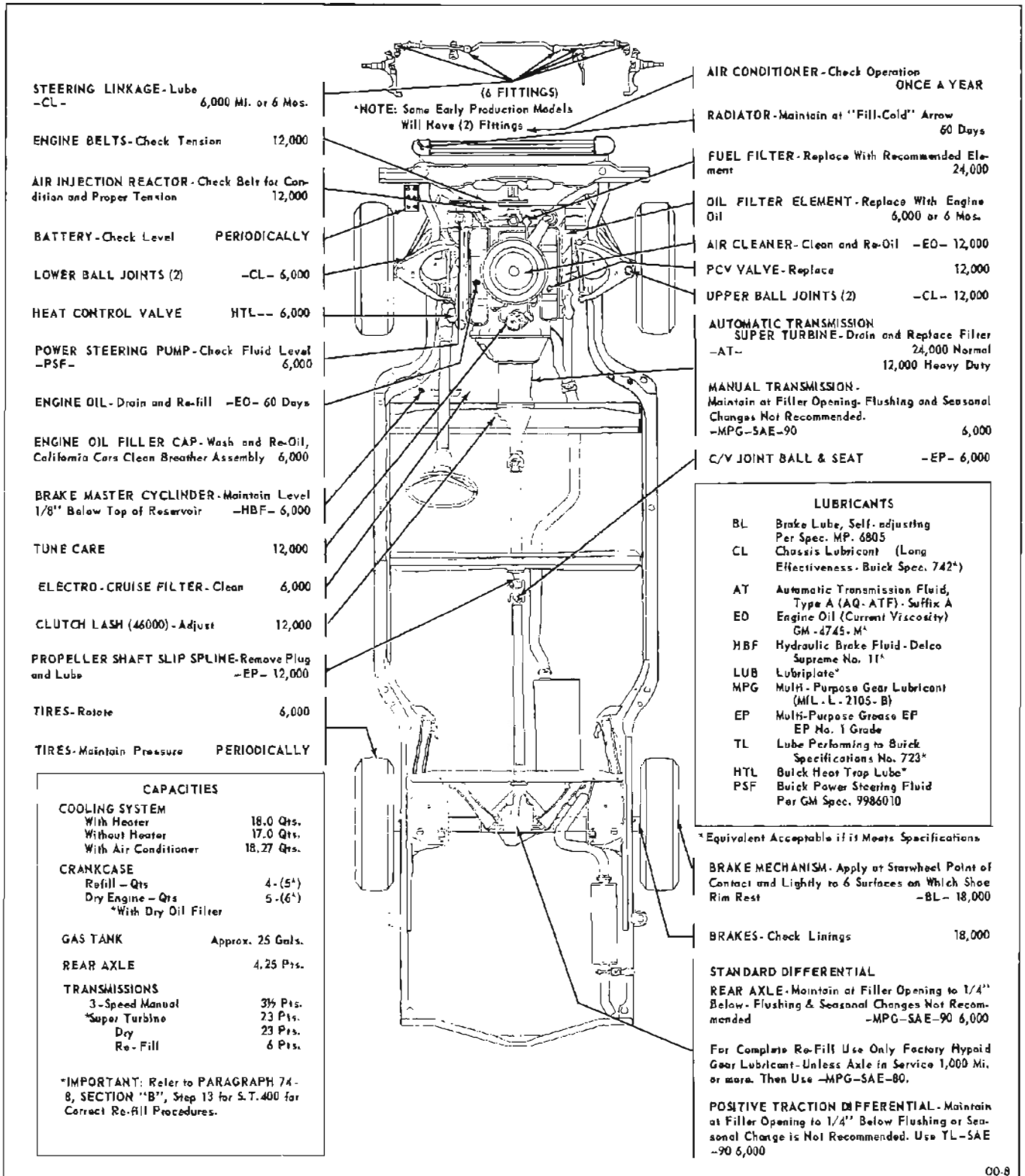

Figure 00-8—Lubrication Chart - 46-48000 Series

## 1966 49000 RIVIERA LUBRICATION CHART

STEERING LINKAGE - Lube -CL-	6,000 Mi. or 6 Mos.
BATTERY - Check Level	PERIODICALLY
ENGINE BELTS - Check Tension	12,000
AIR INJECTION REACTOR - Check Belt for Con- dition and Proper Tension	12,000
POWER STEERING RESERVOIR - Check Fluid Level	-PSF- 6,000
ENGINE OIL FILLER CAP - Wash and Re-Oil, California Cars Clean Breather Assembly	6,000
ENGINE OIL - Drain and Re-Fill	-EO- 60 Days
BRAKE MASTER CYLINDER - Maintain Level 1/8" Below Top of Reservoir	-HBF- 6,000
ELECTRO - CRUISE FILTER - Clean	6,000
AIR CLEANER - Clean and Re-Oil. Gran Sport Model - Replace	12,000
TUNE CARE	12,000



\*NOTE: Some Early Production Models  
Will Have (2) Fittings

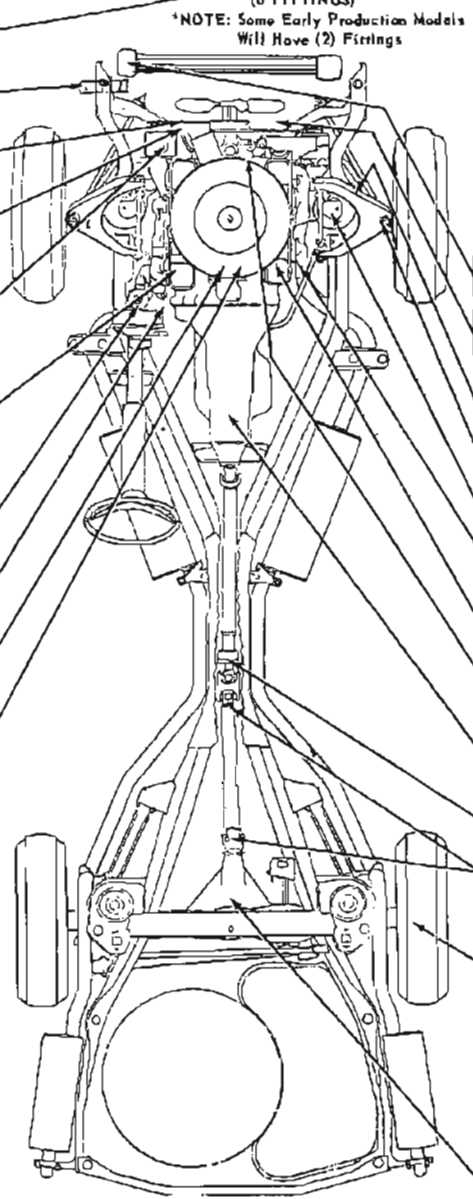

LUBRICANTS	
CL	Chassis Lubricant (Long Effectiveness - Buick Spec. 742*)
AT	Automatic Transmission Fluid, Type A (Having AQ-ATF and identification number, Suffix A embossed on lid of container)
EO	Engine Oil (Current Viscosity) GM-4745-M*
HTL	Buick Heat Trap Lube*
HBF	Hydraulic Brake Fluid - Dolex Super No. 11*
LUB	Lubriplate
MPG	Multi-Purpose Gear Lubricant (MIL-L-2105-B)
TL	Lube Conforming to Buick Specification No. 723*
EP	Multi-Purpose Grease EP No. 1 Grade
PSF	Buick Power Steering Gear Liquid or Equivalent Meeting GM Spec. 9986610

\*Equivalent Acceptable if it Meets Specifications  
RADIATOR - Maintain at "Fill-Cold" Arrow  
60 Days

AIR CONDITIONER - Check Operation	ONCE A YEAR
LOWER BALL JOINTS (2)	-CL- 6,000
UPPER BALL JOINTS (2)	-CL- 6,000
OIL FILTER ELEMENT - Replace With Engine Oil	6,000 or 6 Mos.
HEAT CONTROL VALVE - Free UP	-HTL- 6,000
PCV VALVE - Replace	12,000
FUEL FILTER - Replace With Recommended Ele- ment	24,000
<b>AUTOMATIC TRANSMISSIONS</b>	
SUPER TURBINE - Drain and Replace Filter	24,000 Normal
-AT-	12,000 Heavy Duty
PROPELLER SHAFT SLIP SPLINE - Remove Plug and Lube	-EP- 12,000
C/V JOINT BALL & SEAT	-EP- 6,000
BRAKES - Check Linings	18,000
BRAKE MECHANISM - Apply at Starwheel Point of Contact and Light to 6 Surfaces on which Shoe Rim Rest	-BL- 18,000
<b>STANDARD DIFFERENTIAL</b>	
REAR AXLE - Maintain at Filler Opening to 1/4" Below - Flushing & Seasonal Changes Not Rec- ommended	-MPG-SAE-80 6,000

CAPACITIES	
<b>COOLING SYSTEM</b>	
With Heater	18.0 Qts.
Without Heater	17.0 Qts.
With Air Conditioner	18.3 Qts.
<b>CRANKCASE</b>	
Refill - Qts.	4 - (5*)
Dry Engine - Qts.	5 - (6*)
* With Dry Oil Filter	
GAS TANK	Approx. 22 Gals.
REAR AXLE	4.25 Pts.
<b>*SUPER TURBINE TRANSMISSION</b>	
Dry	23 Pts.
Re-Fill	6 Pts.
*IMPORTANT: Refer to PARAGRAPH 74- 8, SECTION "B", Step 13 for S.T. 400 for Correct Re-Fill Procedures.	

For Complete Re-Fill Use Only Factory Hypoid  
Gear Lubricant - Unless Axle in Service 1,000 Mi.  
or More. Then Use -MPG-SAE-80

POSITIVE TRACTION DIFFERENTIAL - Maintain  
at Filler Opening to 1/4" Below Flushing or Sea-  
sonal Change is Not Recommended. Use TL-SAE  
-90 6,000

Figure 00-9-Lubrication Chart - 49000 Series

c. Engine Oil Change and Viscosity Recommendations

Anticipated Lowest Temperatures	Use S A E Viscosity Number	Change Your Oil at Least
Above Freezing (+32°F.)	S A E 10W-30 S A E 20W	Every 60 days*
Below Freezing (+32°F. to 0°F.)	S A E 10W S A E 10W-30	Every 60 days*
Below 0°F.	S A E 5W-20 S A E 5W	Every 60 days*

\*Never exceed 6,000 miles between oil changes. During extreme driving conditions which produce oil contamination by dust, water, or other foreign material, the oil should be changed more frequently than every 60 days. Your authorized Buick dealer is well qualified to advise you.

d. Oil Color

The color of "Service MS" type oil does not indicate its condition since it normally becomes dark (black or gray) after only a few hundred miles of driving. This is because the detergent content envelopes and holds in suspension extremely fine but harmless soot (soft carbon) and lead particles. The oil filter element does not remove this harmless material but it does remove harmful particles such as road dust, metal chips and hard carbon.

e. Crankcase Flushing

Flushing the crankcase with oils or solutions other than a good grade of 10-W engine oil is not recommended. When flushing to remove contamination appears advisable, use 3 quarts 10-W oil (4 quarts if filter is drained) and idle the engine at 1000 RPM (equivalent to 20 MPH) until the oil is hot, then drain crankcase and oil filter immediately after stopping engine. Fill crankcase with correct quantity and seasonal grade of oil. Install new oil filter element.

f. Use of Buick HD Concentrate

Buick HD Concentrate, available through Buick Parts Department

under Group 1.850 is a compound of the materials used by oil refiners to manufacture high detergent motor oils. It is intended for use in engines operating under aggravated conditions where engine deposits, rust and corrosion cannot be adequately retarded by motor oils readily available to the average motorist. It is especially recommended for engines operated under restricted conditions such as frequent stops, short trips and slow speeds where such symptoms as sticking valves, valve lifters and rings are noticed.

Although HD Concentrate may be used continually, it is normally unnecessary to use it with every crankcase refill. When used, the instructions on the container should be carefully observed.

g. Periodically While Vehicle is Being Refueled

1. Battery - Check Level.

If necessary, add colorless, odorless drinking water to bring level to split ring at bottom of filler wells.

**NOTE:** Do not overfill. Clean top of battery; if wet with acid, neutralize with soda and wash clean. See Figure 00-10.

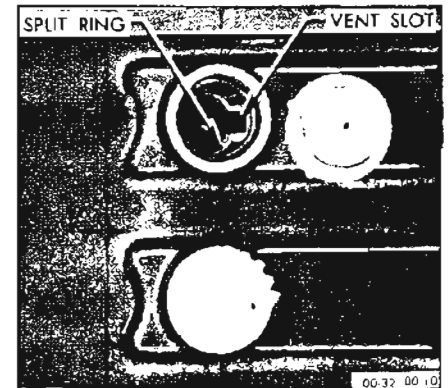

Figure 00-10—Battery Filler Well

2. Tires

For maximum tire life with corresponding good ride characteristics, maintain the tire pressure recommended in Group 100.

3. Oil Filler Cap

Check periodically for signs of dirt and other accumulations in filter portion of cap. Clean as often as necessary. This can be done by quickly washing in a suitable solvent and dipping in engine oil.

4. Radiator Coolant

Radiator coolant level should be checked when the engine is cold if at all possible. If the radiator cap is removed when the system is at normal operating temperature, the coolant will boil and spurt out due to the release of pressure. Coolant lost in this manner must, of course, be replaced. If coolant should be needed, fill radiator to tip of "Fill Cold" arrow stamped on inside of filler neck. Do not overfill as loss of coolant due to expansion will result.

5. Engine Oil

This check should be performed last to allow the oil to drain back into the pan. Adding oil between changes may be necessary if the level is below the lower mark on the dip stick. See Figure 00-11.

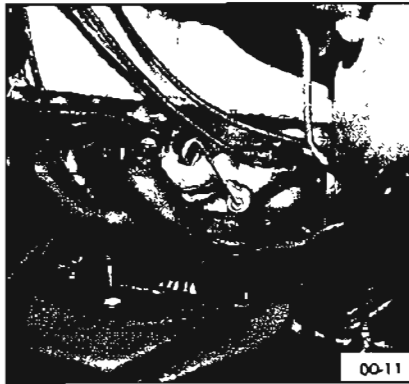

Figure 00-11—Engine Oil Gauge Rod

**NOTE:** Oil level should only be checked when the engine is warm, as cold oil drains back to the oil pan very slowly.

#### h. Maintenance—Every 6,000 Miles

##### 1. Engine Oil Change Recommendations

Drain and refill engine crankcase every 60 days; however, never exceed 6,000 miles between changes. See subparagraph a, b, and c for oil recommendations.

##### 2. Engine Oil Filter Change Recommendations

Replace engine oil filter with the engine oil change which comes nearest to 6,000 miles or 6 months--whichever occurs first.

To change, screw filter off the filter base and discard. Wipe the gasket area of the base clean and install a new gasket in the groove of a new AC Type PF-10 filter or equivalent. Lubricate the gasket and screw the filter on the nipple until the gasket just touches the base; tighten filter 2/3 more. Start engine. Do not accelerate engine beyond the normal idle until oil pressure light goes out. Check the filter area for leaks after the engine has run for five (5) minutes. See Figure 00-12.



Figure 00-12—Oil Filter Installation

##### 3. Oil Filler Cap

Wash cap thoroughly in a suitable solvent and dry. Dip in engine oil and allow to drain while performing other services. Prior to installation, re-oil and install on cover.

##### 4. Front Suspension and Steering Linkage

The Buick front suspension and steering linkage has been lubricated with a long-effectiveness lubricant at the factory and should be re-lubricated with a long-effectiveness lubricant equivalent to General Motors Specification 9985024 every 6,000 miles or six months whichever occurs first.

**NOTE:** If lubricants not intended for long-effectiveness application are used, the lubrication interval should be shortened and should not exceed 2,000 miles.

Wipe dirt from the lubrication fittings and apply at lubrication fittings under pressure at the following points:

Upper Ball Joints (2 fittings)  
Lower Ball Joints (2 fittings)  
Steering Linkage (4 fittings)

##### 5. Manifold Heat Valve

Place a few drops of "Buick Heat Trap Lube" or equivalent on shaft

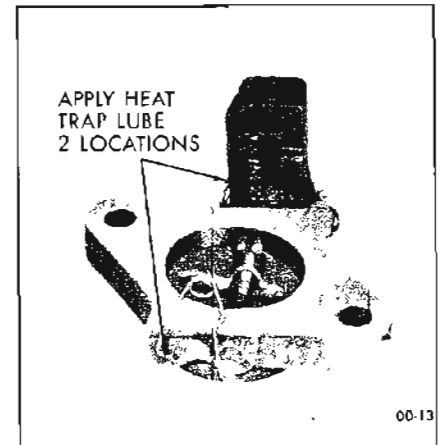

Figure 00-13—Lubricating Points on Manifold Heat Control Valve

at each end, and free up if necessary. This can be found in the Buick Parts Book under Group 8,800, Part 1050009. See Figure 00-13.

##### 6. Check Fluid Level

**Master Brake Cylinder** - Maintain fluid level 1/8" below top of filler opening. When adding brake fluid, use only Delco Supreme #11 hydraulic brake fluid or equivalent. Never use reclaimed fluid, mineral oil or fluid inferior to SAE Standard 70-R-1.

**Manual Transmission** - Check oil level, after allowing time for oil to settle. Clean the surrounding area before removing filler plug. Level should be maintained at filler plug opening by adding SAE 90 multi-purpose gear lubricant.

**NOTE:** Draining and flushing transmission are not necessary unless the lubricant has become contaminated.

**Automatic Transmission** - Check transmission oil level with transmission oil at operating temperature (180° approximate), transmission in park, and engine idling.

Remove gauge rod located under right side of hood. See Figure 00-14. Wipe dry with clean cloth;

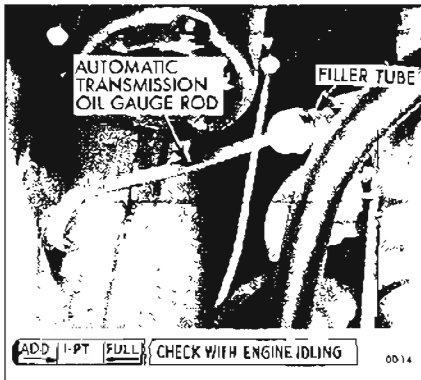

Figure 00-14—Automatic Transmission Oil Gauge Rod

then reinstall to full depth. Remove rod and note oil level.

If oil level is below the "ADD" mark on gauge rod, add oil specified under "every 24,000 miles" but do not fill above the "FULL" mark. Distance between the "FULL" and "ADD" marks represent approximately one pint.

**Power Steering Gear** - Thoroughly clean dirt from reservoir cap on top of oil pump; then remove cap. Fill within 1" of top of neck. Use only Buick Power Steering Fluid or equivalent meeting GM Specification 9985010.

**Rear Axle** - Check lubricant level after allowing time for lube to settle. Clean the surrounding area before removing filler plug. Level

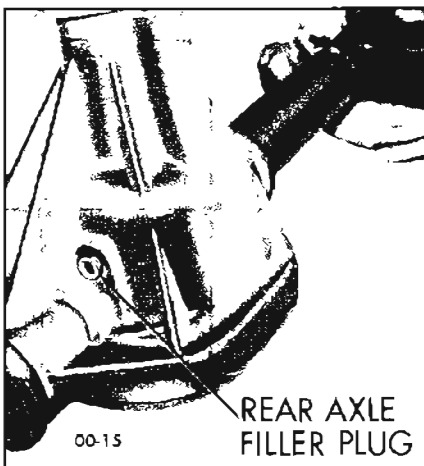

Figure 00-15—Rear Axle Filler Plug

should be maintained at filler plug opening to 1/4" below by adding SAE 90 Multi-Purpose Gear Lubricant (MIL-L-2105-B). See Figure 00-15. When car is operated in temperatures continuously below -10°F., use SAE 80 Multi-Purpose Gear Lubricant.

**NOTE:** Draining and flushing are not recommended unless the lubricant has become contaminated. When complete refilling is necessary, SAE 80 for standard or Positive Traction Multi-Purpose Gear Lubricant may be used, provided the axle has been in service for 1,000 miles or more. Axles with less than 1,000 miles must not be completely refilled with any lubricant other than Factory Hypoid Lubricant.

**Positive Traction Differential Rear Axle** - Identified by embossed tag attached to the axle cover lower bolt stating "Use limited slip differential lube only." Check lubrication level after allowing time for lubricant to settle. Clean the surrounding area before removing filler plug. Level should be maintained at filler plug opening to 1/4" below by adding lubricant conforming to Buick Specification #723. See Figure 00-16.

**NOTE:** If Positive Traction Differential lube becomes con-

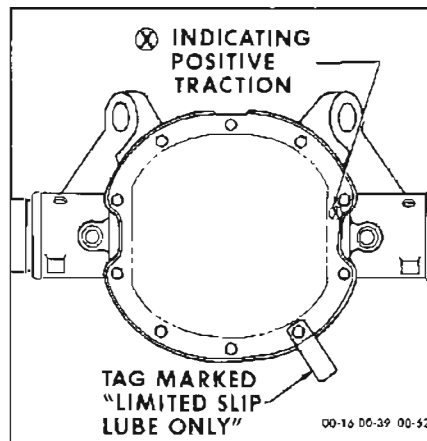

Figure 00-16—Positive Traction Identification

taminated, the axle assembly may be flushed with light engine oil and then refilled with Positive Traction lube.

**Minor Lubrication** - Occasionally lubricate the pivot points of moving parts such as door and hood hinges and latches, door hold open, clutch, transmission, parking brake and folding top linkages with Lubriplate, or equivalent, or engine oil where applicable. A small quantity of lock lubricant occasionally applied to lock cylinders will prevent sticking.

**NOTE:** Do not lubricate carburetor or throttle linkage.

7. Body Rubber Parts

Door, hood, and rear compartment rubber weatherstrips and bumpers may be kept pliable and quiet by the application of a light coat of Buick 4-X Compound or suitable silicone lubricant equivalent.

8. Tires

For best tire mileage, switch tires as recommended in Figure 00-17.

9. Clutch Lash

Should be adjusted every 6,000 miles.

i. Maintenance—Every 12,000 Miles or Once a Year

(Suggested in addition to the 6,000 mile recommendation)

1. Tune-Care

Tune-Care includes: clean and/or

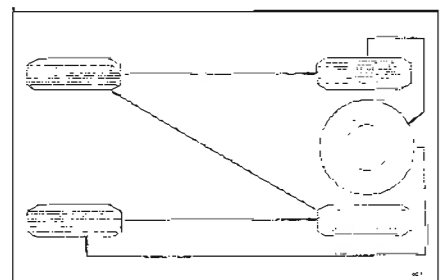

Figure 00-17—Tire Rotation Method

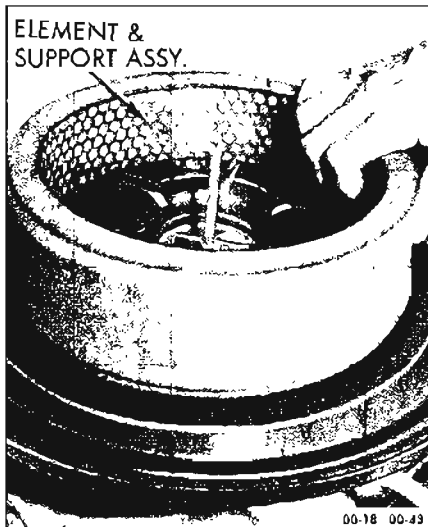

Figure 00-18—Air Cleaner Element and Support

replace spark plugs and ignition points, check compression, battery, cranking system, charging system, fuel pump, choke, hose connections, belts, carburetor, adjust engine timing and idle speed.

## 2. Air Cleaner

It is recommended that the air cleaner be serviced every 12,000 miles. If car is operated in dusty territory, check condition of air cleaner element more frequently and clean if dirty.

To clean, carefully remove the element from the mesh support, wash in kerosene and squeeze out.

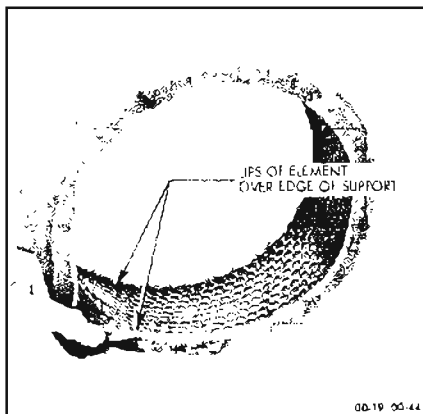

Figure 00-19—Installing Element on Support

**CAUTION:** Take precautions against the possibility of fire. Do not wring the element or it may be torn. Wrap the element in a dry cloth and squeeze to remove all possible solvent.

Oil the element liberally with engine oil and squeeze to evenly distribute the oil through the element and remove excess.

**NOTE:** The element should be only damp with oil not dripping.

Reinstall the element on mesh support, taking care to have edges of the element over the support to effect a good seal. See Figure 00-19. Clean any oil or accumulated dirt out of air cleaner housing before installing element. If the element becomes damaged, replace with AC-type A 96C or equivalent on V-8 engines, AC-type A 132C or equivalent on V-6 engines, and AC-type A 85C or equivalent on Skylark Gran Sport.

## 3. Fuel Filter (V-6 Engine)

Remove from carburetor fuel inlet, inspect, clean, or replace if necessary. More frequent servicing may be necessary if contaminants have entered the fuel system.

## 4. Belts

Inspect engine driven belts for cracks and proper tension.

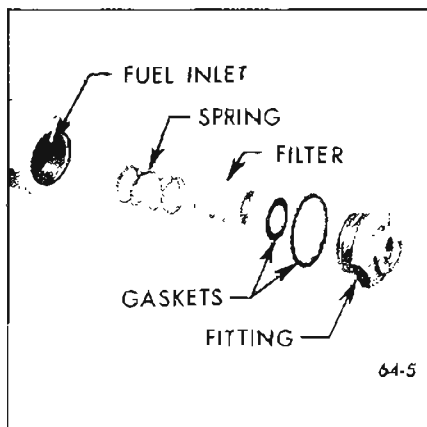

Figure 00-20—V-6 Engine Carburetor Fuel Filter

## 5. Wheel Alignment and Balance

## 6. Super Turbine 300 & 400

If transmission is subjected to heavy duty usage, the transmission recommendations listed under "24,000 Miles" should be performed at 12,000 miles.

## 7. Positive Crankcase Ventilator Valve

Replace positive crankcase ventilation valve with a correctly calibrated valve such as AC-type CV-683 or equivalent for V-8 engines, or AC-type CV-684 or equivalent for V-6 engines.

Inspect P.C.V. system hoses for leaks and possible obstructions. Make certain all connections are tight. Replace any defective parts if necessary.

On California cars, the breather assembly should be inspected and cleaned. On standard P.C.V. equipped cars, the normal oil filter cap maintenance recommendations specified at 6,000 miles should be performed.

## j. Maintenance—Every 18,000 Miles

(Suggested in addition to the normal 6,000 mile recommendations).

## 1. Brakes

Examine brake linings for wear and the self-adjusting mechanism for proper functioning. Although linings may not be excessively worn, this check will indicate when another inspection should be made. If required, use Buick Factory Engineering replacement linings or equivalent. Lubricate the self-adjusting mechanism adjusting screw with Delco Moraine Special Brake Lubricant or equivalent.

## 2. Front Wheel Bearings

There is no periodic lubrication schedule for front wheel bearings.

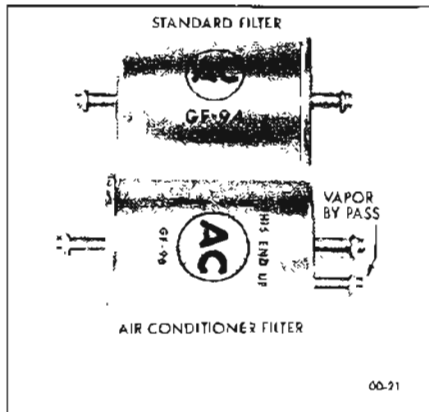

Figure 00-21—Fuel Filters (V-8 Engines)

They may be relubricated whenever brake drums are removed. Always follow with the correct bearing adjustment as outlined in GROUP 30.

k. Maintenance—Every 24,000 Miles

(Suggested in addition to the 8,000 and 12,000 mile recommendations.)

1. Fuel Filter (Exc. V-8's)

Replacement of the disposable filter is recommended. More frequent replacement may be necessary if contaminants have entered the fuel system. Replace with filter type GF-94 or equivalent on non-air conditioned cars and type GF-415 or equivalent for air conditioned cars.

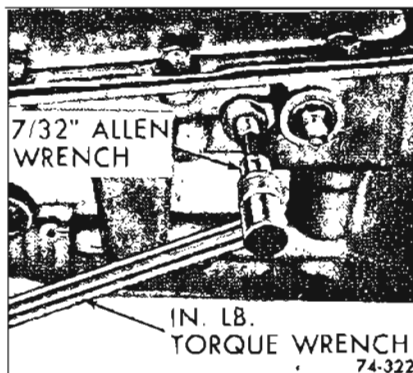

Figure 00-22—Tightening Low Band Screw

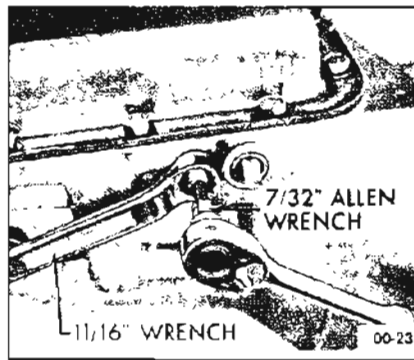

Figure 00-23—Backing Off Low Band Screw

2. Automatic Transmissions

At this interval, the automatic transmission should be drained, the oil pan and strainer cleaned, new oil added, and the low band adjusted on Super Turbine 300 models.

APPROVED OIL FOR BUICK AUTOMATIC TRANSMISSIONS - The following oils are approved for Buick Automatic Transmissions and no other fluid should be used:

Special Buick Oil - available through Buick Warehouses under Group 4.101. Automatic Transmission Fluid Type A - use only Automatic Transmission Fluid identified by the mark "AQ-ATF" followed by a number and the Suffix A. (AQ-ATF-XXXX-A).

CLEANING OIL PAN AND STRAINER - When performing

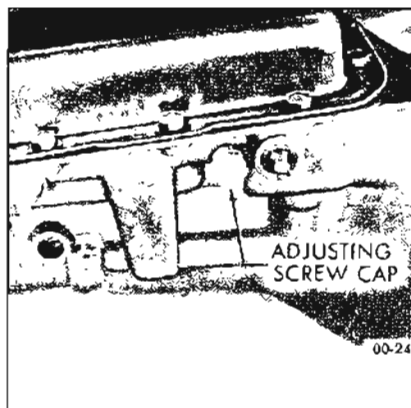

Figure 00-24—Installing Adjuster Screw Cap

this operation, carefully inspect the "O" ring seal on the end of the strainer. If damaged or worn, replace with new "O" ring seal. Upon reassembling, take care not to cut or tear the "O" ring located near the end of the pipe. If it is damaged in any way it must be replaced with a new one.

LOW BAND ADJUSTMENT Super Turbine "300" only

1. Adjust low band adjusting screw to 40 in. lbs. See Figure 00-22.
2. Back off adjusting screw four (4) turns and lock nut. See Figure 00-23.
3. Replace adjusting screw cap. Refer to Figure 00-24.

3. Manual Steering Gear

At this interval, the manual steering gear lubricant level should be checked. Remove the bolt on gear cover marked "Lube." Add chassis lubricant conforming to GM Specification 9985024 as necessary.

l. Maintenance—Seasonal (Cooling System and Air Conditioner Services)

1. Anti-Freeze

A permanent glycol type corrosion and anti-freeze cooling system protection solution developed for year around use (General Motors Specification, GM 1899-M) has been installed in the cooling system of the vehicle at the factory.

Although this type coolant should be used continuously throughout the year, once every two years the cooling system should be drained, flushed and permanent type anti-freeze also conforming to General Motors Specification GM 1899-M installed. Water alone, Methanol, or alcohol type anti-freeze is definitely not recommended.

If water alone must be used as coolant in an emergency, it is extremely important that Buick Heavy Duty Cooling System Protector and Water Pump Lubricant be added to the cooling system as soon as possible. This material is supplied under Buick Part 1050238. If any other cooling system protector is used, be sure it is labeled to indicate that it meets General Motors Specification GM 1894-M.

2. Air Conditioner-Equipped Models

It is recommended that the air conditioner be operated for a few minutes every two weeks regardless of the season. This practice will keep the internal parts of the compressor lubricated. In addition, the system should be functionally checked by the dealer each spring in preparation for summer operation.

Keep insects and dirt from accumulating on the air conditioner condenser.

m. Maintenance—As Required

1. Body Lubrication

The movable mechanical parts of the body are lubricated at the factory to insure proper and quiet

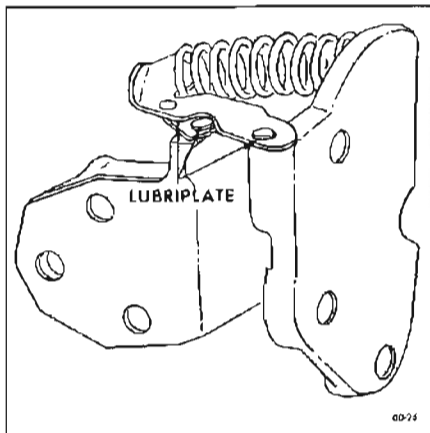

Figure 00-25—Door Hold Open Lubrication

operation. If additional lubrication is required, the following specified materials should be used at the locations listed.

Front and Rear Door Hinge Hold Open - Wipe off dirt and apply a thin coat of Lubriplate or equivalent at points indicated in Figure 00-25.

Instrument Panel Compartment Door Hinge - Wipe off dirt and apply a sparing amount of dripless oil to the hinge frictional points. Operate door and wipe off excess lubricant.

Lock Cylinders - If key operates roughly in any lock cylinder, blow powdered graphite into key slot. DO NOT USE OIL.

Gas Tank Filler Door - Apply a few drops of light engine oil to hinge. Wiper off excess oil to prevent accumulation of dirt.

Door Lock Fork Bolt - Wipe off dirt and apply a thin coat of stick type lubricant to contact point as shown in Figure 00-26.

Rear Compartment Lid Lock - Apply a thin coat of Lubriplate

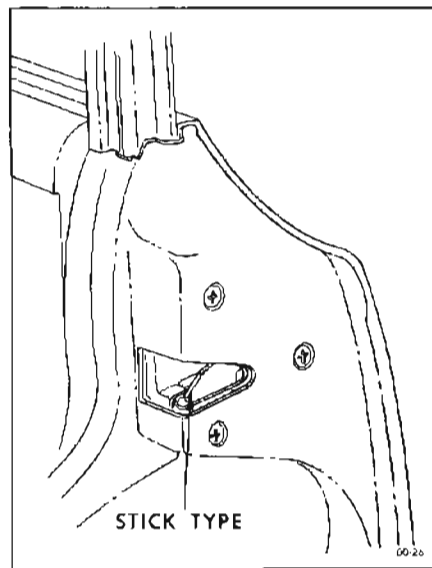

Figure 00-26—Door Lock Fork Bolt Lubrication

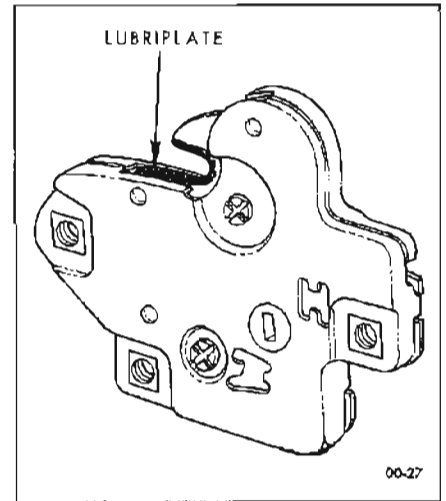

Figure 00-27—Rear Compartment Lid Lock Bolt Lubrication

or equivalent to striker bolt as shown in Figure 00-27.

Door Jam Switch - Wipe off dirt and apply a thin coat of Lubriplate or equivalent to end surface of switch plunger and remove excess lubricant.

Front Seat Adjuster Tracks - A thin coat of Lubriplate or equivalent should be applied to seat tracks.

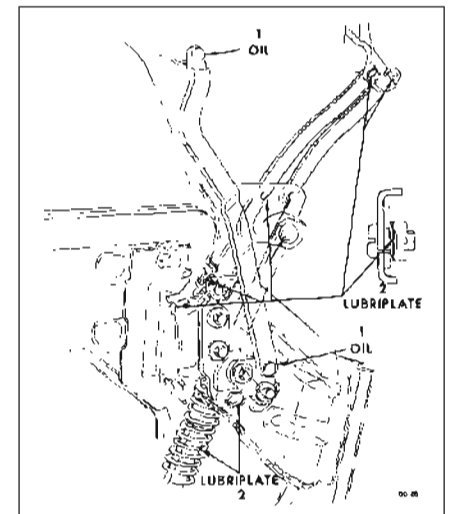

Figure 00-28—Convertible Top Linkage Lubrication

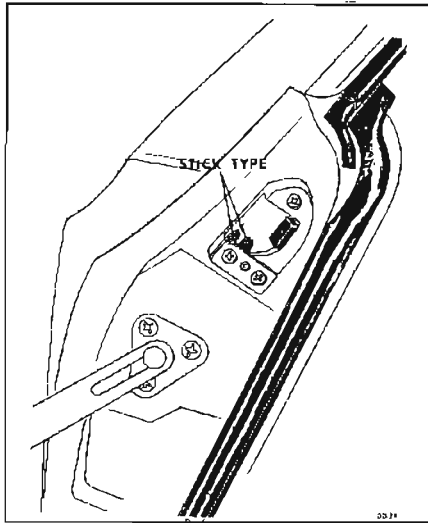

Figure 00-29—Tail Gate Lock Striker Lubrication

Convertible Top Mechanism - Apply a sparing amount of dripless oil to points indicated by "1" and Lubriplate or equivalent to those points indicated by "2" in Figure 00-28.

Station Wagon Folding Seat Linkage - Apply a sparing amount of dripless oil to all frictional points. Work seat as required and wipe off excess lubricant.

Tail Gate Lock Striker - Apply a thin coat of stick type lubricant to surface of lock bolt striker teeth. After lubrication, close door

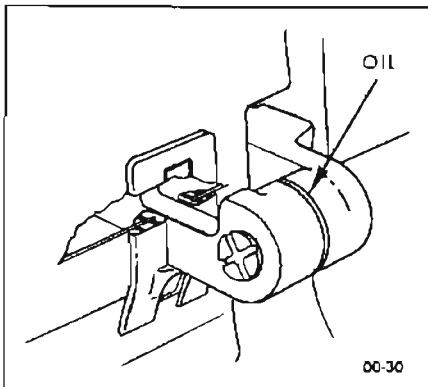

Figure 00-30—Tail Gate Hinge Lubrication

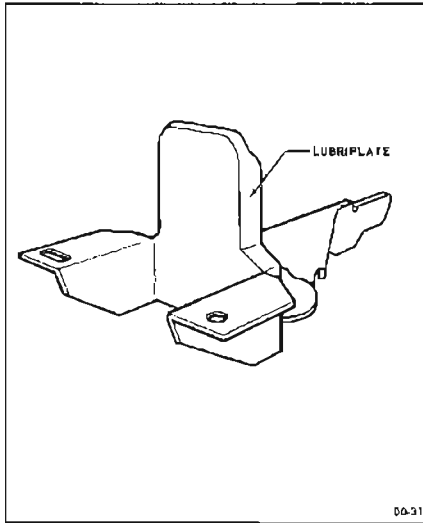

Figure 00-31—Hood Latch Lubrication

several times and remove excess lubricant. See Figure 00-29.

Tail Gate Hinges - Apply a sparing amount of dripless oil to frictional points of hinge. Work tail gate several times and remove excess lubricant. See Figure 00-30.

Folding Top Lift Cylinder Piston Rods - With folding top in raised position, wipe exposed portion of each top lift cylinder piston rod with a cloth dampened with brake fluid to remove any oxidation or accumulated grime. With another clean cloth, apply a light film of brake film to act as a lubricant.

**NOTE: DO NOT ALLOW BRAKE FLUID TO COME IN CONTACT WITH ANY PAINTED OR TRIMMED PARTS OF THE BODY.**

## 2. Chassis Lubrication

Hood Latch and Hinges - Apply Lubriplate to hood latch as shown in Figure 00-31. Apply engine oil to hood hinge pins.

Hood Lacing and Hood Bumpers - Lightly coat hood lacing and bumpers with silicone lube. Wipe off excess.

## n. Rear Axle Lubricant Recommendations

### 1. Standard Differential Axle

Buick Special and Skylark rear axles are filled at the factory with a special hypoid gear lubricant. It is not necessary to remove the original lubricant at any time except when it has become contaminated or when it is required for inspection of parts or for repairs. Therefore, there is no drain hole in the rear axle housing.

Draining and flushing are not recommended unless the lubricant has been contaminated. When complete refilling is necessary, Multi-Purpose Gear Lubricant (conforming to Specification MIL-L-2105B) may be used, provided the axle has been in service for 1,000 miles or more. Axles with less than 1,000 miles service must not be completely refilled with any lubricant other than Factory Hypoid Lubricant.

### 2. Positive Traction Differential Axle

Buick Positive Traction Differential Axles are filled at the Factory with a special lubricant conforming to Buick Specification No. 723. It is not necessary to remove the lubricant at any time except when it has become contaminated or when it is required for inspection of parts or for repairs. There is no drain hole in the rear axle housing.

When adding lubricant to a Positive Traction Rear Axle for any reason, use only those lubricants meeting Buick Specification 723. Lubricant conforming to this specification may be obtained from the Parts Department under Group 5.535.

Positive Traction Differential Rear Axles can be identified by an embossed tag which reads, "Use Limited Slip Differential Lube Only." It is secured to the

differential rear cover by one of the attaching bolts. See Figure 00-16.

**o. Vehicle Operation Under Dusty Conditions**

When cars are operated in dusty climates or under adverse conditions, the following precautions should be taken to prevent dirt and other foreign materials from entering the engine.

1. Change Engine Oil - Change more often than is recommended in subparagraph c. The severity of the conditions should determine the frequency of oil changes.
2. Oil Filter - Change each time that the oil is changed.
3. Oil Filler Cap - When dirt is found in cap, clean as directed in subparagraph h.
4. Air Cleaner Element - If dirt and foreign materials found on element are excessive, clean as directed in subparagraph i. Check periodically.

**00-9 MAINTENANCE RECOMMENDATIONS  
46-48-49000 SERIES**

**a. Engine Oil**

Engine crankcase oils have a definite effect on ease of starting, oil economy, combustion chamber deposits and engine wear. It is recommended that you use an oil which, according to the label on the can, is: (1) intended for service MS and (2) passes car makers' tests or meets General Motors Standard GM 4745-M. Oils conforming to these types contain detergent additives.

**b. Grade or Viscosity**

The grade or viscosity (SAE number) of engine oil should be selected for the lowest anticipated temperature at which cold engine starting will be required as recommended in the temperature-viscosity chart above.

Oil level should be checked more frequently during the break-in period since somewhat higher oil consumption is normal until piston rings become seated.

The oil level should be maintained between the "operating range" marks on the gauge rod; each space between marks represents one quart. Do not fill above the upper mark.

**c. Engine Oil Change and Viscosity Recommendations**

Anticipated Lowest Temperatures	Use S A E Viscosity Number	Change Your Oil at Least
Above Freezing (+32° F.)	S A E 10W-30 S A E 20W	Every 60 days*
Below Freezing (+32° F. to 0° F.)	S A E 10W S A E 10W-30	Every 60 days*
Below 0° F.	S A E 5W-20 S A E 5W	Every 60 days*

\*Never exceed 6,000 miles between oil changes. During extreme driving conditions which produce oil contamination by dust, water, or other foreign material, the oil should be changed more frequently than every 60 days. Your authorized Buick dealer is well qualified to advise you.

**d. Oil Color**

The color of "Service MS" type oil does not indicate its condition since it normally becomes dark (black or gray) after only a few hundred miles of driving. This is because the detergent content envelopes and holds in suspension extremely fine but harmless soot (soft carbon) and lead particles. The oil filter element does not remove this harmless material but it does remove harmful particles such as road dust, metal chips and hard carbon.

(equivalent to 20 MPH) until the oil is hot, then drain crankcase and oil filter immediately after stopping engine. Fill crankcase with correct quantity and seasonal grade of oil. Install new oil filter element.

**e. Crankcase Flushing**

Flushing the crankcase with oils or solutions other than a good grade of 10-W engine oil is not recommended. When flushing to remove contamination appears advisable, use 3 quarts 10-W oil (4 quarts if filter is drained) and idle the engine at 1000 RPM

**f. Use of Buick HD Concentrate**

Buick HD Concentrate, available through Buick Parts Department under Group 1.850 is a compound of the materials used by oil refiners to manufacture high detergent motor oils. It is intended for use in engines operating under aggravated conditions where engine deposits, rust and corrosion cannot be adequately retarded by motor oils readily available to the average motorist. It is especially recommended for engines operated under restricted conditions such as frequent stops, short trips and slow speeds where such symptoms as sticking valves,

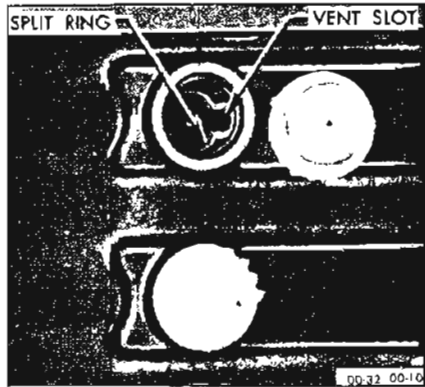

Figure 00-32—Battery Filler Well

valve lifters and rings are noticed.

Although HD Concentrate may be used continually, it is normally unnecessary to use it with every crankcase refill. When used, the instructions on the container should be carefully observed.

**g. Maintenance—Periodically While Vehicle is Being Refueled**

**1. Battery**

Check level. If necessary, add colorless, odorless drinking water to bring level to split ring at bottom of filler wells.

**NOTE:** Do not overfill. Clean top of battery; if wet with acid, neutralize with soda and wash clean. See Figure 00-32.

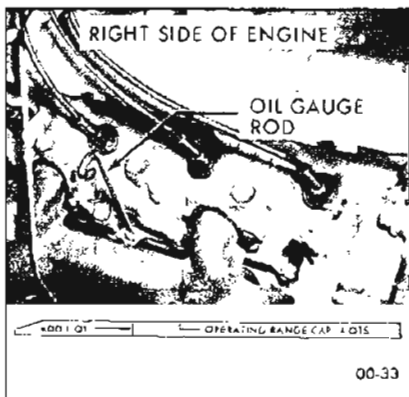

Figure 00-33—Engine Oil Gauge Rod



Figure 00-34—Oil Filter Installation

**2. Tires**

For maximum tire life with corresponding good ride characteristics, maintain the tire pressures recommended in GROUP 100.

**3. Oil Filler Cap**

Check periodically for excessive accumulations of dirt and other material in filter portion of cap. Clean as often as necessary. This can be done by quickly washing in a suitable solvent and dipping in engine oil.

**4. Radiator Coolant**

Radiator coolant level should be checked when the engine is cold if at all possible. If the radiator cap is removed when the system is at normal operating temperature, the coolant will boil and

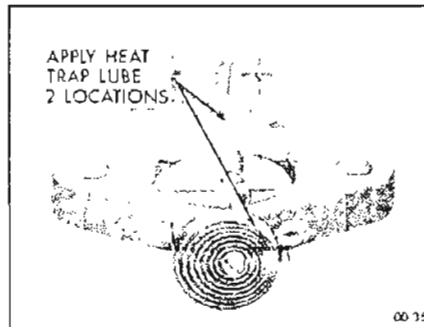

Figure 00-35—Manifold Heat Valve Lubrication Points

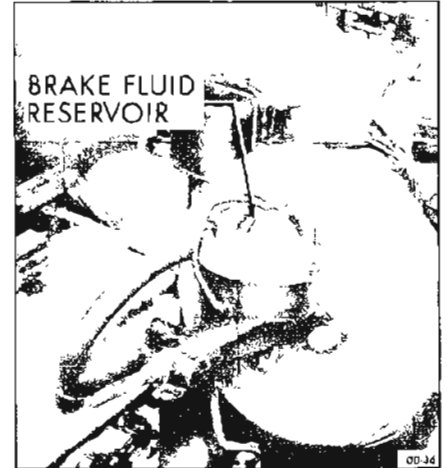

Figure 00-36—Brake Fluid Reservoir

spurt out due to the release of pressure. Coolant lost in this manner must of course be replaced. If coolant should be needed, fill radiator to tip of "Fill Cold" arrow when cold. Do not overfill as loss of coolant due to expansion will result.

**5. Engine Oil**

This check should be performed last to allow the oil to drain back into the pan. Adding oil between changes may be necessary but only if the level is below the lower mark on the dip stick. See Figure 00-33.

**NOTE:** Oil level should only be checked when the engine is

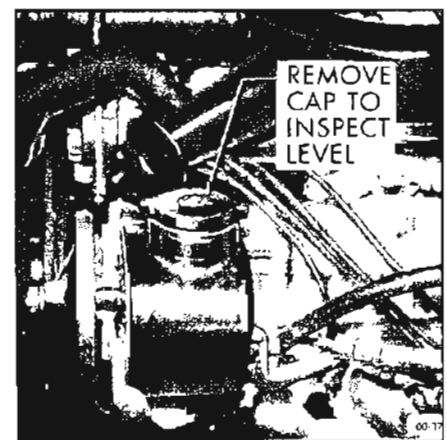

Figure 00-37—Power Steering Pump Reservoir

warm as cold oil drains back to the oil pan very slowly.

#### h. Maintenance—Every 6,000 Miles

##### 1. Engine Oil Change Recommendations

Change oil every 60 days but never exceed 6,000 miles between oil changes. Refer to subparagraph c.

##### 2. Engine Oil Filter Change Recommendations

Replace engine oil filter at the engine oil change which comes nearest 6,000 miles or 6 months, whichever occurs first.

To change, screw filter off the filter base and discard. Wiper the gasket area of the base clean and install a new gasket in the groove of a new AC type PF-7 filter or equivalent. Lubricate the gasket and screw the filter on the nipple of the base until the gasket just touches the base, tighten filter 2/3 turn more. Start engine.

Do not accelerate speed beyond normal idle until oil pressure light goes out. Check filter area for leaks after engine has run for five (5) minutes. See Figure 00-34.

##### 3. Oil Filler Cap

Remove oil filler cap, wash in suitable solvent, dry and dip in engine oil. Allow to drain while performing remainder of 6,000 mile checks. Just before installation, dip again in engine oil, allow to drain, and reinstall.

##### 4. Front Suspension and Steering Linkage

The Buick front suspension has been lubricated with a long-effectiveness lubricant at the factory and should be relubricated with a long-effectiveness lubricant equivalent to General Motors Specification 9985024 every 6,000

miles or six months whichever occurs first.

**NOTE:** If lubricants not intended for long-effectiveness application are used, the lubrication interval should be shortened and should not exceed 2,000 miles.

Wipe dirt from the lubrication fittings and apply the lubricant under pressure at the following points:

Upper Ball Joints (2 fittings)  
Lower Ball Joints (2 fittings)  
Steering Linkage (4 fittings)

##### 5. Manifold Valve Shaft

Place a few drops of "Buick Heat Trap Lube" or equivalent on shaft at each end and rotate shaft to work lubricant into bearings. See Figure 00-35. Buick Heat Trap Lube is available through Buick Parts Warehouses under Group 8.800.

##### 6. Check Fluid Level

**Brake Master Cylinder.** On both manual and power brake jobs, the reservoir is under hood on left side. (On dash panel)

Add fluid as required to bring level to 1/8" below top of filler opening. Use Delco Supreme No. 11 Hydraulic Brake Fluid or equivalent. Never use reclaimed fluid, mineral oil or brake fluids inferior to SAE Standard 70-R-1. See Figure 00-36.

**Manual Transmission.** Check oil level, after allowing time for oil to settle. Clean the surrounding area before removing filler plug. Level should be maintained at filler plug opening by adding SAE 90 Multi-Purpose Gear Lubricant.

**NOTE:** Draining and flushing transmission are not necessary unless the lubricant has become contaminated.

**Automatic Transmission.** Check transmission oil level, with transmission oil at operating

temperature (180° approximate), transmission in park and engine idling.

Remove gauge rod located under right side of hood, wipe dry with clean cloth, then reinstall to full depth. Remove rod and note oil level.

If oil level is below the "ADD" mark on gauge rod, add oil but do not fill above the FULL mark. Distance between the FULL and ADD marks represents approximately one pint.

**Power Steering Gear.** Thoroughly clean dirt from reservoir cap on top of oil pump, then remove cap. With system warmed up, maintain level with Buick power steering gear fluid or equivalent. See Figure 00-37.

**Standard Differential Rear Axle.** Check lubricant level after allowing time for lube to settle. Clean the surrounding area before removing filler plug. Level should be maintained at filler plug opening to 1/4" below by adding SAE 90 Multi-Purpose Gear Lubricant (MIL-L-2105B). When car is operated in temperatures continuously below -10°F, use 80 Multi-Purpose Gear Lubricant.

**NOTE:** Draining and flushing is not recommended unless the lubricant has become contaminated. When complete refilling is necessary, SAE 90 Multi-Purpose Gear Lubricant may be used provided the axle has been in service for 1,000 miles or more. Axles in less than 1,000 miles must not be completely refilled with any lubricant other than Factory Hypoid Lubricant.

**Positive Traction Rear Axle.** This axle can be identified by a tag attached to a bolt on the rear cover reading "Use limited slip diff. lube only."

On all Positive Traction axles, check lubrication level after allowing time for lubricant to settle. Clean the surrounding area

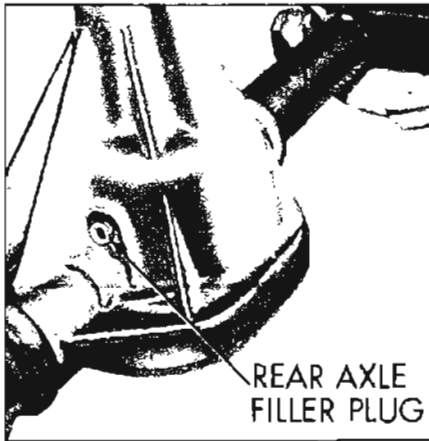

Figure 00-38—Rear Axle Filler Plug

before removing filler plug. Level should be maintained at filler plug opening to 1/4" below. Add only lubricant conforming to Buick Specification #723. See Figure 00-39.

7. Minor Lubrication

Occasionally lubricate the pivot points of moving parts, such as door and hood hinges and latches, door hold open, clutch, transmission, parking brake and folding top linkage with Lubriplate, or equivalent, or engine oil where applicable. A small quantity of lock lubricant occasionally applied to lock cylinders will prevent sticking. See details under Maintenance - As Required.

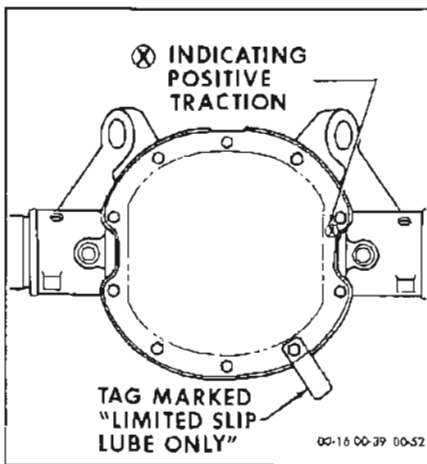

Figure 00-39—Positive Traction Axle Identification

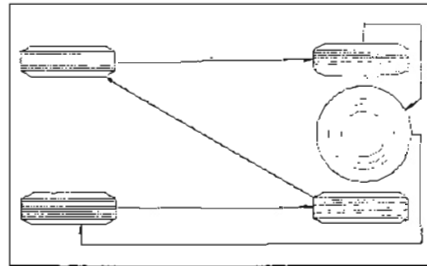

Figure 00-40—Tire Rotation Method

**NOTE:** Do not lubricate carburetor or throttle linkage.

8. Body Rubber Parts

Door, hood, and rear compartment rubber weatherstrips and bumpers, and door bottom drain hole sealing strips may be kept pliable and quiet by the application of a light coat of Buick 4-X Compound or suitable silicone lubricant equivalent.

9. Tires

For best tire mileage, switch tires as recommended in GROUP 100.

10. Constant Velocity Universal Joint Center Ball (49000)

Rotate propeller shaft until fitting is visible through rear hole in frame tunnel. See Figure 00-41. Insert special grease gun nozzle (Alemite #326375 or equivalent) through frame tunnel to bear solidly against fitting. One or two shots from a lever type grease gun are sufficient.

Lubricating the constant velocity joint on certain hoists such as the frame contact type can be difficult as they allow the axle to drop and thus move the CV joint grease fitting away from the access hole. To correct, either the axle must be raised or the propeller shaft disconnected from the rear companion flange. **CAUTION:** Reassembly of the propeller shaft should be carefully done as instructed in GROUP 40.

**NOTE:** Multi-Purpose Grease EP #1 grade is the only lubricant applicable at this point. Do not use ordinary chassis lube. EP #1 lube is available through most oil companies.

11. Electro-Cruise

Remove Electro-Cruise air filter element by bending back the four

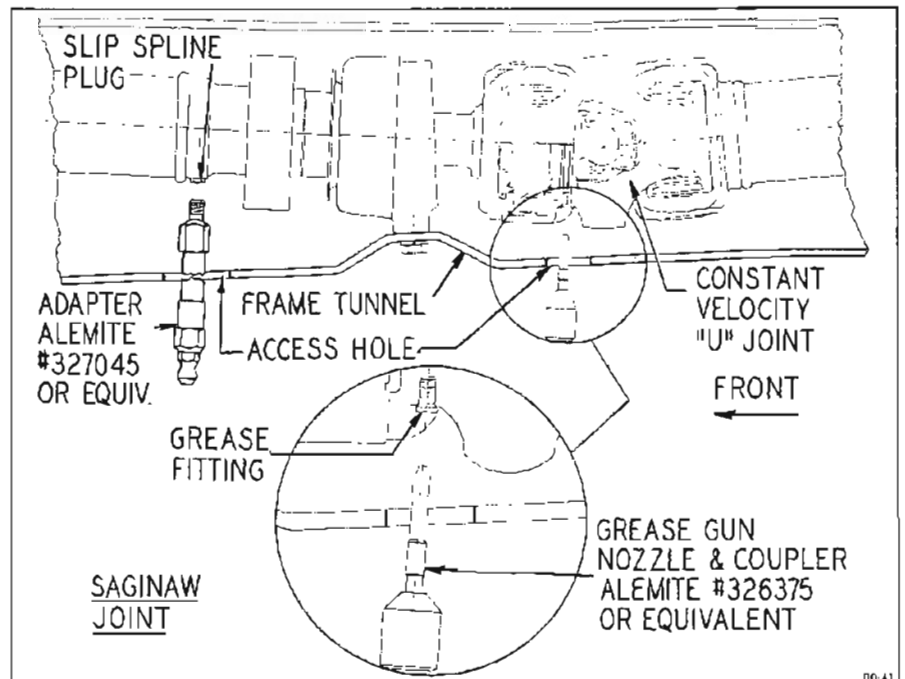

Figure 00-41—Propeller Shaft Lubrication Points

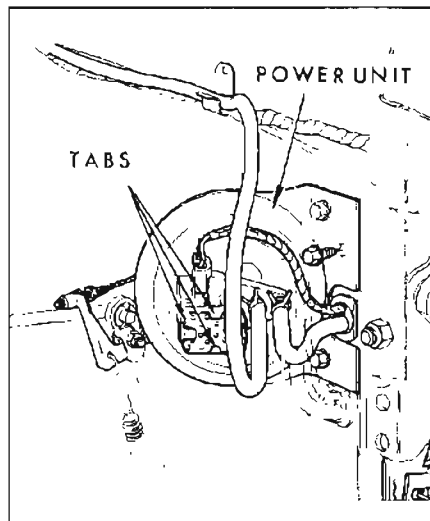

Figure 00-42—Electro-Cruise  
Air Filter

tabs on the power unit and removing the outer screen, element, and inner screen. See Figure 00-42.

Clean screens and element in a suitable solvent. Squeeze solvent out of element.

**NOTE:** Do not oil element.

Reinstall inner screen, element, and outer screen; retain with tabs.

#### 12. Clutch Lash

Should be adjusted every 6,000 miles.

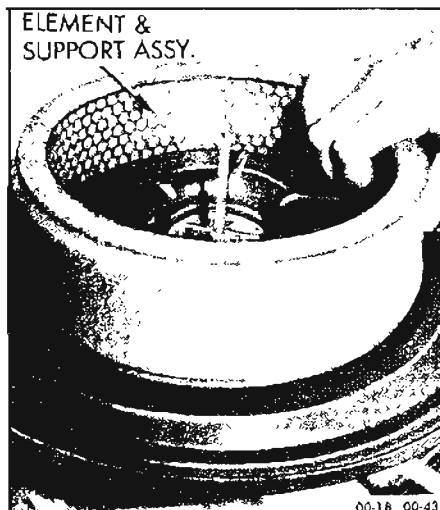

Figure 00-43—Air Cleaner Element  
and Support

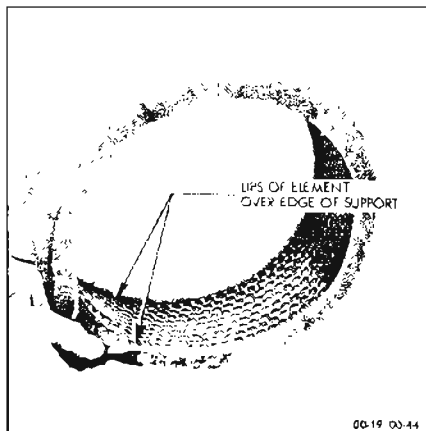

Figure 00-44—Installing Element  
on Support

#### i. Maintenance—Every 12,000 Miles or Once a Year

(Suggested in addition to the 6,000 mile recommendations.)

##### 1. Tune-Care

Tune-Care includes: Clean and/or replace spark plugs and ignition points; check compression, battery, cranking system, charging system, fuel pump, choke, hose connections, belts, carburetor; set engine timing and adjust idle speed.

##### 2. Engine Air Cleaner (Exc. Super Wildcat Engine)

Recommendation is to service every 12,000 miles. If car is operated in dusty territory, check condition of air cleaner element more frequently and clean if dirty.

To clean the element, carefully remove from the mesh support, wash in kerosene and squeeze out. See Figure 00-43.

**CAUTION:** Take precautions against the possibility of fire. Do not wring the element or it may be torn. Wrap the element in a dry cloth and squeeze to remove all possible solvent.

Oil the element liberally with engine oil and squeeze to evenly

distribute the oil through the element and remove excess.

**NOTE:** The element should be only damp with oil, not dripping.

Reinstall the element on the mesh support taking care to have the edges of the element over the support to affect a good seal. See Figure 00-44. Clean any oil or accumulated dirt out of the air cleaner housing before installing element.

**NOTE:** If the element becomes damaged, replace with AC Type A96C or equivalent on LeSabres and AC Type A202C on all other models except Gran Sport models.

##### 3. Engine Air Cleaner Element (Gran Sport Models)

Replacement of element is recommended every 12,000 miles, oftener under severe dust conditions. Service with AC Type A85C or equivalent for maximum engine protection. Element must not be washed, oiled, tapped or blown with an air hose.

##### 4. Positive Crankcase Ventilator Valve

Replace positive crankcase ventilation valve with a correctly calibrated valve such as AC Type CV-683 or equivalent for V-8 engines, or AC Type CV-684 or equivalent for V-6 engines.

Inspect P.C.V. system hoses for leaks and possible obstructions. Make certain all connections are tight. Replace any defective parts if necessary.

On California cars, the breather assembly should be inspected and cleaned. On Standard P.C.V. equipped cars, the normal oil filler cap maintenance recommendations specified at 6,000 miles should be performed.

##### 5. Engine Belts

Inspect belts for cracks and for proper tension.

6. Propeller Shaft Slip Spline

Each 12,000 miles, rotate propeller shaft so plug in propeller shaft is accessible through front hole in frame tunnel. See Figure 00-41. Remove plug and install grease fitting. Apply multi-purpose grease EP #1 Grade. Do not use ordinary chassis lube. Remove grease fitting and re-install plug. EP #1 lube is available through many oil companies.

**NOTE:** Special extended length grease fittings to make this operation simple and fast are available from lubrication equipment jobbers.

j. Maintenance—Every 18,000 Miles

(Suggested in addition to the 6,000 mile recommendations.)

1. Brakes

Examine brake linings for wear, and the self-adjusting mechanism for proper functioning. Although linings may not be excessively worn, this check will indicate when another inspection should be made. If required, use Buick Factory Engineering replacement linings or equivalent. Lubricate the self-adjusting mechanism adjusting screw with Delco Moraine Special Brake Lubricant or equivalent.

2. Front Wheel Bearings

There is no periodic lubrication schedule for front wheel bearings. They may be relubricated whenever brake drums are removed. Always follow with the correct bearing adjustment as outlined in GROUP 100.

k. Maintenance—Every 24,000 Miles

1. Fuel Filter

Replacement of the disposable filter is recommended. More

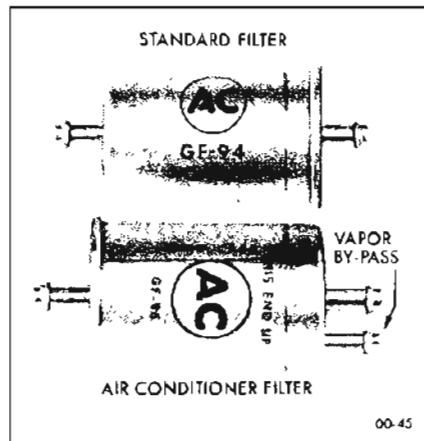

Figure 00-45—Replacement Fuel Filters

frequent replacement may be necessary if contaminants have entered the fuel system. Replace with filter type GF-94 or equivalent on non-air conditioned cars and type GF-415 or equivalent for air conditioned cars.

2. Automatic Transmission

At this interval, the automatic transmission should be drained, the oil pan cleaned, the oil strainer cleaned, and new oil added.

Approved Oils for Buick Automatic Transmissions - The following oils are approved for Buick Automatic Transmissions and no other fluid should be used:

Special Buick Oil - available through Buick Warehouses under Group 4.101.

Automatic Transmission Fluid Type A - Use only Automatic Transmission Fluid identified by the mark "AQ-ATF" followed by a number and the Suffix A. (AQ-ATF-XXXX-A).

Cleaning Oil Pan

- Remove bolts from transmission oil pan, remove pan, and allow transmission to drain.
- Carefully remove strainer and pipe assembly from transmission.
- Inspect seal near end of pipe.

If it is damaged in any way, discard and replace with new seal. Clean strainer in suitable solvent.

- Place seal on strainer.
- Carefully install strainer on transmission, being careful not to cut or tear the seal at the end of the pipe.
- Clean the oil pan and re-install on transmission. Torque pan bolts to 8-12 lb. ft.

Re-fill Procedure

- Fill transmission with 5 pints of transmission fluid.
- Start engine and allow to idle. **DO NOT RACE ENGINE.**
- Finish filling transmission until fluid level showing on the gauge rod is within 1/2" of Full mark.

3. Manual Steering Gear (LeSabres and Wildcats Only)

At this interval, the manual steering gear lubricant level should be checked. Remove bolt on gear cover marked "Lube". Add chassis lubricant conforming to Buick Specification 742 if necessary.

I. Maintenance—Seasonal

1. Anti-Freeze

A permanent glycol type corrosion inhibitor and cooling system anti-freeze solution designed for year around use, has been installed in the vehicle at the factory. This solution conforms to General Motors Specification 1899-M.

Although this coolant should be used continuously throughout the year, it should be drained once every two years, the cooling system flushed, and permanent type anti-freeze (conforming to GM Specification 1899-M) installed. Water, Methanol, and alcohol type anti-freeze are not recommended.

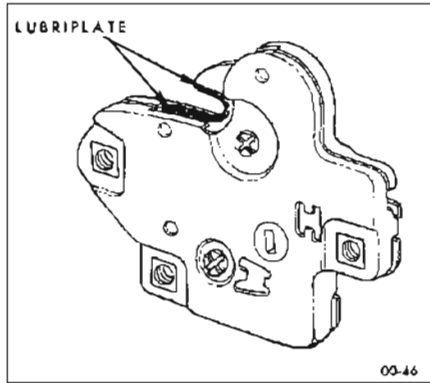

Figure 00-46—Rear Compartment Lid and Tail Gate Lock

If water alone must be used as coolant in an emergency, it is extremely important that Buick Heavy Duty Cooling System Protector and Water Pump Lubricant be added to the cooling system as soon as practical. If any other cooling system protector is used, make certain that the label states that the material conforms to General Motors Specification 1894-M.

2. Air Conditioner

It is recommended that the air conditioner be operated for a few minutes every two weeks regardless of the season. This practice will help keep the internal parts of the compressor lubricated. In addition, the system should be functionally checked by the dealer each spring in preparation for summer operation.

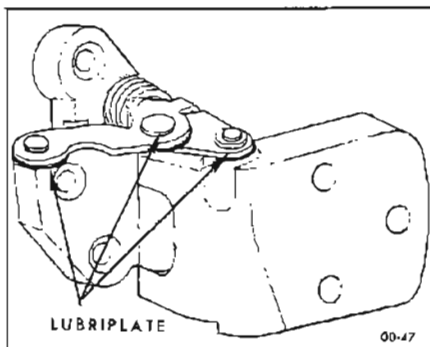

Figure 00-47—Front Door Hinge Hold-Open

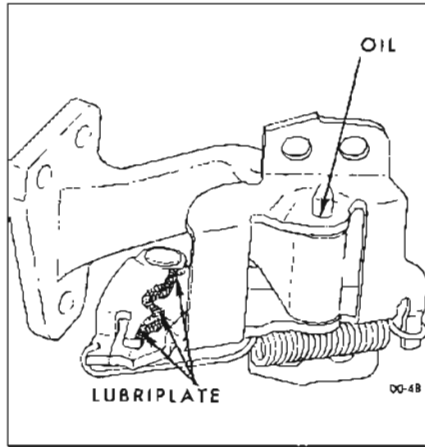

Figure 00-48—Rear Door Hinge Hold-Open

Keep insects and dirt from accumulating on the air conditioner condenser.

m. Maintenance—As Required

1. Body Lubrication

Lubricate the following areas with Lubriplate:

Front Door Hinge Hold-Open. See Figure 00-47.

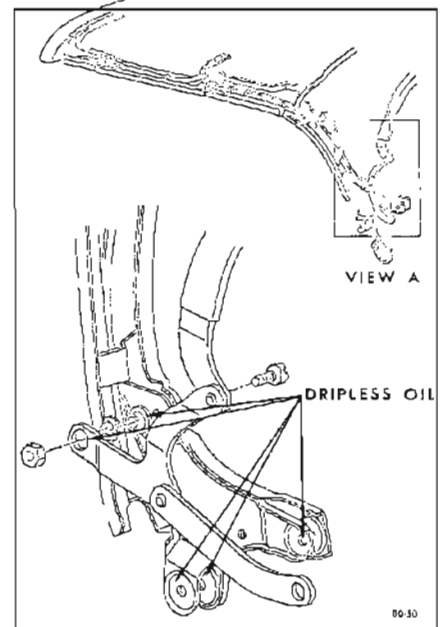

Figure 00-50—Folding Top Linkage

Rear Door Hinge Hold-Open. See Figure 00-48.

Rear Compartment Lid and Tail Gate Locks. See Figure 00-46.

Rear Compartment Lid Hinges and Torque Rods.

Door Jamb Switch

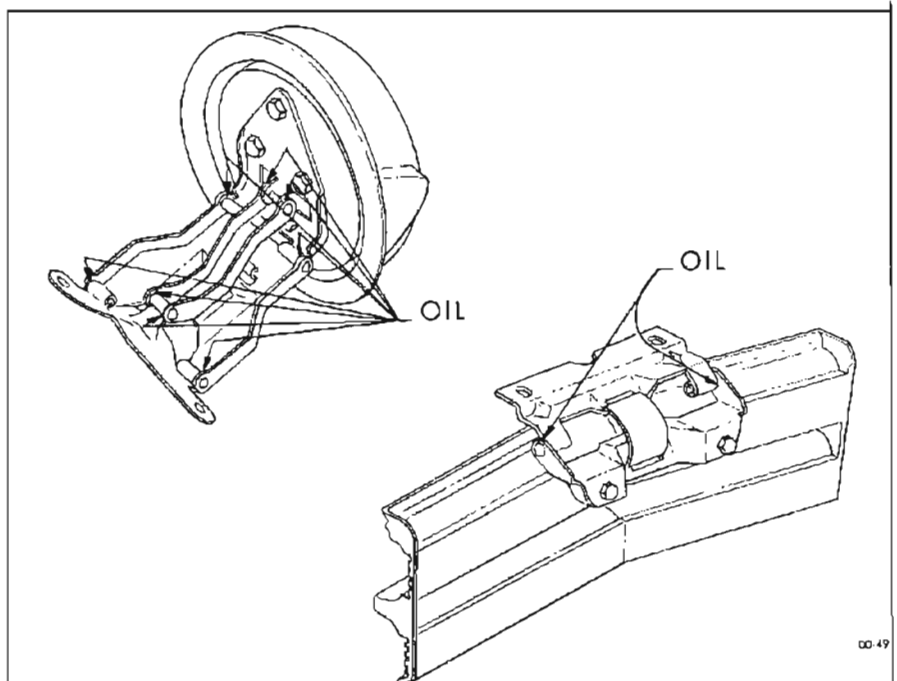

Figure 00-49—Gas Tank Filler Door

Lubricate the following areas with dripless oil:

- Instrument Panel Glove Box Door.
- Gas Tank Filler Door. See Figure 00-49.
- Tail Gate Hinge.
- Folding Top Linkage. See Figure 00-59.

Lubricate the following areas with the lubricant specified:

- Door Lock Striker Fort Bolt - Stick Type Lubricant. See Figure 00-51.
- Door and Rear Compartment Lock Cylinders - Lock Lubricant.
- Folding Top Lift Cylinder Piston Rods - Cloth dampened in brake fluid.
- Windshield Wiper Cams - Silicone Lube.

2. Chassis Lubrication

- Hood Latches and Hinges - Lubricate lightly with Lubriplate or equivalent.
- Shift Linkage - Lubricate with wheel bearing grease.
- Clutch Linkage - Lubricate with wheel bearing grease.

n. Rear Axle Lubricant Recommendations

1. Standard Differential Axle

Buick standard rear axles are filled at the factory with a special hypoid gear lubricant. It is not necessary to remove the original lubricant at any time except when it has become contaminated or when it is required for inspection of parts or for repairs. Therefore, there is no drain hole in the rear axle housing.

Draining and flushing is not recommended unless the lubricant has become contaminated. When complete refilling is necessary, Multi-Purpose Gear Lubricant (conforming to specification MIL-

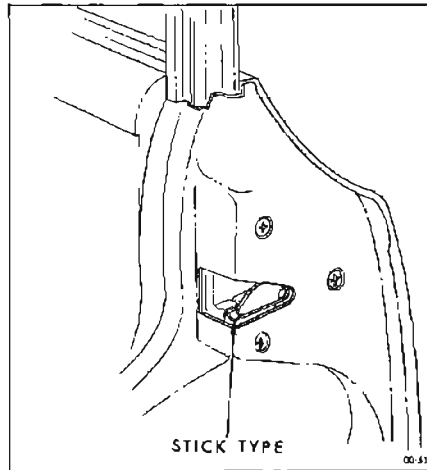

Figure 00-51—Door Lock Striker Bolt

L-2105B) may be used provided the axle has been in service for 1,000 miles or more. Axles with less than 1,000 miles service must not be completely refilled with any lubricant other than Factory Hypoid Lubricant.

The lube is packaged with replacement ring and pinion gear sets and is also available through the Buick Parts Department under Group 5.535.

2. Positive Traction Differential Axle

Buick Positive Traction Differential Axles are filled at the Factory with a special lubricant conforming to Buick Specification No. 723.

It is not necessary to remove the lubricant at any time except when it has become contaminated or when it is required for inspection of parts or for repairs. There is no drain hole in the rear axle housing.

In all cases of adding lubricant to bring to proper level or complete refilling of Positive Traction Rear Axle, only lubricant conforming to Buick Specification No. 723 should be used. Lubricant conforming to this specification may be obtained from any Buick

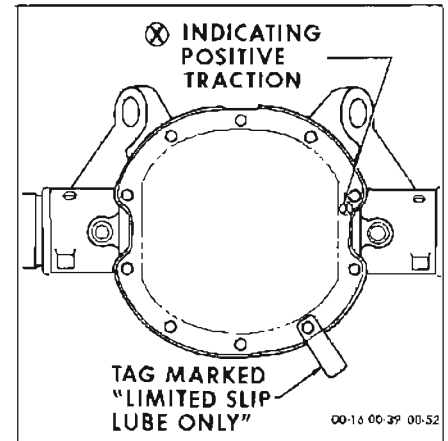

Figure 00-52—Positive Traction Identification

Parts Warehouse under Group 5.535.

To identify Positive Traction rear axles, a tag stating "Use Limited Slip Dff. Lube Only" is attached to the lower right bolt on the rear axle rear cover. See Figure 00-52.

a. Vehicle Operation Under Dusty Conditions

When cars are operated in adverse dusty climates or conditions, the following precautions should be taken to prevent dirt and other foreign materials from entering the engine.

1. Change Engine Oil - Change more often than is recommended in subparagraph a. The severity of the conditions should determine the frequency of oil changes.
2. Oil Filter - Change each time that the oil is changed under these conditions.
3. Oil Filler Cap - Check for presence of dust and dirt each time car is refueled. Wash and re-oil if necessary.
4. Air Cleaner Element - If amount of dirt and foreign material is excessive, element should be replaced on Gran Sport models and cleaned on all engines.