

CHEVROLET TRUCKS

GM BOOKLETS
CHEV TRUCK

1941
#2 c.1

1941 #2

FILE COPY

FROM
CAMPBELL-EWALD CO.
LIBRARY

*Must be returned promptly
and in good condition*

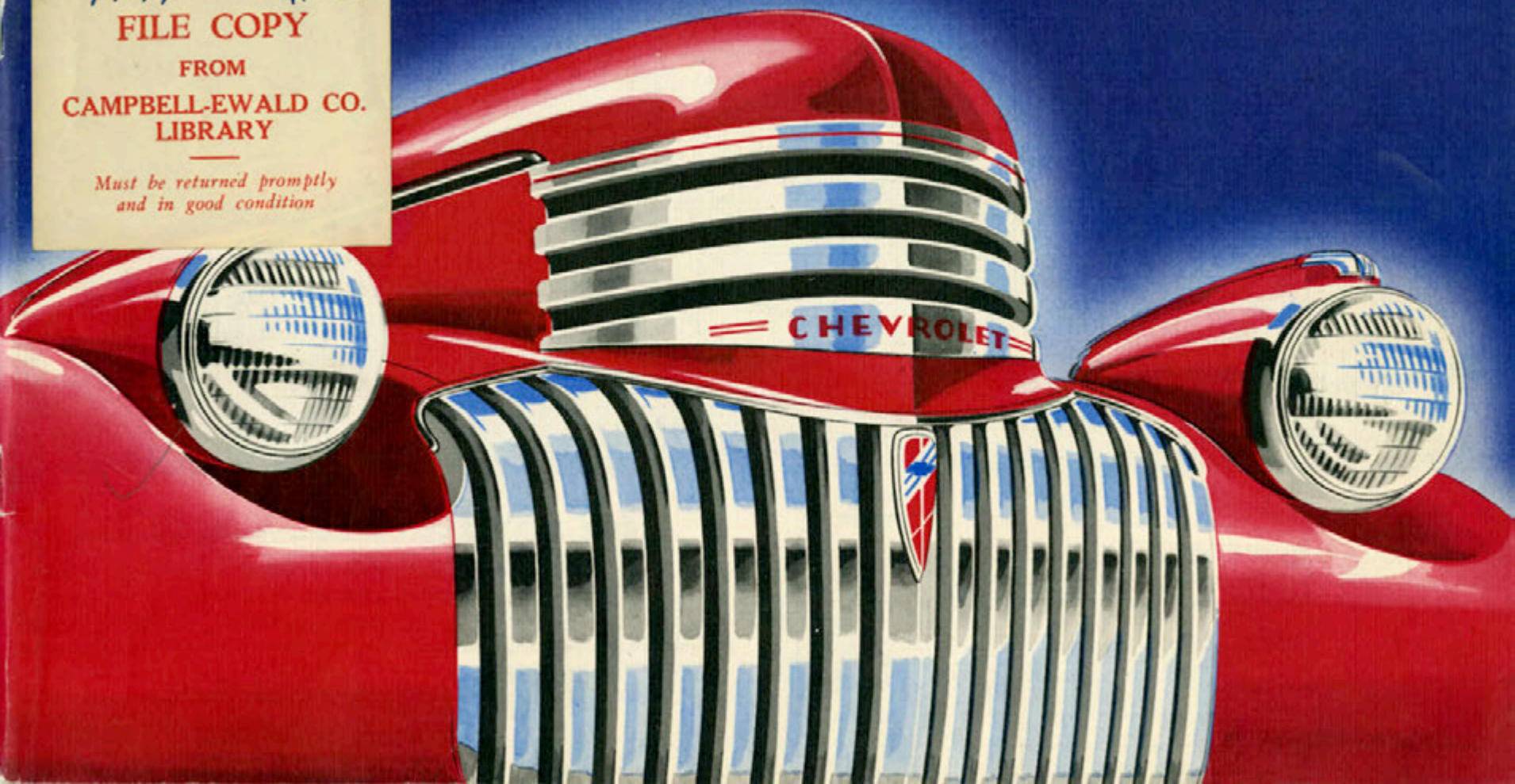

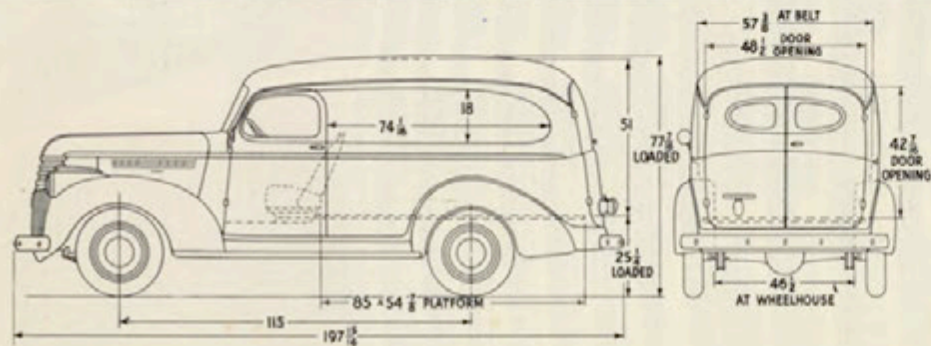
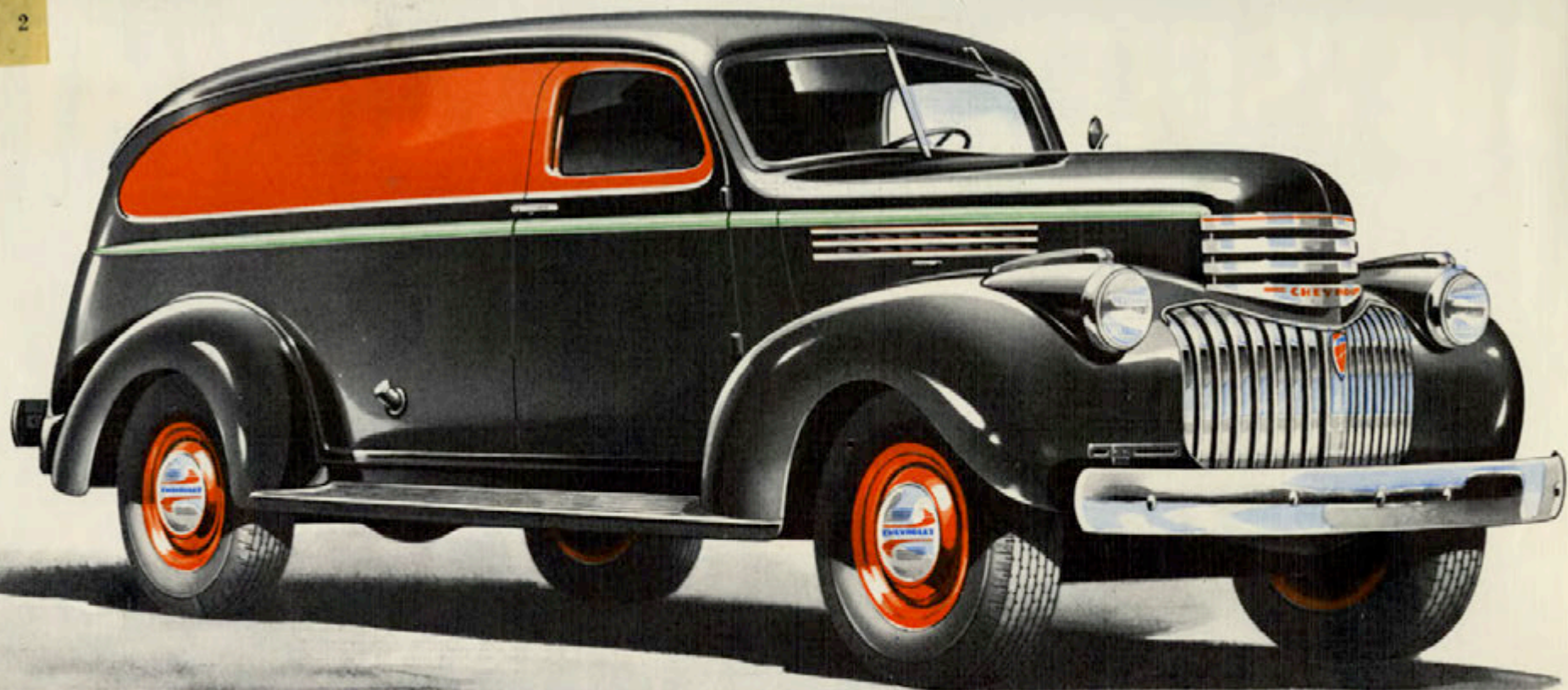

LIGHT DELIVERY PANEL—115-inch Wheelbase

An ideal unit for every business requiring speedy and efficient delivery service of numerous small packages or light merchandise . . . Continuous sign panel devised for maximum advertising display . . . Roof and sides insulated . . . Seat adjustable over range of three inches . . . Seat cushion padded with latex-impregnated hair . . . Wood floor with steel skid strips . . . Dome light in load compartment (For body details, see page 32.)

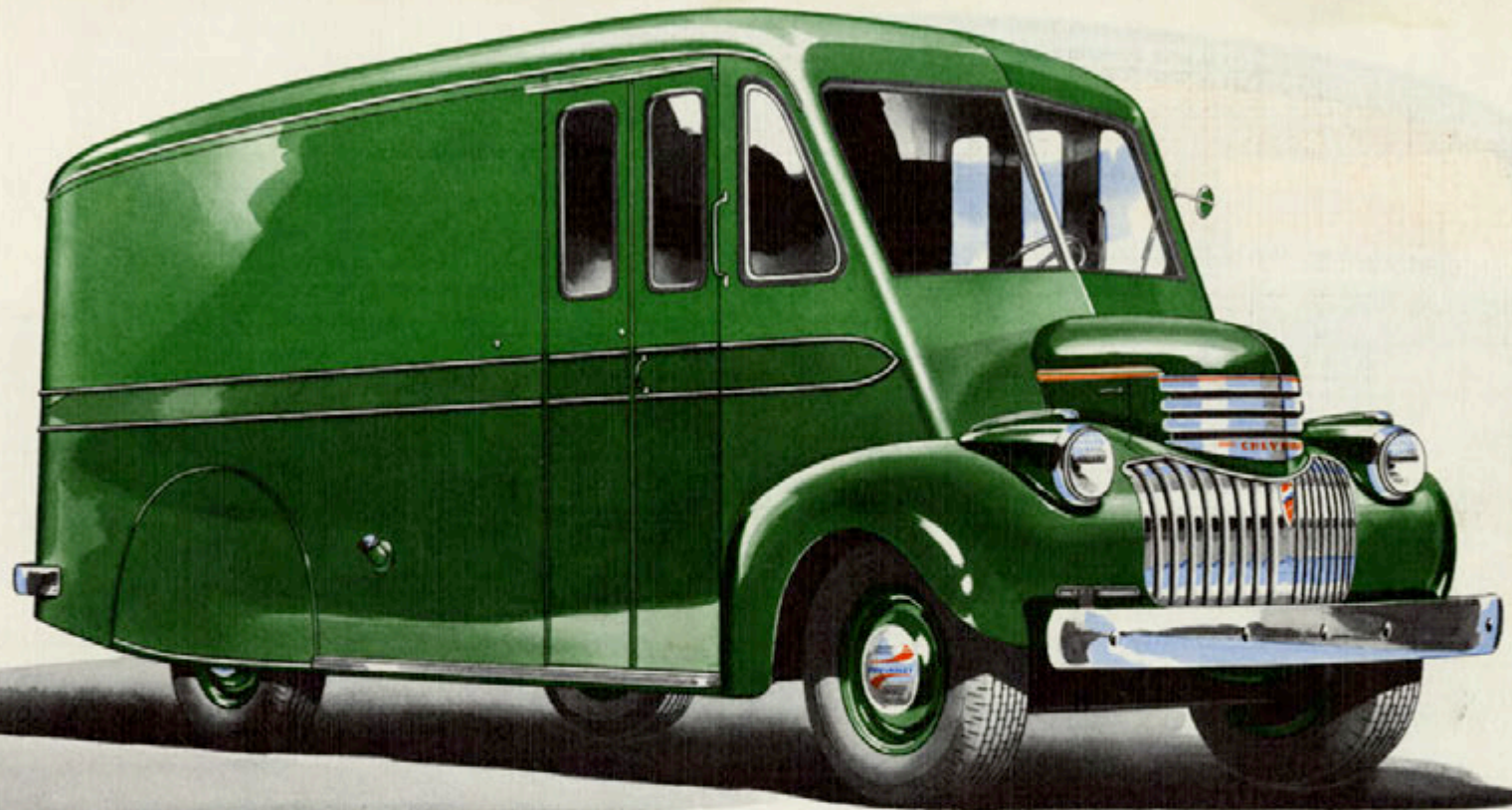

DUBL-DUTI PACKAGE DELIVERY
115-inch Wheelbase

Specially designed to bring increased economy and efficiency in house-to-house delivery operations, or multiple-stop routes. . . . Cubic-foot load

capacity is virtually double that of conventional trucks of the same wheelbase. . . . Driver convenience in operating and in handling the load eliminates waste effort and waste energy. . . . All-steel body with heavy roof and side panels attached to sturdy steel bows and channels. . . . Bodies are available in five different rear-end styles.

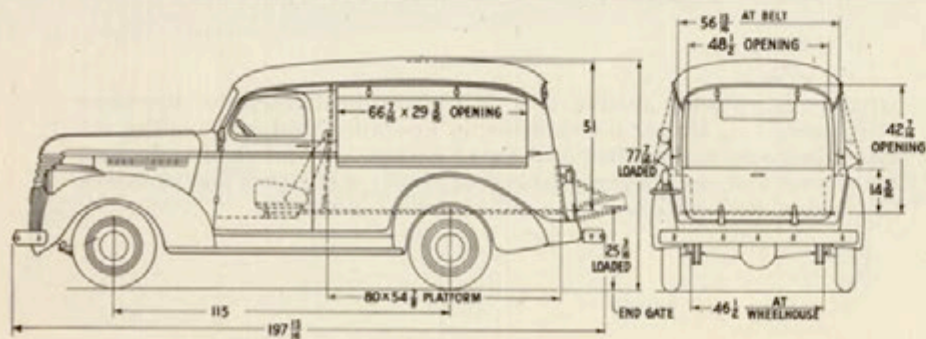
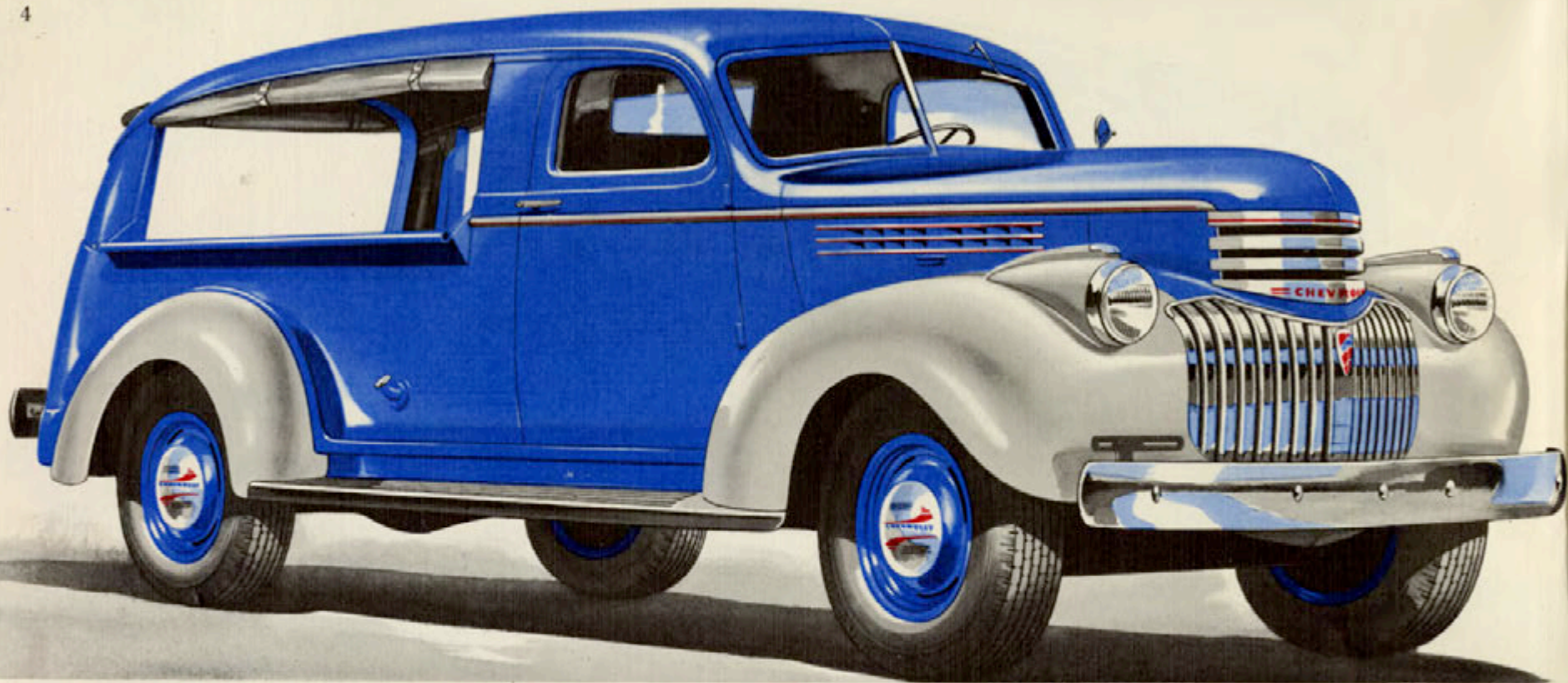

LIGHT DELIVERY CANOPY EXPRESS **115-inch Wheelbase**

All-steel body structure, one-piece roof . . . Wood floor with steel skid strips . . . Waterproof side and rear curtains are standard equipment (heavy mesh wire screens optional at slight extra cost) . . . Easy-action slam-type tail-gate, heavily reinforced, with automatic fastening (For body details, see page 33.) This body style also furnished on 134 $\frac{1}{2}$ -inch wheelbase Heavy Duty chassis.

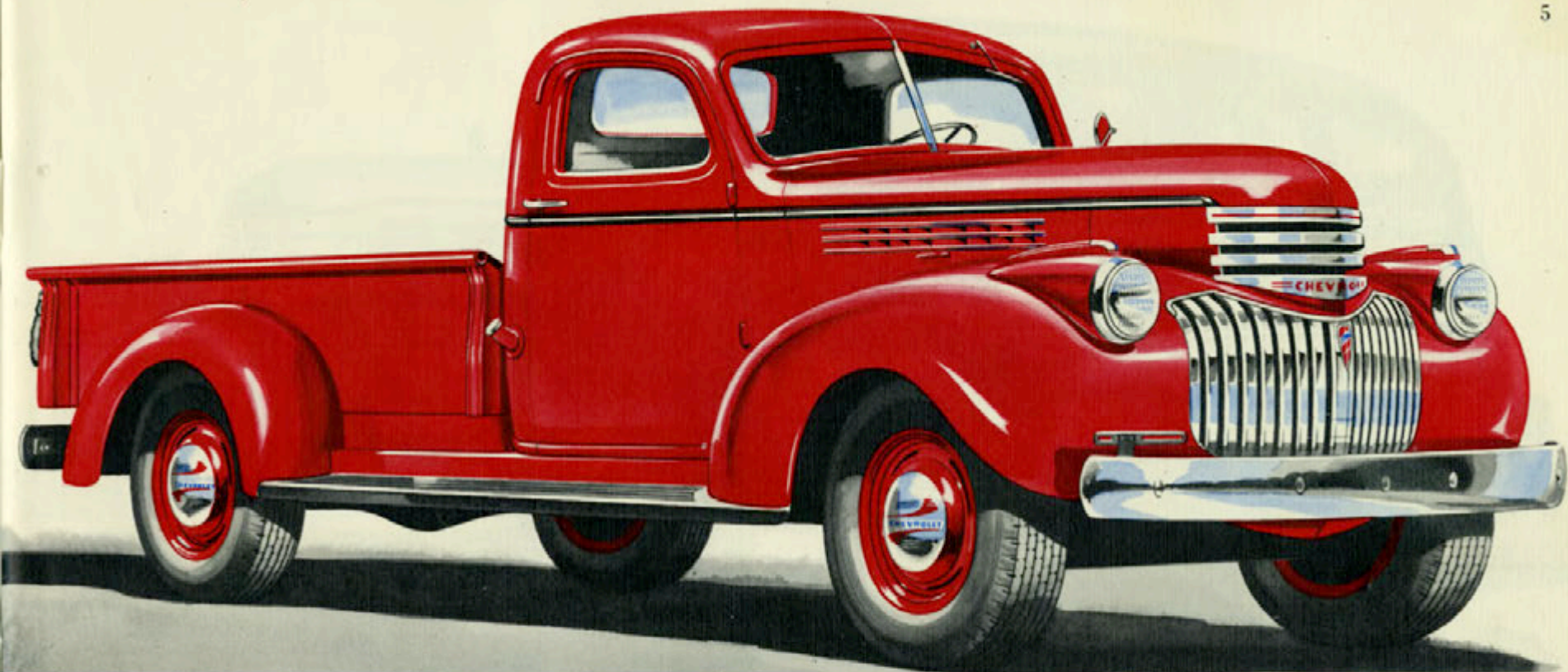

LIGHT DELIVERY PICK-UP—115-inch Wheelbase

Standard Chevrolet all-steel cab (see page 30), fully streamlined . . . All-steel body structure . . . All body metal treated to prevent rust . . . Unobstructed load floor . . . Reinforced end-gate with anti-rattle fastening (For body details, see page 34.)

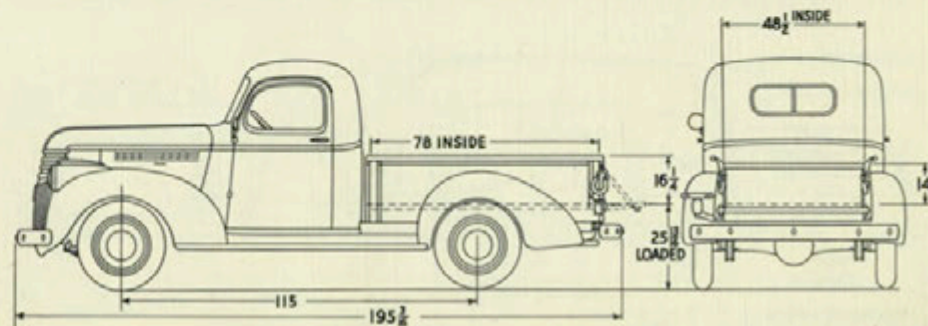

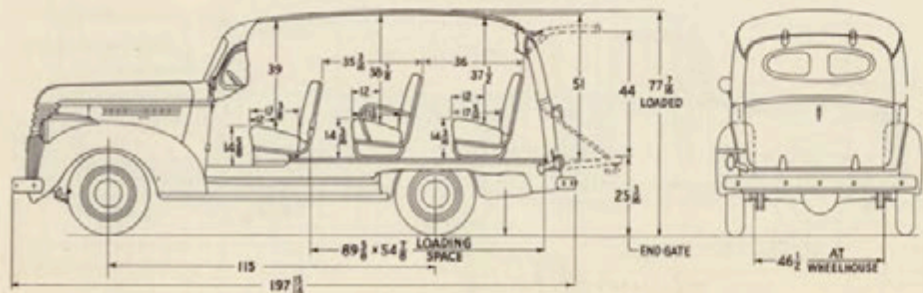
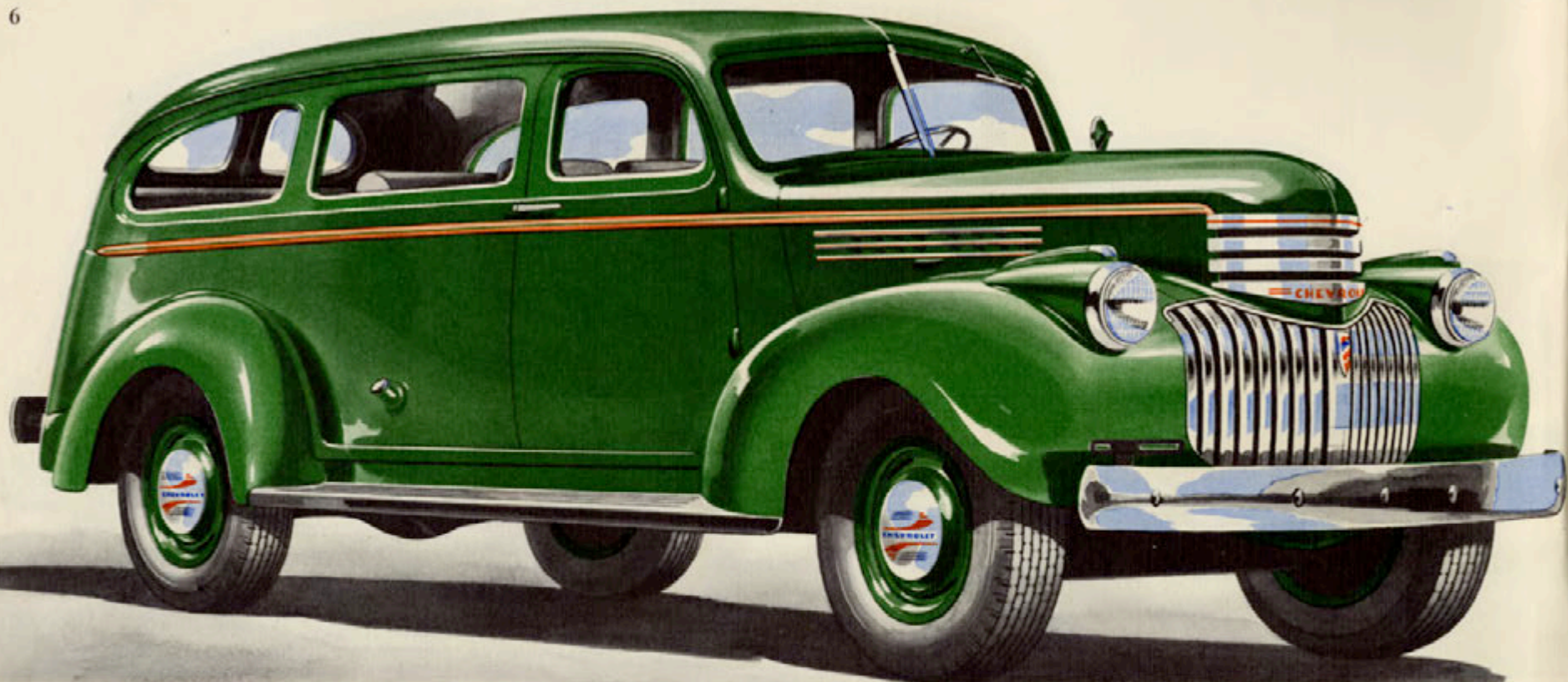

CARRYALL SUBURBAN—115-inch Wheelbase

A handsome eight-passenger vehicle, easily converted for transporting a wide variety of loads . . . Quick-action seat fasteners facilitate change-over . . . Specially designed for full comfort as a passenger vehicle, having large-capacity tires, deeply upholstered seats, ride stabilizer and shock absorbers . . . Rear closure opens with lift-gate and tail-gate. (For body details, see page 33.)

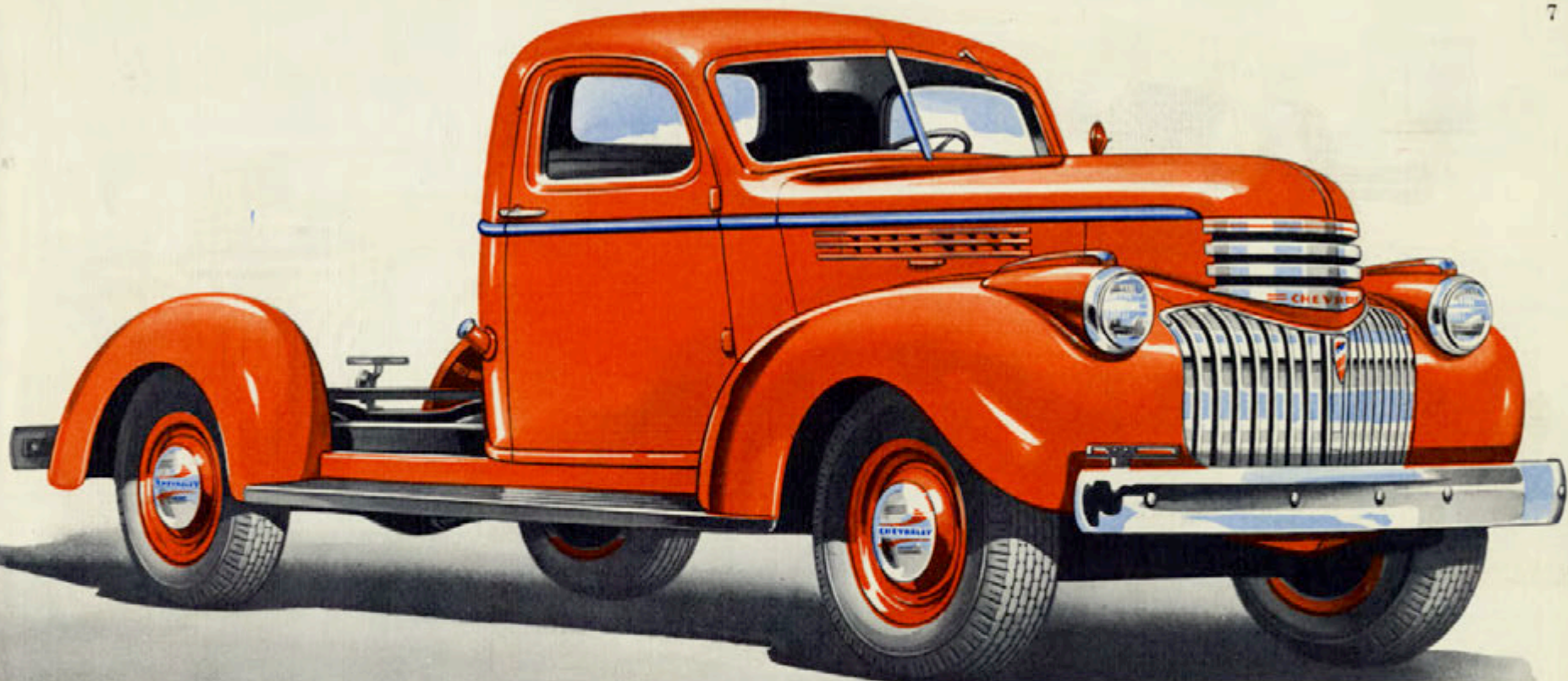

LIGHT DELIVERY CHASSIS WITH CAB

115-inch Wheelbase

Chassis built of special truck units throughout . . . Suitable for mounting of bodies for transportation of half-ton loads . . . Equipped with three-speed Syncro-Mesh, all-helical carburized gear transmission (four-speed transmission at extra cost) . . . 18-gallon fuel tank in cab (For chassis and cab details, see pages 8, 9, and 30.)

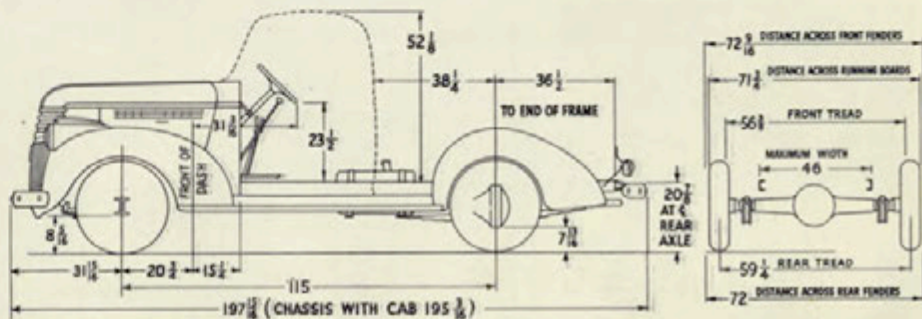

Light Delivery

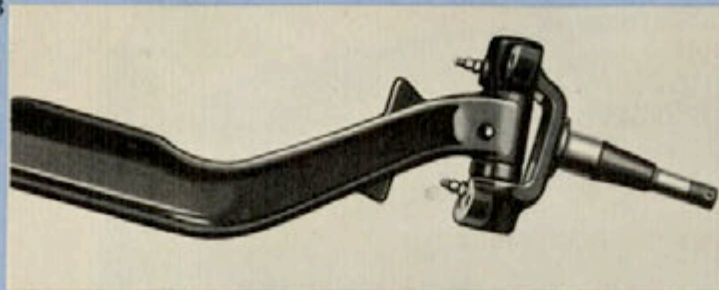

Front Axle—Drop-forged heat-treated I-beam, improved for 1941, with larger and stronger king pins, steering spindle and front wheel inner bearing.

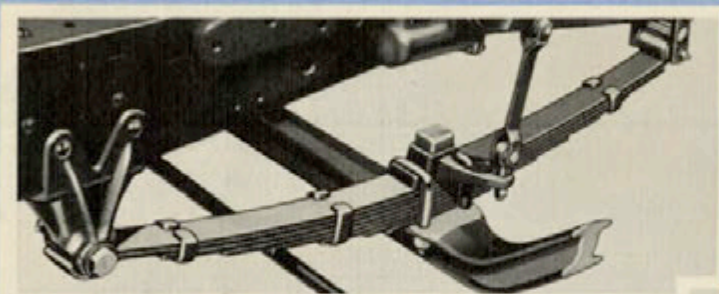

Front Springs—Seven leaves, 36 inches long by $1\frac{3}{4}$ inches wide. The spring is flat under load to give the best steering and riding action.

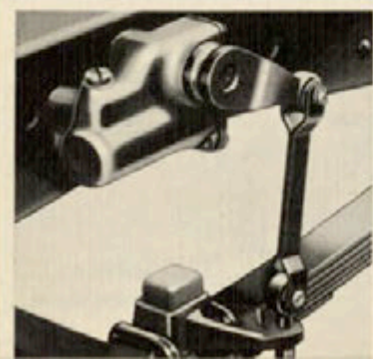

Shock Absorbers—Delco hydraulics, single-acting front and rear, add to driver comfort, protect the truck and its load, and give more positive steering control.

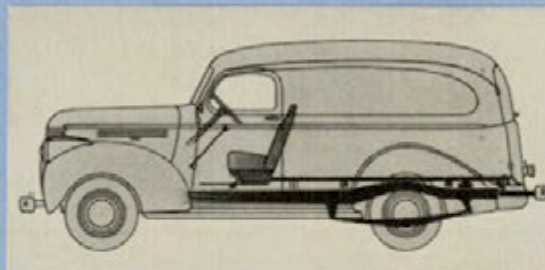

Full-Length Body Support—Chevrolet's special design of truck frame provides a solid foundation for the body from end to end, maintaining alignment and greatly prolonging the life of the body.

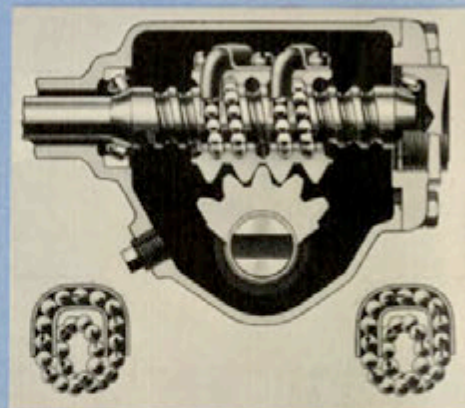

Steering—Ball bearing worm and nut steering gear, new for 1941, promotes ease of steering and durability. Sixty-six bearing balls roll continuously in two spiral races.

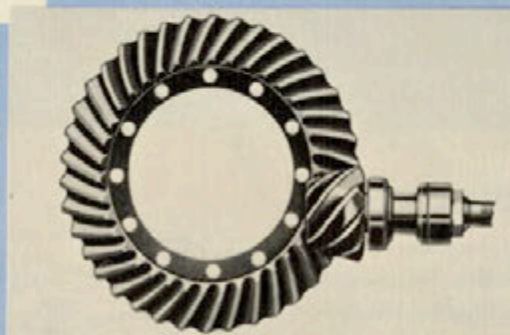

Rear Axle—Hypoid drive gears give a new maximum of strength and durability. Differential bearings are barrel roller type.

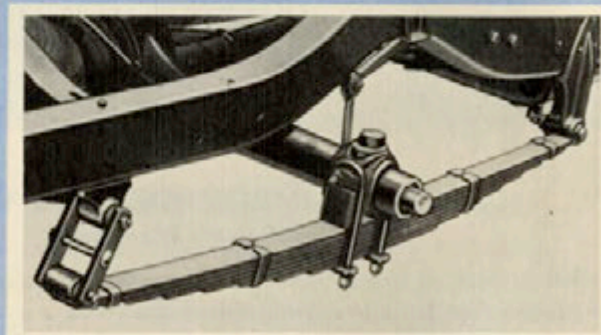

Rear Springs—Eight leaves, 54 $\frac{1}{2}$ inches long by $1\frac{3}{4}$ inches wide. Threaded-type rear shackles having large bearing area prevent sideway.

CHEVROLET

Chassis Features

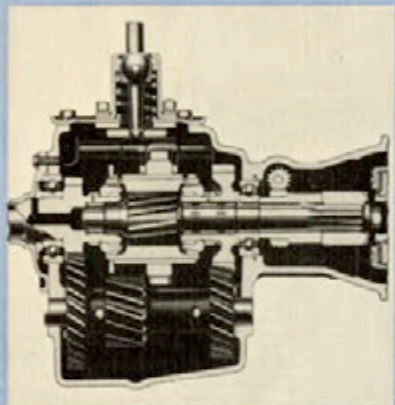

Transmission—The Syncro-Mesh three-speed transmission (left), with all-helical carburized gears and with anti-friction bearings for forward speed gears, is standard on Light Delivery models. Available at small extra cost is the Chevrolet four-speed transmission, a heavy duty unit, with anti-friction bearings for all gears except reverse.

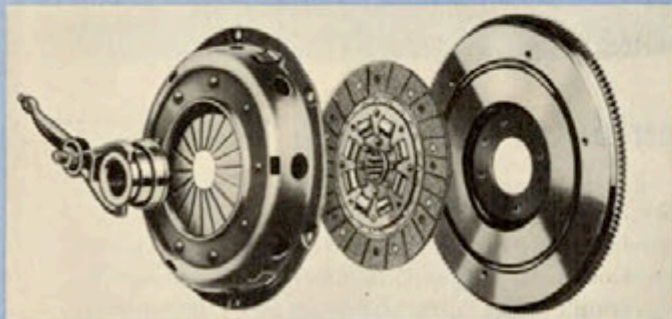
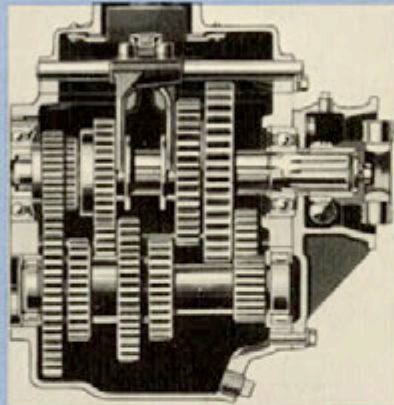

Diaphragm Spring Clutch—A single disc spring is used instead of multiple coil springs, resulting in unusually light pedal pressure, reduced weight, and longer clutch lining life due to even pressure distribution.

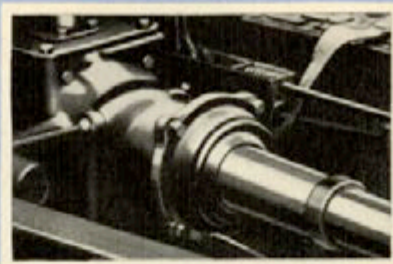

Universal Joint—Power losses are minimized and smoothness and durability are increased by the use of needle bearings.

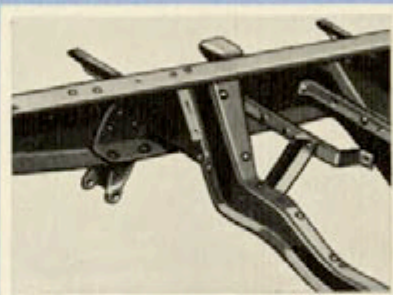

Frame—Channel-section side-rails and flanged or box-section cross-members, with "alligator jaw" attachments.

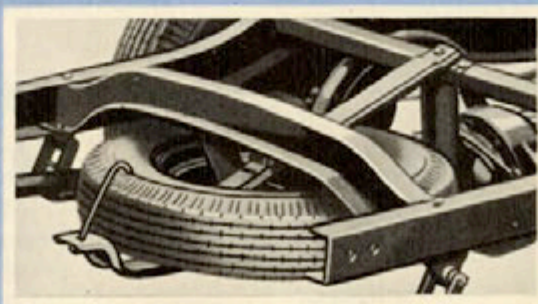

Mono-Rail Tire Carrier—The spare wheel is securely mounted, yet easily accessible.

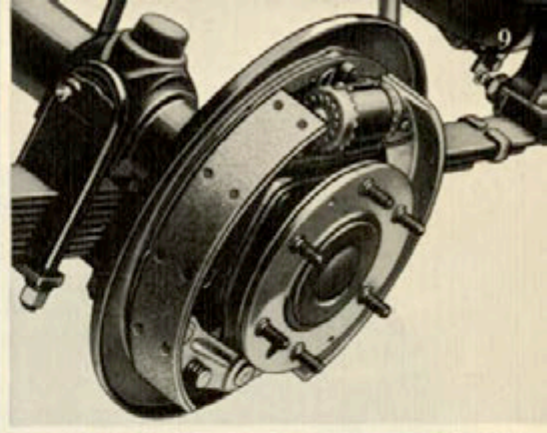

Hydraulic Brakes—Chevrolet's exclusive linkage assures positive action, and full contact of the self-aligning brake shoes with the drum.

Stabilized Front End—The radiator, front fenders and hood are rigidly supported by a massive framework of steel supported on a centered rubber mounting.

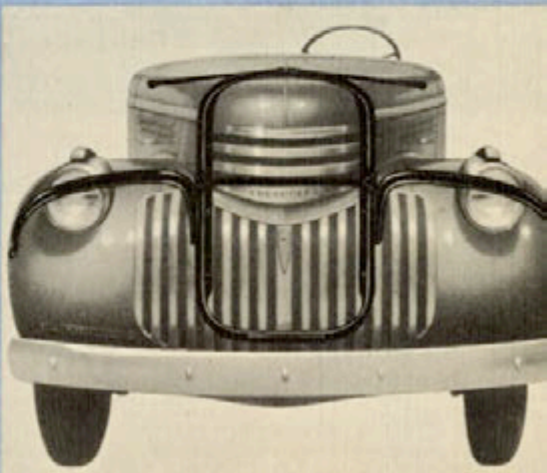

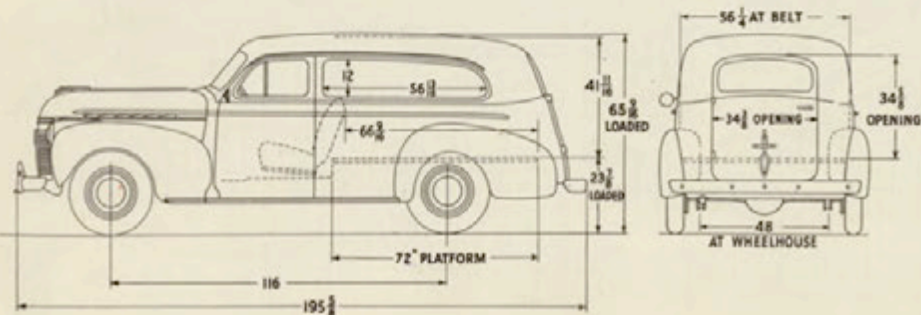
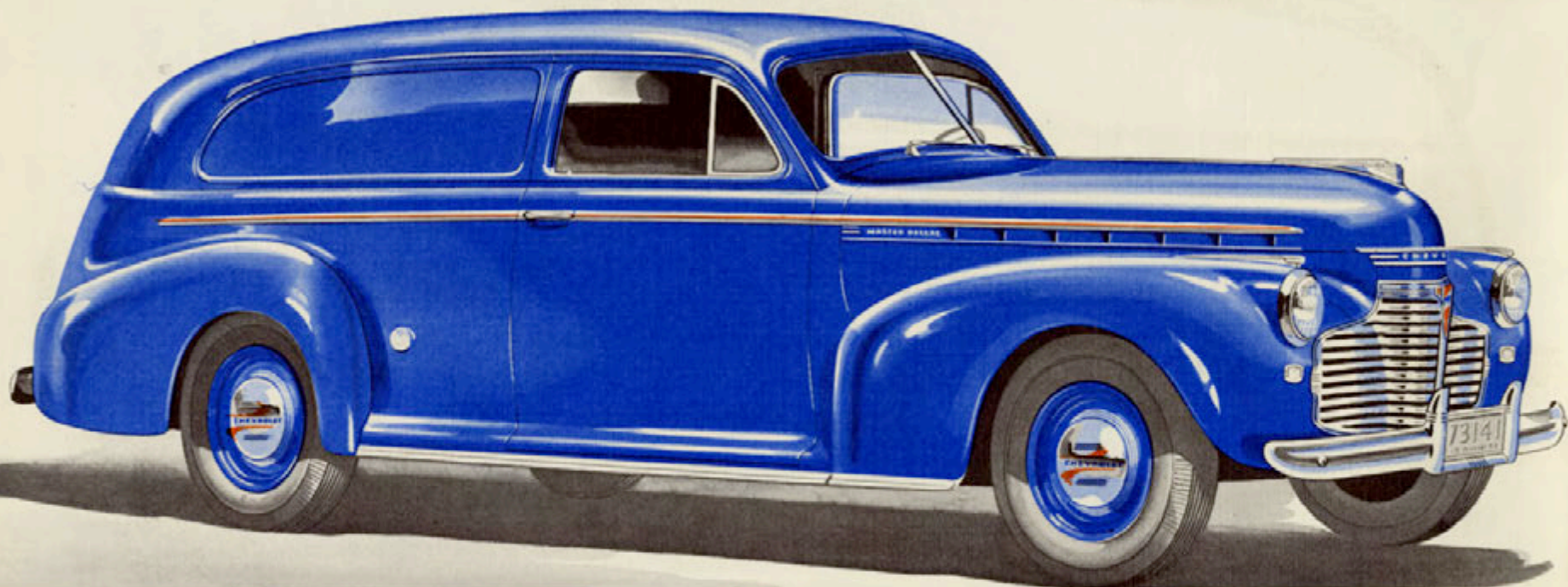

SEDAN DELIVERY—116-inch Wheelbase

Special all-steel streamlined body mounted on 1941 Chevrolet passenger car chassis . . . Ideal for use in operations requiring easy riding, speedy delivery, easy handling and economy . . . Special features include Knee-Action, hydraulic shock absorbers front and rear, and vacuum-power gearshift. Coupe Pick-up also available on this chassis.

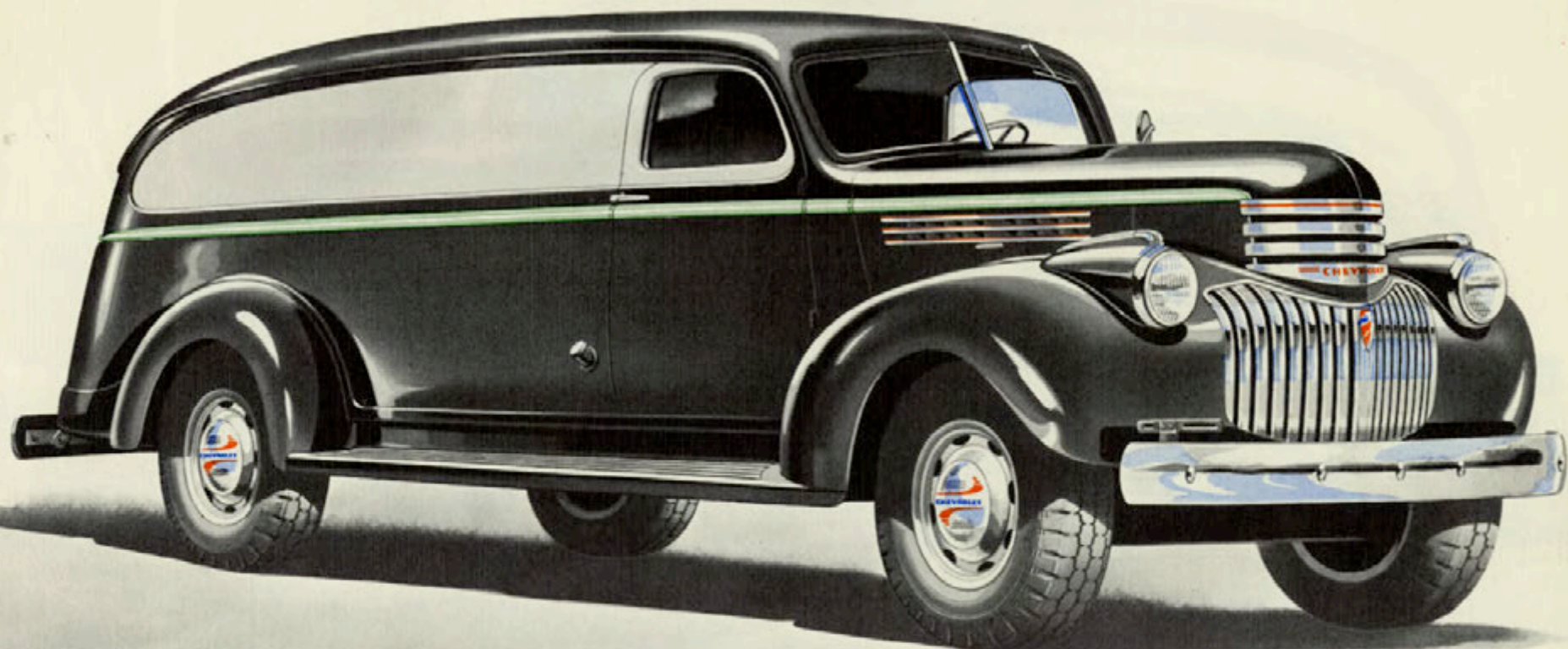

THREE-QUARTER-TON LONG WHEELBASE PANEL

134½-inch Wheelbase

Designed to provide the user with increased cubic-foot load capacity and to operate at virtually no increase in cost over that of the standard 125¼-inch wheelbase ¾-Ton model . . . Chassis equipped with four-speed transmission, special rear springs and larger rear brake drums than standard model (For body details, see page 32.) This body is also available on 134½-inch wheelbase, Heavy Duty chassis.

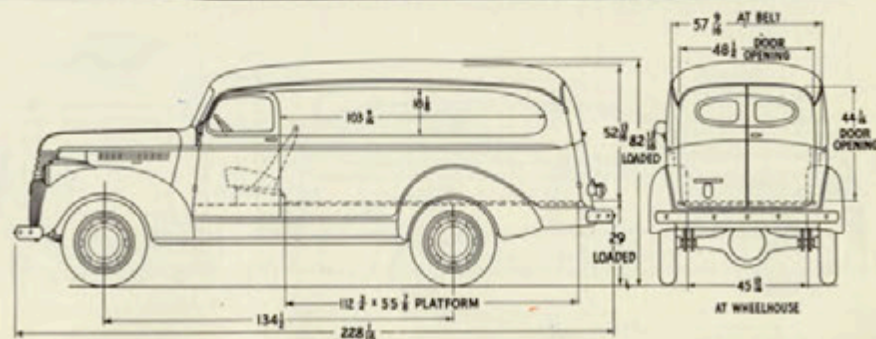

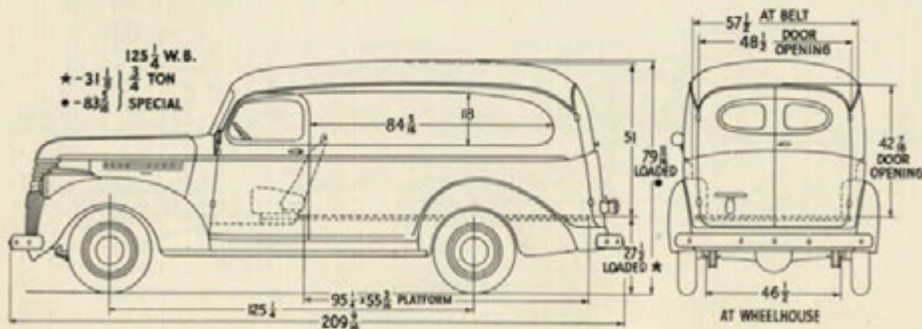
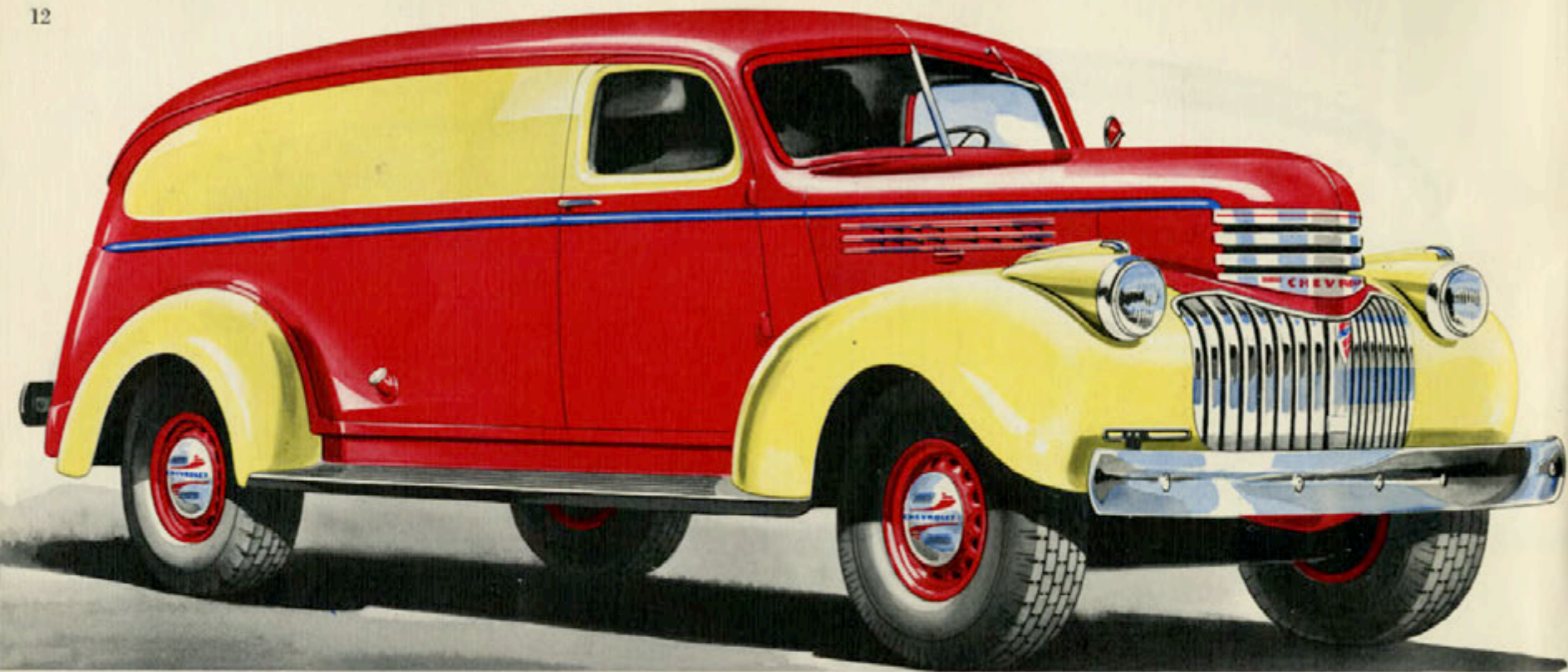

THREE-QUARTER-TON PANEL—125 $\frac{1}{4}$ -inch Wheelbase

Combines advantages of distinctive styling with unusual spaciousness in load compartment . . . Continuous sign panel . . . Insulated roof and side panels . . . Seat adjustable over range of three inches . . . Latex-impregnated hair in seat cushion . . . Steel skid strips protect wood floor . . . Dome light in load compartment (For body details, see page 32.) This body type is also furnished with heavy duty equipment as $\frac{3}{4}$ -Ton Special.

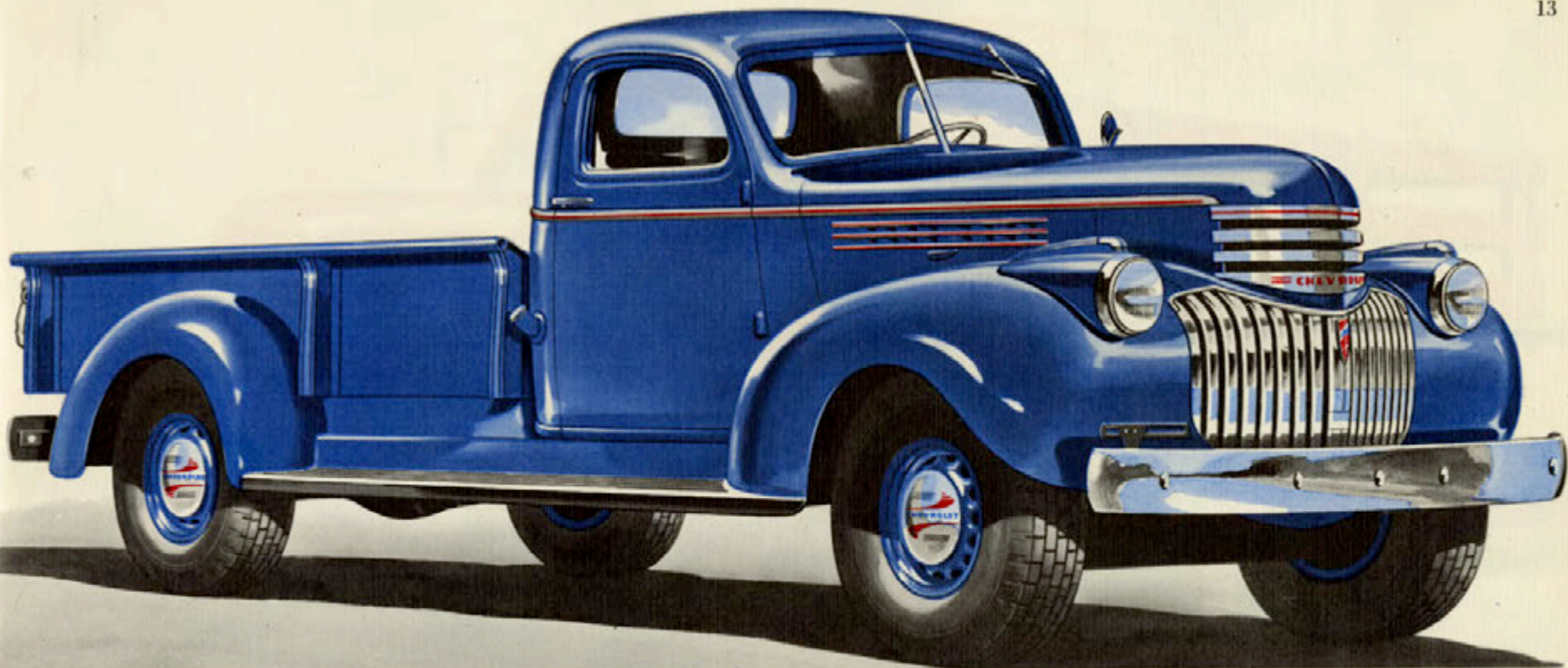

THREE-QUARTER-TON PICK-UP 125 $\frac{1}{4}$ -inch Wheelbase

Standard Chevrolet streamlined all-steel cab (see page 30) . . . Combines unusually large load space with speedy and economical operation . . . Wide flare-boards reinforced with rigid rolled edges . . . Skid strips in floor facilitate loading and prolong life of body (For body details, see page 34.) This body type is also furnished with heavy duty equipment as $\frac{3}{4}$ -Ton Special.

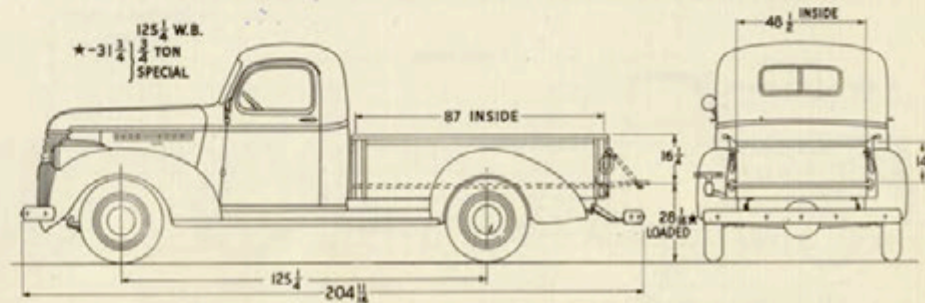

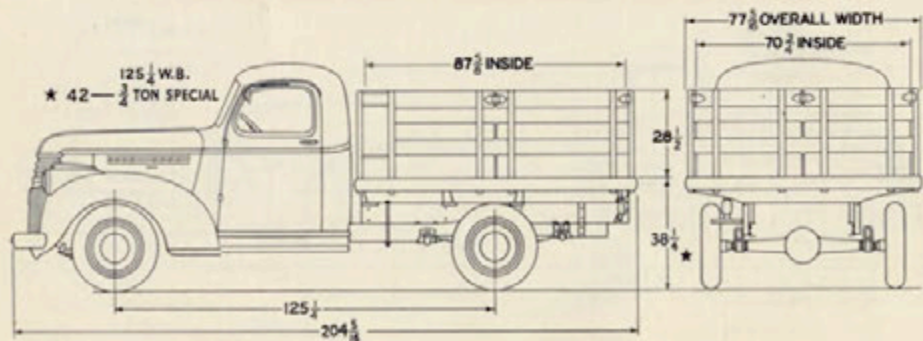
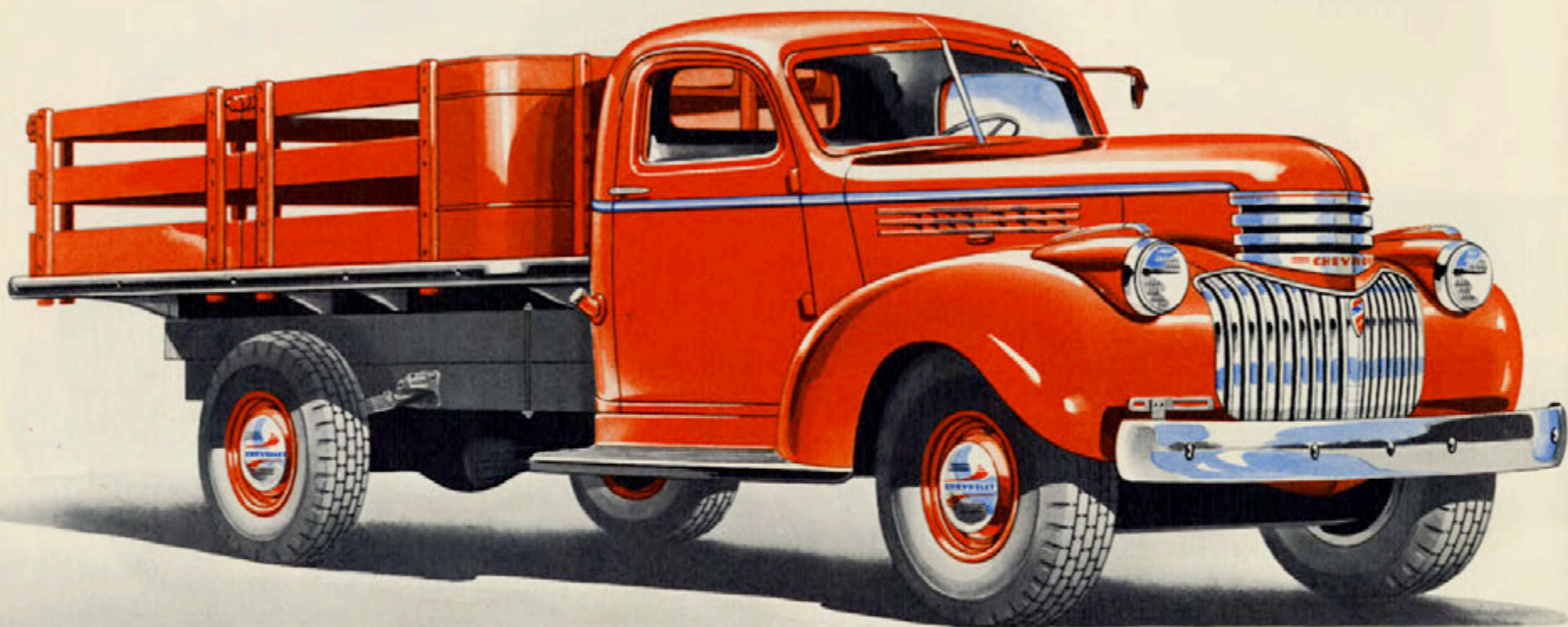

THREE-QUARTER-TON STAKE

125 $\frac{1}{4}$ -inch Wheelbase

Large loading platform adapted for hauling merchandise that bulks large for its weight . . . Interlocking stake sides supported securely in reinforced steel pockets, protected by rub-rail . . . Slats fastened to stakes with flush bolts (For body details, see page 35.) This body type is also furnished with heavy duty equipment as $\frac{3}{4}$ -Ton Special.

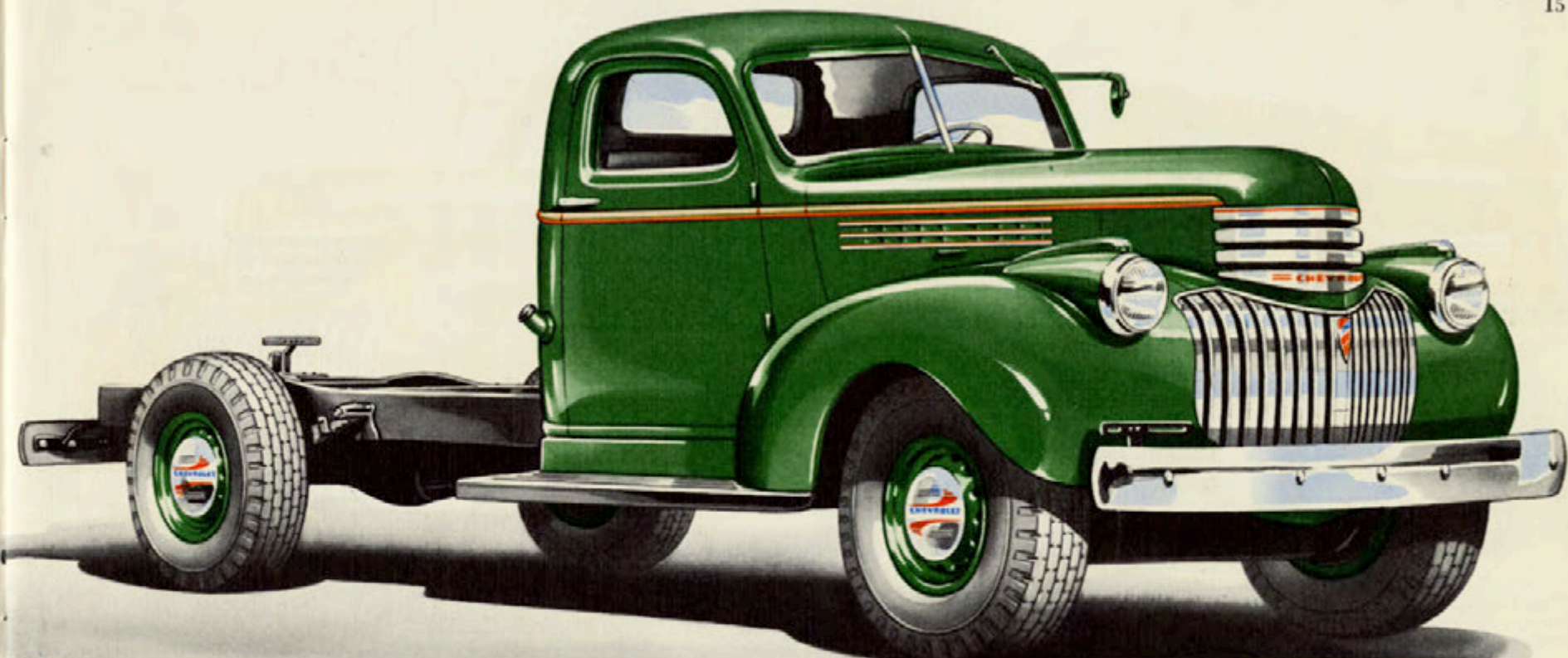

THREE-QUARTER-TON CHASSIS WITH CAB

125 $\frac{1}{4}$ -inch Wheelbase

The $\frac{3}{4}$ -Ton chassis is designed for easy handling and speedy operation in the field between the Light Delivery and Heavy Duty models . . . Has a three-speed Syncro-Mesh transmission (four-speed transmission available at slight extra cost) . . . 18-gallon fuel tank in cab . . . Additional heavy duty equipment also is available on this chassis as $\frac{3}{4}$ -Ton Special.

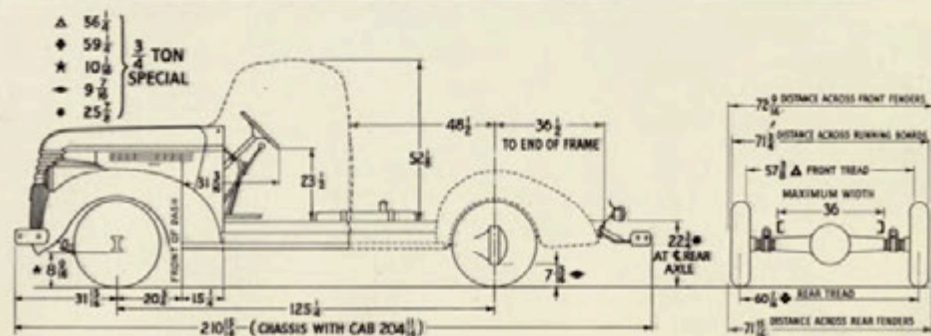

Three-Quarter-Ton and Three-Quarter

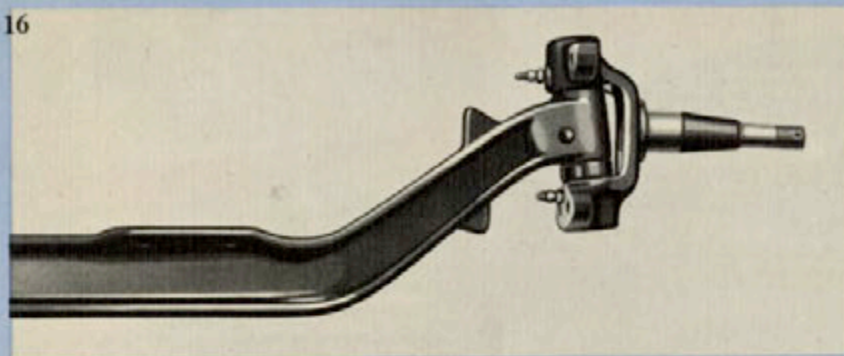

Front Axle—I-beam type, increased 25 per cent in strength for 1941, with larger and stronger king pins, steering spindle and front wheel inner bearing.

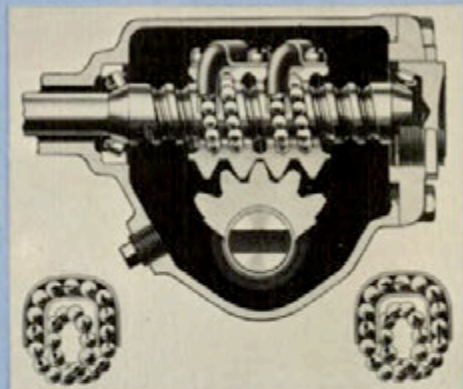

Hotchkiss Drive—The two short propeller shafts are supported by rubber-insulated hangers.

Steering—Ball bearing worm and nut steering gear, new for 1941, promotes ease of steering and durability. Sixty-six bearing balls roll continuously in two spiral races.

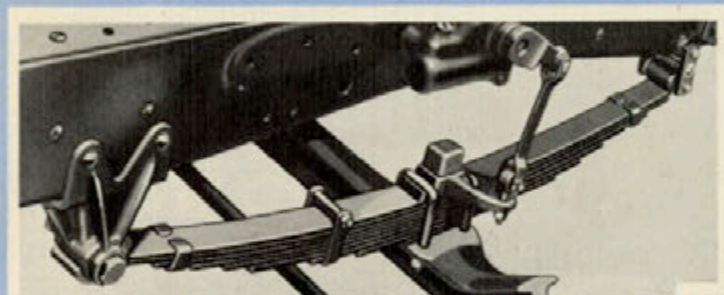

Front Springs—The spring is flat under load to give the best steering and riding action. Reduced spring rate for 1941 to effect better riding qualities.

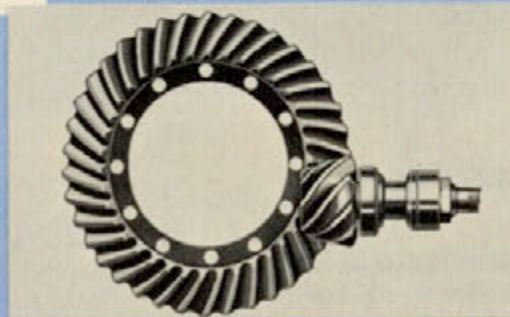
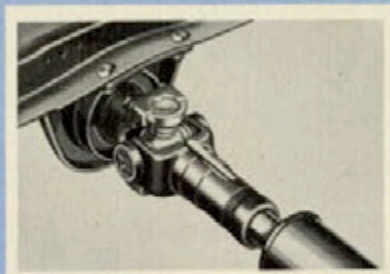

Rear Axle—Hypoid drive gears give a new maximum of strength and durability. Differential bearings, with higher load capacity, are barrel roller type.

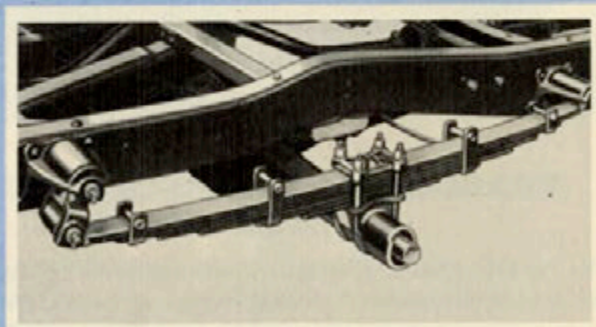

Rear Springs—New two-stage springs, with reduced rate, for easy ride with either light or heavy load.

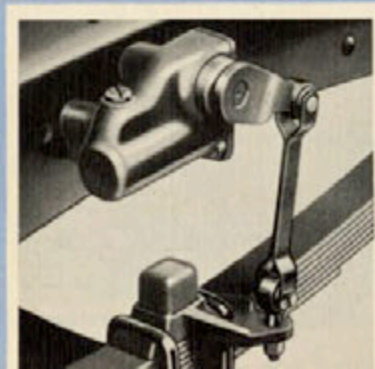

Shock Absorbers—Delco hydraulics, single-acting, are used front and rear on the $\frac{3}{4}$ -Ton and at the front of the $\frac{3}{4}$ -Ton Special.

CHEVROLET

Ton Special Chassis Features

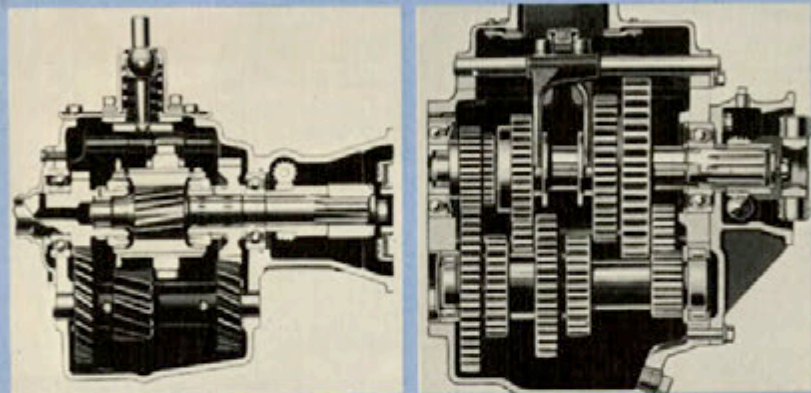

Transmission—The Syncro-Mesh three-speed transmission (left), with all helical carburized gears and with anti-friction bearings for forward speed gears, is standard on the $\frac{3}{4}$ -Ton model. The Chevrolet four-speed transmission, a heavy duty unit, is used in the $\frac{3}{4}$ -Ton long wheelbase model, and may be had in the $\frac{3}{4}$ -Ton model at slight extra cost.

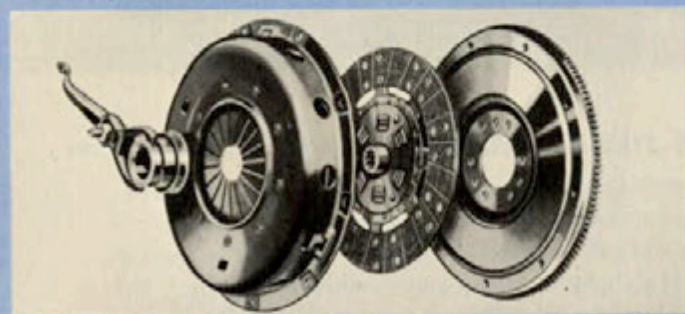

Diaphragm Spring Clutch—A single disc spring is used instead of multiple coil springs, resulting in unusually light pedal pressure, reduced weight, and longer clutch lining life due to even pressure distribution. Quieter operation in high gear under heavy loads.

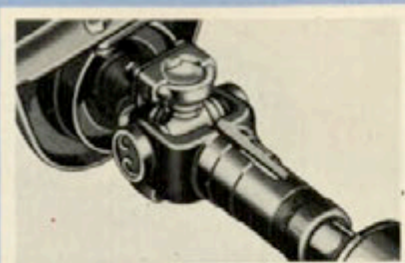

Universal Joints—Two needle-bearing universal joints are used in the $\frac{3}{4}$ -Ton, and three in the $\frac{3}{4}$ -Ton long wheelbase models.

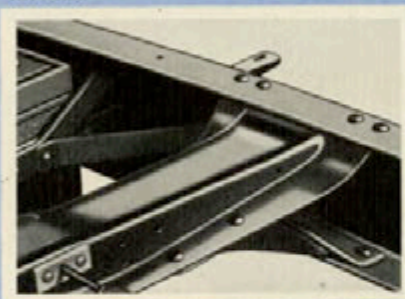

Frame—Channel-section side-rails and flanged or box-section cross-members, with "alligator jaw" attachments, make up a truck frame of extraordinary strength.

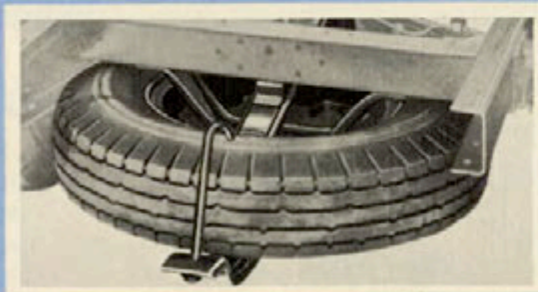

Mono-Rail Tire Carrier—The spare wheel is securely mounted, yet easily accessible.

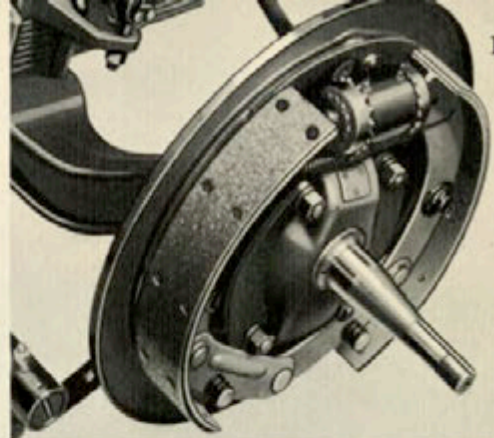

Hydraulic Brakes—Chevrolet's exclusive linkage assures positive action, and full contact of the self-aligning brake shoes with the drum.

Stabilized Front End—The radiator, front fenders and hood are rigidly supported by a massive framework of steel supported on a centered rubber mounting.

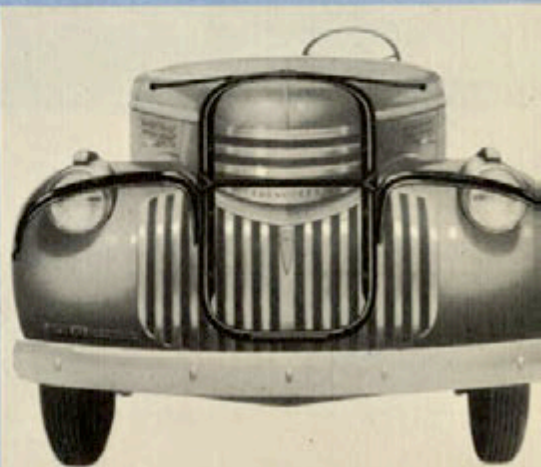

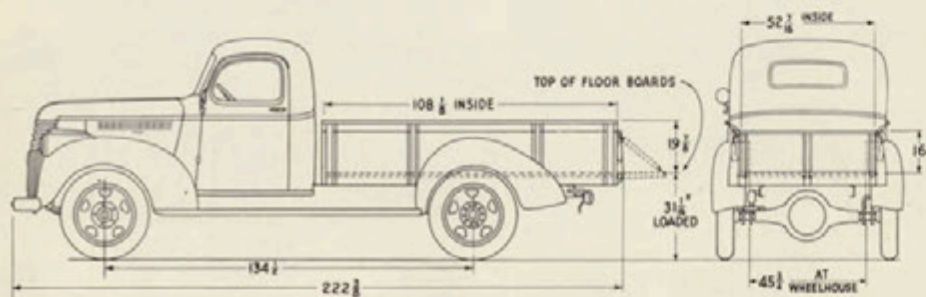
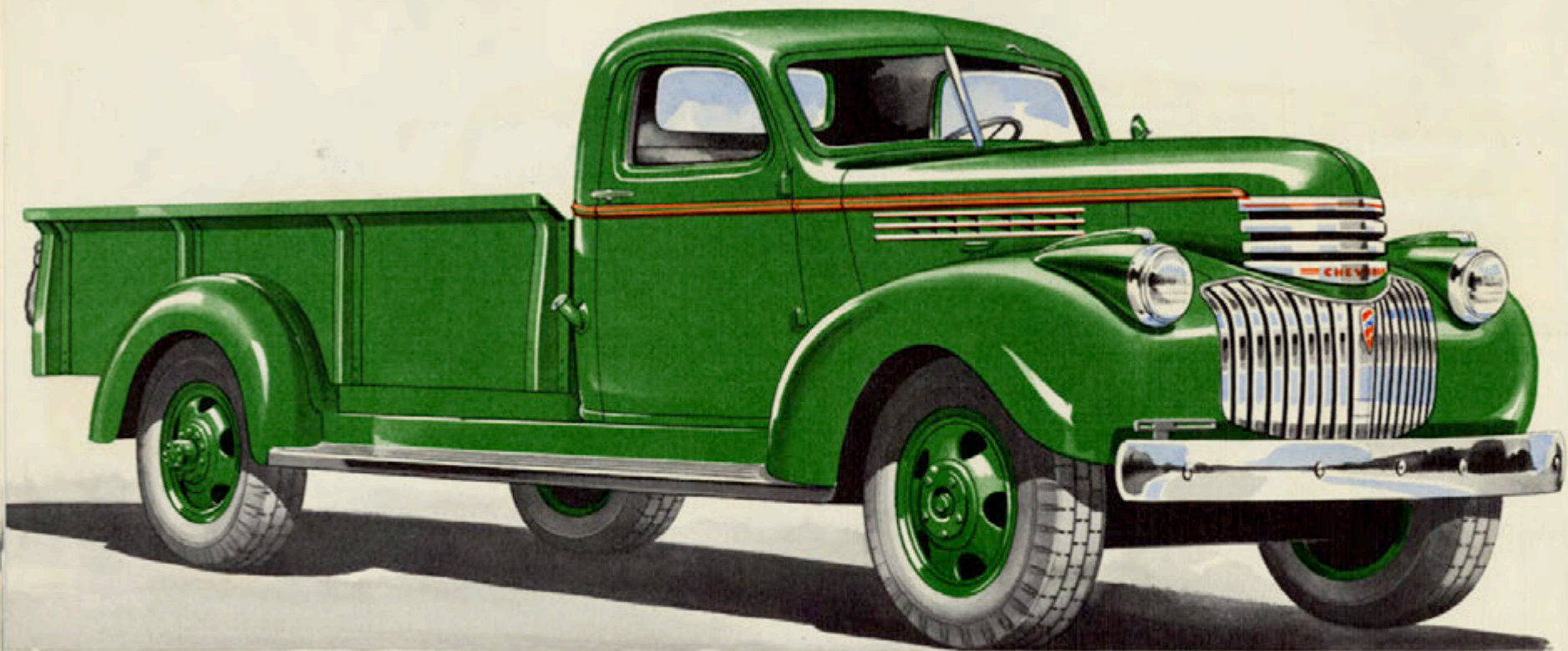

HEAVY DUTY PICK-UP—134 $\frac{1}{2}$ -inch Wheelbase

A massive model of innumerable uses and wide application in operations requiring large capacity . . . The edges of the wide flare-boards are formed in rigid triangular sections . . . Skid strips in floor add to durability and ease of loading (For body details, see page 34.)

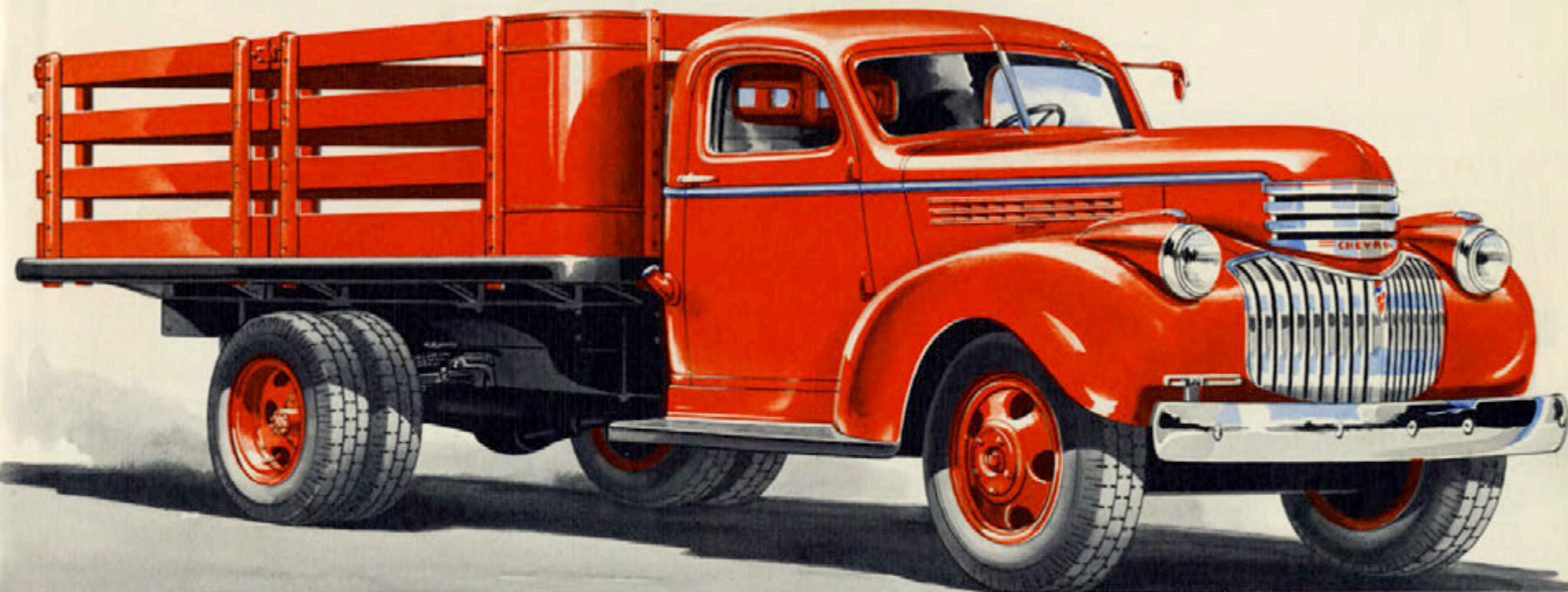

HEAVY DUTY STAKE — 134½-inch Wheelbase

A large-capacity model especially adapted to operations involving heavy loads . . . Sturdy, interlocking stake sides carried in reinforced steel pockets, protected by a strong rub-rail . . . Slats are fastened to stakes with flush bolts (For body details, see page 35.)

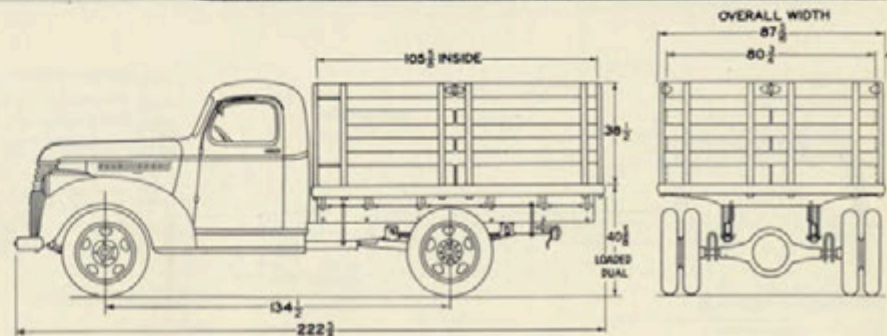

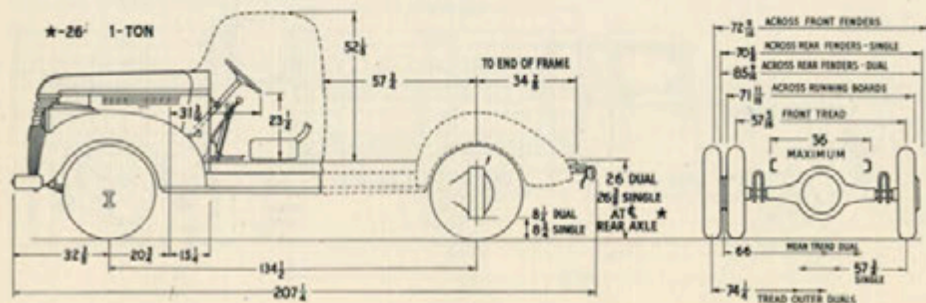
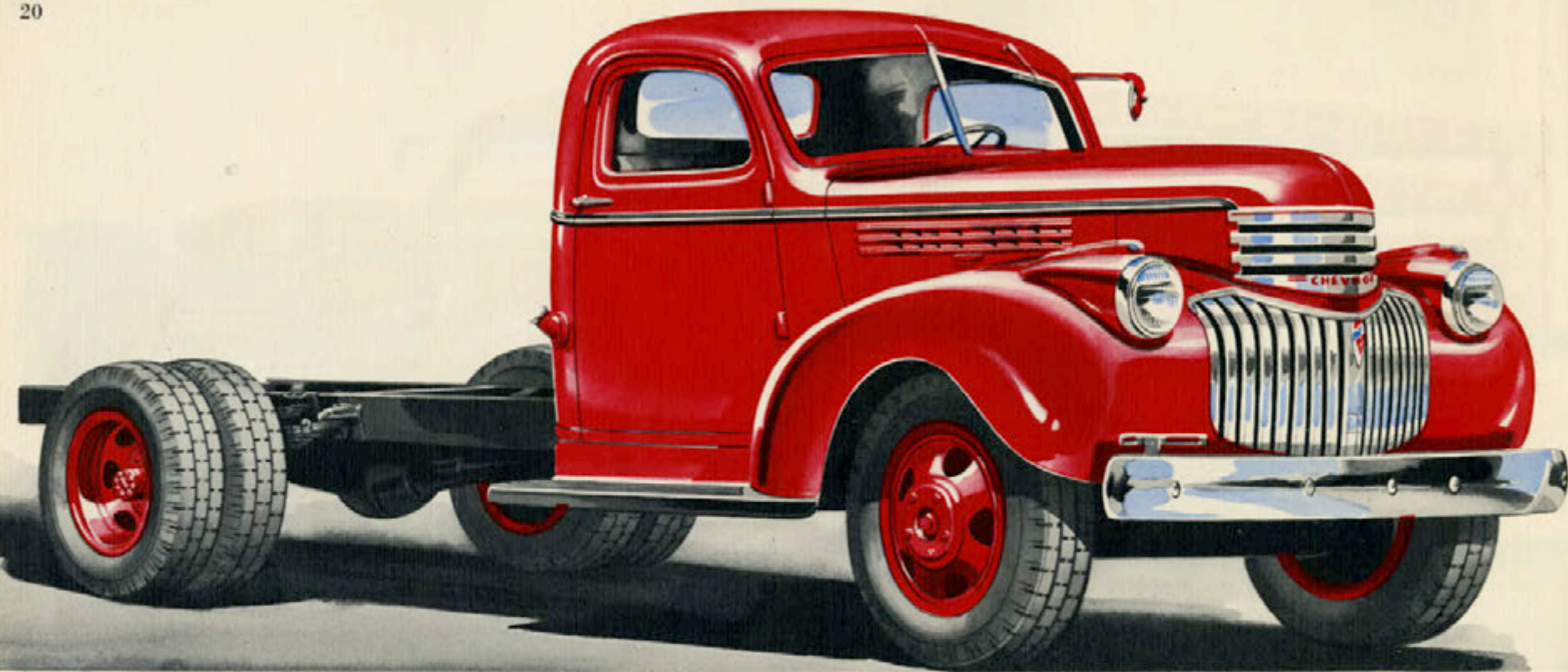

HEAVY DUTY CHASSIS WITH CAB

134 1/2-inch Wheelbase

The Heavy Duty chassis incorporates all the advanced features of truck construction that have made Chevrolet trucks the leaders in the industry year after year . . . It is equipped with a four-speed sliding gear transmission with provision for power take-off . . . 18-gallon fuel tank in cab (For details of chassis and cab, see pages 28, 29, and 30.) This chassis is also available with equipment for one-ton duty.

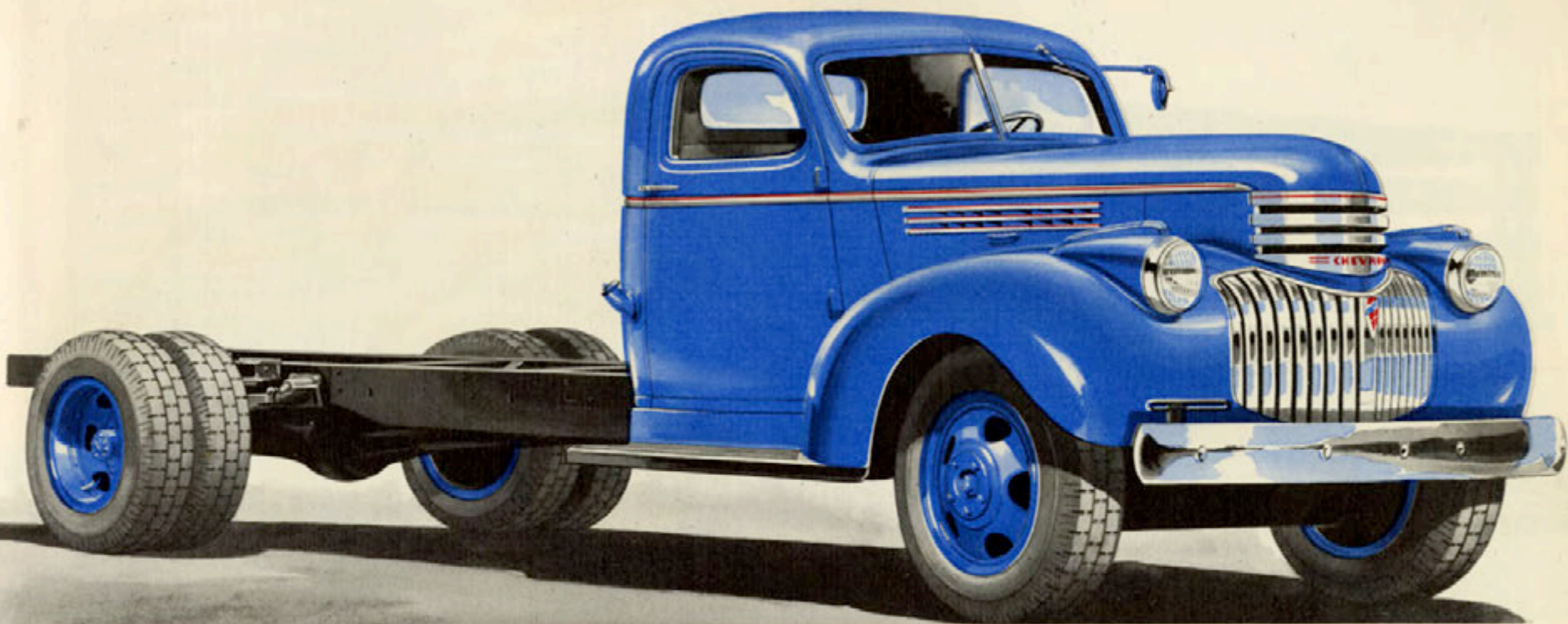

HEAVY DUTY CHASSIS WITH CAB

160-inch Wheelbase

Similar in construction and features to the 134½-inch Heavy Duty model illustrated on page 20 but providing greatly increased loading space . . . Chassis frame has one extra cross-member, or six in all . . . Special side-member reinforcing plates are standard equipment on all 160-inch wheelbase models (For details of chassis and cab, see pages 28, 29, and 30.)

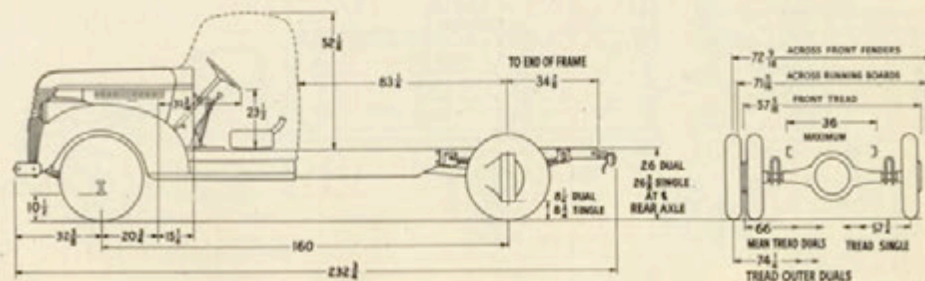

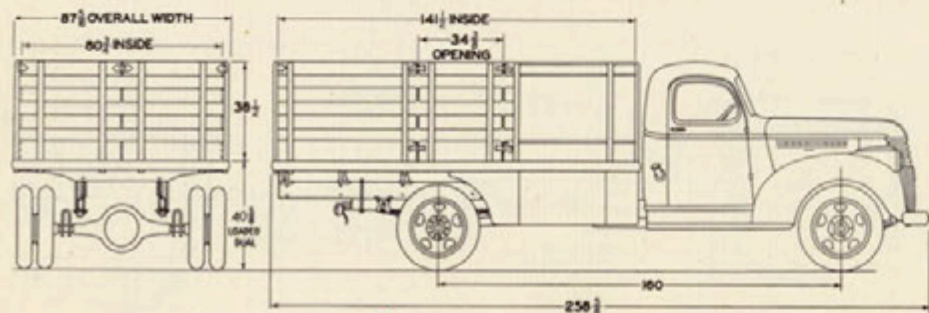
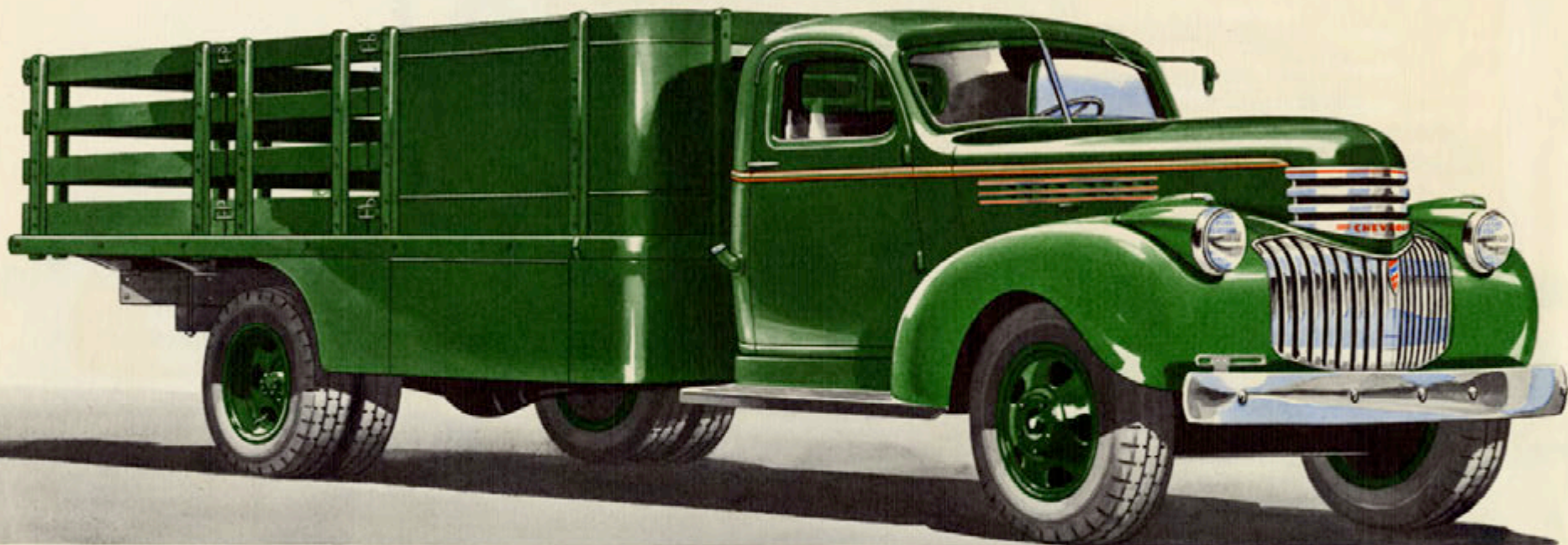

HEAVY DUTY DE LUXE STAKE—160-inch Wheelbase

An extra-sturdy stake model of rare distinction and extra utility . . . Solid advertising sign panel . . . Underbody and chassis concealed by deep skirt from cab to rear wheels . . . Spacious compartment suitable for tools, tarpaulins, etc., in skirt on right side of truck, with concealed opening . . . Stake pockets protected by sturdy rub-rail . . . Slats fastened to stakes with flush bolts (For details of chassis and cab, see page 35.)

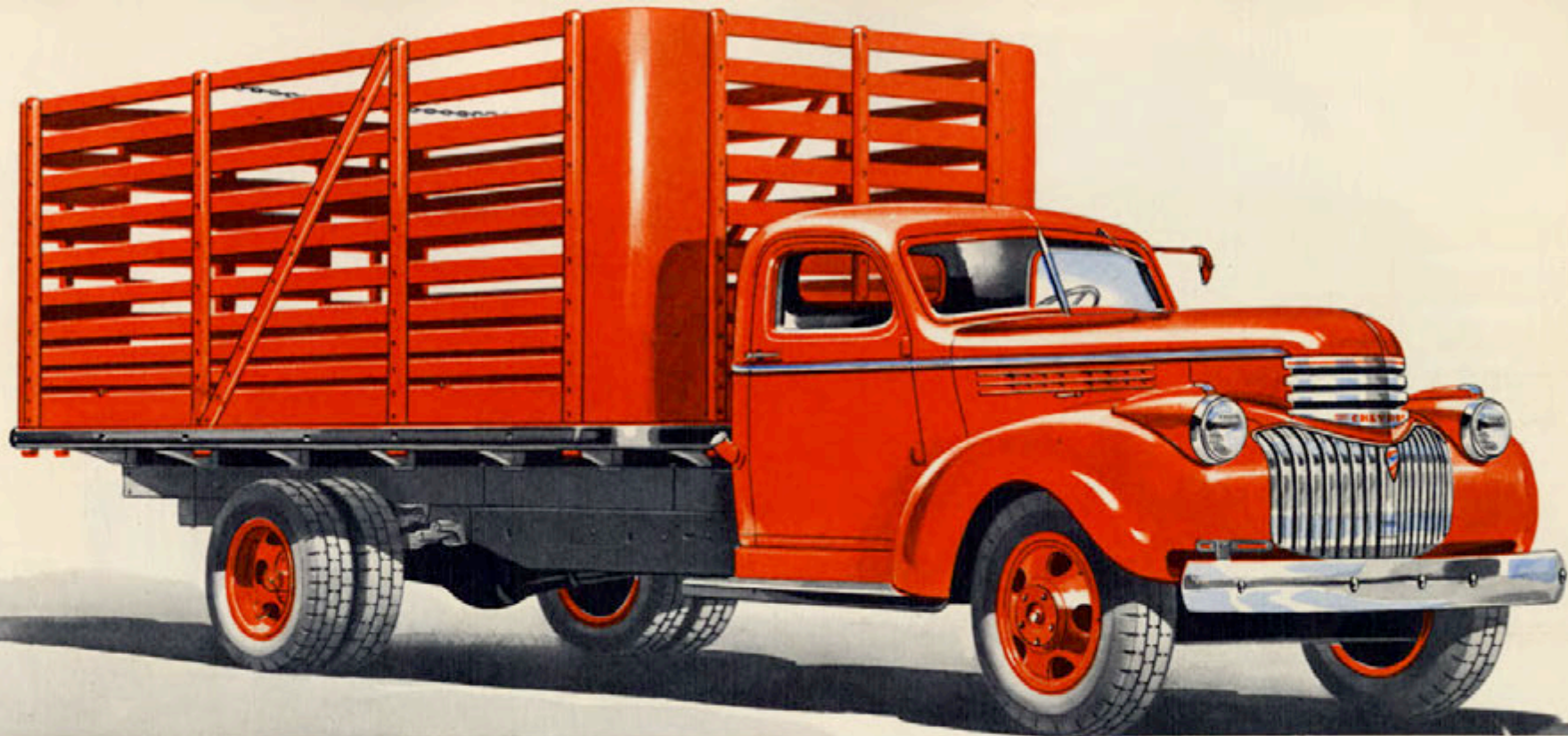

HEAVY DUTY HIGH RACK—160-inch Wheelbase

Specially designed for the transportation of livestock, completely protected from injury . . . Safety floor and rack . . . Slats fastened to stakes with flush bolts . . . Divided end-gate slides to either side to facilitate loading and insure safety; sliding sections provided with center control lock . . . The easily-removable racks have steel corner reinforcements (For details of chassis and cab, see page 35.)

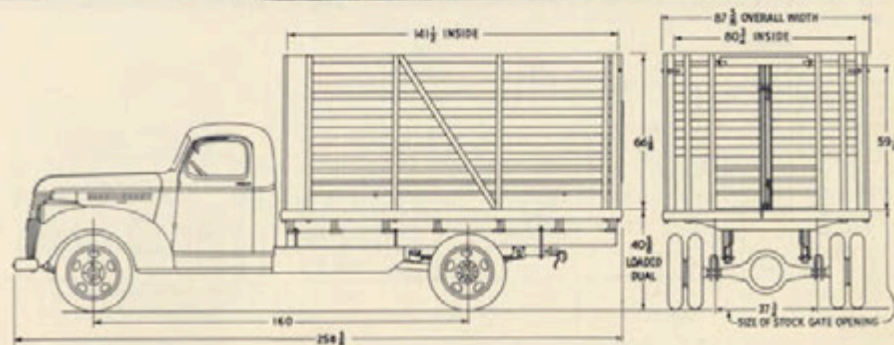

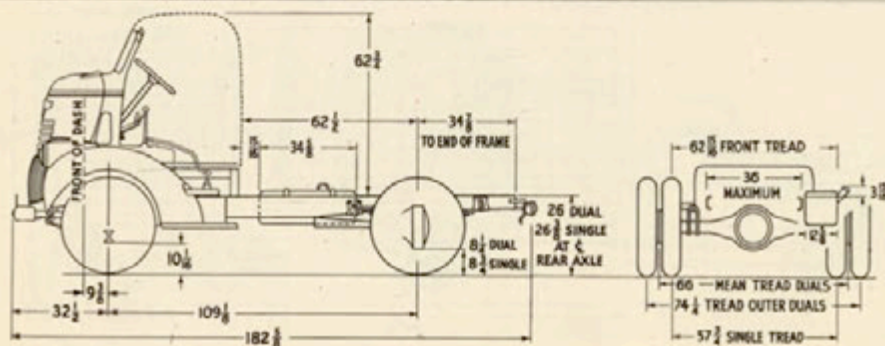
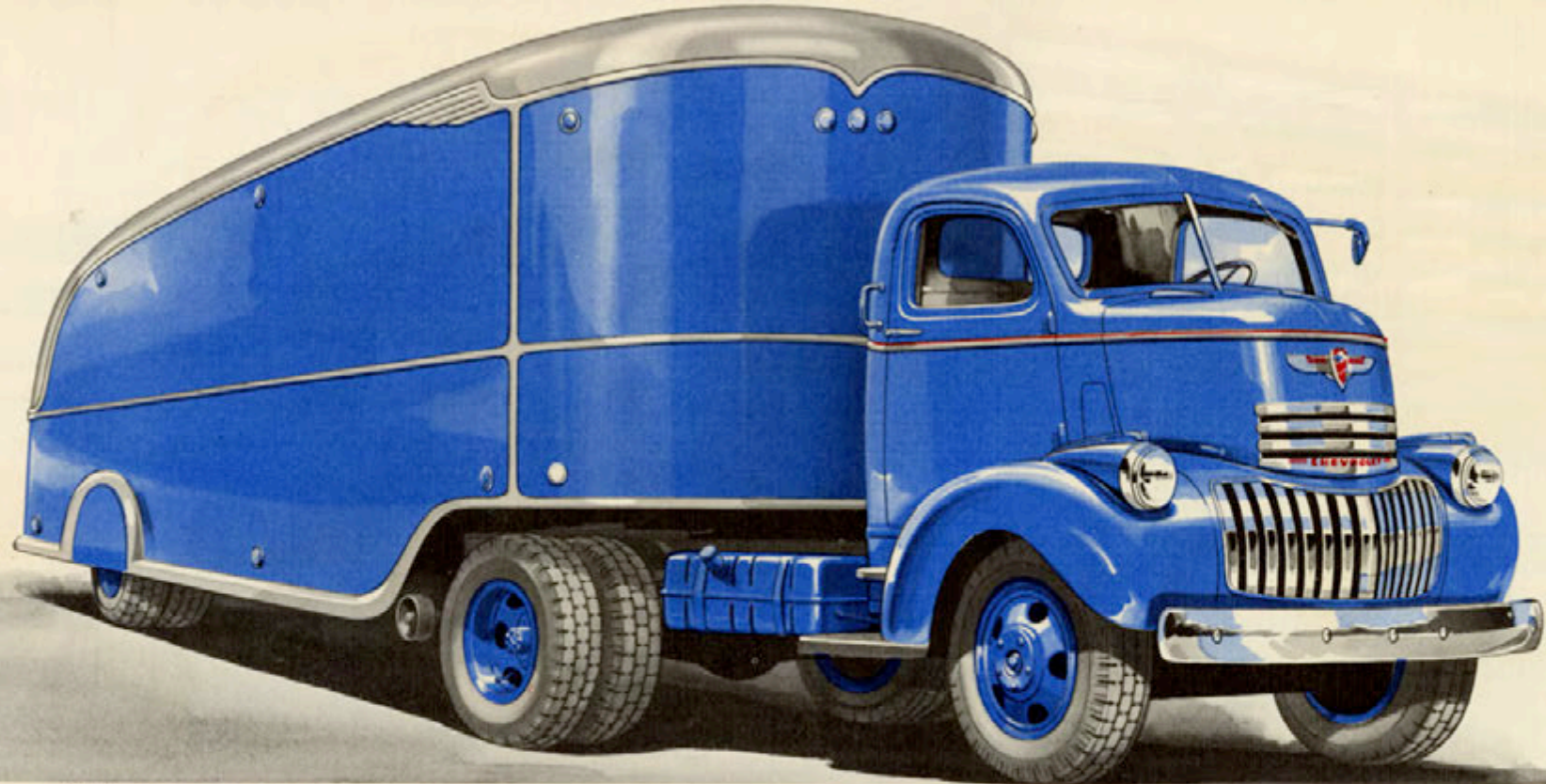

CAB-OVER-ENGINE UNIT FOR TRAILER OPERATION — 109 $\frac{1}{8}$ -inch Wheelbase

Cab and chassis designed and built by Chevrolet . . . Unusually spacious cab with full-width, single-cushion seat (50 inches wide) riding three men in comfort . . . Two side ventilators in cab . . . Extra-wide door opening . . . Special front end, including axle, wheel bearings, springs and steering. Special bodies are available through leading manufacturers and distributors (For details of chassis and cab, see page 31.)

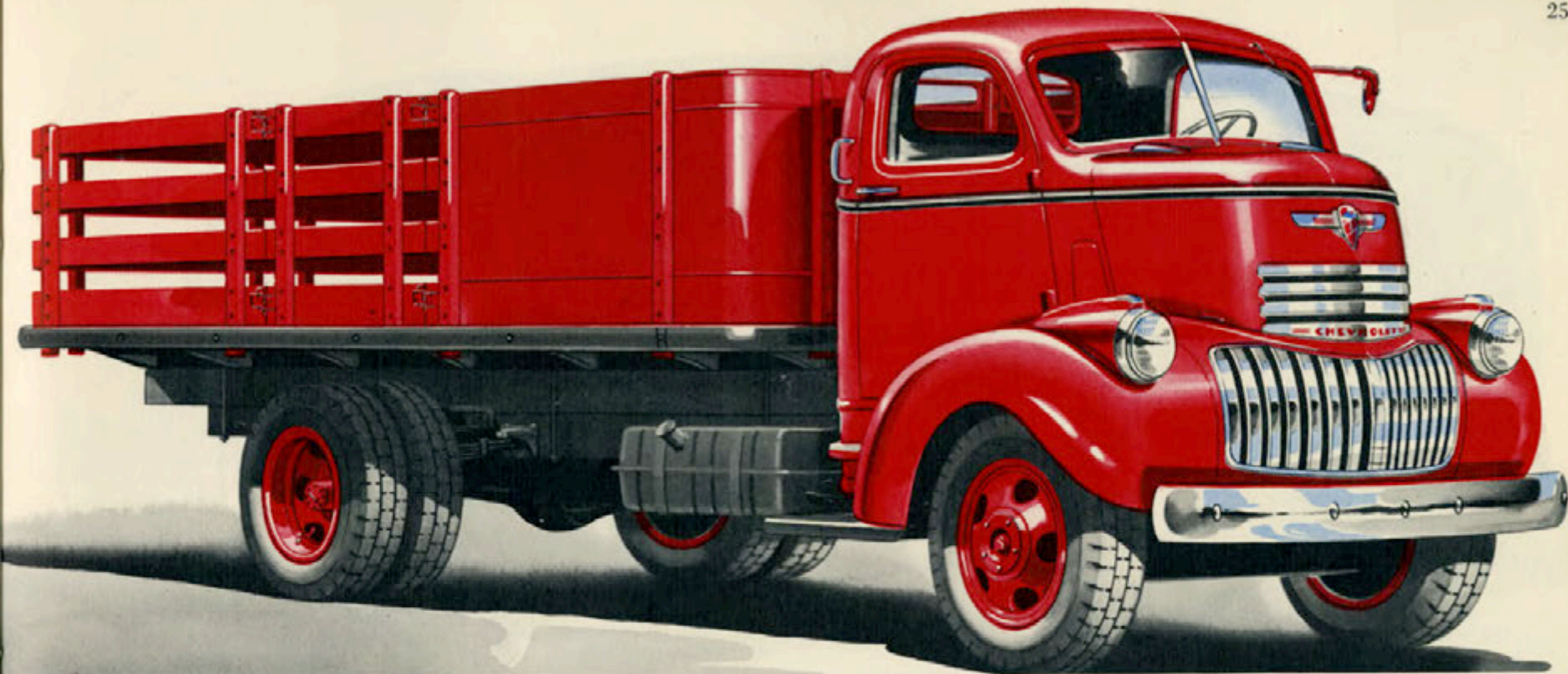

CAB-OVER-ENGINE STAKE—132 $\frac{5}{8}$ -inch Wheelbase

Cab, chassis and body designed and built by Chevrolet . . . Cab and chassis incorporate all features listed in description of Cab-Over-Engine Trailer unit on page 24 . . . Stake body is of standard Chevrolet construction, featuring heavily reinforced floor, sturdy support of stake sides in reinforced steel pockets, extra strong rub-rail, and flush bolt fastening of slats to stakes (For details of chassis and body, see pages 31 and 35.)

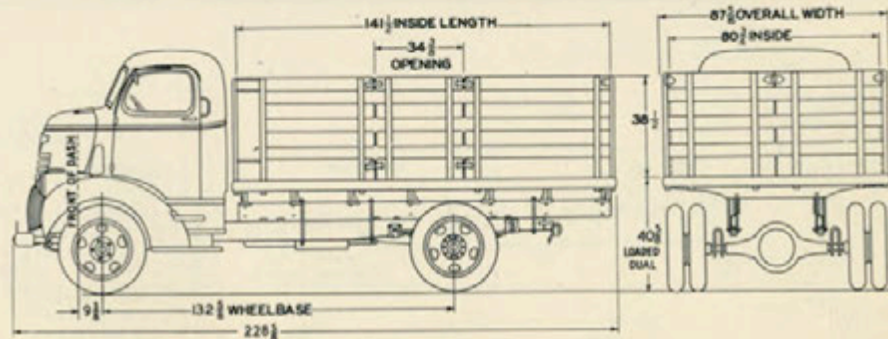

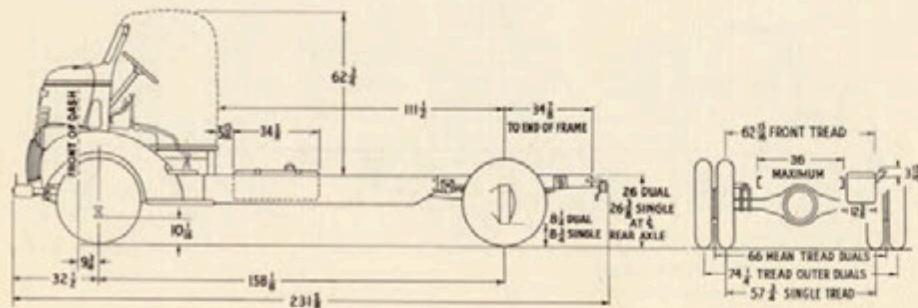
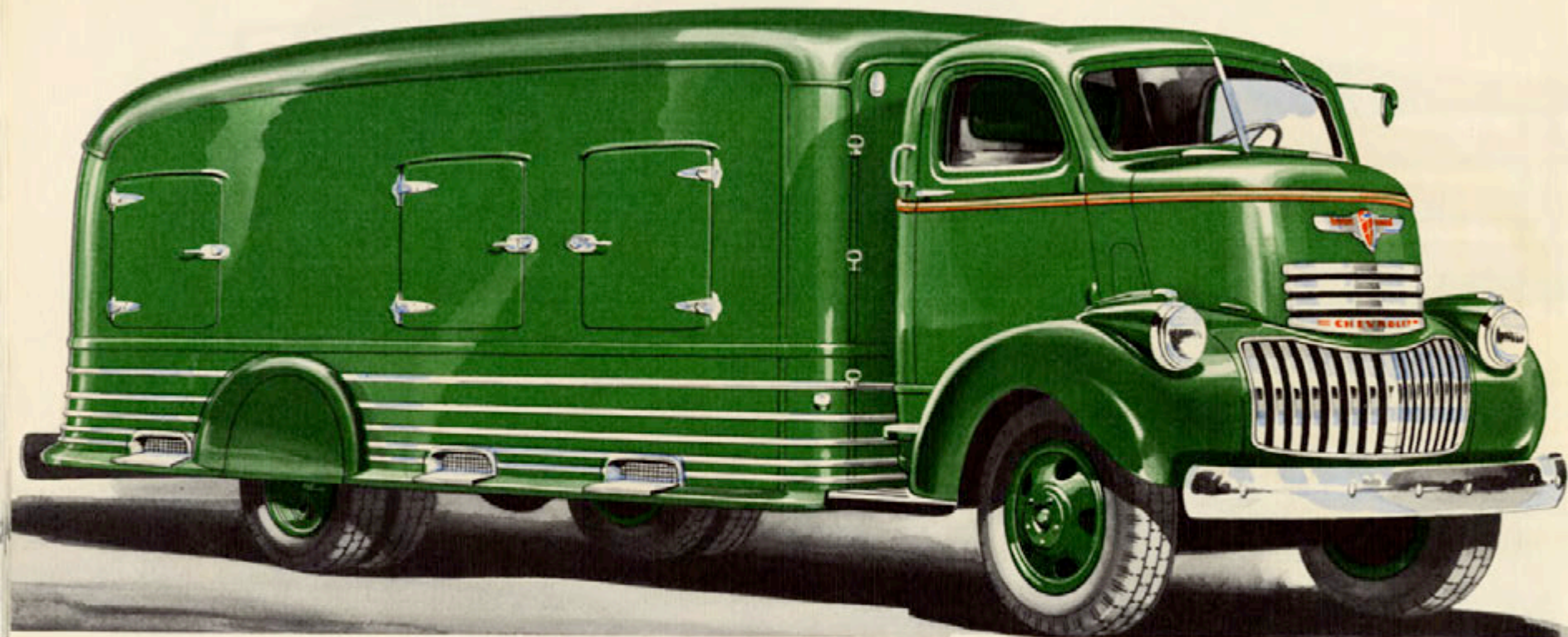

CAB-OVER-ENGINE FOR EXTRA-LONG SPECIAL BODIES—158 $\frac{1}{8}$ -inch Wheelbase

Cab and chassis completely designed and built by Chevrolet . . . Extra-long frame provides maximum space for special bodies without excessive over-all length . . . Ease of handling maintained by relatively short wheelbase compared with length of body . . . Special front end, including axle, wheel bearings, springs and steering . . . Special bodies available through manufacturers and distributors (For details of chassis and cab, see pages 30 and 31.)



SCHOOL BUS CHASSIS

160-inch and 195 $\frac{1}{8}$ -inch Wheelbases

Typical Chevrolet construction throughout, adapted especially to meet the most exacting requirements of safety and comfort . . . Chassis frame of special extra-heavy side-rails with extra wide flanges . . . Eight cross-members . . . Powered by Chevrolet's Heavy Duty truck engine governed to maximum road speed of 35 miles per hour . . . High-capacity hydraulic brakes . . . Bodies are available through leading manufacturers (For chassis and engine features, see pages 28, 29, 36, and 37.)

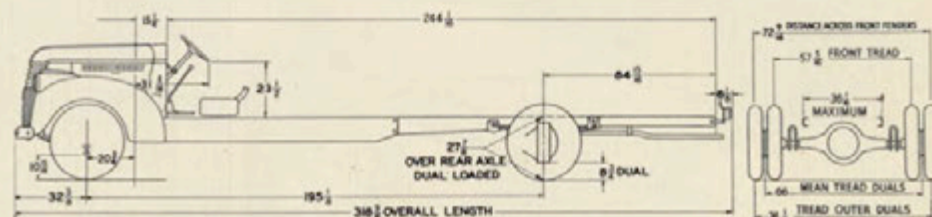

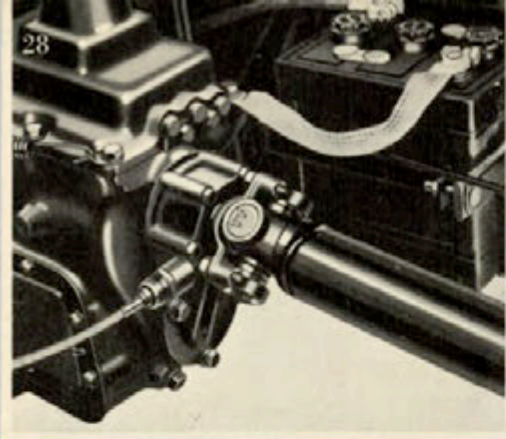

Transmission—The Chevrolet four-speed transmission, a heavy duty unit, with provision for a power take-off, is used in all Heavy Duty models. All speeds except reverse are through anti-friction bearings.

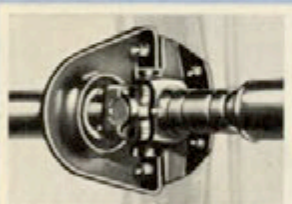

Universal Joints
—Three needle-bearing universal joints are used in the propeller shafts.

Front Springs—The spring is nearly flat under load to give the best steering and riding action. The seven-leaf spring has been increased 4 inches in length and $\frac{1}{2}$ -inch in width (40 inches x 2 inches) for 1941.

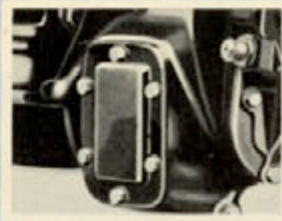
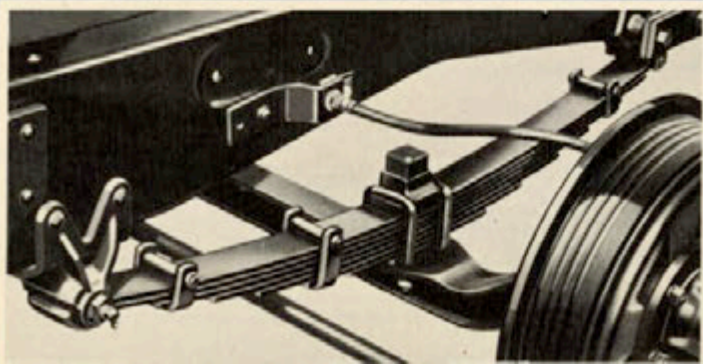

Power Take-off—Removal of a special cover plate from the transmission permits the mounting of a power take-off, driven by the counter-shaft.

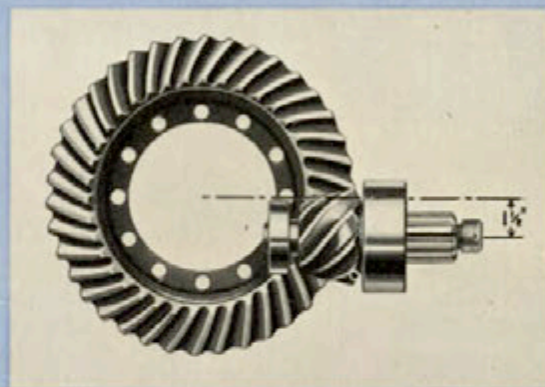

Rear Axle—Hypoid drive gears give a new maximum of strength and durability. The axle is the full-floating type. Ratio, 6.17:1, 5.43:1.

Rear Springs—One inch longer for 1941. Now 46 inches, by $2\frac{1}{2}$ inches wide. Special rear-spring combinations are available at extra cost.

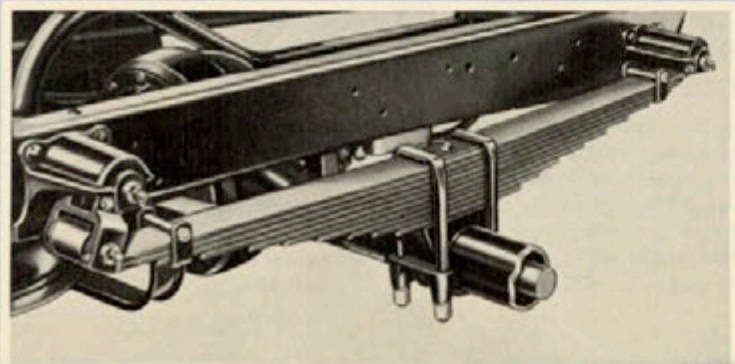

Heavy Duty

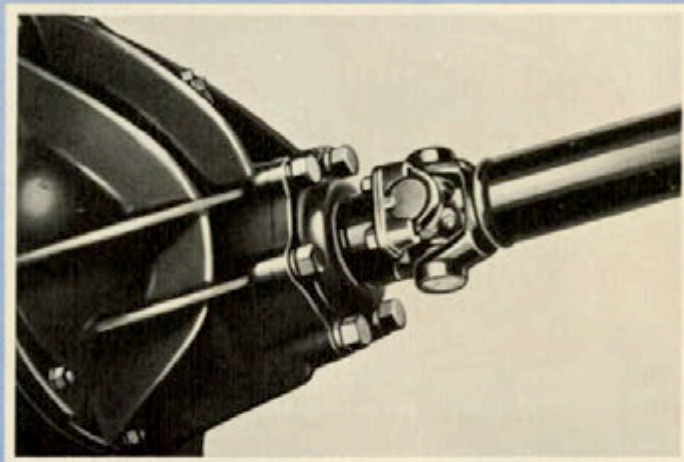

Hotchkiss Drive—The two short propeller shafts are supported by rubber-insulated hangers.

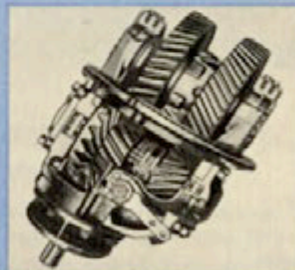

Two-Speed Rear Axle—Greatly increases the range of power and speed ratios. (Optional at an extra charge.)

CHEVROLET

Chassis Features

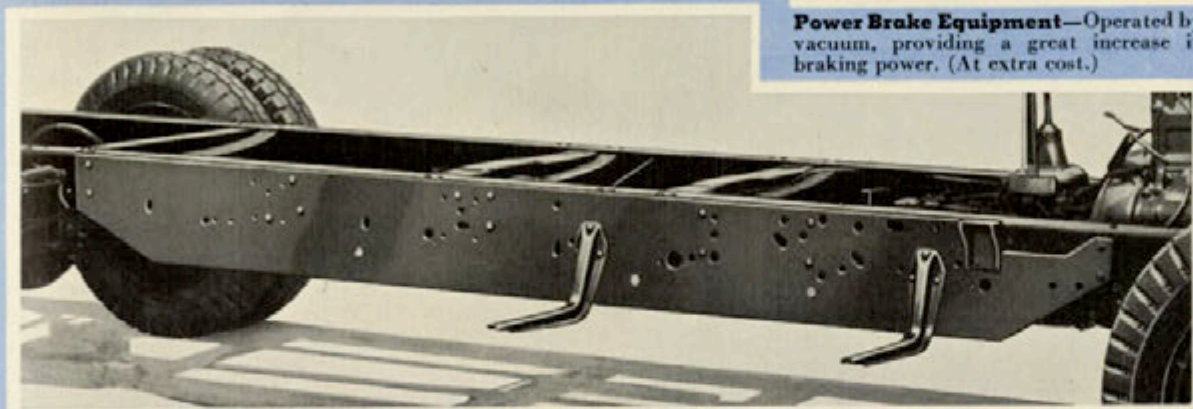

Frame—Channel-section side-rails and flanged or box-section cross-members, with "alligator jaw" attachments, make up a truck frame of extraordinary strength. Reinforcement plates are standard equipment on the 158 $\frac{1}{2}$, 160 and 195 $\frac{1}{2}$ -inch wheelbase chassis.

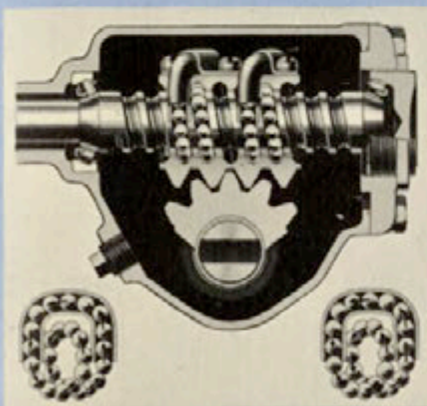

Steering—Ball bearing worm and nut steering gear, new for 1941, promotes ease of steering and durability. Sixty-six bearing balls roll continuously in two spiral races.

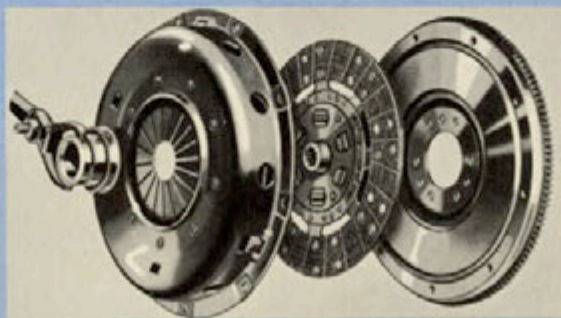

Diaphragm Spring Clutch—A single disc spring is used instead of multiple coil springs, resulting in unusually light pedal pressure, reduced weight, longer clutch lining life and quieter operation in high gear under heavy loads.

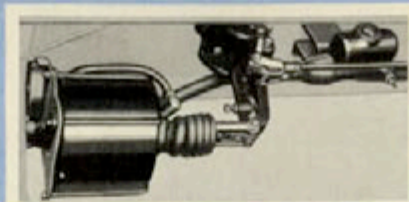

Power Brake Equipment—Operated by vacuum, providing a great increase in braking power. (At extra cost.)

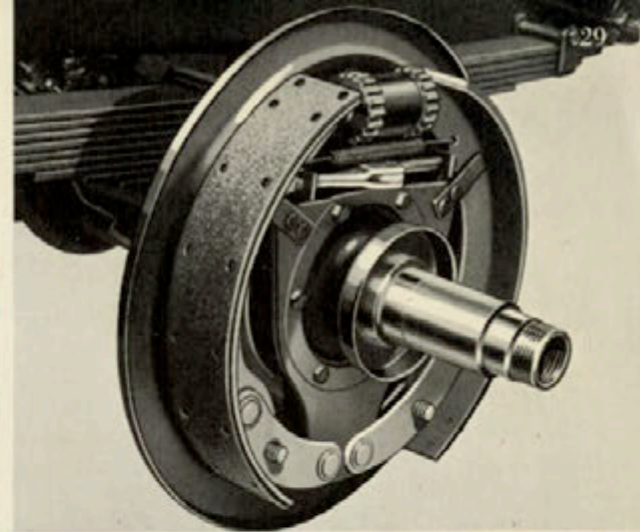

Hydraulic Brakes—Chevrolet's exclusive linkage assures positive action, and full contact of the self-aligning brake shoes with the drum.

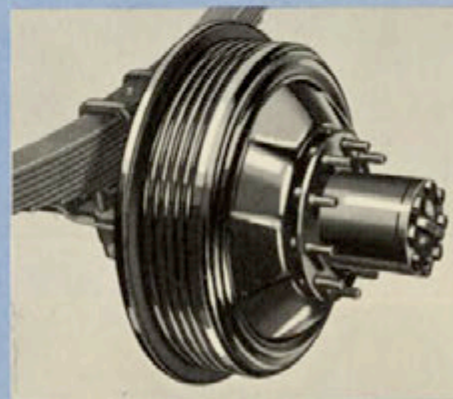

Brake Drums—Composite style. New 1941 linings with friction coefficient to match that of the new drums.

Features

OF THE CHEVROLET

All-Steel Truck Cab

Improvements that give important increases in comfort and convenience mark the new Chevrolet cab for 1941. The cab is $1\frac{1}{2}$ inches longer, which gives added leg room and permits the seat back to be sloped at an easier riding angle. The cab is all-steel, thoroughly insulated, and smoothly finished inside for good appearance and easy cleaning. The full-width seat cushion is formed of a latex-bound hair pad on resilient coil springs. (Genuine leather upholstery available at extra cost.) Adjustable windshield, windows with crank control, and improved cowl ventilator provide for full control of ventilation. Refueling is performed from the outside without requiring the driver to dismount or raise the seat cushion.

The detailed illustrations below show the heavily-insulated floor mat held down securely by fasteners set in the floor . . . the new window glass guard, a chromium channel fitted on the edge of the pane to prevent breakage . . . and the package compartment, fitted with a lock.

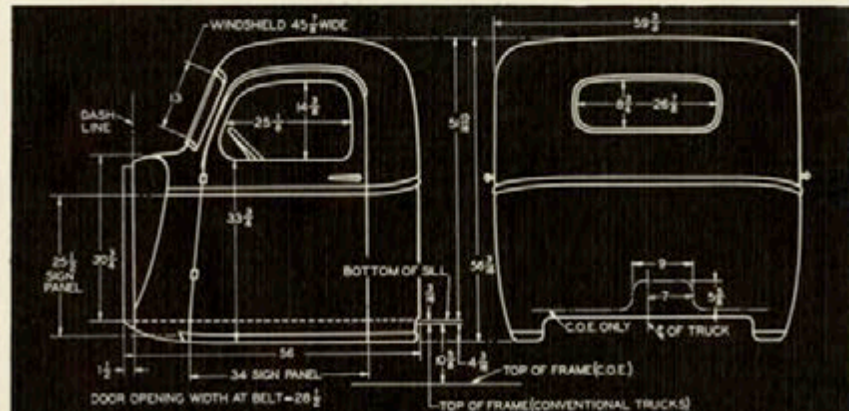
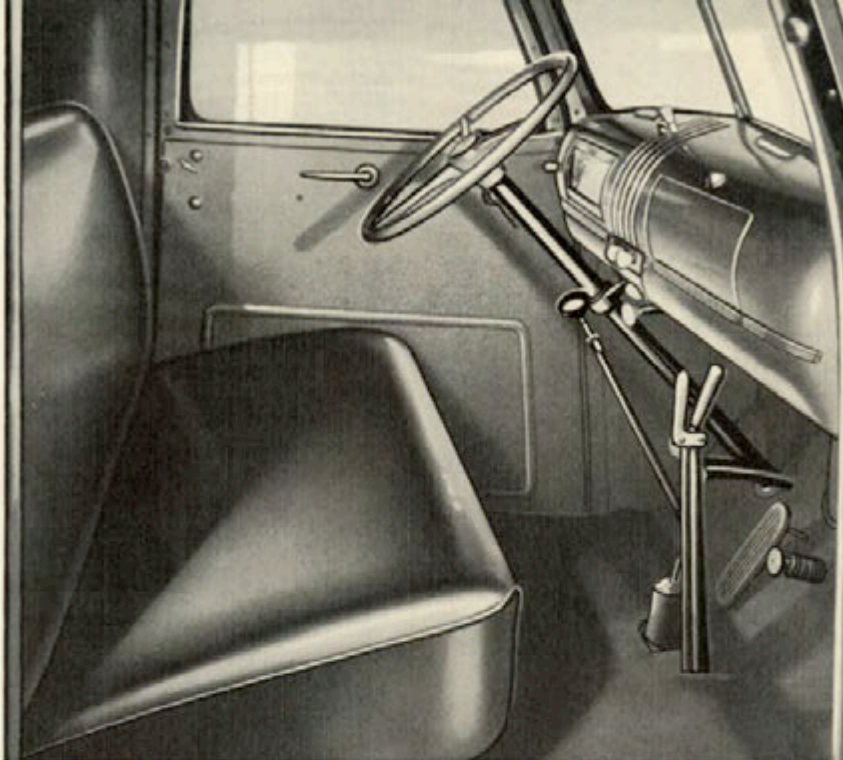
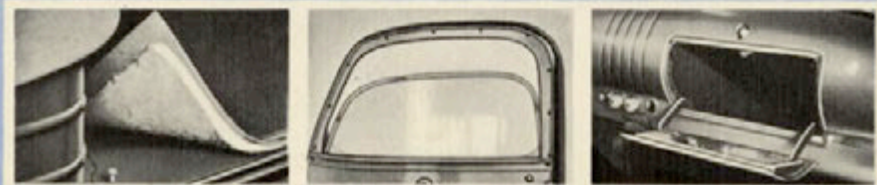
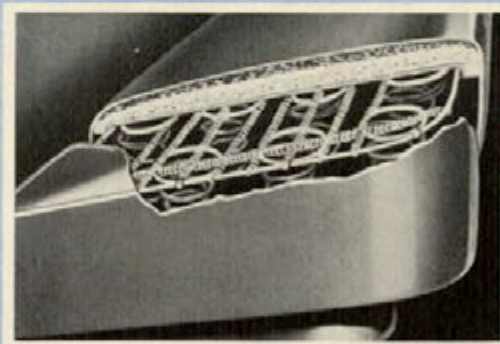

Features

OF THE CHEVROLET

Cab-Over-Engine Truck

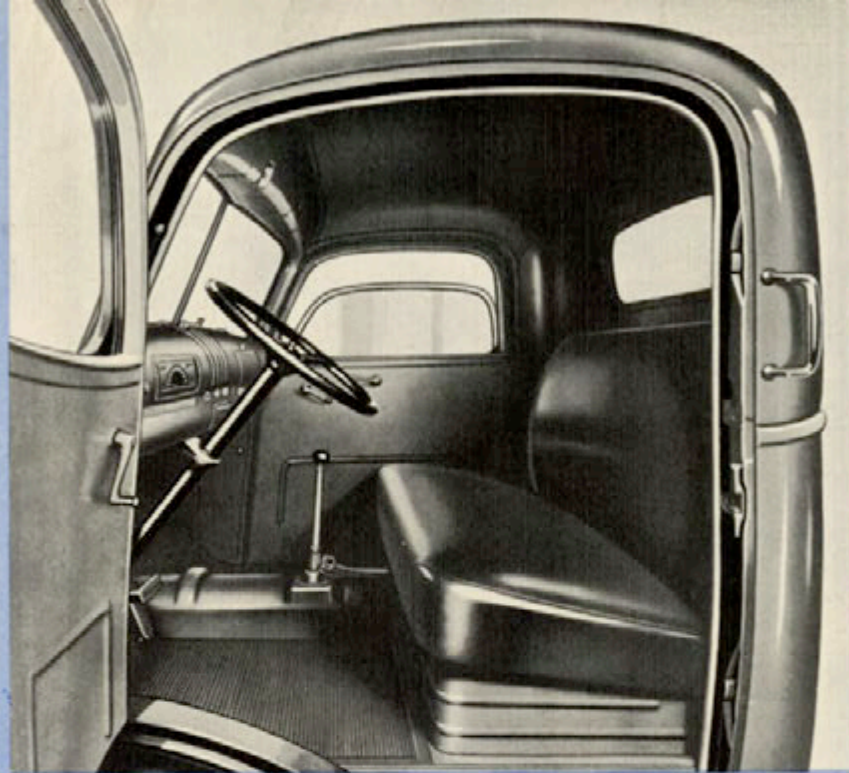

Cab—The over-engine cab possesses the special features of the standard Chevrolet cab (page 30), plus many distinctive features that make it the most practical over-engine cab ever built. The single seat cushion, 50 inches wide, extends from door to door; three men can ride without crowding. Two side ventilators have air scoops which provide for extra ventilation. Two steps and wide doors make easy entrance to the cab.

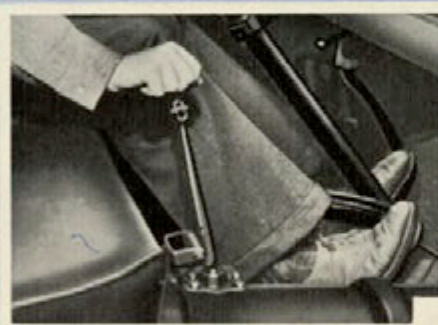

Normal Gearshift—(left) The gearshift lever is in the regular location to which all drivers are accustomed, rather than at the rear of the cab between seat cushions (as in some C. O. E. trucks).

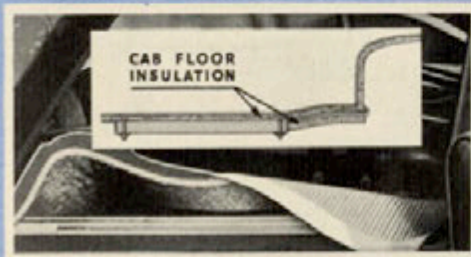

Insulation—Heavy insulating panels are built into the floor and cover; in addition, the floor mat has a heavy insulating pad.



Engine Accessibility—(left) The hood is redesigned for 1941. The top is hinged at the rear and the upper half of the grille is part of the hood, which can be easily opened for access to the engine.

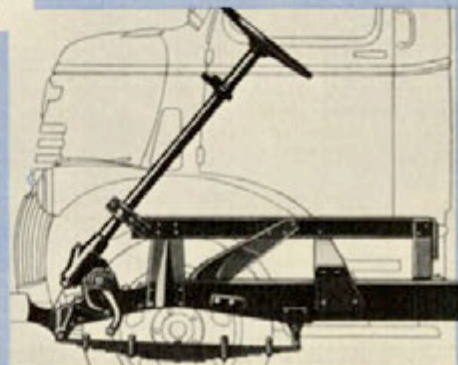

Sturdy Sub-Frame—(right) The cab is mounted on a heavy sub-frame, 10 $\frac{3}{8}$ inches higher than the chassis side-rails. This sub-frame gives full-length support to the cab.

Body Features

OF THE UNIT-DESIGNED CHEVROLET

Panel Trucks

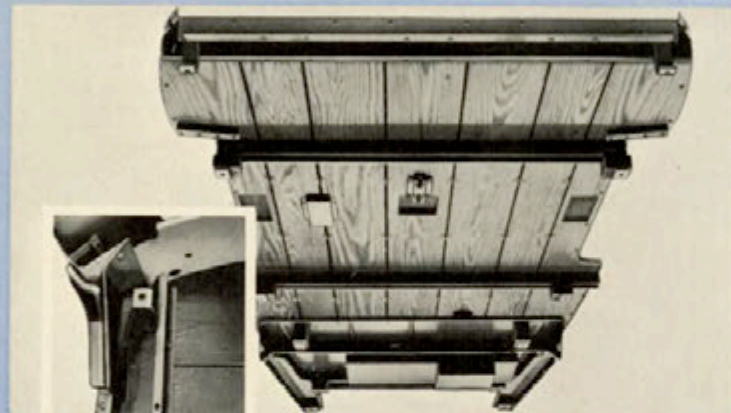

Floor—Planks are of selected lumber, laid with expansion joints to prevent buckling. Steel skid strips make each joint dustproof and waterproof. A six-way brace (left) securely ties the side panel assemblies to the floor.



Floor and Panel Assembly—Rear door pillars are set on a 45-degree angle, so that the doors when fully opened do not obstruct the loading space.



Complete Body Assembly—Doors are made of inner and outer deep-drawn stampings securely clinched and welded together. Note unobstructed door opening.

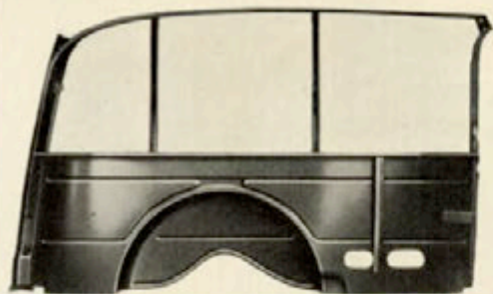

Lining for Side Panel—The inside lining panel is of heavy gauge steel; the wheel house is pressed into the panel, not welded.

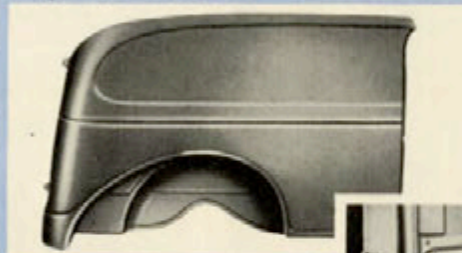

Driver's Seat—Form-fitting; deeply upholstered over hour-glass springs.

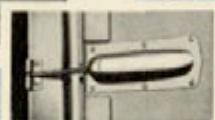

Door Stops—Fully enclosed and automatic, permit full door opening.

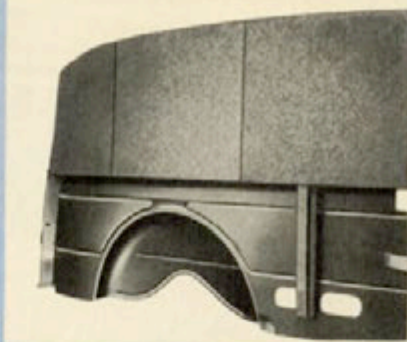

Insulation—Masonite pressed board insulating panels are unaffected by moisture.

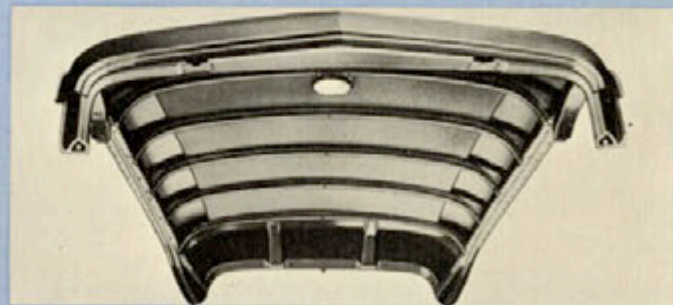
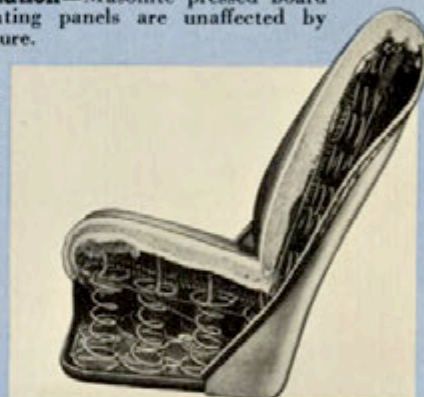

Roof—The one-piece steel top is reinforced with deep arched cross-bows welded to the deep roof joiner rail. It is the strongest top construction in any panel truck. Insulation is an asphalted felt pad.

Body Features OF THE CHEVROLET Canopy Express

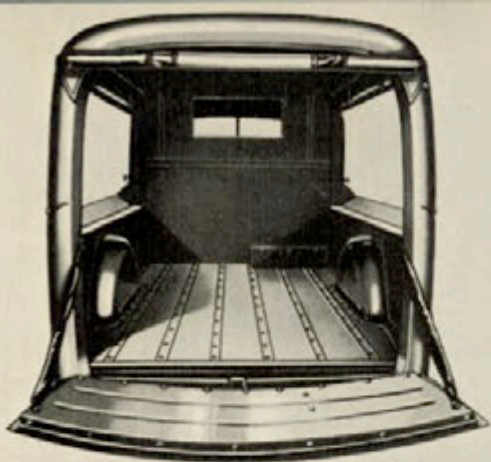

Complete Body Assembly—The loading compartment is finished without interior angles and braces, so that loading and unloading are facilitated and load space is at the maximum.

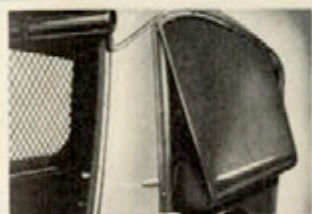

Curtains—Made of rubberized duck, tailored to conform to the body styling, and held with quick-action fasteners. A rod within the bottom edge facilitates rolling up. Screen sides protect merchandise from theft (available at extra cost).

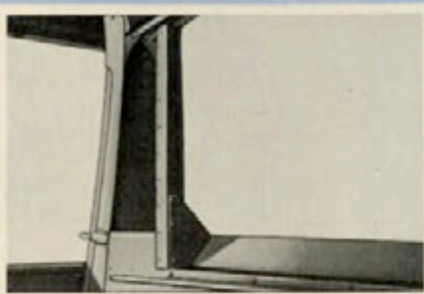

Rear Pillars—Heavy steel structural rails reinforce the box-type rear door pillars, forming an extraordinarily strong support.



Roof—The one-piece steel top is reinforced with deep arched cross-bows welded to the deep roof joiner rail. It is the strongest top construction offered in any panel truck.

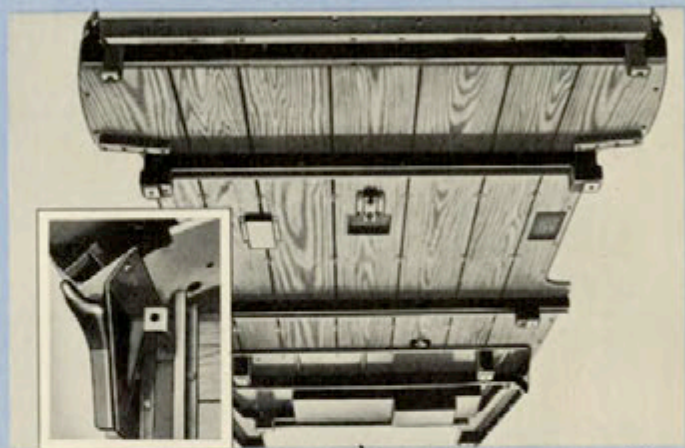

Floor—Planks are of selected lumber, laid with expansion joints. Steel skid strips make each joint dustproof and waterproof. A six-way brace (left) securely ties the side panel assemblies to the floor.

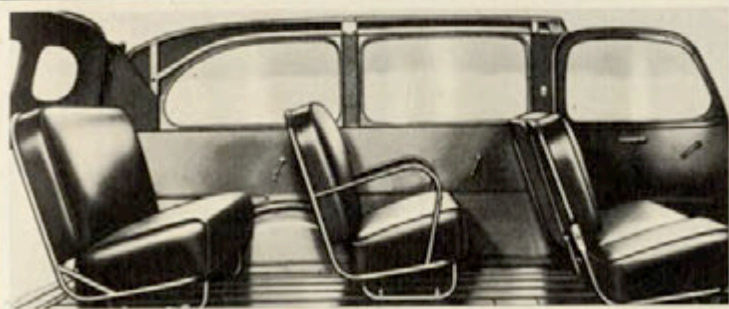

Seating Arrangement—Eight persons may ride comfortably on deeply padded seat cushions and backs mounted in tubular seat frames. All hardware is of chrome finish. Above the belt line imitation leather trim is used.



Tail-Gate—A full box-type construction, the drop tail-gate is adapted to carrying a full load of luggage.

Body Features OF THE CHEVROLET Carryall Suburban

Lift-Gate—The upper half of the rear closure is mounted on heavy hinges and provided with sturdy supports to hold it in the opened position. Regular panel type (vertical) doors are optional.

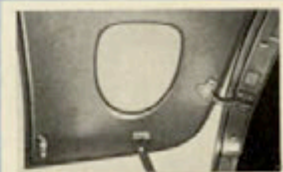

Body Features OF THE CHEVROLET Pick-up Trucks



Heavy side braces are welded to the side panels.

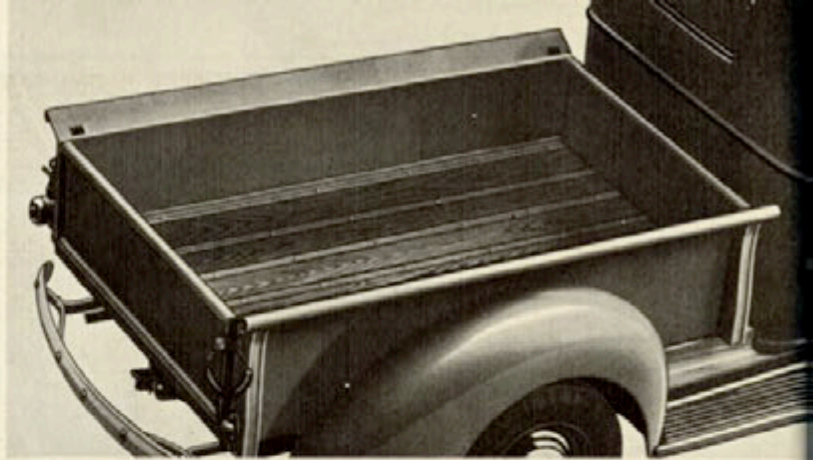

Construction—Pick-up bodies (*Light Delivery* above, *Heavy Duty* below) are of heavy-gauge steel, with durable wooden floor reinforced and protected with steel skid strips. The side panels and flare-boards are pressed out of one piece of steel. Special reinforcing sections are formed into the edges of the flare-boards.

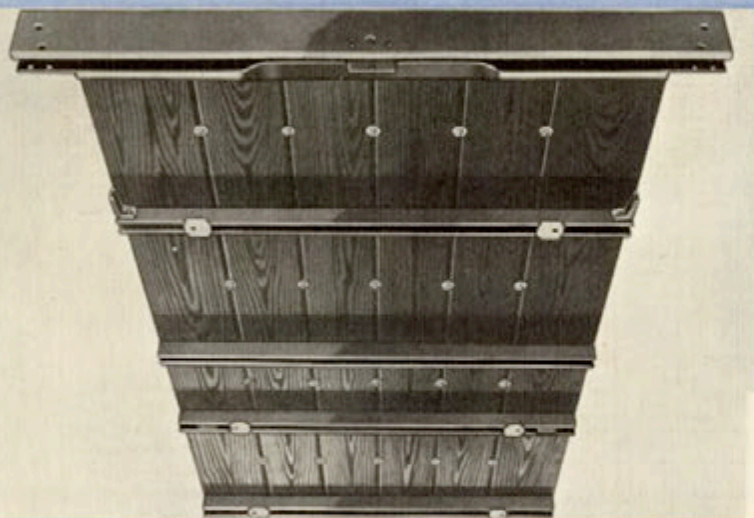

Platform—The floor of the Light Delivery Pick-up body, illustrated above, is typical of the special construction used in all models. Five heavy box-type deep-drawn steel cross-members form the frame on which the floor is built. The rear sill is extended to form, with the rear side panel brace, a cantilever construction that maintains absolute alignment.

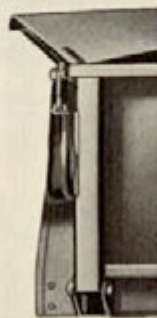

Three heavy channel-type hinges support the tail-gate.

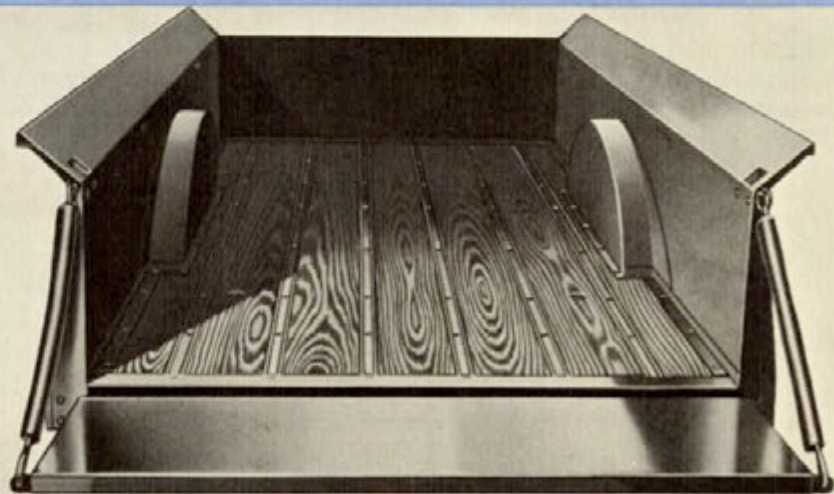

The tail-gate, heavily reinforced with box-type girders and channels, is welded to form an all-steel unit of extraordinary strength and rigidity.

Body Features OF THE CHEVROLET Stake Trucks

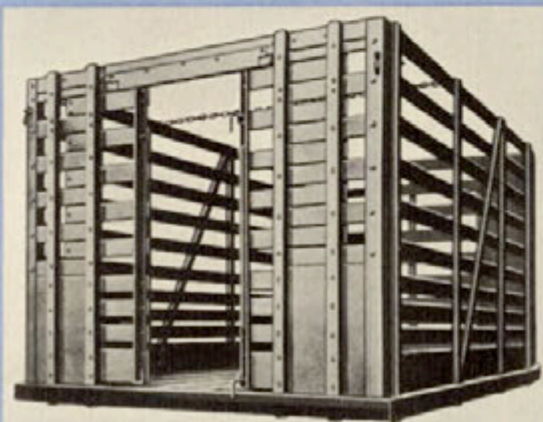
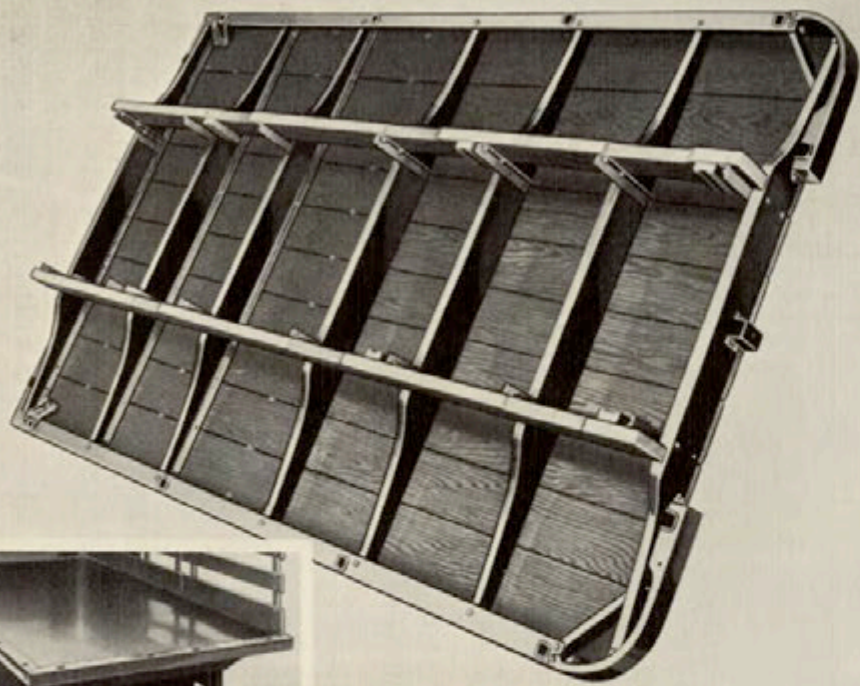

Body Platform—The floor is a platform of selected lumber, supported on cross-sills of heavy channel steel, securely attached and braced to form a rigid unit of great strength. A steel floor is available at extra cost.

High Rack—Safety end-gates open by sliding to the left and right, for greater safety in loading livestock. They may be locked securely at the center. The inside of the rack and floor is free from obstructions or projections that might cause injuries.

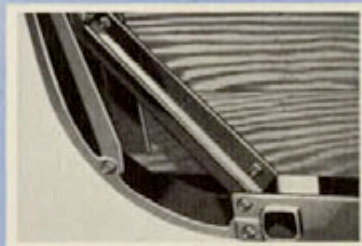

Corner Bracing—The heavy channel steel brace is attached under the platform to reinforce the rounded front corners.

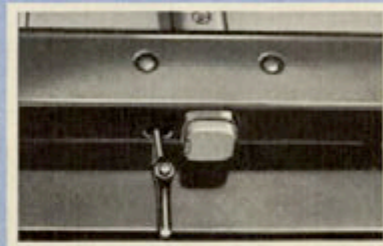

Stake Lock—The rear stakes are securely locked in their pockets by a positive, hook-type fastener below the rear rub-rail.

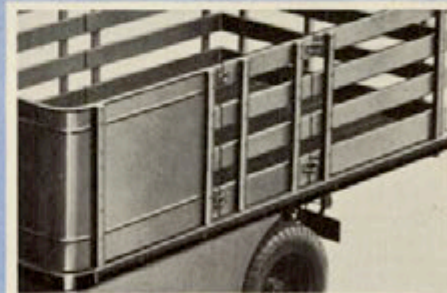

Stake Construction
Stakes are made of hardwood, slats of long-leaf Southern pine. The slats are held to the stakes with bolts that are flush both inside and outside. Front corners are rounded for added strength and to prevent damage to the corners of the body.

Stake Joiners—This interlocking hook between stake sections is assurance against lost stake sections. These joiners are positive, yet easy to fasten and unfasten.

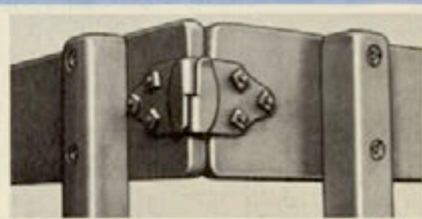

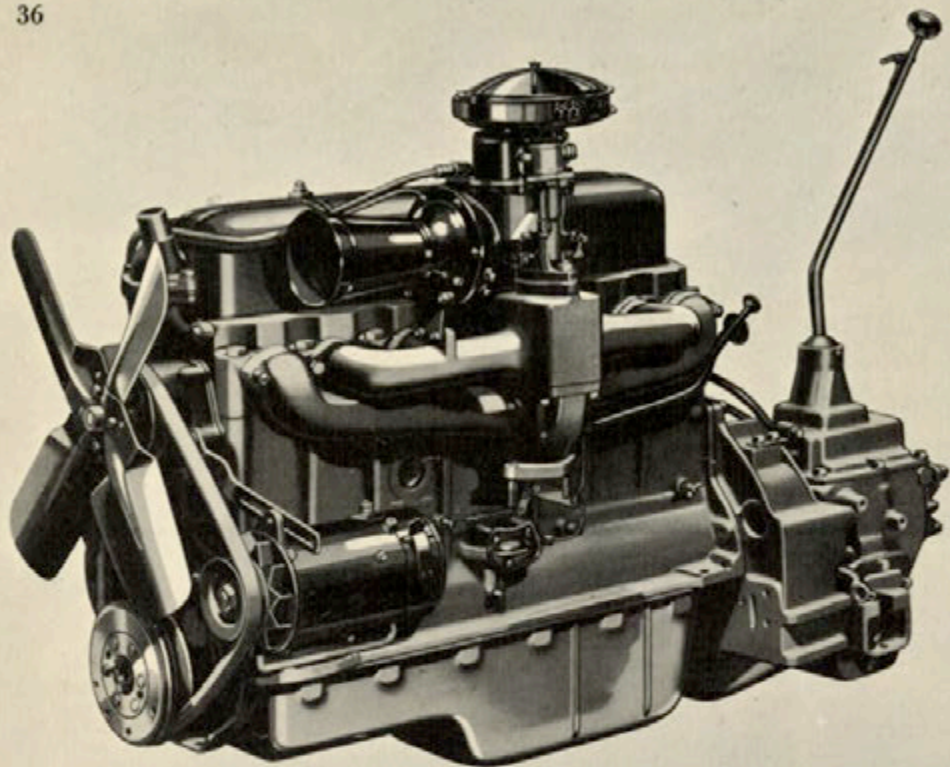

Four-Bearing Crankshaft—The shaft, weighing 68 pounds, is forged with integral counterweights. Four main bearings with large area provide rigid support. Harmonic balancer gives smoother operation, resulting in longer life for the bearings.

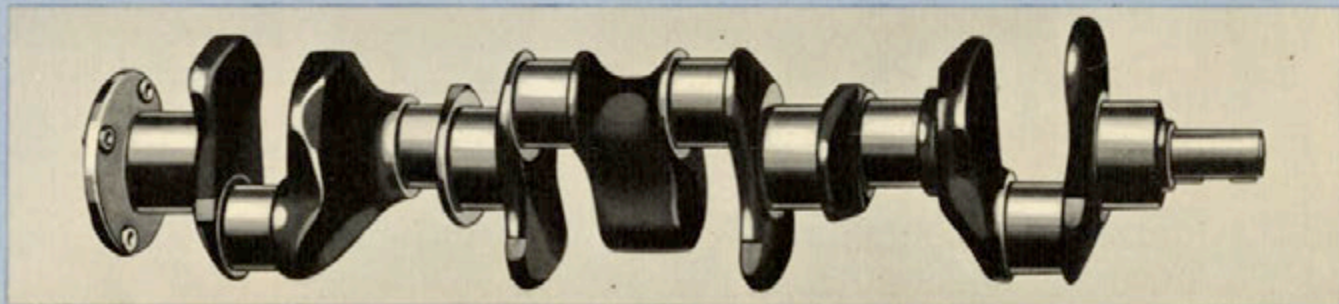

1941 ENGINE

Chevrolet's famous Valve-in-Head Six, noted for its performance and its economy, has been increased in horsepower for 1941 and now develops 90 horsepower, twelve more than before. This increased power has been gained without increasing the displacement, by redesigning the combustion chamber shape, with slight increase in compression ratio. Fuel economy is better throughout the speed range. In addition, numerous improvements have been made in the ignition, fuel, cooling and oiling systems, contributing further to the efficiency, smoothness and durability of the engine.

Valve-in-Head Principle—Diagrams below illustrate four of the factors that make valve-in-head engines superior to other types. These are (left to right) faster intake of fuel mixture, better location of valves, quicker flow of exhaust gas, and less area to absorb heat during the power stroke.

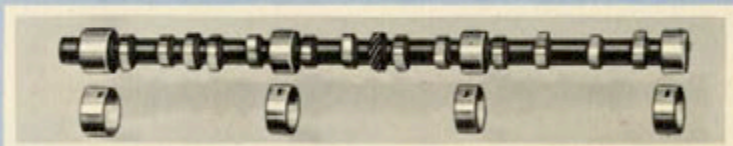

Camshaft—The four-bearing camshaft of drop-forged steel runs on four steel-backed babbitt bearings.

FEATURES

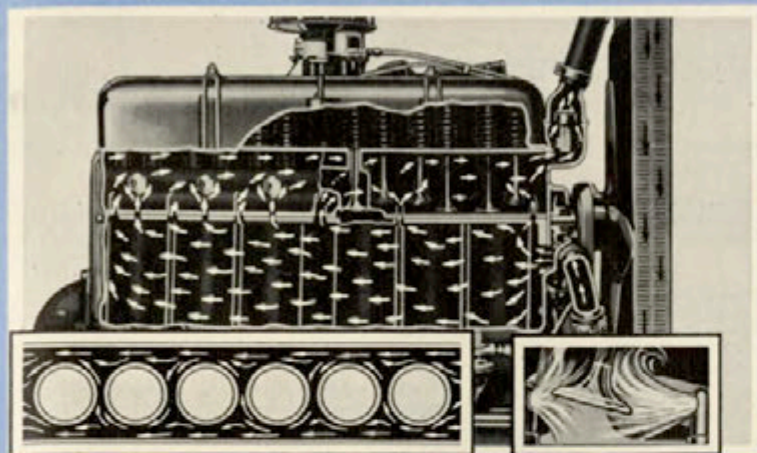

Cooling System—It includes full-length water jackets, nozzle-spray valve-seat cooling, leakproof water pump, and thermostatic heat control. Individual cooling of cylinders results in controlled expansion.

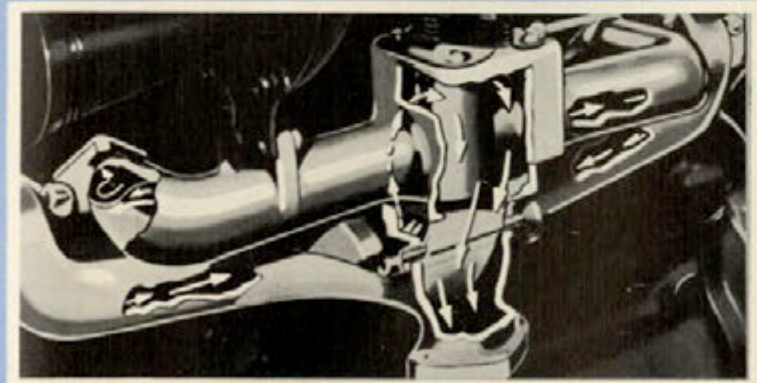

Thermostatic Heat Control—The heat chamber in the manifold, with thermostatic control, assures prompt warm-up and maintains correct operating temperatures.

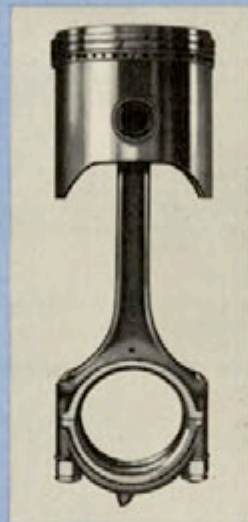

Four-Way Specialized Lubrication

Oil is fed to the moving parts in direct proportion to their individual needs. Exclusive to Chevrolet is the pressure jet oiling of the connecting rod bearings. Oil under extremely high pressure is forced through the bearing at each revolution.

Truck Pistons

Special, heavy walled pistons of lightweight cast alloy iron are designed to stand up under the severest use and to maintain a close fit for many extra thousands of miles.

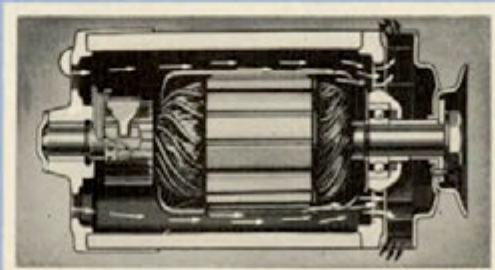

Generator—The heavy duty high-capacity generator (ventilated) is equipped with voltage and current regulators.

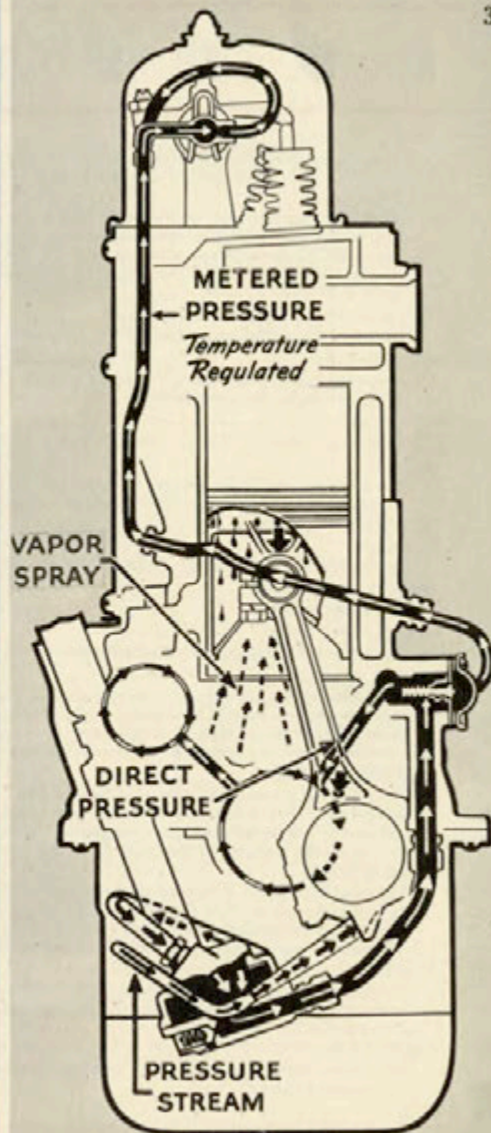

1 9 4 1 C H E V R O L E T T R

(For details of the different chassis models, see under corresponding columns on opposite page.)

ENGINE:

Six-cylinder valve-in-head, 3½" bore, 3¼" stroke; piston displacement, 216.5 cubic inches. S. A. E. rated horsepower, 29.4. Maximum horsepower, 90. Maximum torque, 174 pound-feet. Compression ratio, 6.5:1. (Engine of School Bus chassis equipped with governor set for maximum speed of 35 miles per hour.)

CRANKCASE and CYLINDER BLOCK:

Cylinders cast en bloc with upper half of crankcase.

CRANKSHAFT:

Drop-forged steel, heat treated. Weight, 68 pounds. Four main bearings. Counterbalanced. Harmonic balancer.

CAMSHAFT:

Drop-forged steel, heat treated. Four bearings.

PISTONS:

Special heavy duty truck pistons of lightweight cast alloy iron, with slipper skirt. Electroplated. Three rings above pin. Diamond-bored bushings in pin bosses.

VALVES:

Intake, 1¼" outside diameter. Exhaust, 1½" outside diameter.

ENGINE SUSPENSION:

Rubber mountings.

CONNECTING RODS:

Drop-forged steel, heat-treated. Diamond-bored high lead babbitt bearings.

OILING SYSTEM:

Specialized system, with pressure streams of oil to connecting rod bearings (instant cold starting lubrication) and positive pressure to crankshaft and valve rocker-arms. Gear-type pump in crankcase, with screen on intake. Crankcase ventilator. Refill capacity, 5 quarts.

COOLING SYSTEM:

Self-adjusting, permanently lubricated ball bearing water pump, centrifugal type. Harrison ribbed cellular all-copper radiator core. Individually cooled cylinders, full-length water jackets. Nozzle-spray valve seat cooling. Water capacity, 14 quarts (on C. O. E., 16 quarts).

CARBURETION:

Improved 1¼" Carter downdraft carburetor (specially designed Carter updraft carburetor on C. O. E.). Fuel mixture heated (thermostatic control) in manifold heat chamber. High reserve fuel pump. AC air cleaner and flame arrester (improved oil bath air cleaner on C. O. E.).

IGNITION:

Delco-Remy, with automatic vacuum spark advance. High-intensity spark with polarity-reversing switch for breaker points. Moisture and waterproof coil. Octane selector.

GENERATOR:

Delco-Remy high-output, heavy-duty ventilated generator with voltage and current regulator.

GENERATOR:

Delco-Remy; positive shift mechanical engagement.

BATTERY:

Delco, 15-plate 100-ampere-hour capacity. Fitted with non-overflow caps.

CLUTCH:

Diaphragm spring type, with single drive plate. Ventilated. Cushion-mounted disc with radial slotted, braided, molded facings riveted on clock-spring-steel cushions. Permanently lubricated throwout bearing.

TRANSMISSION:

On *Sedan Delivery* and *Coupe Pick-up*, three-speed Synco-Mesh, with helical gears throughout; vacuum-power gearshift. On *Light Delivery* and ¾-Ton models, three-speed Synco-Mesh with helical carburized gears throughout; manual shift (four-speed transmission available at extra cost). On all other models, four-speed sliding-gear transmission, with provision for power take-off.

UNIVERSAL JOINTS:

Needle-bearing type, except for the front universal of ¾-Ton models which is bushing type.

STEERING GEAR:

On *Sedan Delivery* and *Coupe Pick-up*, worm and ball bearing roller sector; worm-mounted on tapered roller bearings. Shockproof steering. Ratio, 17½:1. On all other models, roller-bearing-mounted worm and straddle mounted sector; worm transmits motion to steering sector through ball bearings in a continuous spiral race.

FRONT AXLE:

On *Sedan Delivery* and *Coupe Pick-up*, Knee-Action with fully-sealed bearings and high-efficiency, built-in, double-acting shock absorbers; ride stabilizer. On all other models, heavy drop-forged, heat-treated I-beams.

REAR AXLES:

Hypoid drive gears. On all Heavy Duty models, full-floating type; on all others, semi-floating.

BRAKES:

Hydraulic service brakes front and rear, with self-aligning full contact shoes. Mechanical emergency brakes cut in on rear wheels.

WHEELS:

Short-spoke or pierced steel disc.

LOAD CAPACITY CHART—GROSS ALLOWABLE WEIGHTS FOR 1941 CHEVROLET TRUCKS

MODEL	NOMINAL RATING	GROSS WEIGHT	MINIMUM TIRE EQUIPMENT		REQUIRED EQUIPMENT		
			Front	Rear	Rear Springs	Governed Speed	Rear Axle
LIGHT DELIVERY	Half ton	4400	6.00-16-4 ply	6.00-16-4 ply, single	8 leaf	—	4.11
DUBL-DUTI PANEL		*4600	6.00-16-6 ply	6.00-16-6 ply, single	8 leaf	—	
¾-TON	¾ ton	5200	15'-6 ply	15'-6 ply, single	7 leaf	—	4.55
¾-TON SPECIAL		*5800	7.00-17-6 ply	7.00-17-6 ply, single	Light 8 leaf	—	
ONE-TON	One ton	6700	6.00-20-6 ply	6.00-20-6 ply, single	—	—	5.43
HEAVY DUTY CONVENTIONAL AND CAB-OVER-ENGINE		7700	6.00-20-6 ply	7.00-20-8 ply, single	—	—	
HEAVY DUTY CONVENTIONAL AND CAB-OVER-ENGINE	1½ ton	8000	6.00-20-6 ply	7.50-20-8 ply, single	Heavy 10 leaf	—	6.17
		9500	6.00-20-6 ply	6.00-20-6 ply, dual	—	—	
		*11500	6.50-20-6 ply	7.50-20-8 ply, dual	Heavy 10 leaf and auxiliary	—	
SCHOOL BUS	1½ ton	13500	7.50-20-8 ply	7.50-20-8 ply, dual	Heavy 11 leaf	35 m.p.h.	Two Speed 5.64 and 8.22
		9500	6.50-20-6 ply	7.00-20-8 ply, dual	—	—	
HEAVY DUTY CONVENTIONAL AND CAB-OVER-ENGINE 2-SPEED REAR AXLE	1½ ton	11500	7.00-20-8 ply	7.50-20-8 ply, dual	—	—	45 m.p.h.
		13500	7.00-20-8 ply	7.50-20-8 ply, dual	Heavy 10 leaf and auxiliary	—	
		*12000	7.00-20-8 ply	8.25-20-10 ply, dual	—	—	
		*14000	7.00-20-8 ply	8.25-20-10 ply, dual	—	—	45 m.p.h.

*A plate is supplied with each vehicle which shows maximum gross rating. This gross is reduced per above table when lighter equipment is used.

U C K S P E C I F I C A T I O N S

	Sedan Delivery	Light Delivery	3/4-Ton	3/4-Ton Long Wheelbase Panel	Heavy Duty Conventional	Heavy Duty Cab-Over-Engine			Short School Bus	Long School Bus			
Wheelbase	116"	115"	125 1/4"	134 1/2"	134 1/2"	160"	109 1/4"	132 1/4"	158 1/4"	160"	195 1/4"		
Back of cab to center line of rear axle		38 1/4"	48 1/2"		57 3/4"	83 1/4"	62 1/2"	80"	111 1/2"				
Center line of rear axle to end of frame	36 1/2"		36 1/2"	46 1/2"	34 1/2" (46 1/2" on 134 1/2" W.B. Panel and Canopy Express)						85"		
Back of cab to end of frame		74 1/4"	85"		92 1/4"	118 1/4"	97 1/4"	120 1/4"	146 1/4"				
Approximate chassis shipping weight in pounds	Single wheels		2380	3725 with body	3035	3280	3345	3440	3725				
	Dual wheels				3175	3420	3485	3580	3865	3560	3770		
	Cab, single wheels		2635	2780	3430	3685	3555	3640	3940				
	Cab, dual wheels				3570	3825	3695	3780	4080				
Clutch disc diameter	9 1/2"				10 1/4"								
Drive system	Torque tube drive				Hotchkiss type								
Propeller shafts	1			2		1		2		3			
Frame	Side Rail Section	Flanged box	Channel										
		4 1/2" deep	5 1/4" deep	5 1/2" deep	7" deep						7 1/4" deep		
		2 1/4" wide	2 1/4" flanges	2 1/4" flanges	2 1/4" flanges						2 1/2" flanges		
	1/2" wall	1/2" thick	1/2" thick	1/2" thick						1/4" thick			
Cross-members	3	5			6	5		6	7	8			
Front spring	Coil, with ride stabilizer	Ride Stabilizer	Semi-elliptic										
		36" long, 1 1/4" wide	40" long, 2" wide										
		7 leaves	8 leaves	7 leaves			8 leaves		9 leaves				
Rear spring	49" long	54 1/2" long	46" long, 2" wide		46" long, 2 1/2" wide, 10 leaves. Special 8-leaf spring is standard on 134 1/2" W.B. Panel and 1-Ton Chassis			46" long		46" long			
	1 1/4" wide	1 1/4" wide	Two-stage					2 1/2" wide		2 1/2" wide			
		8 leaves	7 leaves	8 leaves				10 leaves		11 leaves, two-stage			
Front axle	Wheel bearings	Ball type								Barrel roller type		Ball type	
	Thrust bearings									Roller type			
Rear axle, ratio	4.11 to 1			4.55 to 1			6.17 to 1, 5.43 to 1						
Brakes	Drum diameter	11" front and rear		11" front, 14" rear			14" front, 16" rear						
	Lining width	1 1/4" front and rear		1 1/4" front, 2" rear			2" front, 3" rear						
Wheels	Integral drop-center rim					Lock ring rim							
Fuel tank	16 gallons	16 gallons				18 gallons			20 gallons	18 gallons			
		18 gallons in cab	(20-gallon side-mounted tank optional on long school bus chassis)										

3/4-Ton Chassis with Heavy Duty equipment also available. **One-Ton Chassis also available. 1Side member reinforcement plates are standard equipment on 160" W.B. Heavy Duty Conventional, 158 1/4" W.B. Heavy Duty Cab-Over-Engine, 160" and 195 1/4" W.B. School Buses. 1Ride Stabilizer on Light Delivery Chassis, Panel Truck and Carryall Suburban. The right is reserved to change specifications, colors or prices without incurring any responsibility with regard to trucks or chassis previously sold. Chevrolet trucks can be purchased on the General Motors Installment Plan—convenient, economical monthly payments. Accessories on all trucks, and spare tires on One-Ton, Heavy Duty Conventional, Heavy Duty C.O.E. and School Bus models, are at extra cost.



**MOTOR, SHEET METAL
AND ASSEMBLY PLANTS
FLINT, MICHIGAN**



**MOTOR AND AXLE PLANT
TONAWANDA, N. Y.**

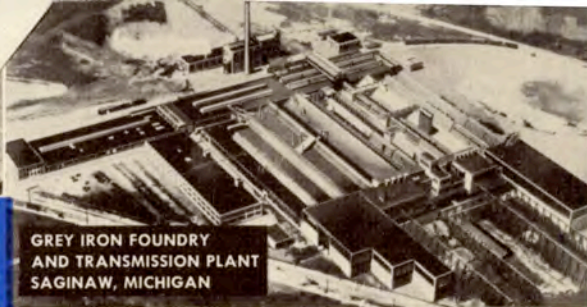

**GREY IRON FOUNDRY
AND TRANSMISSION PLANT
SAGINAW, MICHIGAN**



**ASSEMBLY PLANT
BUFFALO, N. Y.**

Chevrolet's highly developed system of production is assurance of the utmost quality and value. Chevrolet makes its engines and mechanical units in highly specialized manufacturing plants, and builds its own truck bodies in the largest single plant of its type in the world. Then, in assembly plants situated throughout the country, the Chevrolet-made chassis units and bodies are assembled, tested, and made ready for the road, before being shipped for sale through Chevrolet's dealer organization.



**ASSEMBLY PLANT
TARRYTOWN, N. Y.**



**COMMERCIAL BODY PLANT
INDIANAPOLIS, INDIANA**

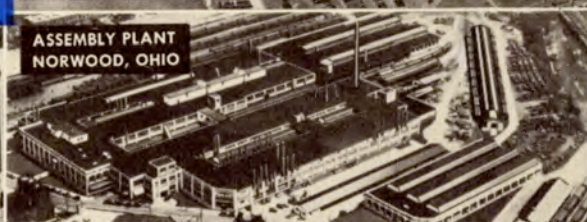

**ASSEMBLY PLANT
NORWOOD, OHIO**



**ASSEMBLY PLANT
OAKLAND, CALIFORNIA**



**FORGE AND
GEAR AND AXLE
PLANTS
DETROIT, MICHIGAN**



**ASSEMBLY PLANT
BALTIMORE, MARYLAND**



**SMALL PARTS MANUFACTURING
BAY CITY, MICHIGAN**



**ASSEMBLY PLANT
ST. LOUIS, MISSOURI**