

# TRANSMISSION

	Page
CUTAWAY VIEW .....	3-2
4-SPEED TRANSMISSION (H41 & H42) ...	3-3
3-SPEED TRANSMISSION (J30) .....	3-42

### CUTAWAY VIEW

Fig. 3-1

4-Speed Manual Transmission (H41 & H42) & Transfer

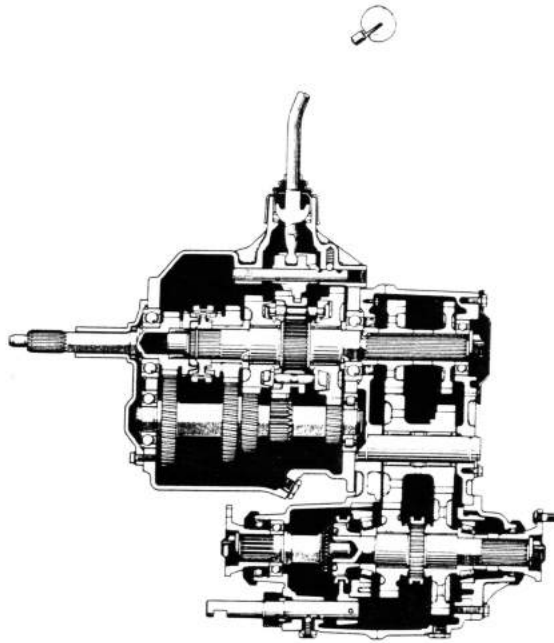

3-Speed Manual Transmission (J30) & Transfer

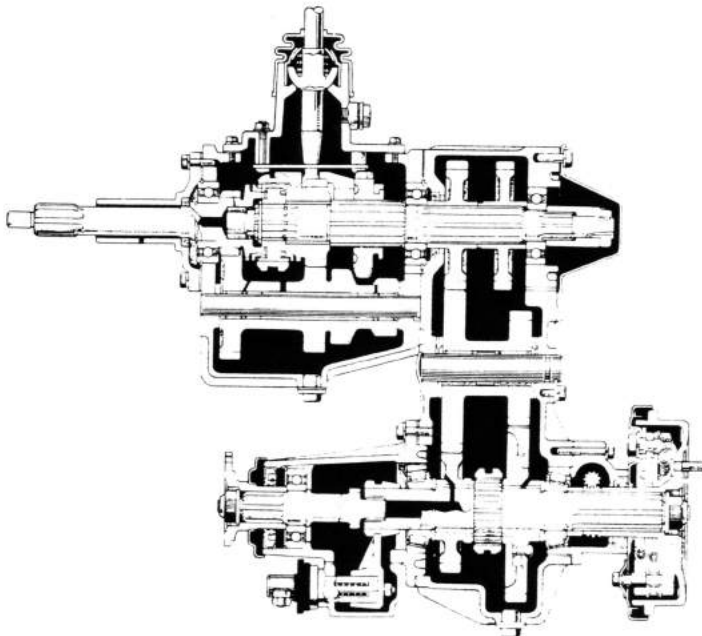

## 4-SPEED TRANSMISSION (H41 & H42)

### REMOVAL

#### Remove From Vehicle

1. Drain the transmission and transfer oil.
2. Remove the parts in the numerical order shown in the figure.

Fig. 3-2

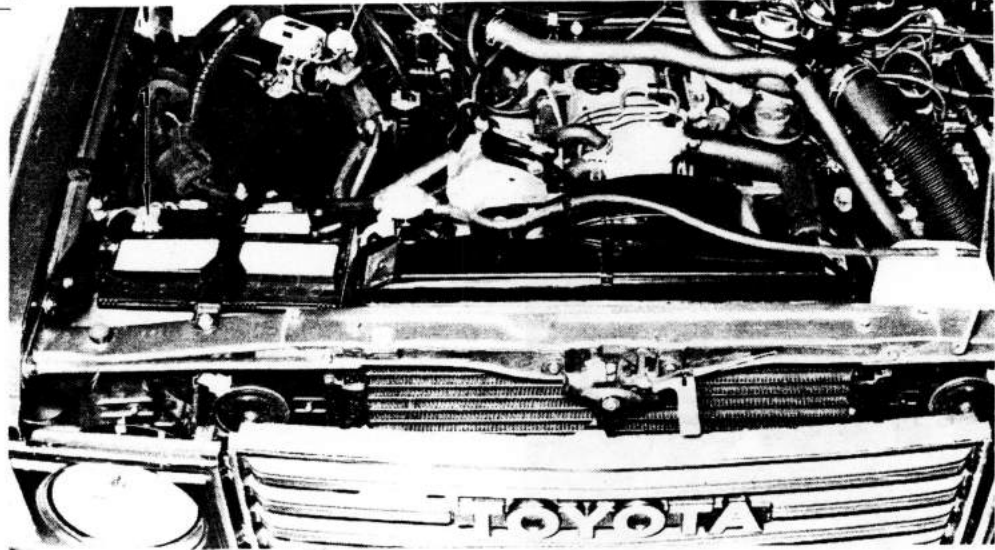

1. Battery Terminal
2. Scuff Plate
3. Cowl Side Trim

4. Heater Duct
5. Carpet or Mat

Fig. 3-3

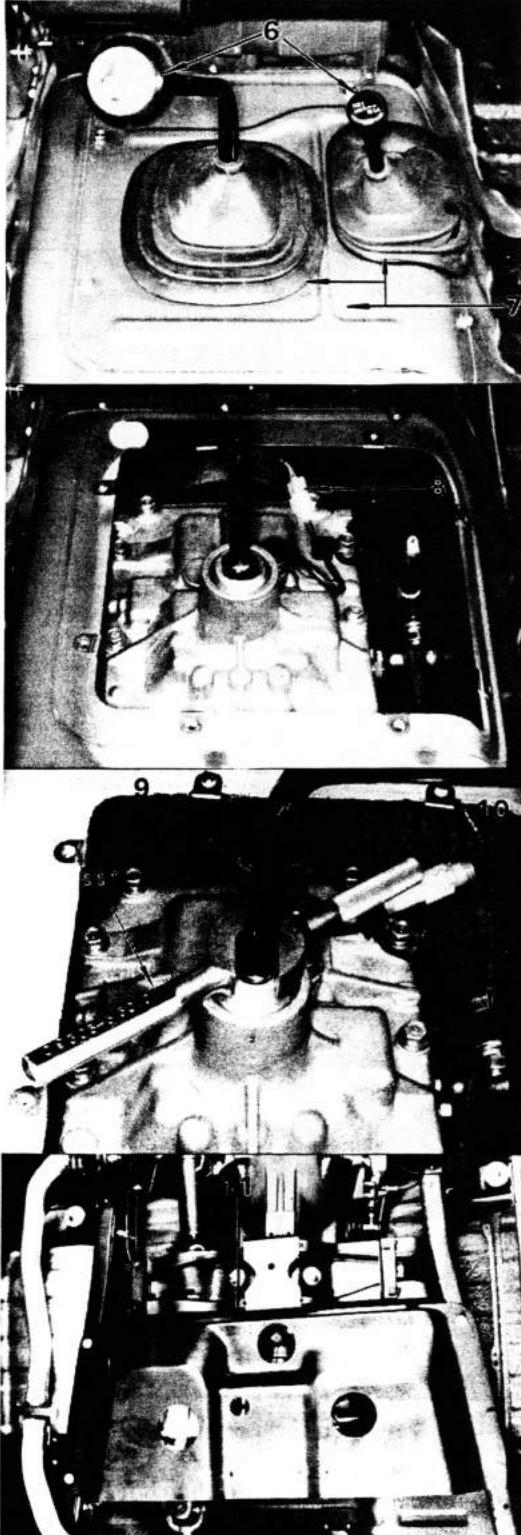

- 6. Shift Lever Knob & Transfer Knob
- 7. Service Hole Cover with boot

- 8. Back-up Light Switch Connector

- 9. Shift Lever  
SST [09305-55010]
- 10. Transfer Shift Lever

- 11. Under Guard

Fig. 3-4

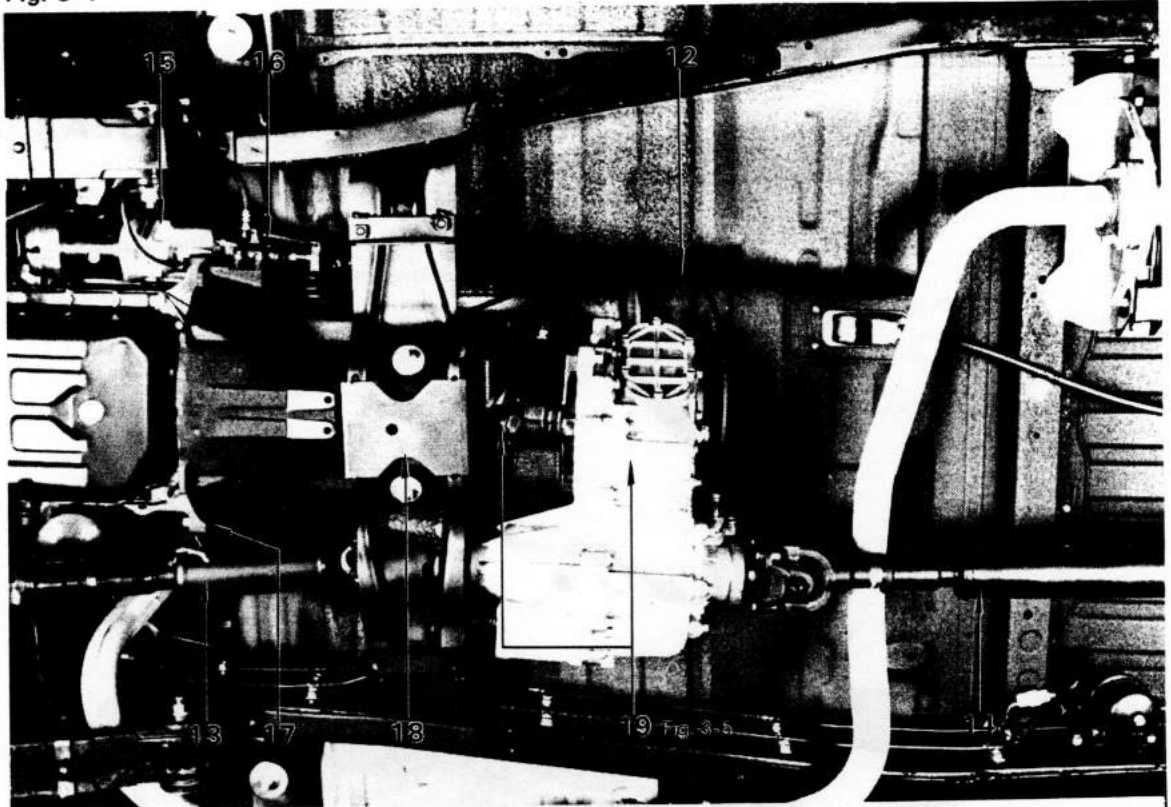

- |                                   |   |
|-----------------------------------|---|
| 12. Speedometer Cable             | 16. Clutch Release Cylinder (For BJ Series) |
| 13. Front Propeller Shaft         | 17. Tachometer Sensor (For BJ, HJ Series)   |
| 14. Rear Propeller Shaft          | 18. Engine Rear Supportmember               |
| 15. Starter Motor (For BJ Series) | 19. Transmission & Transfer                 |

Fig. 3-5

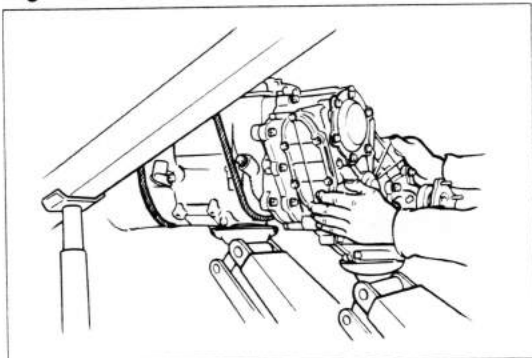

Support the transmission and transfer assembly with jacks and a rope, and remove.

## TRANSMISSION GEAR & CASE

### REMOVAL

1. Remove the parts in the numerical order shown in the figure.

Fig. 3-6

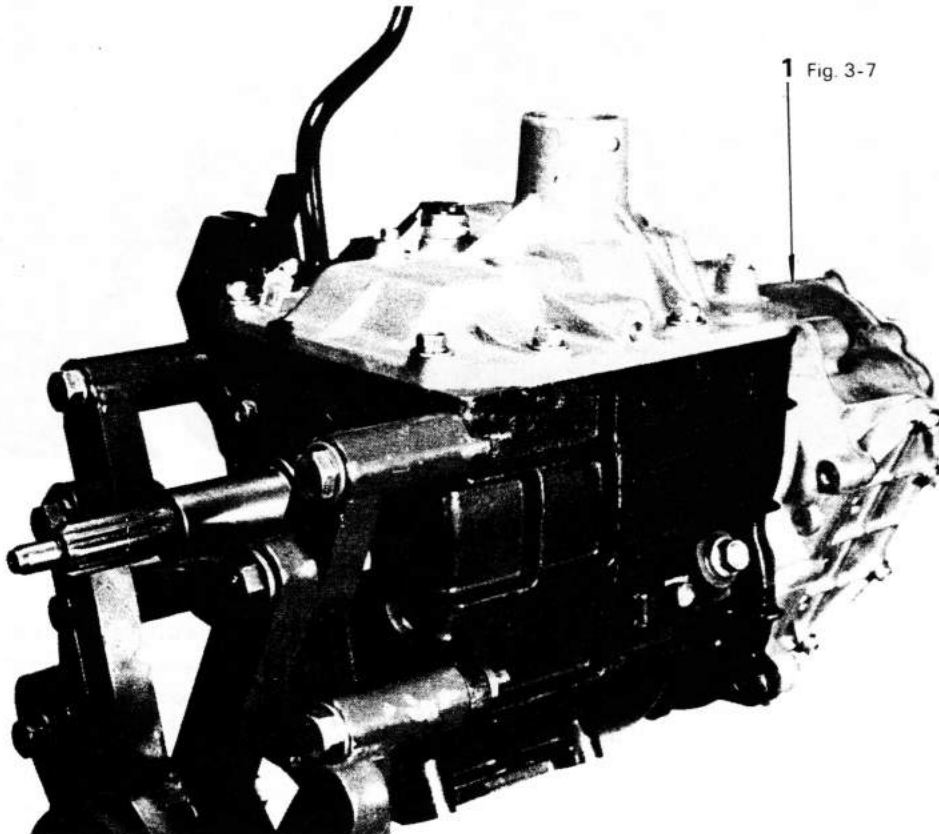

1. Transfer

Fig. 3-7

SEE  
TRANSFER DISASSEMBLY  
SECTION  
Fig. 4-1 to 4-24

Separate the transfer from the transmission.

2. Disassemble the parts in the numerical order shown in the figure.

Fig. 3-8

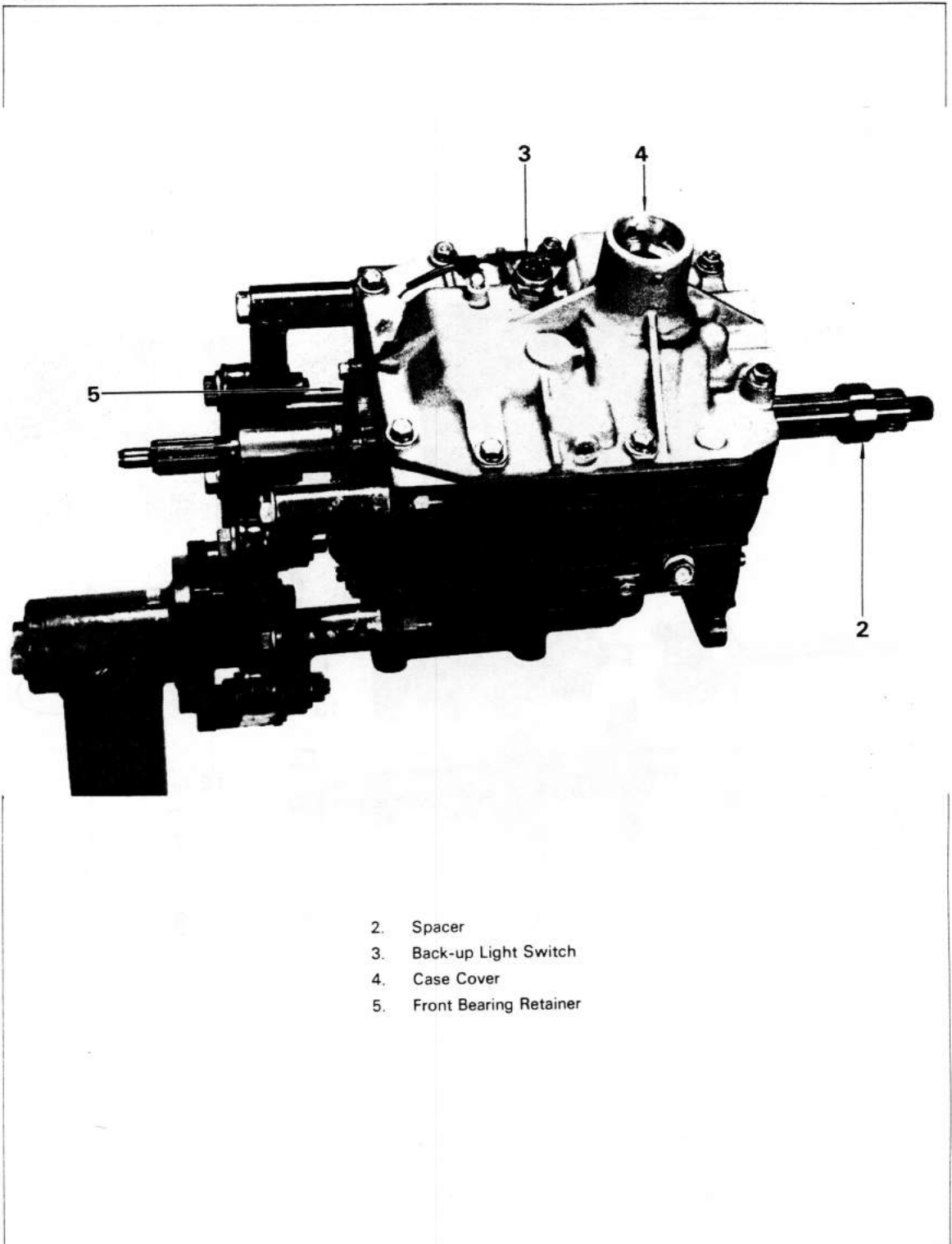

3. Disassemble the parts in the numerical order shown in the figure.

Fig. 3-9

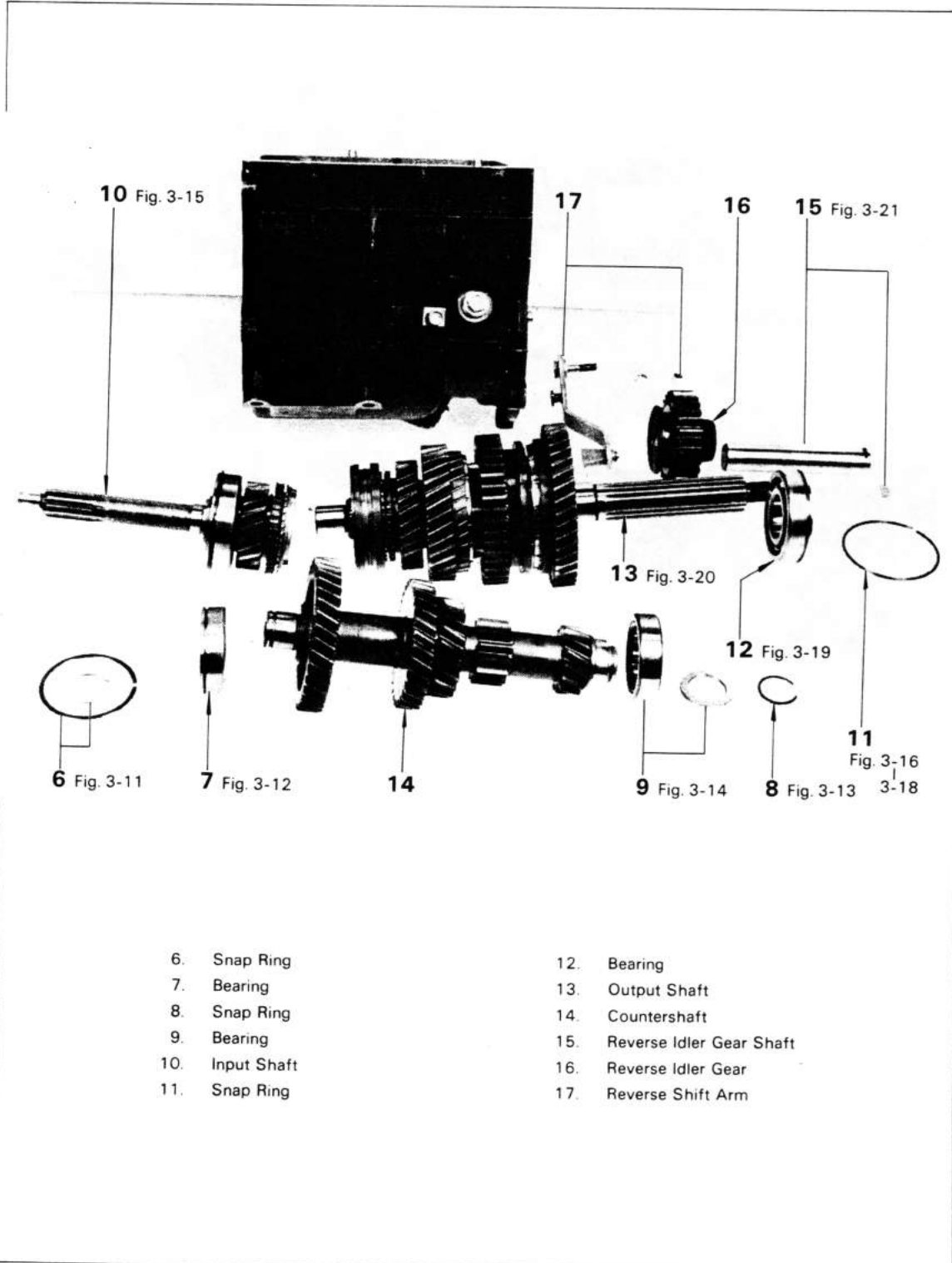

- Disassemble the parts in the numerical order shown in the figure.

Fig. 3-10

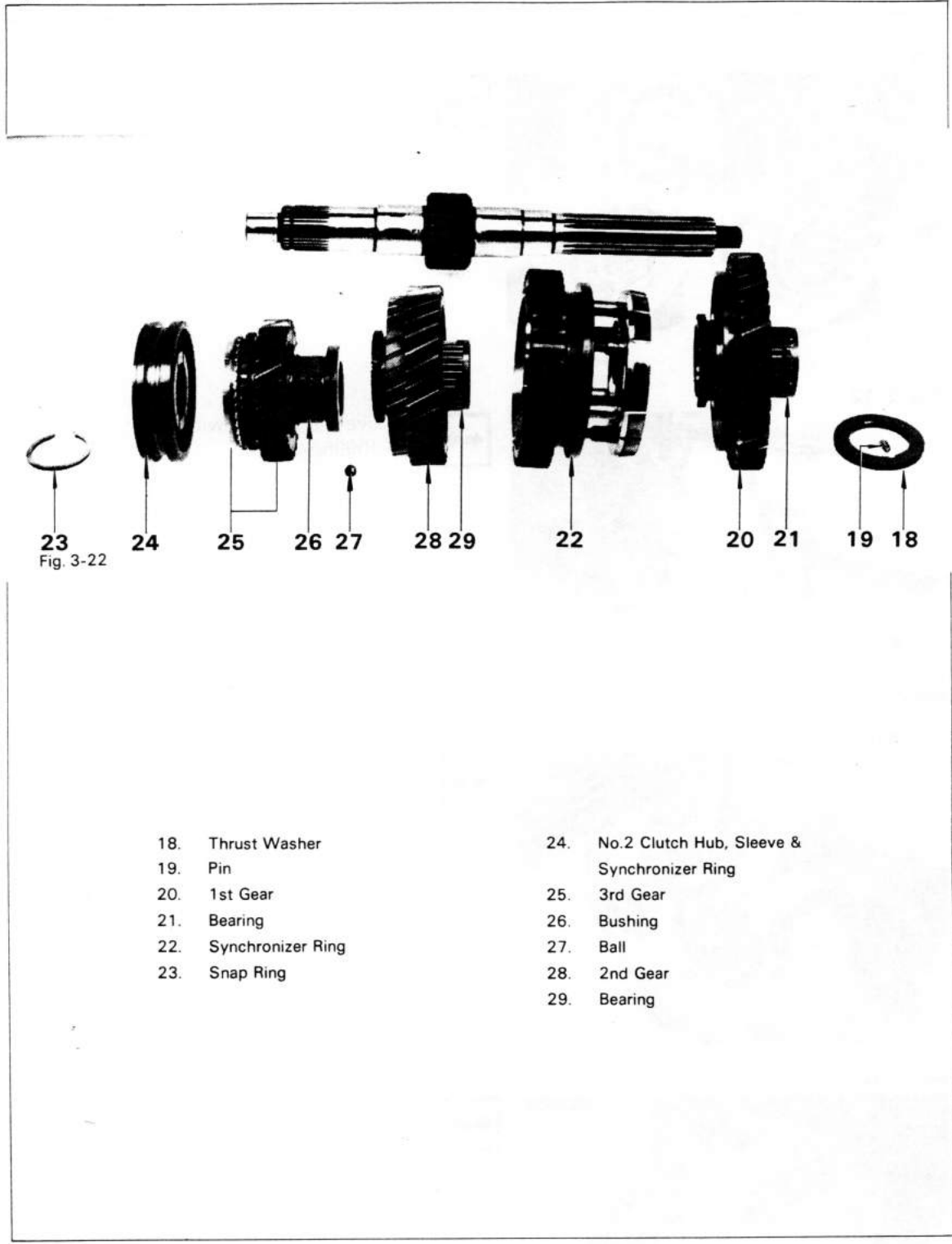

23  
Fig. 3-22

- 24      25      26      27      28 29      22      20 21      19 18

- |                       |   |
|-----------------------|---|
| 18. Thrust Washer     | 24. No.2 Clutch Hub, Sleeve & Synchronizer Ring |
| 19. Pin               | 25. 3rd Gear                                    |
| 20. 1st Gear          | 26. Bushing                                     |
| 21. Bearing           | 27. Ball  |
| 22. Synchronizer Ring | 28. 2nd Gear                                    |
| 23. Snap Ring         | 29. Bearing                                     |

Fig. 3-11

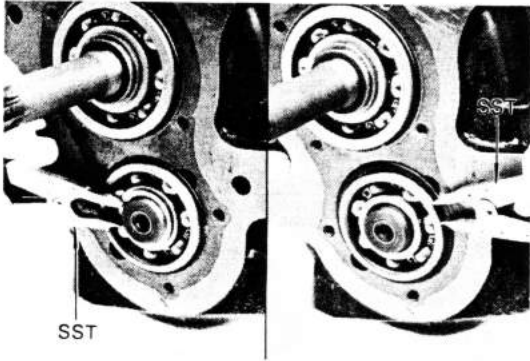

Remove the snap ring with SST.  
SST [09905-00012]

Fig. 3-12

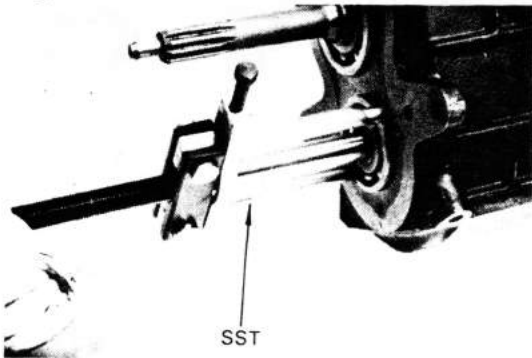

Remove the bearing with SST.  
SST [09950-20014]

Fig. 3-13

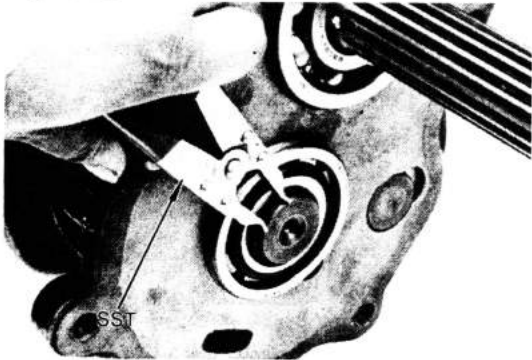

Remove the snap ring with SST.  
SST [09905-00012]

Fig. 3-14

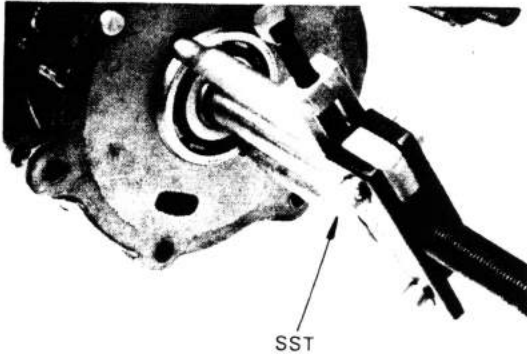

Remove the bearing with SST.  
SST [09950-20014]

Fig. 3-15

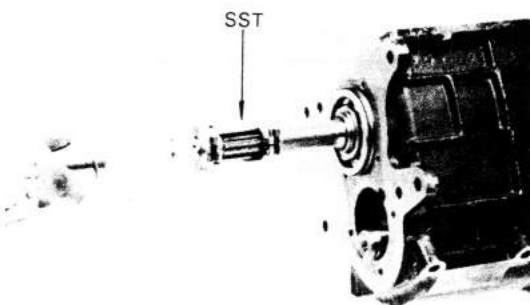

Remove the input shaft assembly from the case with SST.  
SST [09910-00014]

Fig. 3-16

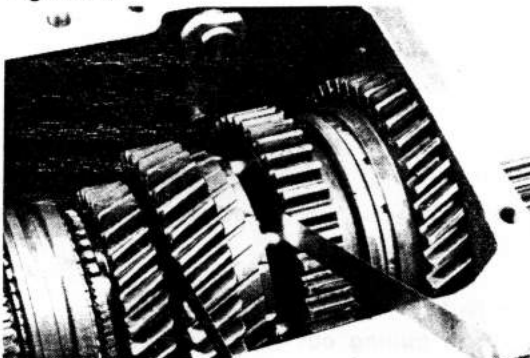

Measure the 3rd and 2nd gear thrust clearance.

**Thrust clearance:**

2nd STD	0.175 – 0.325 mm (0.0069 – 0.0128 in.)
Limit	0.35 mm (0.0138 in.)
3rd STD	0.125 – 0.275 mm (0.0049 – 0.0108 in.)
Limit	0.35 mm (0.0138 in.)

Fig. 3-17

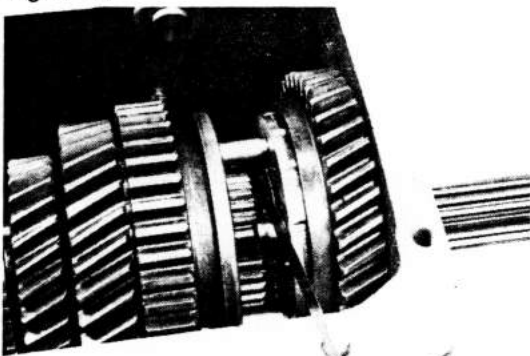

Measure the 1st gear and sleeve thrust clearance.

**Thrust clearance:**

STD	0.175 – 0.320 mm (0.0069 – 0.0126 in.)
Limit	0.32 mm (0.0126)

Fig. 3-18

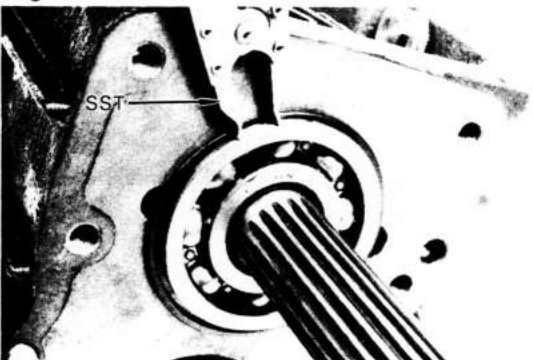

Remove the snap ring with SST.  
SST [09905-00012]

Fig 3-19

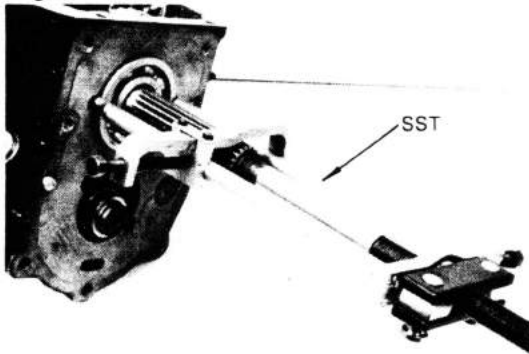

Remove the bearing with SST.  
SST [09950-20014]

Fig. 3-20

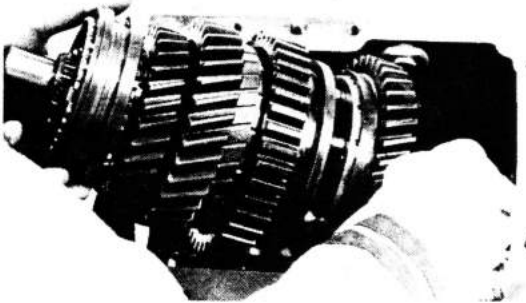

Hold the 1st gear tightly against the other gears and pull out the output shaft assembly from the case.

– Note –

When pulling out the assembly, hold the gears in place to keep them from sliding off the shaft.

Fig. 3-21



Drive out the reverse idler gear shaft toward the rear.

Fig. 3-22

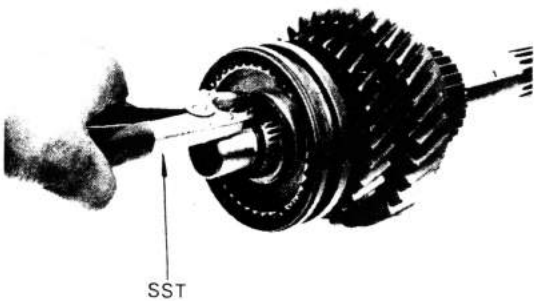

Remove the snap ring with SST.  
SST [09905-00012]

Fig. 3-23

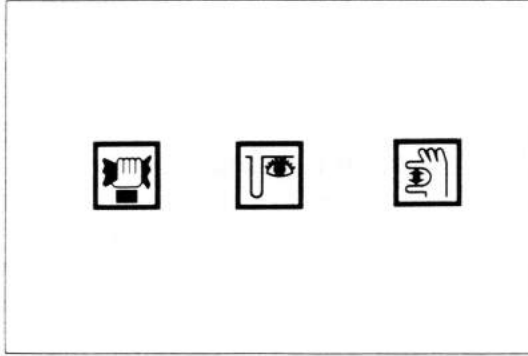
**INSPECTION**

Wash the disassembled parts and inspect them as described below. Replace any part found defective.

Fig. 3-24

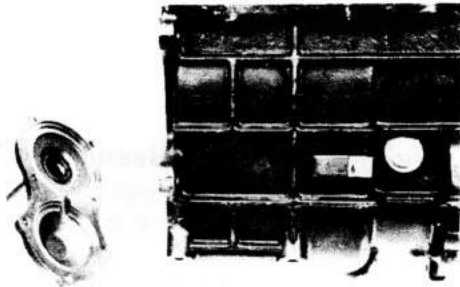
**Transmission Case & Front Bearing Retainer**

Inspect for wear or damage.

Fig. 3-25

**Replace The Front Bearing Retainer Oil Seal**

1. Remove the oil seal by prying with a driver.
2. Tap in the oil seal with SST.  
SST [09316-60010]

Fig. 3-26

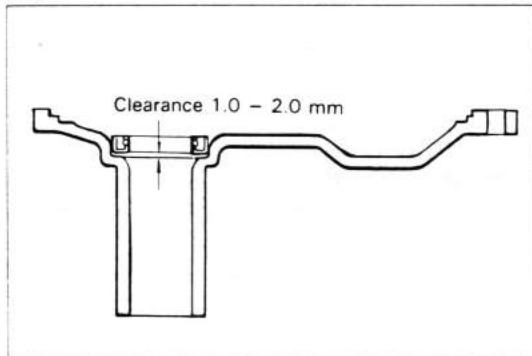

— Note —

Check the clearance between the oil seal front end and retainer.

Clearance: 1.0 - 2.0 mm  
(0.039 - 0.079 in)

Fig. 3-27

**Output Shaft & Bushing**

1. Inspect the shaft surfaces contacting the bearings and gears for wear or damage.
2. Inspect the bushing for wear or damage.

Fig. 3-28

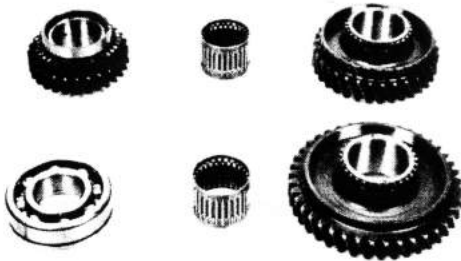
**1st, 2nd, 3rd Gear & Bearing**

1. Inspect the gears for wear or damage at the teeth, thrust faces, inside diameter, and coned surfaces.
2. Inspect the output shaft rear bearing and the roller bearings for wear or damage.

Fig. 3-29

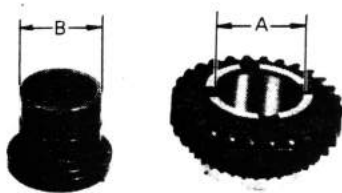

3. Measure the oil clearance.

**3rd gear oil clearance (A - B):**  
**STD** 0.065 - 0.115 mm  
 (0.0026 - 0.0045 in.)  
**Limit** 0.115 mm  
 (0.0045 in.)

Fig. 3-30

**Synchronizer Ring**

1. Fit the synchronizer ring on the gear and measure the clearance.

**3rd & 4th gear synchronizer ring clearance:**  
**Limit** 0.8 mm  
 (0.031 in.)

Fig. 3-31

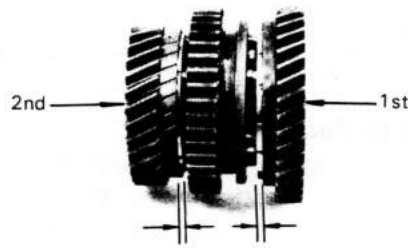

2. Measure the No.1 synchronizer ring dimension.

**Dimension:**

**Limit**

<b>1st gear</b>	<b>2.8 mm</b> <b>(0.110 in.)</b>
<b>2nd gear</b>	<b>1.8 mm</b> <b>(0.0110 in.)</b>

Fig. 3-32

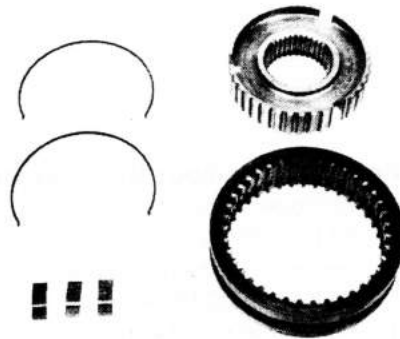

**Clutch Hub Sleeve, Clutch Hub, Shifting Key & Shifting Key Spring**

1. Disassemble the clutch hub and sleeve.
2. Inspect the splines of hub and hub sleeve for wear or damage.
3. Inspect the center humped part of keys for wear or damage.
4. Inspect the key springs for weakening or damage.

Fig. 3-33



5. Check the clearance between the sleeve and shift fork.

**Shift fork to hub sleeve clearance:**

<b>Limit</b>	<b>0.8 mm</b> <b>(0.031 in.)</b>
--------------	-------------------------------------

Fig. 3-34

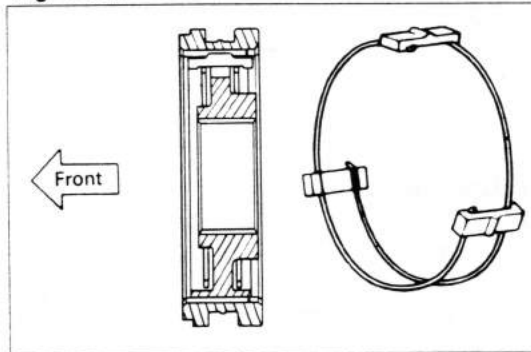

6. Hub and hub sleeve are parts having directionality. Install the key springs positioned so that their end gaps will not be in line.

cardiagn.com

Fig. 3-35

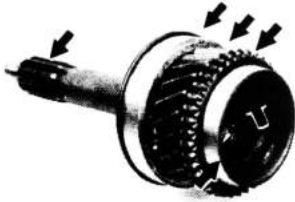
**Input Shaft**

1. Inspect the gear teeth, splines, coned surfaces, and bearing for wear or damage.
2. Inspect the shaft inner surface that contact on the needle roller bearing for wear or damage.

Fig. 3-36

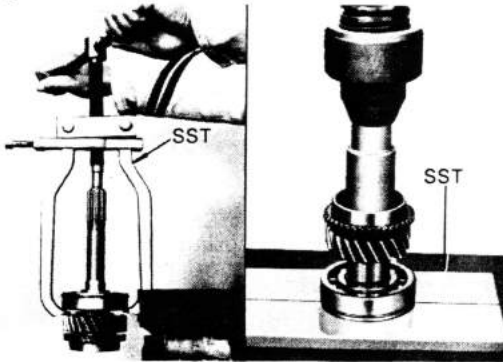
**Replace The Input Shaft Bearing**

1. Remove the snap ring with SST.  
SST [09905-00012]
2. Remove the bearing with SST.  
SST [09950-20014]
3. Install the new bearing with a press.

Fig. 3-37

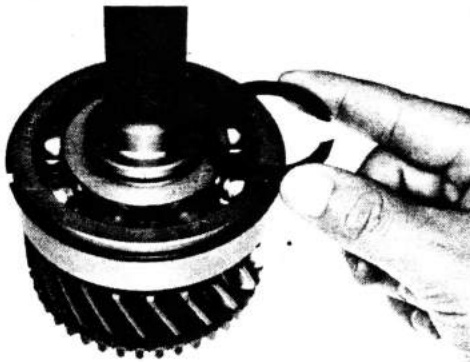

4. Select a snap ring of the thickness that will allow minimum axial play, and install it on the shaft.

Snap ring size

Part No.	Thickness	mm (in.)
90520-36015	3.31 – 3.42	(0.1303 – 0.1346)
90520-36016	3.20 – 3.31	(0.1260 – 0.1303)

Fig. 3-38

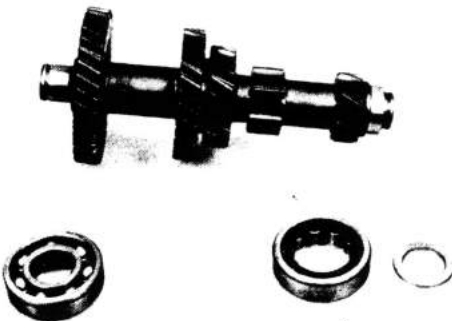
**Counter Gear**

1. Inspect the counter gear teeth for wear or damage.
2. Inspect the front and rear bearings for wear or damage.

Fig. 3-39

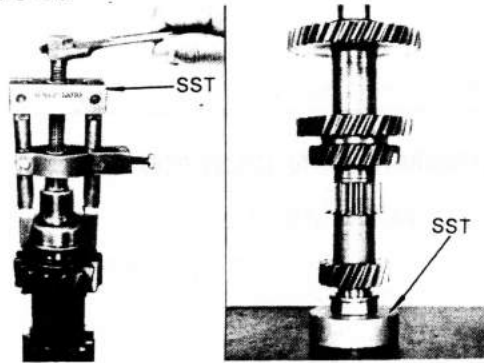

3. Rear bearing inner race replacement.
- (1) Remove the inner race with SST. SST [09602-10010]
  - (2) Install the new inner race with SST. SST [09515-21010]

— Note —

**Make sure to position the inner race so that its flanged side will be directed toward the front.**

Fig. 3-40

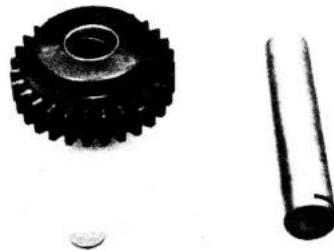

**Reverse Idler Gear, bushing & Shaft**

- 1. Inspect the gear, bushing, and shaft for wear or damage.

Fig. 3-41

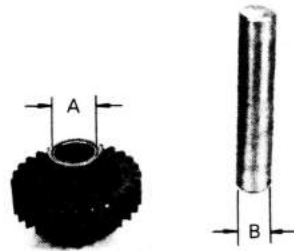

- 2. Measure the reverse idle gear gear bushing and shaft oil clearance.

**Oil clearance:**  
**Limit 0.16 mm**  
**(0.0063 in.)**

Fig. 3-42

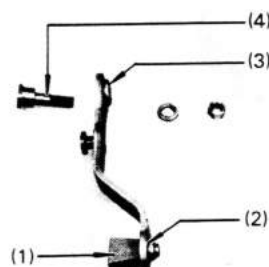

**Reverse Shift Arm**

- 1. Inspect the shift arm shoe(1) for wear or damage.

**Shoe thickness:**  
**Limit 8.1 mm**  
**(0.319 in.)**

- 2. Inspect the shift arm at the shoe mounting(2) and pivot mounting(3) for wear or damage.
- 3. Inspect the pivot(4) for wear or damage.
- 4. Inspect the clearance between the shoe and reverse idler gear slot.

**Clearance:**  
**Limit 0.7 mm**  
**(0.028 in.)**

### TRANSMISSION CASE COVER

#### DISASSEMBLY

Disassemble the parts in the numerical order shown in the figure.

Fig. 3-43

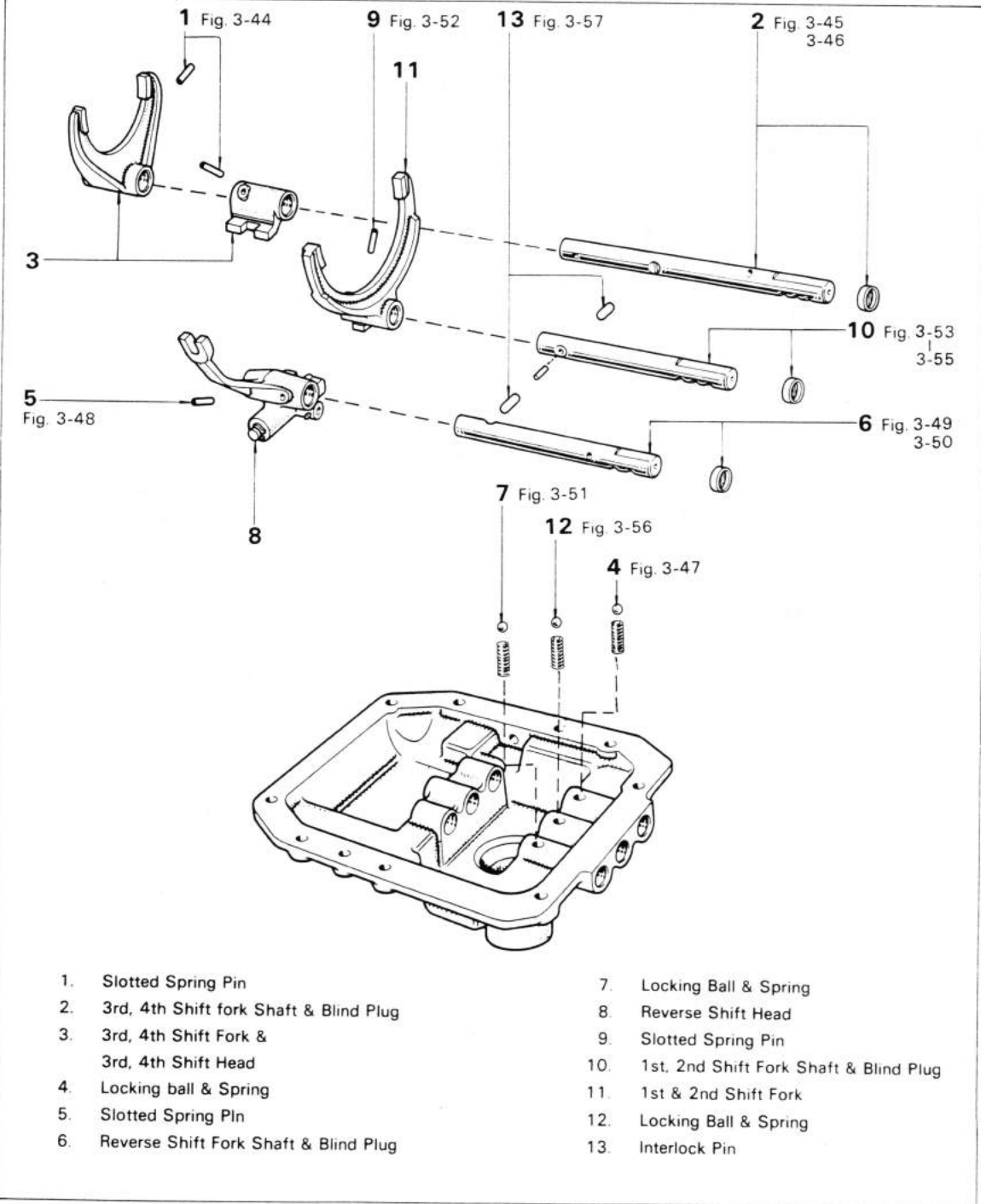

- |  |  |
|--|--|
| 1. Slotted Spring Pin                        | 7. Locking Ball & Spring                   |
| 2. 3rd, 4th Shift fork Shaft & Blind Plug    | 8. Reverse Shift Head                      |
| 3. 3rd, 4th Shift Fork & 3rd, 4th Shift Head | 9. Slotted Spring Pin                      |
| 4. Locking ball & Spring                     | 10. 1st, 2nd Shift Fork Shaft & Blind Plug |
| 5. Slotted Spring Pin                        | 11. 1st & 2nd Shift Fork                   |
| 6. Reverse Shift Fork Shaft & Blind Plug     | 12. Locking Ball & Spring                  |
|  | 13. Interlock Pin                          |

Fig. 3-44

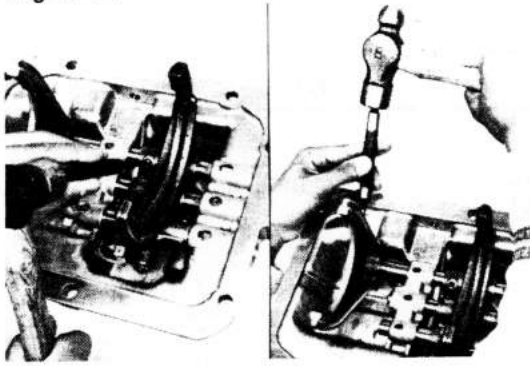

Drive out the slotted spring pin.

Fig. 3-45

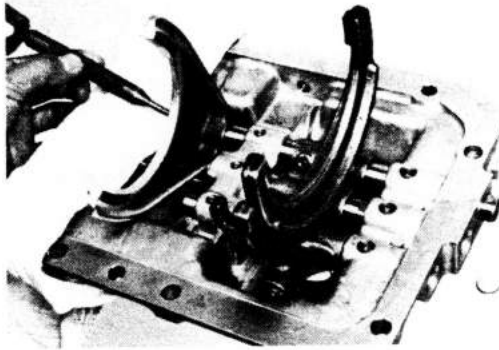

Drive out the shift fork shaft together with the blind plug.

— Note —  
Do not damage the case cover.

Fig. 3-46

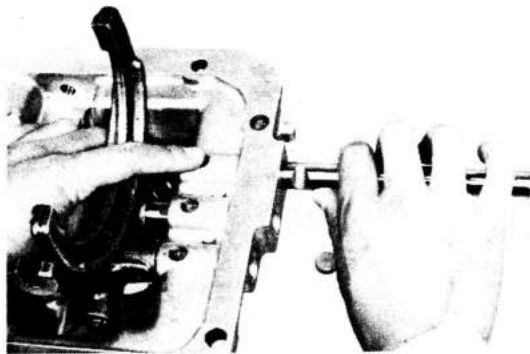

Cover the service hole with your hand to prevent locking ball from flying out.

Fig. 3-47

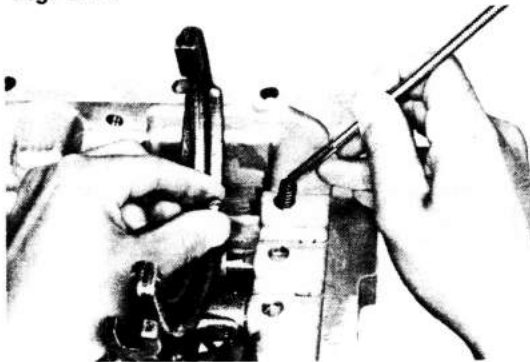

Remove the locking ball and the spring with magnet.

Fig. 3-48

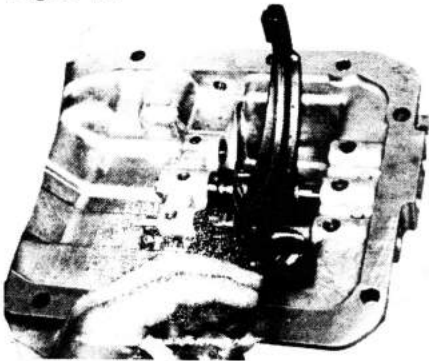

Drive out the slotted spring pin.

Fig. 3-49

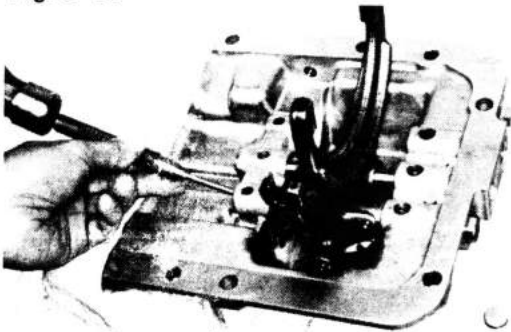

Drive out the shift fork shaft together with blined plug.

Fig. 3-50

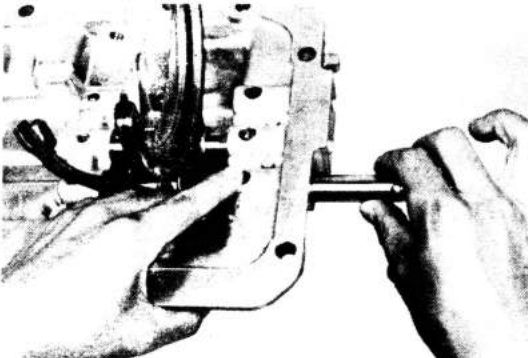

Cover the service hole with your hand to prevent the locking ball from flying out.

Fig. 3-51

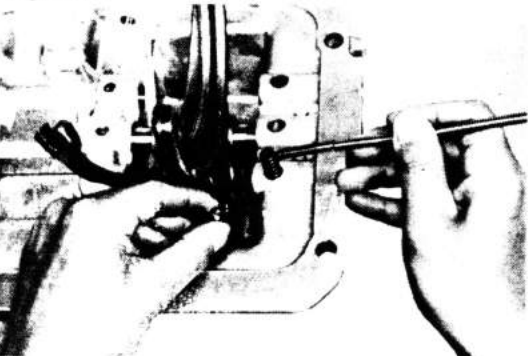

Remove the locking ball and the spring with magnet.

Fig. 3-52

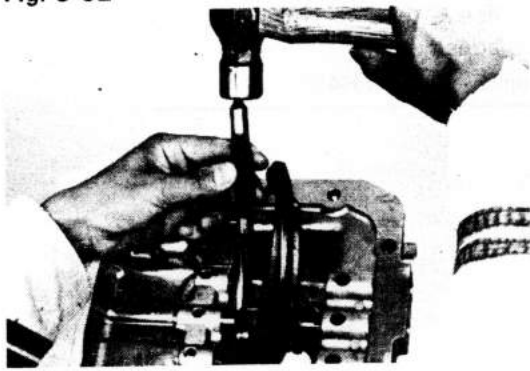

Drive out the slotted spring pin.

Fig. 3-53

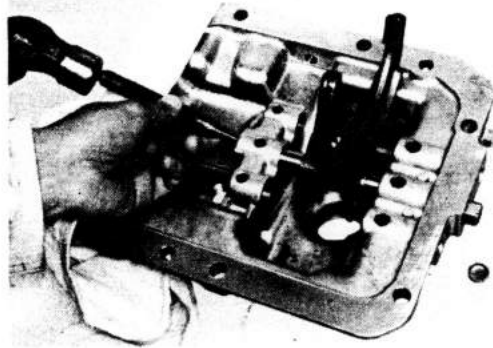

Drive out the fork shaft together with the blind plug.

Fig. 3-54

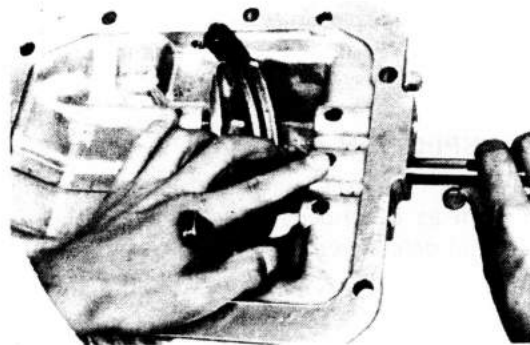

Cover the service hole with your hand to prevent locking ball from flying out.

Fig. 3-55



Remove the interlock pin with magnet.

Fig. 3-56

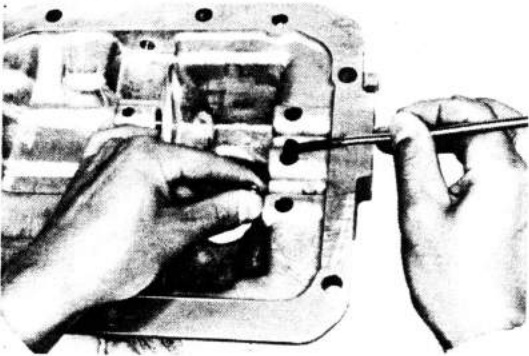

Remove the locking ball and the spring with magnet.

Fig. 3-57

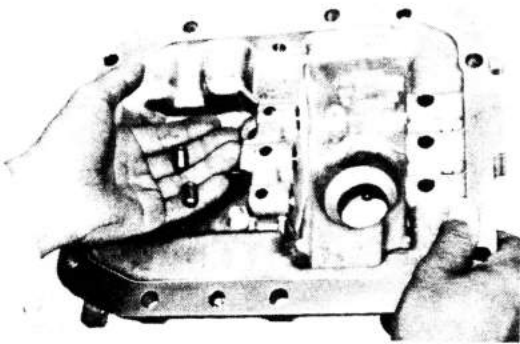

Remove the interlock pins from the case cover.

Fig. 3-58

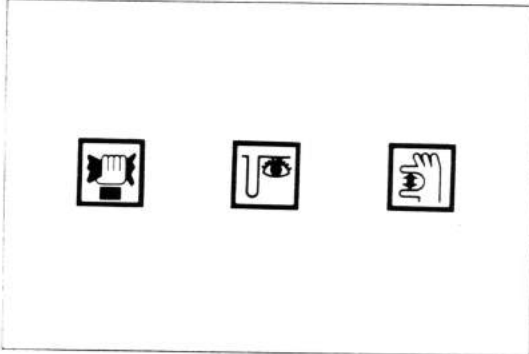

### INSPECTION & REPAIR

Wash the disassembled parts and inspect them as described below. Replace any part found defective.

Fig. 3-59



### Shift Lever

1. Check the sliding action of the lever.
2. Coat MP grease on the shift lever.

Fig. 3-60

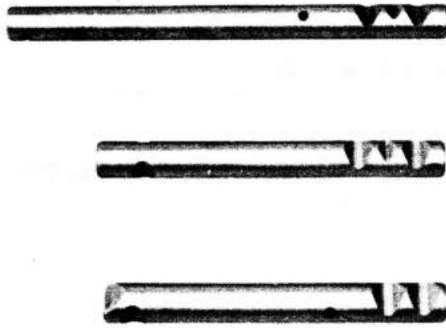

**Shift Fork Shaft**

1. Check for wear or damage.

Fig. 3-61

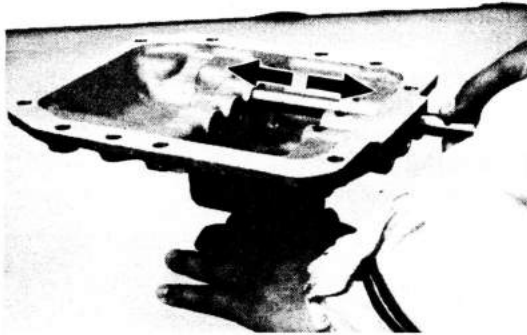

2. Check the sliding action against the case.

Fig. 3-62



**Shift Fork**

Check for wear or damage.

Fig. 3-63

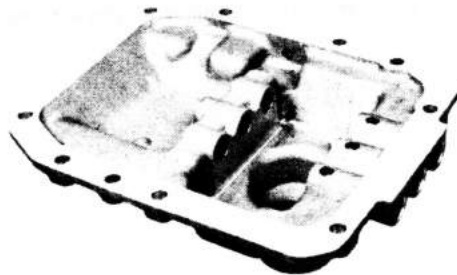

**Case**

Check for cracks or damage.

Fig. 3-64

**Interlock Pin & Slotted Spring Pin**

Check for wear or damage.

Fig. 3-65

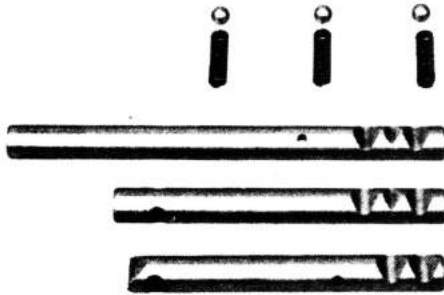
**Locking Ball**

Check for wear or damage.

Fig. 3-66

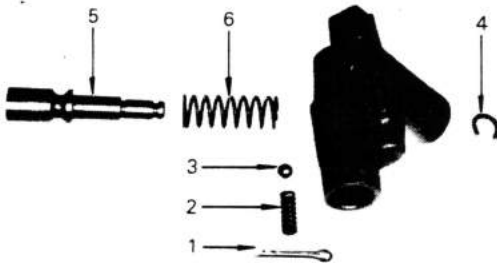
**Reverse Shift Head**

1. Disassemble the shift head in the numerical order shown in the figure.
2. Reassemble in reverse sequence of disassembly.

**— Note —**

1. After installing the C washer, bend both ends inward.
2. Verify that the plunger slides smoothly.

**ASSEMBLY**

Assemble the parts in the numerical order shown in the figure.

**Fig. 3-67**

— Note —

Apply gear oil to all sliding, rotating and engaging parts of the transmission before assembling them.

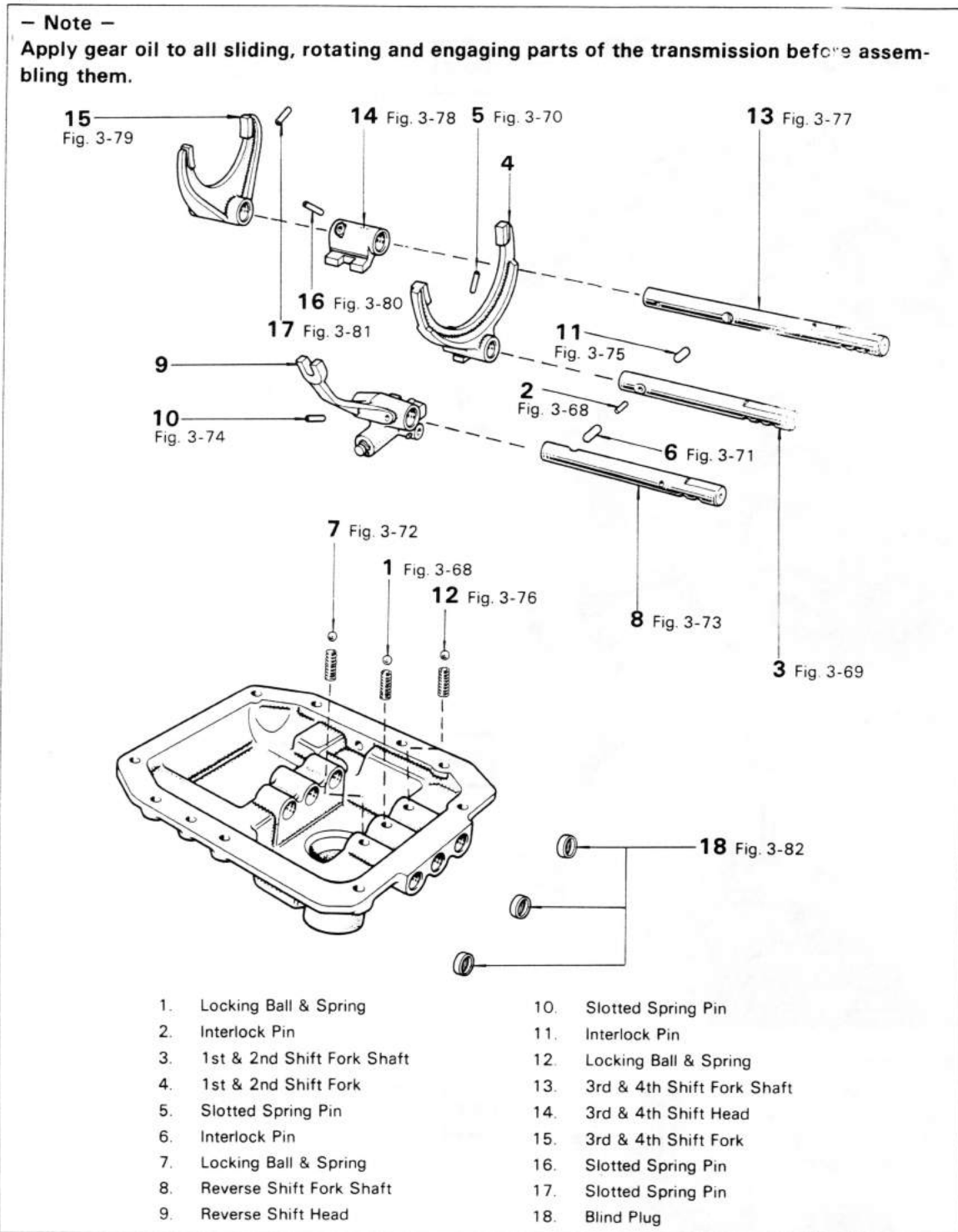

- |                               |                                |
|-------------------------------|--------------------------------|
| 1. Locking Ball & Spring      | 10. Slotted Spring Pin         |
| 2. Interlock Pin              | 11. Interlock Pin              |
| 3. 1st & 2nd Shift Fork Shaft | 12. Locking Ball & Spring      |
| 4. 1st & 2nd Shift Fork       | 13. 3rd & 4th Shift Fork Shaft |
| 5. Slotted Spring Pin         | 14. 3rd & 4th Shift Head       |
| 6. Interlock Pin              | 15. 3rd & 4th Shift Fork       |
| 7. Locking Ball & Spring      | 16. Slotted Spring Pin         |
| 8. Reverse Shift Fork Shaft   | 17. Slotted Spring Pin         |
| 9. Reverse Shift Head         | 18. Blind Plug                 |

Fig. 3-68

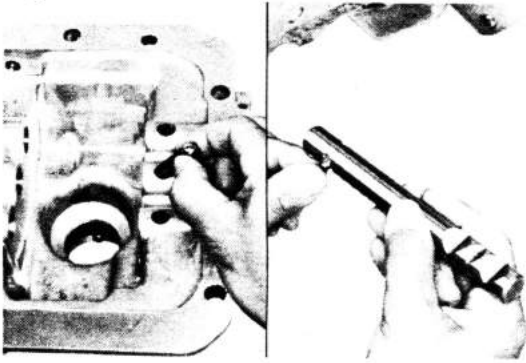

Install the spring and ball.  
Install the interlock pin on the shift fork shaft with MP grease.

Fig. 3-69

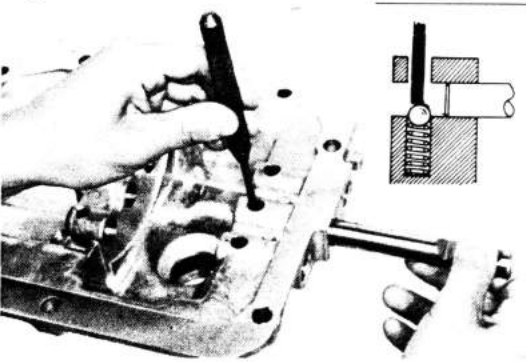

Insert the shift fork shaft over the locking ball.

Fig. 3-70

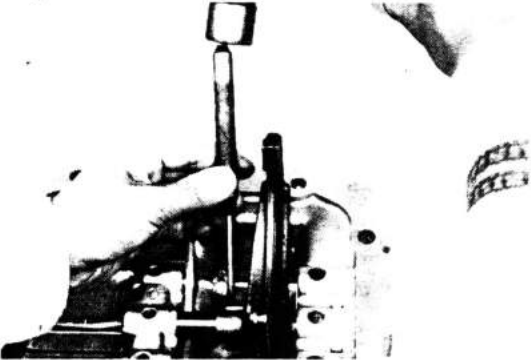

Drive in the slotted spring pin.

Fig. 3-71

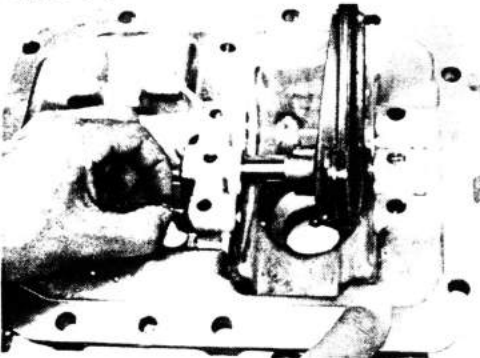

Install the interlock pin with MP grease.

Fig. 3-72

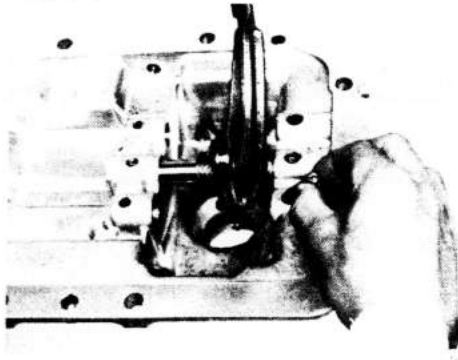

Install the spring and locking ball.

Fig. 3-73

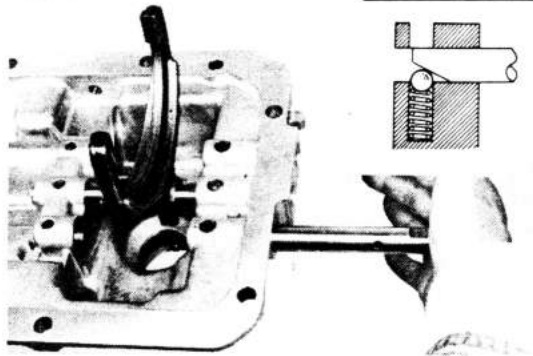

Insert the shift fork shaft over the locking ball.

Fig. 3-74

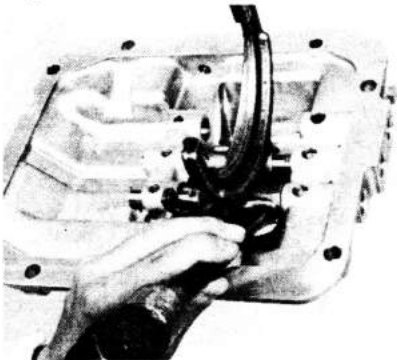

Install the slotted spring pin.

Fig. 3-75

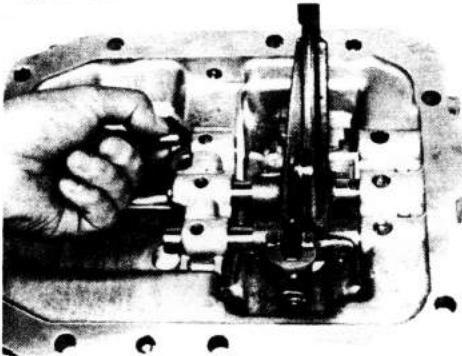

Install the interlock pin with MP grease.

Fig. 3-76

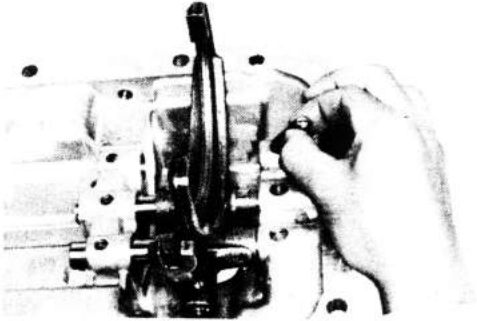

Install the spring and locking ball.

Fig. 3-77

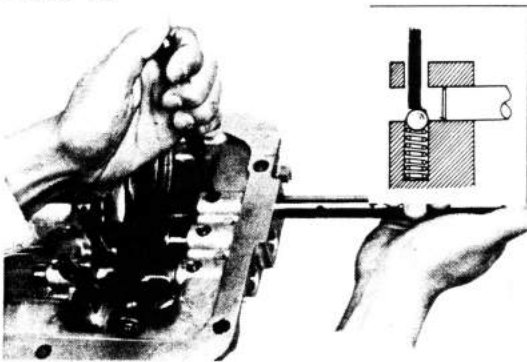

Insert the shift fork over the locking ball.

Fig. 3-78

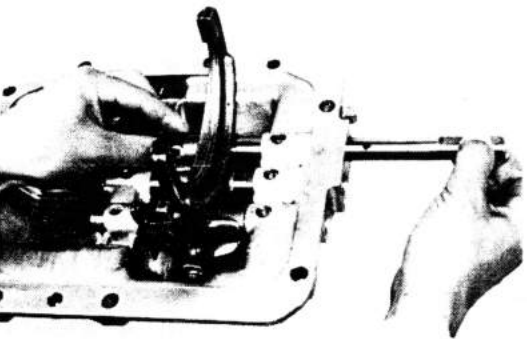

Install the shift head.

Fig. 3-79

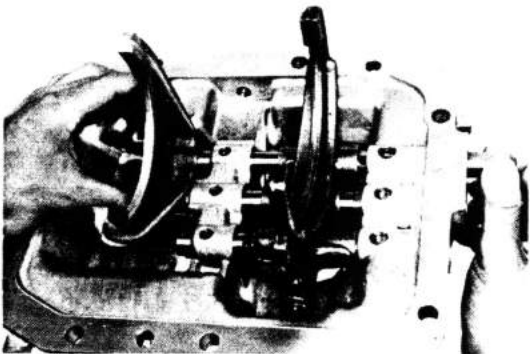

Install the shift fork.

Fig. 3-80

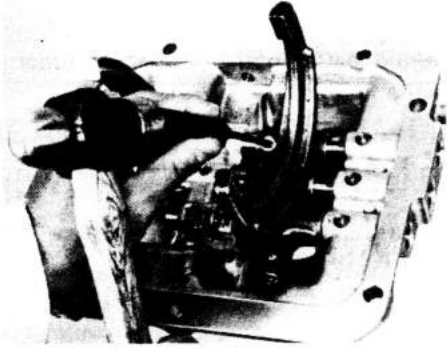

Install the slotted spring pin.

Fig. 3-81

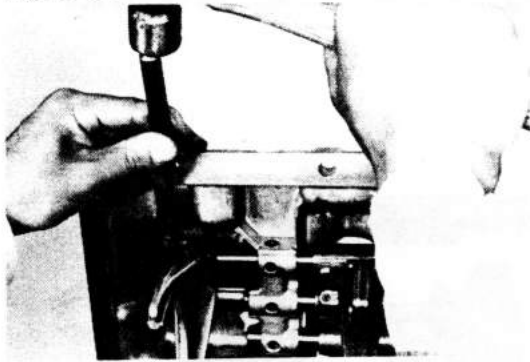

Install the slotted spring pin.

Fig. 3-82

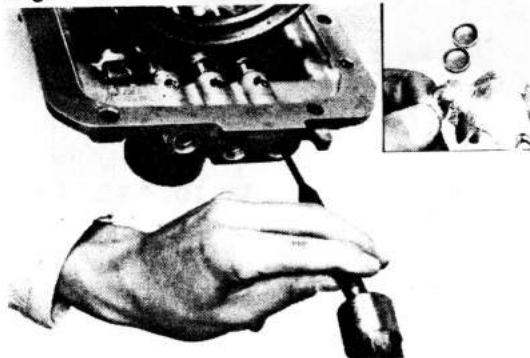

Apply liquid sealer to the blind plug before assembly.

## TRANSMISSION GEAR &amp; CASE

## ASSEMBLY

Assemble the parts in the numerical order shown in the figure.

Fig. 3-83

— Note —

Apply gear oil to all sliding, rotating and engaging parts of the transmission before assembling them.

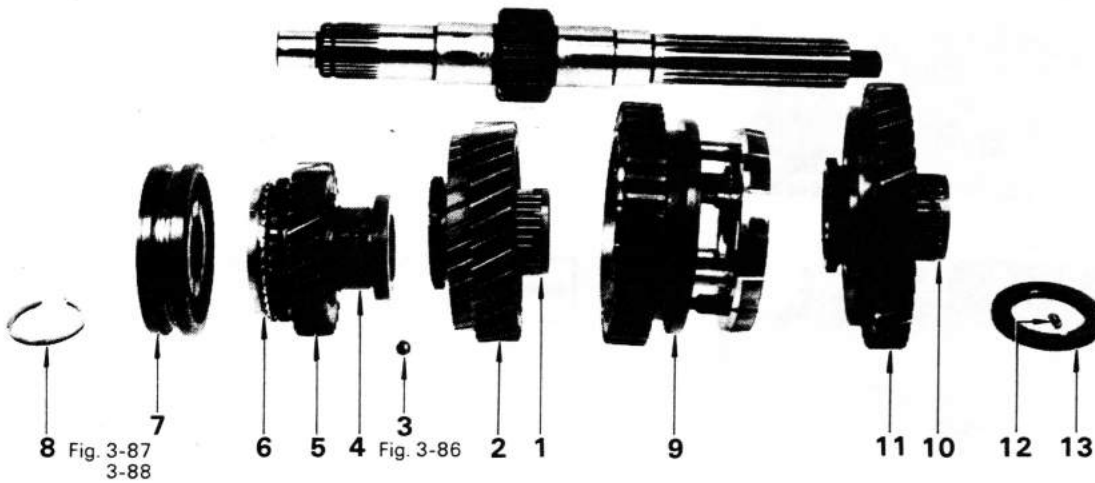

- |                             |                          |
|-----------------------------|--------------------------|
| 1. Bearing                  | 8. Snap Ring             |
| 2. 2nd Gear                 | 9. No.1 Synchronzer Ring |
| 3. Locking Ball             | 10. Bearing              |
| 4. Bushing                  | 11. 1st Gear             |
| 5. 3rd Gear                 | 12. Pin                  |
| 6. Synchronizer Ring        | 13. Thrust Washer        |
| 7. No.2 Clutch Hub & Sleeve |                          |

2. Assemble the parts in the numerical order shown in the figure.

Fig. 3-84

— Note —

Apply gear oil to all sliding, rotating and engaging parts of the transmission before assembling them.

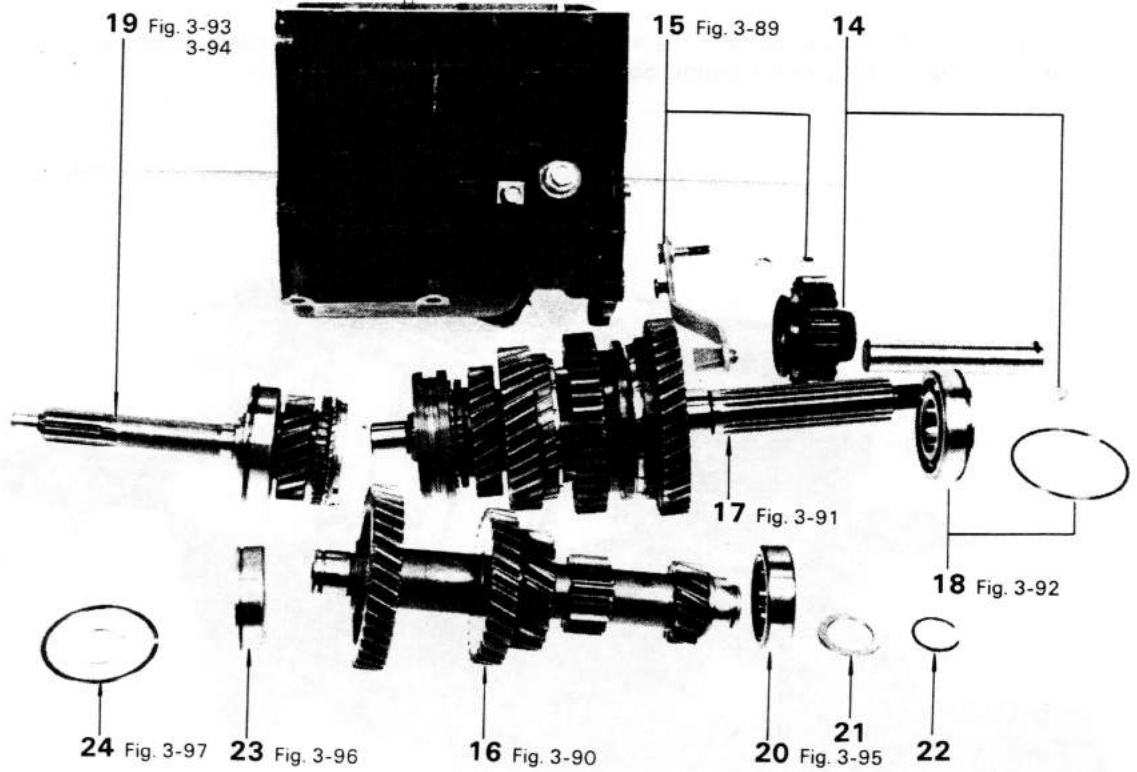

- |     |  |     |           |
|-----|--|-----|-----------|
| 14. | Idler Gear, Shaft & Key                  | 20. | Bearing   |
| 15. | Shift Arm                                | 21. | Retainer  |
| 16. | Countershaft                             | 22. | Snap Ring |
| 17. | Output Shaft                             | 23. | Bearing   |
| 18. | Bearing                                  | 24. | Snap Ring |
| 19. | Input Shaft, Bearing & Synchronizer Ring |     |           |

3. Assemble the parts in the numerical order shown in the figure.

Fig. 3-85

**— Note —**

Apply gear oil to all sliding, rotating and engaging parts of the transmission, and coat liquid sealer on the gaskets and through bolts before assembling them.

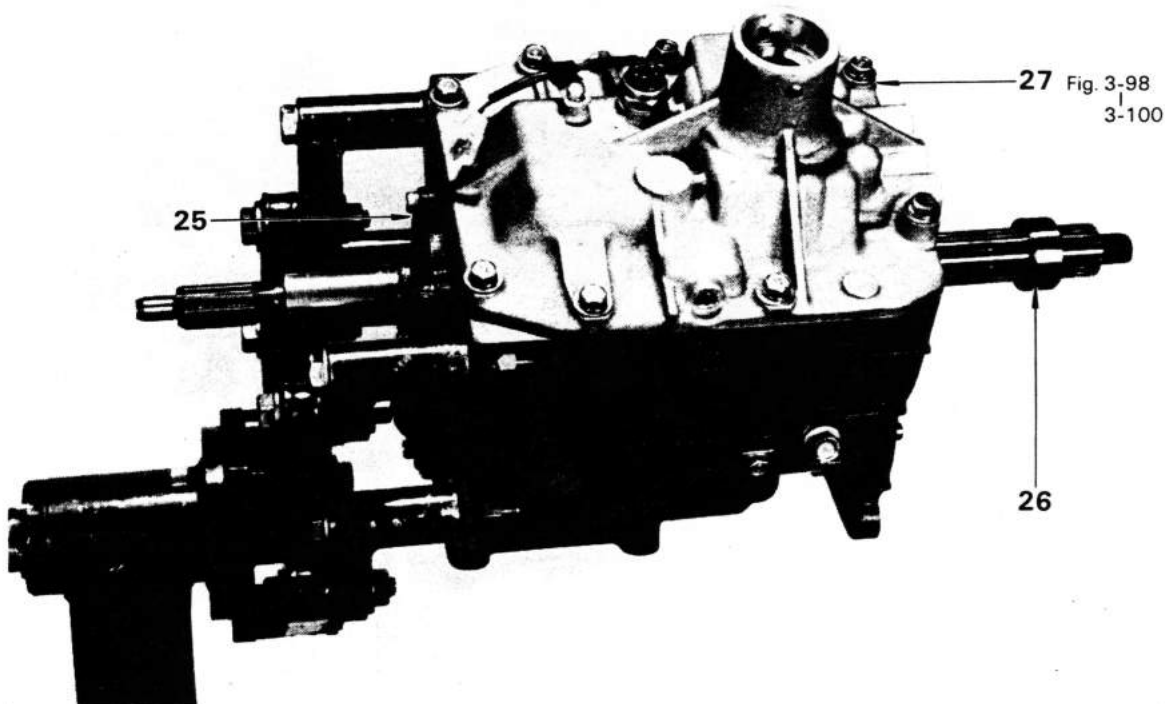

25. Front Bearing Retainer
26. Spacer
27. Case Cover

Fig. 3-86

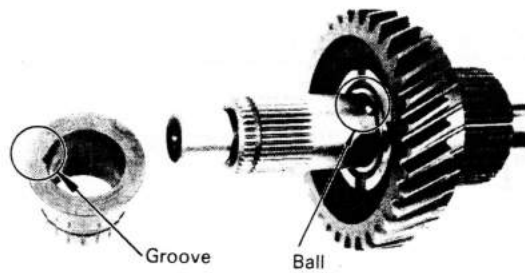

Align the bushing groove with the ball, and install the bushing to the output shaft.

Fig. 3-87

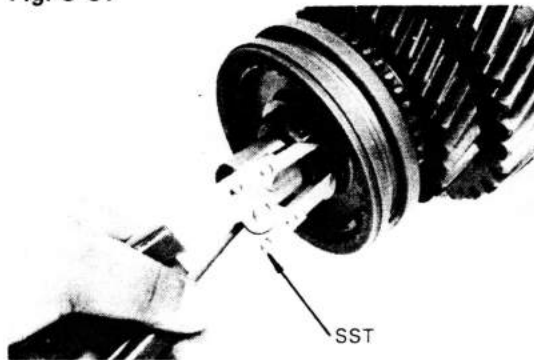

Select a snap ring of the thickness that will reduce the clearance to a minimum.

Snap ring thickness

Mark	Thickness mm (in.)
0	2.40 - 2.45 (0.0945 - 0.0965)
1	2.45 - 2.50 (0.0965 - 0.0984)
2	2.50 - 2.55 (0.0984 - 0.1004)
3	2.55 - 2.60 (0.1004 - 0.1024)
4	2.60 - 2.65 (0.1024 - 0.1043)
5	2.65 - 2.70 (0.1043 - 0.1063)

Fig. 3-88

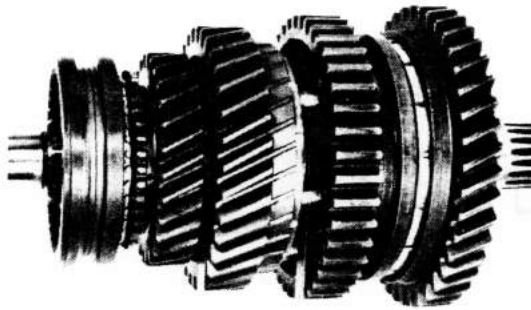

Measure the 2nd and 3rd gear thrust clearances.

**Thrust clearance:**

**2nd gear**

STD 0.175 - 0.0325 mm  
(0.0069 - 0.0128 in.)

Limit 0.35 mm  
(0.0138 in.)

**3rd gear**

STD 0.125 - 0.275 mm  
(0.0049 - 0.0108 in.)

Limit 0.35 mm  
(0.0138 in.)

Fig. 3-89

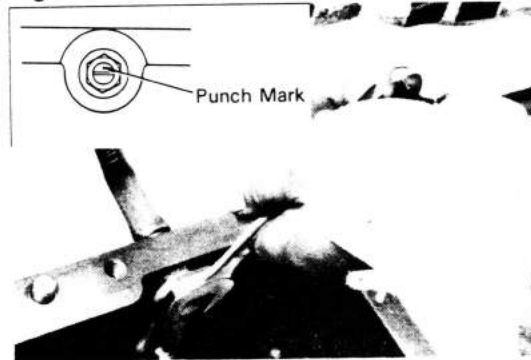

Lock the nut when the punch mark on the shift arm pivot is positioned straight up.

cardiagn.com

Fig. 3-90

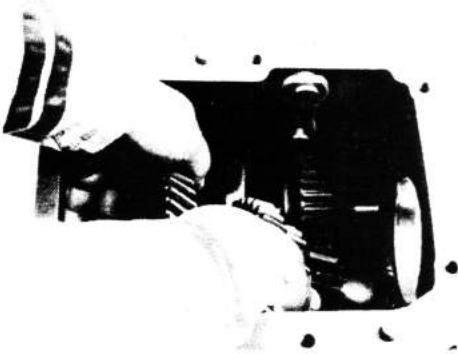

Lay the countershaft on the bottom of the transmission case.

Fig. 3-91

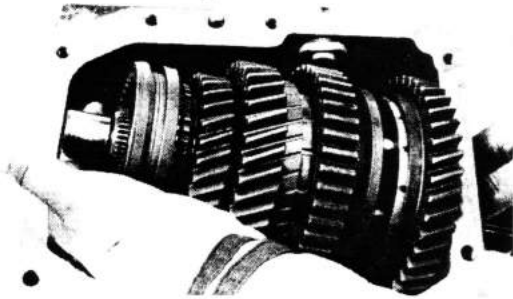

Install the output shaft assembly into the case.

Fig. 3-92

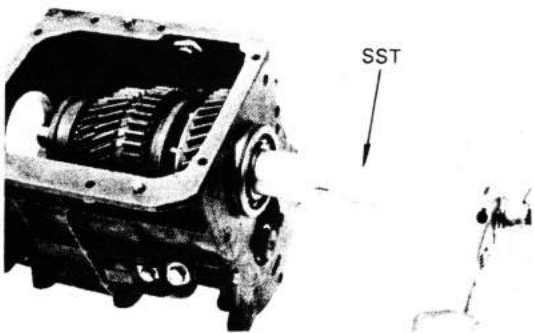

Install the bearing with SST.  
SST [09309-36032]

Fig. 3-93

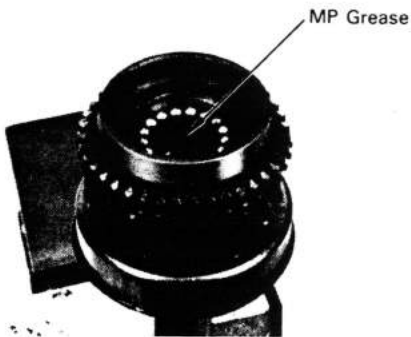

Apply MP grease to the input shaft and assemble the 17 bearing rollers.

Fig. 3-94

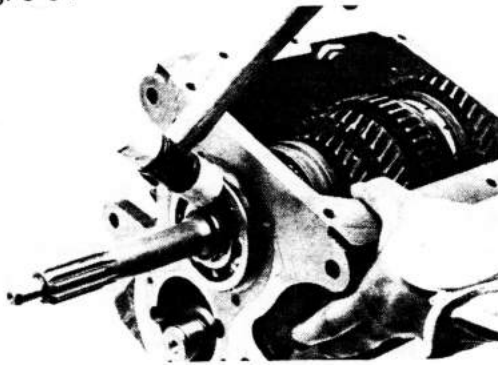

Drive in the input shaft to the case with a plastic hammer.

— Note —

Use care not to damage the synchronizer ring.

Fig. 3-95

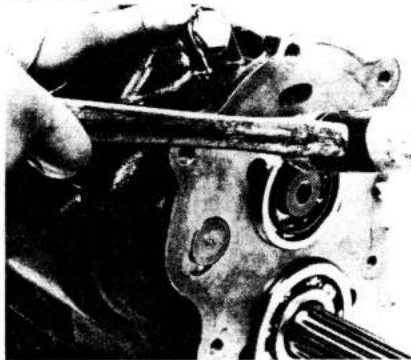

Lift up the countershaft to proper position and install the rear bearing with a plastic hammer.

Fig. 3-96

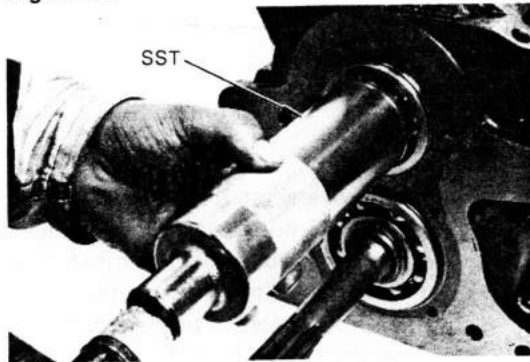

Install the bearing with SST.  
SST [09316-60010]

— Note —

Install the front and rear bearings by striking them alternately with a hammer.

Fig. 3-97

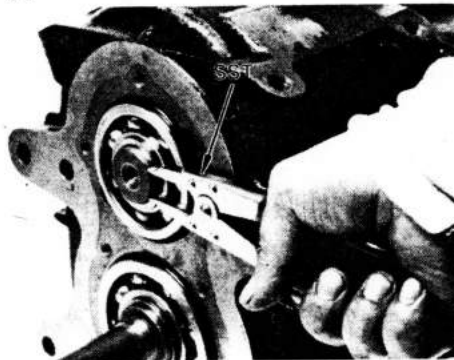

From the table below, select the thickness snap ring that will fit properly on the shaft, and install it with SST.  
SST [09905-00012]

Snap ring thickness

Mark	Thickness mm (in.)
0	2.05 – 2.10 (0.0807 – 0.0827)
2	2.15 – 2.20 (0.0846 – 0.0866)
4	2.25 – 2.30 (0.0886 – 0.0906)

Fig. 3-98

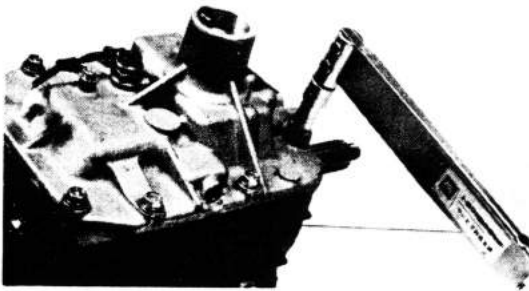

Tighten the case cover set bolts to the specified torque.

**Tightening torque: 3.0–4.5 kg-m  
(22–32 ft-lb)**

– Note –

**Have the case cover assembly and the gears in neutral position before installation.**

Fig. 3-99

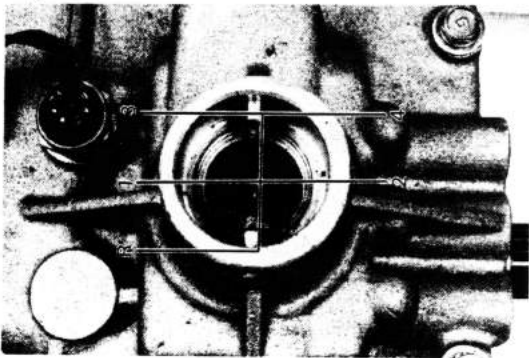

Install the shift lever temporarily, and while turning the input shaft, check the shifting and output shaft rotational relationship.

Fig. 3-100

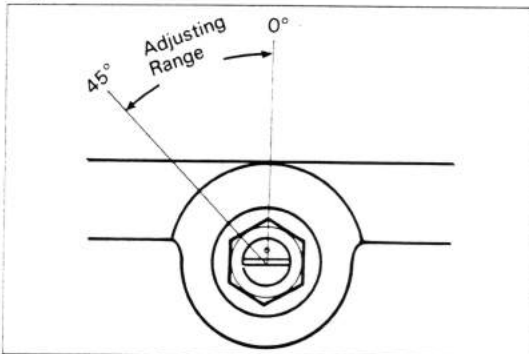

Adjust the reverse shift link.

1. Verify that no abnormal noise develops when the input shaft is turned or when the gear is shifted into reverse.
2. If abnormal noise is produced, correct by adjusting the shift link within a range of zero to 45° of the marker point.

4. Assemble the parts in the numerical order shown in the figure.

Fig. 3-101

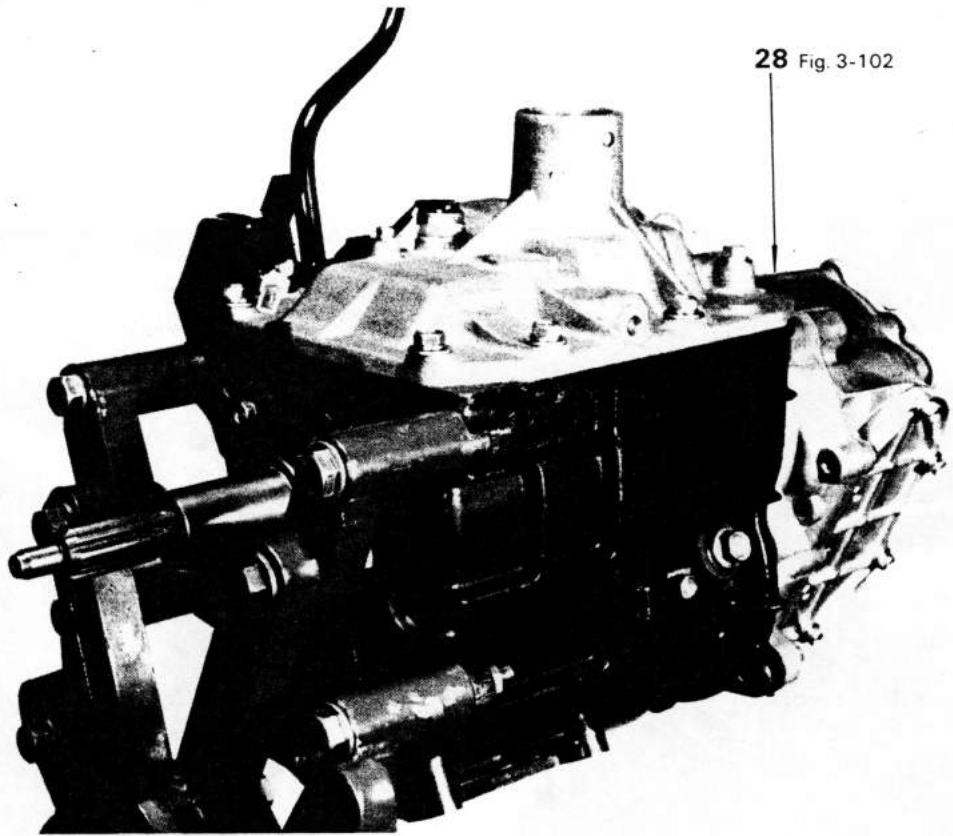

28 Fig. 3-102

28. Transfer

Fig. 3-102

**SEE  
TRANSFER ASSEMBLY  
SECTION  
Fig. 4-45 to 4-88**

Install the transfer.

## INSTALLATION

1. Install the parts in the numerical order shown in the figure.

Fig. 3-103

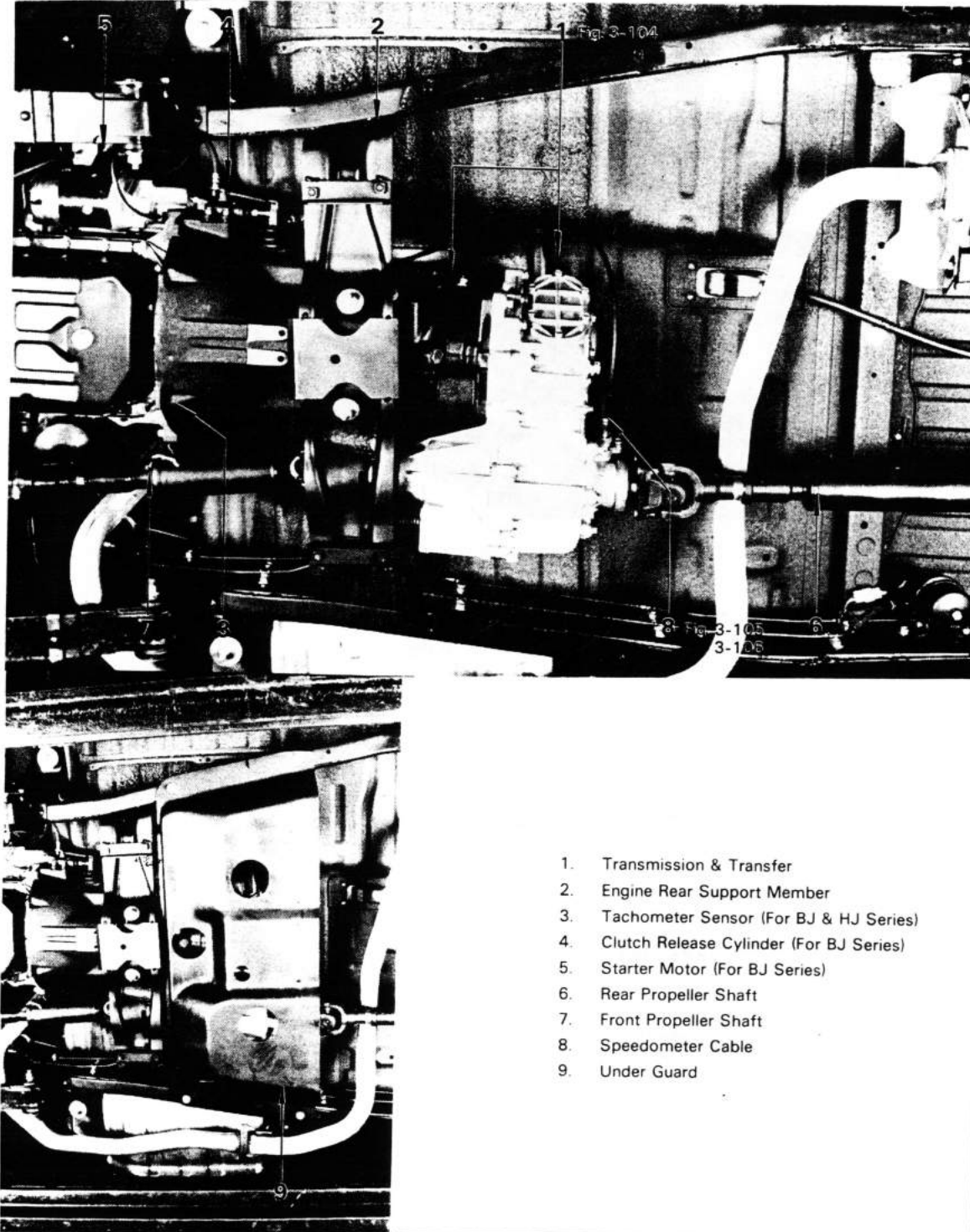

1. Transmission & Transfer
2. Engine Rear Support Member
3. Tachometer Sensor (For BJ & HJ Series)
4. Clutch Release Cylinder (For BJ Series)
5. Starter Motor (For BJ Series)
6. Rear Propeller Shaft
7. Front Propeller Shaft
8. Speedometer Cable
9. Under Guard

Fig. 3-104

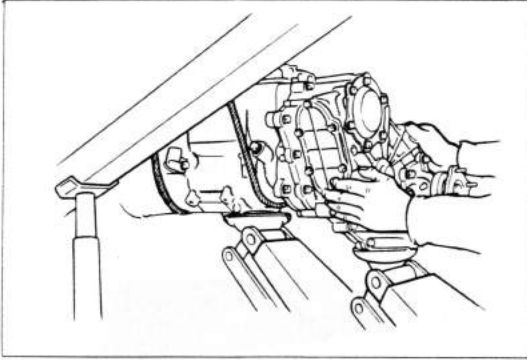

Support the transmission and transfer assembly with a jack and rope, and install.

**Tightening torque: 5.0 – 8.0 kg-m  
(37 – 57 ft-lb)**

Fig. 3-105



Fill the transmission and transfer with gear oil.

**Transmission oil capacity:**

**3.1 liters (3.3 US qt., 2.7 Imp. qt.)**

**Type: SAE90, API GL-4 or GL-5**

Fig. 3-106



**Transfer oil capacity:**

**w/o Power take off**

**2.5 liters (2.6 US qt., 2.2 Imp. qt.)**

**w/ Power take off**

**3.1 liters (3.3 US qt., 2.7 Imp. qt.)**

**Type: SAE90, API GL-4 or GL-5**

2. Install the parts in the numerical order shown in the figure.

Fig. 3-107

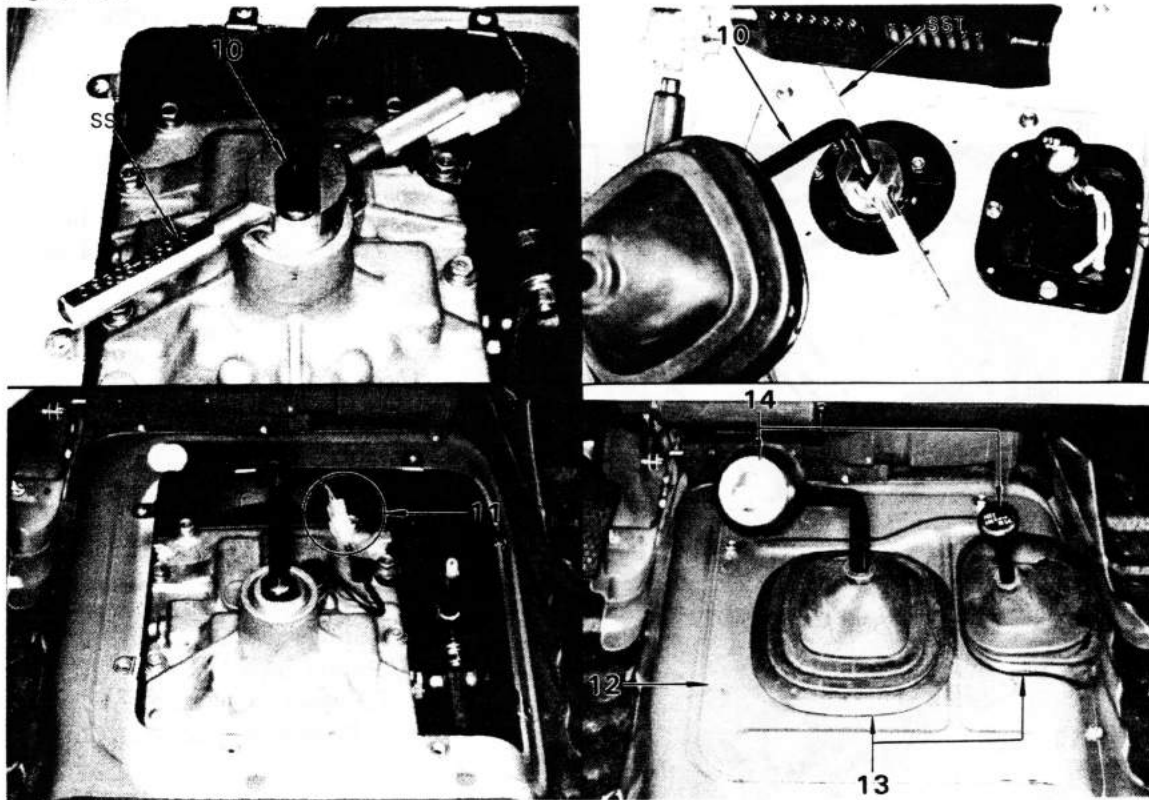

10. Shift Lever  
SST [09305-55010]
11. Back-up Light Switch Connector
12. Service Hole Cover
13. Boot
14. Knob

3. Install the parts in the numerical order shown in the figure.

Fig. 3-108

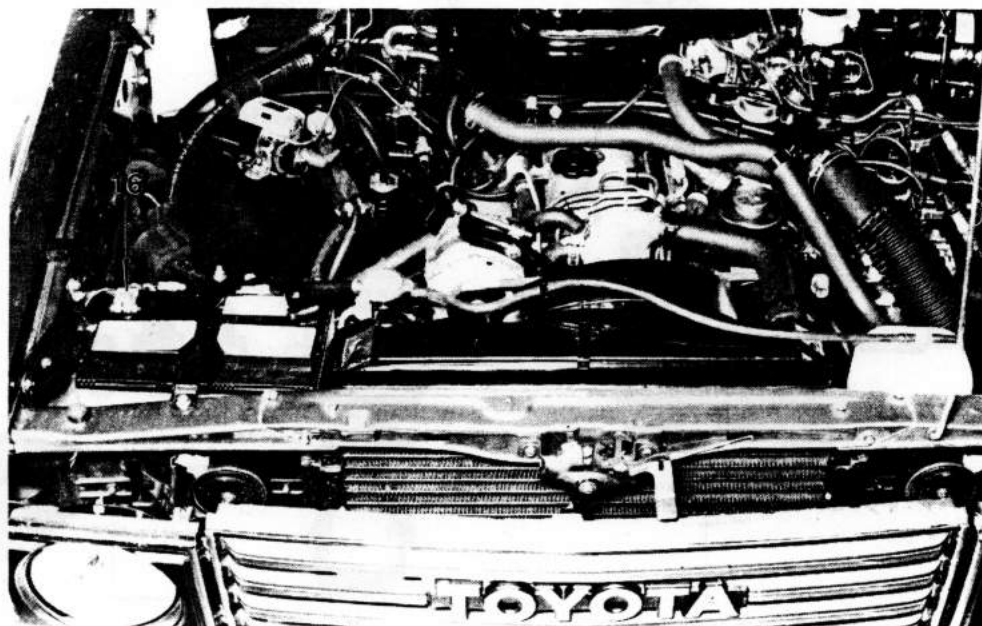

- |                    |                      |
|--------------------|----------------------|
| 15. Carpet or Mat  | 18. Scuff Plate      |
| 16. Heater Duct    | 19. Battery Terminal |
| 17. Cowl Side Trim |                      |

Fig. 3-109

**SEE  
4-SPEED TRANSMISSION  
REMOVAL SECTION  
Fig. 3-2 to 3-5**

### 3-SPEED TRANSMISSION (J30)

#### REMOVAL

1. Remove the transmission with transfer from the vehicle.
2. Drain the transmission and transfer oil.
3. Remove the transfer to the transmission in the numerical order shown in the figure.

Fig. 3-110

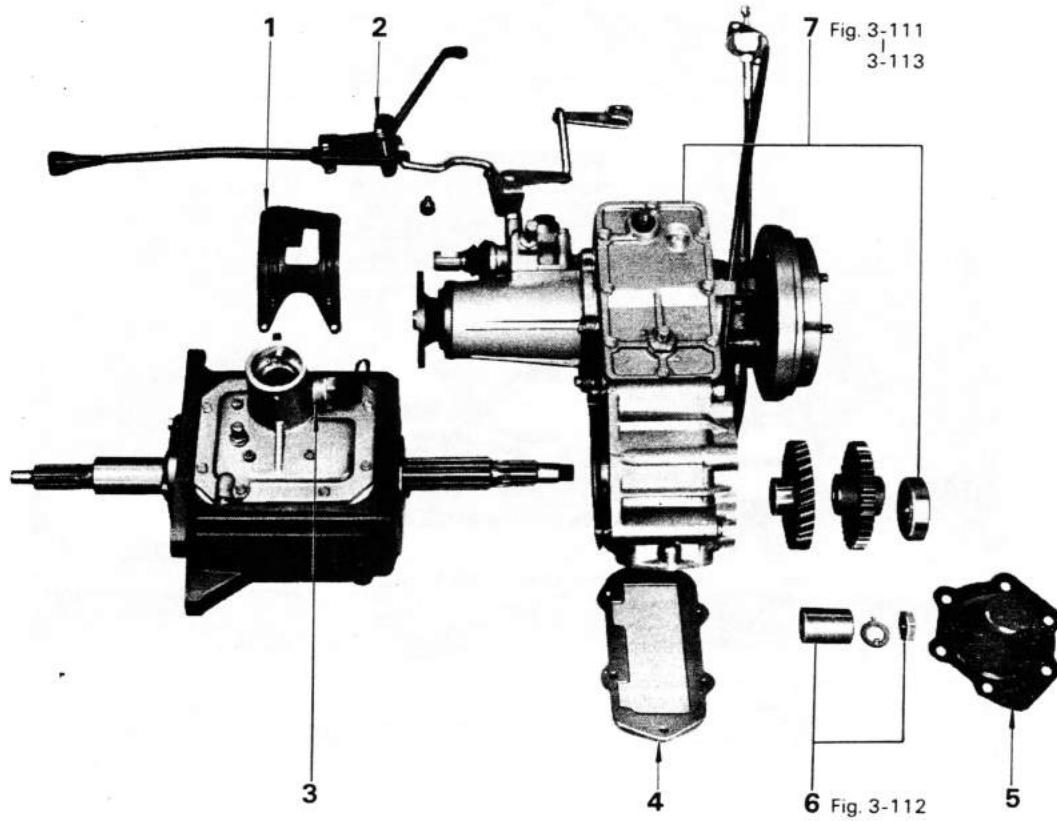

1. Shift Lever Guide
2. Lever & Rod
3. Back-up Light Switch
4. Power Take Off or Cover
5. No.2 Case Cover
6. Spacer, Washer & Nut
7. Transfer, Gear & Bearing

Fig. 3-111

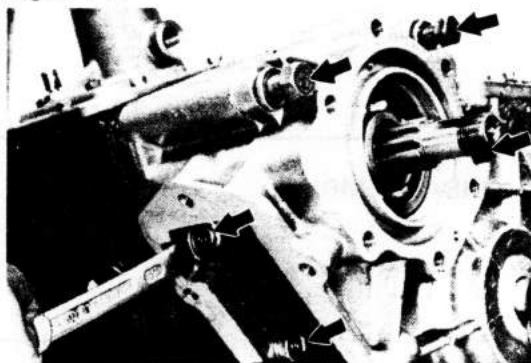

Remove the five bolts.

Fig. 3-112

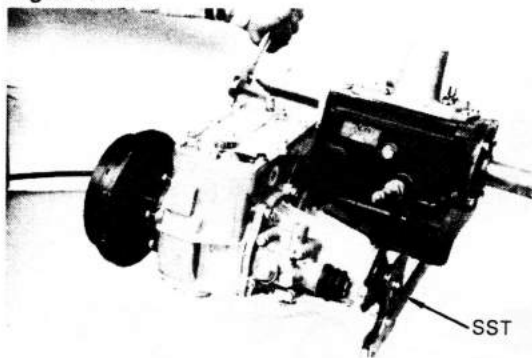

Loosen the staked parts of the nuts.  
Hold the output shaft with SST.  
SST [09330-00020]

— Note —  
Perform the work at front drive condition.

Fig. 3-113

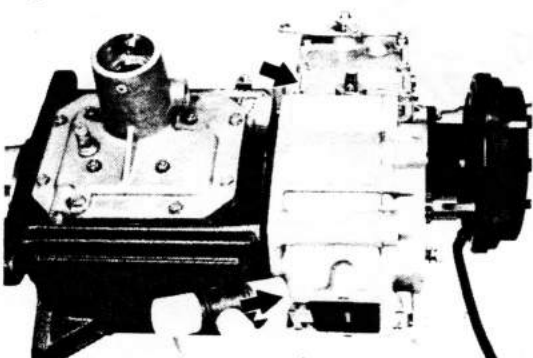

Tap out the transfer assembly.

**DISASSEMBLY**

1. Disassemble the parts in the numerical order shown in the figure.

Fig. 3-114

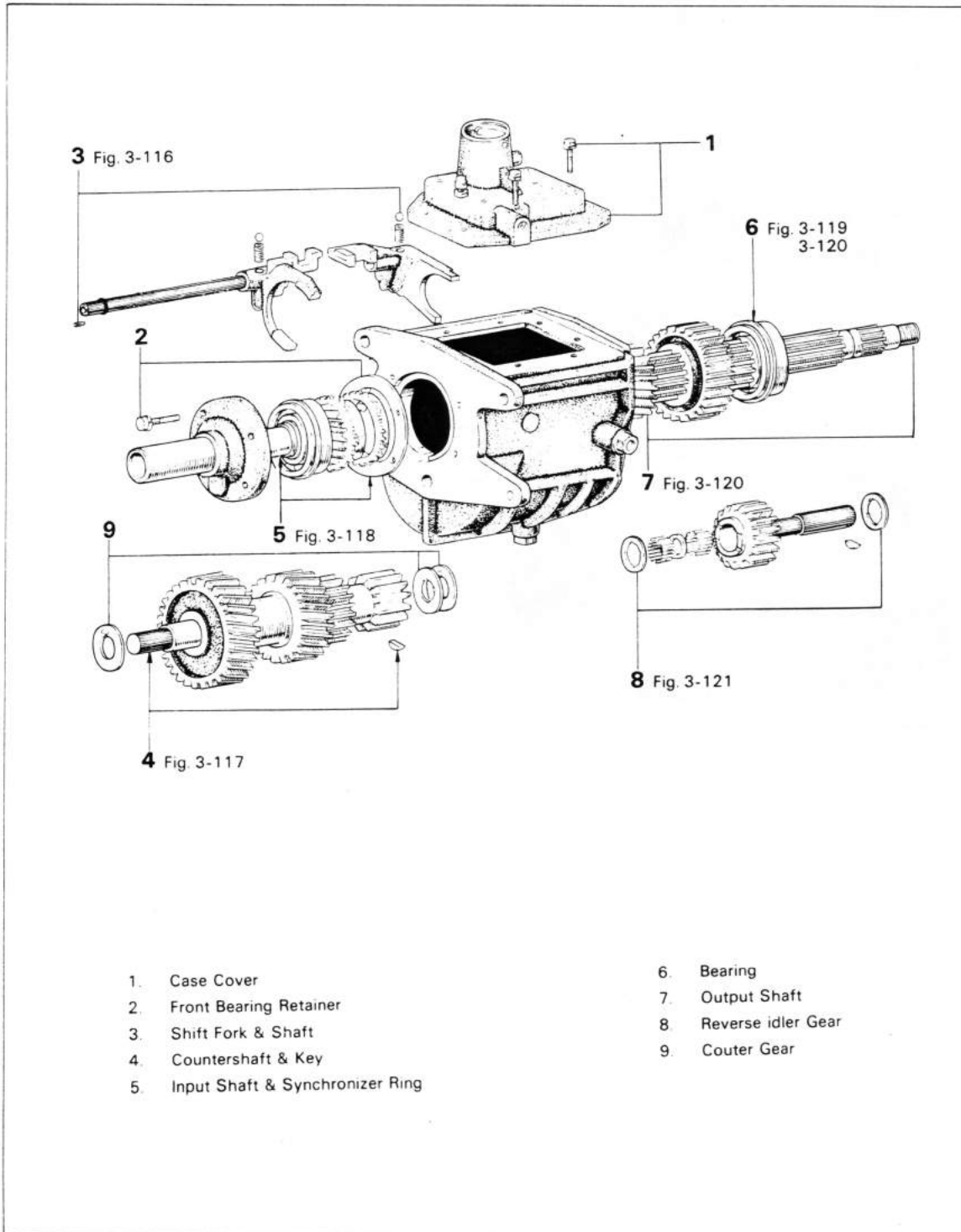

2. Disassemble the parts in the numerical order shown in the figure.

Fig. 3-115

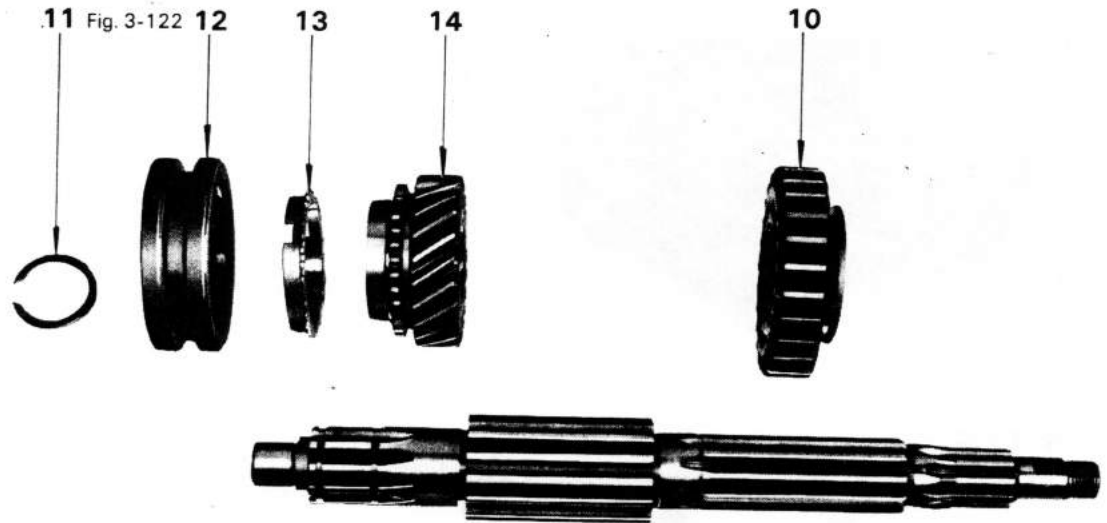

- |                         |                       |
|-------------------------|-----------------------|
| 10. 1st & Reverse Gear  | 13. Synchronizer Ring |
| 11. Snap Ring           | 14. 2nd Gear          |
| 12. Clutch Hub & Sleeve |                       |

Fig. 3-116

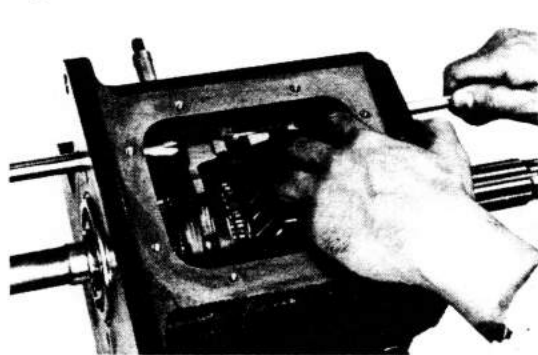

Drive out the shaft toward the front.

— Note —

Cover the locking ball hole with your finger so as to prevent the locking ball from jumping out.

Fig. 3-117

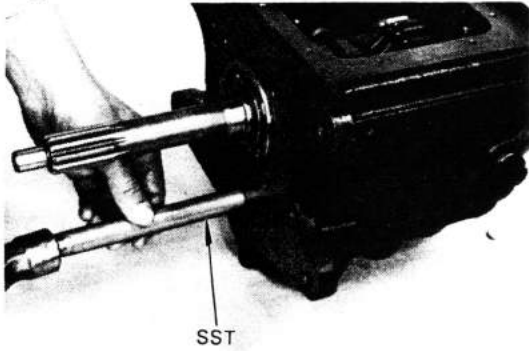

Drive out the shaft toward the rear with SST.  
SST [09311-60010]

Fig. 3-118

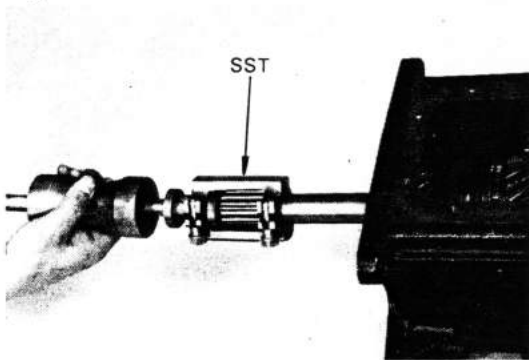

Remove the input shaft with SST.  
SST [09910-00014]

Fig. 3-119

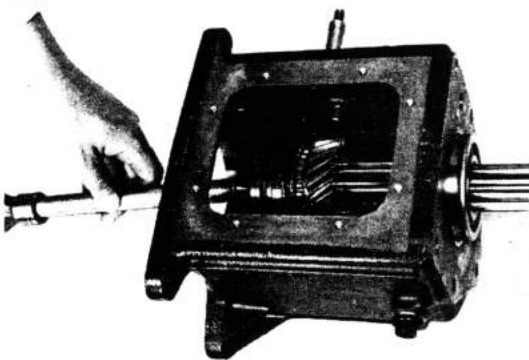

Using a brass bar, hammer the output shaft  
until the bearing is separated from the case.

Fig. 3-120

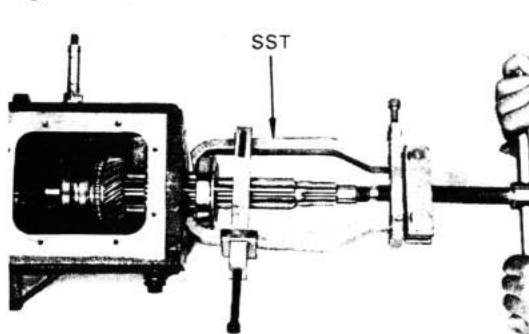

Remove the bearing with SST.  
SST [09950-20014]

Fig. 3-121

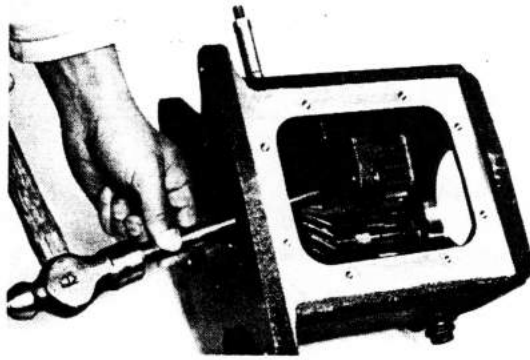

Using a drift pin, drive out the shaft.

Fig. 3-122

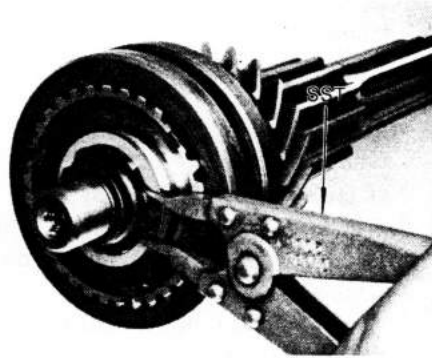

Remove the snap ring with SST. SST [09905-00012]

Fig. 3-123

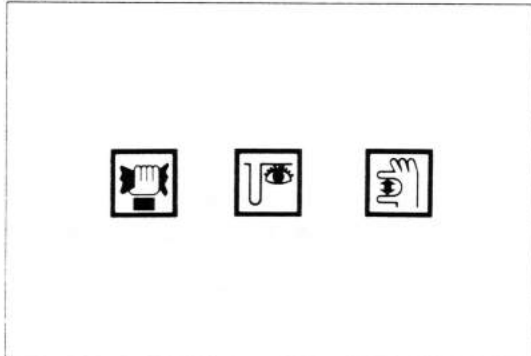

**INSPECTION**

After washing all disassembled parts, inspect them as instructed below. Replace all parts that are found defective.

Fig. 3-124

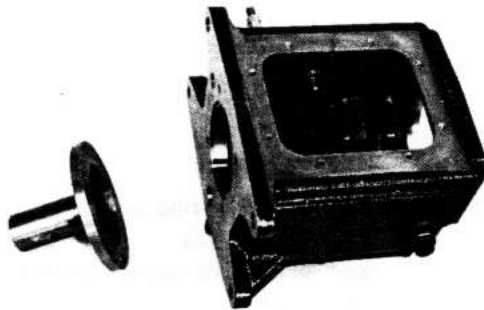

**Transmission Case & Front Bearing Retainer**

Inspect for wear or damage.

Fig. 3-125

**Output Shaft**

Inspect the shaft for wear or damage at the surfaces where the gears and bearing are installed.

Fig. 3-126

**1st Gear, 2nd Gear & Bearing**

1. Inspect the gears for wear or damage at the teeth, thrust faces, inside diameter surfaces, and coned parts.
2. Inspect the output shaft rear bearing for wear or damage.

Fig. 3-127

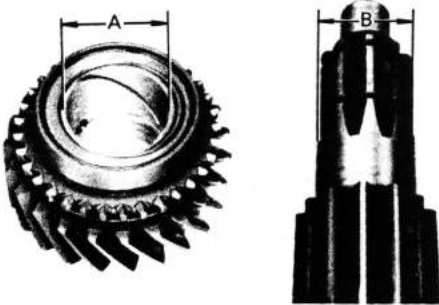

3. Measure the oil clearance.

**2nd gear bushing oil clearance (A - B):**

Limit 0.09 mm  
(0.0035 in.)

Fig. 3-128

**Synchronizer Ring**

1. Fit the synchronizer ring on the gear and measure the clearance.

**2nd & 3rd gear synchronizer ring clearance:**

Limit 0.8 mm  
(0.031 in.)

Fig. 3-129

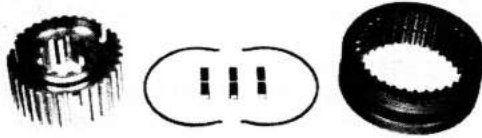

### Clutch Hub Sleeve, Clutch Hub, Shifting Key & Shifting Key Spring

1. Disassemble the clutch hub and sleeve.
2. Inspect the splines of hub and hub sleeve for wear or damage.
3. Inspect the humped part at center of key for wear or damage.
4. Inspect the key springs for weakening or damage.

Fig. 3-130

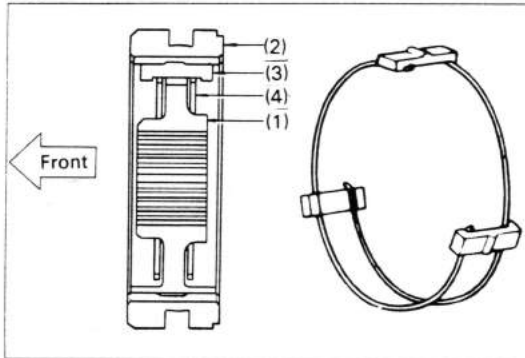

5. Assemble the hub sleeve (2), three shifting keys (3) and two key springs (4) to the clutch hub (1).

#### — Note —

1. Hub and hub sleeve are parts having directionality.
2. Install the key springs positioned so that their end gaps will not be in line.
3. Check the hub and hub sleeve to see that they slide smoothly together.

Fig. 3-131

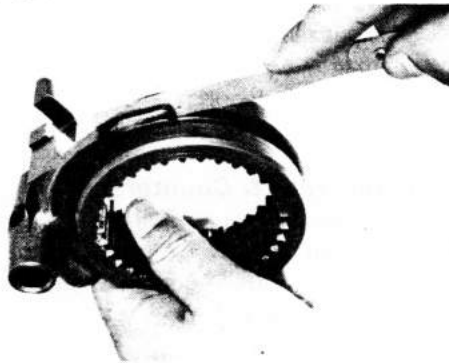

### Shift Fork

Check the clearance between the hub sleeve groove and the shift fork.

#### Clearance:

Limit 0.8 mm  
(0.031 in.)

Fig. 3-132

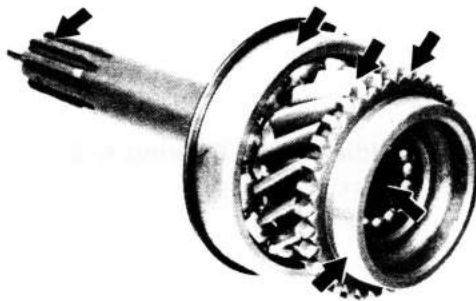

### Input Shaft

1. Inspect the gear teeth, splines, coned surfaces, and bearings for wear or damage.

Fig. 3-133

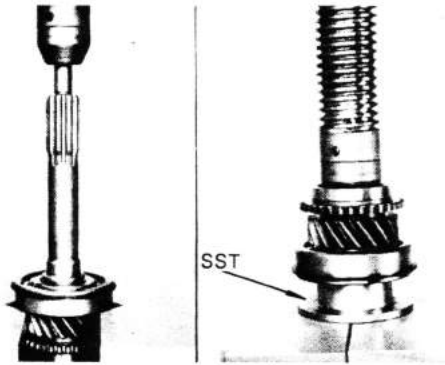

2. Replace the input shaft bearing.
  - (1) Remove the snap ring with SST. SST [09905-000012]
  - (2) Remove the bearing with a press.
  - (3) Using a press and SST, install the bearing. SST [09316-60010]

Fig. 3-134

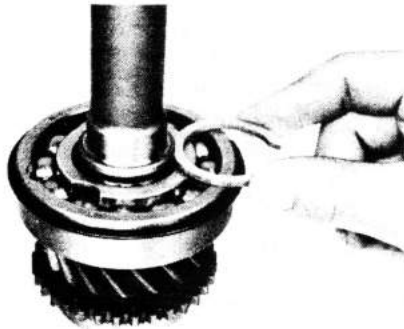

- (4) Select a snap ring of the thickness that will allow minimum axial play, and install it on the shaft.

Snap ring thickness

Part No.	Thickness mm (in.)
90520-33010	2.43-2.57 (0.0957-0.1012)
90520-33011	2.30-2.42 (0.0906-0.0953)

Fig. 3-135

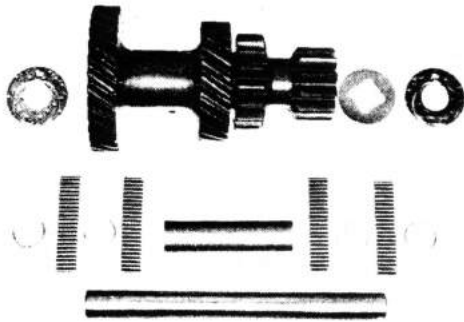

**Counter Gear & Countershaft**

1. Inspect the counter gear teeth for wear or damage.
2. Inspect the bearings and countershaft for wear or damage.
3. Inspect the thrust washers for wear or damage.

Fig. 3-136

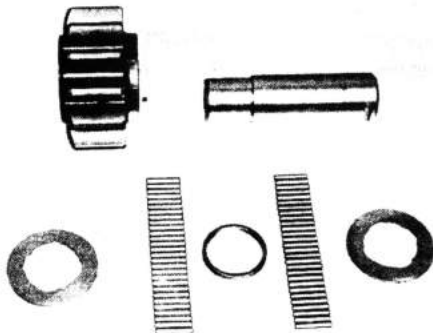

**Reverse Idler Gear, Bearing & Shaft**

- Inspect the gear, bearings, and shaft for wear or damage.

**ASSEMBLY**

1. Assemble the parts in the numerical order shown in the figure.

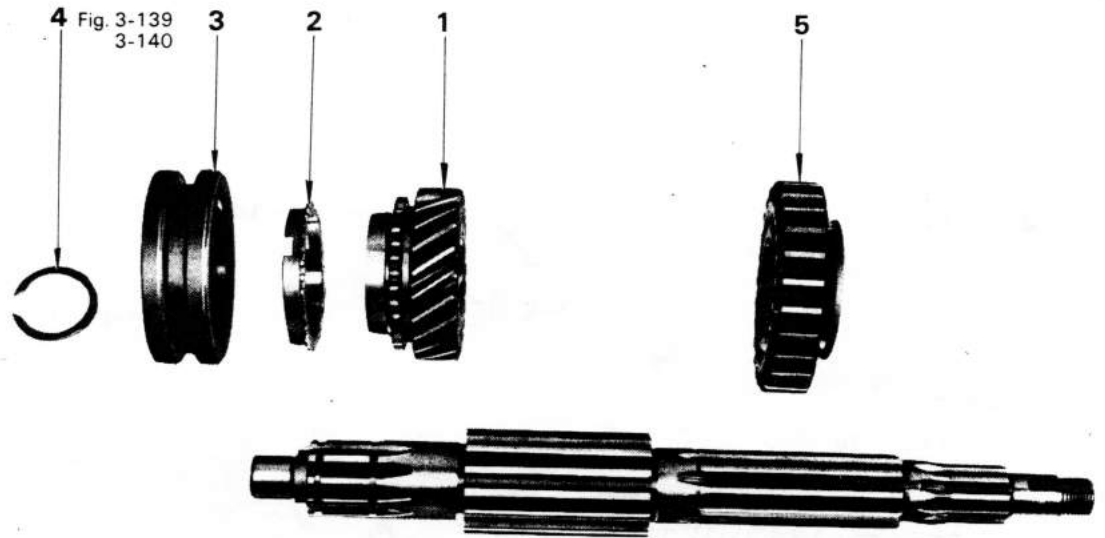
**Fig. 3-137**

1. 2nd Gear
2. Synchronizer Ring
3. Clutch Hub & Sleeve

4. Snap Ring
5. 1st & Reverse Gear

2. Assemble the parts in the numerical order shown in the figure.

Fig. 3-138

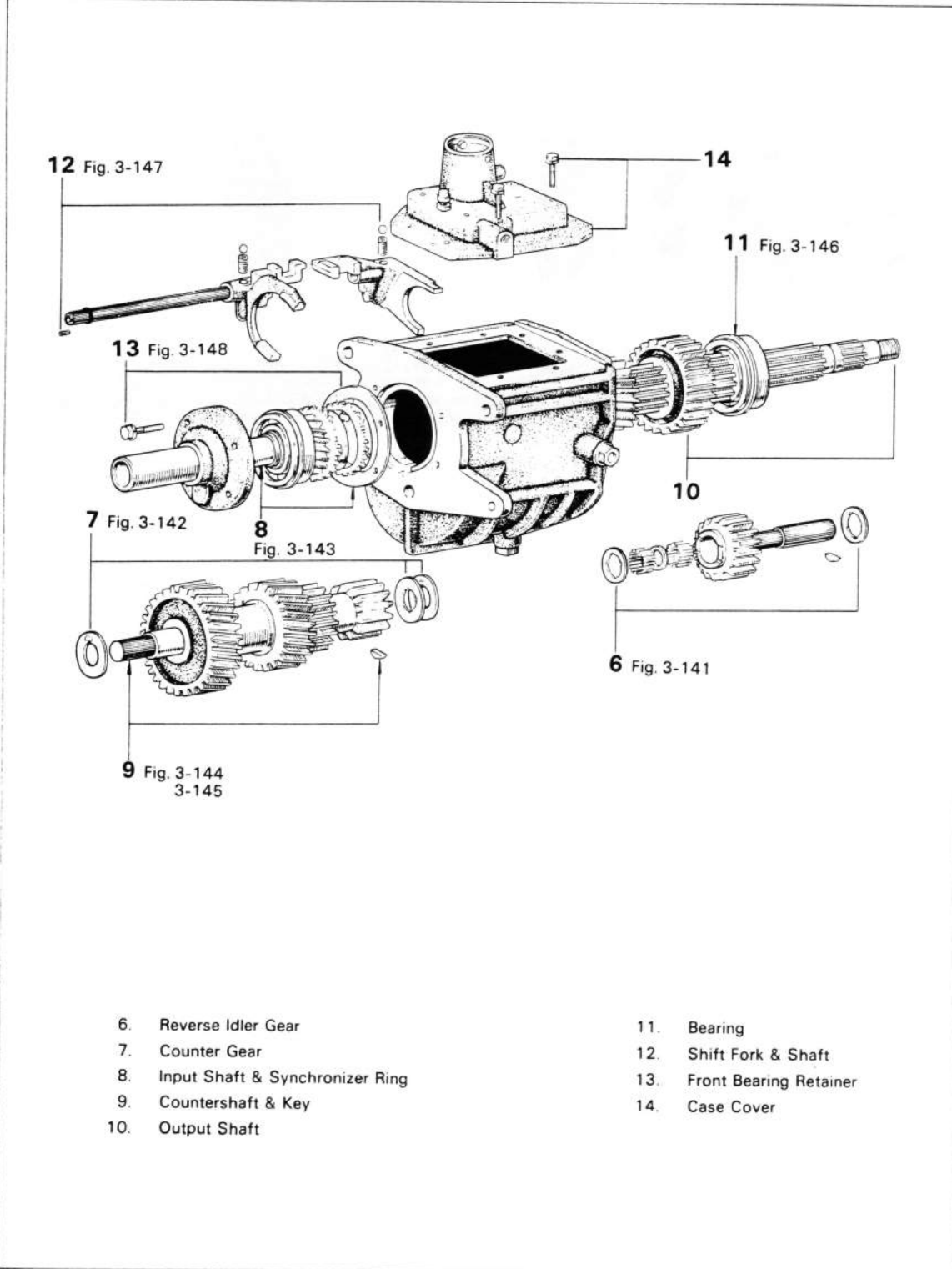

- |                                    |                            |
|------------------------------------|----------------------------|
| 6. Reverse Idler Gear              | 11. Bearing                |
| 7. Counter Gear                    | 12. Shift Fork & Shaft     |
| 8. Input Shaft & Synchronizer Ring | 13. Front Bearing Retainer |
| 9. Countershaft & Key              | 14. Case Cover             |
| 10. Output Shaft                   |                            |

Fig. 3-139

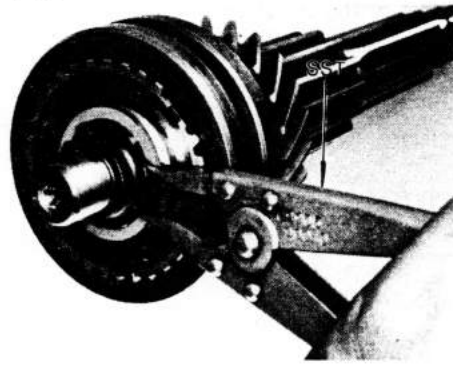

Install the snap ring with SST.  
SST [09905-00012]

Fig. 3-140

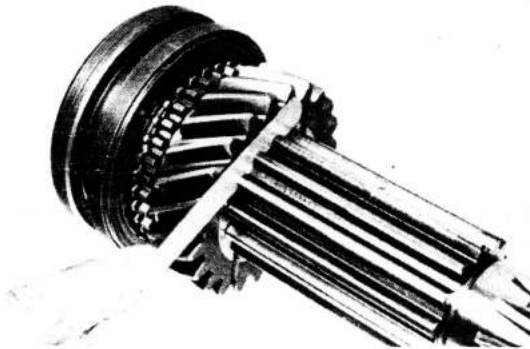

Measure the 2nd gear thrust clearance.

**Thrust clearance:**

**STD** 0.10–0.40 mm  
(0.0039–0.0157 in.)

**Limit** 0.4 mm  
(0.016 in.)

Snap ring thickness

Part No.	Thickness mm (in.)
90520-33132	2.35–2.40 (0.0925–0.0945)
90520-33172	2.25–2.30 (0.0886–0.0906)

Fig. 3-141

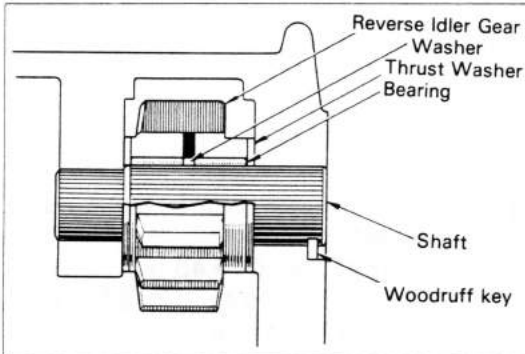

Install as illustrated at left.

**– Note –**

**Coat MP grease on the bearing, washer, and spacer before installing.**

Fig. 3-142

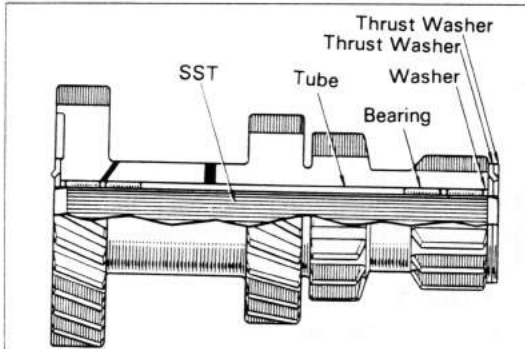

Assemble the counter gear assembly as illustrated at left, and install in the case with SST.

SST [09311-60010]

**– Note –**

**Coat MP grease on the bearing, washer, and spacer before installing.**

Fig. 3-143

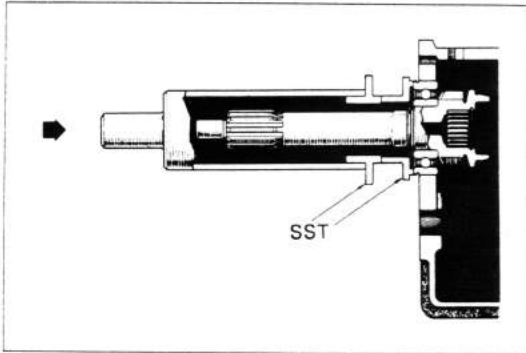

Drive in the input shaft with SST.  
SST [09316-60010]

Fig. 3-144

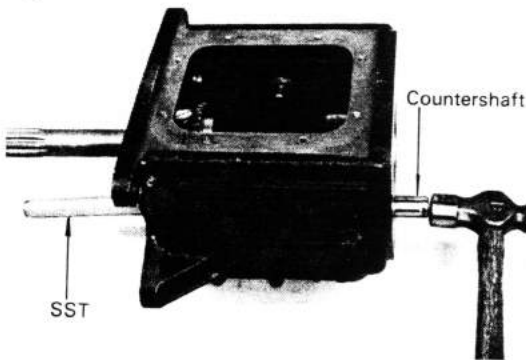

Drive in the countershaft and key.

Fig. 3-145

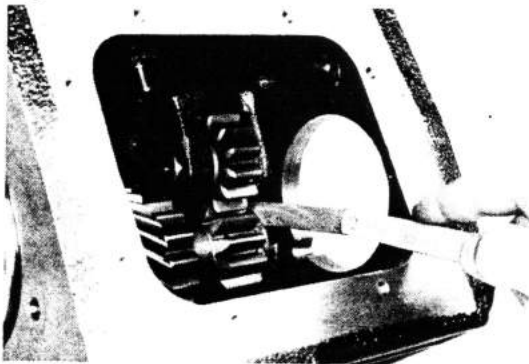

Measure the counter gear thrust clearance.

**Thrust clearance:**

**STD** 0.10–0.40 mm  
(0.0039–0.0157 in.)

**Limit** 0.4 mm  
(0.016 in.)

**Thrust washer thickness**

Part No.	Thickness mm (in.)
33441-61010	1.45–1.50 (0.0571–0.0591)
33442-61010	1.50–1.55 (0.0591–0.0610)
33443-61010	1.55–1.60 (0.0610–0.0630)

Fig. 3-146

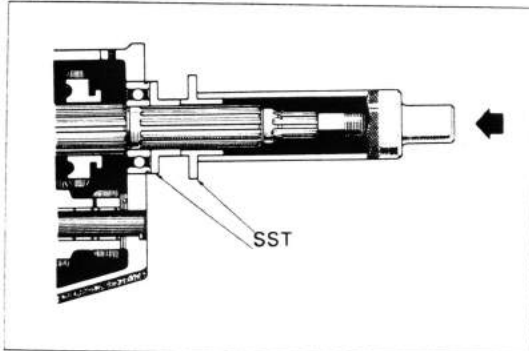

Drive in the bearing with SST.  
SST [09316-60010]

**– Note –**

Position the hub sleeve at 3rd gear, and insert the output shaft assembly into the case.

Fig. 3-147

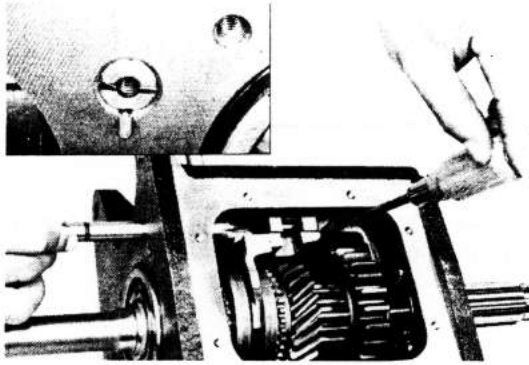

While holding down the locking ball, drive in the shaft, and then lock the shaft with a straight pin.

Fig. 3-148

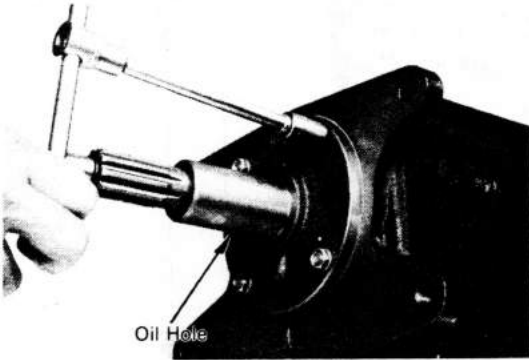

Install the retainer with its oil hole positioned downward.

**INSTALLATION**

Install the parts in the numerical order shown in the figure.

Fig. 3-149

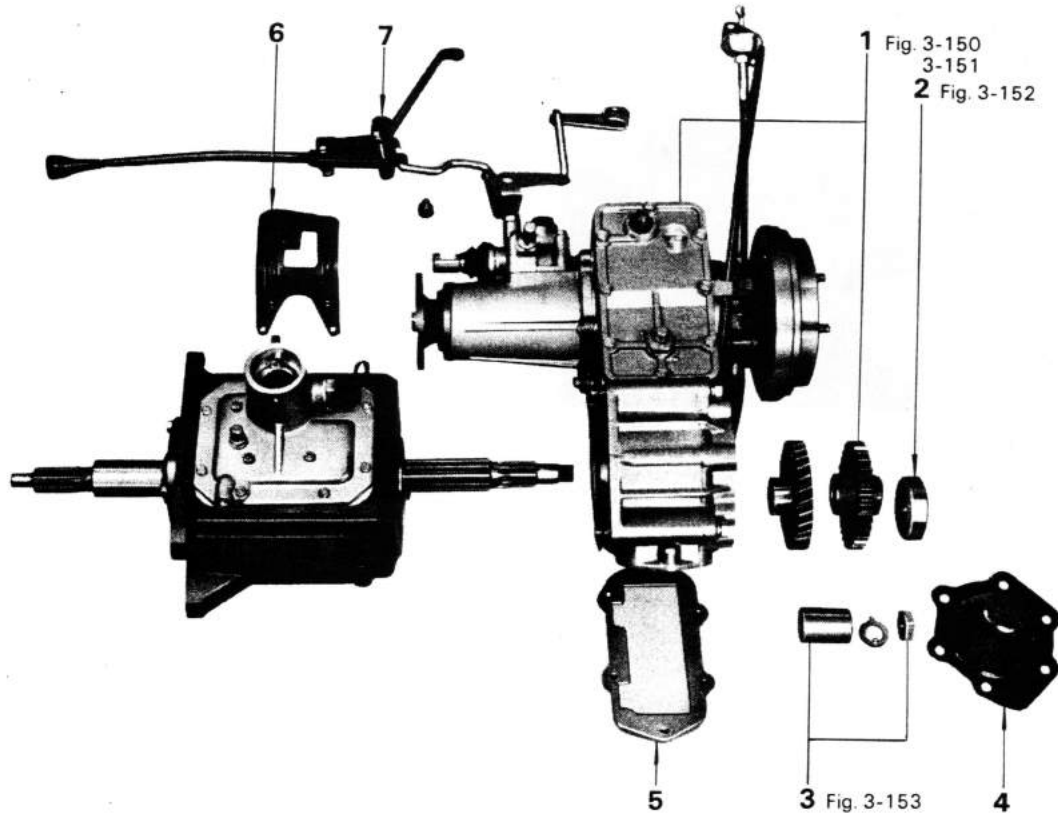

- |                         |                            |
|-------------------------|----------------------------|
| 1. Transfer & Gear      | 5. Power Take Off or Cover |
| 2. Bearing              | 6. Shift Lever Guide       |
| 3. Spacer, Washer & Nut | 7. Lever & Rod             |
| 4. No.2 Case Cover      |                            |

Fig. 3-150

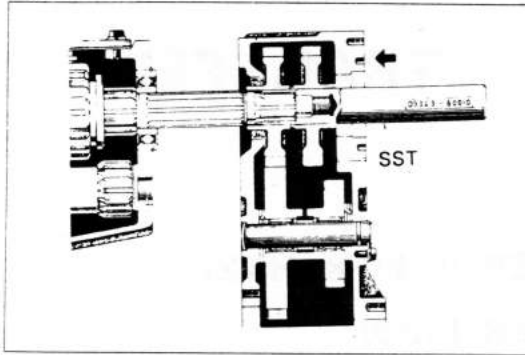

Mount SST to the output shaft.  
While supporting the gears with one hand, install the transfer assembly together with the gears to the SST.  
Align the splines of the output shaft and gears, and install the transfer to the transmission.  
SST [09323-60010]

— Note —

**Make sure that the gears are positioned in correct direction.**

Remove the SST from the output shaft.

Fig. 3-151

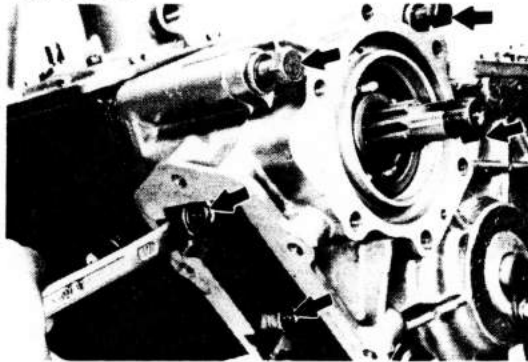

Tighten the five bolts at the specified torque.

**Tightening torque:**

**5.0 – 8.0 kg-m  
(37 – 57 ft-lb)**

Fig. 3-152

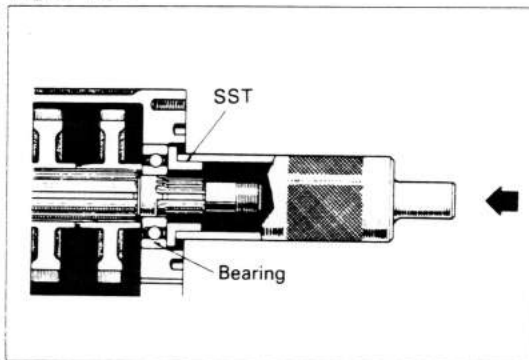

Drive in the bearing with SST.  
SST [09316-60010]

Fig. 3-153

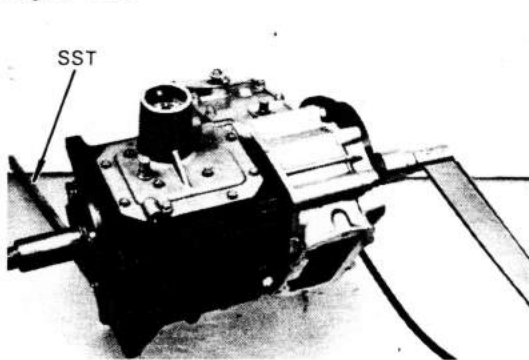

Keep the transfer output shaft from turning and tighten the nut with SST.  
SST [09330-00020]

**Tightening torque:**

**11.0 – 14.0 kg-m  
(80 – 101 ft-lb)**

Secure the nut with lock washer.

— Note —

**Perform the work with transmission in front drive.**