

# STEERING

	Page
PRECAUTIONS .....	SR-2
TROUBLESHOOTING .....	SR-2
ON-VEHICLE INSPECTION .....	SR-3
STEERING COLUMN ASSEMBLY WITH TILT	
STEERING .....	SR-4
STEERING GEAR HOUSING .....	SR-14
POWER STEERING .....	SR-25
On-Vehicle Inspection .....	SR-25
Bleeding of Power Steering System .....	SR-27
Oil Pressure Check .....	SR-27
Power Steering Pump .....	SR-29
Gear Housing .....	SR-38
STEERING BEVEL GEAR HOUSING .....	SR-58

## PRECAUTIONS

Care must be taken to replace each part properly because it could affect the performance of the steering system and result in a driving hazard.

## TROUBLESHOOTING

Problem	Possible cause	Remedy	Page
Hard steering	Tires improperly inflated	Inflate tires to proper pressure	FA-3, 30
	Wheel alignment incorrect	Check front wheel alignment	FA-3, 30
	Upper or lower arm ball joints worn	Replace ball joints	FA-16, 99
	Steering gear out of adjustment or broken	Adjust or repair steering gear	SR-14, 38, 58
	Power steering belt loose	Adjust belt	SR-25
	Fluid level in reservoir low	Add power steering fluid	SR-25
	Insufficient lubricant	Lubricate suspension and steering linkage	
	Power steering unit faulty	Replace power steering unit	SR-29
Poor return	Tires improperly inflated	Inflate tires to proper pressure	FA-3, 30
	Insufficient lubricant	Lubricate suspension and steering linkage	
	Wheel alignment incorrect	Check front wheel alignment	FA-3, 30
	Steering gear out of adjustment or broken	Adjust or repair steering gear	SR-14, 38, 58
Excessive play	Steering gear housing loose	Tighten gear housing mounting bolts	SR-24, 56
	Upper or lower arm ball joints worn	Replace ball joints	FA-16, 99
	Steering gear out of adjustment or broken	Adjust or repair steering gear	SR-14, 38, 58
Power steering noisy	Fluid level in reservoir low	Add power steering fluid	SR-25
	Power steering belt loose	Adjust belt	SR-25
	Air in power steering system	Bleed air	SR-27
	Fluid foamy or emulsified	Bleed air	SR-27
	PS pump faulty	Repair or replace PS pump	SR-29
	Power steering gear housing faulty	Replace gear housing	SR-38

## ON-VEHICLE INSPECTION

### 1. CHECK THAT STEERING WHEEL FREEPLAY IS CORRECT

With the vehicle stopped and wheels in straight ahead position, rock the steering wheel gently back and forth with light finger pressure. Freeplay should not exceed the maximum limit.

**Maximum play: 30 mm (1.18 in.)**

If incorrect, repair.

### 2. CHECK STEERING LINKAGE AND GEAR HOUSING

- (a) Check the steering linkage for looseness or damage. Also check that:
  - Tie rod ends do not have excessive play.
  - Boots are not damaged.
  - Boot clamps are not loose.
- (b) Check gear housing for grease leakage or oozing.

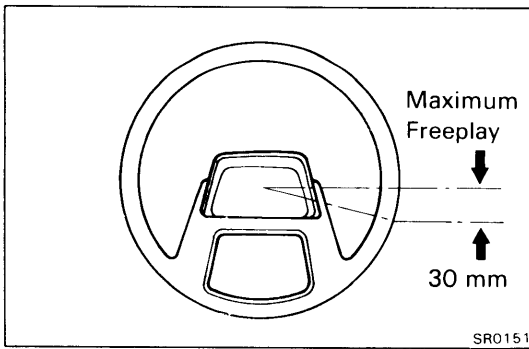

# STEERING COLUMN ASSEMBLY WITH TILT STEERING

## REMOVAL OF STEERING COLUMN ASSEMBLY

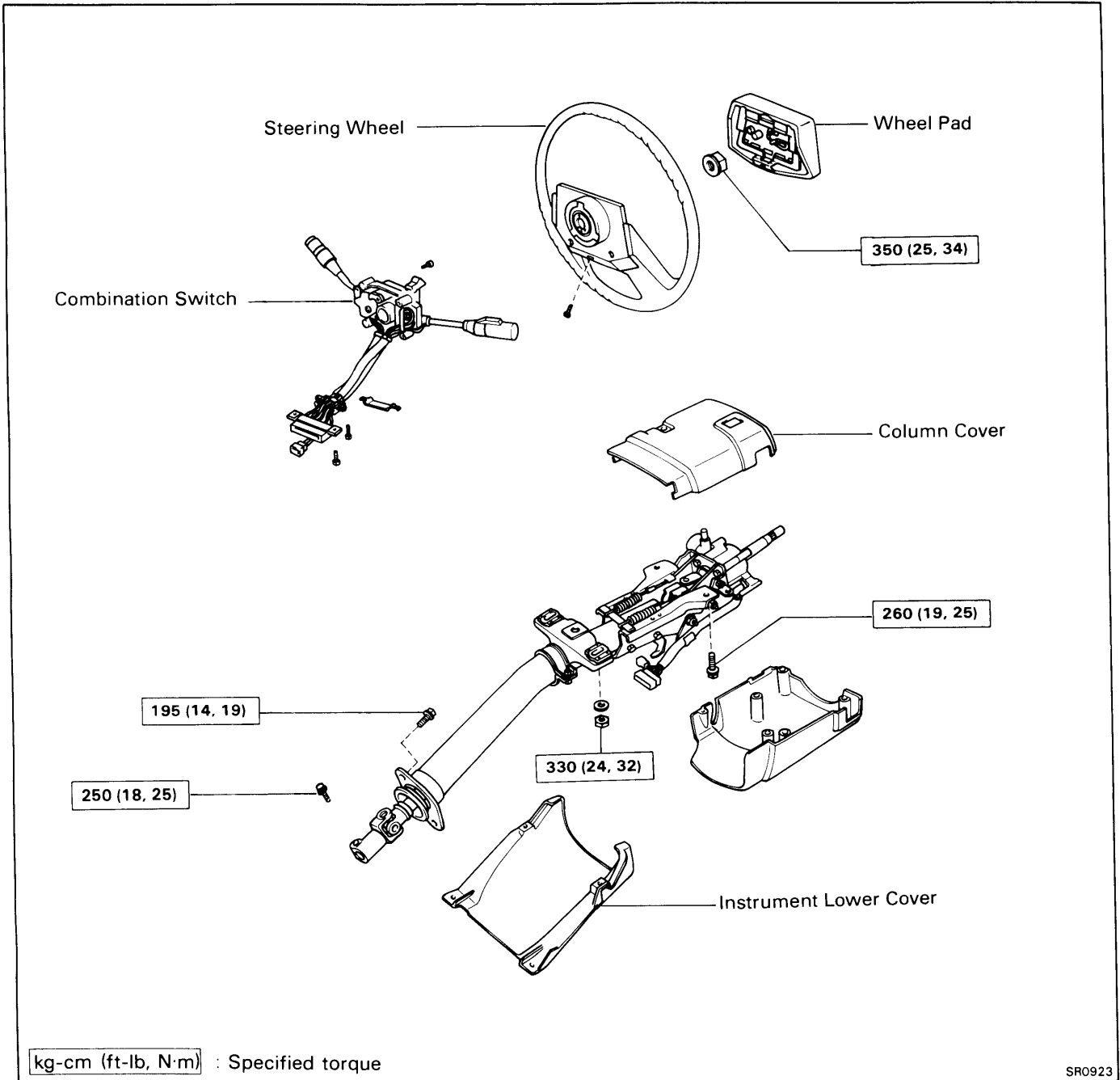

cardiagn.com

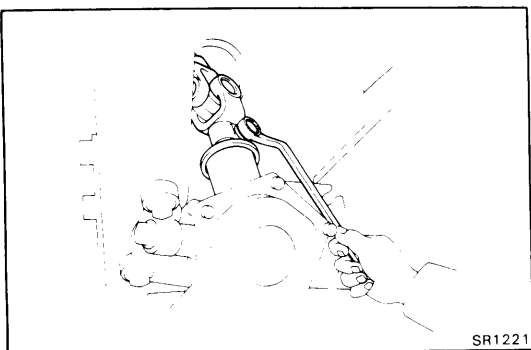

1. **DISCONNECT NEGATIVE CABLE FROM BATTERY**
2. **REMOVE UNIVERSAL JOINT BOLT**
  - (a) Place matchmarks on the intermediate shaft and bevel gear to ensure correct reassembly.
  - (b) Remove the universal joint bolt.

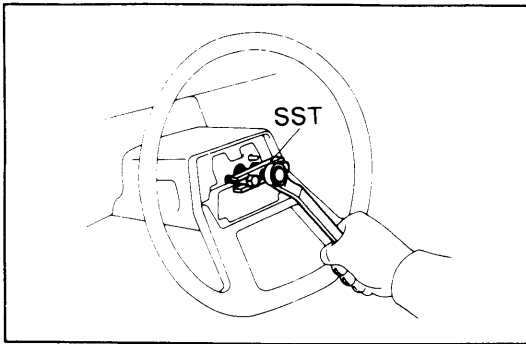

**3. REMOVE STEERING WHEEL**

- (a) Remove the steering wheel pad with the screw.
- (b) Disconnect the horn connector.
- (c) Remove the steering wheel nut.
- (d) Using SST, remove the steering wheel.

SST 09609-20011

**4. REMOVE INSTRUMENT LOWER COVER**

**5. REMOVE COLUMN COVERS AND COMBINATION SWITCH**

**6. REMOVE TWO COLUMN TUBE BOLTS**

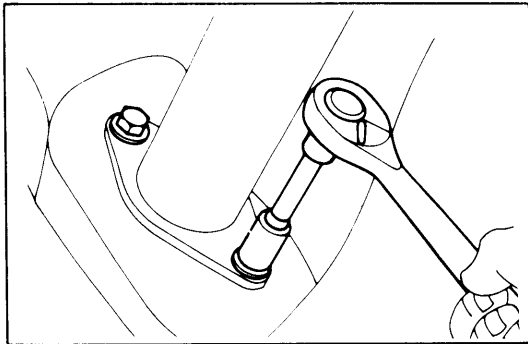

**7. REMOVE COLUMN BRACKET MOUNTING BOLTS AND COLUMN TUBE MOUNTING NUTS**

**8. PULL OUT COLUMN TUBE AND SHAFT**

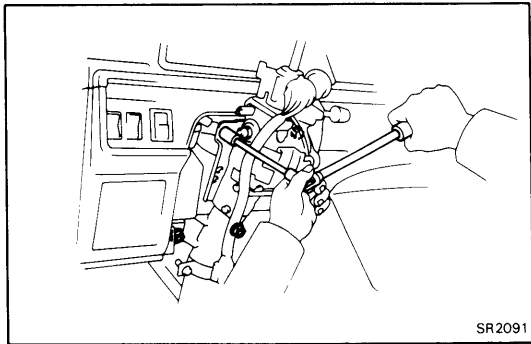

SR2091

COMPONENTS

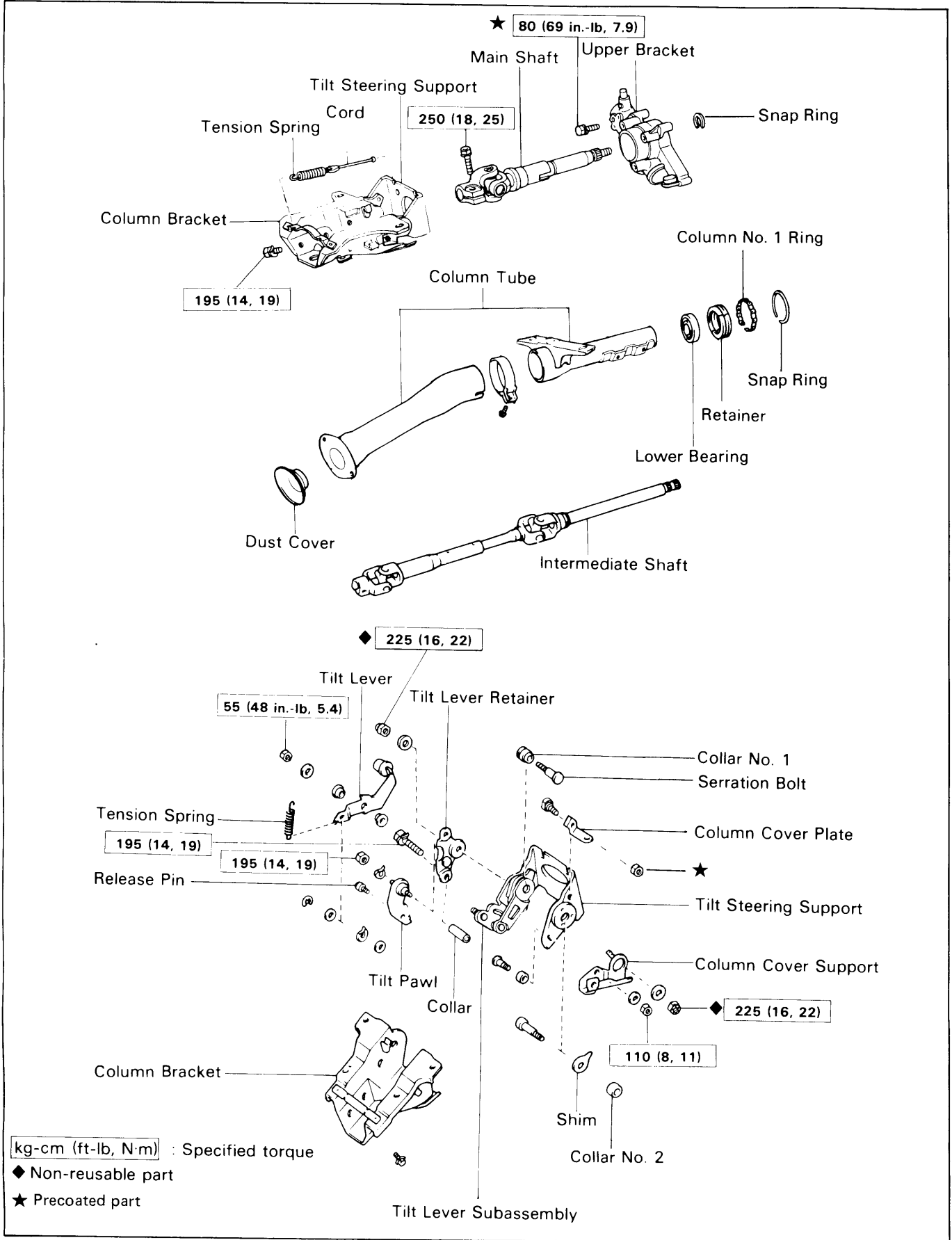

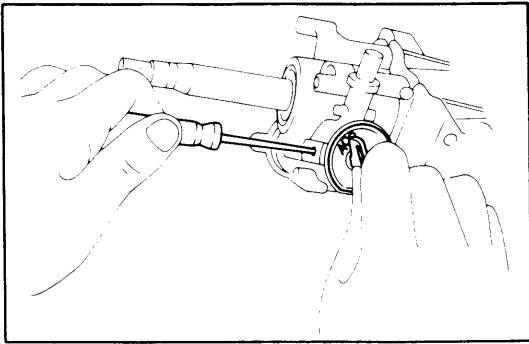

## DISASSEMBLY OF STEERING COLUMN ASSEMBLY AND TILT MECHANISM

(See page SR-6)

### 1. REMOVE IGNITION KEY CYLINDER

- (a) Place the ignition key at the ACC position.
- (b) Push down the stop key with a thin rod, and pull out the key cylinder.

### 2. REMOVE IGNITION SWITCH

### 3. REMOVE TENSION SPRINGS AND CORDS

- (a) Fully tilt the main shaft upward.
- (b) Release the cord from the hook.
- (c) Using a screwdriver, pry out the cord tip and remove the spring and cord.

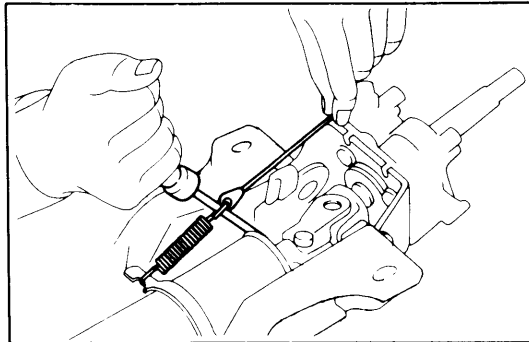

### 4. REMOVE COLUMN COVER PLATE

### 5. DISCONNECT INTERMEDIATE SHAFT AND MAIN SHAFT

- (a) Place matchmarks on the intermediate shaft and universal joint.
- (b) Remove the joint bolt.
- (c) Remove the four bracket bolts.
- (d) Remove the column tube with the intermediate shaft.

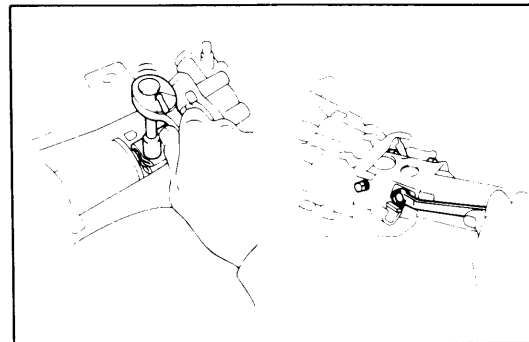

### 6. REMOVE UPPER BRACKET WITH MAIN SHAFT FROM COLUMN BRACKET

### 7. REMOVE MAIN SHAFT FROM UPPER BRACKET

- (a) Using a soft jaws vise and snap ring pliers, remove the snap ring.
- (b) Pull out the main shaft from the bracket.

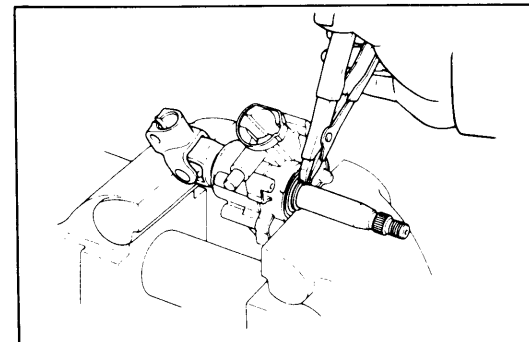

### 8. REMOVE TILT LEVER

- (a) Remove the tension spring.
- (b) Remove the E-ring and bushing.
- (c) Remove the nut, plate washer and nylon bushing.
- (d) Remove the lever, bushing, wave washer and nylon bushing.

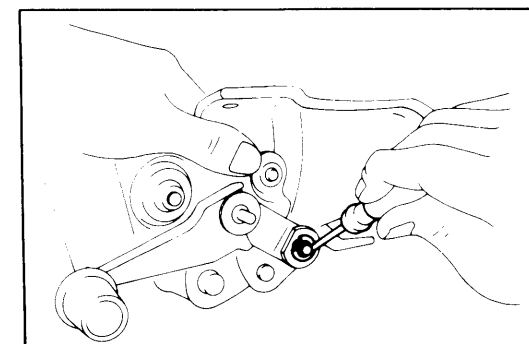

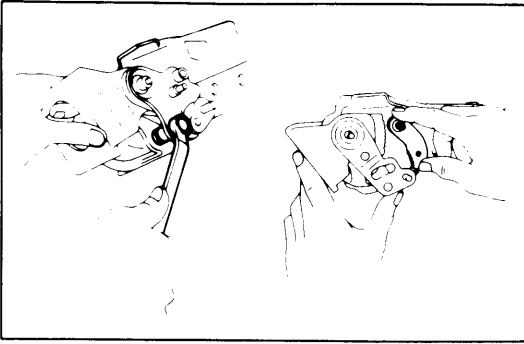
**9. REMOVE TILT LEVER RETAINER**

- (a) Remove the bolt, two nuts and two washers.
- (b) Remove the lever retainer and collar.

**10. REMOVE TILT PAWL**

Pull out the release pin and remove the tilt pawl.

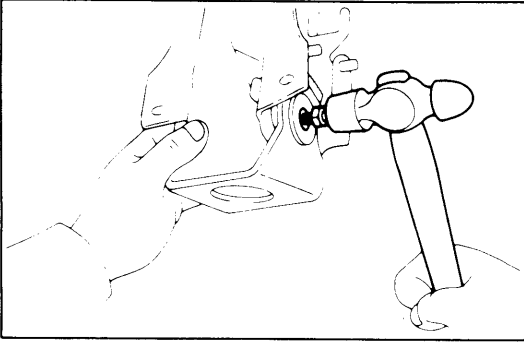
**11. REMOVE SERRATION BOLT**

Temporarily install another nut flat with the end of the bolt and tap it in with a hammer.

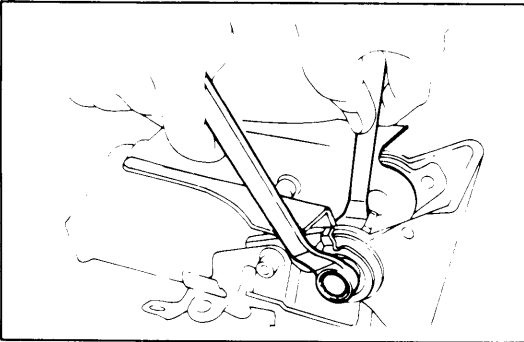
**12. REMOVE TILT LEVER SUBASSEMBLY****13. REMOVE COLUMN COVER SUPPORT**

Remove the following parts:

- (a) Nuts
- (b) Bolts
- (c) Collars
- (d) Washers

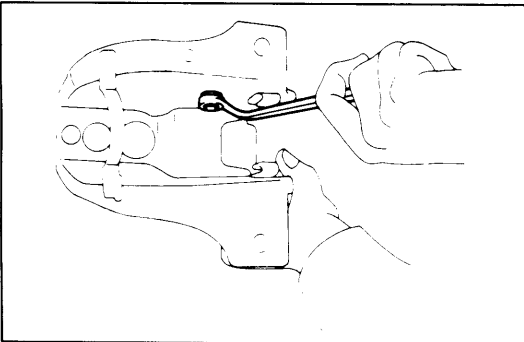
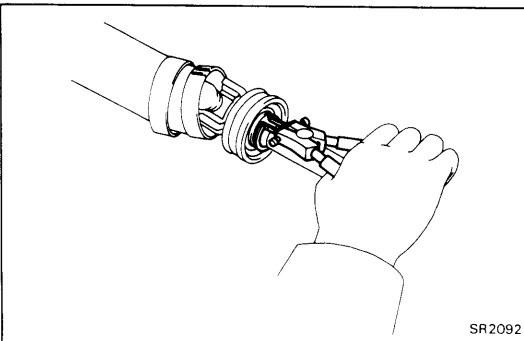
**14. REMOVE TILT STEERING SUPPORT****15. REMOVE PAWL SET BOLT****16. REMOVE INTERMEDIATE SHAFT**

- (a) Remove the clamp bolt and pull out the intermediate shaft from the upper tube.
- (b) Using snap ring pliers, remove the snap ring.
- (c) Remove the lower bearing from the shaft.
- (d) Pull out the shaft from the lower tube.

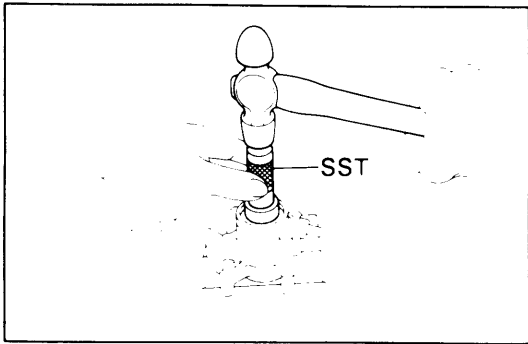

## INSPECTION AND REPAIR OF STEERING COLUMN ASSEMBLY

### 1. IF NECESSARY, REPLACE BEARING IN UPPER BRACKET

(a) Remove the bearing with a hammer and SST.  
SST 09620-30010 (09623-30010)

(b) Pack MP grease into a new bearing.

(c) Using SST and a hammer, drive the bearing into the bracket.

SST 09620-30010 (09631-00020, 09624-30010)

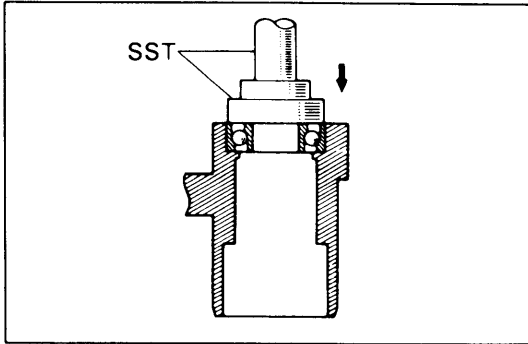

### 2. IF NECESSARY, REPLACE LOWER BEARING

(a) Using SST and a press, remove the lower bearing from the main shaft.

SST 09527-20011

(b) Pack MP grease into a new bearing.

(c) Using SST and a press, assemble the lower bearing and main shaft.

SST 09236-00101 (09237-00010)  
09612-22011

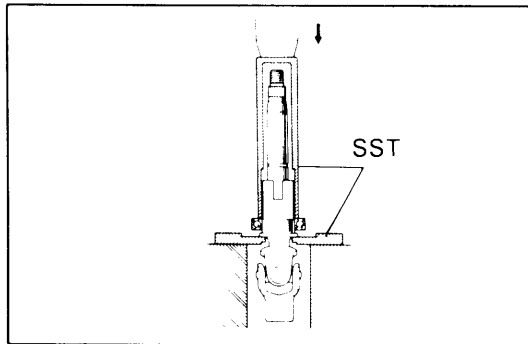
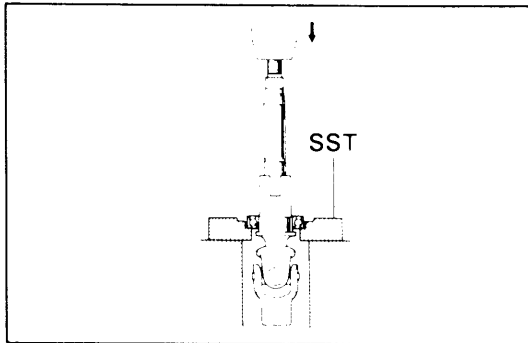

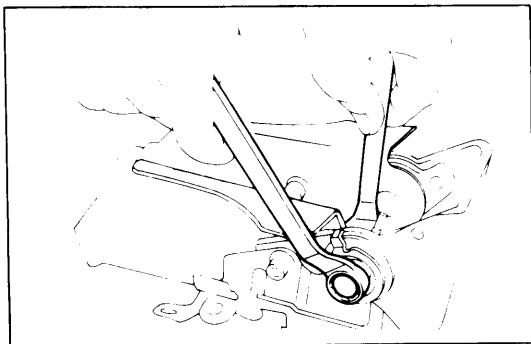
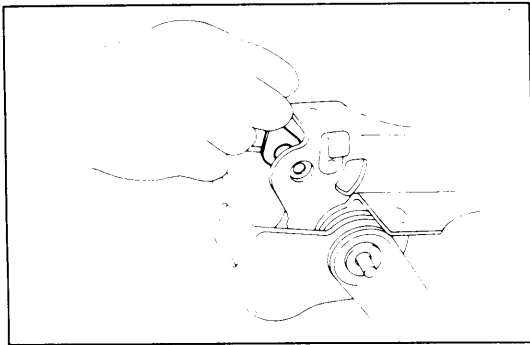
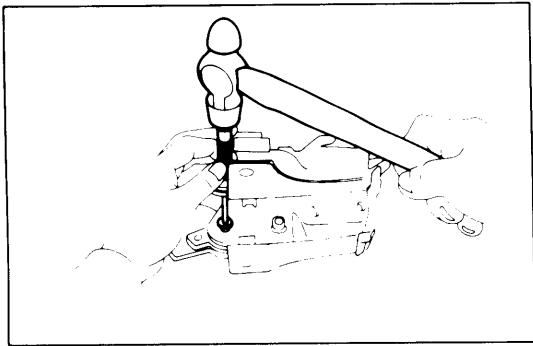
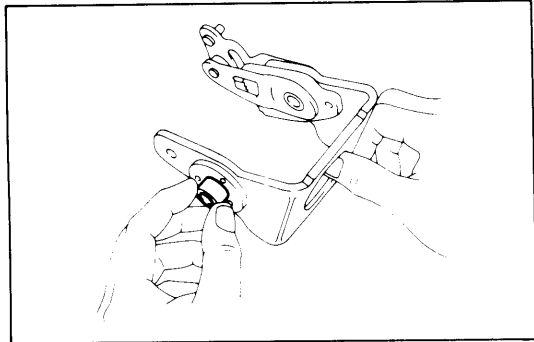
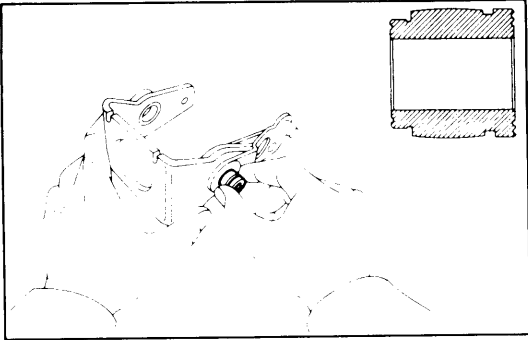

## ASSEMBLY OF STEERING COLUMN ASSEMBLY AND TILT MECHANISM

(See page SR-6)

1. APPLY MP GREASE TO ALL RUBBING PARTS
2. ASSEMBLE TILT LEVER SUBASSEMBLY AND COLLARS NO. 1 AND NO. 2

(a) Select a collar No. 1 which will eliminate all play.

Outer diameter		mm (in.)
17.989–17.996	(0.7082–0.7085)	
17.996–18.003	(0.7085–0.7088)	
18.003–18.010	(0.7088–0.7091)	
18.010–18.017	(0.7091–0.7093)	
18.017–18.024	(0.7093–0.7096)	

(b) Install the tilt lever subassembly and collar No. 1 to the support.

(c) Select a collar No. 2 which will eliminate all play.

Outer diameter		mm (in.)
17.982–18.000	(0.7080–0.7087)	
18.000–18.018	(0.7087–0.7094)	

(d) Install collar No. 2 to the support.

### 3. INSTALL PAWL SET BOLT

Install the pawl set bolt and torque the nut.

**Torque: 195 kg-cm (14 ft-lb, 19 N·m)**

### 4. INSTALL TILT STEERING SUPPORT TO COLUMN BRACKET

Install the tilt steering support to the column bracket and drive in the serration bolt.

### 5. INSTALL SHIM AND BOLT

(a) Select a shim which fits snugly when pressed in by hand.

Thickness		mm (in.)
0.2	(0.008)	1.4 (0.055)
0.5	(0.020)	1.8 (0.071)
0.8	(0.031)	

(b) Install the shim and bolt.

### 6. INSTALL COLUMN COVER SUPPORT

Install the following parts:

- (a) Column cover support
- (b) Bolt and collar
- (c) Washers and nuts

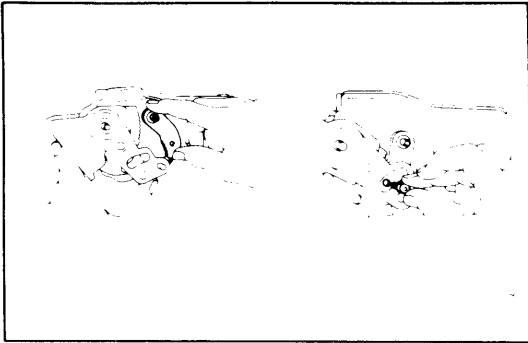

**7. INSTALL TILT PAWL**

Install the tilt pawl and the release pin.

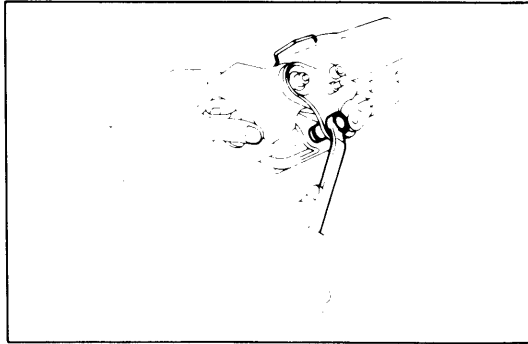

**8. INSTALL TILT LEVER RETAINER**

- (a) Install the collar and lever retainer.
- (b) Install the bolt, two nuts and washers.

**Torque: 195 kg-cm (14 ft-lb, 19 N·m)**

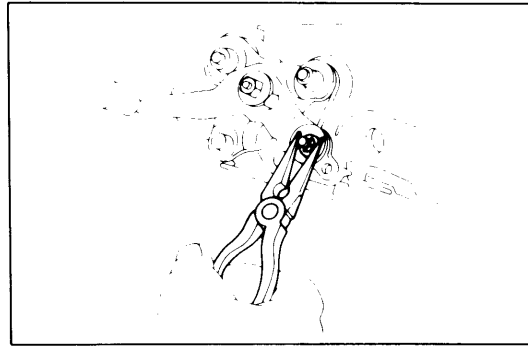

**9. INSTALL TILT LEVER**

- (a) Install the nylon bushing, wave washer, bushing and lever.
- (b) Install the nylon bushing, plate washer and nut.
- (c) Install the bushing and E-ring.
- (d) Install the tension spring.

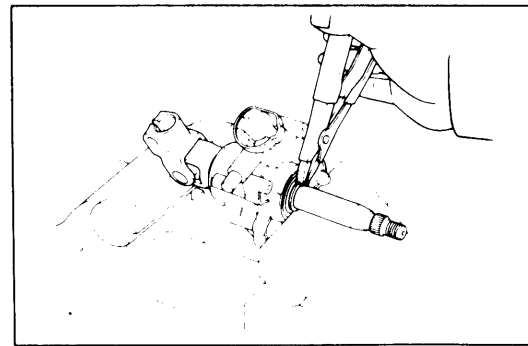

**10. INSTALL MAIN SHAFT TO UPPER BRACKET**

- (a) Insert the main shaft to the upper bracket.
- (b) Using a soft jaws vise and snap ring pliers, install the snap ring.

**11. INSTALL IGNITION SWITCH**

**12. INSTALL IGNITION KEY CYLINDER**

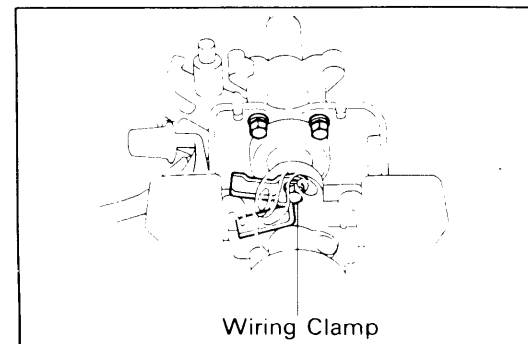

**13. INSTALL UPPER BRACKET WITH MAIN SHAFT TO COLUMN BRACKET**

- (a) Apply sealant to 1 or 2 threads of the bolt end.

**Sealant: Part No. 08833-00070, THREE BOND 1324 or equivalent**

- (b) Install the two bolts; one with a wiring clamp.

**Torque: 80 kg-cm (69 in.-lb, 7.9 N·m)**

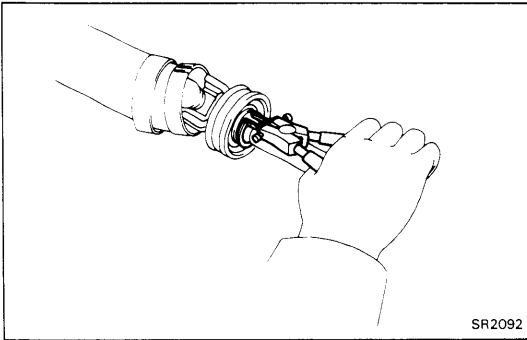
**14. INSTALL INTERMEDIATE SHAFT TO COLUMN TUBE**

- (a) Insert the intermediate shaft into the lower tube.
- (b) Install the lower bearing.
- (c) Using snap ring pliers, install the snap ring.
- (d) Install the upper tube and tighten the clamp bolt.

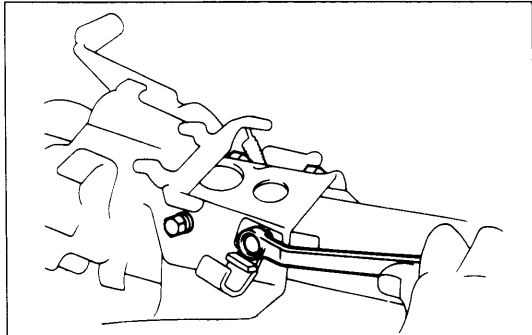
**15. INSTALL COLUMN TUBE TO COLUMN BRACKET**

Install the three bolts; one with a wiring clamp.

**Torque: 195 kg-cm (14 ft-lb, 19 N·m)**

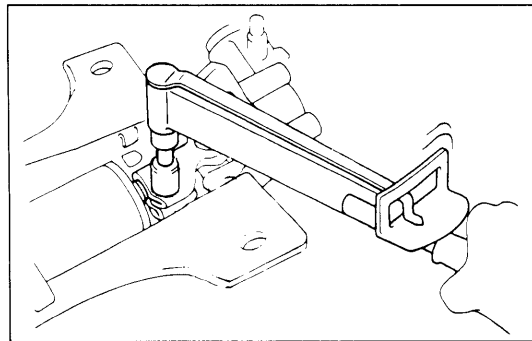
**16. CONNECT INTERMEDIATE SHAFT TO MAIN SHAFT**

Align the matchmarks on the universal joint and intermediate shaft and tighten the bolt.

**Torque: 250 kg-cm (18 ft-lb, 25 N·m)**

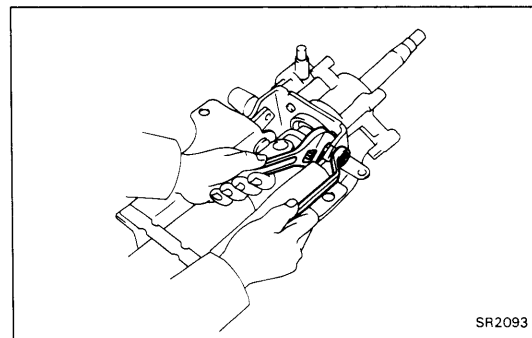
**17. INSTALL COLUMN COVER PLATE**

- (a) Apply sealant to 1 or 2 threads of the bolt end.

**Sealant: Part No. 08833-00070, THREE BOND 1324 or equivalent**

- (b) Install the column cover plate with the bolt and nut.

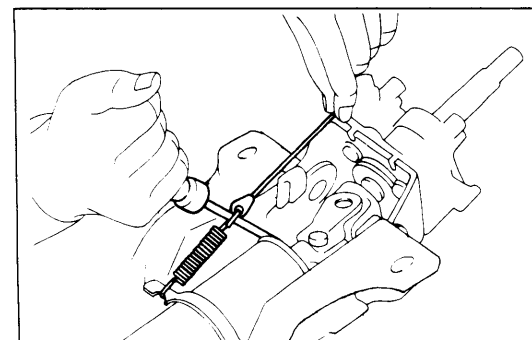
**18. INSTALL TENSION SPRINGS AND CORDS**

- (a) Connect the spring and cord, and hook the spring to the hanger.
- (b) Hook the cord end to the tilt steering support.
- (c) Hook the cord to the tilt steering support hook.

## INSTALLATION OF STEERING COLUMN ASSEMBLY

(See page SR-4)

1. PLACE COLUMN AND SHAFT IN INSTALLED POSITION

2. CONNECT UNIVERSAL JOINT

Line up the marks on the universal joint and bevel gear.

3. INSTALL COLUMN BRACKET MOUNTING BOLTS AND COLUMN TUBE MOUNTING NUTS BY HAND

4. INSTALL COLUMN TUBE BOLTS

Torque: 195 kg-cm (14 ft-lb, 19 N·m)

5. TORQUE COLUMN BRACKET MOUNTING BOLTS

Torque: 260 kg-cm (19 ft-lb, 25 N·m)

6. TORQUE COLUMN TUBE MOUNTING NUTS

Torque: 330 kg-cm (24 ft-lb, 32 N·m)

7. INSTALL COUPLING SET BOLT

Torque: 250 kg-cm (18 ft-lb, 25 N·m)

8. INSTALL COMBINATION SWITCH AND COLUMN COVERS

9. INSTALL INSTRUMENT LOWER COVER

10. INSTALL STEERING WHEEL

(a) Position the front wheels straight ahead and install the steering wheel in neutral position.

(b) Tighten the nut.

Torque: 350 kg-cm (25 ft-lb, 34 N·m)

(c) Install the steering wheel pad with the screw.

11. CONNECT NEGATIVE CABLE TO BATTERY

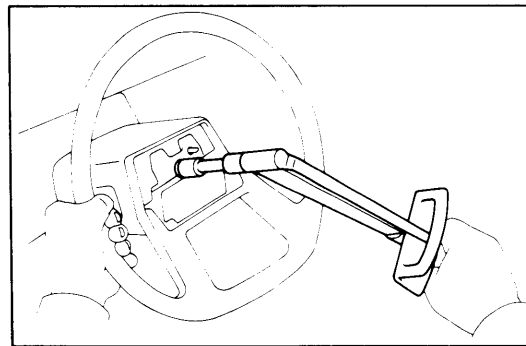
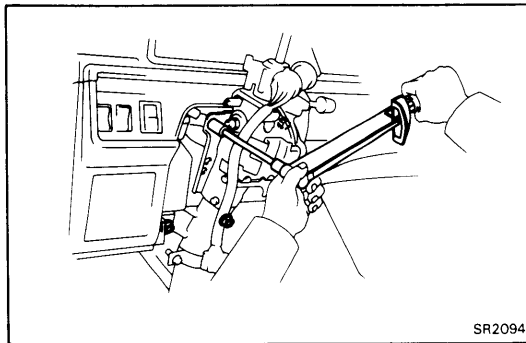
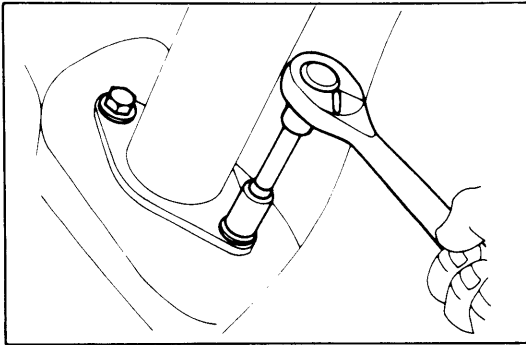
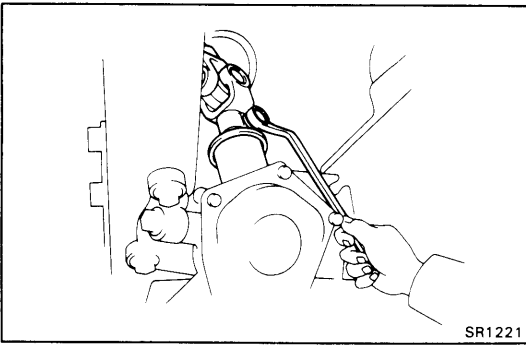

## STEERING GEAR HOUSING REMOVAL OF GEAR HOUSING

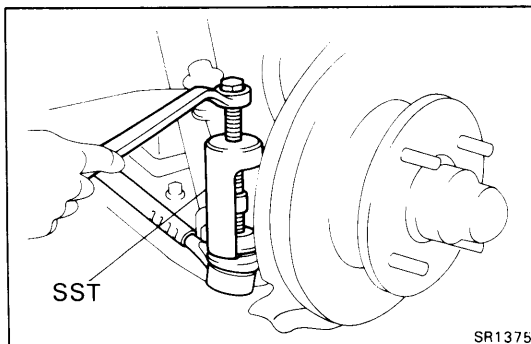
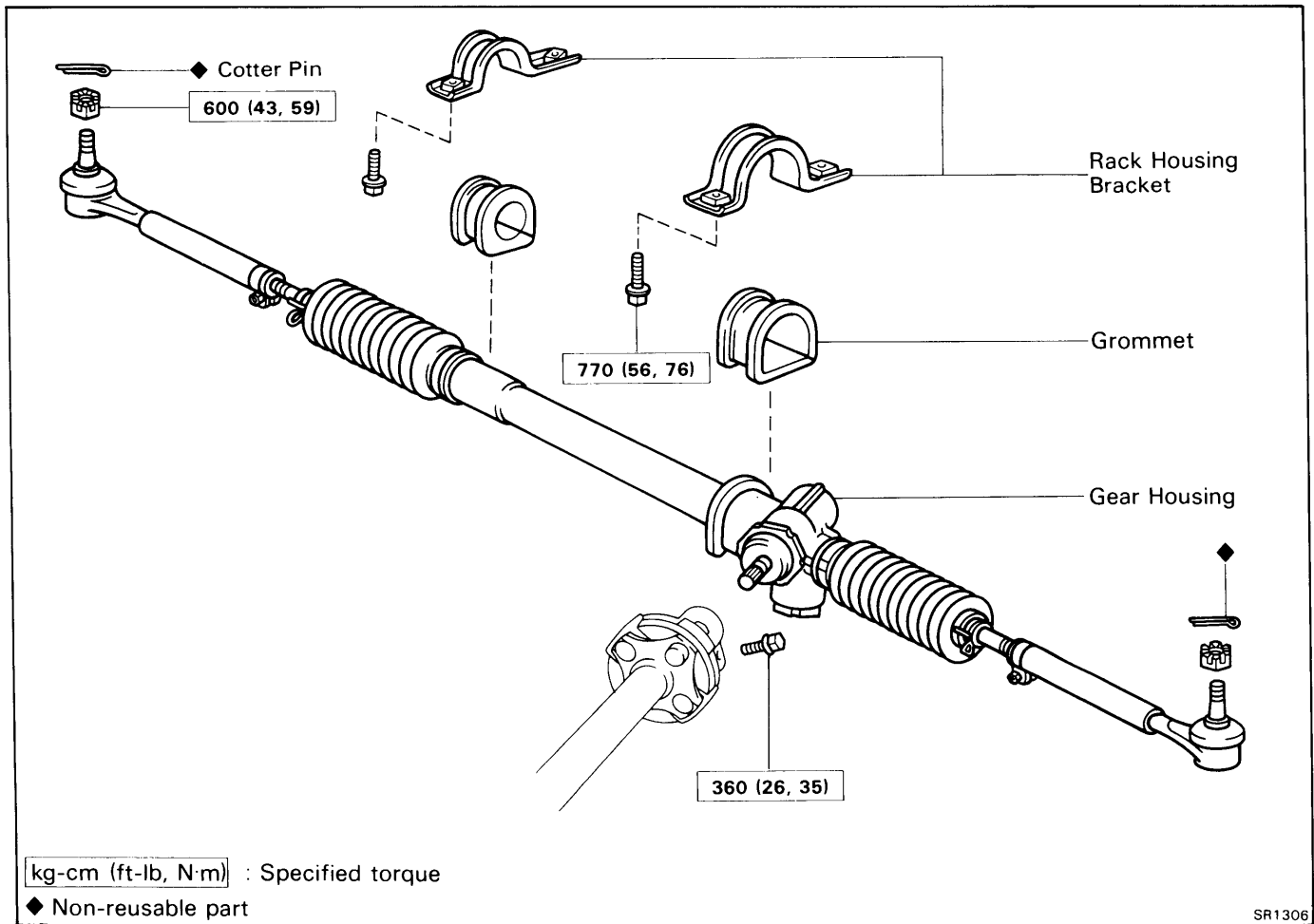

### 1. REMOVE FRONT WHEEL

### 2. DISCONNECT TIE ROD FROM KNUCKLE ARM

- Remove the cotter pin and set nut.
- Using SST, disconnect the tie rod from the knuckle arm.

SST 09610-20012

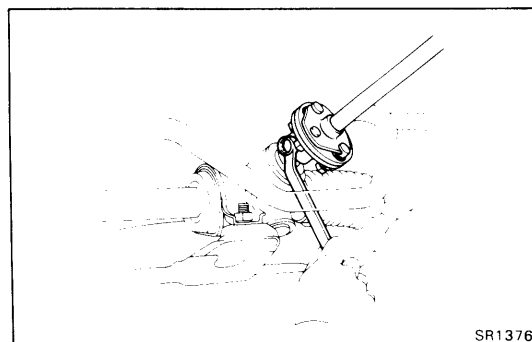

### 3. DISCONNECT TORQUE SHAFT FROM GEAR HOUSING

- Place matchmarks on the torque shaft and pinion shaft.
- Remove the set bolt.

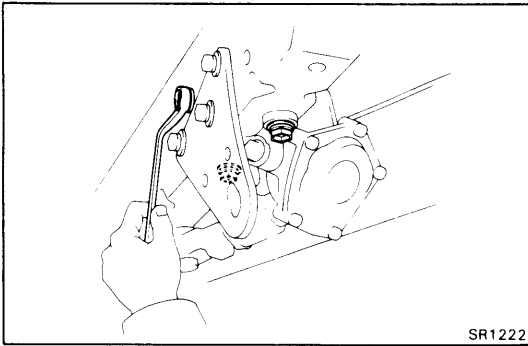

- (c) Remove the three bolts and bevel gear.
- (d) Disconnect the torque shaft from the pinion shaft.

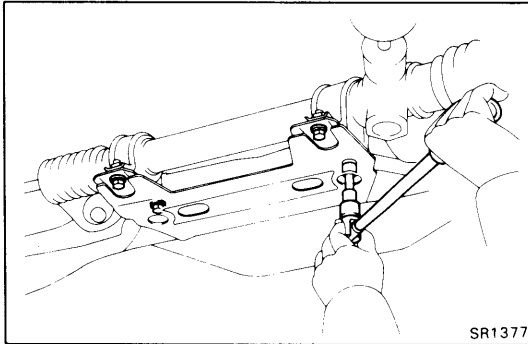

#### 4. REMOVE GEAR HOUSING

Remove the four bolts and gear housing.

COMPONENTS

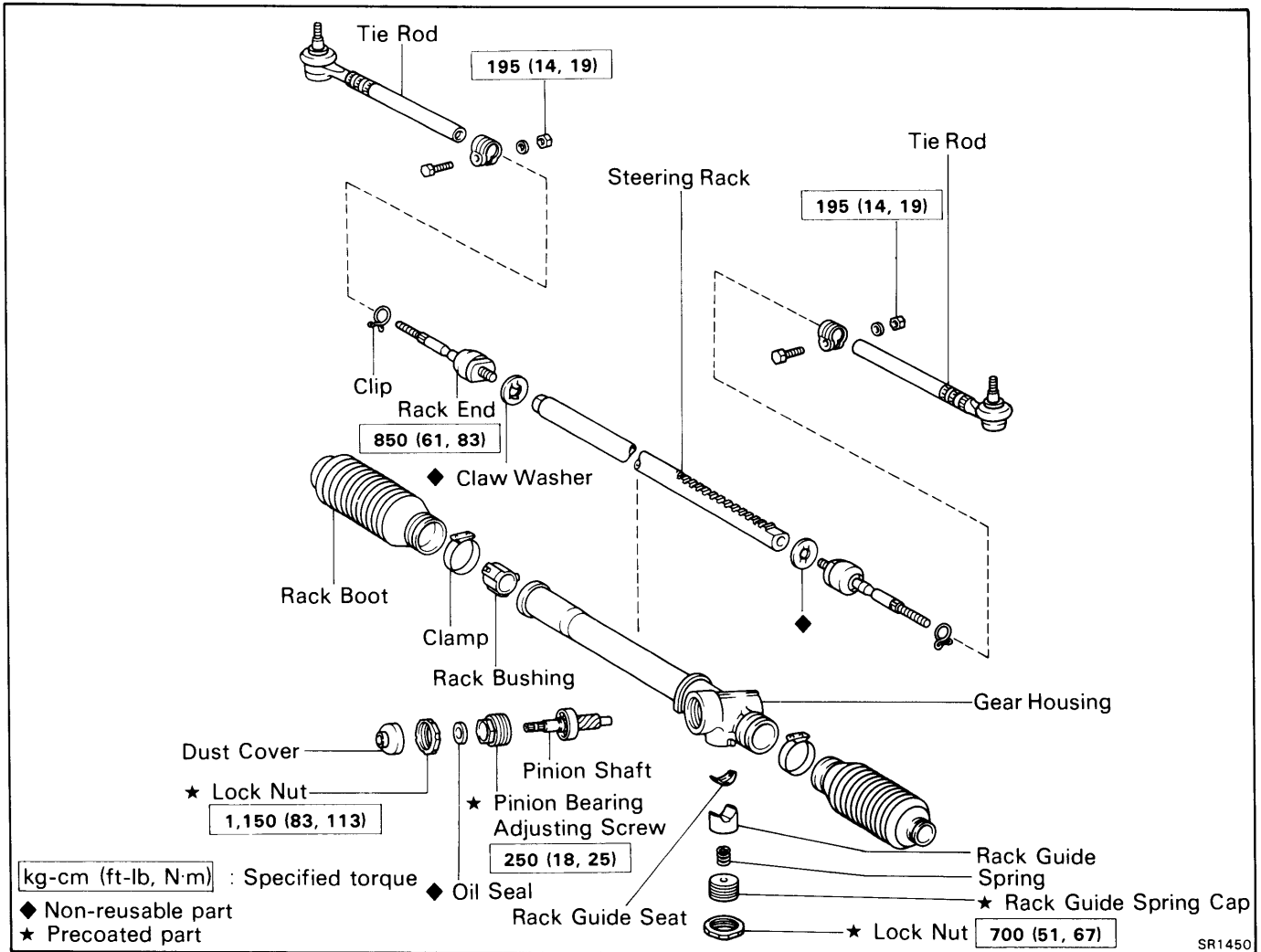

cardiagn.com

SR1450

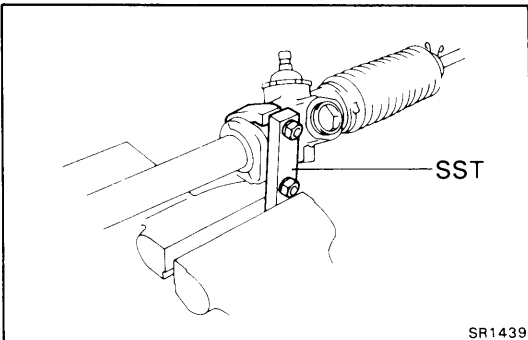

SR1439

**DISASSEMBLY OF GEAR HOUSING**

**1. CLAMP GEAR HOUSING IN VISE**

Using SST, secure the steering gear in a vise.  
 SST 09612-00012

**2. REMOVE TIE RODS**

- (a) Place matchmarks on the tie rod and rack end.
- (b) Loosen the clamp bolt and remove the tie rod from the rack end.

**3. REMOVE CLIPS, CLAMPS AND RACK BOOTS**

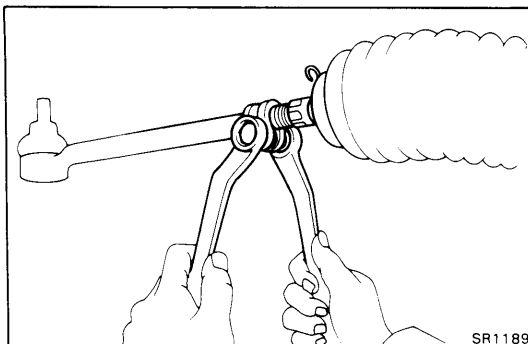

SR1189

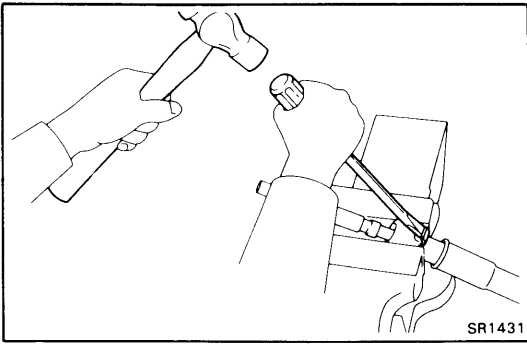
**4. REMOVE RACK ENDS AND CLAW WASHERS**

(a) Unstake the claw washer.

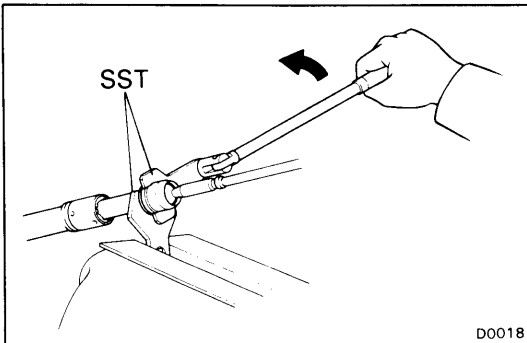
**CAUTION:** Avoid any impact to the rack.

(b) Using SST, remove the rack ends.

SST 09612-24013 (09617-24010, 09617-24030)

**NOTE:** Mark the left and right rack ends.

(c) Remove the claw washer.

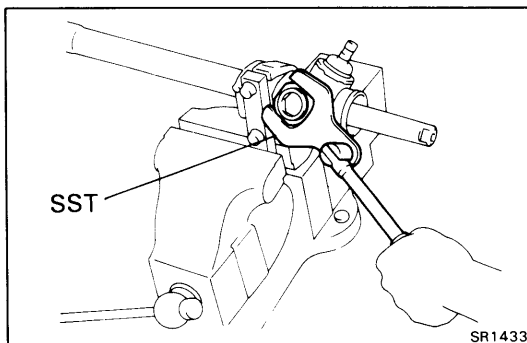
**5. REMOVE RACK GUIDE SPRING CAP LOCK NUT**

Using SST, remove the rack guide spring cap lock nut.

SST 09612-24013 (09617-24020)

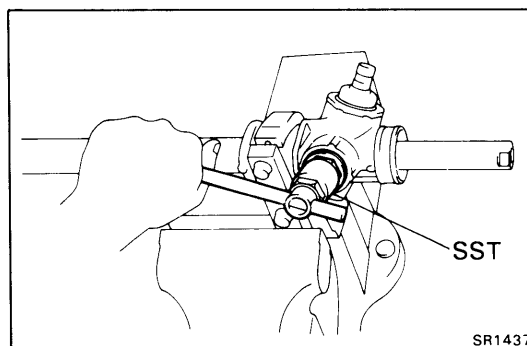
**6. REMOVE RACK GUIDE SPRING CAP**

Using SST, remove the rack guide spring cap.

SST 09612-24013 (09612-10022)

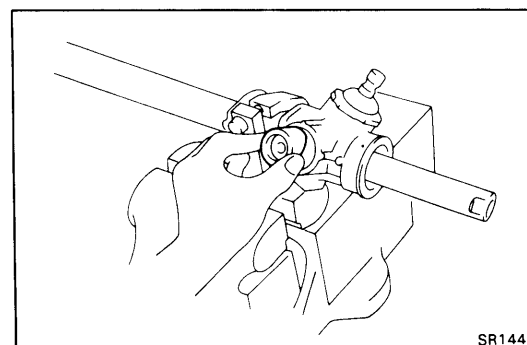
**7. REMOVE RACK GUIDE SPRING****8. REMOVE RACK GUIDE AND RACK GUIDE SEAT**

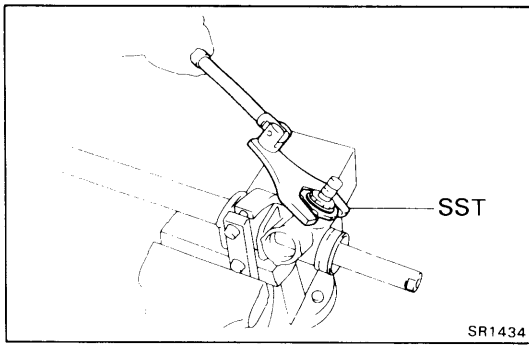

### 9. REMOVE PINION BEARING ADJUSTING SCREW LOCK NUT

Using SST, remove the pinion bearing adjusting screw lock nut.

SST 09612-10093 (09617-10010)

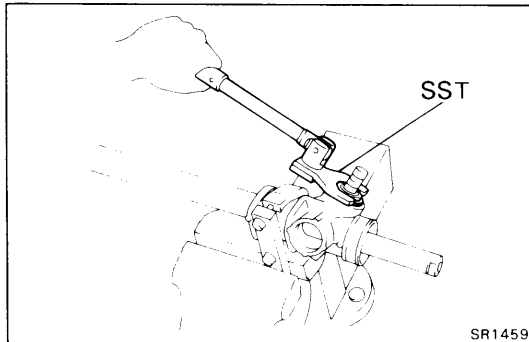

### 10. REMOVE PINION BEARING ADJUSTING SCREW

Using SST, remove the pinion bearing adjusting screw.

SST 09612-10093 (09628-10020)

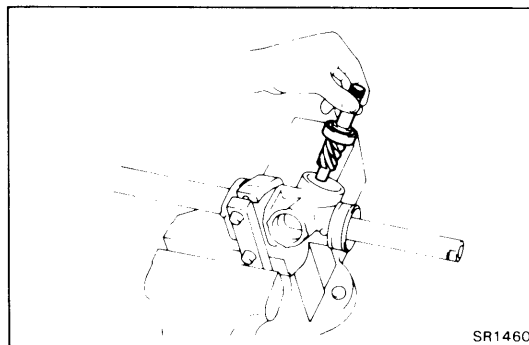

### 11. REMOVE PINION WITH BEARING

NOTE: Be careful not to damage the serrations.

- (a) Fully pull the rack from the pinion side and align the rack notched portion with the pinion.
- (b) Remove the pinion together with the upper bearing.

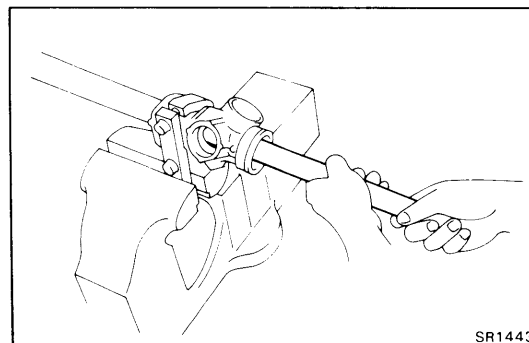

### 12. REMOVE RACK

Remove the rack from the pinion side without revolving it.

NOTE: If the rack is pulled from the tube side, there is possibility of damaging the bushing with the rack teeth surface.

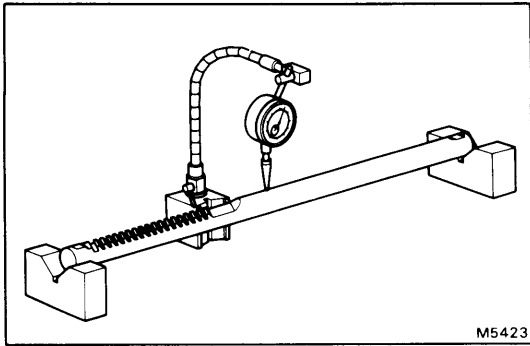

## INSPECTION AND REPAIR OF GEAR HOUSING COMPONENTS

### 1. INSPECT RACK

- (a) Check the rack for runout and for teeth wear or damage.

**Maximum runout: 0.3 mm (0.012 in.)**

- (b) Check the back surface for wear or damage.

If faulty, replace it.

**CAUTION:** Do not use a wire brush when cleaning.

### 2. IF NECESSARY, REPLACE RACK BUSHING

- (a) Using SST, remove the rack bushing.

SST 09612-24013 (09613-22011)

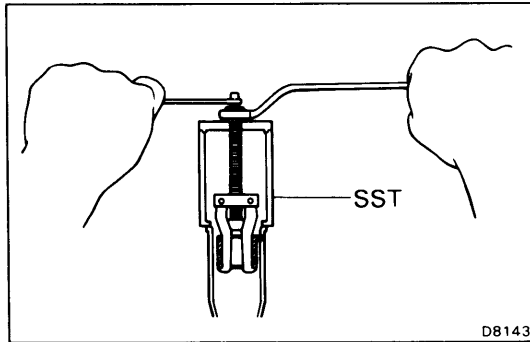

- (b) Align the three rack bushing claw to the rack housing hole and install the rack bushing.

**NOTE:** Be careful not to damage the inside of the bushing.

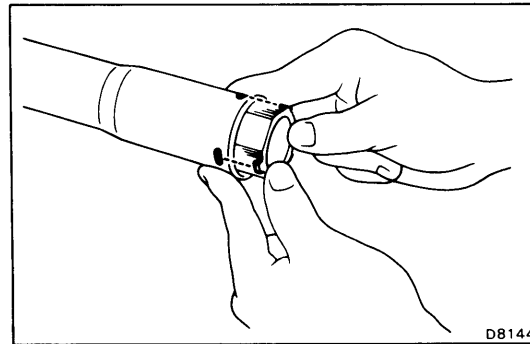

### 3. IF NECESSARY, REPLACE PINION OIL SEAL

- (a) Using a socket wrench, drive out the oil seal.

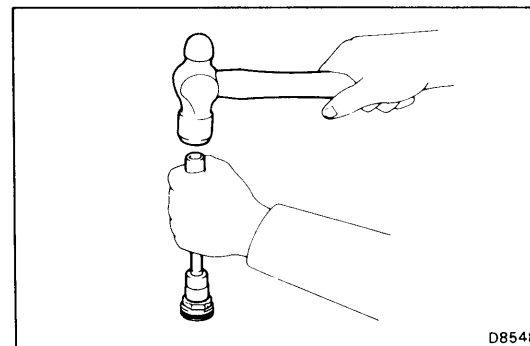

- (b) Using SST, drive in a new pinion oil seal until it is protruding 0.5 mm (0.020 in.).

SST 09612-10093 (09612-10050)

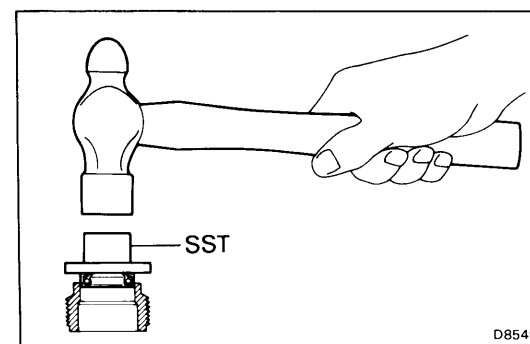

**ASSEMBLY OF GEAR HOUSING**

(See page SR-16)

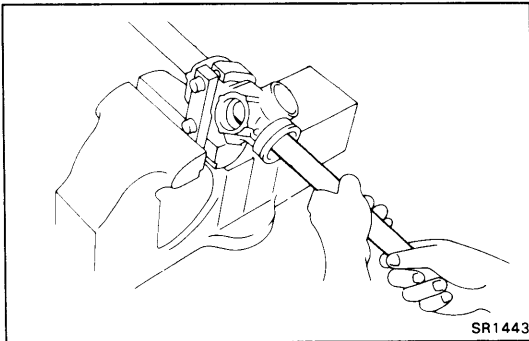
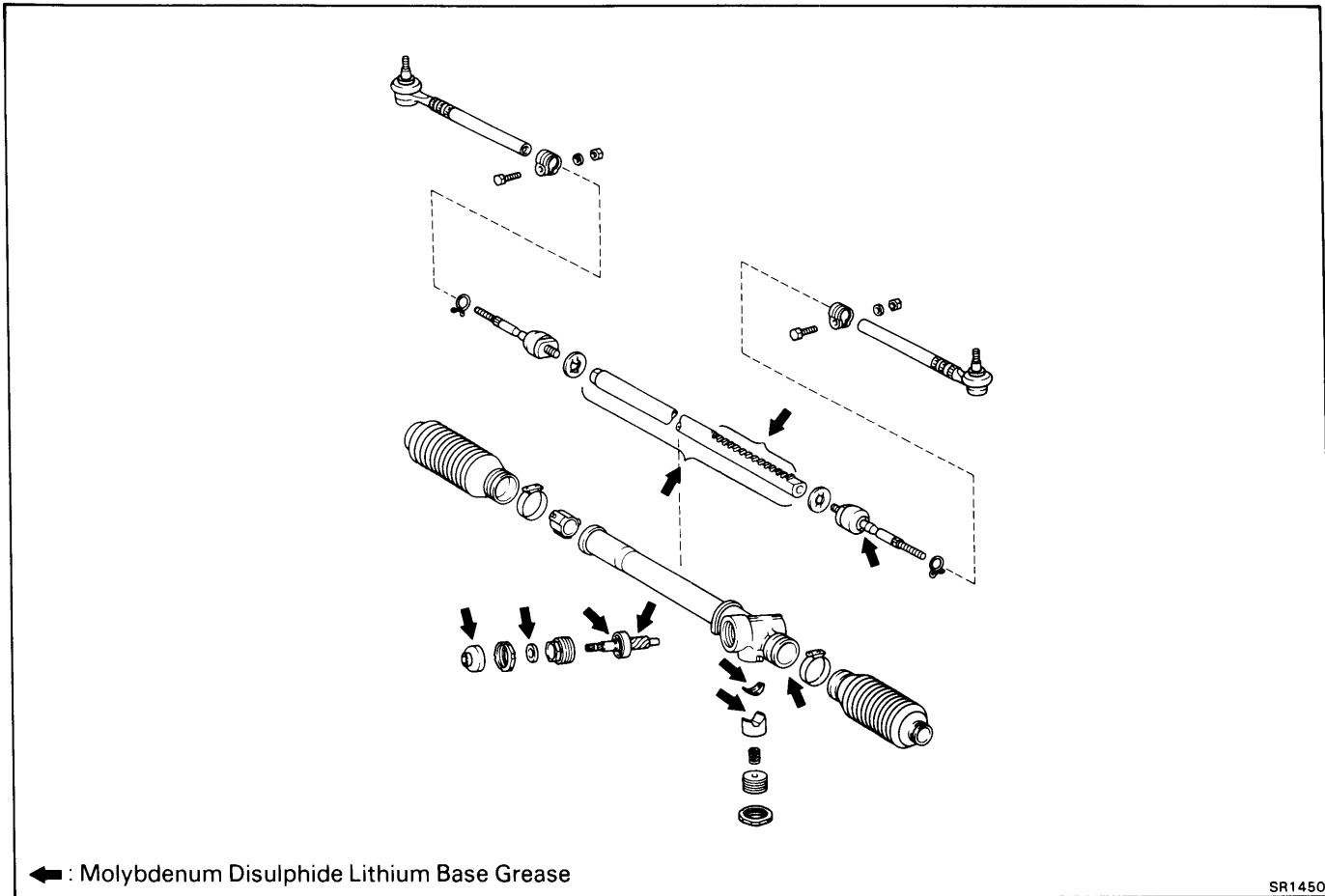
**1. PACK MOLYBDENUM DISULPHIDE LITHIUM BASE GREASE ON PARTS SHOWN****2. INSTALL RACK INTO RACK HOUSING**

- (a) From the pinion side, install the rack into the rack housing.
- (b) Set the rack notched portion so that the pinion can be positioned inside.

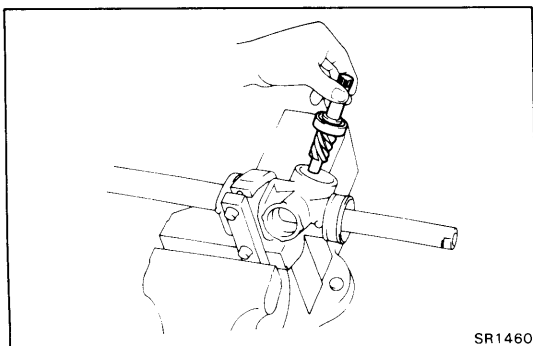
**3. INSTALL PINION INTO HOUSING**

Insure that the pinion end is securely in the lower bearing.

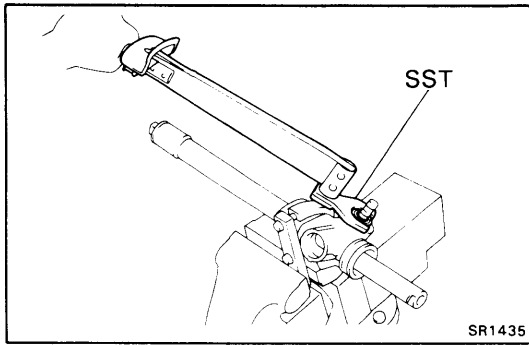
**4. INSTALL PINION BEARING ADJUSTING SCREW**

(a) Apply liquid sealer onto the screw threads.

**Sealant:** Part No. 08833-00080, THREE BOND 1344, LOCTITE 242 or equivalent

(b) Using SST, install the pinion bearing adjusting screw.  
SST 09612-10093 (09628-10020)

**Torque:** 250 kg-cm (18 ft-lb, 25 N·m)

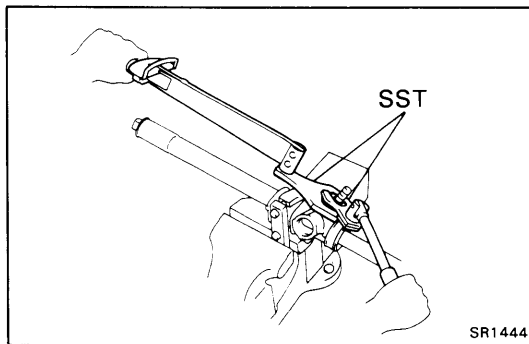
**5. INSTALL PINION BEARING ADJUSTING SCREW LOCK NUT**

(a) Apply liquid sealer onto the lock nut threads and housing contacting surface.

**Sealant:** Part No. 08833-00080, THREE BOND 1344, LOCTITE 242 or equivalent

(b) Using SST, install and torque the lock nut.  
SST 09612-10093 (09617-10010)

**Torque:** 1,150 kg-cm (83 ft-lb, 113 N·m)

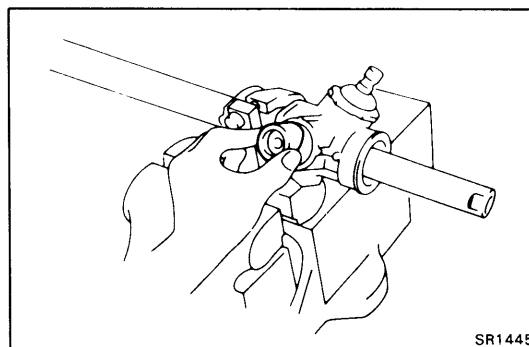
**6. INSTALL RACK GUIDE AND SPRING****7. INSTALL RACK GUIDE SPRING CAP**

(a) Apply liquid sealer onto the spring cap threads.

**Sealant:** Part No. 08833-00080, THREE BOND 1344, LOCTITE 242 or equivalent

(b) Temporarily install the spring cap and mesh the rack with the pinion.

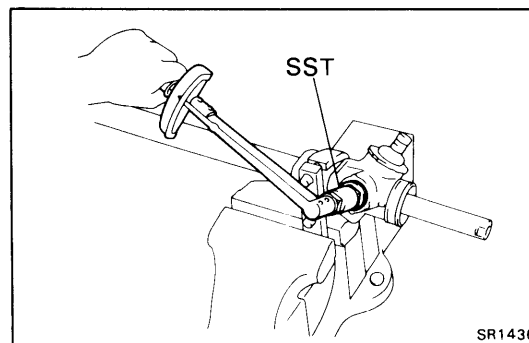
**8. ADJUST TOTAL PRELOAD**

(a) Using SST, torque the rack guide spring cap.  
SST 09612-24013 (09612-10022)

**Torque:** 250 kg-cm (18 ft-lb, 25 N·m)

(b) Return the rack guide spring cap 30°.

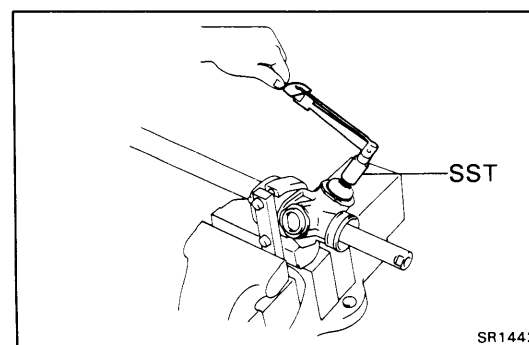

(c) Using SST and torque meter, adjust the total preload until within specification.

SST 09612-24013 (09612-10022, 09616-10010)

**Preload (turning):** 5 – 13 kg-cm  
(4.3 – 11.3 in.-lb, 0.7 – 1.3 N·m)

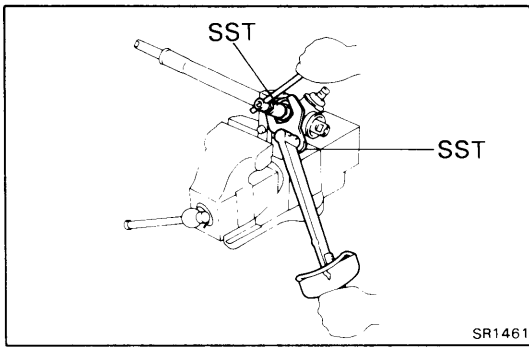
**9. INSTALL RACK GUIDE SPRING CAP LOCK NUT**

- (a) Coat liquid sealer onto the lock nut thread and housing surface.

**Sealant:** Part No. 08833-00080, THREE BOND 1344, LOCTITE 242 or equivalent

- (b) Using SST, torque the lock nut.

SST 09612-24013 (09612-10022, 09617-24020)

**Torque:** 700 kg-cm (51 ft-lb, 69 N·m)

- (c) Recheck the total preload.

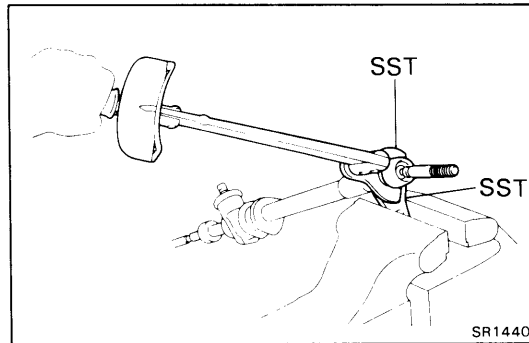
**10. INSTALL DUST COVER****11. INSTALL CLAW WASHERS AND RACK ENDS**

- (a) Install a new claw washer.

**NOTE:** Align the claw of the claw washer with the rack groove.

- (b) Using SST, install and torque the rack end.

SST 09612-24013 (09617-24010, 09617-24030)

**Torque:** 850 kg-cm (61 ft-lb, 83 N·m)

- (c) Stake the claw washer.

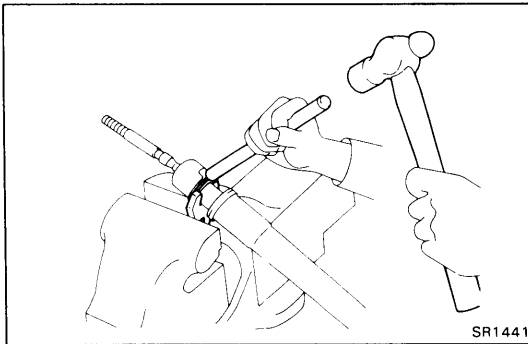
**12. INSTALL RACK BOOTS**

- (a) Install the rack boots.

**NOTE:** Be careful not to damage or twist the boots.

The left and right boots are different. Be careful not to interchange them.

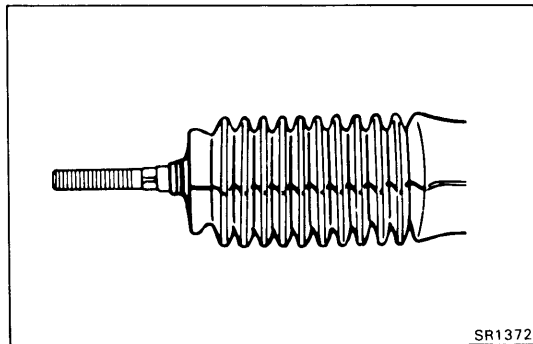

- (b) Install the clamps and clips.

- (c) Using pliers, stake the clamps and bend to upward.

**NOTE:** Face the open ends outward to avoid damage to the boots.

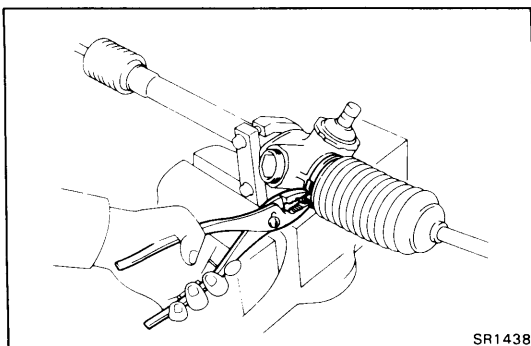

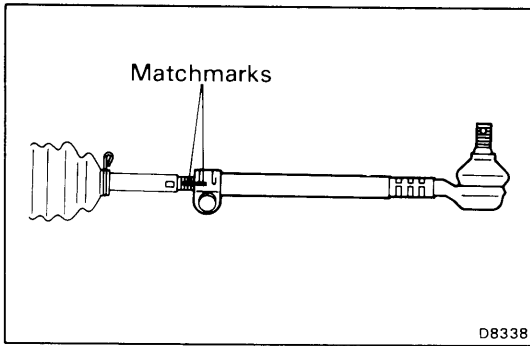
**13. INSTALL TIE RODS**

- (a) Screw the tie rods onto the rack ends until the matchmarks are aligned.
- (b) After adjusting toe-in, torque the clamp bolts.

**Torque: 195 kg-cm (14 ft-lb, 19 N·m)**

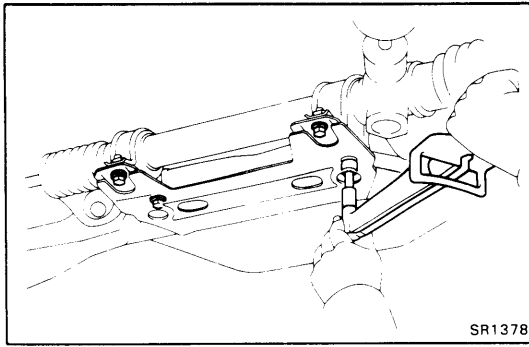

SR1378

## INSTALLATION OF GEAR HOUSING

(See page SR-14)

### 1. INSTALL GEAR HOUSING

Install the gear housing with the four bolts to the body and torque the four bolts.

**Torque: 770 kg-cm (56 ft-lb, 76 N·m)**

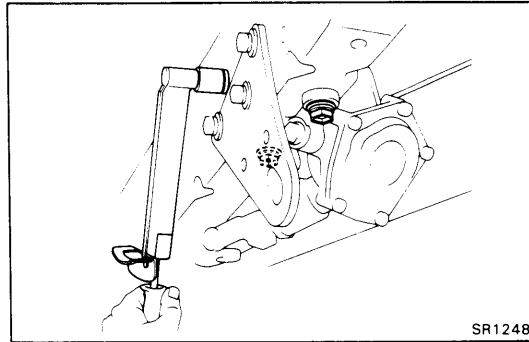

SR1248

### 2. CONNECT TORQUE SHAFT TO GEAR HOUSING

(a) Align the matchmarks on the torque shaft and pinion shaft.

(b) Install the bevel gear with the three bolts and torque the three bolts.

**Torque: 400 kg-cm (29 ft-lb, 39 N·m)**

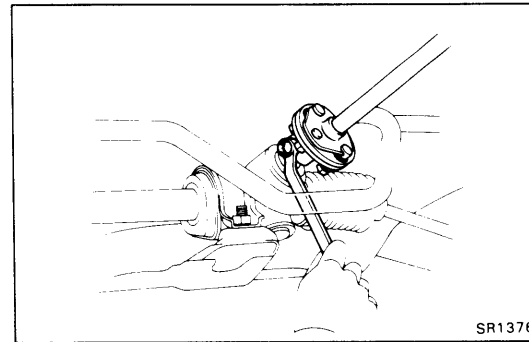

SR1376

(c) Torque the coupling bolts.

**Torque: 360 kg-cm (26 ft-lb, 35 N·m)**

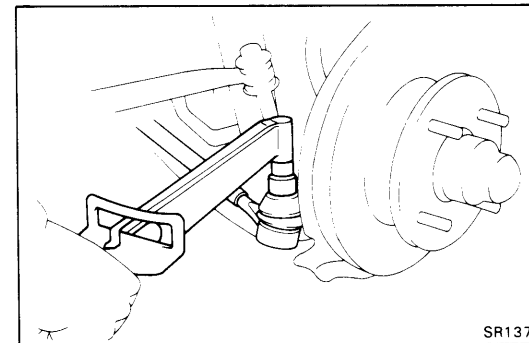

SR1379

### 3. CONNECT TIE ROD TO KNUCKLE ARM

(a) Install the tie rod to the knuckle arm and torque the mount nut.

**Torque: 600 kg-cm (43 ft-lb, 59 N·m)**

(b) Install a new cotter pin.

### 4. INSTALL WHEEL

### 5. CHECK STEERING WHEEL FREEPLAY

### 6. CHECK TOE-IN (See page FA-6)

### 7. CHECK STEERING WHEEL CENTER POINT

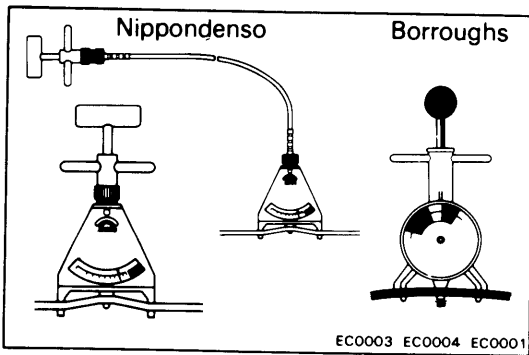

## POWER STEERING

### On-Vehicle Inspection

#### CHECK OF DRIVE BELT TENSION

Using a belt tension gauge, check the drive belt tension.

Belt tension gauge:

Nippondenso BTG-20 (95506-00020) or  
Borroughs No. BT-33-73F

Drive belt tension:

**New belt**  $125 \pm 25$  lb

**Used belt**  $80 \pm 20$  lb

If necessary, adjust the drive belt tension.

NOTE:

- "New belt" refers to a belt which has been used less than 5 minutes on a running engine.
- "Used belt" refers to a belt which has been used on a running engine for 5 minutes or more.

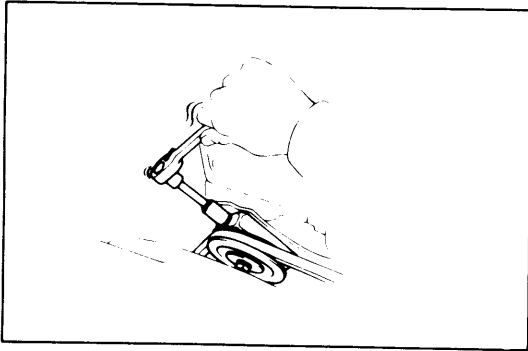

#### FLUID LEVEL CHECK

##### 1. KEEP VEHICLE LEVEL

##### 2. BOOST FLUID TEMPERATURE

With the engine idling at 1,000 rpm or less, turn the steering wheel from lock to lock several times to boost fluid temperature.

**Fluid temperature:**  $60^{\circ}\text{C}$  ( $140^{\circ}\text{F}$ )

##### 3. CHECK FOR FOAMING OR EMULSIFICATION

NOTE: Foaming and emulsification indicate the existence of air in the system or that the fluid level is low.

##### 4. CHECK FLUID LEVEL IN RESERVOIR

Check the fluid level and add fluid if necessary.

**Fluid:** ATF DEXRON® or DEXRON® II

NOTE: Check that the fluid level is within the HOT LEVEL of the dipstick. If the fluid is cold, check that it is within the COLD LEVEL of dipstick.

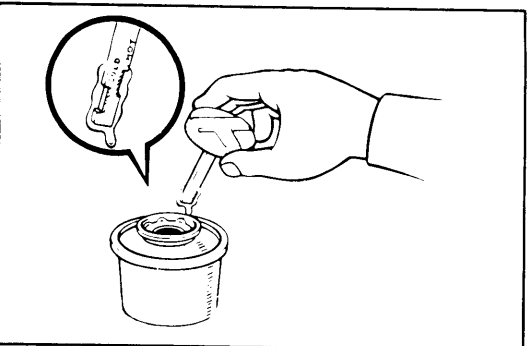
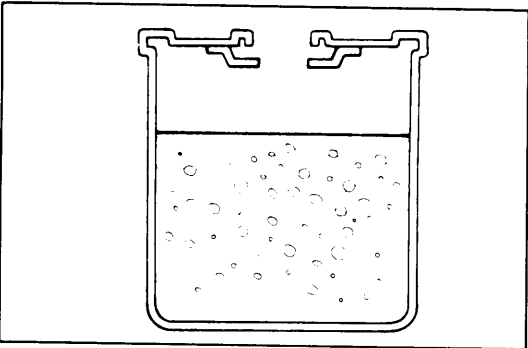
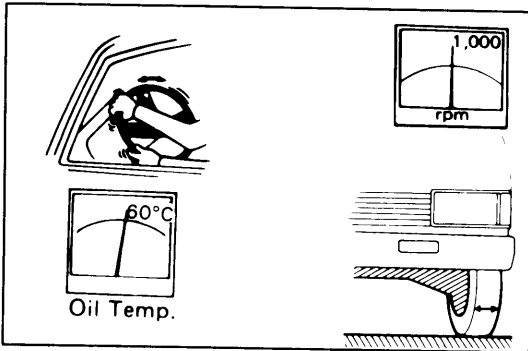

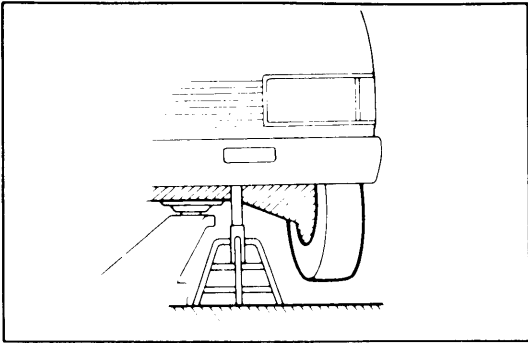

## REPLACEMENT OF POWER STEERING FLUID

1. JACK UP FRONT OF VEHICLE AND SUPPORT IT WITH STANDS

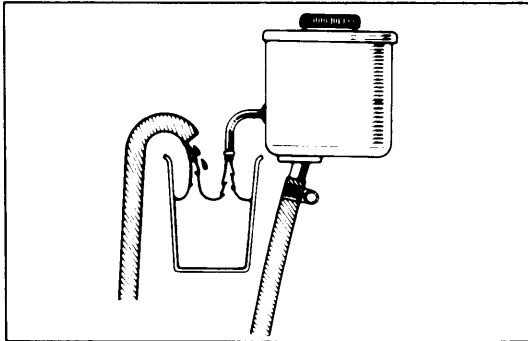

2. REMOVE FLUID RETURN HOSE FROM OIL RESERVOIR AND DRAIN FLUID INTO A CONTAINER

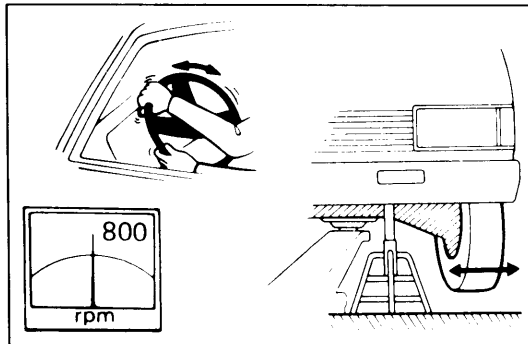

3. WITH ENGINE IDLING, TURN STEERING WHEEL FROM FULL LEFT TO FULL RIGHT WHILE DRAINING FLUID

4. STOP ENGINE

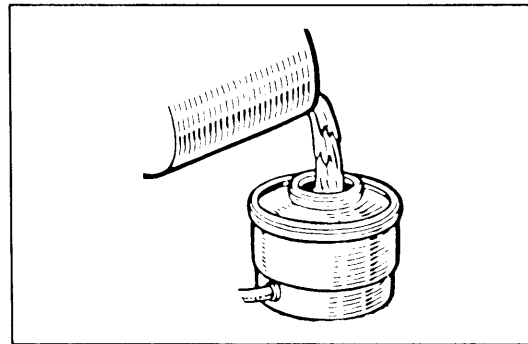

5. FILL RESERVOIR WITH FRESH FLUID  
Fluid: ATF DEXRON® or DEXRON® II

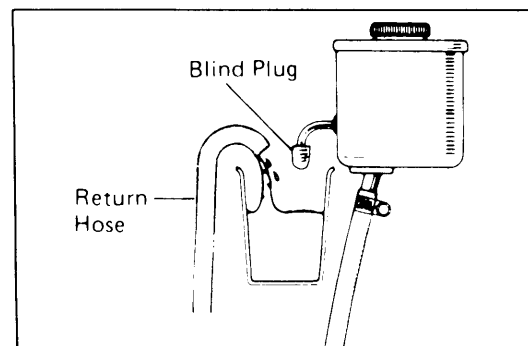

6. START ENGINE AND RUN IT AT 1,000 RPM

After 1 or 2 seconds, fluid will begin to discharge from the return hose. Stop the engine immediately as soon as fluid begins to discharge.

7. REPEAT STEPS 5 AND 6 FOUR OR FIVE TIMES UNTIL THERE IS NO MORE AIR IN FLUID

8. CONNECT RETURN HOSE TO OIL RESERVOIR

9. BLEED POWER STEERING SYSTEM

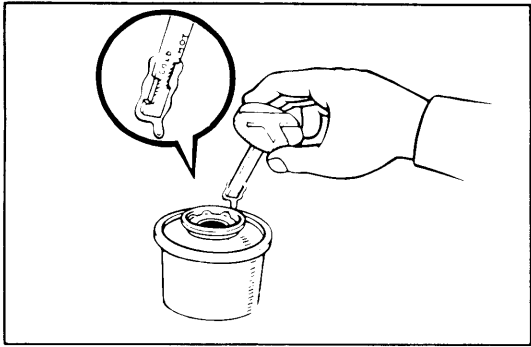

## Bleeding of Power Steering System

### 1. CHECK FLUID LEVEL IN RESERVOIR

Check the fluid level and add fluid if necessary.

**Fluid: ATF DEXRON® or DEXRON® II**

**NOTE:** Check that the fluid level is within the **HOT LEVEL** of the dipstick. If the fluid is cold, check that it is within the **COLD LEVEL** of the dipstick.

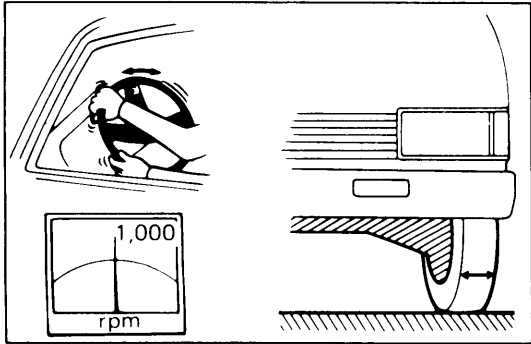

### 2. START ENGINE AND TURN STEERING WHEEL FULLY IN BOTH DIRECTIONS THREE OR FOUR TIMES

Run the engine at 1,000 rpm or less.

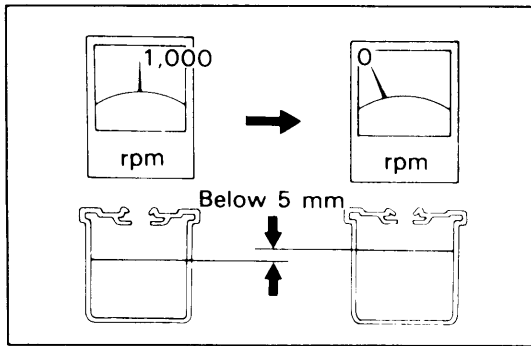

### 3. CHECK THAT FLUID IN RESERVOIR IS NOT FOAMY OR CLOUDY AND DOES NOT RISE OVER MAXIMUM WHEN ENGINE IS STOPPED

Measure the fluid level with the engine running. Stop the engine and measure the fluid level.

**Maximum rise: 5 mm (0.20 in.)**

If a problem is found, repeat steps 6 and 7 on page SR-26. Repair the PS pump if the problem persists.

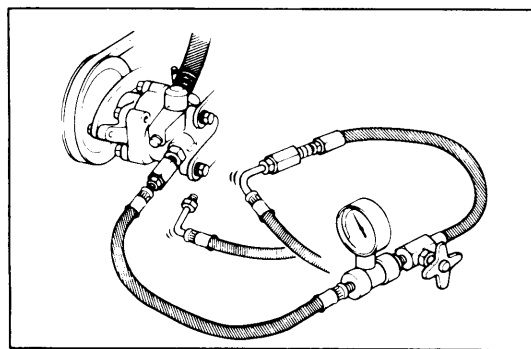

## Oil Pressure Check

### 1. CONNECT PRESSURE GAUGE

(a) Using SST, remove the pressure line from the PS pump.

SST 09631-22020

(b) Connect the gauge side of the pressure gauge to the PS pump.

(c) Connect the valve side of the pressure gauge to the pressure line.

(d) Bleed the system. Start the engine and turn the wheel fully in both directions two or three times.

(e) Check that the fluid level is correct.

### 2. CHECK THAT FLUID TEMPERATURE IS AT LEAST 60°C (140°F)

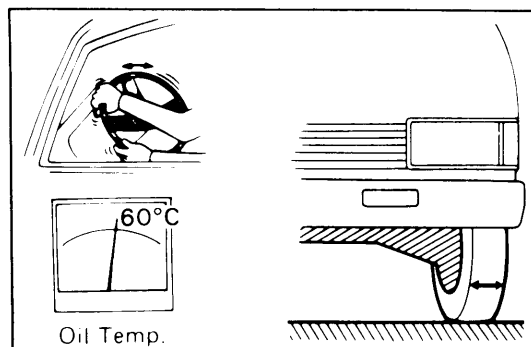

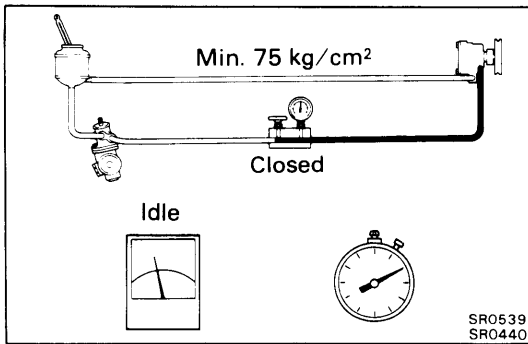

### 3. START ENGINE AND RUN IT AT IDLE

### 4. CHECK FLUID PRESSURE READING WITH VALVE CLOSED

Close the pressure gauge valve and observe the reading on the gauge.

**Minimum pressure: 75 kg/cm<sup>2</sup> (1,067 psi, 7,355 kPa)**

**NOTE:** Do not keep the valve closed for more than 10 seconds.

If pressure is low, repair or replace the PS pump.

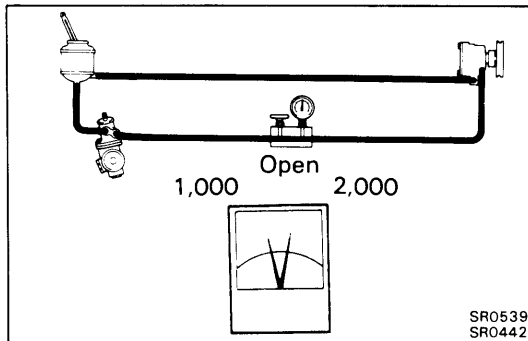

### 5. OPEN VALVE FULLY

### 6. CHECK AND RECORD PRESSURE READING AT 1,000 RPM

### 7. CHECK AND RECORD PRESSURE READING AT 3,000 RPM

Check that there is less than 5 kg/cm<sup>2</sup> (71 psi, 490 kPa) difference in pressure between the 1,000 rpm and 3,000 rpm checks.

If the difference is greater, repair or replace the PS pump flow control valve.

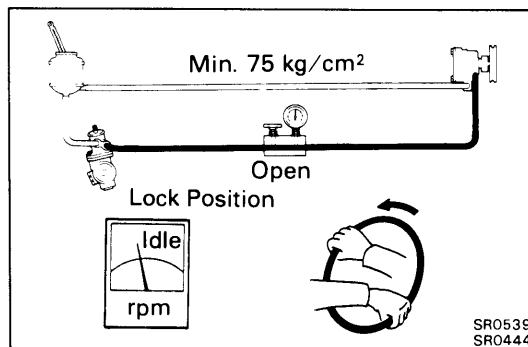

### 8. CHECK PRESSURE READING WITH STEERING WHEEL TURNED TO FULL LOCK

Be sure the pressure gauge valve is fully opened and the engine idling.

**Minimum pressure: 75 kg/cm<sup>2</sup> (1,067 psi, 7,355 kPa)**

If pressure is low, the gear housing has an internal leak and must be repaired or replaced.

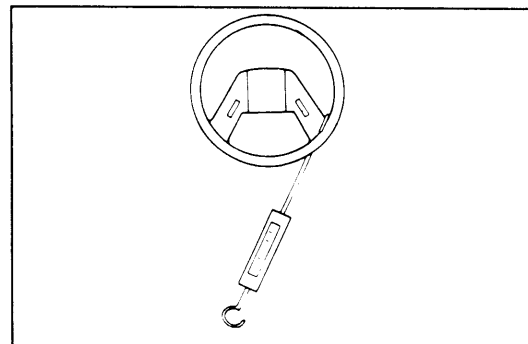

### 9. MEASURE STEERING EFFORT

Center the steering wheel and run the engine at idle.

Using a scale, measure the steering effort in both directions.

**Maximum steering effort: 4 kg (8.8 lb, 39 N)**

If steering effort is excessive, repair the power steering unit.

**NOTE:** Be sure to consider tire type, pressure and contact surface before making your diagnosis.

## Power Steering Pump

### REMOVAL OF POWER STEERING PUMP

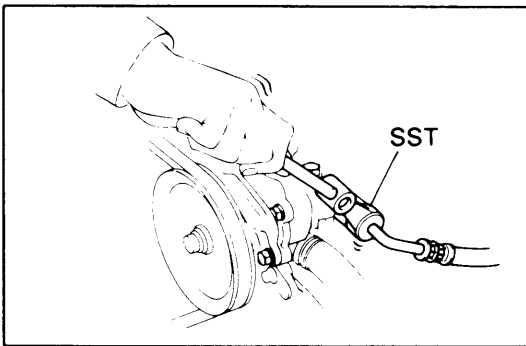
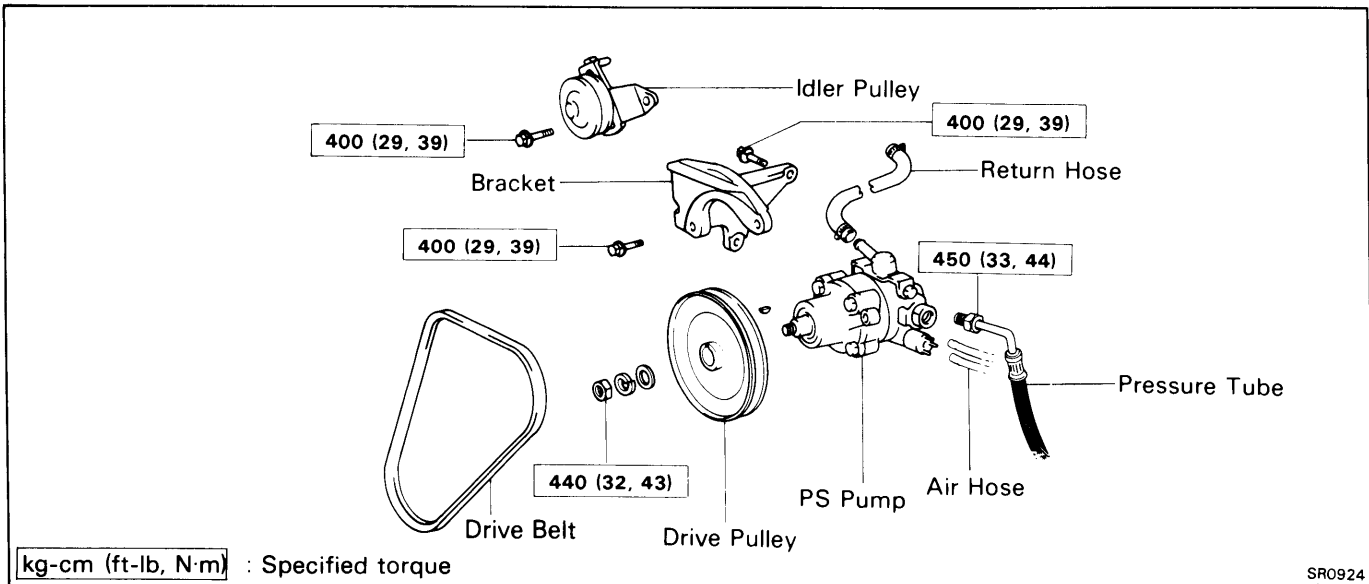

1. **DISCONNECT AIR HOSES FROM AIR CONTROL VALVE**
2. **DRAIN FLUID FROM RESERVOIR TANK**
3. **DISCONNECT RETURN HOSE FROM POWER STEERING PUMP**
4. **DISCONNECT PRESSURE TUBE FROM POWER STEERING PUMP**

Using SST, loosen and disconnect the pressure tube.

SST 09631-22020

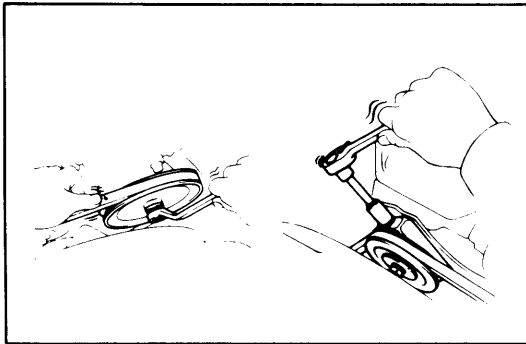

5. **REMOVE DRIVE BELT AND PULLEY**

- (a) Push on the drive belt to hold the pulley in place and remove the pulley set nut.
- (b) Loosen the drive belt adjust bolt.
- (c) Remove the drive belt.
- (d) Remove the pulley and woodruff key.

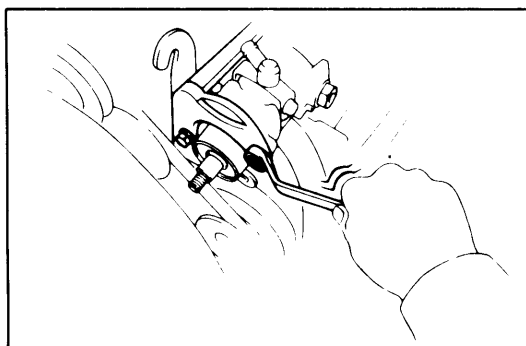

6. **REMOVE POWER STEERING PUMP**

Remove the PS pump mount bolts, and remove the PS pump from the bracket.

## COMPONENTS

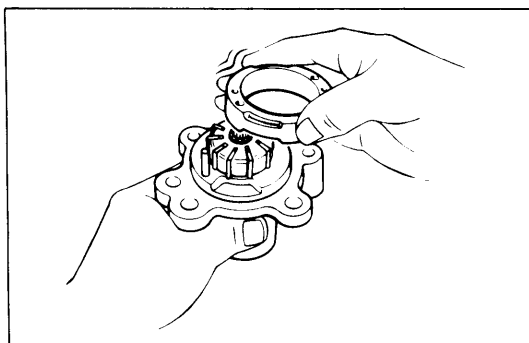
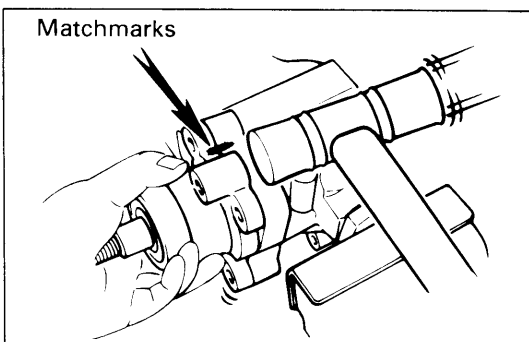
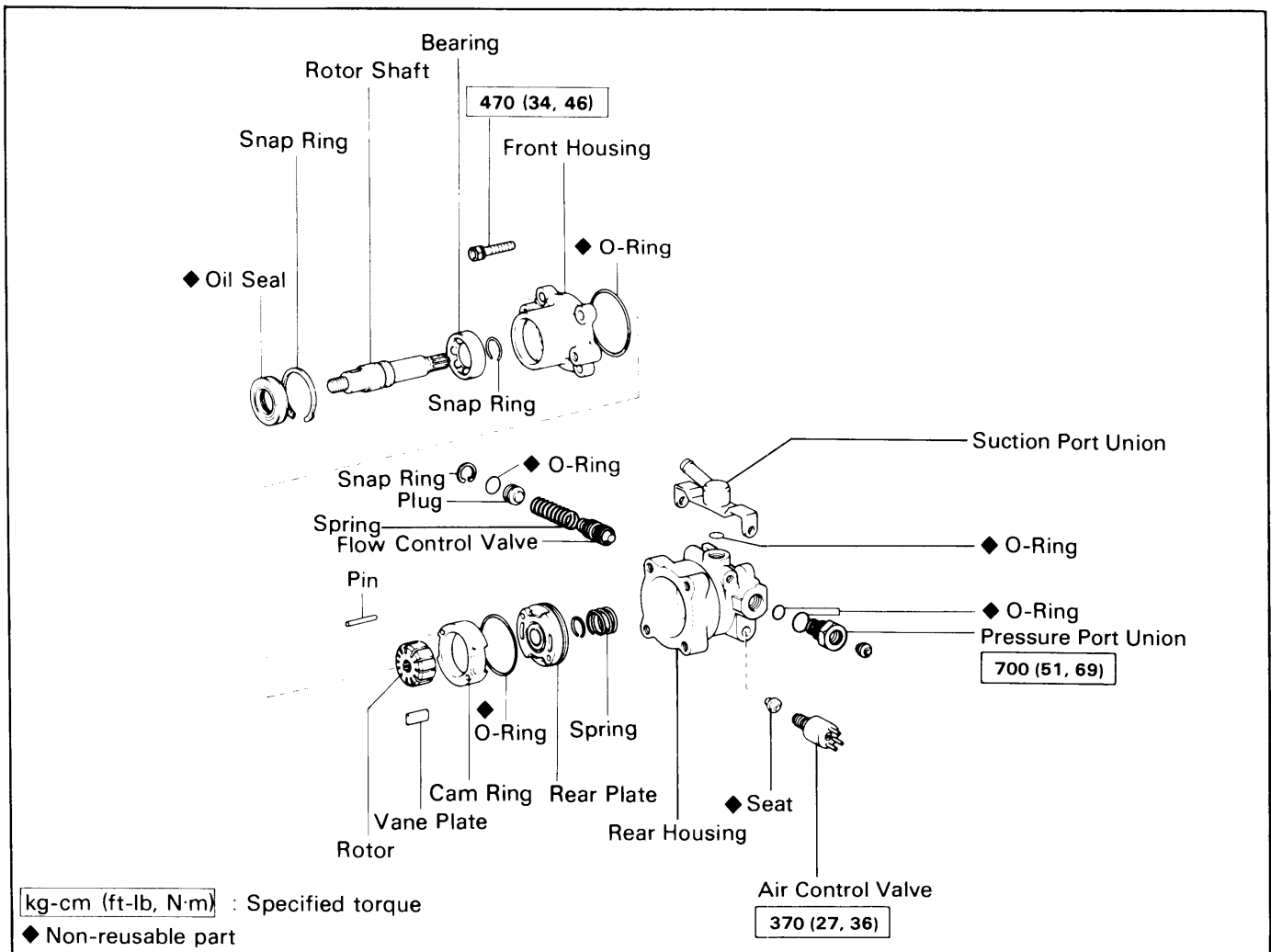

## DISASSEMBLY OF POWER STEERING PUMP

1. CLAMP POWER STEERING PUMP IN VISE  
**CAUTION:** Do not tighten the vise too tight.
2. REMOVE AIR CONTROL VALVE FROM REAR HOUSING
3. REMOVE UNION FROM REAR HOUSING
4. MARK FRONT AND REAR HOUSINGS TO INSURE CORRECT REASSEMBLY
5. REMOVE FRONT HOUSING
  - (a) Remove the four front housing bolts.
  - (b) Using a plastic hammer, tap off the front housing.**CAUTION:** Be careful that the vane plates, rotor and cam ring do not fall out.
6. REMOVE CAM RING, ROTOR AND VANE PLATES  
**CAUTION:** Be careful not to scratch the cam ring, rotor or vane plates.

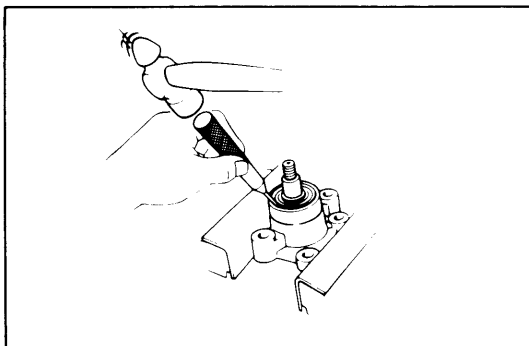

### 7. REMOVE ROTOR SHAFT

(a) Clamp the front housing in a vise.

**CAUTION:** Do not tighten the vise too tight.

(b) Using a chisel and hammer, pry off the oil seal.

(c) Using snap ring pliers, remove the snap ring.

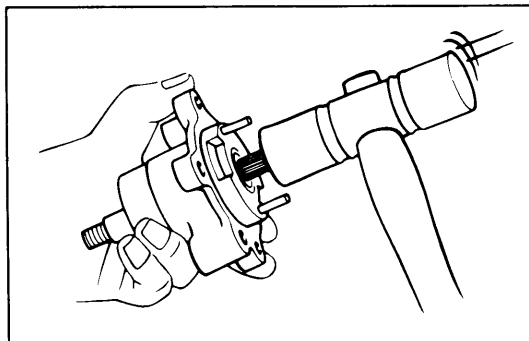

(d) Using a plastic hammer, lightly tap the rotor shaft out of the front housing.

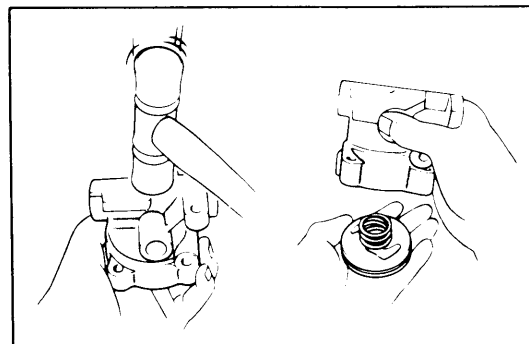

### 8. REMOVE REAR PLATE AND SPRING

Using a plastic hammer, tap the bottom end of the rear housing, and remove the rear plate and spring.

**CAUTION:** Avoid gripping the rear plate with pliers as this could damage it.

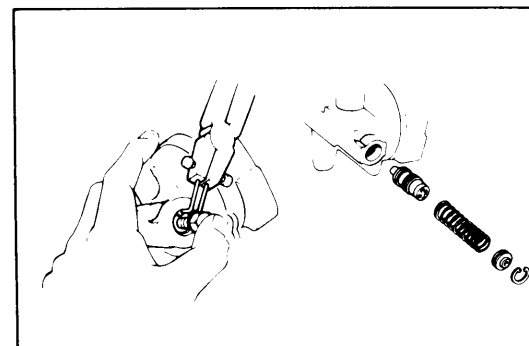

### 9. REMOVE FLOW CONTROL VALVE

(a) Temporarily install a bolt to the plug.

(b) Push the bolt and remove the snap ring with snap ring pliers.

(c) Pull out the bolt and remove the plug.

(d) Remove the spring and flow control valve by hand.

**CAUTION:** Use care not to drop, scratch or nick this valve.

### 10. REMOVE PRESSURE PORT UNION

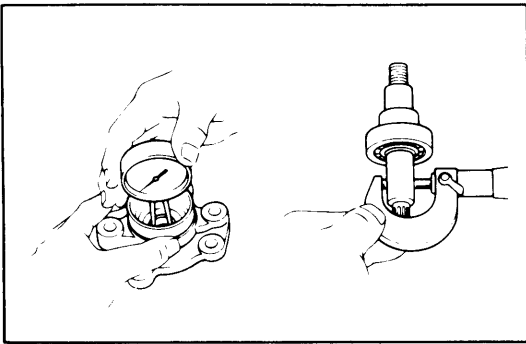

## INSPECTION OF POWER STEERING PUMP

### 1. INSPECT BUSHING AND MEASURE BUSHING OIL CLEARANCE

- Check the bushing for wear or damage. The bushing cannot be replaced separately.  
If wear or damage is found, replace entire housing.
- Check the oil clearance between the bushing and rotor shaft.

**Maximum oil clearance: 0.07 mm (0.0028 in.)**

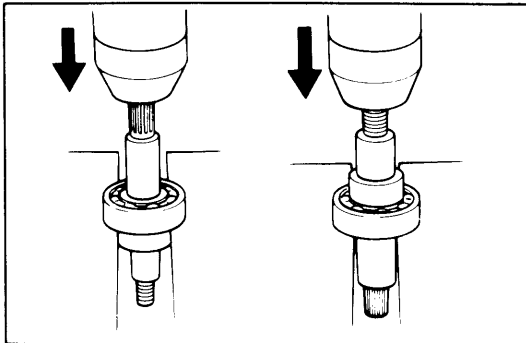

### 2. IF NECESSARY, REPLACE ROTOR SHAFT BEARING

- Using snap ring pliers, remove the snap ring.
- Using a press, press out the bearing.
- Using a press, press in the bearing.
- Using snap ring pliers, install the snap ring.

### 3. INSPECT AND MEASURE VANE PLATES

- Check the vane plates for wear or scratches.
- Measure the length, height and thickness of the vane plates.

**Minimum length: 14.97 mm (0.5894 in.)**

**Minimum height: 7.8 mm (0.307 in.)**

**Minimum thickness: 1.7 mm (0.067 in.)**

- Measure the clearance between the vane plate and rotor groove.

**Maximum clearance: 0.06 mm (0.0024 in.)**

**NOTE:** There are five vane lengths with the following rotor and cam ring numbers:

Rotor and cam ring number	Vane length	mm (in.)
None	14.996–14.998	(0.5904–0.5905)
1	14.994–14.996	(0.5903–0.5904)
2	14.992–14.994	(0.5902–0.5903)
3	14.990–14.992	(0.59016–0.59024)
4	14.988–14.990	(0.5901–0.5902)

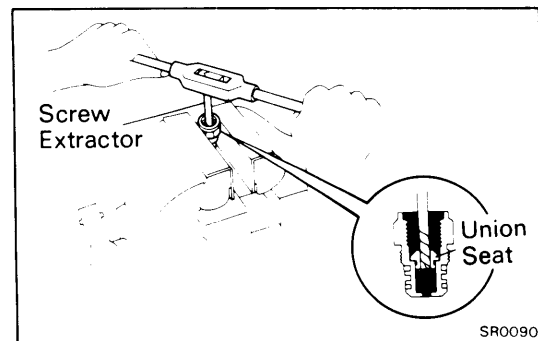
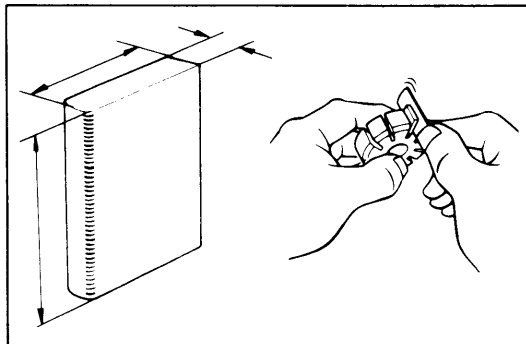

### 4. IF NECESSARY, REPLACE UNION SEAT

- Using a screw extractor, remove the union seat.
- Install a new union seat.

**NOTE:** Only floating type parts are available.

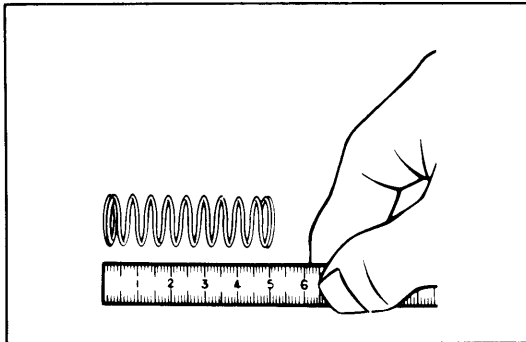
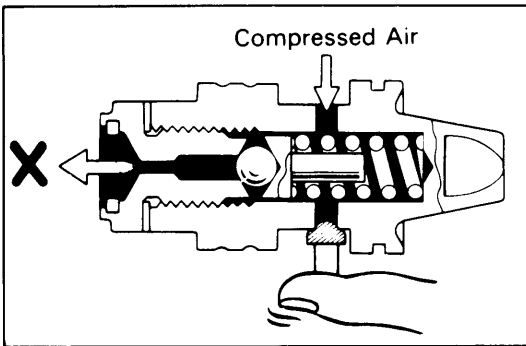

#### 5. INSPECT FLOW CONTROL VALVE AND MEASURE SPRING

- (a) Check the flow control valve for wear or damage.
- (b) Apply fluid to the valve and check that it falls smoothly into the valve hole by its own weight.
- (c) Check the flow control valve for leakage.
  - Close one of the holes and apply compressed air [4 or 5 kg/cm<sup>2</sup> (57 or 71 psi, 392 or 490 kPa)] into the opposite side.
  - Confirm that air does not come out from the end hole.

If necessary, replace the valve with one having the same letter as on the rear housing.

- (d) Check that the spring is within specification.

**Standard length: 50.0 mm (1.969 in.)**

**Minimum length: 47.0 mm (1.850 in.)**

If the spring is not within specification, replace it.

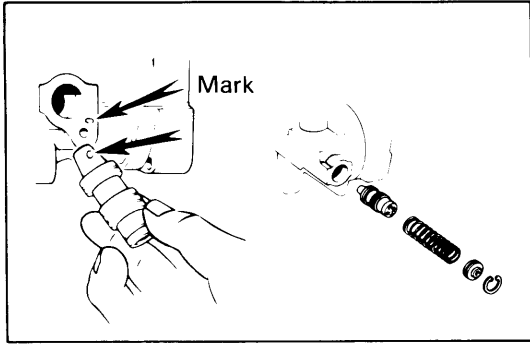

## ASSEMBLY OF POWER STEERING PUMP

(See page SR-30)

### 1. INSTALL FLOW CONTROL VALVE

NOTE: Be sure the letter inscribed on the flow control valve matches the letter stamped on the rear of the pump body.

Inscribed mark: **A, B, C, D, E or F**

Install the flow control valve, spring, plug and snap ring.

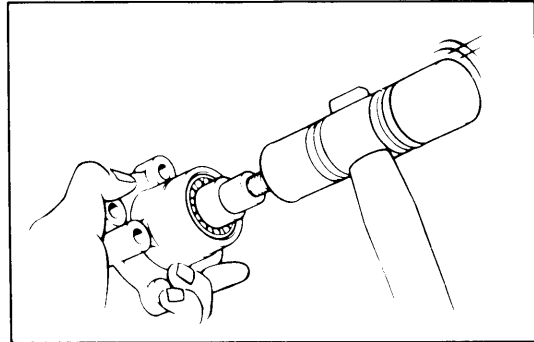

### 2. INSTALL PRESSURE PORT UNION

Install and torque the union.

Torque: **700 kg-cm (51 ft-lb, 69 N·m)**

### 3. INSTALL ROTOR SHAFT TO FRONT HOUSING

Install the rotor shaft into the front housing by tapping it in with a plastic hammer.

### 4. INSTALL SNAP RING

Using snap ring pliers, install the snap ring to the front housing.

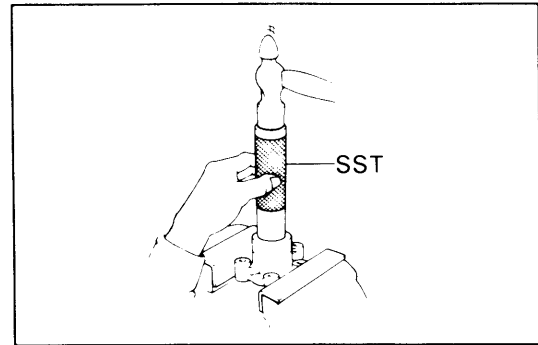

### 5. INSTALL OIL SEAL

(a) Apply a light coat of MP grease to a new oil seal lip.

(b) Using SST and a hammer, install the oil seal.

SST 09608-30012 (09608-04020)

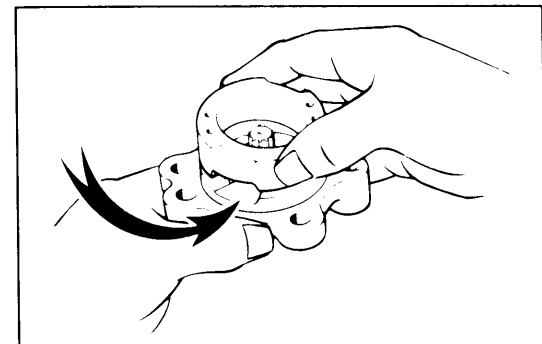

### 6. INSTALL O-RING

### 7. INSTALL CAM RING

Align the fluid passages of the cam ring and front housing, and install the cam ring.

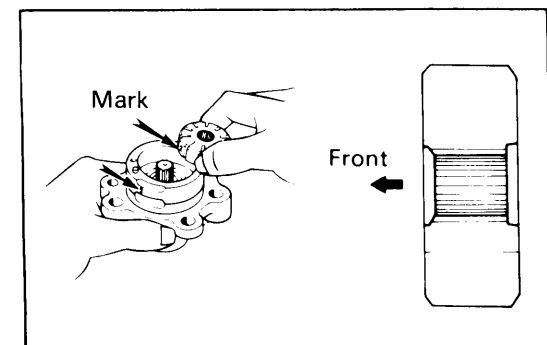

### 8. INSTALL ROTOR

Install the rotor with the chamfered end facing toward the front.

NOTE: Be sure the letters inscribed on the cam ring and rotor match.

Inscribed mark: **1, 2, 3, 4 or None**

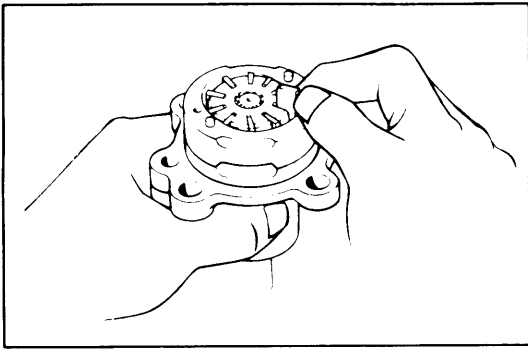
**9. INSTALL VANE PLATES**

Install the vane plates with the round end facing outward.

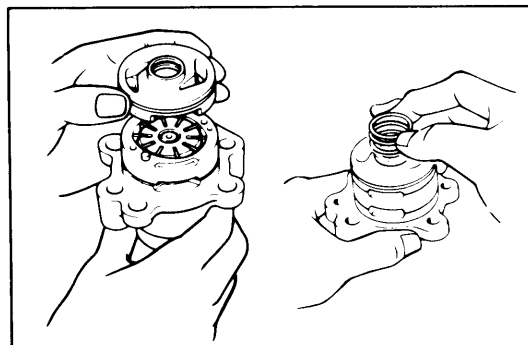
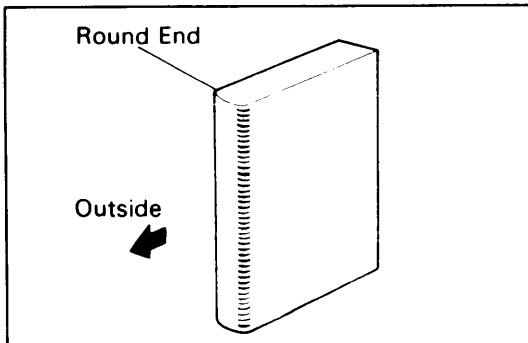
**10. INSTALL REAR PLATE AND SPRING**

- (a) Align the fluid passages of the rear plate and cam ring, and install the rear plate with the spring.
- (b) Place the spring on the rear plate.

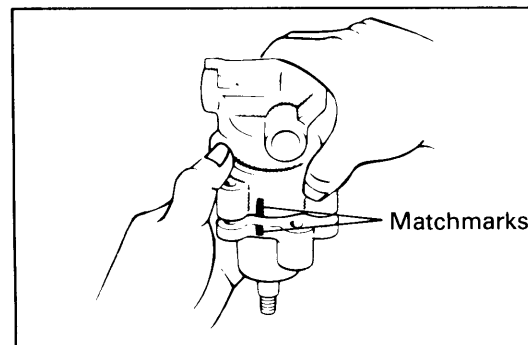
**11. INSTALL REAR HOUSING**

- (a) Align the matchmarks on the front and rear housing, and assemble them.
- (b) Tighten the front and rear housing mount bolts by hand.

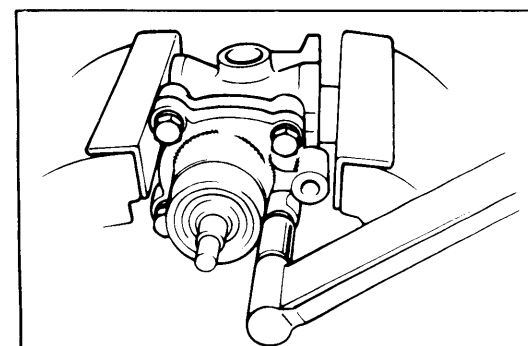
**12. TIGHTEN FOUR HOUSING BOLTS**

- (a) Clamp the rear housing in a vise.

**CAUTION:** Do not tight the vise too tight.

- (b) Tighten the four housing bolts evenly in 3 or 4 passes.

**Torque:** 470 kg-cm (34 ft-lb, 46 N·m)

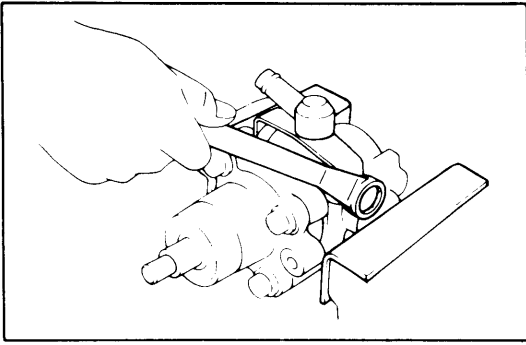
**13. INSTALL UNION TO REAR HOUSING**

Insert and tighten the union.

**Torque: 130 kg-cm (9 ft-lb, 13 N·m)**

**14. INSTALL AIR CONTROL VALVE TO REAR HOUSING**

Install and tighten the air control valve.

**Torque: 370 kg-cm (27 ft-lb, 36 N·m)**

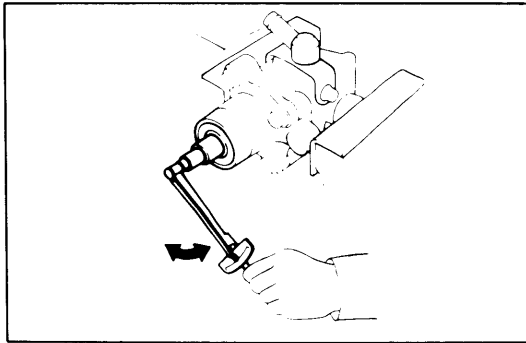
**15. CHECK ROTOR SHAFT ROTATION CONDITION**

- (a) Check that the rotor shaft rotates smoothly without abnormal noise.
- (b) Provisionally install the pulley nut and check the rotation torque.

**Rotation torque: Less than 2.8 kg-cm  
(2.4 in.-lb, 0.3 N·m)**

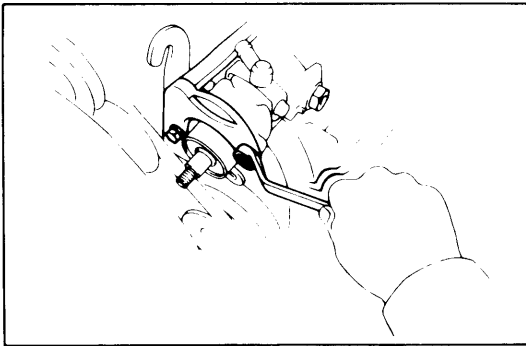

## INSTALLATION OF POWER STEERING PUMP

(See page SR-29)

### 1. INSTALL POWER STEERING PUMP

Place the PS pump in position and torque the mount bolts.

**Torque: 400 kg-cm (29 ft-lb, 39 N·m)**

### 2. INSTALL PULLEY AND DRIVE BELT

(a) Install the woodruff key, pulley and set nut.

(b) Install the drive belt.

(c) Turn the adjusting bolt until the belt tension is at specified value.

(d) Using a belt tension gauge, check the drive belt tension.

Belt tension gauge:

Nippondenso BTG-20 (95506-00020) or

Borroughs No. BT-33-73F

**Drive belt tension: New belt 125 ± 25 lb  
Used belt 80 ± 20 lb**

If necessary, adjust the belt tension.

NOTE:

- "New belt" refers to a belt which has been used less than 5 minutes on a running engine.
- "Used belt" refers to a belt which has been used on a running engine for 5 minutes or more.

(e) Tighten the idler pulley nut.

(f) Push down on the drive belt to hold the pulley in place and torque the pulley set nut.

**Torque: 440 kg-cm (32 ft-lb, 43 N·m)**

### 3. CONNECT PRESSURE TUBE TO POWER STEERING PUMP

Using SST, torque the flare nut.

SST 09631-22020

**Torque: 450 kg-cm (33 ft-lb, 44 N·m)**

### 4. CONNECT RETURN HOSE TO RESERVOIR TANK

### 5. CONNECT AIR HOSES TO AIR CONTROL VALVE

### 6. FILL RESERVOIR WITH FLUID

Fluid: ATF DEXRON® or DEXRON® II

### 7. BLEED POWER STEERING

### 8. CHECK FOR FLUID LEAKS

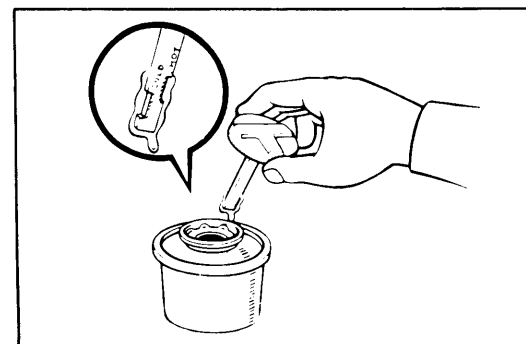
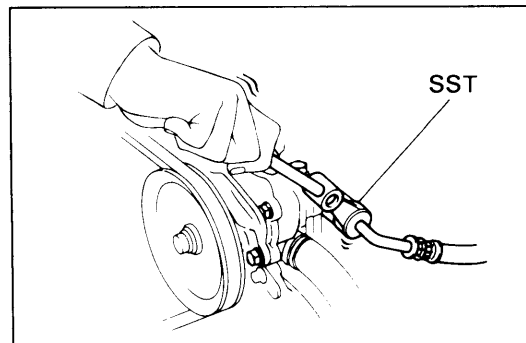
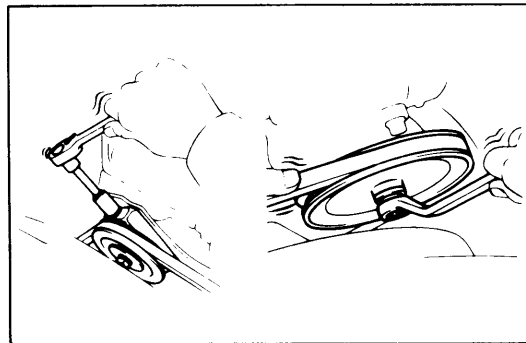
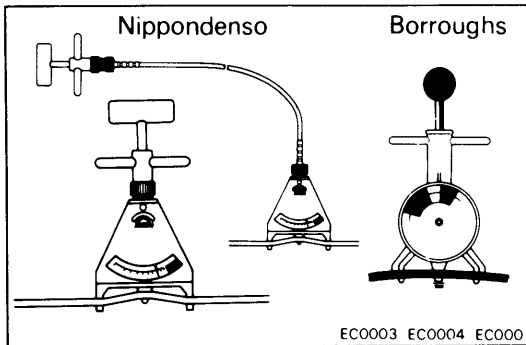

# Steering Gear Housing

## REMOVAL OF GEAR HOUSING (2WD)

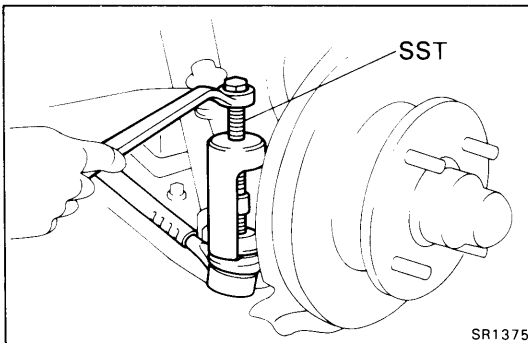
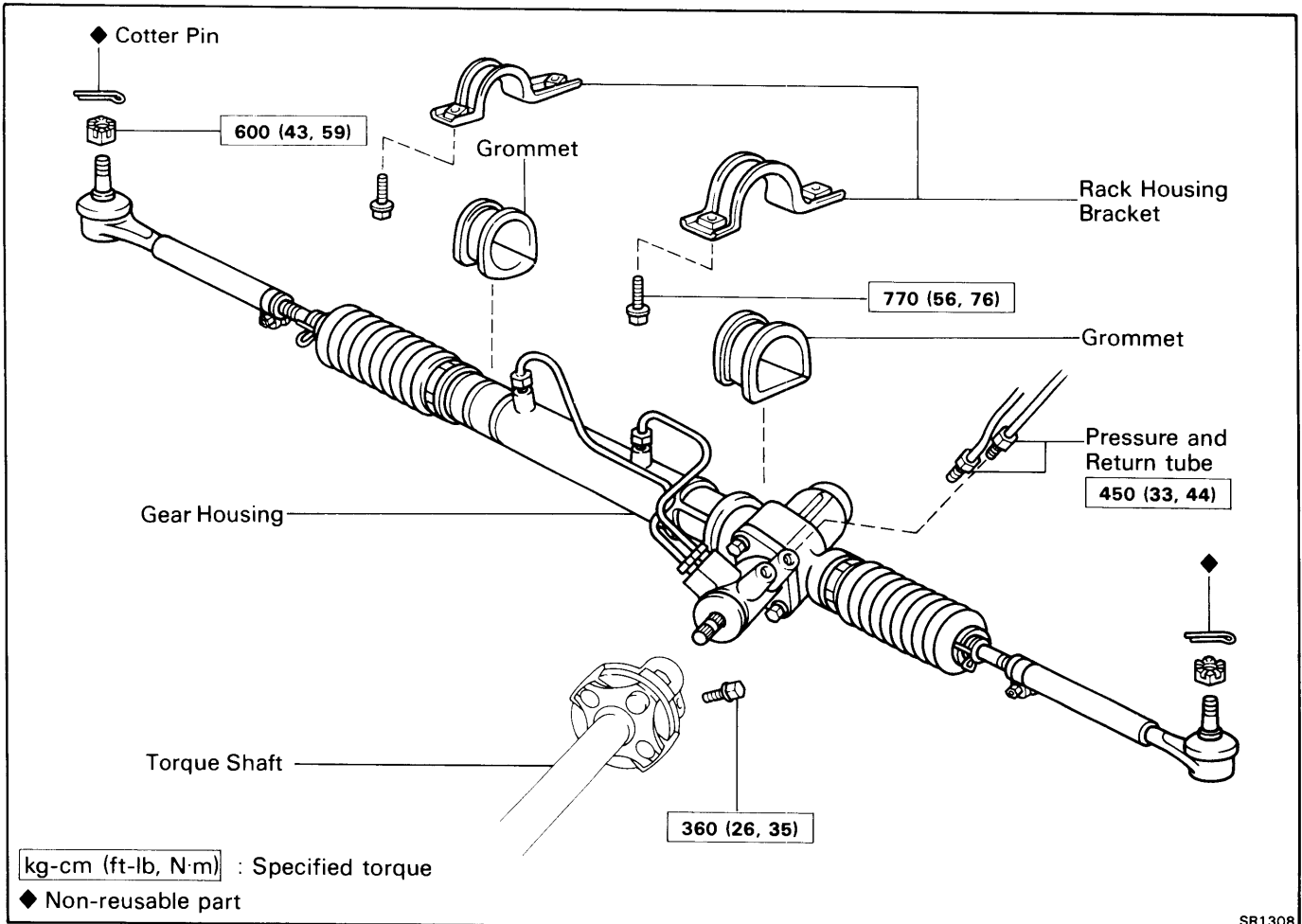

### 1. REMOVE FRONT WHEEL

### 2. DISCONNECT TIE ROD FROM KNUCKLE ARM

- Remove the cotter pin and set nut.
- Using SST, disconnect the tie rod from the knuckle arm.

SST 09610-20012

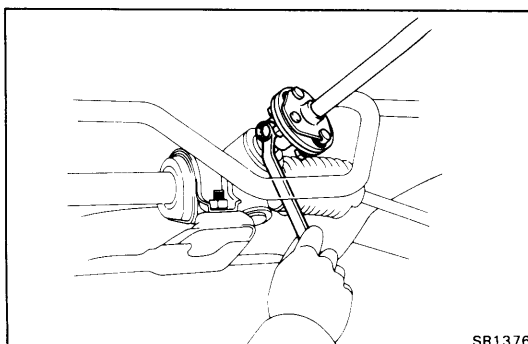

### 3. DISCONNECT TORQUE SHAFT FROM GEAR HOUSING

- Place matchmarks on the torque shaft and pinion shaft.
- Remove the set bolt.

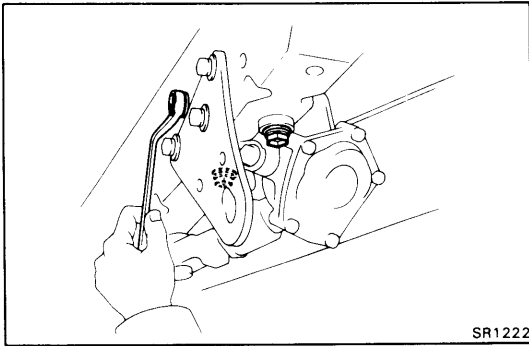

- (c) Remove the three bolts and bevel gear.
- (d) Disconnect the torque shaft from the pinion shaft.

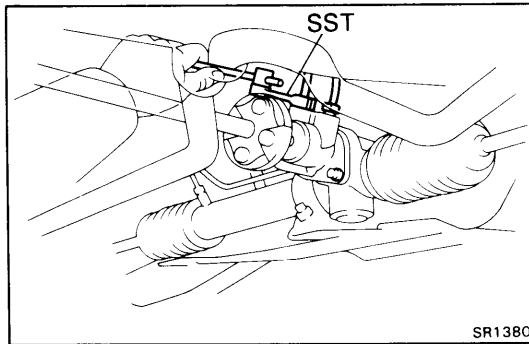

- 4. DISCONNECT PRESSURE AND RETURN TUBES**  
Using SST, disconnect the pressure and return tube.  
SST 09631-22020

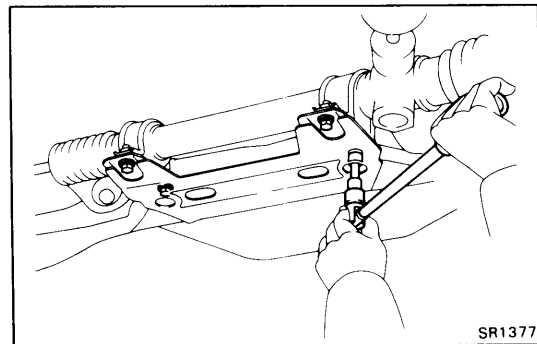

- 5. REMOVE GEAR HOUSING**  
Remove the four bolts and gear housing.

## REMOVAL OF GEAR HOUSING (4WD)

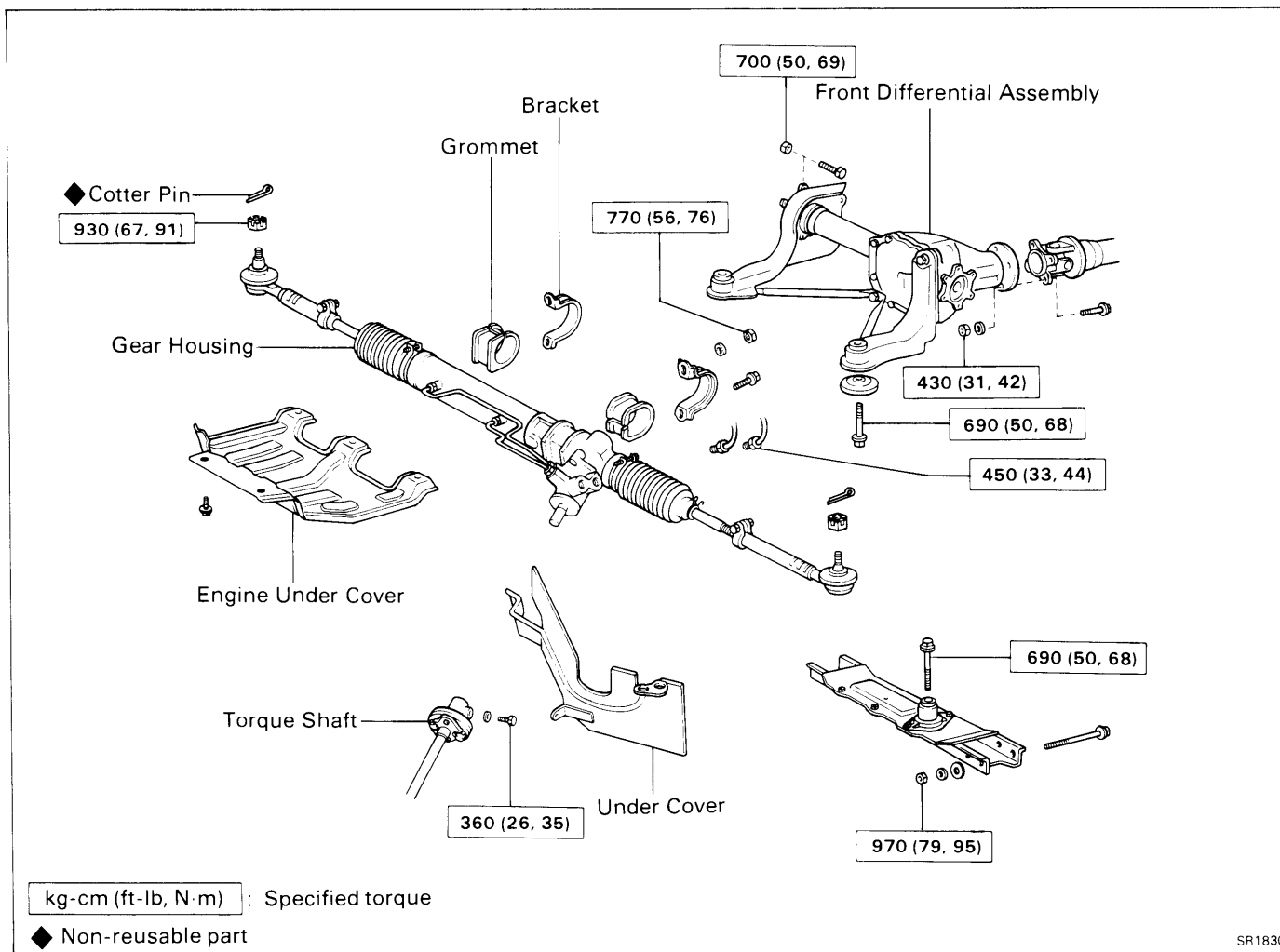

**1. REMOVE FRONT DIFFERENTIAL ASSEMBLY**  
(See page FA-73)

**2. DISCONNECT TIE ROD END FROM KNUCKLE ARM**

- (a) Remove the cotter pin and set nut.
- (b) Using SST, disconnect the tie rod end from the knuckle arm.

SST 09610-20012

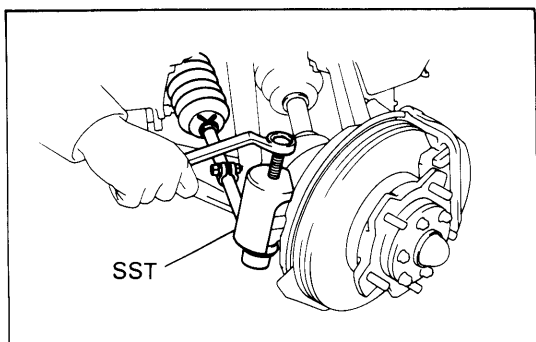

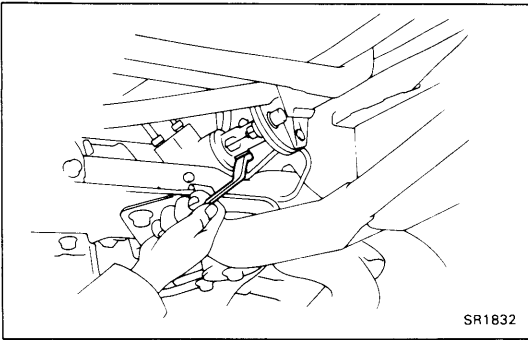

### 3. DISCONNECT TORQUE SHAFT FROM GEAR HOUSING

- (a) Remove the two bolts and under cover.
- (b) Place the matchmarks on the torque shaft and pinion shaft.
- (c) Remove the set bolt.

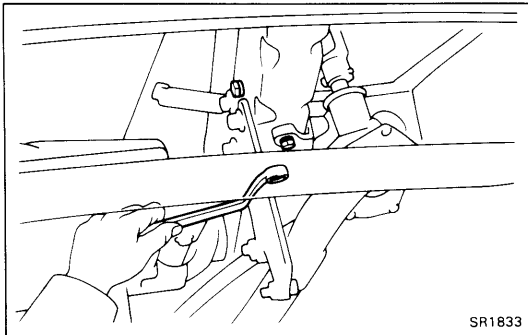

- (d) Remove the three bolts and bevel gear.
- (e) Disconnect the torque shaft from the pinion shaft.

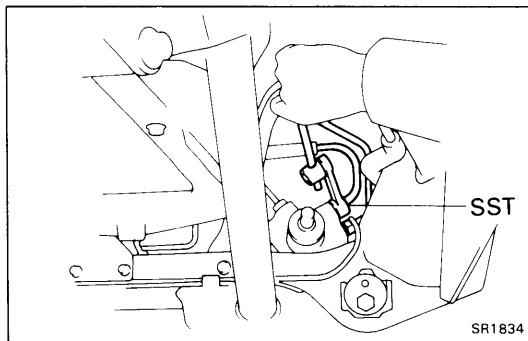

### 4. DISCONNECT PRESSURE AND RETURN TUBES

Using SST, disconnect the pressure and return tubes from the gear housing.

SST 09631-22020

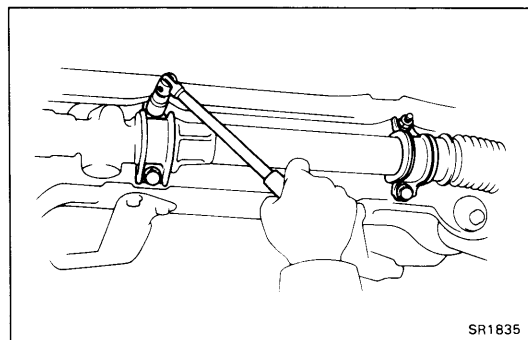

### 5. REMOVE GEAR HOUSING

Remove the two bolts, two nuts and gear housing.

COMPONENTS

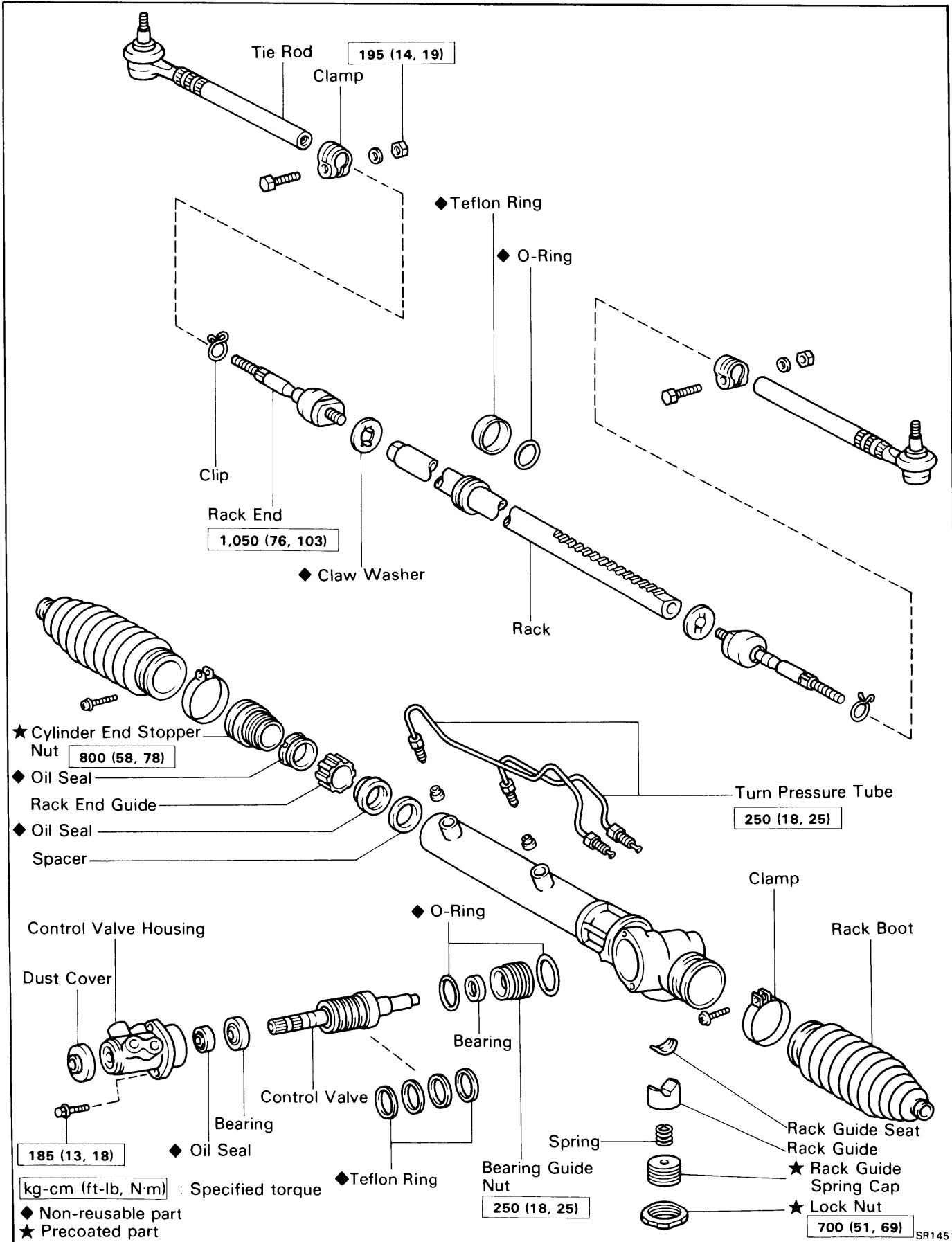

kg-cm (ft-lb, N-m) : Specified torque

◆ Non-reusable part

★ Precoated part

SR1451

cardiagn.com

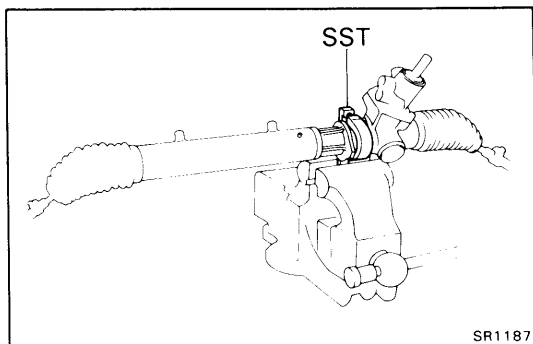

## DISASSEMBLY OF STEERING GEAR HOUSING

(See page SR-42)

### 1. CLAMP GEAR HOUSING IN VISE

Using SST, secure the steering gear in a vise.  
SST 09612-00012

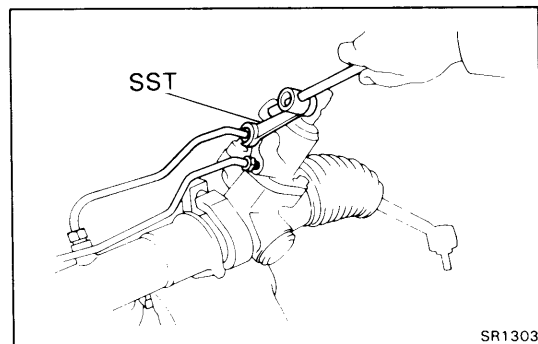

### 2. REMOVE RIGHT AND LEFT TURN PRESSURE TUBES

Using SST, remove the pressure tubes.  
SST 09633-00020

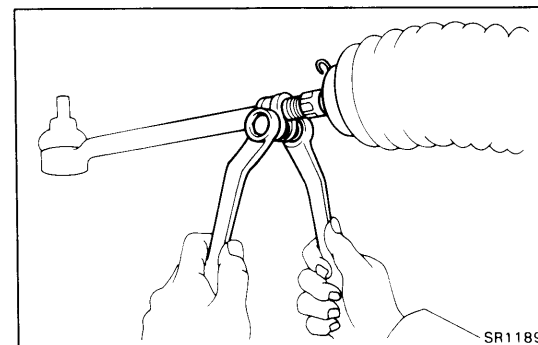

### 3. REMOVE TIE RODS

- Place matchmarks on the tie rod and rack end.
- Loosen the clamp bolt and remove the tie rod from the rack end.

### 4. REMOVE CLIPS, CLAMPS AND RACK BOOTS

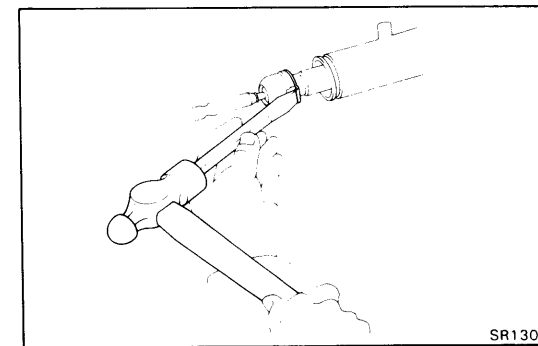

### 5. REMOVE RACK ENDS AND CLAW WASHERS

- Unstake the claw washer.

**CAUTION:** Avoid any impact to the rack.

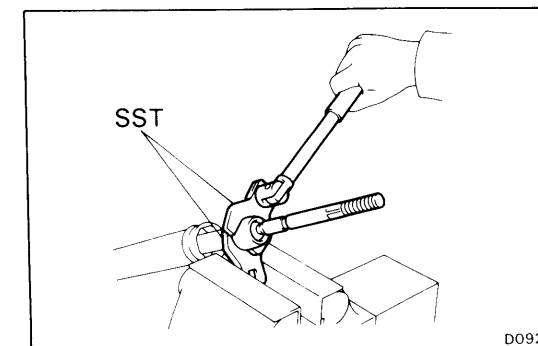

- Using SST, remove the rack ends.  
SST 09612-24013 (09617-24010, 09617-24030)
- NOTE:** Mark the left and right rack ends.
- Remove the claw washer.

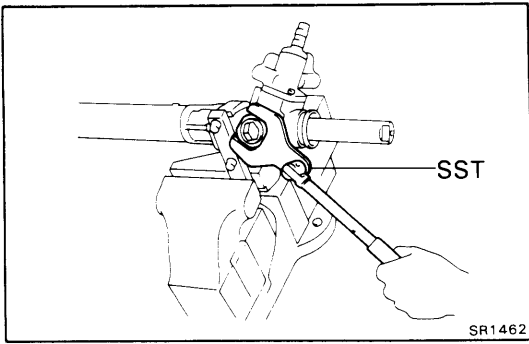
**6. REMOVE RACK GUIDE SPRING CAP LOCK NUT**

Using SST, remove the rack guide spring cap lock nut.  
SST 09612-24013 (09617-24020)

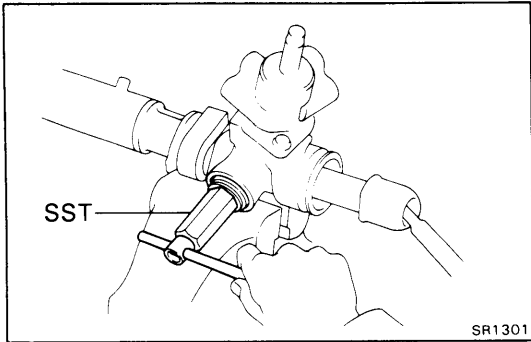
**7. REMOVE RACK GUIDE SPRING CAP**

Using SST, remove the rack guide spring cap.  
SST 09612-24013 (09612-10022)

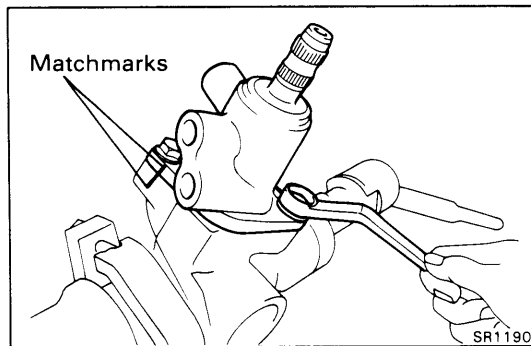
**8. REMOVE RACK GUIDE, SPRING AND SEAT****9. REMOVE CONTROL VALVE AND HOUSING**

- Place matchmarks on the valve housing and rack housing.
- Remove the two bolts.
- Pull out the valve with the valve housing.
- Remove the O-ring.

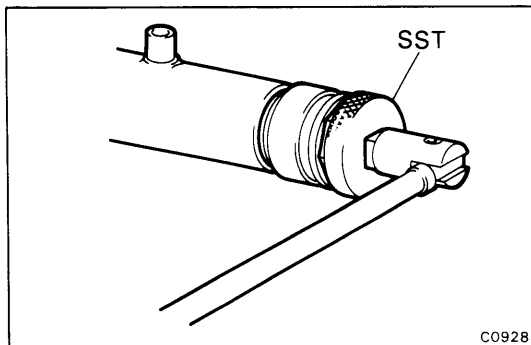
**10. REMOVE CYLINDER END STOPPER NUT**

Using SST, remove the stopper nut.  
SST 09631-20120

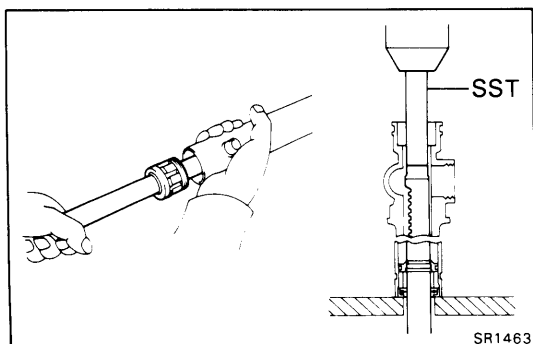
**11. REMOVE OIL SEAL, RACK END GUIDE AND STEERING RACK**

Using a press and SST, remove the oil seal, rack end guide and rack.

SST 09612-24013 (09612-10061)

**CAUTION:** Be careful not to damage the inside of the cylinder tube.

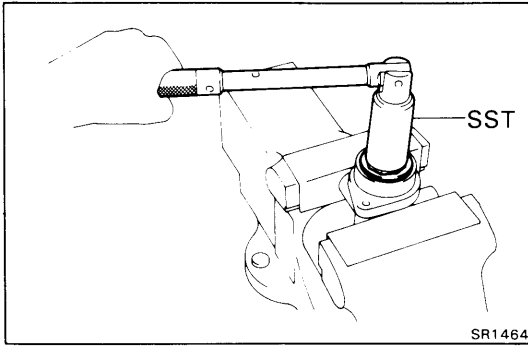
**12. REMOVE CONTROL VALVE**

- (a) Remove the dust cover.
- (b) Using SST, loosen the bearing guide nut.  
SST 09631-20060

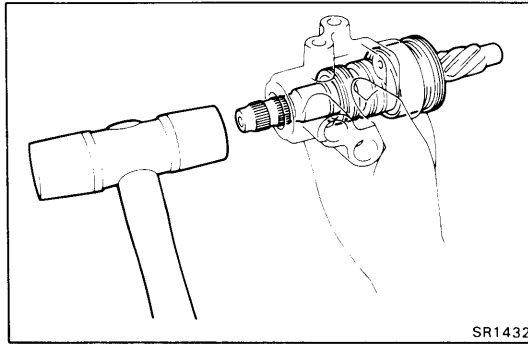

- (c) Using a plastic hammer, tap out the control valve with the bearing guide nut.
- (d) Remove the O-ring.

## INSPECTION AND REPAIR OF GEAR HOUSING COMPONENTS

### 1. INSPECT RACK

- Check the rack for runout and for teeth wear or damage.
- Check the back surface for wear or damage.

If faulty, replace it.

**Maximum runout: 0.3 mm (0.012 in.)**

### 2. INSPECT NEEDLE ROLLER BEARING

- Check for wear or damage.
- If necessary, replace the cylinder housing assembly.

### 3. IF NECESSARY, REPLACE CONTROL VALVE BEARING AND OIL SEAL

- Using SST, press out the oil seal and bearing from the control valve housing.

SST 09630-24013 (09620-24010)  
09631-12020

- Coat the oil seal lip with power steering fluid.

- Using SST, press a new oil seal into the control valve housing.

SST 09630-24013 (09620-24020)  
09631-12020

- Using SST, press a new bearing into the control valve housing.

SST 09630-24013 (09620-24030)  
09631-12020

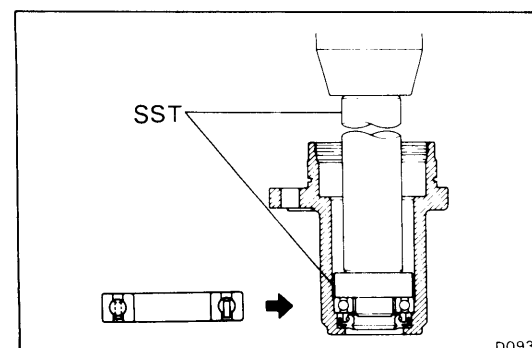
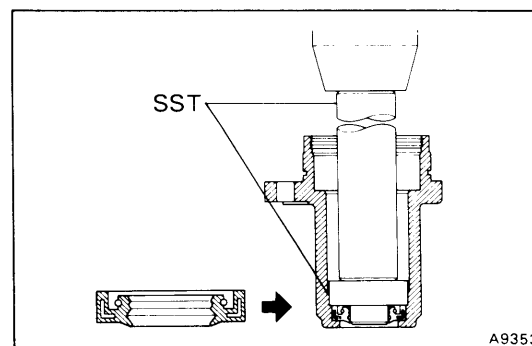
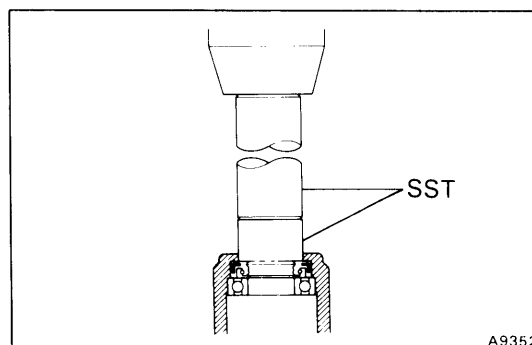
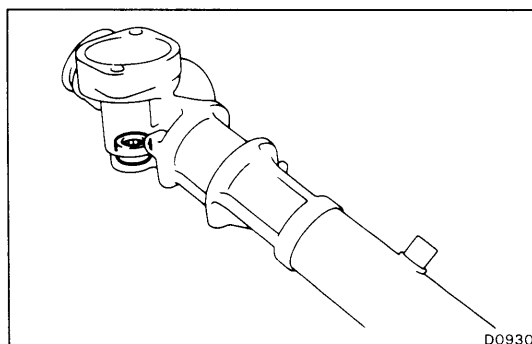
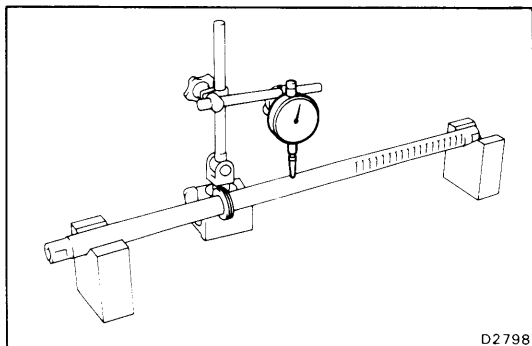

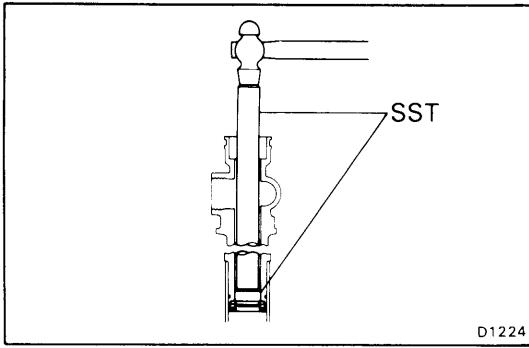

#### 4. IF NECESSARY, REPLACE CYLINDER HOUSING OIL SEAL

- (a) Using SST, remove the oil seal with the spacer.
- SST 09630-00011 (09631-00080)  
09631-12020
- (b) Coat the oil seal lip with power steering fluid.

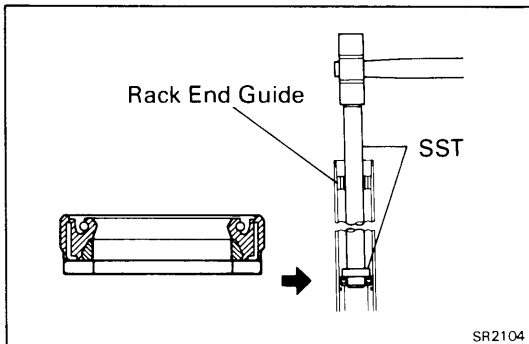

- (c) Install the oil seal and spacer to SST, and insert it to the rack housing.

SST 09630-24013 (09631-24070)  
09631-12020

- (d) To prevent the spacer and oil seal from being installed slantwise, install the rack end guide to the rack housing.
- (e) Tap SST with a plastic hammer.

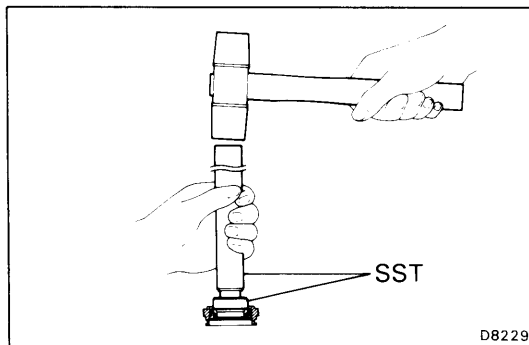

#### 5. IF NECESSARY, REPLACE BEARING GUIDE NUT OIL SEAL

- (a) Using SST, press out the oil seal.
- SST 09630-24013 (09620-24020)  
09631-12020
- (b) Coat the oil seal lip with power steering fluid.

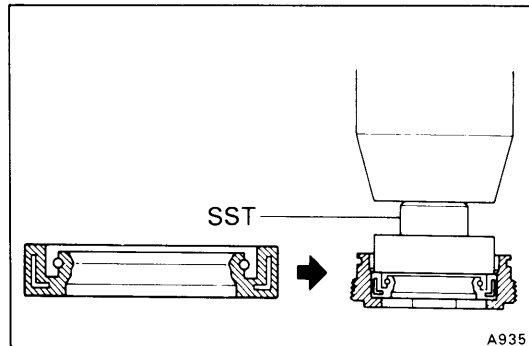

- (c) Using SST, press a new oil seal into the guide nut.
- SST 09631-20040

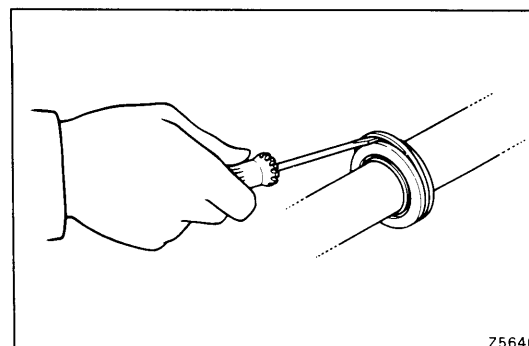

#### 6. IF NECESSARY, REPLACE TEFLON RING AND O-RING

- (a) Using a screwdriver, remove the teflon ring and O-ring.

**CAUTION:** Be careful not to damage the steering rack.

- (b) Install a new O-ring.
- (c) Expand a new teflon ring with your fingers.

**CAUTION:** Be careful not to over-expand the teflon ring.

- (d) Install a new teflon ring.

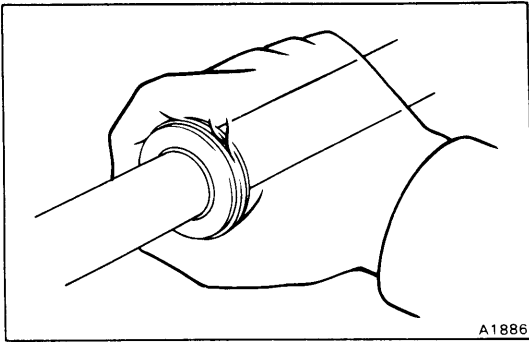

- (e) Coat the teflon ring with power steering fluid and snug it down with your fingers.

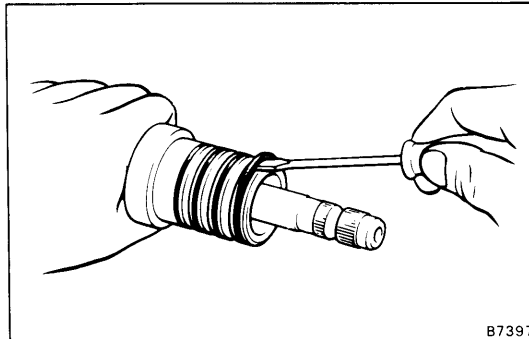

## 7. IF NECESSARY, REPLACE CONTROL VALVE TEFLON RING

- (a) Using a screwdriver, remove the teflon ring.

**CAUTION:** Be careful not to damage the control valve.

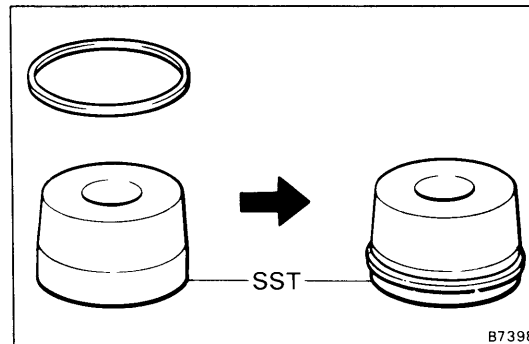

- (b) Install a new teflon ring to SST and expand it.  
SST 09631-20070

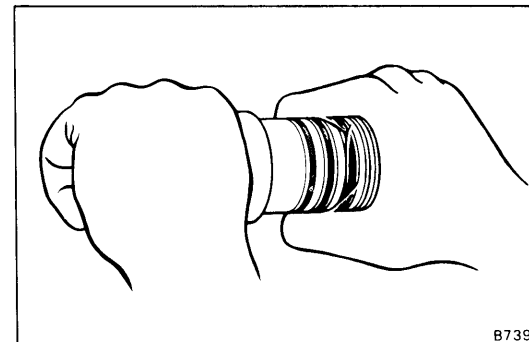

- (c) Install the expanded teflon rings to the control valve and snug it down with your fingers.

**CAUTION:** Be careful not to damage the teflon rings.

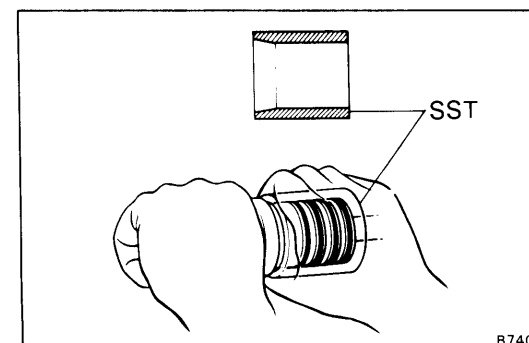

- (d) Coat the teflon ring with power steering fluid, and carefully slide the tapered end of SST over the teflon ring to seat the ring.

SST 09631-20081

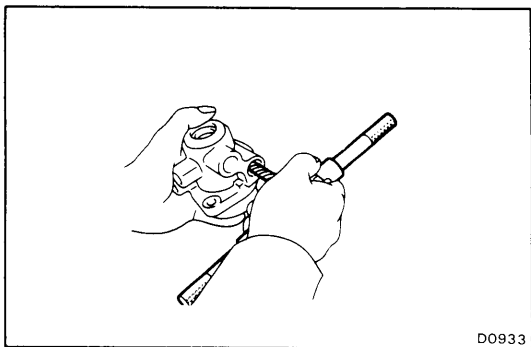
**8. IF NECESSARY, REPLACE UNION SEAT**

(a) Using a screw extractor, remove the union seat.

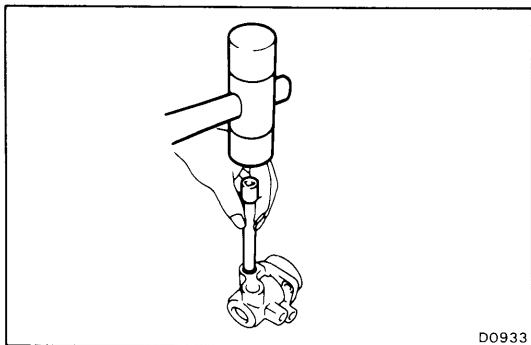

(b) Using a plastic hammer and extension bar, tap in a new union seat.

**ASSEMBLY OF GEAR HOUSING**

(See page SR-42)

1. COAT POWER STEERING FLUID OR GREASE ON FOLLOWING PARTS:

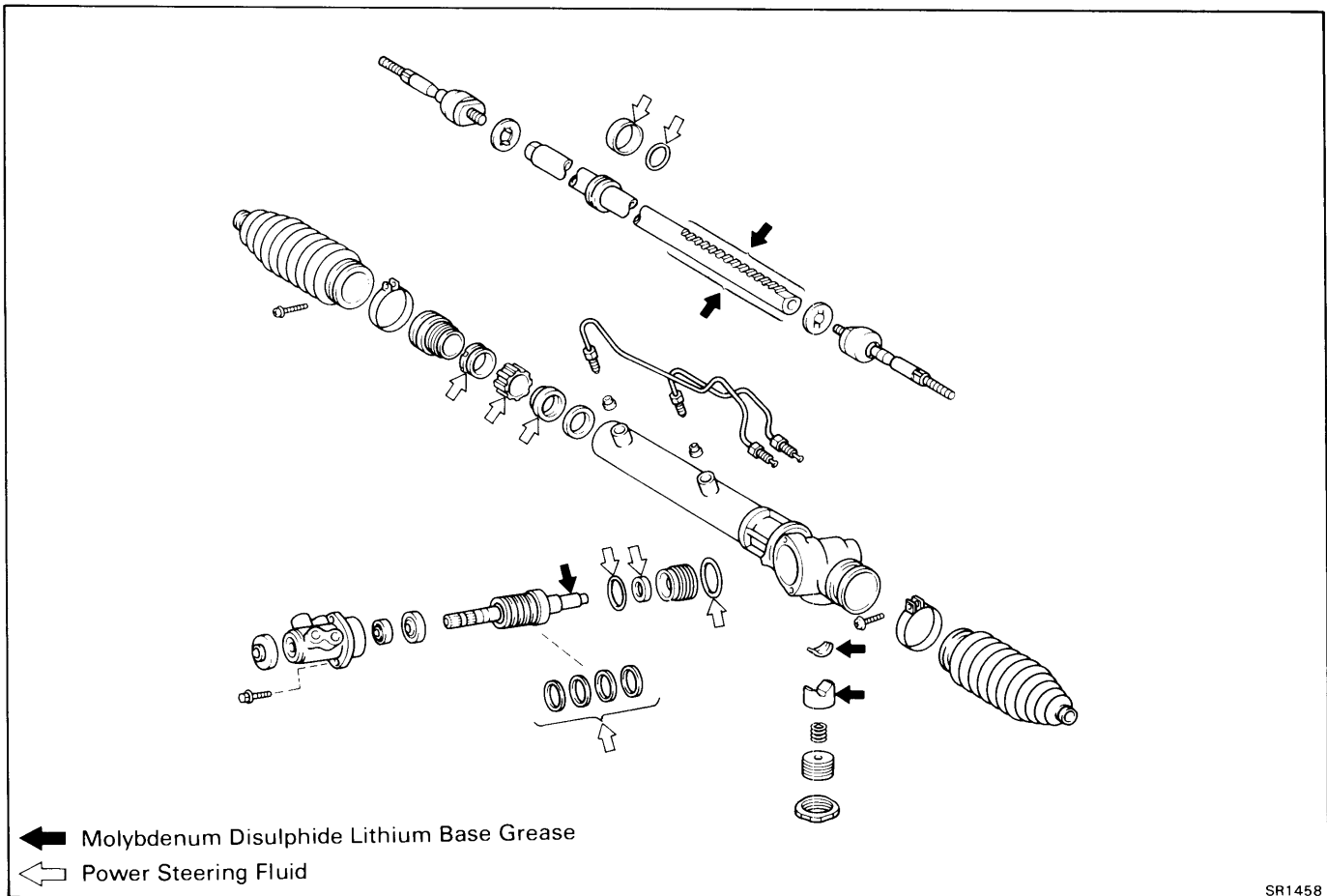

SR1458

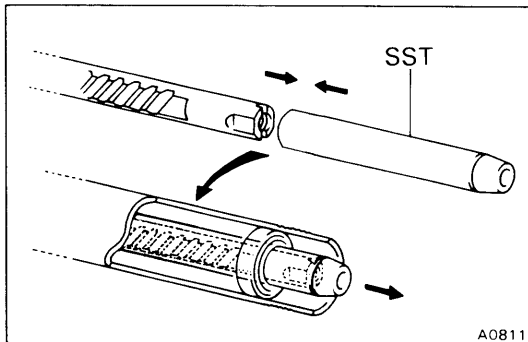
**2. INSTALL RACK**

- (a) Install SST to the rack.

SST 09631-20110 (For 2WD)  
 09631-20111 (For 4WD)

NOTE: If necessary, scrape the burrs off the rack teeth end and burnish.

- (b) Coat SST with power steering fluid.
- (c) Insert the rack into the cylinder.
- (d) Remove SST.

**3. INSTALL RACK END GUIDE**

Install the rack end guide to the rack and slide it into the housing.

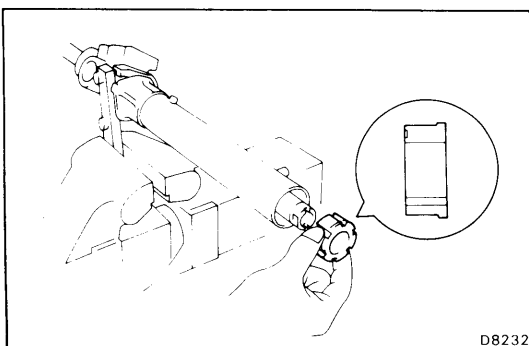

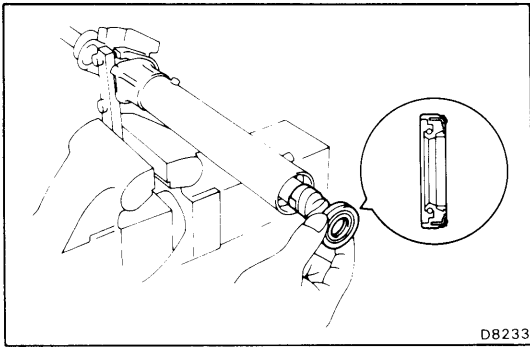

#### 4. INSTALL CYLINDER END STOPPER, OIL SEAL AND SPACER

- (a) Coat the oil seal with power steering fluid.
- (b) Clean the end stopper and apply liquid sealer to the two or three threads of the end stopper.

**Sealant: Part No. 08833-00080, THREE BOND 1344, LOCTITE 242 or equivalent**

- (c) To prevent oil seal lip damage, wind vinyl tape on the steering rack end, and apply power steering fluid.
- (d) Install the oil seal by pushing into the cylinder in the direction shown in drawing, without tilting.
- (e) Using SST, torque the end stopper.

SST 09631-20120

**Torque: 800 kg-cm (58 ft-lb, 78 N·m)**

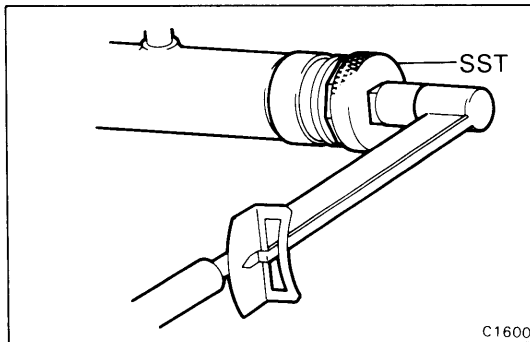

- (f) Using a pin punch and hammer, stake the housing and stopper.

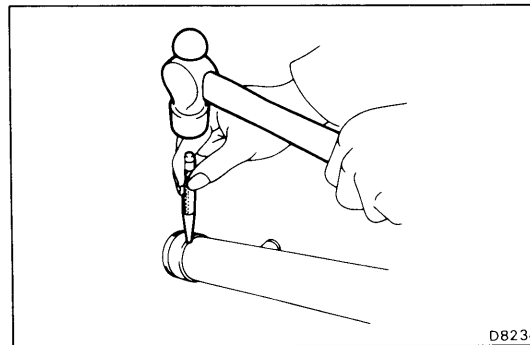

#### 5. INSTALL CONTROL VALVE INTO HOUSING

- (a) Install a new O-ring to the control valve.
- (b) Coat the teflon ring and O-ring with power steering fluid.
- (c) Push the control valve into the housing.

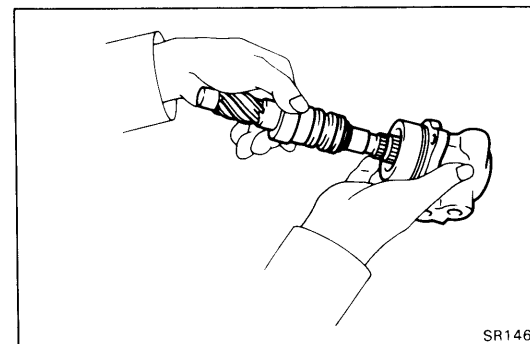

- (d) Using SST, install the bearing guide nut.
- SST 09631-20060

**Torque: 250 kg-cm (18 ft-lb, 25 N·m)**

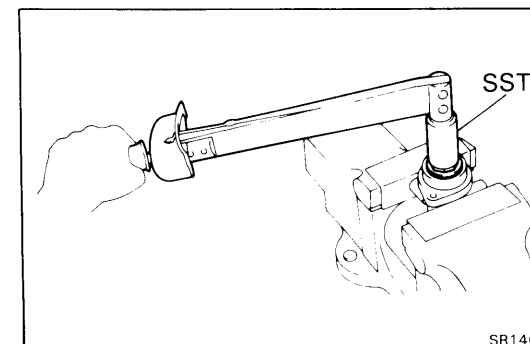

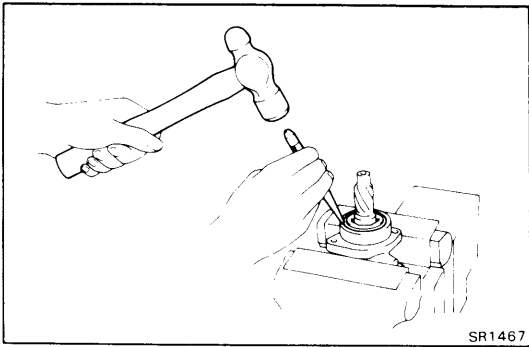

- (e) Using a hammer and chisel, stake the nut.
- (f) Install the dust cover.

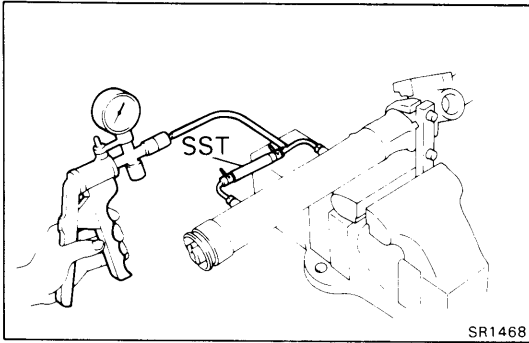

#### 6. AIR TIGHTNESS TEST

- (a) Install SST to the union of the cylinder housing.  
SST 09631-12070
- (b) Apply 400 mmHg (15.75 in.Hg, 53.3 kPa) of vacuum for about 30 seconds.
- (b) Check that there is no change in the vacuum.

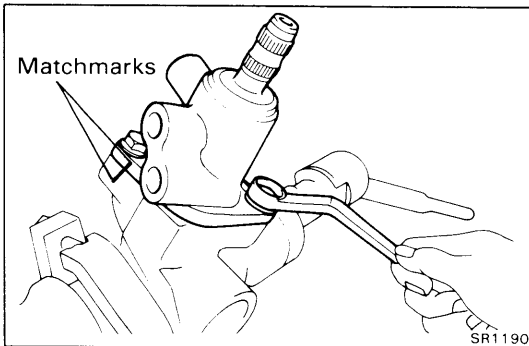

#### 7. INSTALL CONTROL VALVE

- (a) Install a new O-ring to the valve.
- (b) Align the marks on the valve housing and rack housing.
- (c) Torque the two bolts.

**Torque: 185 kg-cm (13 ft-lb, 18 N·m)**

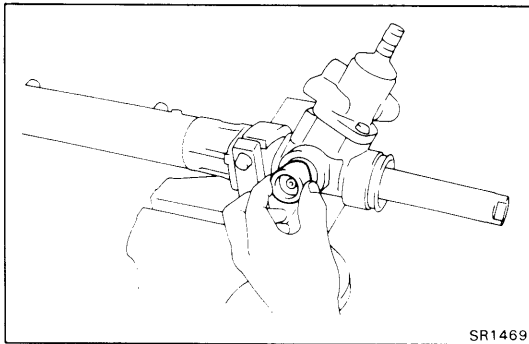

#### 8. INSTALL RACK GUIDE, SEAT AND RACK GUIDE SPRING

#### 9. INSTALL RACK GUIDE SPRING CAP

Apply liquid sealer to the threads of the spring cap.

**Sealant: Part No. 08833-00080, THREE BOND 1344, LOCTITE 242 or equivalent**

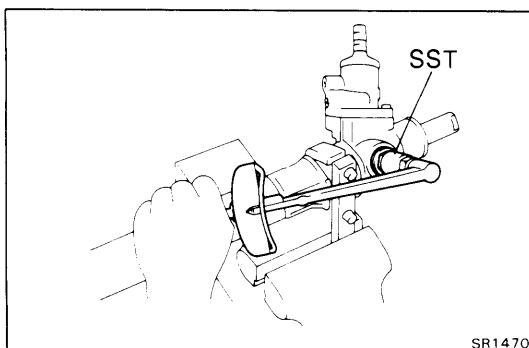

#### 10. ADJUST TOTAL PRELOAD

- (a) Using SST, torque the rack guide spring cap.  
SST 09612-24013 (09612-10022)
- Torque: 250 kg-cm (18 ft-lb, 25 N·m)**

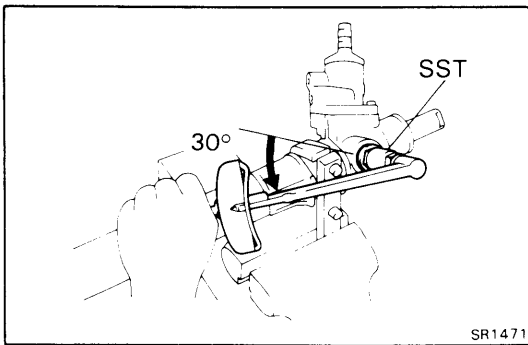

- (b) Using SST, return the rack guide spring cap 30°.  
SST 09612-24013 (09612-10022)
- (c) Turn the control valve shaft right and left one or two times.
- (d) Loosen the spring cap to when the rack guide compression spring is not functioning.

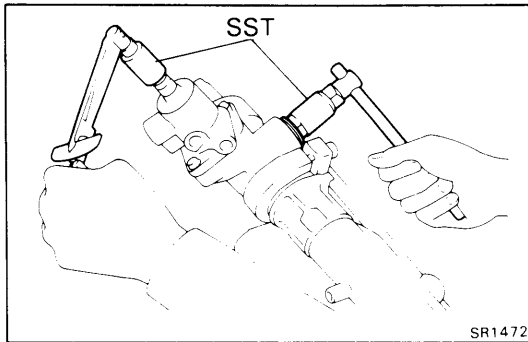

- (e) Using SST and a torque meter, tighten the rack guide spring cap until the preload is within specification.  
SST 09612-24013 (09612-10022)  
09616-00010
- Preload (turning): 9 – 13 kg-cm  
(7.8 – 11.3 in.-lb, 0.9 – 1.3 N·m)**

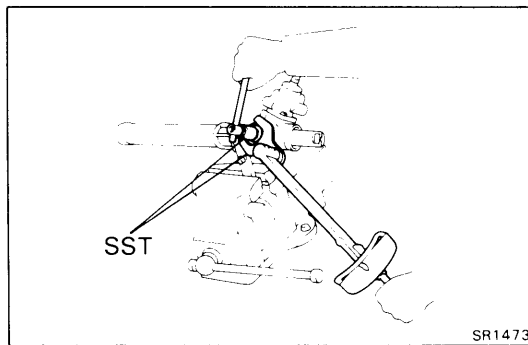

#### 11. INSTALL RACK GUIDE SPRING CAP LOCK NUT

- (a) Apply liquid sealer to the screws of the spring cap lock nut.

**Sealant: Part No. 08833-00080, THREE BOND 1344, LOCTITE 242 or equivalent**

- (b) Using SST, install and torque the lock nut.  
SST 09612-24013 (09612-10022, 09617-24020)

**Torque: 700 kg-cm (51 ft-lb, 69 N·m)**

- (c) Recheck the total preload.
- (d) Using a pin punch and hammer, stake the lock nut and cap.

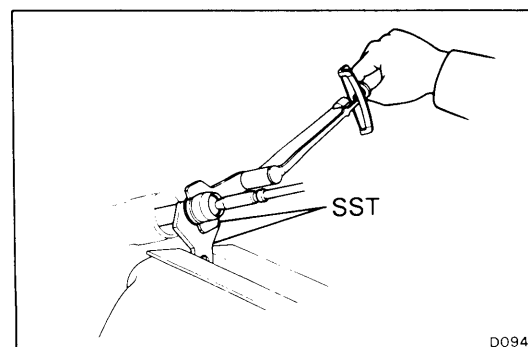
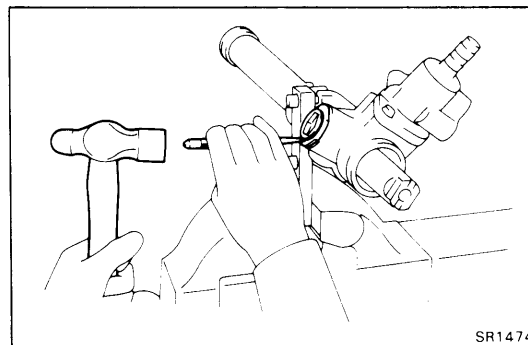

#### 12. INSTALL CLAW WASHERS AND RACK ENDS

- (a) Install a new claw washer.

**NOTE:** Align the claw of the claw washer with the rack groove.

- (b) Tighten the rack end and torque it with SST.  
SST 09612-24013 (09617-24010, 09617-24030)

**Torque: 1,050 kg-cm (76 ft-lb, 103 N·m)**

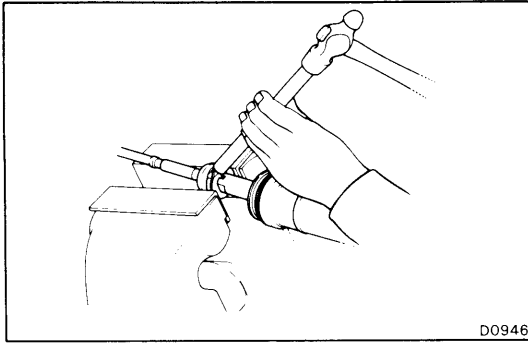

- (c) Using a hammer and brass bar, stake the claw washer.

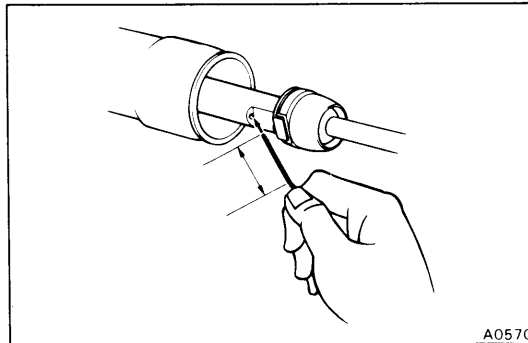

### 13. INSTALL RACK BOOTS, CLAMPS AND CLIPS

- (a) Insure that the tube hole is not clogged with grease.

NOTE: If the tube hole is clogged, the pressure inside the boot will change after it is assembled and the handle turned.

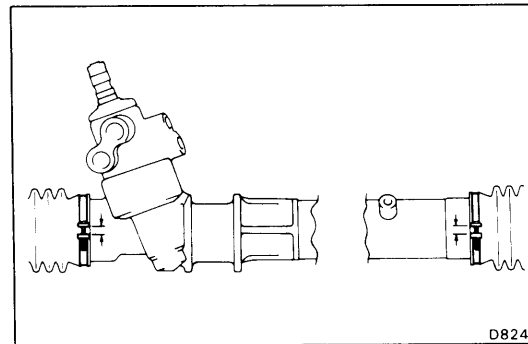

- (b) Install the boots.

NOTE: Be careful not to damage or twist the boots.

- (c) Install the clamps.

- (d) Install the clips.

NOTE: Face the open ends outward to avoid damage to the boots.

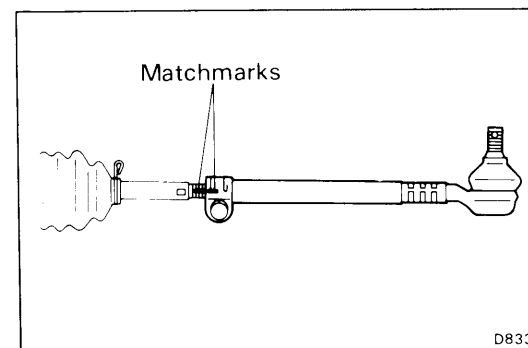

### 14. INSTALL TIE RODS

- (a) Screw the tie rods onto the rack ends until the matchmarks are aligned.

- (b) After adjusting toe-in, torque the clamp bolts.

**Torque: 195 kg-cm (14 ft-lb, 19 N·m)**

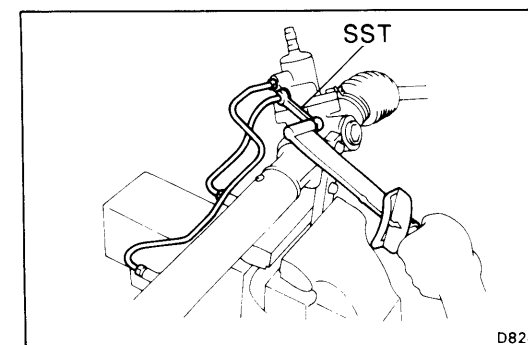

### 15. INSTALL RIGHT AND LEFT TURN PRESSURE TUBES

Using SST, tighten the nuts and torque them.

NOTE: First torque the nuts of the cylinder housing.

SST 09633-00020

**Torque: 250 kg-cm (18 ft-lb, 25 N·m)**

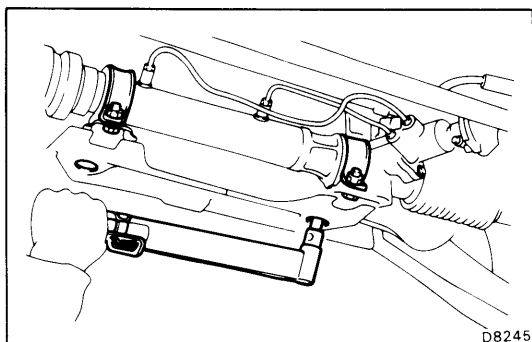

## INSTALLATION GEAR HOUSING (2WD)

(See page SR-38)

### 1. INSTALL GEAR HOUSING

Install the gear housing with the four bolts to the body and torque the four bolts.

**Torque: 770 kg-cm (56 ft-lb, 76 N·m)**

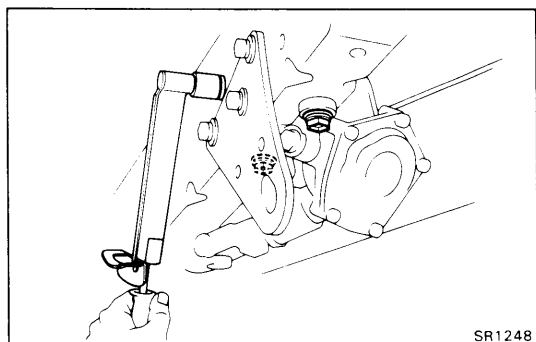

### 2. CONNECT TORQUE SHAFT TO GEAR HOUSING

(a) Align the matchmarks on the torque shaft and pinion shaft.

(b) Install the bevel gear with the three bolts and torque the three bolts.

**Torque: 400 kg-cm (29 ft-lb, 39 N·m)**

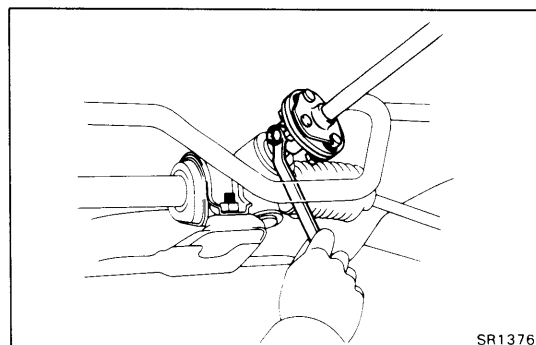

(c) Torque the coupling bolts.

**Torque: 360 kg-cm (26 ft-lb, 35 N·m)**

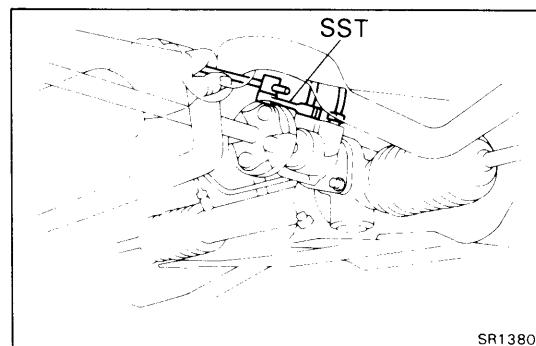

### 3. CONNECT RETURN LINE AND PRESSURE LINES

Using SST, connect the return and pressure tube.

SST 09631-22020

**Torque: 450 kg-cm (33 ft-lb, 44 N·m)**

### 4. CONNECT TIE ROD TO KNUCKLE ARM

(a) Install the tie rod to the knuckle arm and torque the mount nut.

**Torque: 600 kg-cm (43 ft-lb, 59 N·m)**

(b) Install a new cotter pin.

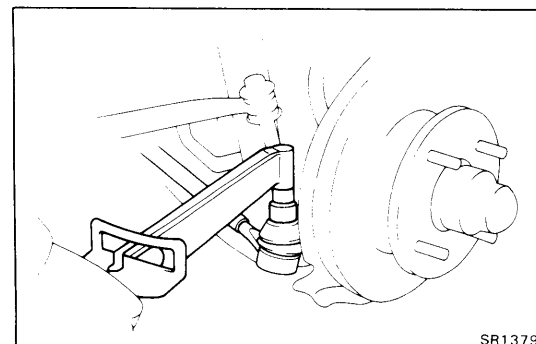

### 5. INSTALL WHEEL

### 6. FILL RESERVOIR TANK WITH FLUID

**Fluid: ATF DEXRON® or DEXRON® II**

### 7. BLEED POWER STEERING SYSTEM (See page SR-27)

### 8. CHECK FOR FLUID LEAKS

### 9. CHECK TOE-IN (See page FA-6)

### 10. CHECK STEERING WHEEL CENTER POINT

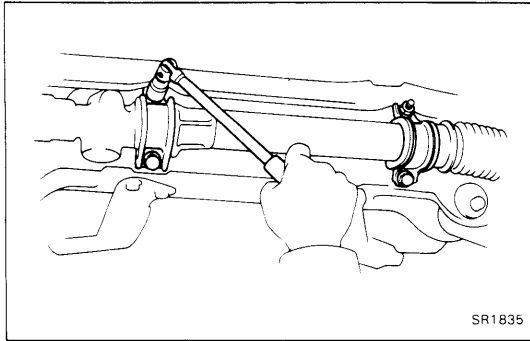

## INSTALLATION OF GEAR HOUSING (4WD)

(See page SR-40)

### 1. INSTALL GEAR HOUSING

- (a) Install the two grommets to the gear housing.
- (b) Install the gear housing with the brackets, and torque the two bolts and two nuts.

**Torque: 770 kg-cm (56 ft-lb, 76 N·m)**

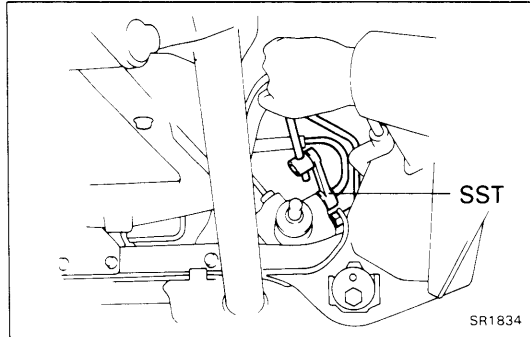

### 2. CONNECT PRESSURE AND RETURN TUBES

Using SST, connect the pressure and return tubes to the gear housing.

SST 09631-22020

**Torque: 450 kg-cm (33 ft-lb, 44 N·m)**

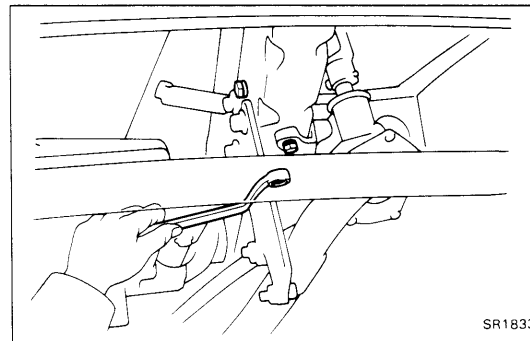

### 3. CONNECT TORQUE SHAFT TO GEAR HOUSING

- (a) Align the matchmarks on the torque shaft and pinion shaft.
- (b) Install the bevel gear with the three bolts and torque the bolts.

**Torque: 400 kg-cm (29 ft-lb, 39 N·m)**

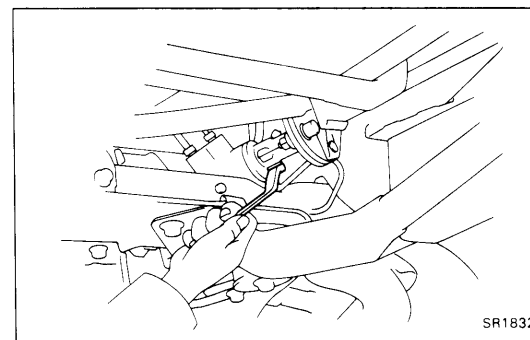

- (c) Torque the set bolt.

**Torque: 360 kg-cm (26 ft-lb, 35 N·m)**

- (d) Install the under cover with the two bolts.

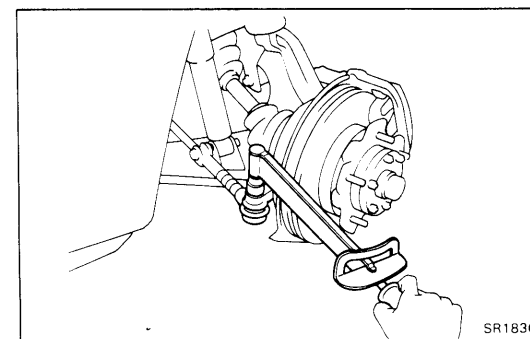

### 4. CONNECT TIE ROD END TO KNUCKLE ARM

- (a) Install the tie rod end to the knuckle arm and torque the mount nut.

**Torque: 930 kg-cm (67 ft-lb, 91 N·m)**

- (b) Install a new cotter pin.

5. **INSTALL FRONT DIFFERENTIAL ASSEMBLY**  
(See page FA-96)
6. **FILL RESERVOIR TANK WITH FLUID**  
Fluid: ATF DEXRON® or DEXRON® II
7. **BLEED POWER STEERING SYSTEM**
8. **CHECK FOR FLUID LEAKS**
9. **CHECK TOE-IN**  
(See page FA-34)
10. **CHECT STEERING WHEEL CENTER POINT**

# STEERING BEVEL GEAR HOUSING

## REMOVAL OF BEVEL GEAR HOUSING

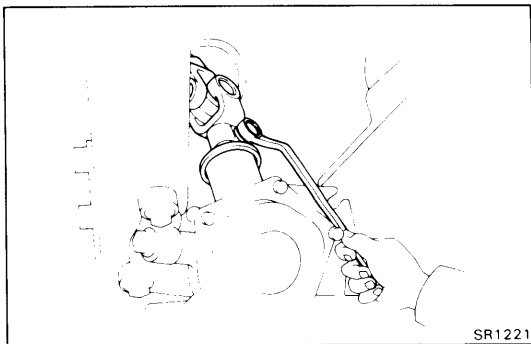
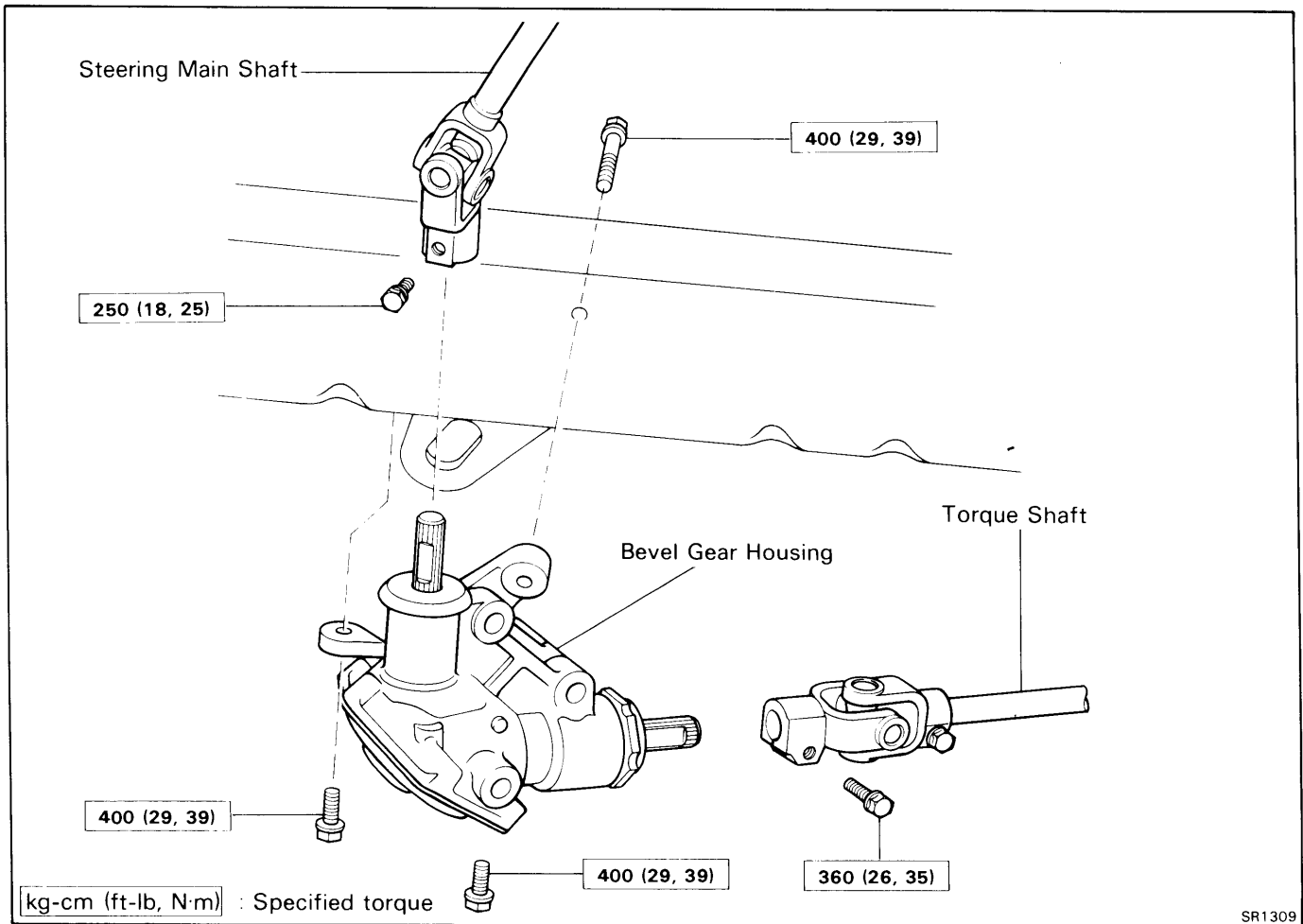

**1. REMOVE TWO UNIVERSAL JOINT BOLTS**

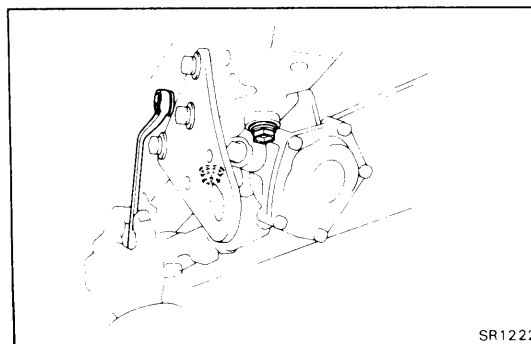

**2. REMOVE BEVEL GEAR HOUSING WITH BRACKET**

- (a) Remove the three bolts.
- (b) Remove the bevel gear with bracket.

COMPONENTS

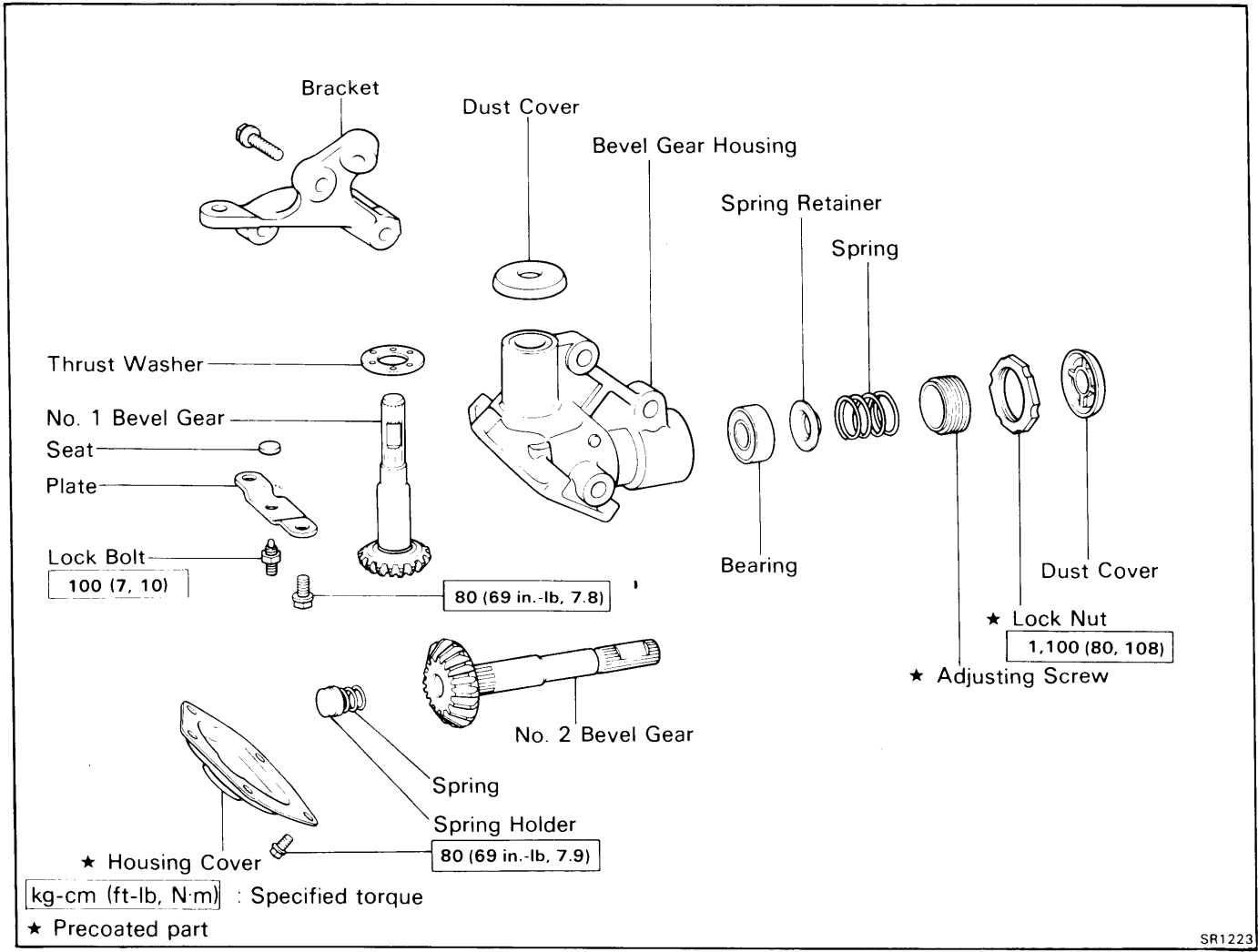

cardiagn.com

SR1223

**DISASSEMBLY OF BEVEL GEAR HOUSING**

1. CLAMP BEVEL GEAR HOUSING BRACKET IN VISE
2. REMOVE TWO DUST COVERS

**3. REMOVE ADJUSTING SCREW LOCK NUT**

Using SST, remove the adjusting screw lock nut.  
 SST 09612-10093 (09617-10010)

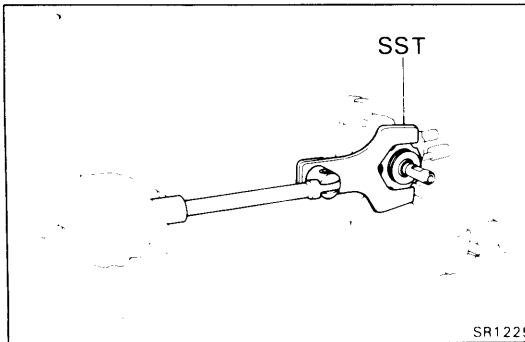
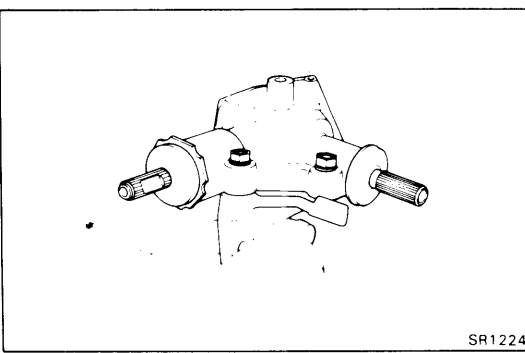

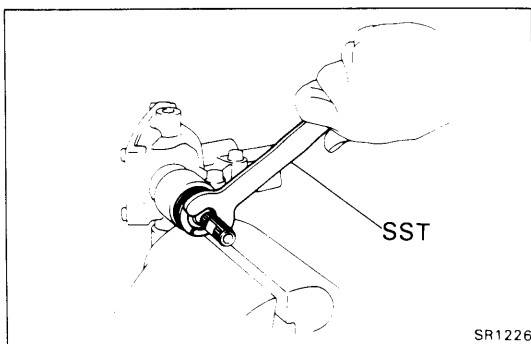

SR1226

**4. REMOVE ADJUSTING SCREW**

- (a) Using SST, remove the adjusting screw.  
SST 09612-10093 (09616-10020)
- (b) Pull out the spring from the adjusting screw.

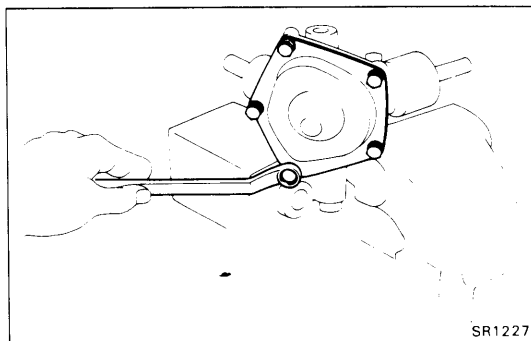

SR1227

**5. REMOVE HOUSING COVER**

Remove the five bolts and housing cover.

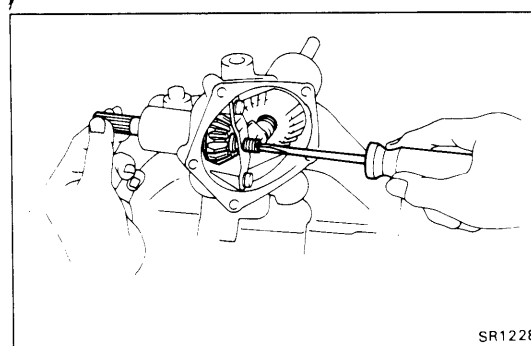

SR1228

**6. REMOVE PLATE, SEAT, SPRING AND SPRING HOLDER**

- (a) Loosen the lock nut and unscrew the adjusting bolt.
- (b) Remove the two plate set bolts and plate.
- (c) Take out the adjusting bolt seat, spring and spring holder.

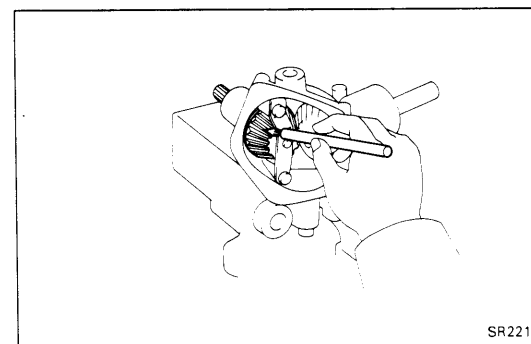

SR2214

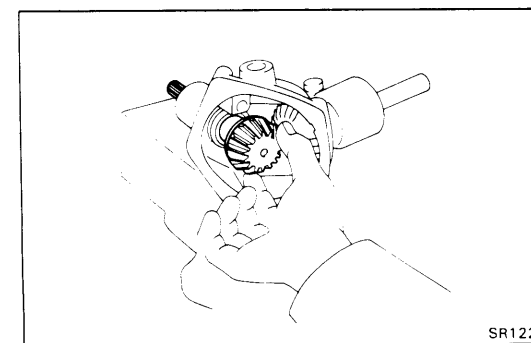
**7. WIPE OFF GREASE OF GEAR TEETH****8. INSPECT TOOTH CONTACT BETWEEN NO. 1 AND NO. 2 BEVEL GEAR**  
(See step 9 on page SR-65)

SR1229

**9. REMOVE NO.1 AND NO.2 BEVEL GEAR**

- (a) Push in the No.2 bevel gear.  
If necessary, tap the No.2 bevel gear with a plastic hammer.
- (b) Pull out the No. 1 bevel gear and thrust washer.

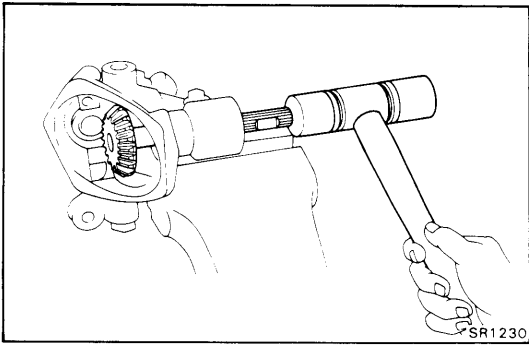

- (c) Using a plastic hammer, tap out the No.2 bevel gear.
- (d) Remove the bearing and spring retainer.

## INSPECTION AND REPAIR OF BEVEL GEAR HOUSING COMPONENTS

### 1. INSPECT NO.1 AND NO.2 BEVEL GEAR

- Check the needle roller bearing contacting surface for wear or damage.
- Check the gear teeth for wear or damage.

### 2. INSPECT NEEDLE ROLLER BEARING

Check for wear or damage.

### 3. IF NECESSARY, REPLACE NO.1 BEVEL GEAR OIL SEAL

- Using a screwdriver, pry out the oil seal.

- Using SST, drive in a new oil seal.  
SST 09612-10093 (09612-10050)

### 4. IF NECESSARY, REPLACE NO.2 BEVEL GEAR OIL SEAL

- Using a screwdriver and hammer, drive out the oil seal.

- Using SST, drive in a new oil seal.  
SST 09612-10093 (09612-10050)

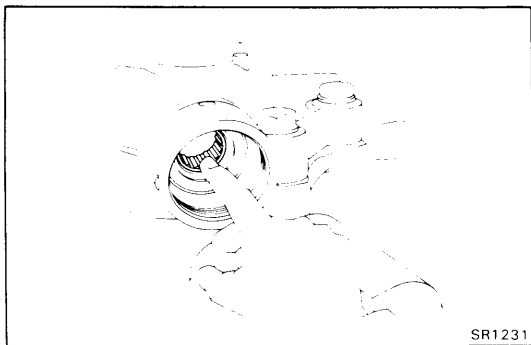

SR1231

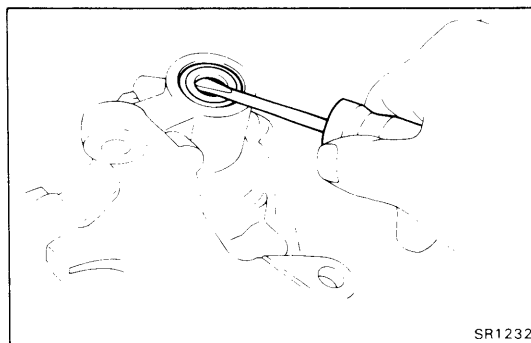

SR1232

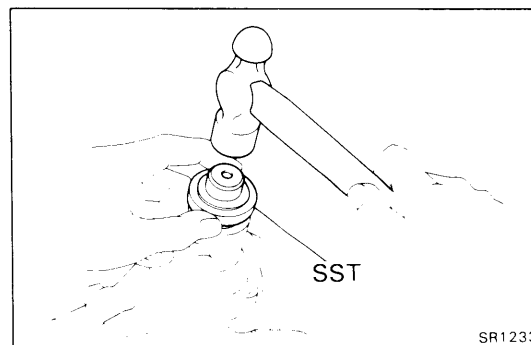

SR1233

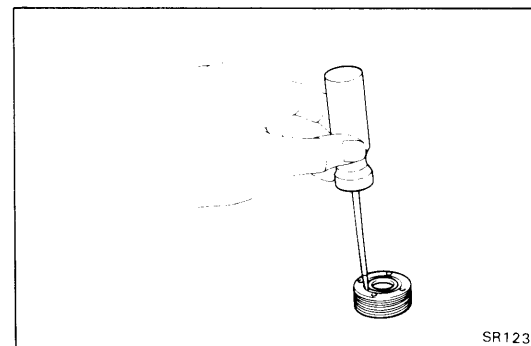

SR1234

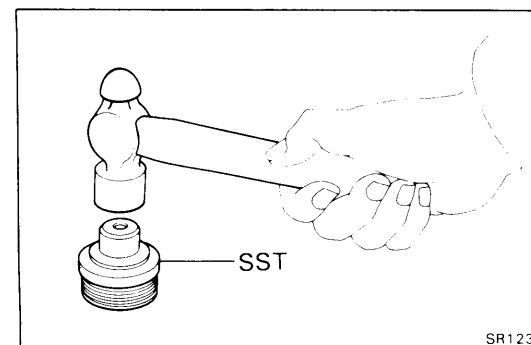

SR1235

**ASSEMBLY OF BEVEL GEAR HOUSING**

(See page SR-59)

1. PACK FOLLOWING PARTS WITH MOLYBDENUM DISULPHIDE LITHIUM BASE GREASE:

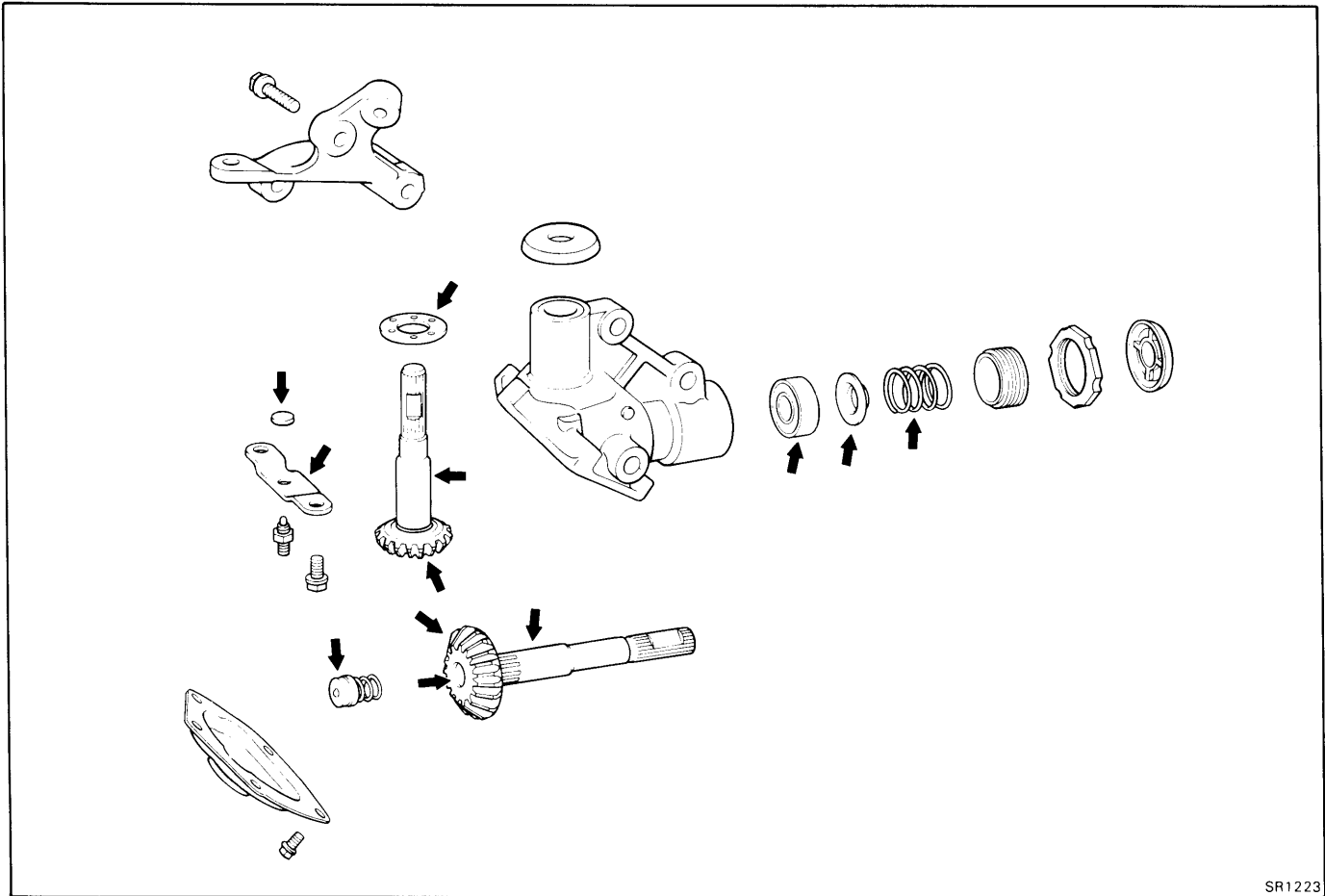

SR1223

**2. INSTALL NO.2 BEVEL GEAR AND BEARING**

- (a) Insert No.2 bevel gear into the housing.
  - (b) Using SST, press in the bearing.
- SST 09612-10093 (09612-10061)

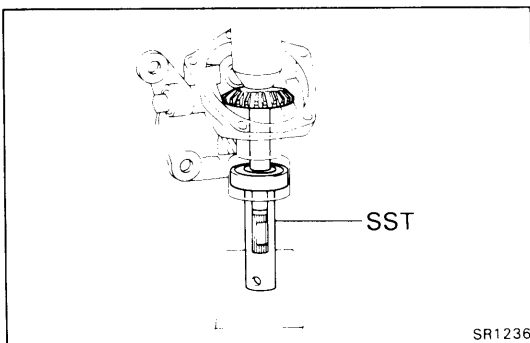

SR1236

**3. INSTALL NO.1 BEVEL GEAR AND THRUST WASHER**

- (a) Install the thrust washer to the No. 1 bevel gear.
- (b) Install the No.1 bevel gear into the housing.

NOTE: Line up the cutout portion of the No.1 and No.2 bevel gear.

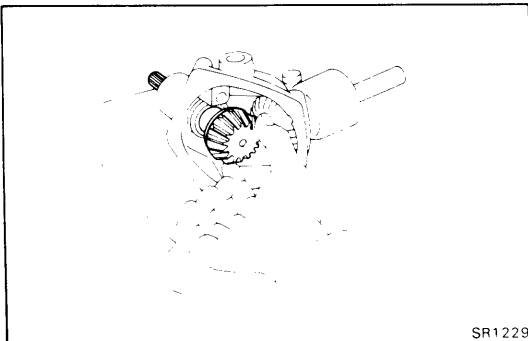

SR1229

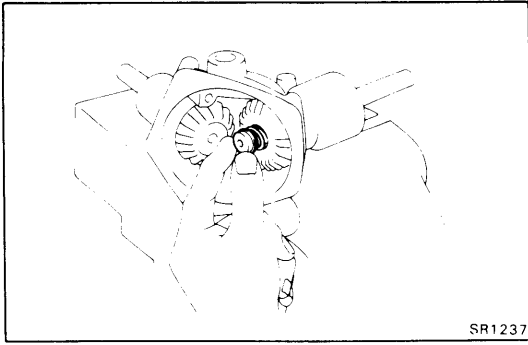

#### 4. INSTALL SPRING AND SPRING HOLDER TO NO.2 BEVEL GEAR

Install the spring with the spring holder to the No.2 bevel gear.

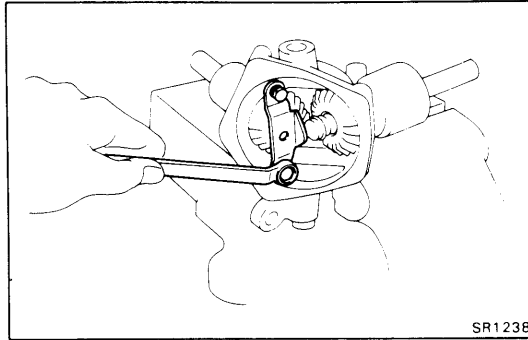

#### 5. INSTALL PLATE, ADJUSTING BOLT AND SEAT

(a) Install the plate with two bolts.

**Torque: 80 kg-cm (69 in.-lb, 7.8 N·m)**

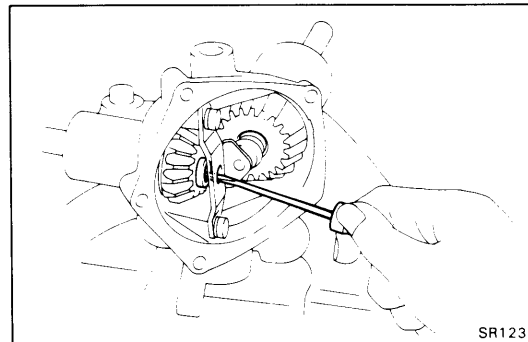

(b) Install the adjusting bolt seat.

(c) Screw the adjusting bolt, until touch to the seat.

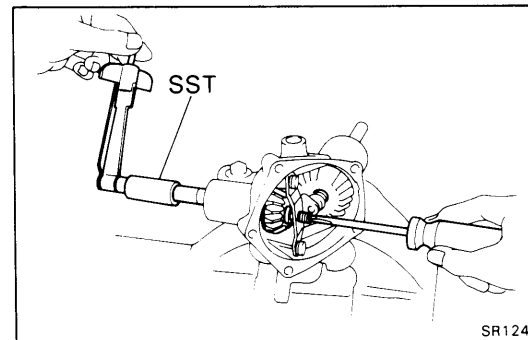

#### 6. ADJUST NO.1 BEVEL GEAR PRELOAD

(a) Using a screwdriver and SST, adjust the No.1 bevel gear preload, and then No.1 bevel gear is no axial play.

SST 09612-10093 (09616-10010)

**Preload (turning): 0.8 – 1.5 kg-cm  
(0.7 – 1.3 in.-lb, 0.08 – 0.15 N·m)**

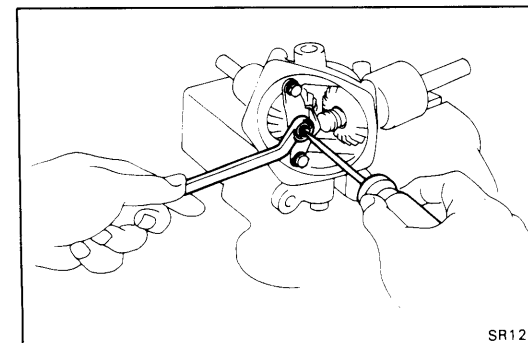

(b) Using a screwdriver, holding the adjusting bolt, and install and torque the lock nut.

**Torque: 100 kg-cm (7 ft-lb, 10 N·m)**

(c) Recheck the No.1 bevel gear preload.

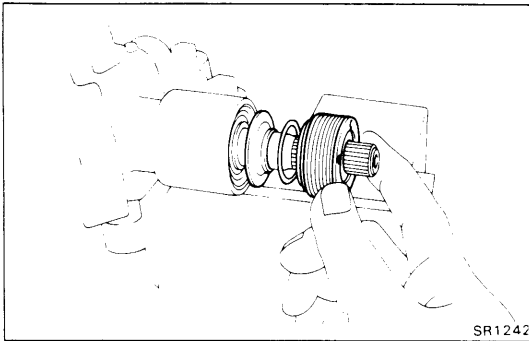

### 7. INSTALL SPRING RETAINER, SPRING AND ADJUSTING SCREW

- (a) Install the spring retainer into the housing.
- (b) Install the spring to the adjusting screw.
- (c) Coat liquid sealer to the adjusting screw.

**Sealant: Part No. 08833-00080, THREE BOND 1344, LOCTITE 242 or equivalent**

- (d) Install the adjusting screw to the housing.

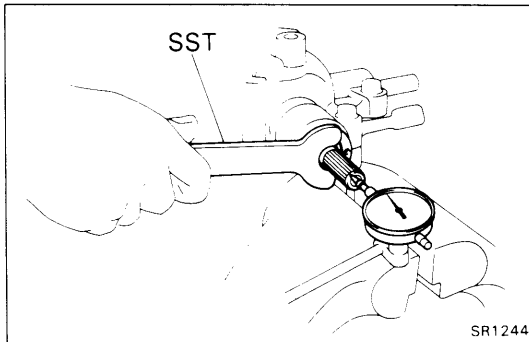

### 8. ADJUST TOTAL PRELOAD

- (a) Using SST and dial indicator, tighten the adjusting screw, until the No. 1 and No. 2 bevel gear back lash is 0.

SST 09612-10093 (09616-10020)

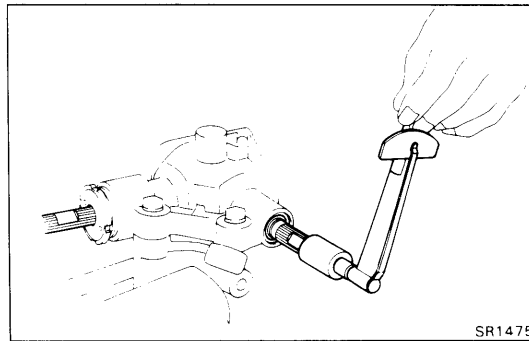

- (b) Turn the No. 1 bevel gear left and right 5 times and snug it.

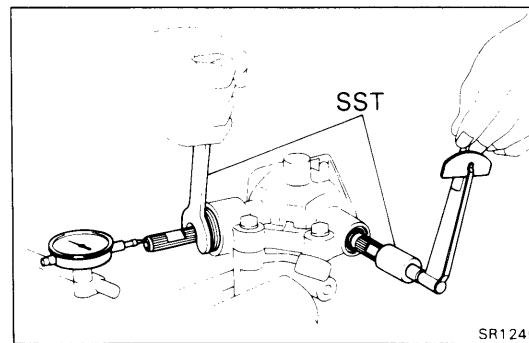

- (c) Using SST, unscrew the adjusting screw little by little and measure the total preload within specification.

SST 09612-10093 (09616-10010, 09616-10020)

**Preload (turning): 1.5 – 4.0 kg·cm  
(1.3 – 3.5 in.-lb, 0.15 – 0.39 N·m)**

**CAUTION:** When loosening the adjusting screw, take care that the back lash is not more than 0.36 mm (0.0142 in.).

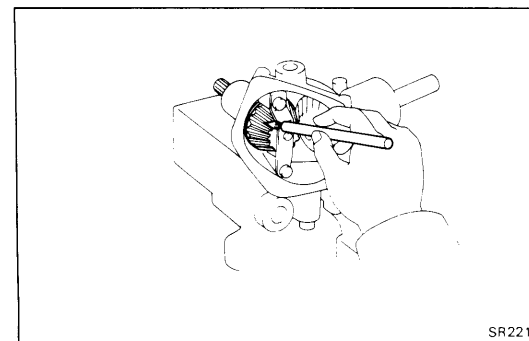

### 9. INSPECT TOOTH CONTACT BETWEEN NO. 1 AND NO. 2 BEVEL GEAR

- (a) Coat two teeth at symmetrical position on the No. 1 bevel gear with red lead.

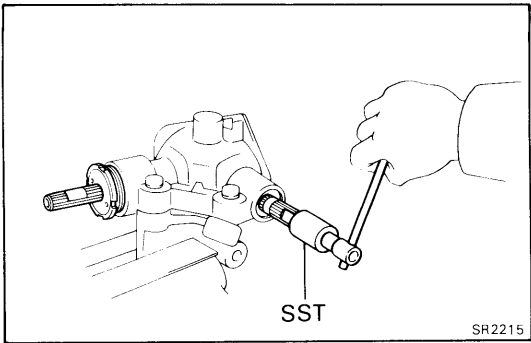

- (b) Using SST, turn the No. 2 bevel gear in both directions. SST 09612-10093 (09616-10010)
- (c) Inspect the tooth pattern of the No. 2 bevel gear. If incorrect, reassemble the bevel gear housing.

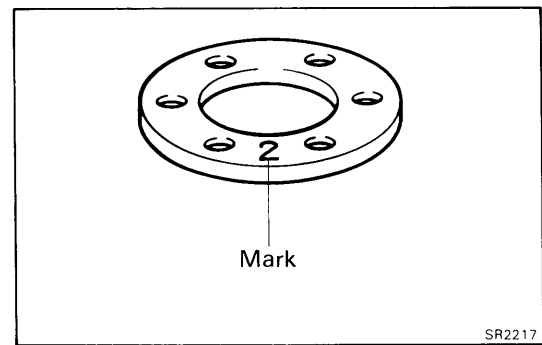
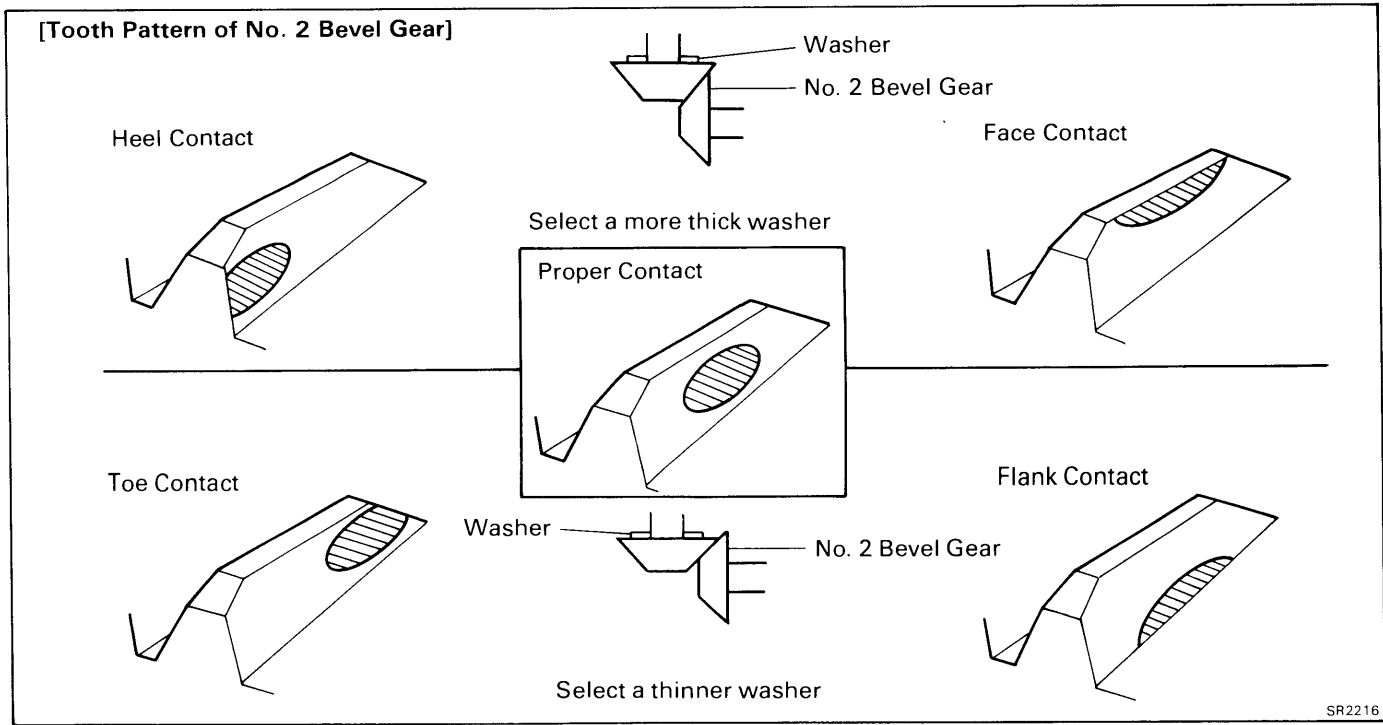

If the teech are not contacting properly, use the following chart to select a proper washer for correction.

Mark	Thrust washer thickness	mm (in.)
2	1.875 — 1.925	(0.0738 — 0.0758)
3	1.925 — 1.975	(0.0758 — 0.0778)
4	1.975 — 2.025	(0.0778 — 0.0797)
5	2.025 — 2.075	(0.0797 — 0.0817)
6	2.075 — 2.125	(0.0817 — 0.0837)
7	2.125 — 2.175	(0.0837 — 0.0856)
8	2.175 — 2.225	(0.0856 — 0.0876)

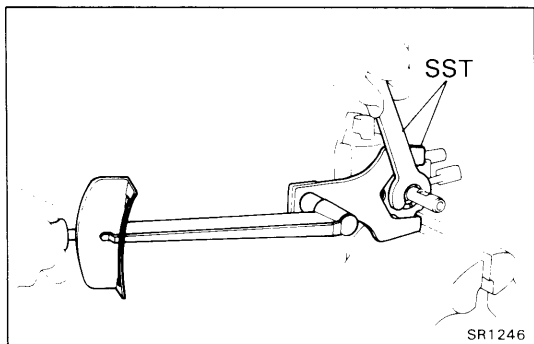

#### 10. INSTALL ADJUSTING SCREW LOCK NUT

- (a) Coat liquid sealer to the lock nut thread and housing surface.

**Sealant:** Part No. 08833-00080, THREE BOND 1344, LOCTITE 242 or equivalent

- (b) Using SST, install and torque the lock nut.  
SST 09612-10093 (09616-10020, 09617-10010)

**Torque:** 1,100 kg-cm (80 ft-lb, 108 N·m)

- (c) Recheck the total preload.

#### 11. PACK MOLYBDENUM DISULPHIDE LITHIUM BASE GREASE INTO GEAR HOUSING

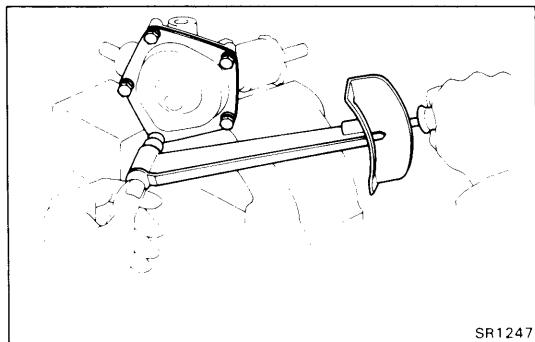

#### 12. INSTALL HOUSING COVER

- (a) Coat liquid sealer to the contacting surface of housing cover.

**Sealant:** Part No. 08833-00080, THREE BOND 1344, LOCTITE 242 or equivalent

- (b) Install the housing cover with five bolts and torque bolts.

**Torque:** 80 kg-cm (69 in.-lb, 7.8 N·m)

#### 13. INSTALL TWO DUST COVERS

## INSTALLATION OF BEVEL HOUSING

(See page SR-58)

### 1. CONNECT BEVEL GEAR TO TWO UNIVERSAL JOINTS

Line up the cutout portion to the bevel gear and universal joint, and connect them.

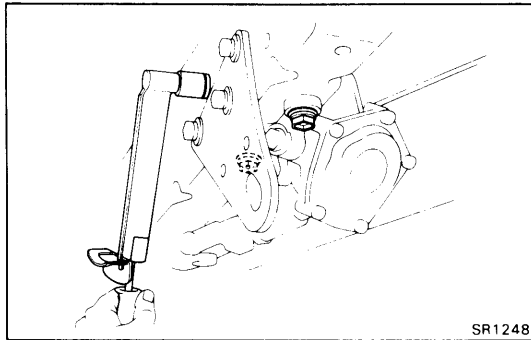

### 2. INSTALL BEVEL GEAR HOUSING TO FRAME

(a) Install the bevel gear housing with the bracket to the frame.

(b) Install and torque the three bolts.

**Torque: 400 kg-cm (29 ft-lb, 39 N·m)**

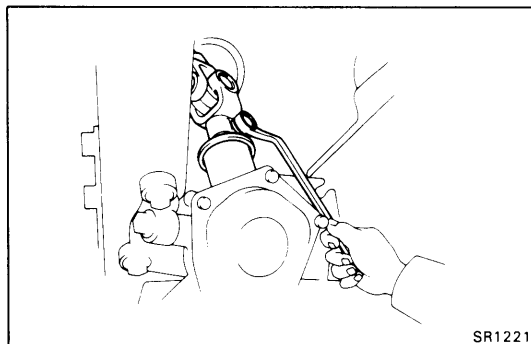

### 3. INSTALL AND TORQUE TWO UNIVERSAL JOINT BOLTS

**Torque:**

**Main shaft side 250 kg-cm (18 ft-lb, 25 N·m)**

**Torque shaft side 360 kg-cm (26 ft-lb, 35 N·m)**

### 4. CHECK STEERING WHEEL CENTER POINT