

F RELAY LOCATIONS

○ : Driver Side J/B **LHD : Instrument Panel Brace LH (See Page 21)**
RHD : Instrument Panel Brace RH (See Page 21)

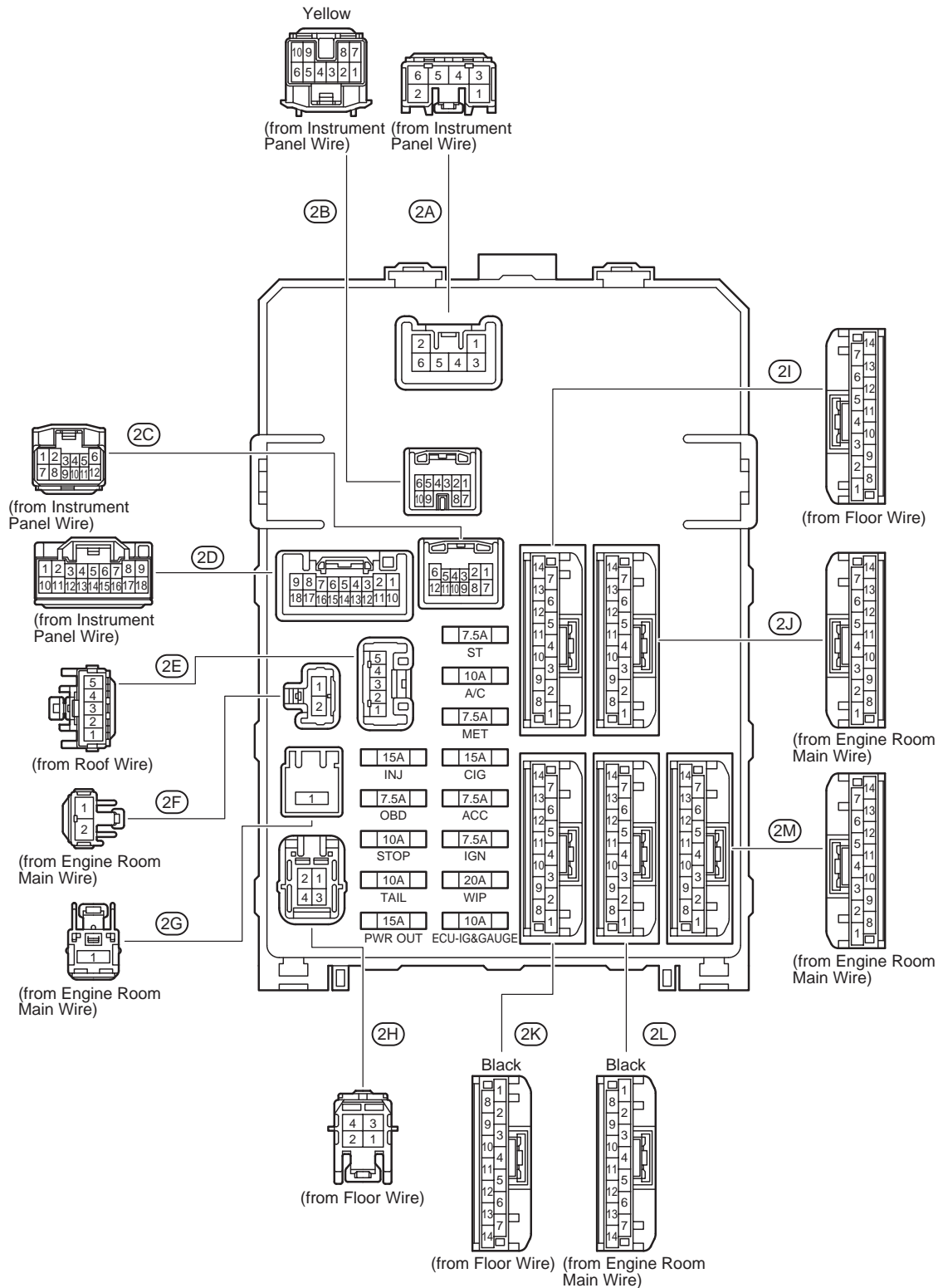

cardiagn.com

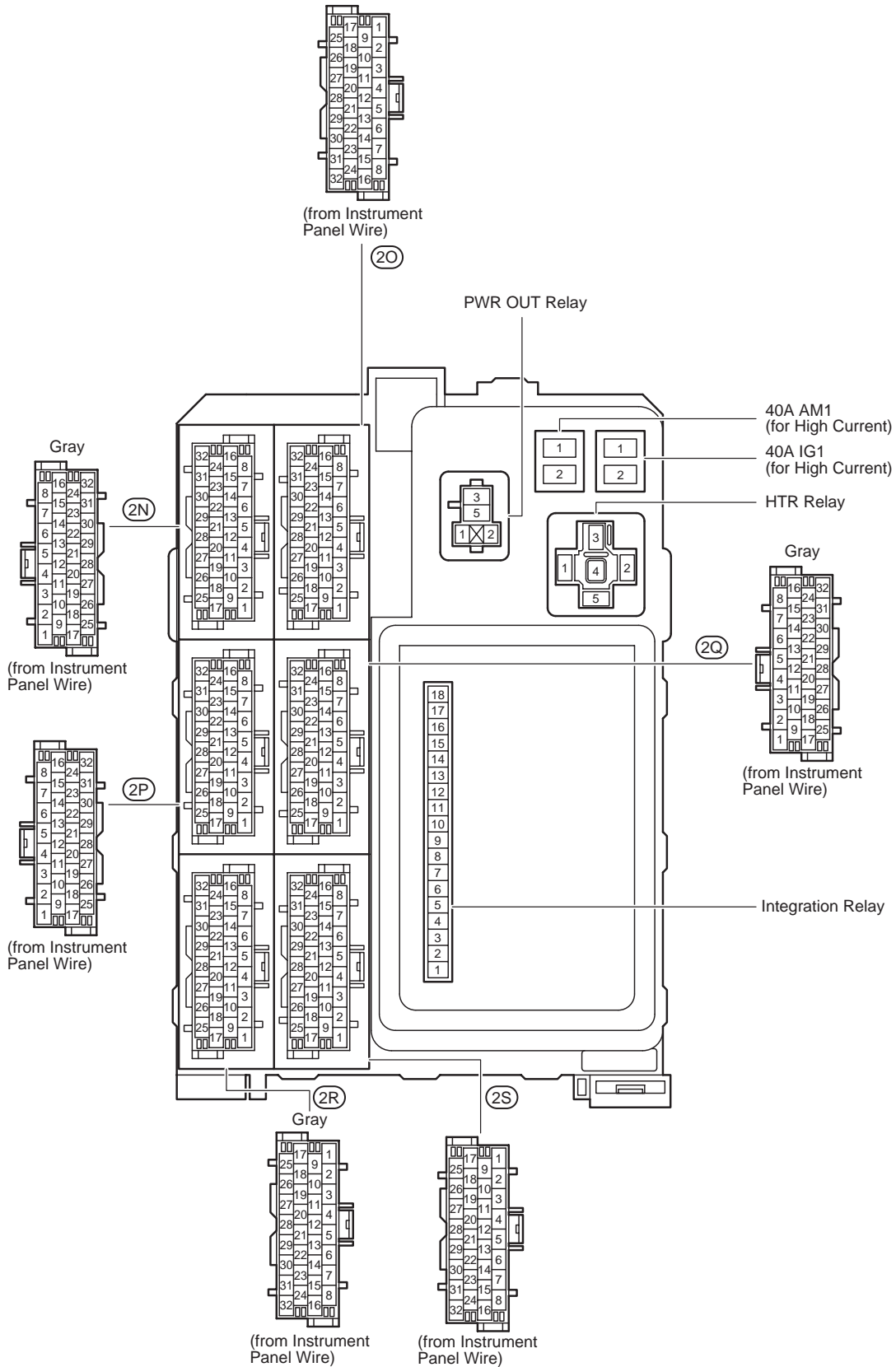

HILUX (EM1815E)

F RELAY LOCATIONS

[Driver Side J/B Inner Circuit]

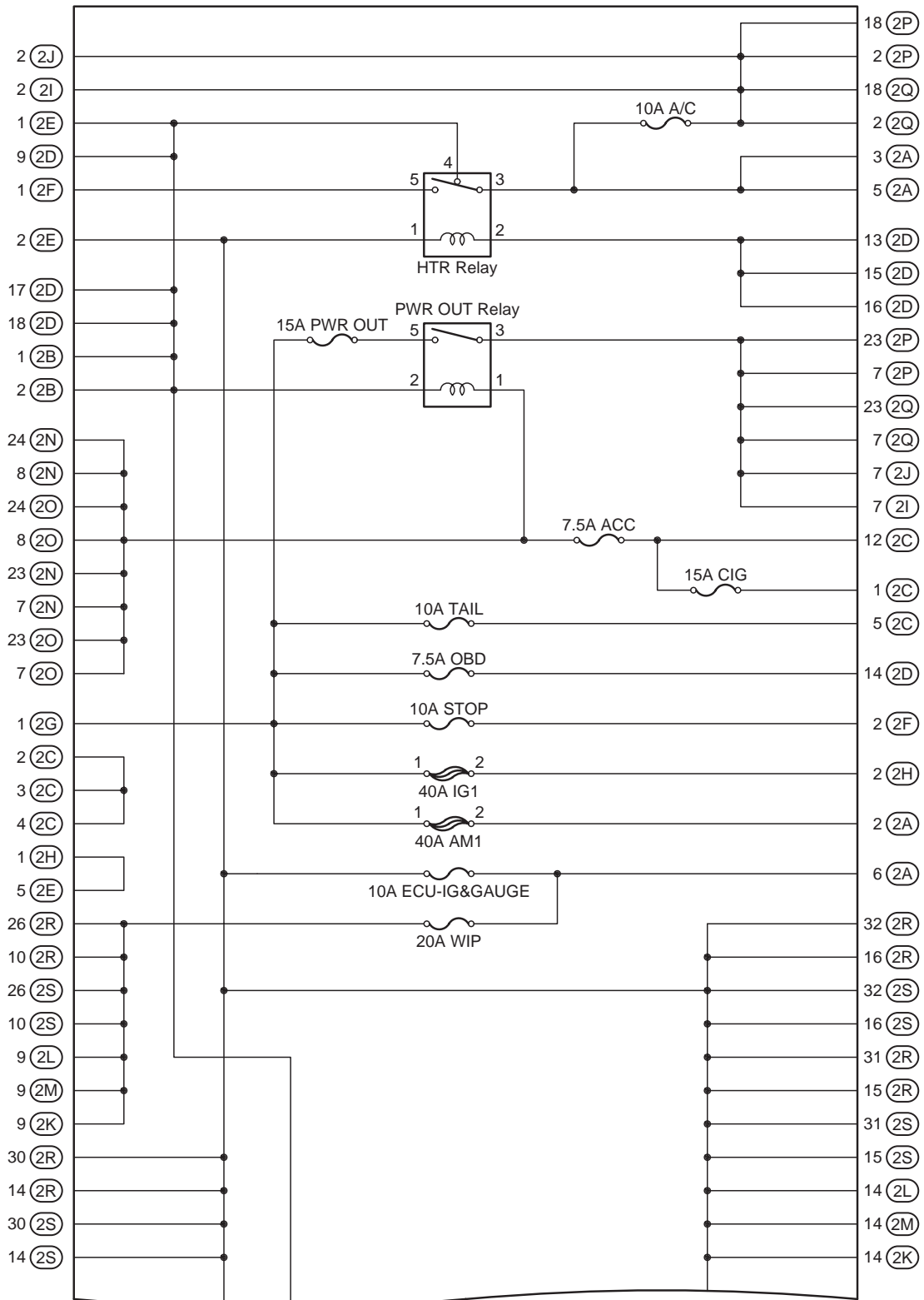

(Cont. Next Page)

(Cont'd)

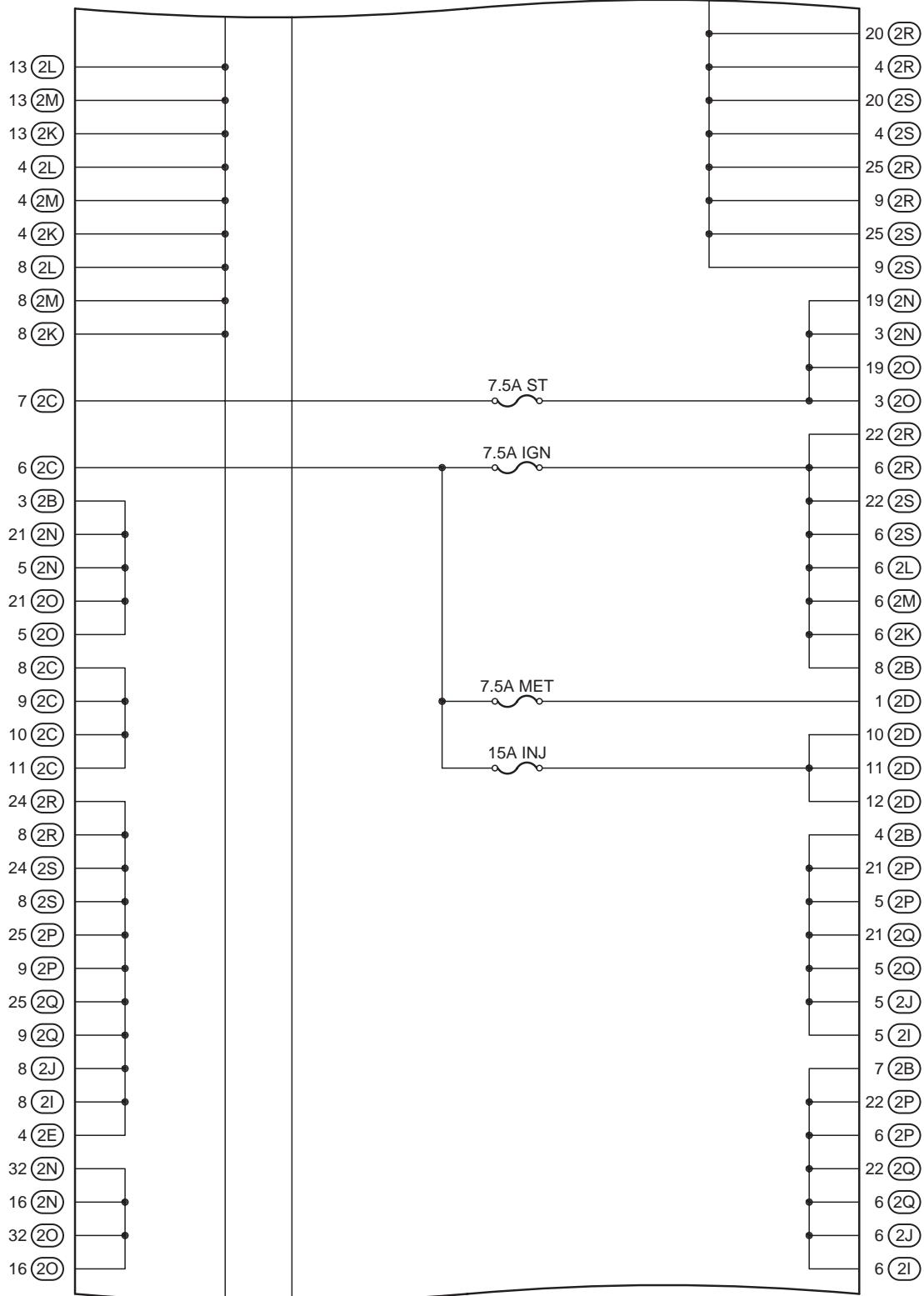

(Cont. Next Page)

(Cont'd)

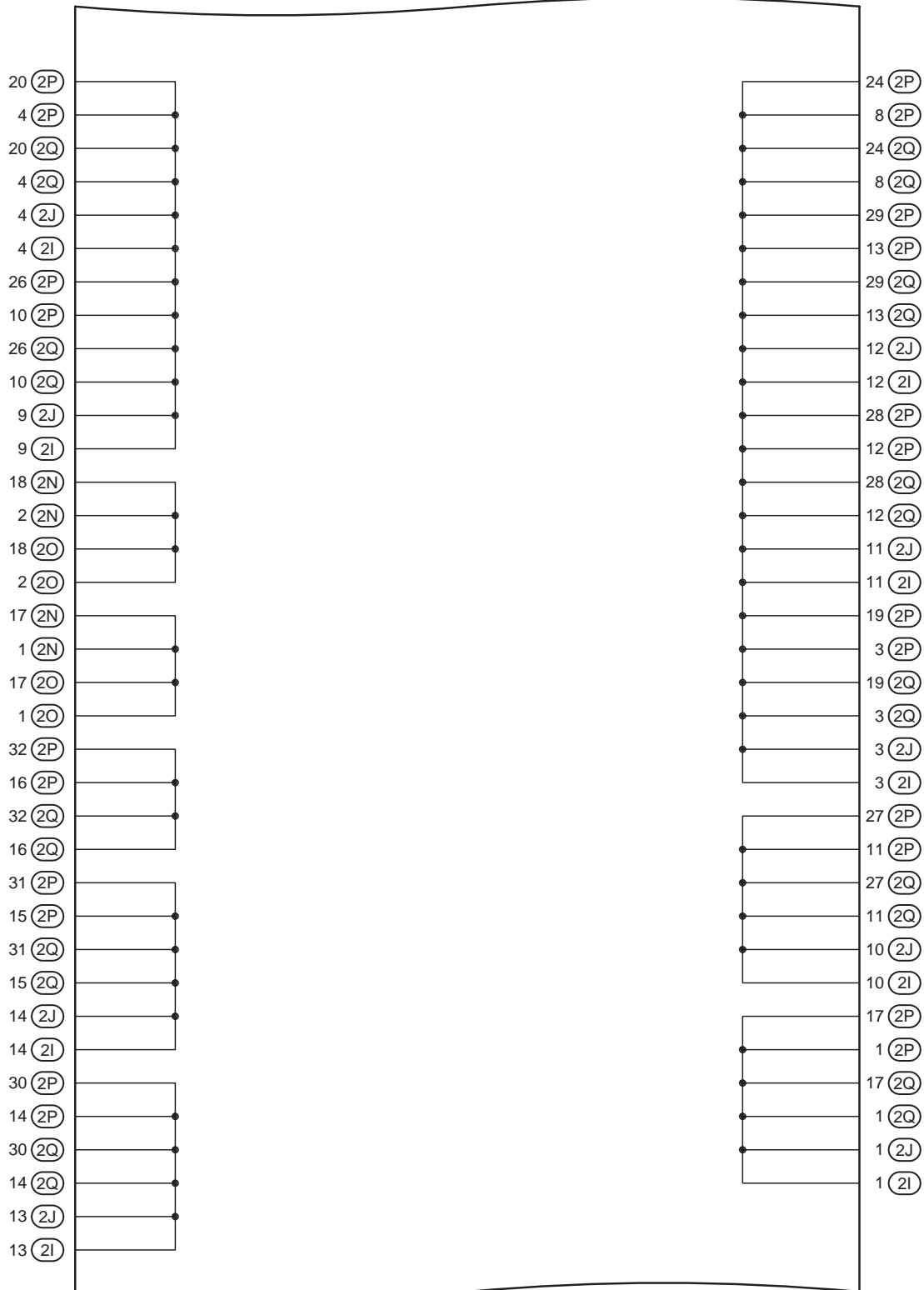

(Cont. Next Page)

F RELAY LOCATIONS

[Driver Side J/B Inner Circuit]

(Cont'd)

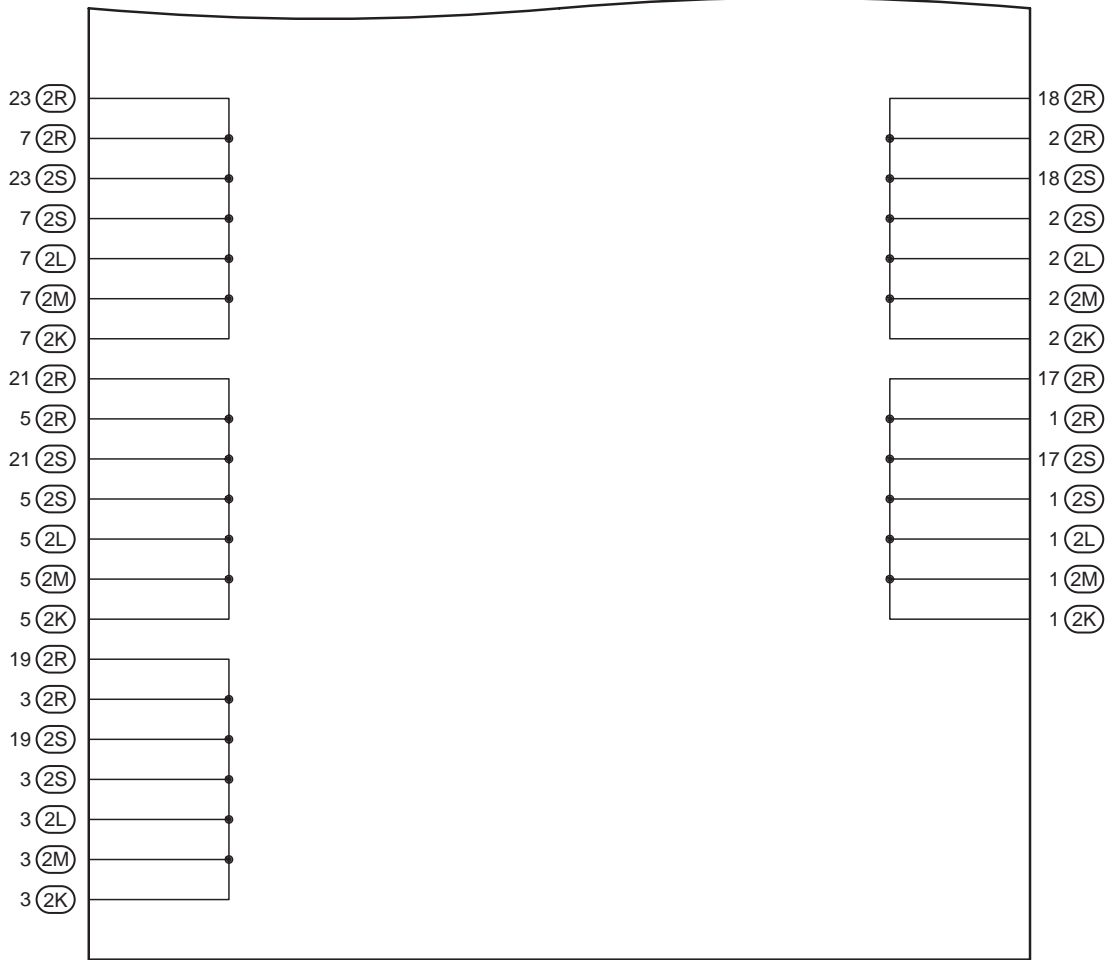

F RELAY LOCATIONS

[Engine Compartment] (LHD)

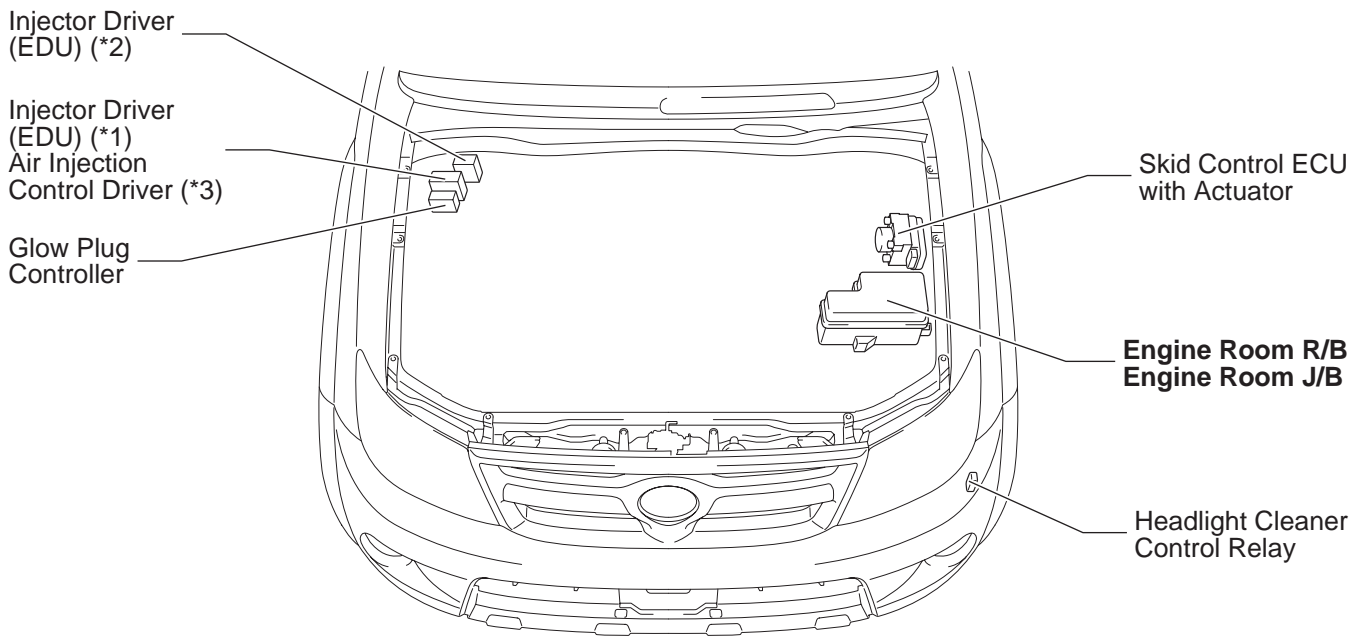

- * 1:1KD-FTV w/ DPF, 2KD-FTV w/ DPF
- * 2:1KD-FTV w/o DPF, 2KD-FTV w/o DPF
- * 3:2TR-FE

(RHD)

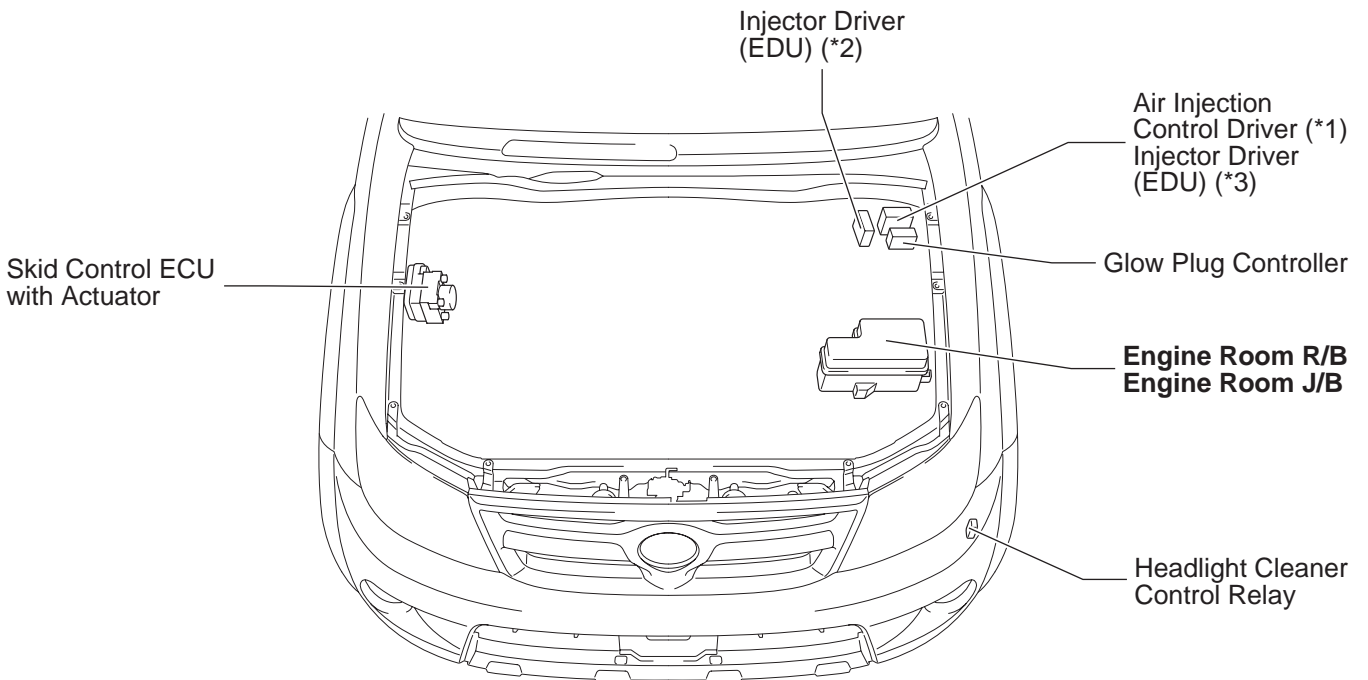

- * 1:2TR-FE
- * 2:1KD-FTV w/ DPF, 2KD-FTV w/ DPF
- * 3:1KD-FTV w/o DPF, 2KD-FTV w/o DPF

F RELAY LOCATIONS

[Engine Compartment] (LHD)

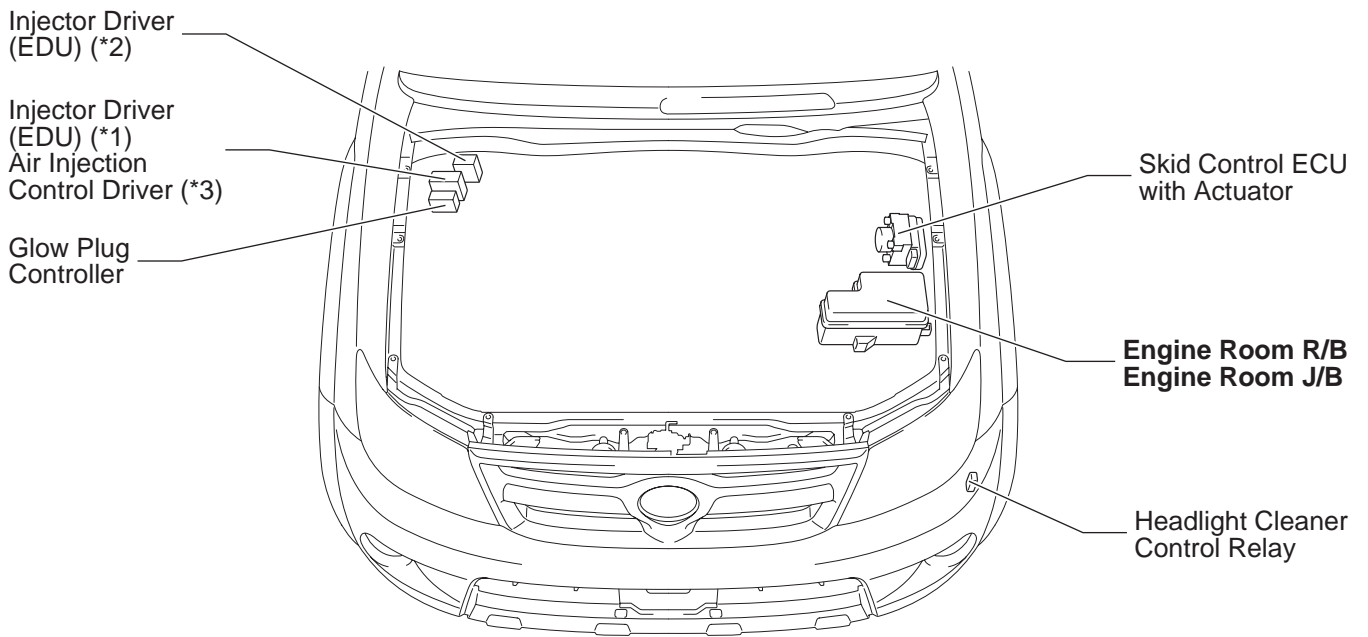

- * 1:1KD-FTV w/ DPF, 2KD-FTV w/ DPF
- * 2:1KD-FTV w/o DPF, 2KD-FTV w/o DPF
- * 3:2TR-FE

(RHD)

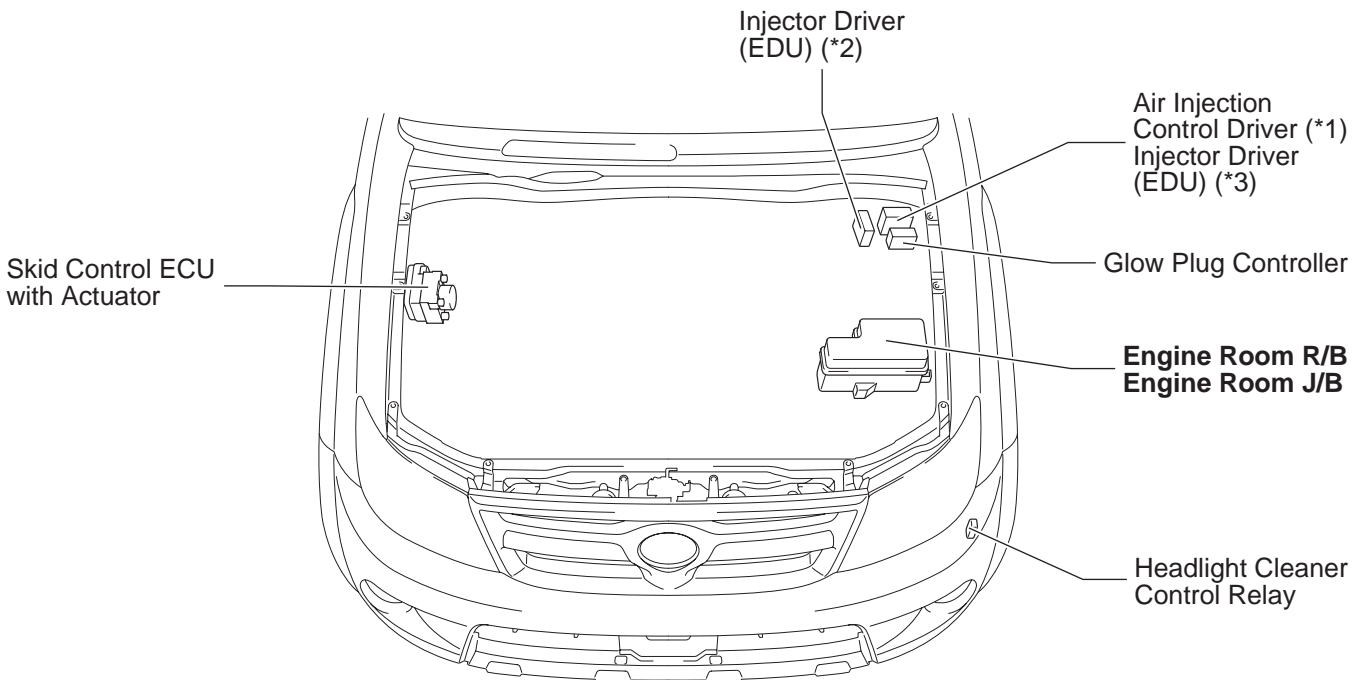

- * 1:2TR-FE
- * 2:1KD-FTV w/ DPF, 2KD-FTV w/ DPF
- * 3:1KD-FTV w/o DPF, 2KD-FTV w/o DPF

F RELAY LOCATIONS

① : Engine Room R/B ○ : Engine Room J/B	Engine Compartment Left (See Page 20)
--	--

(Inner Circuit : See Page 26)

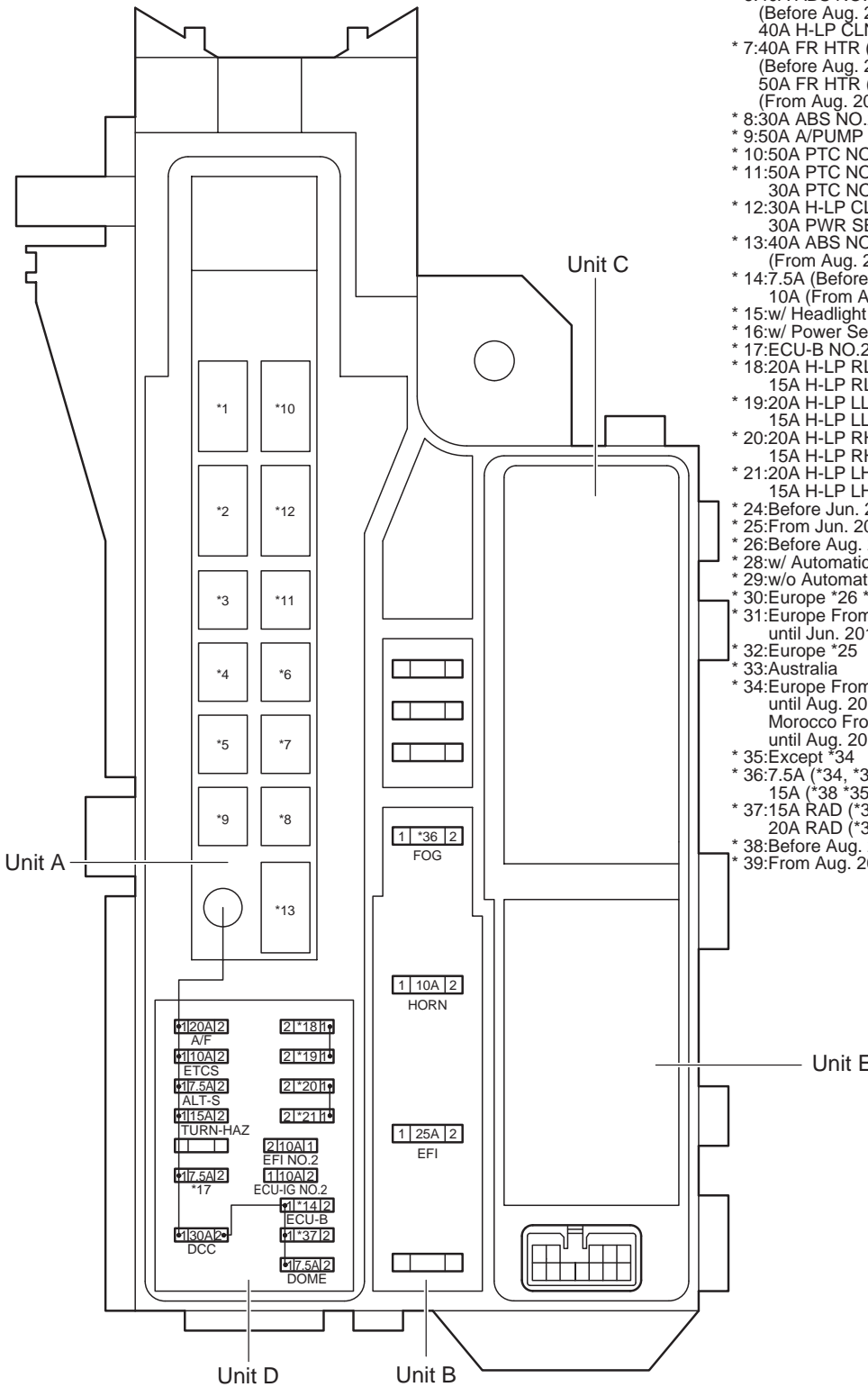

- * 1:100A ALT (for High Current)
- * 2:80A GLOW (for High Current)
- * 3:50A BATT P/I (for High Current)
- * 4:30A AM2 (for High Current)
- * 5:40A MAIN (for High Current)
- * 6:40A ABS NO.1 (for High Current)
(Before Aug. 2008 Production)
40A H-LP CLN (for High Current) (*15 *25)
- * 7:40A FR HTR (for High Current)
(Before Aug. 2009 Production)
50A FR HTR (for High Current)
(From Aug. 2009 Production)
- * 8:30A ABS NO.2 (for High Current)
- * 9:50A A/PUMP (for High Current)
- * 10:50A PTC NO.1 (for High Current)
- * 11:50A PTC NO.2 (for High Current) (*31, *32)
30A PTC NO.2 (for High Current) (*30, *33)
- * 12:30A H-LP CLN (for High Current) (*15 *24)
30A PWR SEAT (for High Current) (*16)
- * 13:40A ABS NO.1 (for High Current)
(From Aug. 2008 Production)
- * 14:7.5A (Before Aug. 2008 Production)
10A (From Aug. 2008 Production)
- * 15:w/ Headlight Cleaner
- * 16:w/ Power Seat
- * 17:ECU-B NO.2
- * 18:20A H-LP RL (*24)
15A H-LP RL (*25)
- * 19:20A H-LP LL (*24)
15A H-LP LL (*25)
- * 20:20A H-LP RH (*24)
15A H-LP RH (*25)
- * 21:20A H-LP LH (*24)
15A H-LP LH (*25)
- * 24:Before Jun. 2011 Production
- * 25:From Jun. 2011 Production
- * 26:Before Aug. 2010 Production
- * 28:w/ Automatic A/C
- * 29:w/o Automatic A/C
- * 30:Europe *26 *29, Europe *24 *28
- * 31:Europe From Aug. 2010 Production
until Jun. 2011 Production *29
- * 32:Europe *25
- * 33:Australia
- * 34:Europe From Aug. 2012 Production
until Aug. 2013 Production,
Morocco From Aug. 2012 Production
until Aug. 2013 Production
- * 35:Except *34
- * 36:7.5A (*34, *39)
15A (*38 *35)
- * 37:15A RAD (*38)
20A RAD (*39)
- * 38:Before Aug. 2013 Production
- * 39:From Aug. 2013 Production

cardiagn.com

Unit A

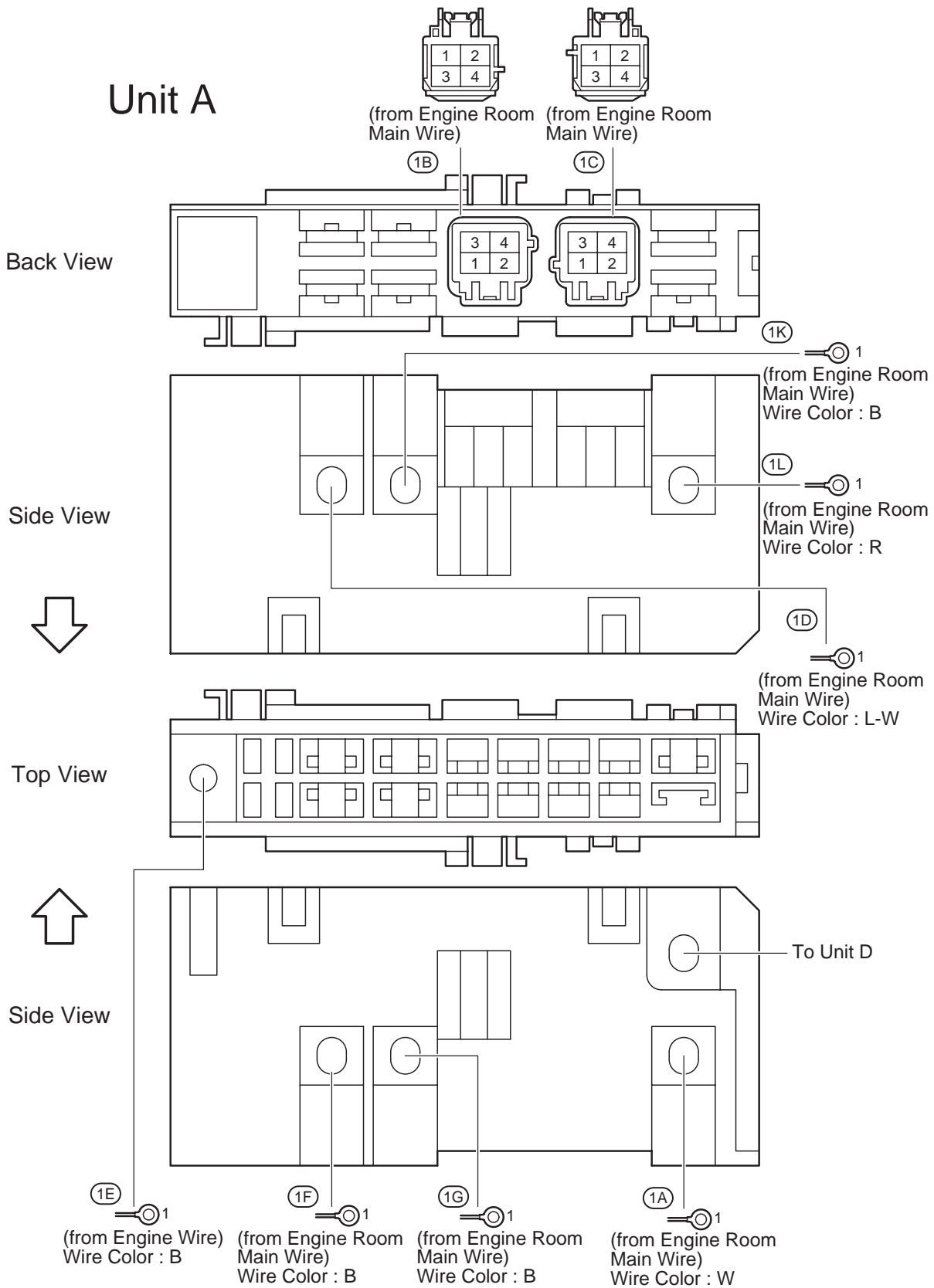

cardiagn.com

F RELAY LOCATIONS

① : Engine Room R/B	Engine Compartment Left (See Page 20)
○ : Engine Room J/B	

(Inner Circuit : See Page 27)

Unit B

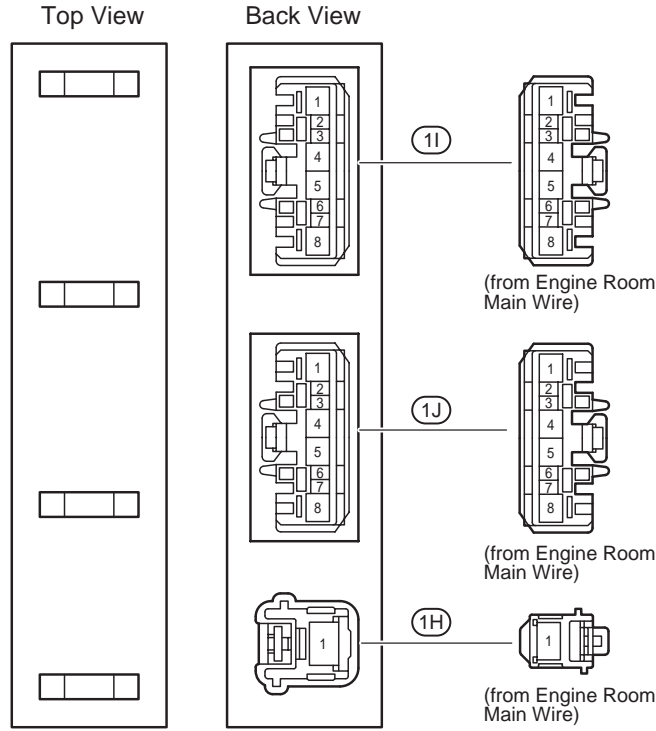

Unit C

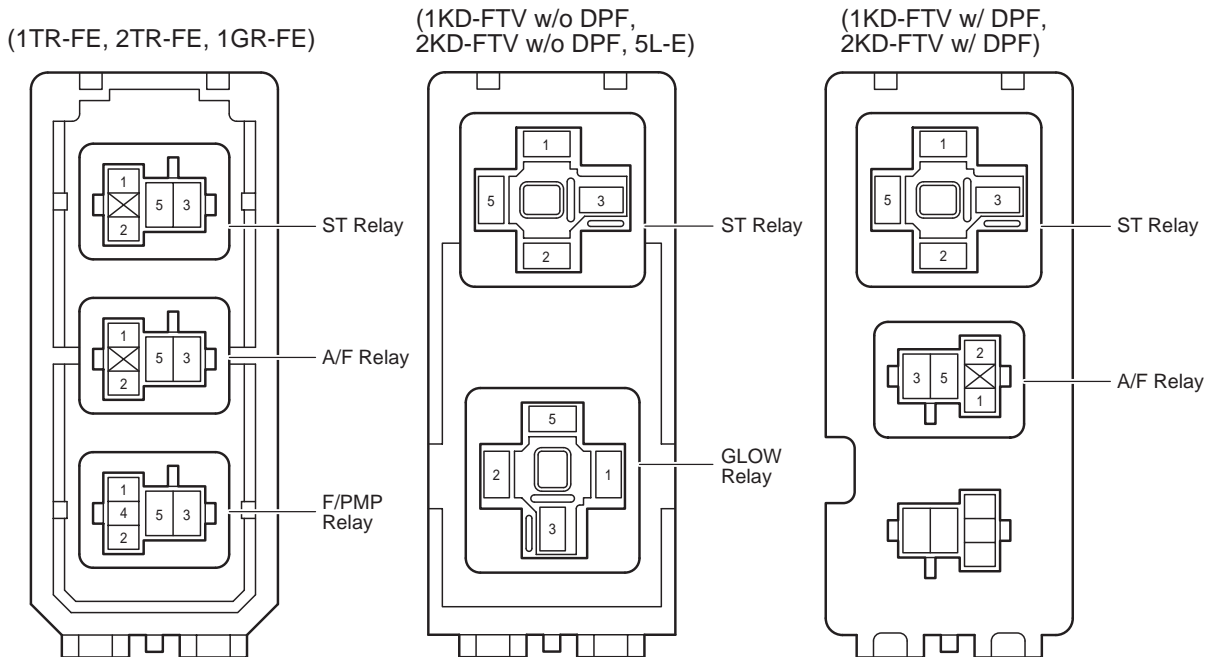

Unit E

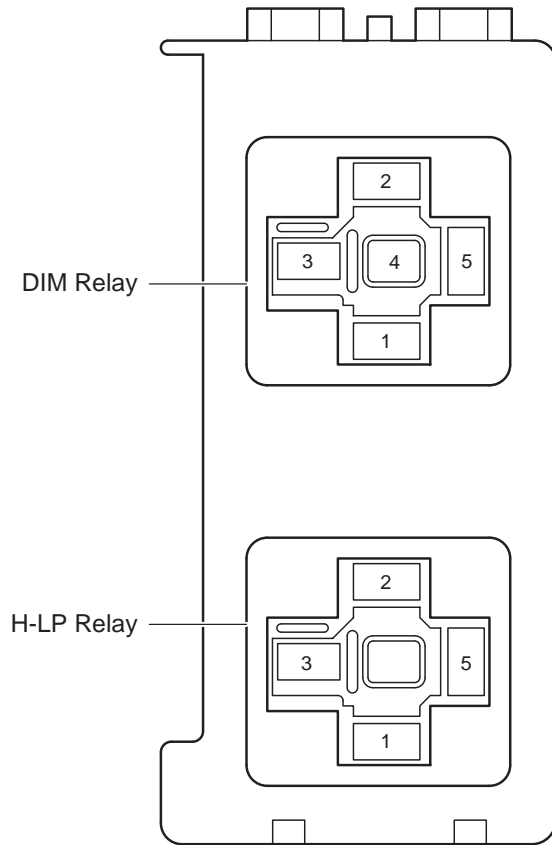

cardiagn.com

F RELAY LOCATIONS

[Engine Room R/B and Engine Room J/B Inner Circuit]

- * 1: Before Aug. 2008 Production
- * 2: From Aug. 2008 Production
- * 3: Before Aug. 2009 Production
- * 4: From Aug. 2009 Production
- * 5: Europe *15 *14, Europe *11 *13
- * 6: Europe From Aug. 2010 Production until Jun. 2011 Production *14

- * 7: w/ Headlight Cleaner
- * 8: w/ Power Seat
- * 11: Before Jun. 2011 Production
- * 12: From Jun. 2011 Production
- * 13: w/ Automatic A/C
- * 14: w/o Automatic A/C
- * 15: Before Aug. 2010 Production

- * 17: Europe *12
- * 18: Australia
- * 19: Before Aug. 2013 Production
- * 20: From Aug. 2013 Production

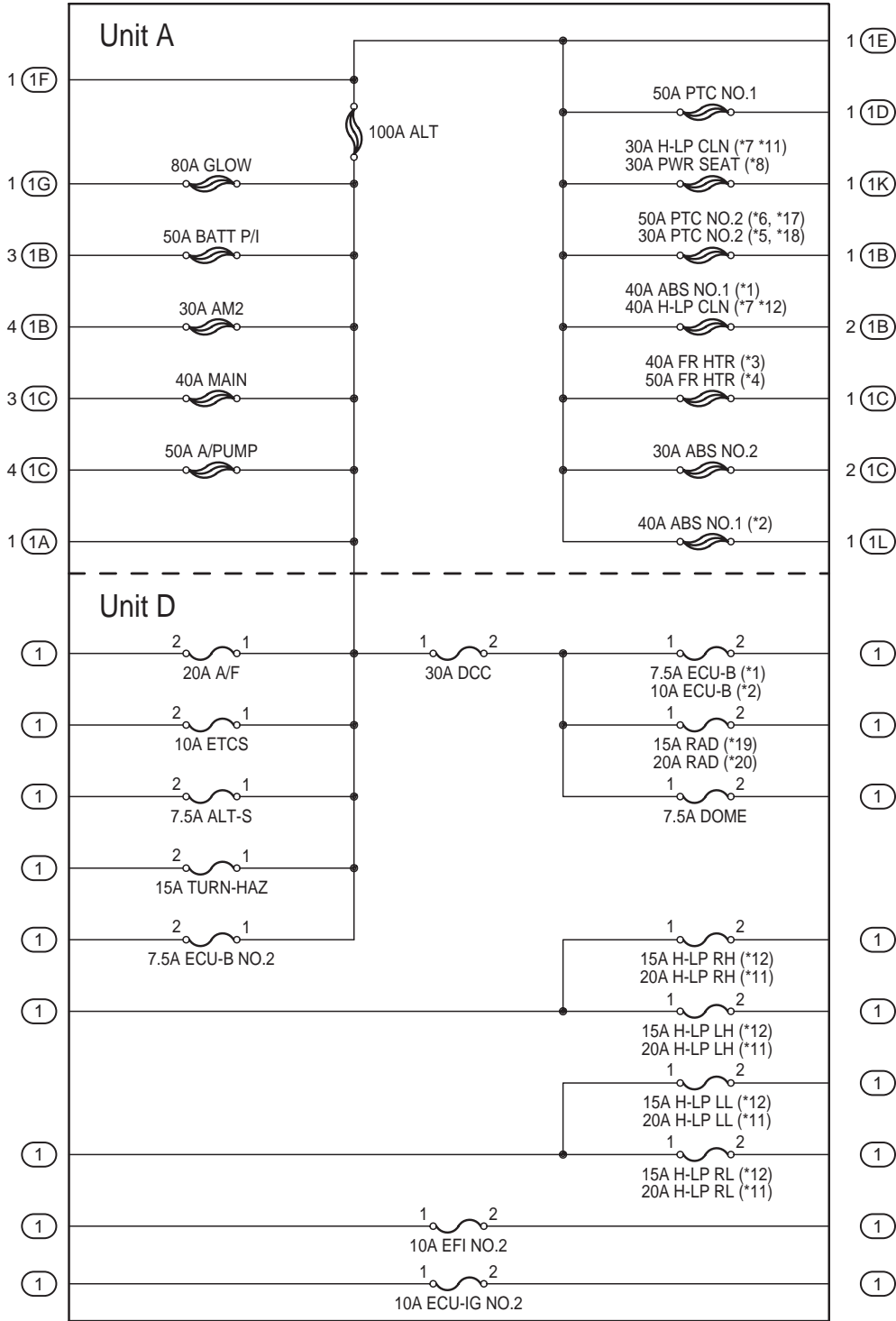

cardiagn.com

- * 1:1GR-FE, 1TR-FE, 2TR-FE
- * 2:1KD-FTV, 2KD-FTV
- * 3:Europe From Aug. 2012 Production until Aug. 2013 Production,
Morocco From Aug. 2012 Production until Aug. 2013 Production
- * 4:Except *3
- * 5:Before Aug. 2013 Production
- * 6:From Aug. 2013 Production

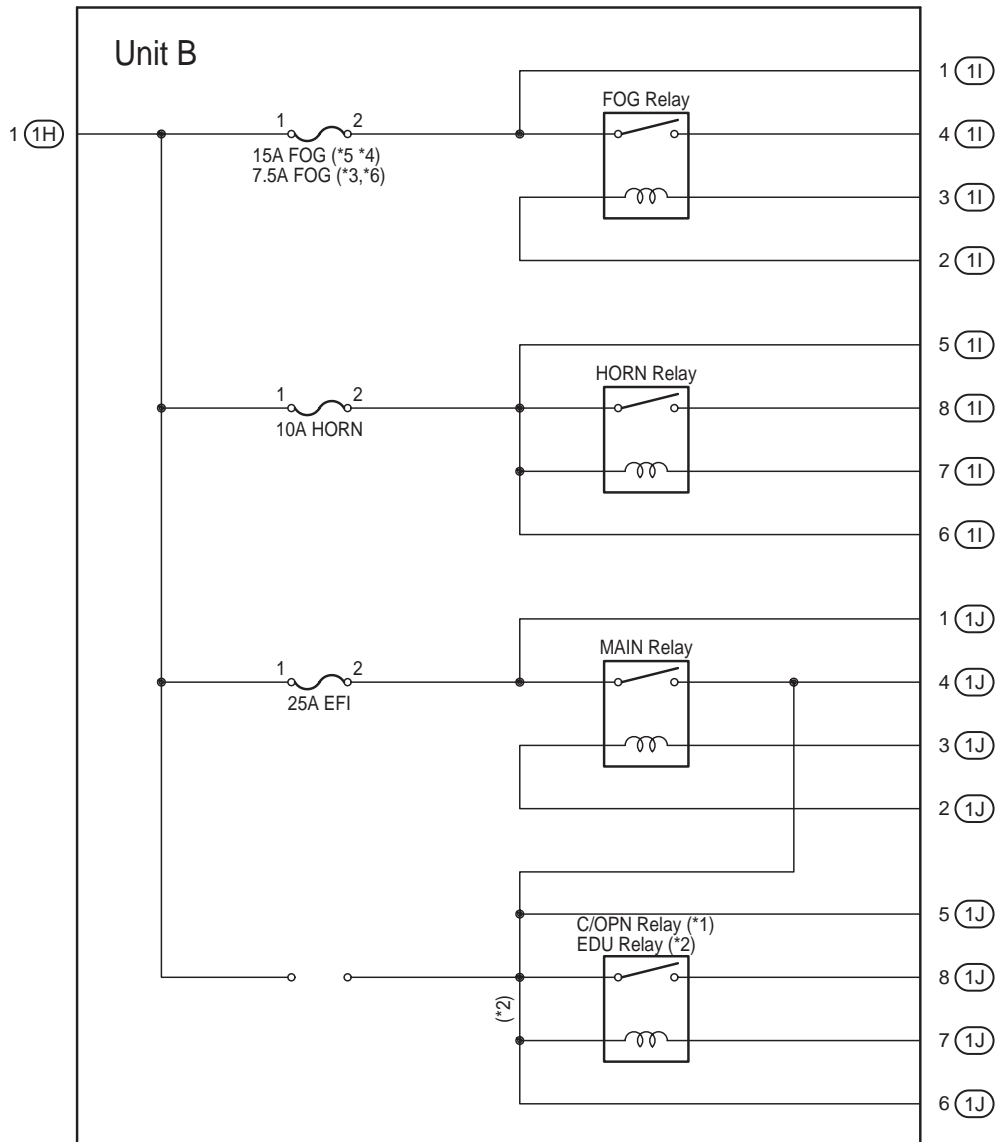

**[Instrument Panel]
(LHD)**

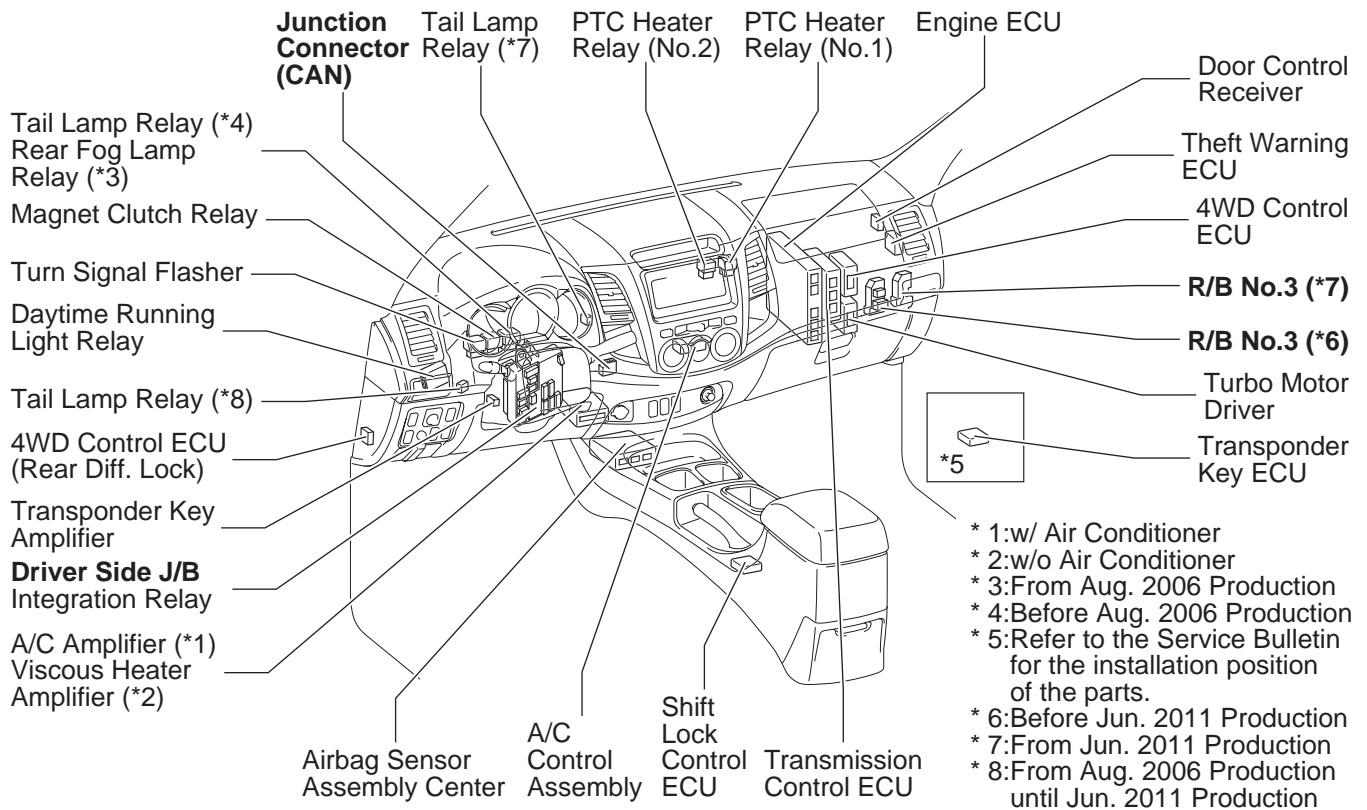

(RHD)

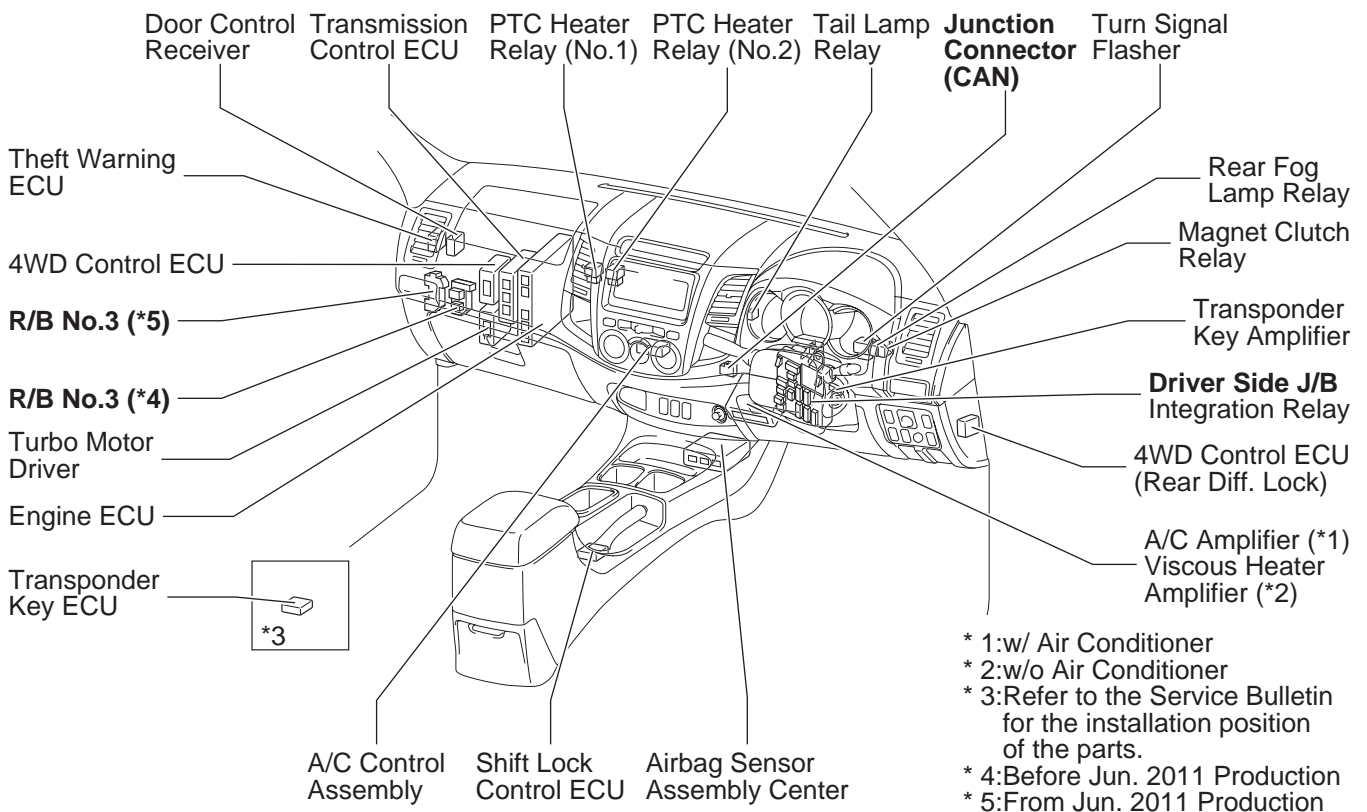

**[Instrument Panel]
(LHD)**

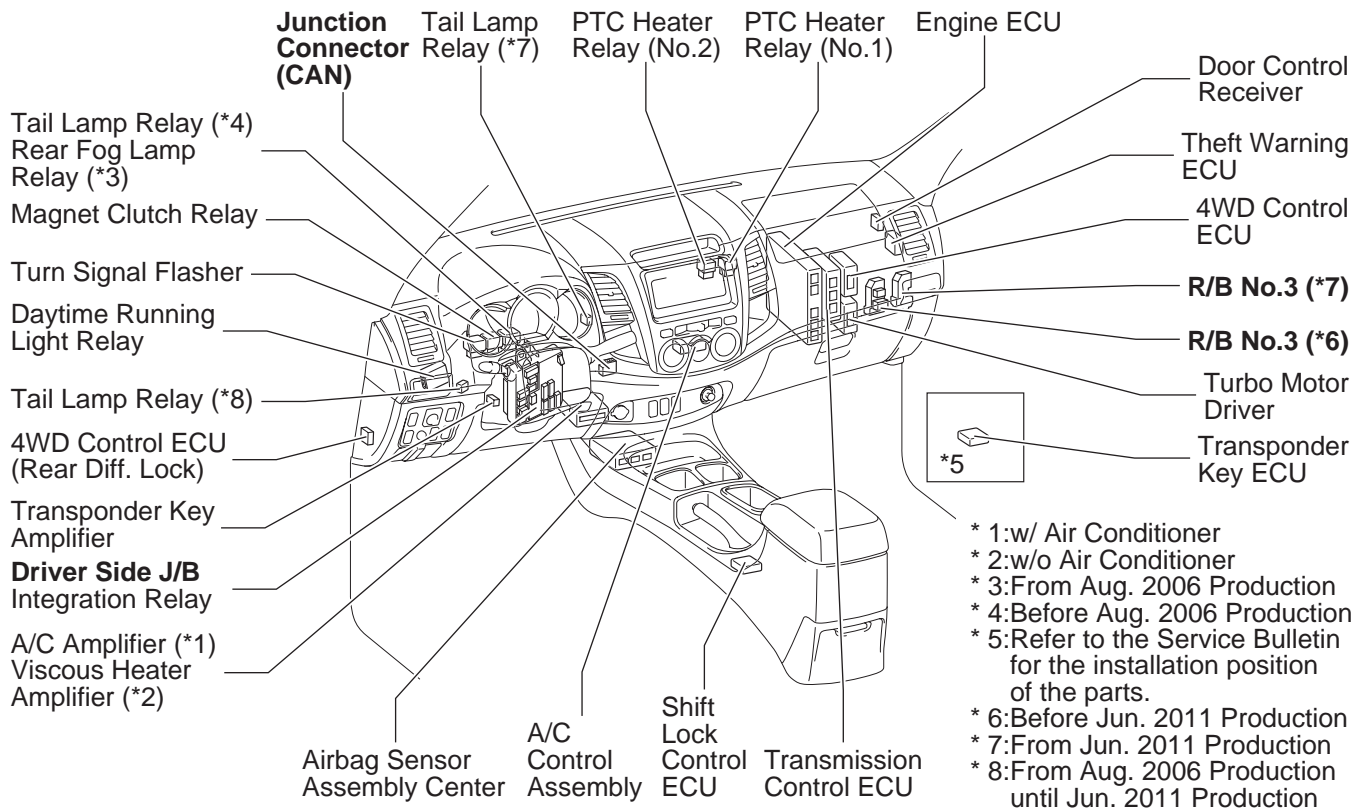

(RHD)

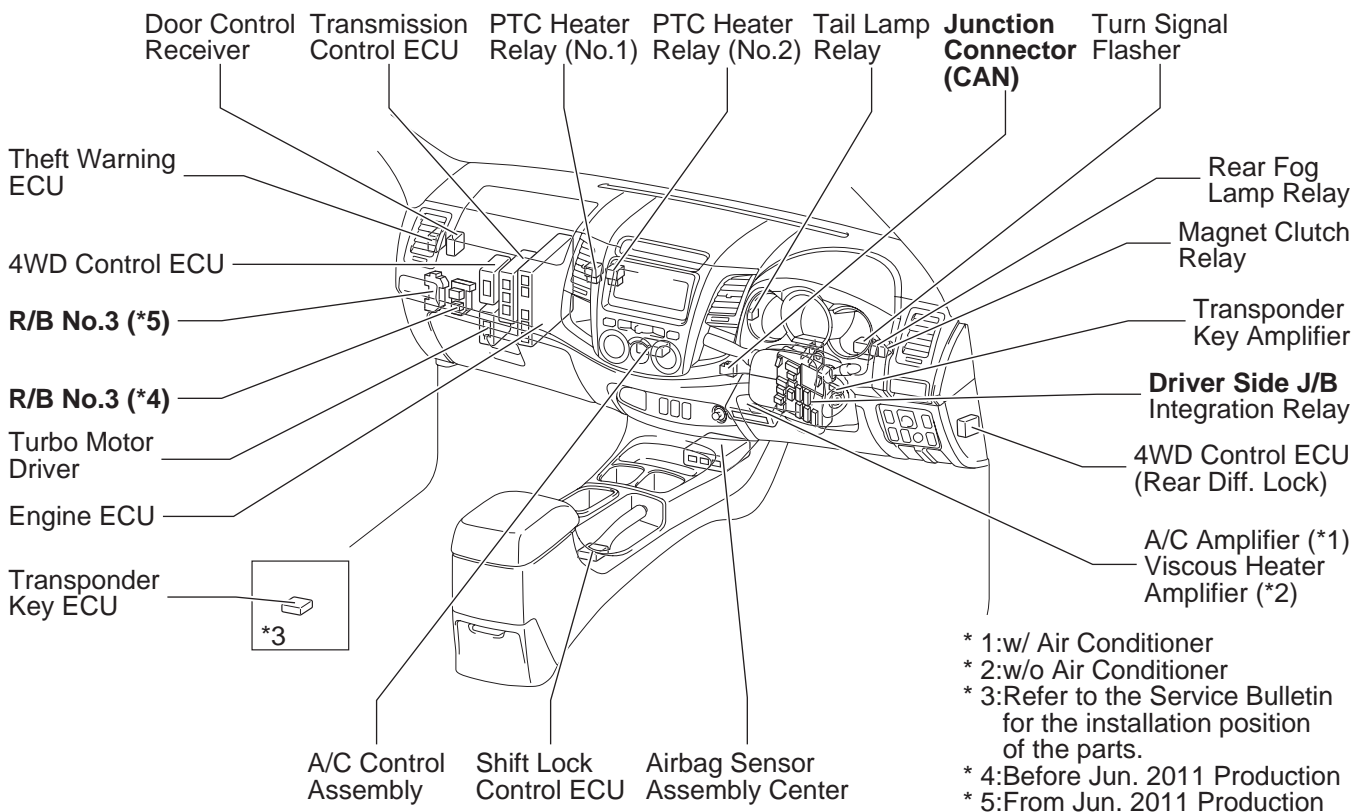

F RELAY LOCATIONS

Junction Connector (CAN)	LHD : Instrument Panel Brace LH (See Page 21)
	RHD : Instrument Panel Brace RH (See Page 21)

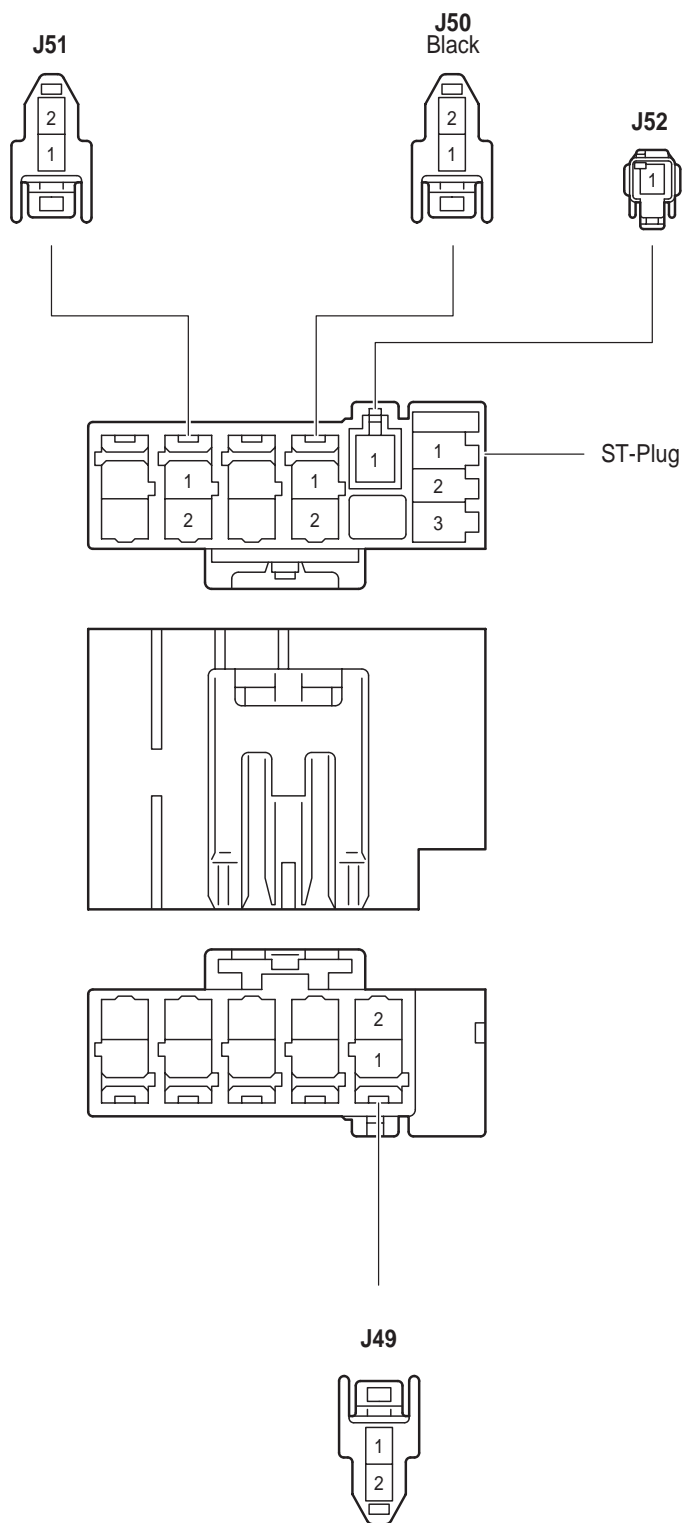

cardiagn.com

[Junction Connector (CAN) Inner Circuit]

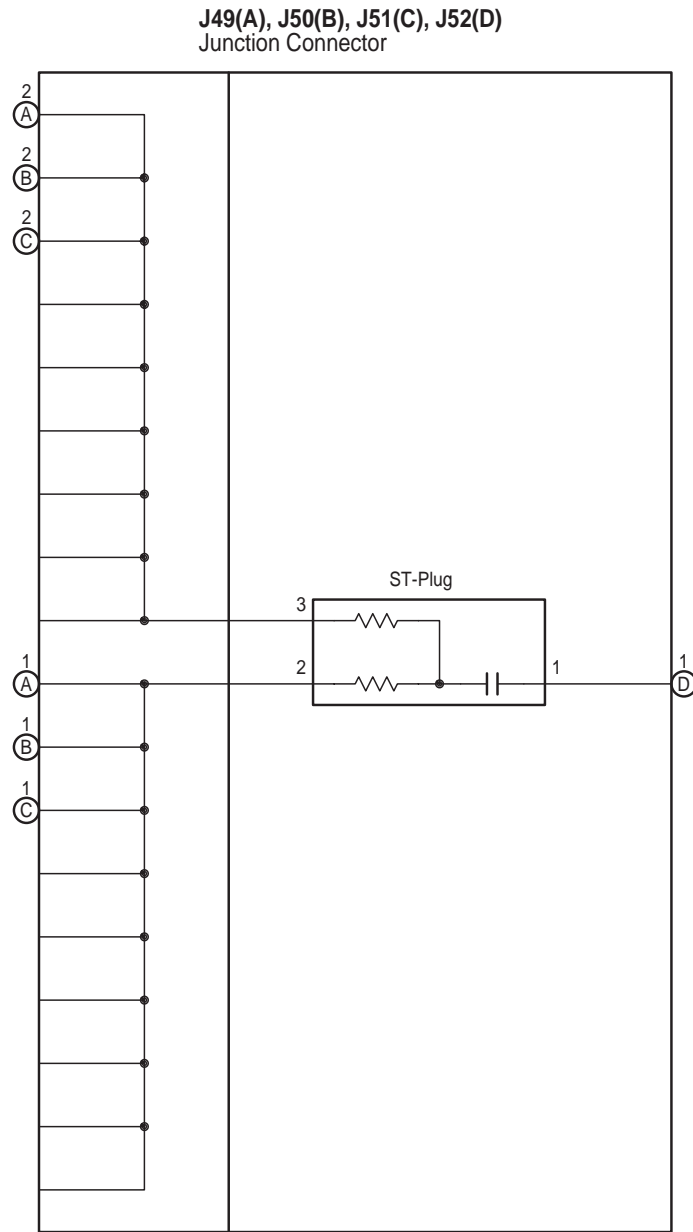

F RELAY LOCATIONS

③ : R/B No.3	LHD : Cowl Side Panel RH (See Page 21)
	RHD : Cowl Side Panel LH (See Page 21)

(Before Jun. 2011 Production)

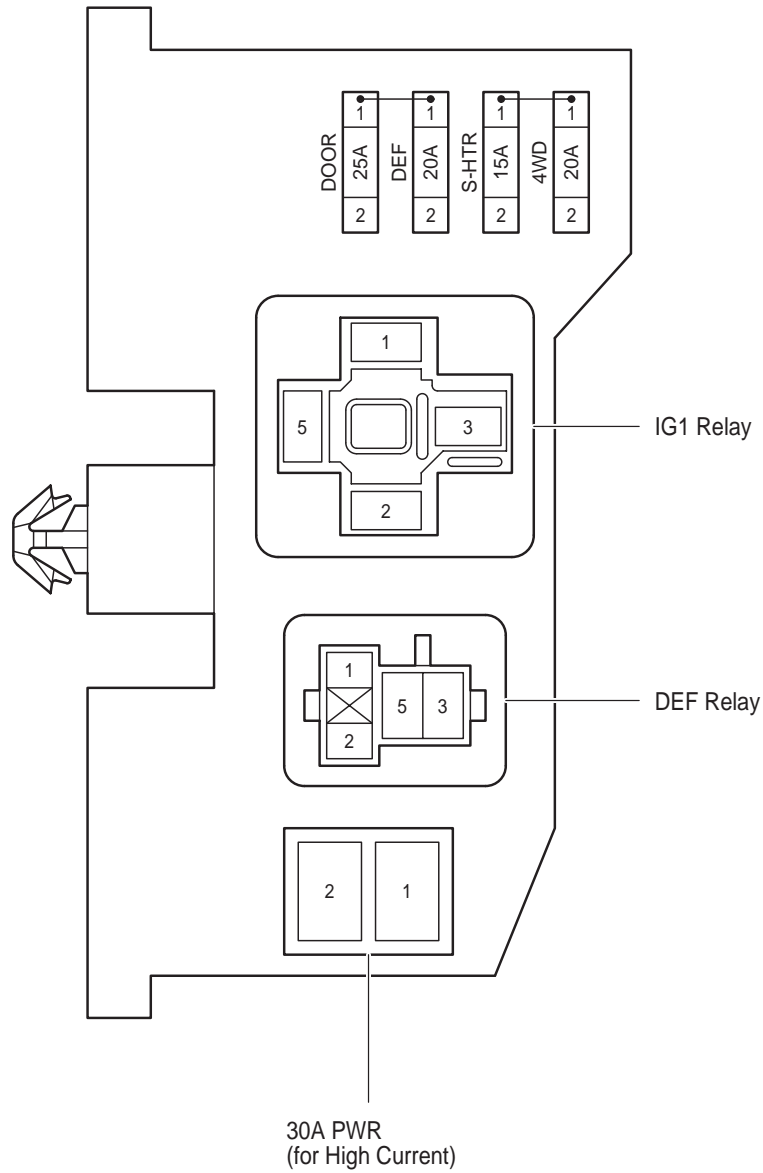

cardiagn.com

(From Jun. 2011 Production)

- * 1:15A MIR HTR (*6)
25A DOOR (*7)
- * 2:25A DOOR (*6)
20A DEF (*7)
- * 3:20A DEF (*6)
15A S-HTR (*7)
- * 4:15A S-HTR (*6)
20A 4WD (*7)
- * 5:20A 4WD (*6)
15A MIR HTR (*7)
- * 6:Before Nov. 2011 Production
- * 7:From Nov. 2011 Production

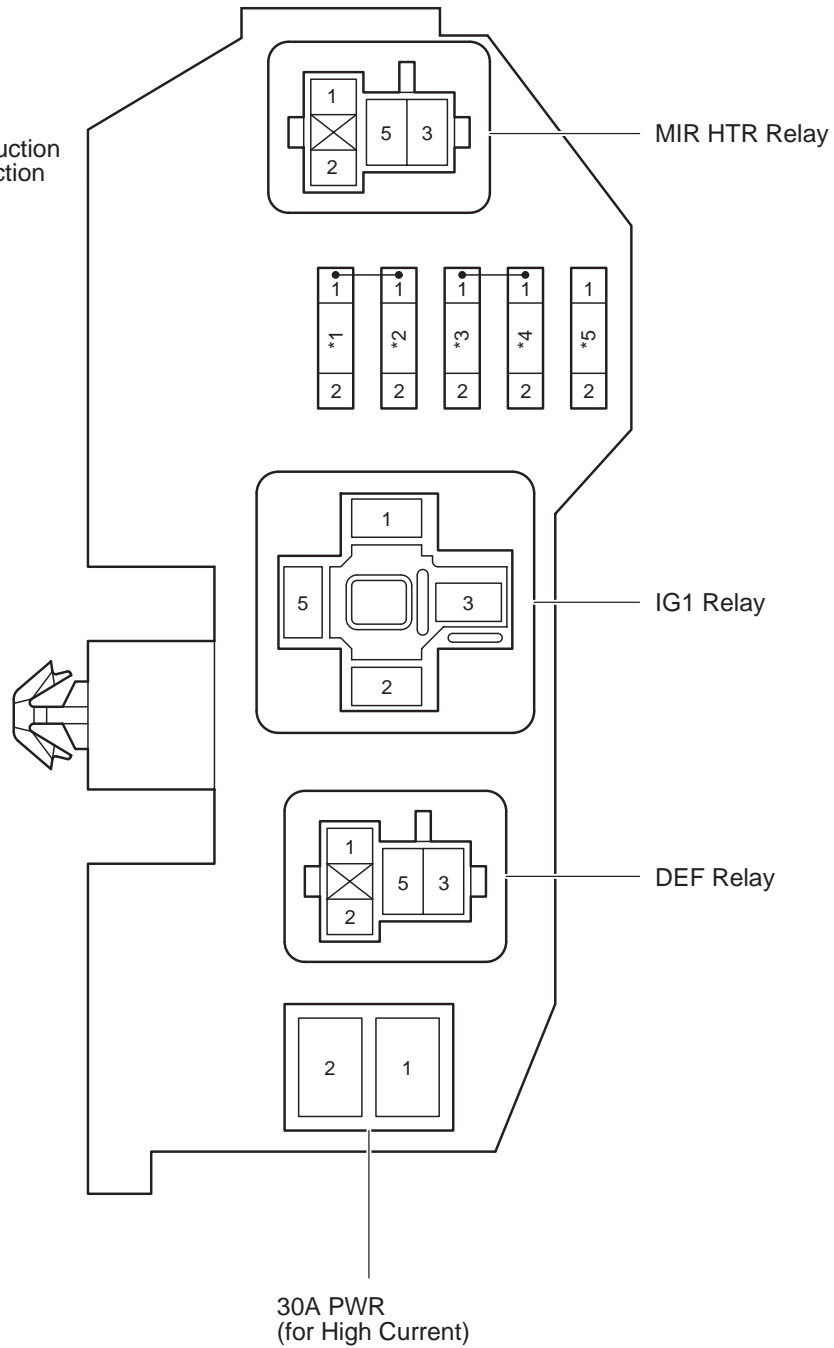

cardiagn.com