

## POWER STEERING

### On-Vehicle Inspection

#### CHECK OF DRIVE BELT TENSION (RU series only)

Measure the drive belt deflection.

Drive belt deflection: at 10 kg (22.0 lb, 98 N)

New belt 4.8 – 6.0 mm (0.189 – 0.236 in.)

Used belt 6.0 – 8.0 mm (0.236 – 0.315 in.)

(Reference)

Using SST, check the drive belt tension.

SST 09216-00020 and 09216-00030

Drive belt tension:

New belt 40 – 60 kg

Used belt 20 – 40 kg

NOTE:

- "New belt" refers to a brand new belt which has never before been used.
- "Used belt" refers to a belt which has been used on a running engine for 5 minutes or more.

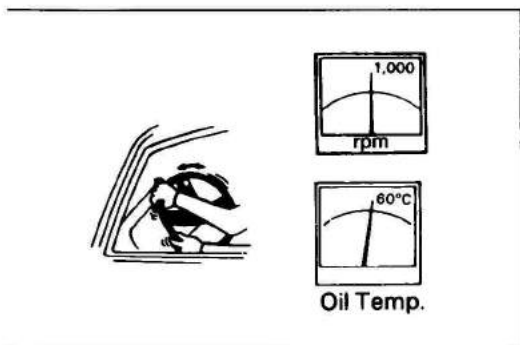
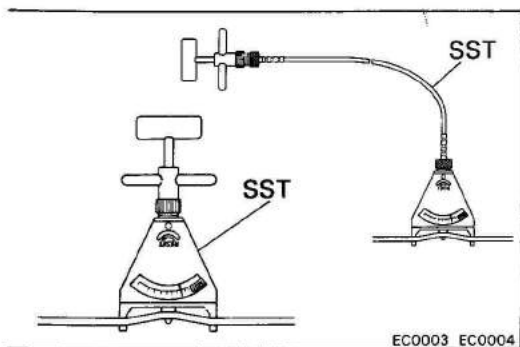

#### FLUID LEVEL CHECK

##### 1. KEEP VEHICLE LEVEL

##### 2. BOOST FLUID TEMPERATURE

With the engine idling at 1,000 rpm or less, turn the steering wheel from lock to lock several times to boost the fluid temperature.

Fluid temperature: 60°C (140°F)

##### 3. CHECK FOR FOAMING OR EMULSIFICATION

NOTE: Foaming or emulsification indicate the existence of air in the system or that the fluid level is too low.

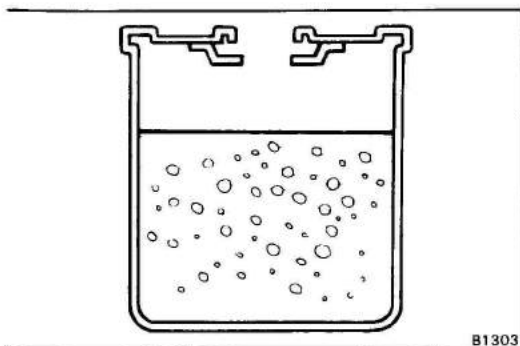

##### 4. CHECK FLUID LEVEL IN RESERVOIR

Stop the engine and check that the fluid is within the HOT LEVEL of the dipstick.

Fluid: ATF DEXRON or DEXRON II

NOTE: If the fluid is cold, it should be within the COLD LEVEL of the dipstick.

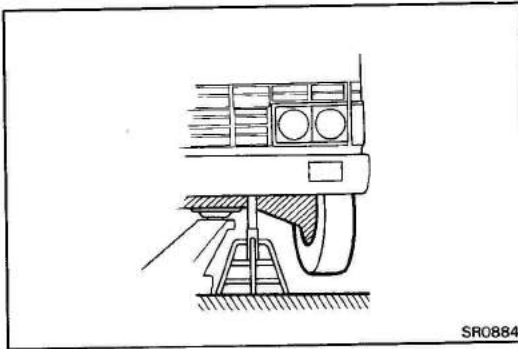

**REPLACEMENT OF POWER STEERING FLUID**

1. JACK UP FRONT OF VEHICLE AND SUPPORT IT WITH STANDS

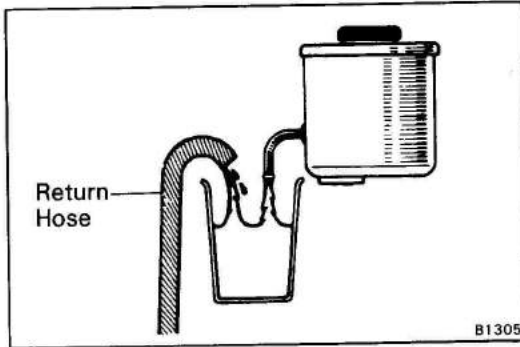

2. REMOVE FLUID RETURN HOSE FROM RESERVOIR TANK AND DRAIN FLUID INTO CONTAINER

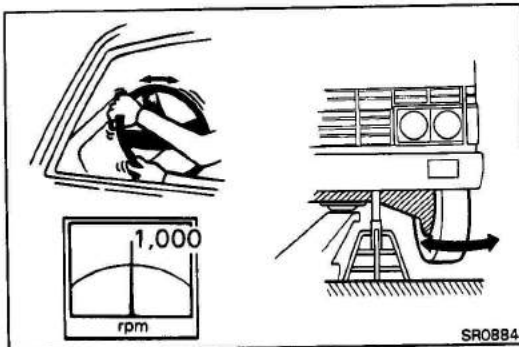

3. WITH ENGINE IDLING, TURN STEERING WHEEL FROM FULL LEFT TO FULL RIGHT WHILE DRAINING FLUID

4. STOP ENGINE

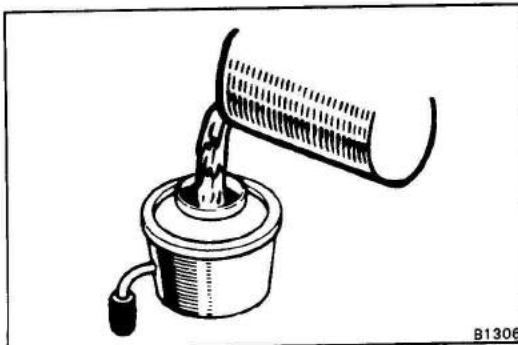

5. FILL RESERVOIR WITH FRESH FLUID  
Fluid: ATF DEXRON or DEXRON II

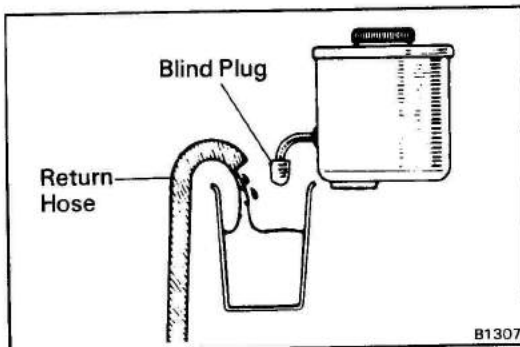

6. START ENGINE AND RUN IT AT 1,000 RPM  
After 1 or 2 seconds, fluid will begin to discharge from the return hose. Stop the engine immediately at this time.
7. REPEAT STEPS 5 AND 6 FOUR OR FIVE TIMES UNTIL THERE IS NO MORE AIR IN FLUID
8. CONNECT RETURN HOSE TO RESERVOIR TANK
9. BLEED POWER STEERING SYSTEM

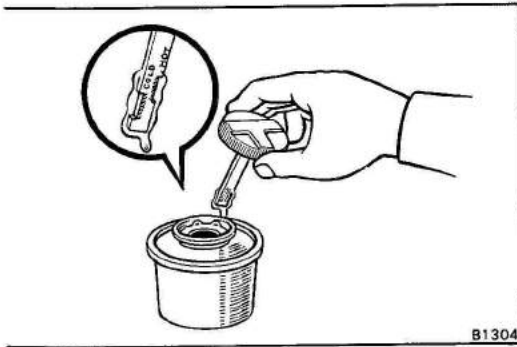

B1304

## Bleeding of Power Steering System

### 1. CHECK FLUID LEVEL IN RESERVOIR

Check the fluid level and add fluid if necessary.

**Fluid: ATF DEXRON or DEXRON II**

**NOTE:** Check that the fluid level is within the **HOT LEVEL** of the dipstick. If the fluid is cold, check that it is within the **COLD LEVEL** of the dipstick.

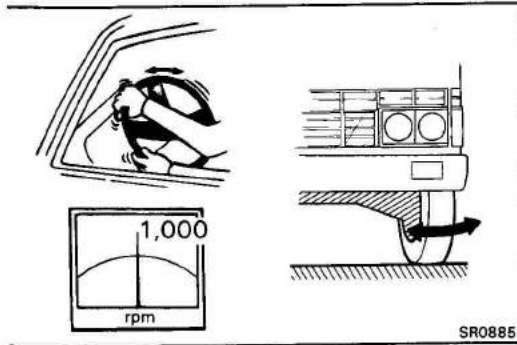

SR0885

### 2. START ENGINE AND TURN STEERING WHEEL FROM LOCK TO LOCK THREE OR FOUR TIMES

Run the engine at 1,000 rpm or less.

**NOTE:** Do not keep the steering wheel more than 10 seconds at locked position.

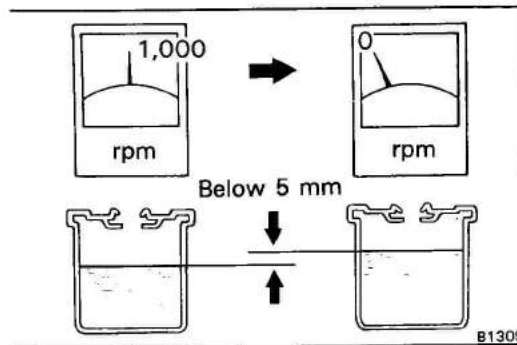

B1309

### 3. CHECK THAT FLUID IN RESERVOIR IS NOT FOAMY OR CLOUDY AND DOES NOT RISE OVER MAXIMUM WHEN ENGINE IS STOPPED

Measure the fluid level with the engine running. Stop the engine and measure the fluid level.

**Maximum rise: 5 mm (0.20 in.)**

If a problem is found, repeat steps 7 and 8 on page SR-30. Repair the PS pump if the problem persists.

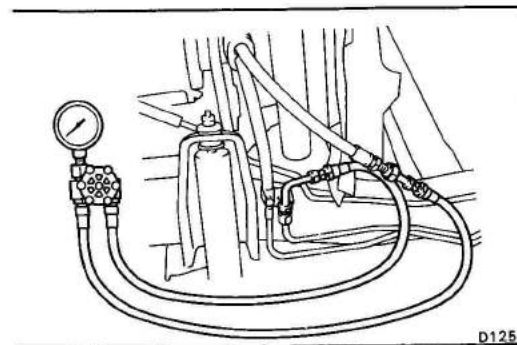

D1252

## Oil Pressure Check

### 1. INSTALL PRESSURE GAUGE

- Disconnect the pressure line.
- Connect the gauge side of the pressure gauge to the PS pump side.
- Connect the valve side of the pressure gauge to the steering gear housing side.
- Bleed the system.

### 2. CHECK THAT FLUID TEMPERATURE IS AT LEAST 60°C (140°F)

### 3. START ENGINE AND RUN IT AT IDLE

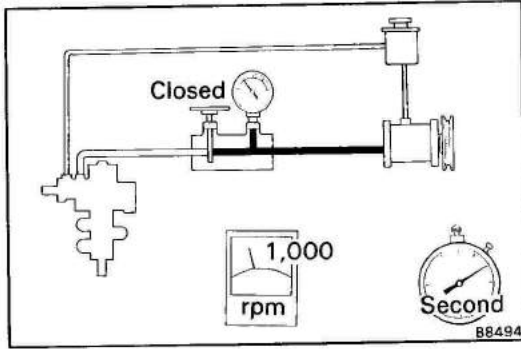

Pressure Differential  
Less than 5 kg/cm<sup>2</sup>

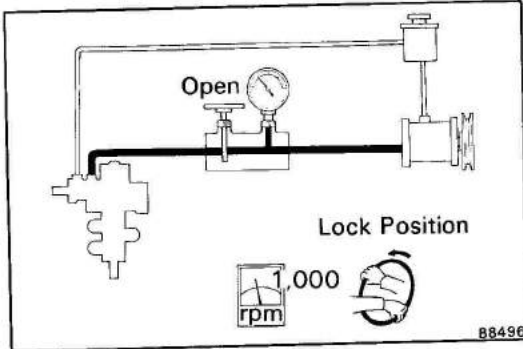
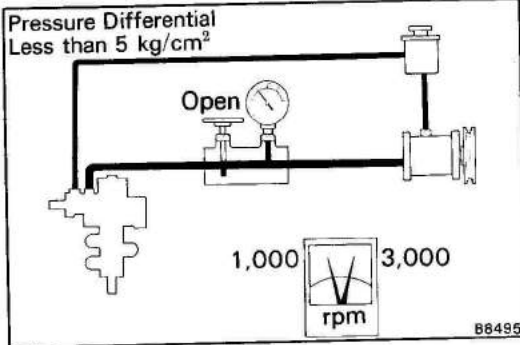

4. **CHECK PRESSURE READING WITH VALVE CLOSED**  
Close the pressure gauge valve and observe the reading on the gauge.

Pressure:

BU series	Regular Cab	58 kg/cm <sup>2</sup> (825 psi, 5,688 kPa)
	Wide Cab	70 ± 5 kg/cm <sup>2</sup> (996 ± 71 psi, 6,865 ± 490 kPa)
RU series		70 ± 5 kg/cm <sup>2</sup> (996 ± 71 psi, 6,865 ± 490 kPa)
WU series		75 ± 5 kg/cm <sup>2</sup> (1,067 ± 71 psi, 7,355 ± 490 kPa)

**CAUTION:** Do not keep the valve closed for more than 10 seconds.

If pressure is low, repair or replace PS pump.

5. **OPEN VALVE FULLY**
6. **CHECK AND RECORD PRESSURE READING AT 1,000 RPM**
7. **CHECK AND RECORD PRESSURE READING AT 3,000 RPM**

Check that there is less than 5 kg/cm<sup>2</sup> (71 psi, 490 kPa) difference in pressure between the 1,000 rpm and 3,000 rpm checks.

If the difference is greater, repair or replace the PS pump flow control valve.

8. **CHECK PRESSURE READING WITH STEERING WHEEL TURNED TO FULL LOCK**

Be sure the pressure gauge valve is fully opened and the engine idling.

Pressure:

BU series	Regular Cab	58 kg/cm <sup>2</sup> (825 psi, 5,688 kPa)
	Wide Cab	70 ± 5 kg/cm <sup>2</sup> (996 ± 71 psi, 6,865 ± 490 kPa)
RU series		70 ± 5 kg/cm <sup>2</sup> (996 ± 71 psi, 6,865 ± 490 kPa)
WU series		75 ± 5 kg/cm <sup>2</sup> (1,067 ± 71 psi, 7,355 ± 490 kPa)

If pressure is low, the gear housing has an internal leak and must be repaired or replaced.

9. **MEASURE STEERING EFFORT**

Center the steering wheel and run the engine at idle.

Using a scale, measure the steering effort in both directions.

**Maximum steering effort: 9.0 kg (19.8 lb, 88 N)**

If steering effort is excessive, repair the power steering unit.

**NOTE:** Be sure to consider tire type, pressure and contact surface before making your diagnosis.

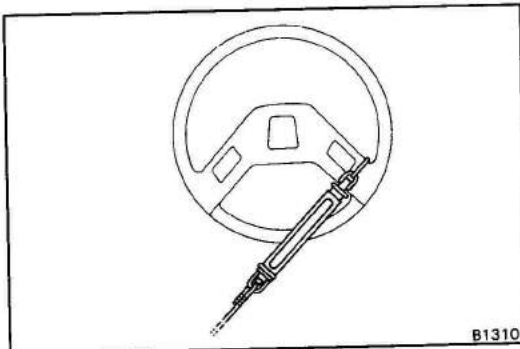

## Power Steering Pump

### REMOVAL OF POWER STEERING PUMP (RU series)

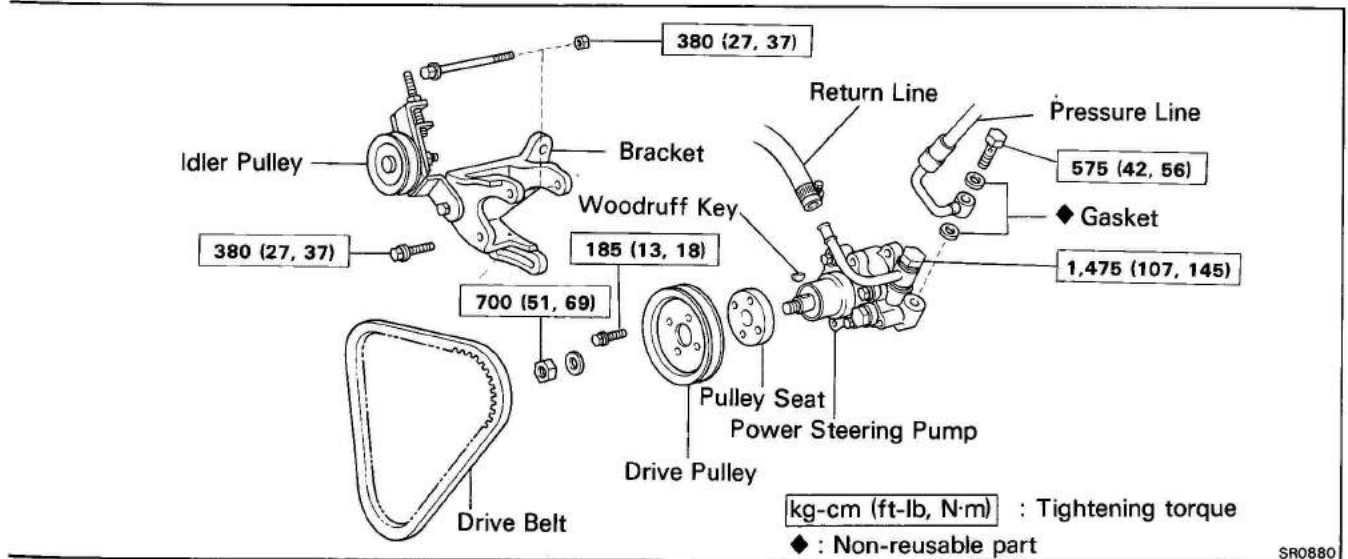

SR0880

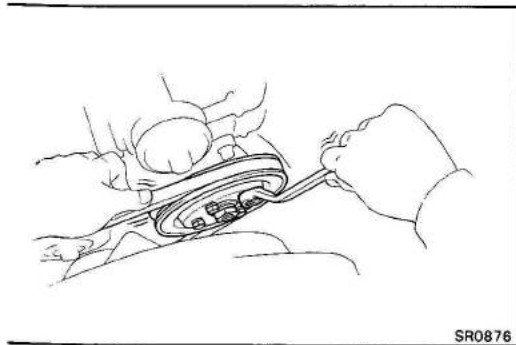

SR0876

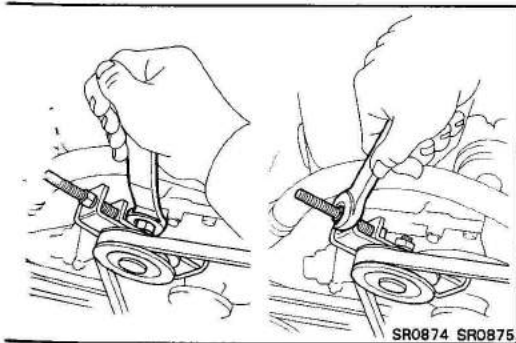

SR0874 SR0875

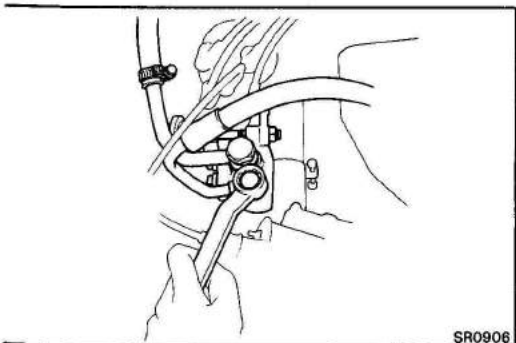

SR0906

#### 1. DRAW OUT FLUID FROM RESERVOIR TANK

#### 2. REMOVE DRIVE BELT AND PULLEY

- (a) Push on the drive belt to hold the pulley in place and loosen the pulley nut and bolts.

- (b) Loosen the idler pulley nut.

- (c) Loosen the adjusting nut and remove the drive belt.

- (d) Remove the drive pulley and woodruff key.

#### 3. DISCONNECT PRESSURE LINE

Loosen the union bolt and disconnect the pressure line.

#### 4. DISCONNECT RETURN LINE

Loosen the hose clamp and pull off the hose.

#### 5. REMOVE POWER STEERING PUMP

Remove the PS pump mount bolts and nut, and remove the PS pump from the bracket.

#### 6. REMOVE RETURN LINE UNION

## REMOVAL OF POWER STEERING PUMP (BU series)

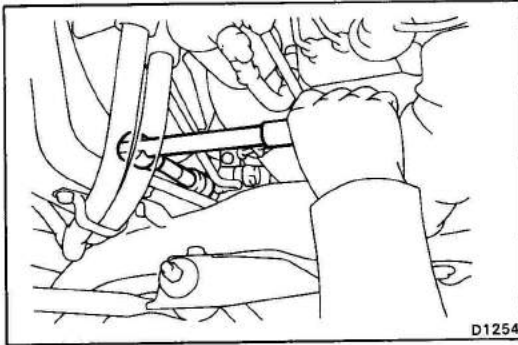
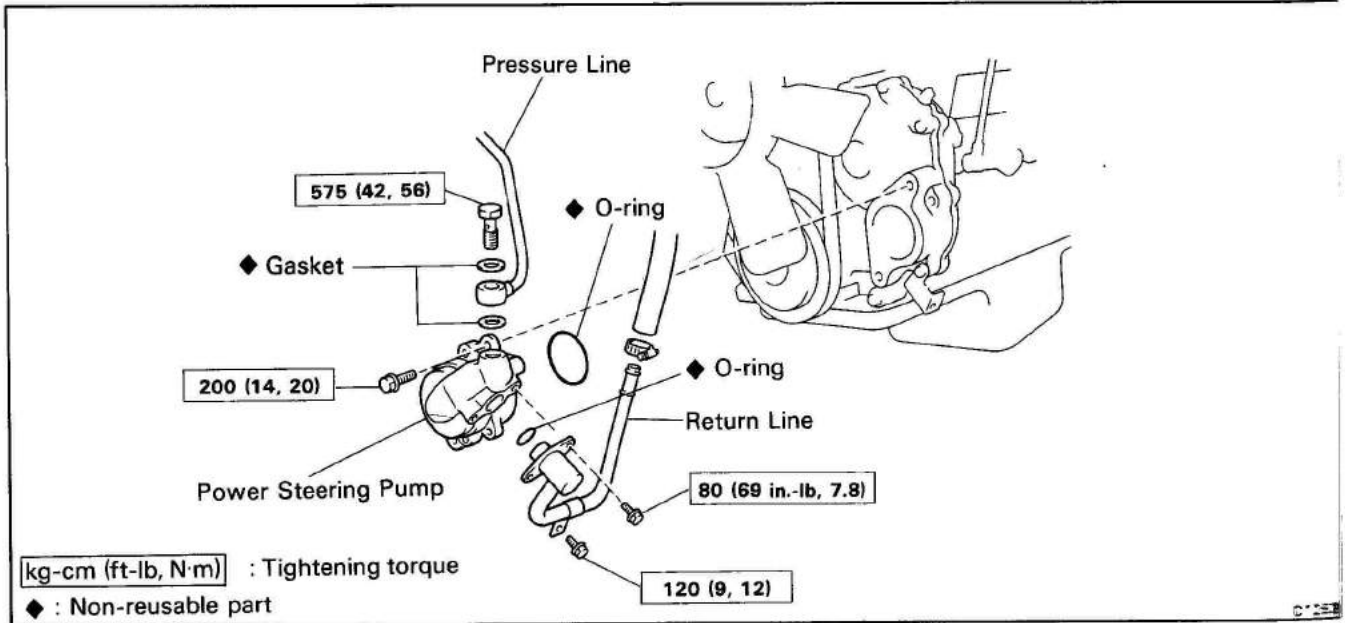

### 1. DRAW OUT FLUID FROM RESERVOIR TANK

### 2. DISCONNECT PRESSURE LINE

Loosen the union bolt and disconnect the pressure line

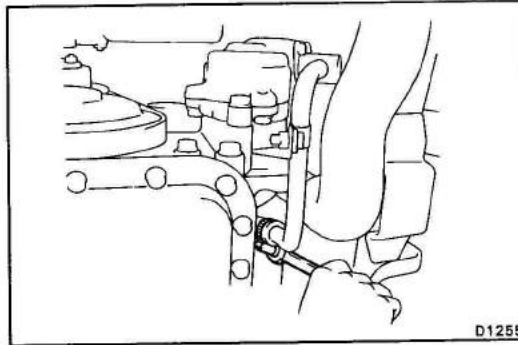

### 3. DISCONNECT RETURN LINE

Loosen the hose clamp and pull off the hose.

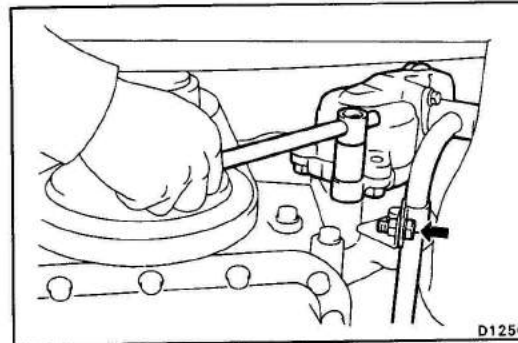

### 4. REMOVE POWER STEERING PUMP

- (a) Remove the union clamp bolt.
- (b) Remove the PS pump mount bolts, and remove the PS pump.

### 5. REMOVE UNION FROM POWER STEERING PUMP

## REMOVAL OF POWER STEERING PUMP (WU series)

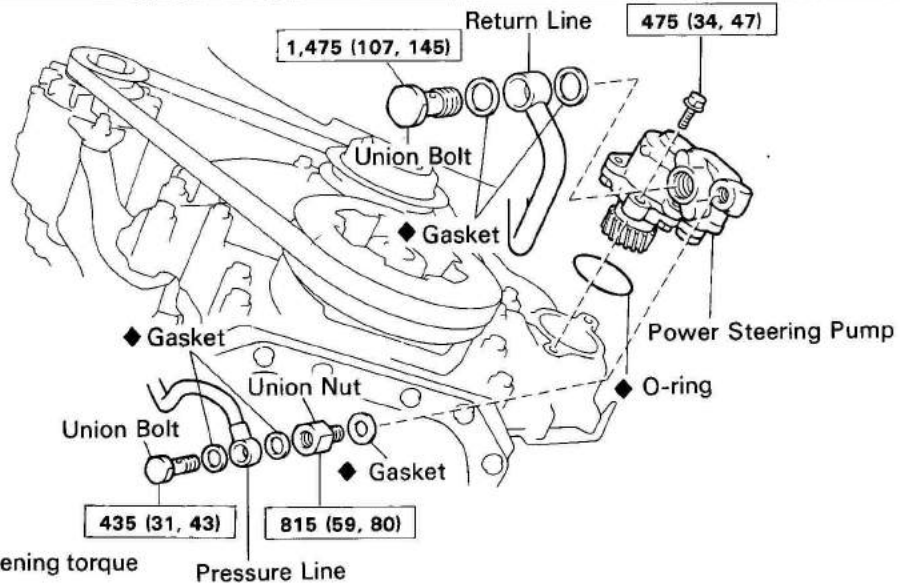

⊳g-cm (ft-lb, N·m) : Tightening torque

◆ : Non-reusable part

Pressure Line

D1257

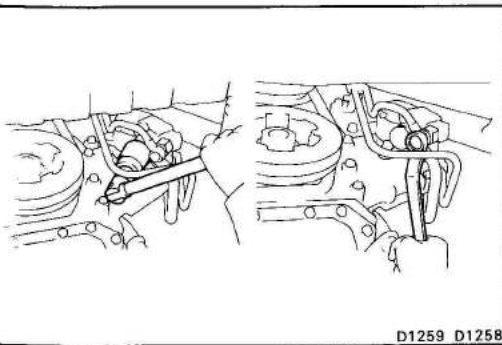

**1. DRAW OUT FLUID FROM RESERVOIR TANK**

**2. DISCONNECT PRESSURE LINE**

Loosen the union bolt and disconnect the pressure line.

**3. DISCONNECT RETURN LINE**

Loosen the union bolt and disconnect the return line.

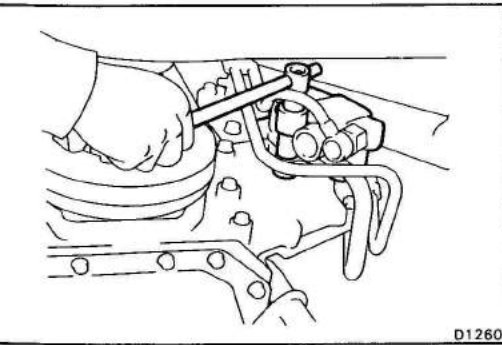

**4. REMOVE POWER STEERING PUMP**

Remove the PS pump mount bolts, and remove the PS pump.

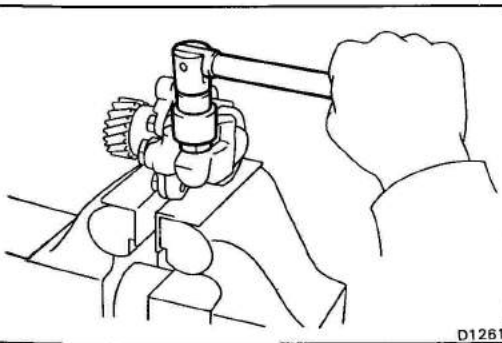

**5. REMOVE UNION NUT FROM POWER STEERING PUMP**

cardiagn.com

COMPONENTS

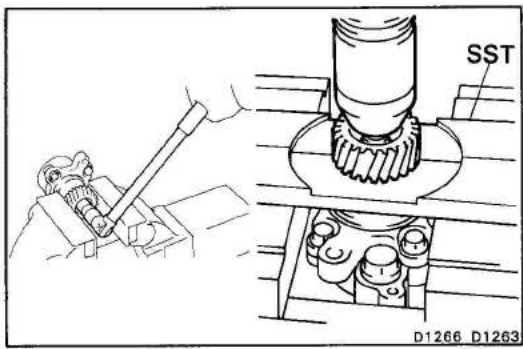
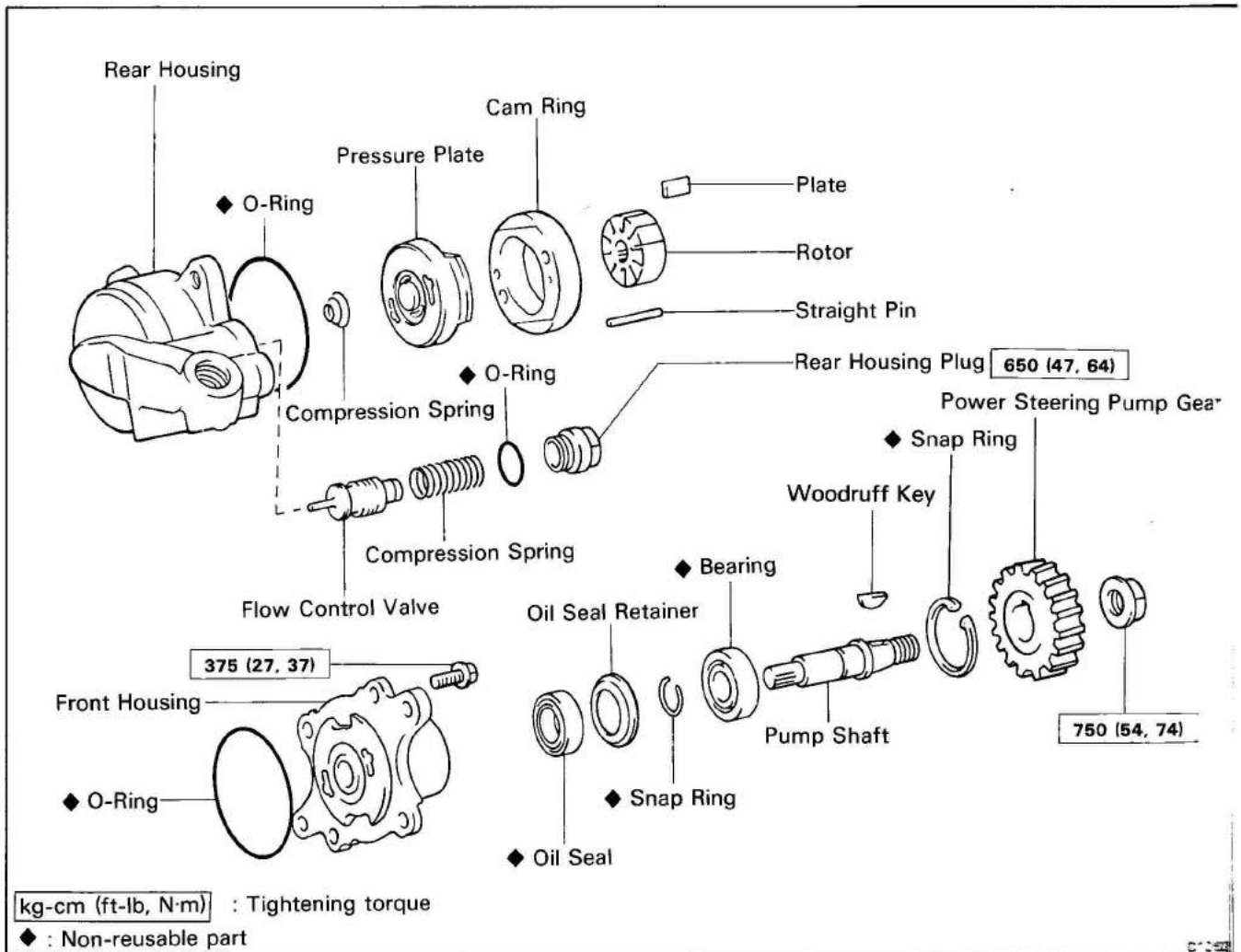

DISASSEMBLY OF POWER STEERING PUMP

1. (BU, WU series)  
**REMOVE POWER STEERING PUMP GEAR**
  - (a) Clamp the PS pump in vise.
  - CAUTION: Do not tighten the vise too tight.**
  - (b) Remove the gear nut.
  - (c) Using SST and a press, remove the gear from the drive shaft.
  - SST 09527-30010
  - (d) Remove the woodruff key.

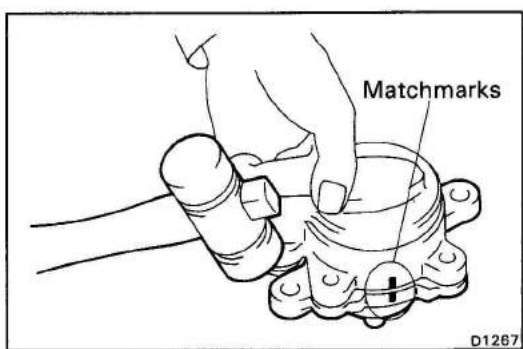

2. **REMOVE FRONT HOUSING**
  - (a) Place matchmarks on the front and rear housing
  - (b) Remove the four front housing bolts.
  - (c) Using a plastic hammer, tap off the front housing
  - CAUTION: Be careful that the vane plates, rotor and cam ring do not fall out.**
  - (d) Remove the O-ring.

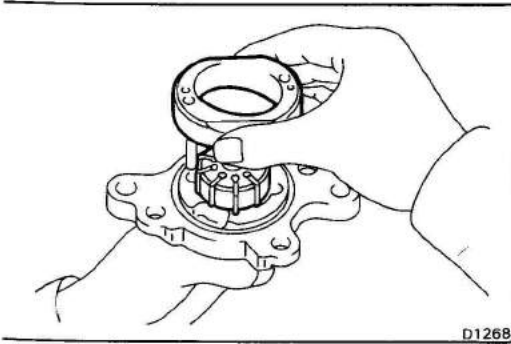

D1268

### 3. REMOVE CAM RING, ROTOR, VANE PLATES AND STRAIGHT PIN

**CAUTION:** Be careful not to scratch the cam ring, rotor, vane plates or straight pin.

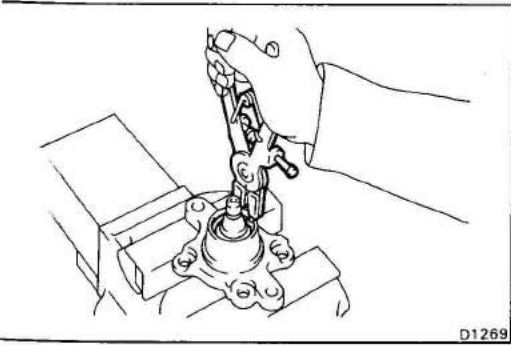

D1269

### 4. REMOVE ROTOR SHAFT

(a) Clamp the front housing in a vise.

**CAUTION:** Do not tighten the vise too tight.

(b) Using snap ring pliers, remove the snap ring.

(c) Using a press, remove the rotor shaft.

(d) Remove the oil seal retainer.

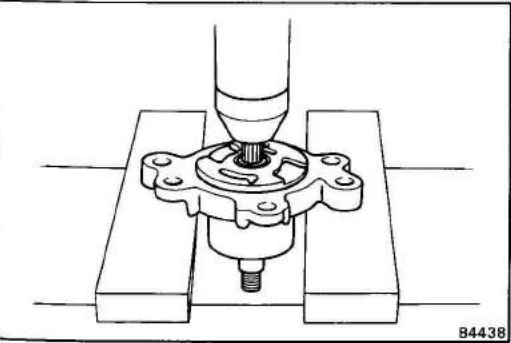

B4438

### 5. REMOVE OIL SEAL

(a) Clamp the front housing in a vise.

**CAUTION:** Do not tighten the vise too tight.

(b) Using a screwdriver and a hammer, tap out the oil seal.

**CAUTION:** Be careful not to scratch the housing.

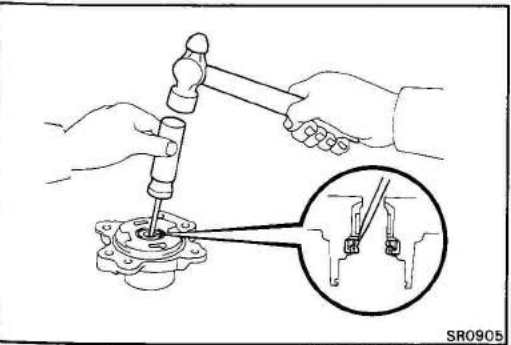

SR0905

### 6. REMOVE PRESSURE PLATE AND SPRING

(a) Using a plastic hammer, tap the bottom end of the rear housing, and remove the pressure plate and spring.

**CAUTION:** Avoid gripping the pressure plate with pliers as this could damage it.

(b) Remove the O-ring.

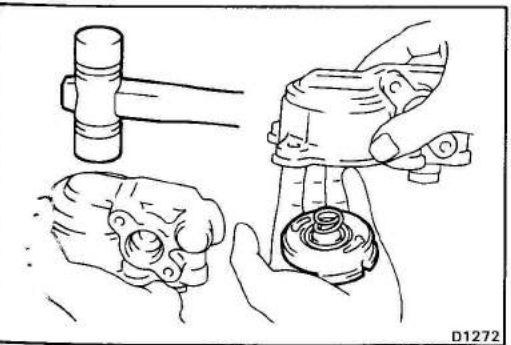

D1272

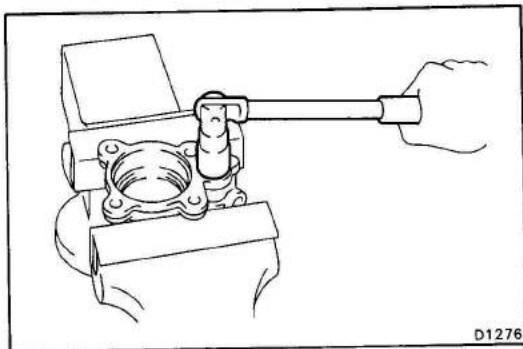

## 7. REMOVE FLOW CONTROL VALVE

(a) Remove the plug from the rear housing.

NOTE: Do not fly off the compression spring or plug when removing the plug.

(b) Remove the spring and flow control valve.

(c) Remove the O-ring from the plug.

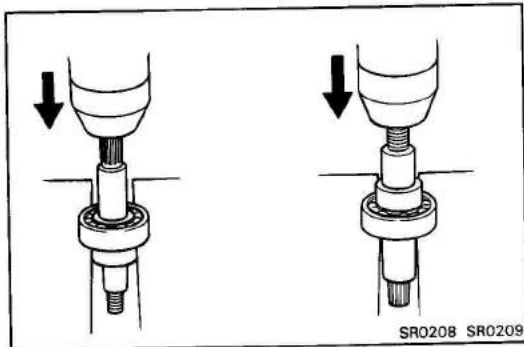

## 8. IF NECESSARY, REPLACE ROTOR SHAFT BEARING

(a) Using two screwdrivers, remove the snap ring.

(b) Using a press, press out the bearing.

(c) Using a press, press in the new bearing.

(d) Install the new snap ring.

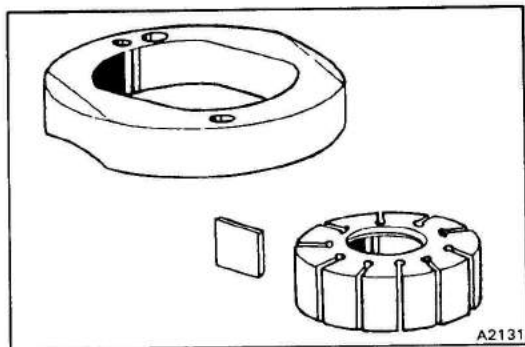

## INSPECTION OF POWER STEERING PUMP

### 1. INSPECT ROTOR, CAM RING AND VANE PLATES

Check the rotor, cam ring and vane plates for wear or damage.

If necessary, replace the rotor assembly with cam and vane.

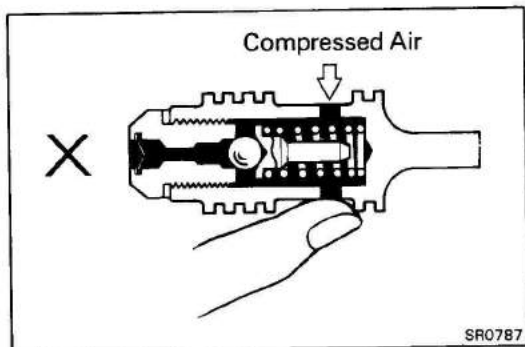

### 2. INSPECT FLOW CONTROL VALVE

(a) Check the flow control valve for wear or damage

(b) Apply fluid to the valve and check that it falls smoothly into the valve hole by its own weight.

(c) Check the flow control valve for leakage.

- Close one of the holes and apply compressed air [4 or 5 kg/cm<sup>2</sup> (57 or 71 psi, 392 or 490 kPa)] into the opposite side.

- Confirm that air does not come out from the end hole.

If necessary, select and replace valve for rear housing by matching cut marks and rear housing numbers as listed below.

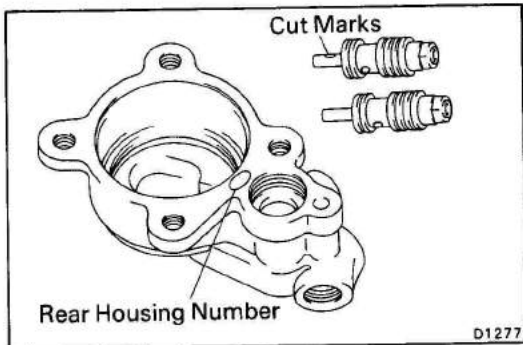

Rear Housing Number	Valve Cut Mark Numbers
0	Two
1	One
2	None

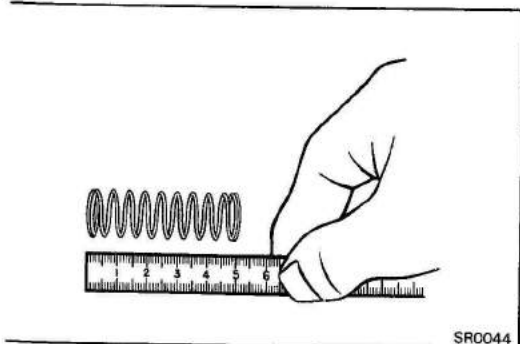

### 3. INSPECT FLOW CONTROL VALVE SPRING

Check that the spring is within specification.

**Spring length:**

**STD 55 mm (2.17 in.)**

**Limit 50 mm (1.97 in.)**

If the spring is not within specification, replace it.

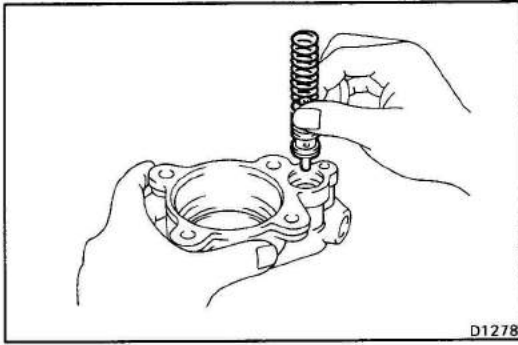

D1278

## ASSEMBLY OF POWER STEERING PUMP

(See page SR-36)

### 1. INSTALL FLOW CONTROL VALVE

- (a) Install the new O-ring to the plug.
- (b) Install the flow control valve.
- (c) Install the plug to the rear housing.

Torque: 650 kg-cm (47 ft-lb, 64 N·m)

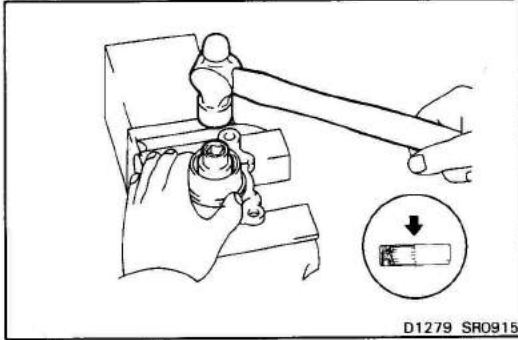

D1279 SR0915

### 2. INSTALL OIL SEAL

- (a) Apply a light coat of MP grease to the oil seal lip.
- (b) Using a socket wrench and hammer, install the oil seal.

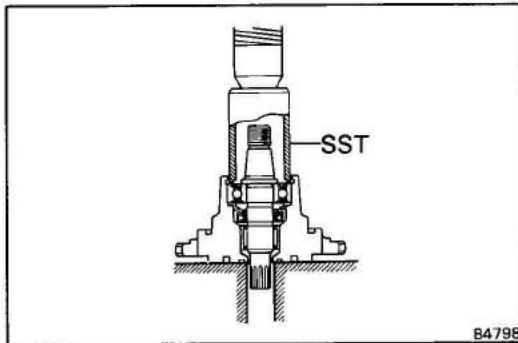

B4798

### 3. INSTALL ROTOR SHAFT TO FRONT HOUSING

- (a) Install the oil seal retainer.
- (b) Using SST and a press, install the rotor shaft into front housing.

SST 09632-36010

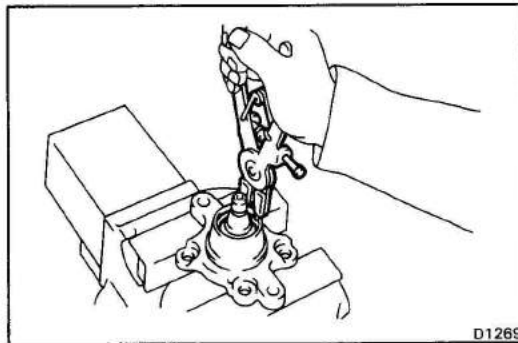

D1269

### 4. INSTALL SNAP RING

Using snap ring pliers, install the snap ring to the front housing.

### 5. INSTALL O-RING TO FRONT HOUSING

Install the new O-ring to the front housing.

### 6. INSTALL STRAIGHT PIN

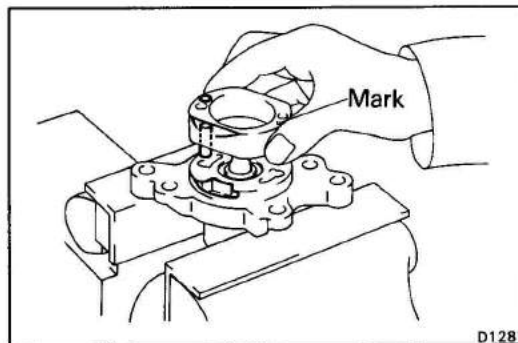

D1281

### 7. INSTALL CAM RING

Align the fluid passages of the cam ring and front housing and install the cam ring.

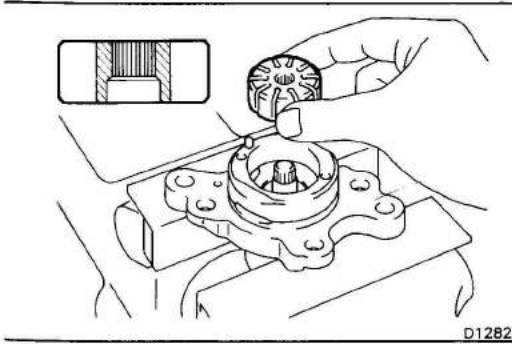
**8. INSTALL ROTOR**

Install the rotor with the chamfered end facing toward the front.

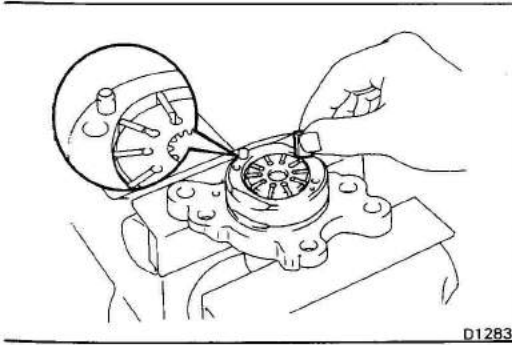
**9. INSTALL VANE PLATES**

Install the vane plates with the round end facing outward.

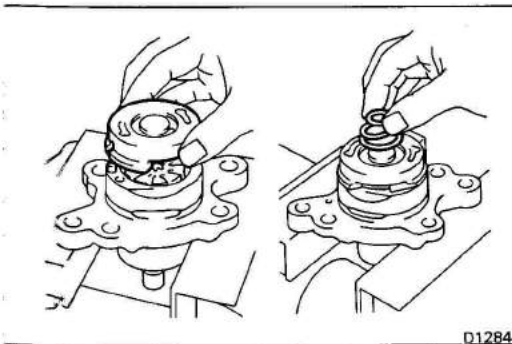
**10. INSTALL PRESSURE PLATE AND SPRING**

(a) Align the fluid passages of the pressure plate and cam ring, and install the pressure plate.

NOTE: When installing the pressure plate to cam ring, align the pressure plate notch and straight pin.

(b) Place the spring on the pressure plate.

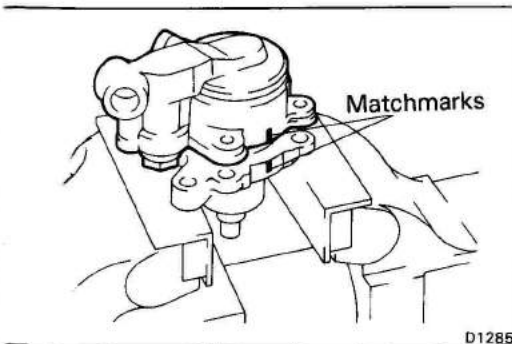
**11. INSTALL REAR HOUSING**

(a) Align the matchmarks on the front and rear housing, and assemble them.

(b) Tighten the front and rear housing mounting bolts by hand.

**12. TIGHTEN FOUR HOUSING BOLTS**

(a) Clamp the rear housing in a vise.

**CAUTION: Do not tighten the vise too tight.**

(b) Tighten the four housing bolts evenly in 3 or 4 passes.

**Torque: 375 kg-cm (27 ft-lb, 37 N·m)**

**13. CHECK ROTOR SHAFT ROTATION CONDITION**

(a) Check that rotor shaft rotates smoothly without abnormal noise.

(b) Provisionally install the nut and check the rotating torque.

**Rotating torque: Less than 2 kg-cm  
(1.7 in.-lb, 0.2 N·m)**

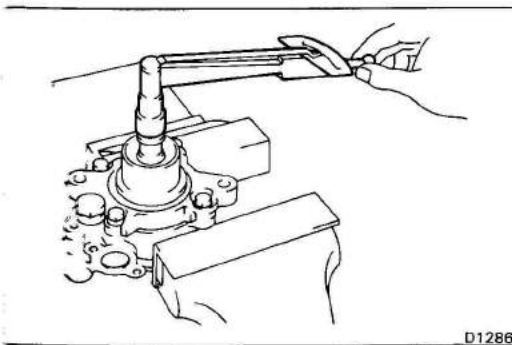

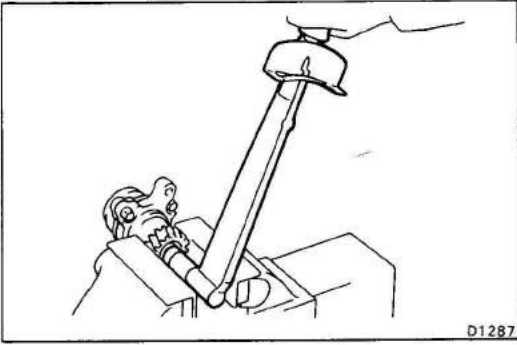

**14. (BU, WU series)  
INSTALL POWER STEERING PUMP GEAR**

- (a) Install the woodruff key to the shaft.
- (b) Install the gear.
- (c) Tighten the gear nut.

**Torque: 750 kg-cm (54 ft-lb, 74 N·m)**

**NOTE:** Use soft jaws on the vise when clamping the gear in a vise.

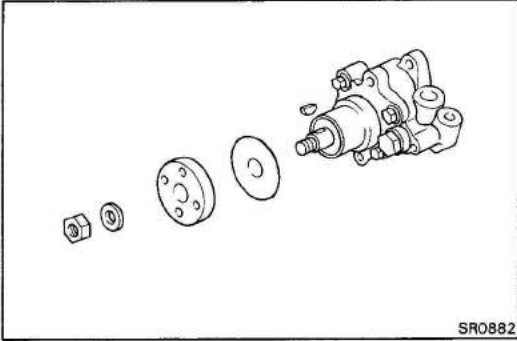

**15. (RU series)  
INSTALL BEARING COVER, WOODRUFF KEY AND  
PULLEY SEAT**

- (a) Install the bearing cover, woodruff key and pulley seat to the PS pump.
- (b) Tighten the pulley nut over the wave washer.

**Torque: 700 kg-cm (51 ft-lb, 69 N·m)**

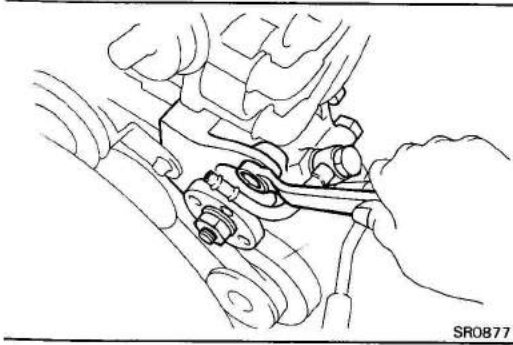

## INSTALLATION OF POWER STEERING PUMP (RU series)

### 1. INSTALL POWER STEERING PUMP

Place the PS pump in position and torque the mounting bolts.

**Torque: 380 kg-cm (27 ft-lb, 37 N·m)**

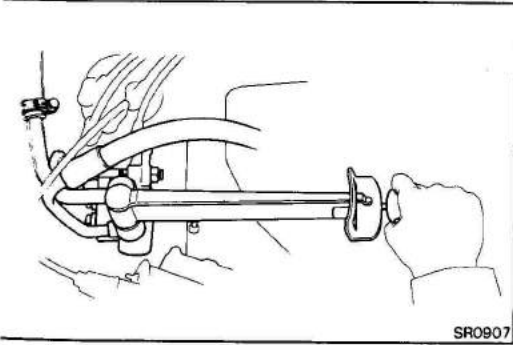

### 2. CONNECT RETURN LINE

Align the marks and connect the return line union over the gaskets and tighten the union bolt.

**Torque: 1,475 kg-cm (107 ft-lb, 145 N·m)**

### 3. CONNECT PRESSURE LINE

Align the marks and connect the pressure line union over the gaskets and tighten the union bolt.

**Torque: 575 kg-cm (42 ft-lb, 56 N·m)**

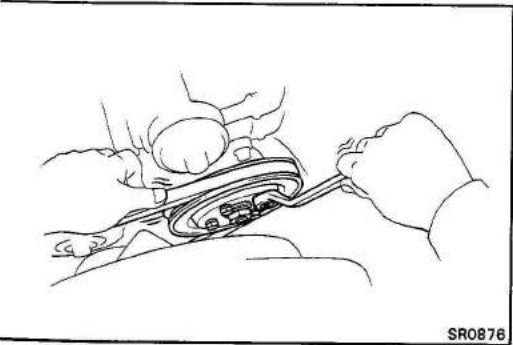

### 4. INSTALL DRIVE PULLEY AND BELT

(a) Install the pulley.

(b) Push down on the drive belt to hold the pulley in place and torque the pulley set bolts.

**Torque: 185 kg-cm (13 ft-lb, 18 N·m)**

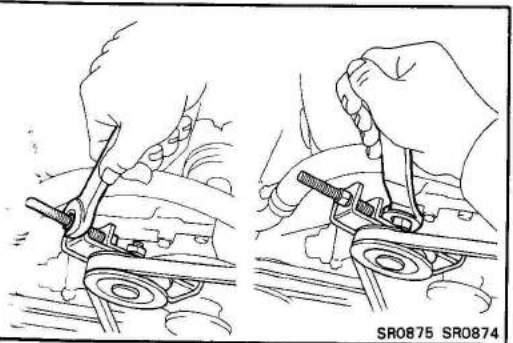

### 5. ADJUST DRIVE BELT TENSION (See page SR-29)

(a) Turn the adjusting bolt until the belt tension is at specified value.

(b) Tighten the idler pulley nut and adjusting bolt.

### 6. FILL RESERVOIR WITH FLUID

**Fluid: ATF DEXRON or DEXRON II**

### 7. BLEED POWER STEERING SYSTEM (See page SR-31)

### 8. PERFORM PRESSURE CHECK (See page SR-31)

### 9. CHECK FOR FLUID LEAKS

### 10. CHECK FLUID LEVEL (See page SR-29)

## INSTALLATION OF POWER STEERING PUMP (BU series)

### 1. INSTALL UNION TO POWER STEERING PUMP

- (a) Install the new O-ring to the union.
- (b) Install the union to the PS pump.

**Torque: 80 kg-cm (69 in.-lb, 7.8 N·m)**

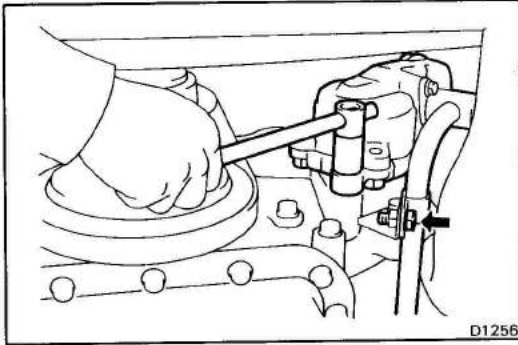

### 2. INSTALL POWER STEERING PUMP

- (a) Install the new O-ring to the PS pump.
- (b) Place the PS pump in position and torque the mounting bolts.

**Torque: 200 kg-cm (14 ft-lb, 20 N·m)**

- (c) Tighten the union clamp bolt.

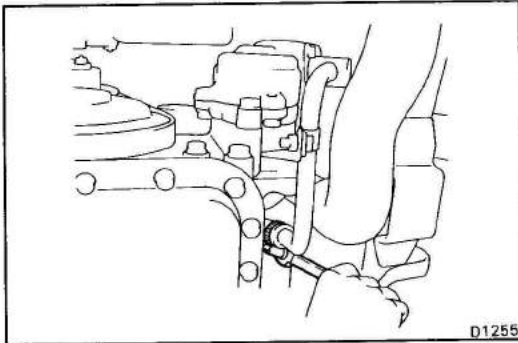

### 3. CONNECT RETURN LINE

Push on the hose fitting and tighten the clamp.

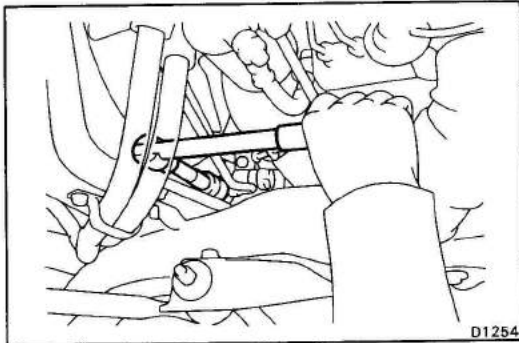

### 4. CONNECT PRESSURE LINE

Connect the pressure line union over the gaskets and tighten the union bolt.

**Torque: 575 kg-cm (42 ft-lb, 56 N·m)**

### 5. FILL RESERVOIR WITH FLUID

**Fluid: ATF DEXRON or DEXRON II**

### 6. BLEED POWER STEERING SYSTEM (See page SR-31)

### 7. PERFORM PRESSURE CHECK (See page SR-31)

### 8. CHECK FOR FLUID LEAKS

### 9. CHECK FLUID LEVEL (See page SR-29)

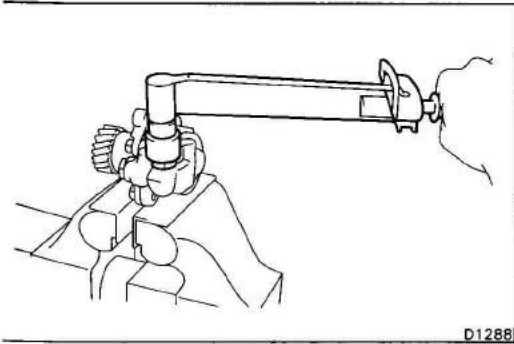

D1288

## INSTALLATION OF POWER STEERING PUMP (WU series)

1. **INSTALL UNION NUT TO POWER STEERING PUMP**  
Install the union nut to the PS pump through the new gasket.

**Torque: 815 kg-cm (59 ft-lb, 80 N·m)**

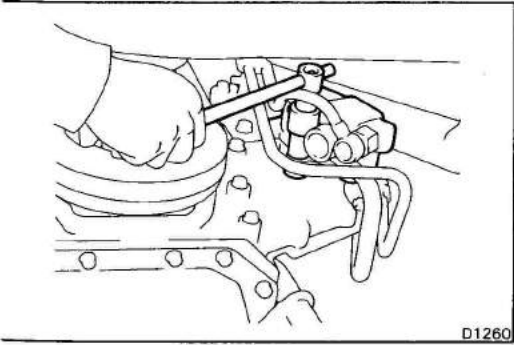

D1260

2. **INSTALL POWER STEERING PUMP**

- (a) Install the new O-ring to the PS pump.
- (b) Place the PS pump in position and torque the mounting bolts.

**Torque: 475 kg-cm (34 ft-lb, 47 N·m)**

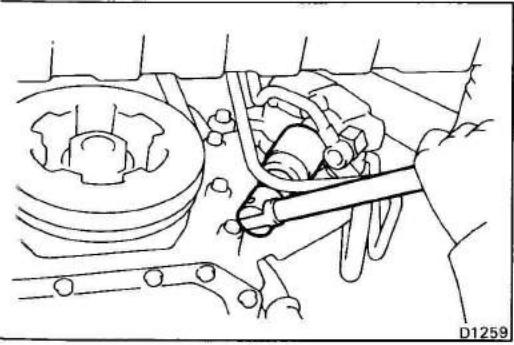

D1259

3. **CONNECT RETURN LINE**

Connect the return line union over the gaskets and tighten the union bolt.

**Torque: 1,475 kg-cm (107 ft-lb, 145 N·m)**

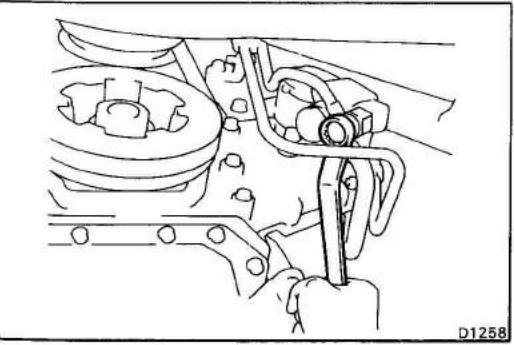

D1258

4. **CONNECT PRESSURE LINE**

Connect the pressure line union over the gaskets and tighten the union bolt.

**Torque: 435 kg-cm (31 ft-lb, 43 N·m)**

5. **FILL RESERVOIR WITH FLUID**

Fluid: ATF DEXRON or DEXRON II

6. **BLEED POWER STEERING SYSTEM (See page SR-31)**

7. **PERFORM PRESSURE CHECK (See page SR-31)**

8. **CHECK FOR FLUID LEAKS**

9. **CHECK FLUID LEVEL (See page SR-29)**

# Gear Housing

## REMOVAL OF GEAR HOUSING

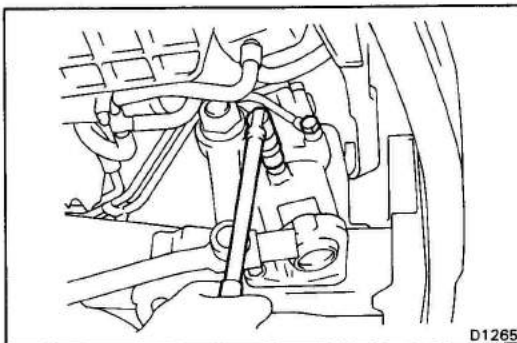
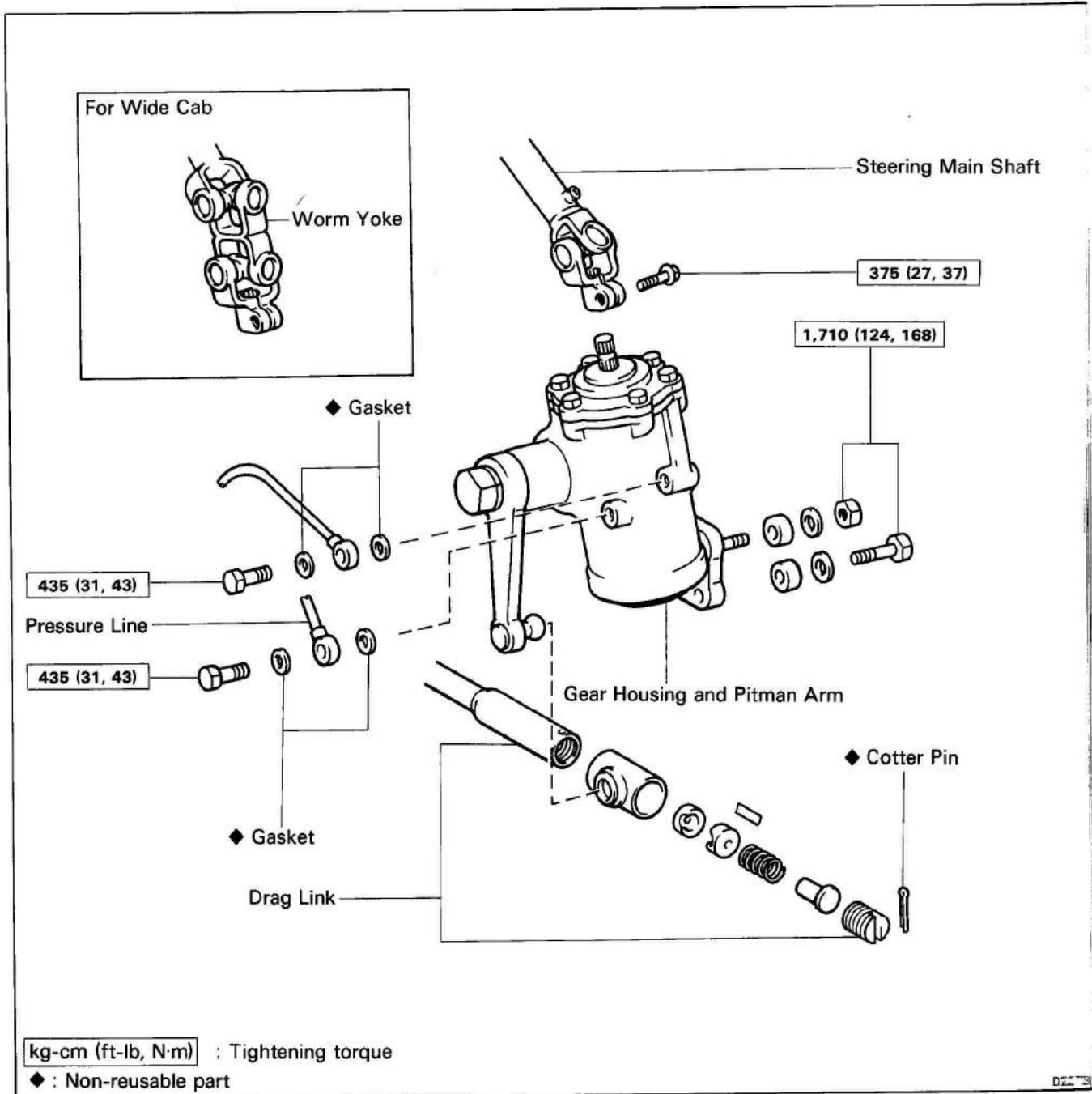

1. DISCONNECT RETURN LINE AND PRESSURE LINE
2. REMOVE WORM YOKE BOLT  
(See page SR-5)
3. REMOVE STEERING GEAR HOUSING  
(See page SR-17)

NOTE: Do not remove the pitman arm and nut.

COMPONENTS

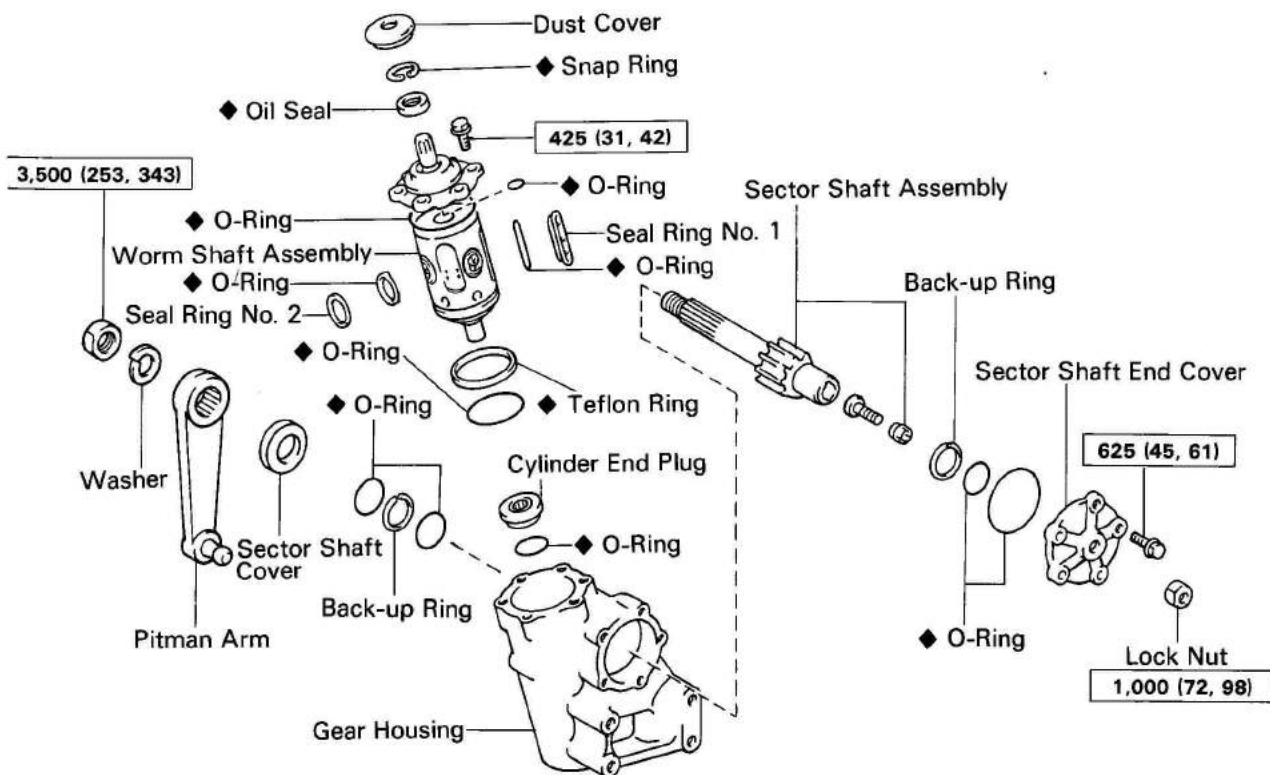

g-cm (ft-lb, N·m) : Tightening torque

◆ : Non-reusable part

D1289

cardiagn.com

DISASSEMBLY OF GEAR HOUSING

1. REMOVE PITMAN ARM

- (a) Clamp the gear housing in a vise.
- (b) Remove the pitman arm nut.
- (c) Using SST, remove the pitman arm.  
SST 09950-20015

2. REMOVE SECTOR SHAFT COVER

3. REMOVE SECTOR SHAFT END COVER

- (a) Remove the adjusting screw lock nut.
- (b) Remove the five end cover mounting bolts.
- (c) Turn the adjusting screw clockwise until the cover comes off.

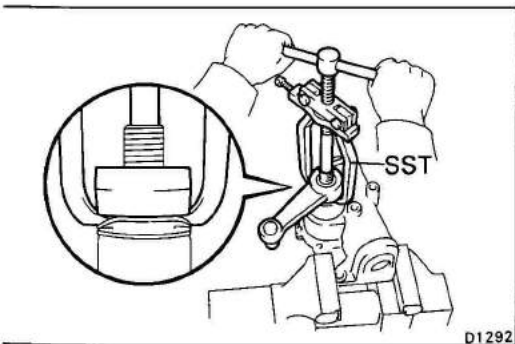

D1292

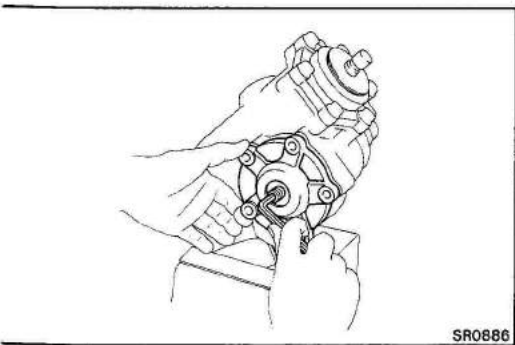

SR0886

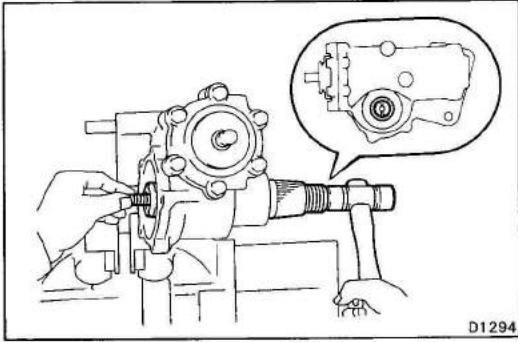

#### 4. TAP OUT SECTOR SHAFT

Using a plastic hammer, tap on the sector shaft end and pull out the shaft.

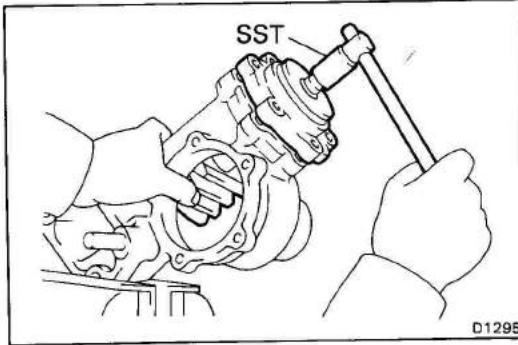

#### 5. REMOVE WORM SHAFT ASSEMBLY

- (a) Remove the six worm shaft cover bolts.
- (b) Using SST, turn the worm shaft clockwise until the shaft is locked. Then turn the worm shaft counter-clockwise until the end cover is separated from the housing by holding the power piston with your finger.

SST 09616-00010

**CAUTION:** Do not separate the end cover from the housing over 60 mm (2.36 in.).

- (c) Install the wooden block or equivalent between the end cover and housing.
- (d) Using SST, turn the worm shaft clockwise until half the power piston is pulled out.

SST 09616-00010

- (e) With holding the power piston, pull out the worm shaft assembly.

**CAUTION:** Do not allow the worm gear to spin off the shaft.

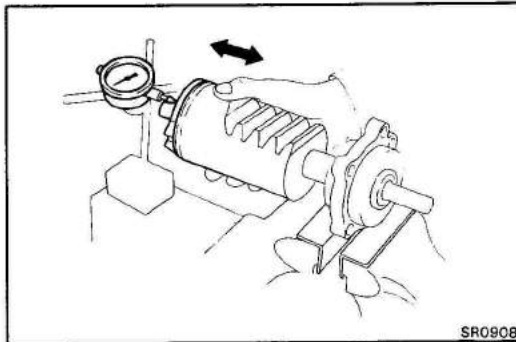

### INSPECTION OF GEAR HOUSING

#### 1. CHECK BALL CLEARANCE

- (a) Mount the worm shaft assembly in a vise.
- (b) Using a dial indicator, check the ball clearance by moving the power piston backward and forward.

**Maximum ball clearance: 0.05 mm (0.0020 in.)**

If clearance is excessive, replace the worm shaft assembly.

#### 2. CHECK SECTOR SHAFT ADJUSTING SCREW END PLAY

- (a) Clamp the sector shaft in a vise.
- (b) Using a dial indicator, check the end play.

**End play: Less than 0.15 mm (0.0059 in.)**

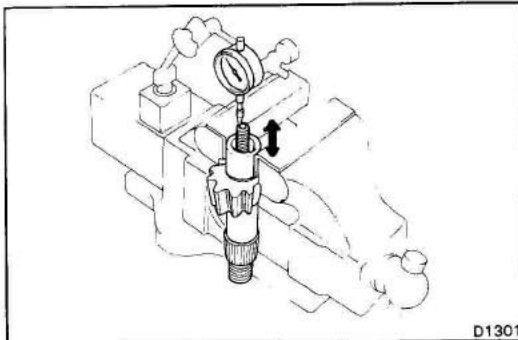

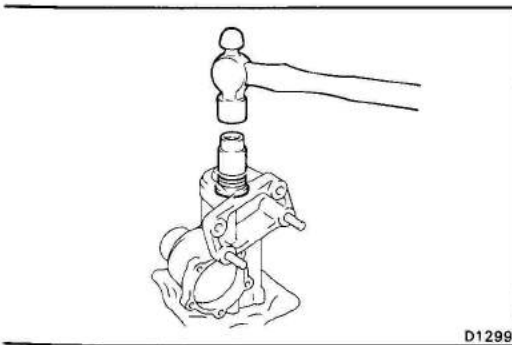
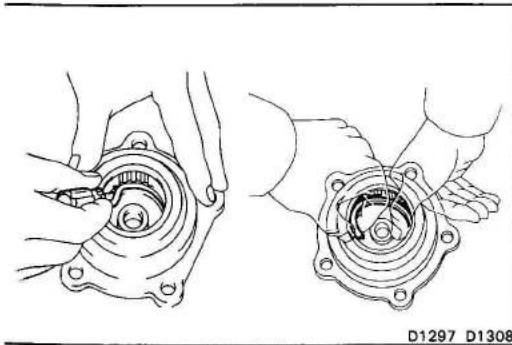
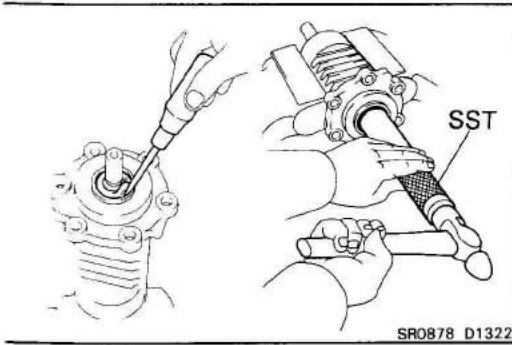
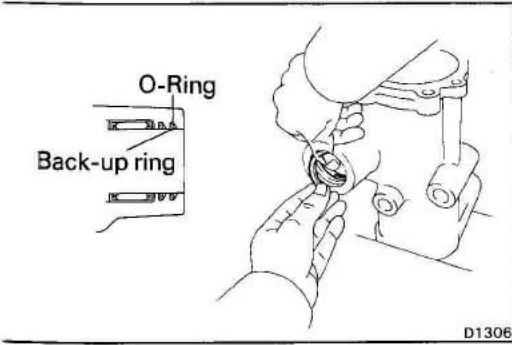
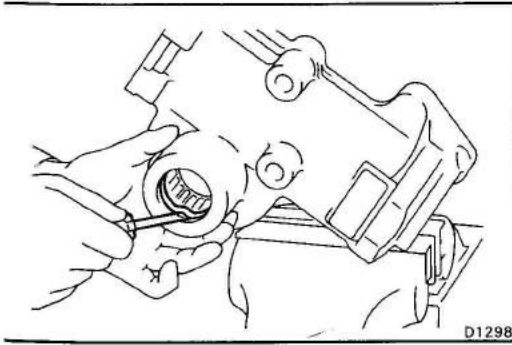

**3. INSPECT GEAR HOUSING**

- (a) Check the needle roller bearings for pitmarks or damage.
- (b) Check the back-up ring and O-rings for damage.

**4. REPLACE BACK-UP RING AND O-RINGS**

- (a) Using a screwdriver, remove the back-up ring and O-rings.

- (b) Install the new O-rings.

- (c) Form the new back-up ring into a heart shape and install with your finger.

NOTE: Apply power steering fluid to the O-rings and back-up ring before install.

**5. INSPECT WORM SHAFT COVER**

**6. IF NECESSARY, REPLACE OIL SEAL**

- (a) Remove the snap ring.
- (b) Using a screwdriver, remove the oil seal.
- (c) Using SST, install the oil seal.

SST 09612-22011

- (d) Install the snap ring.

**7. INSPECT END COVER**

- (a) Check the needle roller bearings for pitmarks or damage.
- (b) Check the back-up ring and O-rings for damage.

**8. REPLACE BACK-UP RING AND O-RINGS**

- (a) Using a screwdriver remove the back-up ring and O-rings.
- (b) Install the new O-rings.
- (c) Form the back-up ring into a heart shape and install it with your finger.

**9. INSPECT CYLINDER END PLUG**

- (a) Check the needle roller bearings for pitmarks or damage.
- (b) Check the oil leakage of housing.

**10. IF NECESSARY, REPLACE CYLINDER END PLUG**

- (a) Using a 32 mm socket wrench, tap out the cylinder end plug.

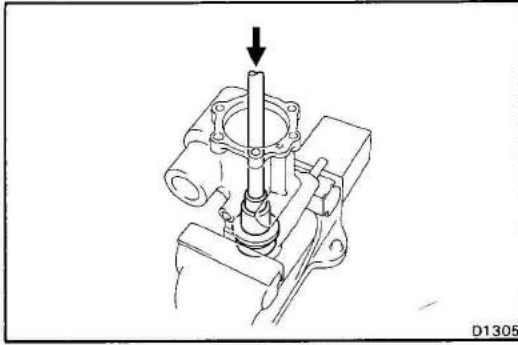

- (b) Install the new O-ring to the cylinder end plug.
- (c) Tap in the cylinder end plug.

**CAUTION:** Be careful not to force in the O-ring.

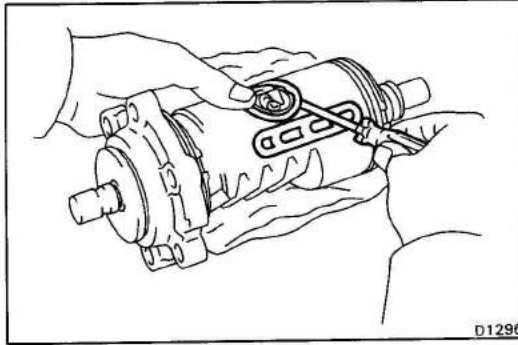

## ASSEMBLY OF GEAR HOUSING

(See page SR-47)

### 1. REPLACE SEAL RING NO. 1 AND NO. 2

- (a) Using a screwdriver, remove the seal ring No. 1, No. 2 and O-rings.
- (b) Install the O-rings, seal ring No. 1 and No. 2.

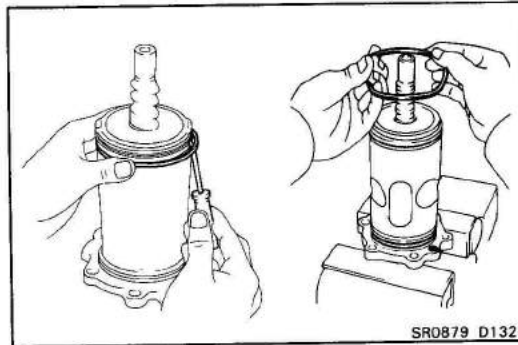

### 2. REPLACE TEFLON RING

- (a) Using a screwdriver, remove the teflon ring and O-ring.
- (b) Install the O-ring.
- (c) Stretch the teflon ring before installing it to the power piston.

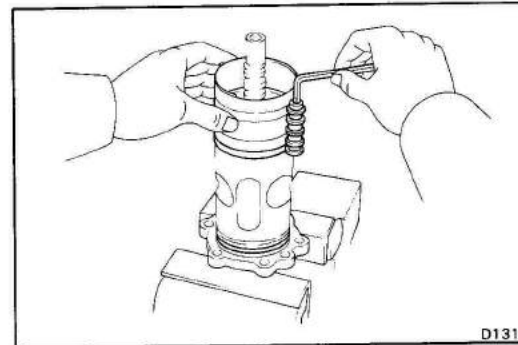

- (d) Using an engine piston ring compressor, compress the teflon ring for 5 – 7 minutes to break it in.

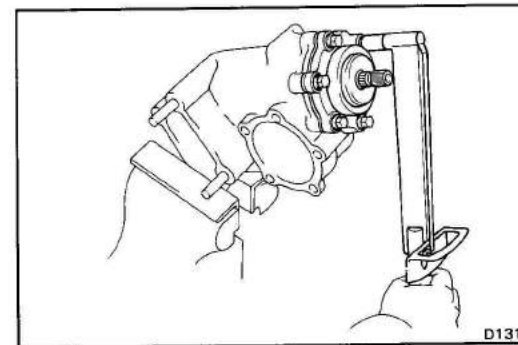

### 3. INSTALL WORM SHAFT ASSEMBLY

- (a) Install the new O-ring on the worm shaft cover.
- (b) Insert the worm shaft assembly into the housing.
- (c) Tighten the valve body mounting bolts in a diagonal pattern.

**Torque:** 425 kg-cm (31 ft-lb, 42 N·m)

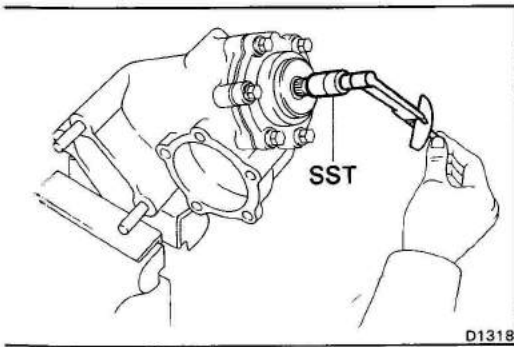

(d) Using SST, check the preload.

SST 09616-00010

**Preload (at starting): 7 – 14 kg-cm  
(6.1 – 12.2 in.-lb, 0.7 – 1.4 N-m)**

If the preload is not within limits or difference between clockwise and counterclockwise preload is over 4 kg-cm (3.5 in.-lb, 0.4 N-m), replace the worm shaft assembly.

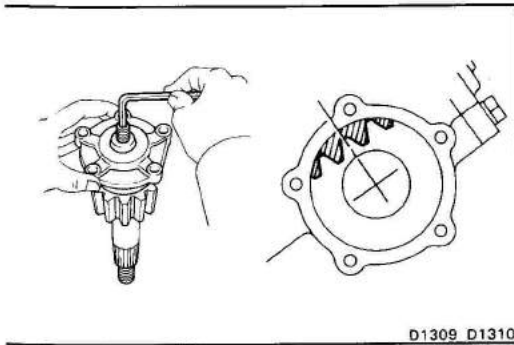

#### 4. INSTALL SECTOR SHAFT AND END COVER

(a) Install a new O-ring on the end cover.

(b) Assemble the sector shaft to the end cover.

**NOTE:** Fully loosen the adjusting screw.

(c) Set the worm gear at the center of the gear housing.

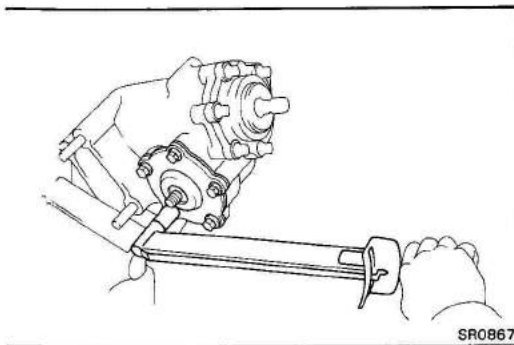

(d) Insert and push the sector shaft into the gear housing so that the center teeth mesh together.

(e) Tighten the end cover mounting bolts in a diagonal pattern.

**Torque: 625 kg-cm (45 ft.-lb, 61 N-m)**

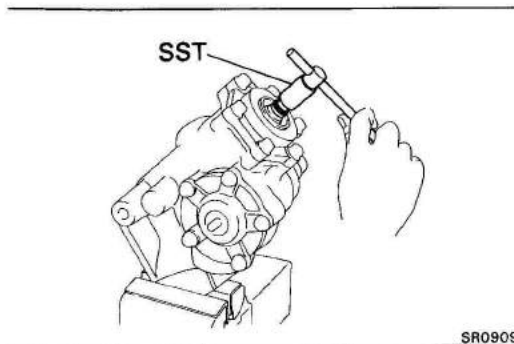

#### 5. DETERMINE CENTER POSITION OF GEAR BOX

Using SST, turn the worm shaft to full lock position in both directions and determine the exact center.

SST 09616-0010

#### 6. ADJUST TOTAL PRELOAD

Using SST, turn the adjusting screw while measuring the preload until it is correct.

SST 09616-00010

(a) Rotate the worm shaft one complete turn from neutral position and measure the preload.

**Preload (at starting): 7 – 14 kg-cm  
(6.1 – 12.2 in.-lb, 0.7 – 1.4 N-m)**

(b) Return the worm shaft to neutral position and again measure the preload. The preload at neutral position should be 1 – 3 kg-cm (0.9 – 2.6 in.-lb, 0.1 – 0.3 N-m) more than at the position listed in step (a).

**Total preload (at neutral position):**

**8 – 17 kg-cm (6.9 – 14.8 in.-lb, 0.8 – 1.7 N-m)**

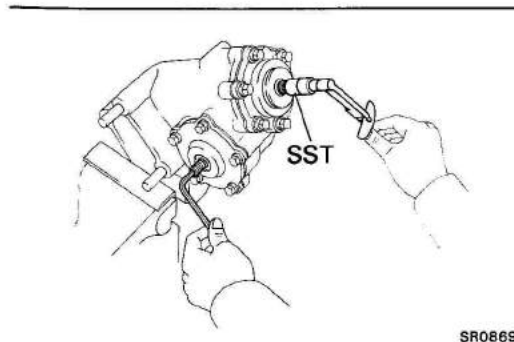

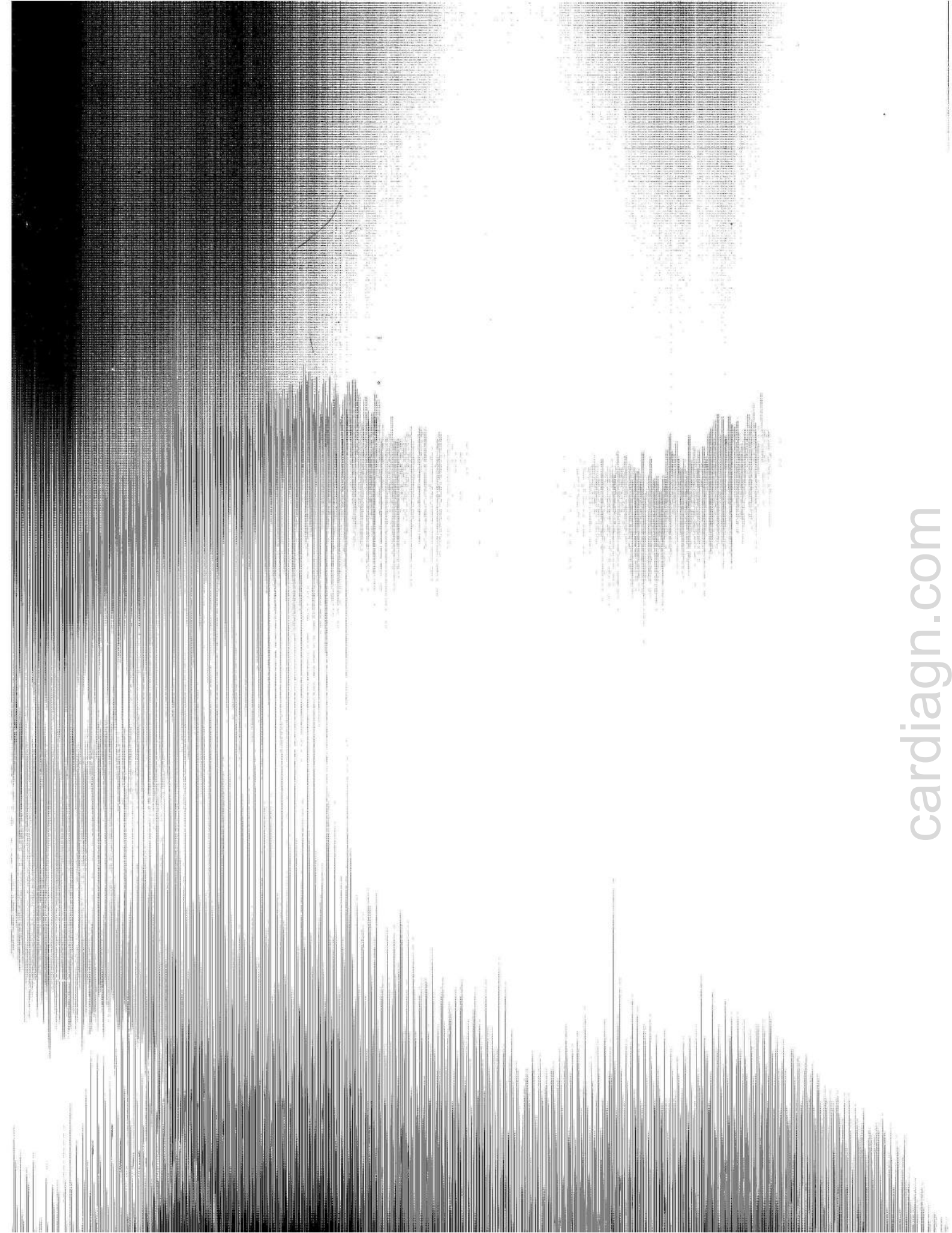

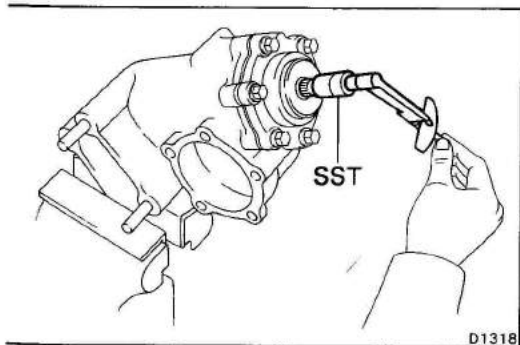

D1318

(d) Using SST, check the preload.

SST 09616-00010

**Preload (at starting): 7 – 14 kg-cm**  
(6.1 – 12.2 in.-lb, 0.7 – 1.4 N·m)

If the preload is not within limits or difference between clockwise and counterclockwise preload is over 4 kg-cm (3.5 in.-lb, 0.4 N·m), replace the worm shaft assembly.

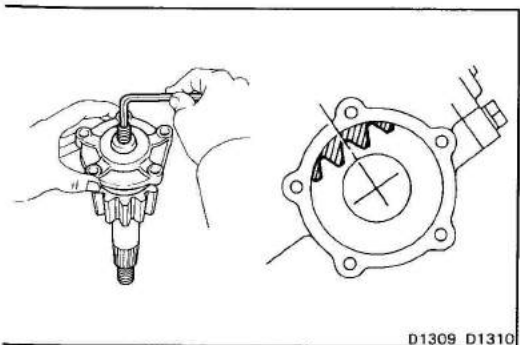

D1309 D1310

#### 4. INSTALL SECTOR SHAFT AND END COVER

(a) Install a new O-ring on the end cover.

(b) Assemble the sector shaft to the end cover.

**NOTE:** Fully loosen the adjusting screw.

(c) Set the worm gear at the center of the gear housing.

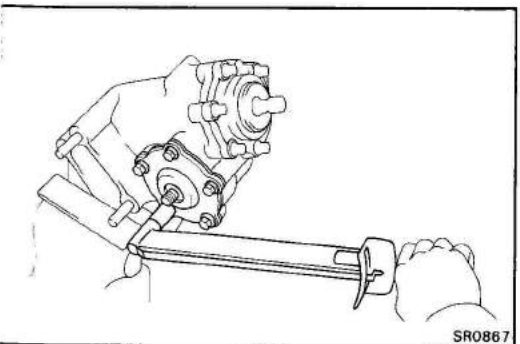

SR0867

(d) Insert and push the sector shaft into the gear housing so that the center teeth mesh together.

(e) Tighten the end cover mounting bolts in a diagonal pattern.

**Torque: 625 kg-cm (45 ft-lb, 61 N·m)**

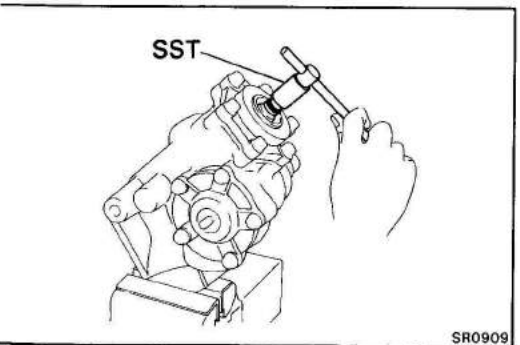

SR0909

#### 5. DETERMINE CENTER POSITION OF GEAR BOX

Using SST, turn the worm shaft to full lock position in both directions and determine the exact center.

SST 09616-00010

#### 6. ADJUST TOTAL PRELOAD

Using SST, turn the adjusting screw while measuring the preload until it is correct.

SST 09616-00010

(a) Rotate the worm shaft one complete turn from neutral position and measure the preload.

**Preload (at starting): 7 – 14 kg-cm**  
(6.1 – 12.2 in.-lb, 0.7 – 1.4 N·m)

(b) Return the worm shaft to neutral position and again measure the preload. The preload at neutral position should be 1 – 3 kg-cm (0.9 – 2.6 in.-lb, 0.1 – 0.3 N·m) more than at the position listed in step (a).

**Total preload (at neutral position):**

**8 – 17 kg-cm (6.9 – 14.8 in.-lb, 0.8 – 1.7 N·m)**

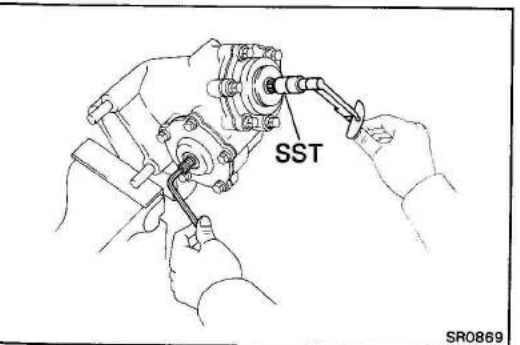

SR0869

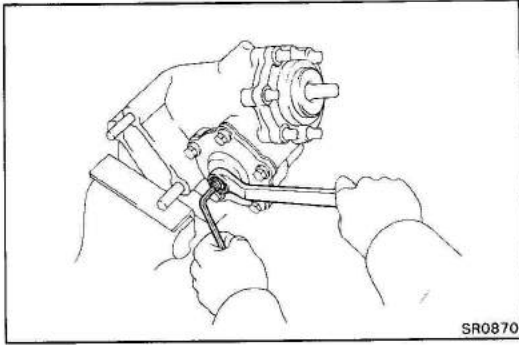

**7. INSTALL A NEW LOCK NUT AND TIGHTEN LOCK NUT**

Tighten the lock nut while holding the adjusting screw

**Torque: 1,000 kg-cm (72 ft-lb, 98 N·m)**

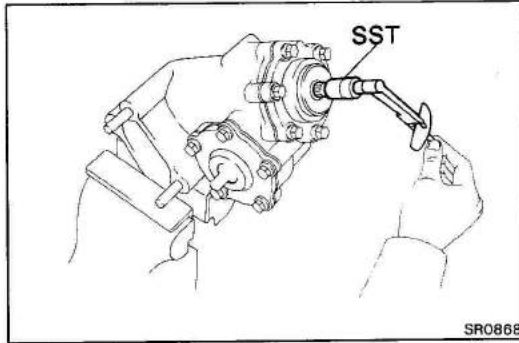

**8. RECHECK TOTAL PRELOAD**

Using SST, recheck the total preload.

SST 09616-00010

**Total preload (at neutral position):**

**8 – 17 kg-cm (6.9 – 14.8 in.-lb, 0.8 – 1.7 N·m)**

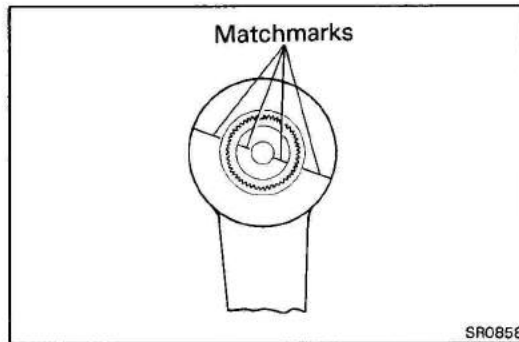

**9. INSTALL PITMAN ARM**

(a) Align the matchmarks on the sector shaft and pitman arm and install the arm.

(b) Tighten the pitman arm nut.

**Torque: 3,500 kg-cm (253 ft-lb, 343 N·m)**

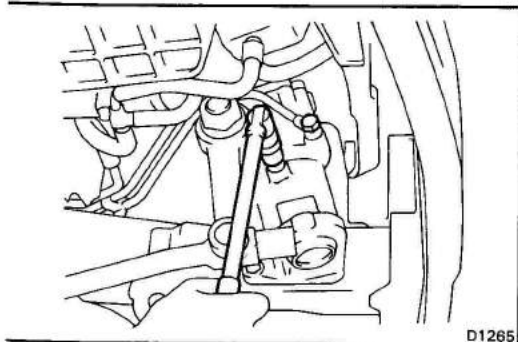

## INSTALLATION OF GEAR HOUSING

(See page SR-46)

1. **INSTALL GEAR HOUSING**  
(See page SR-27)

2. **CONNECT PRESSURE AND RETURN LINES**

Install the union bolts over the gaskets and torque the union bolts.

**Torque: 435 kg-cm (31 ft-lb, 43 N·m)**

**NOTE:** Always use new gaskets.

3. **INSTALL WORM SHAFT TO WORM YOKE**  
(See page SR-15)

4. **FILL RESERVOIR WITH FLUID**

**Fluid: ATF DEXRON or DEXRON II**

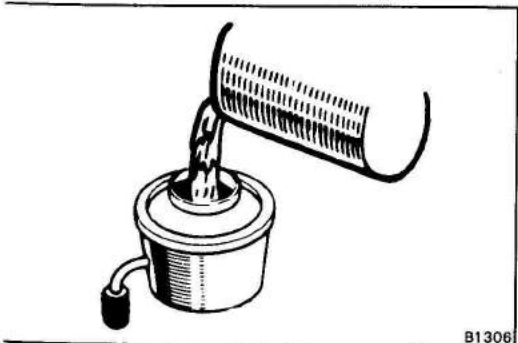

5. **BLEED POWER STEERING SYSTEM** (See page SR-31)

6. **PERFORM PRESSURE CHECK**  
(See page SR-31)

7. **CHECK FLUID LEAKAGE**

8. **CHECK FLUID LEVEL** (See page SR-29)



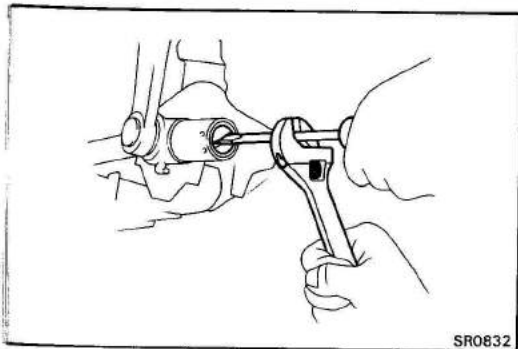

**2. DISCONNECT DRAG LINK FROM PITMAN ARM**  
Remove the cotter pin and drag link adjust plug from the pitman arm side.

**3. (Diesel Engine, RHD)**  
**IF NECESSARY, REMOVE VACUUM TANK**

**4. (w/PS)**  
**IF NECESSARY, REMOVE RIGHT SIDE FRONT STEP**

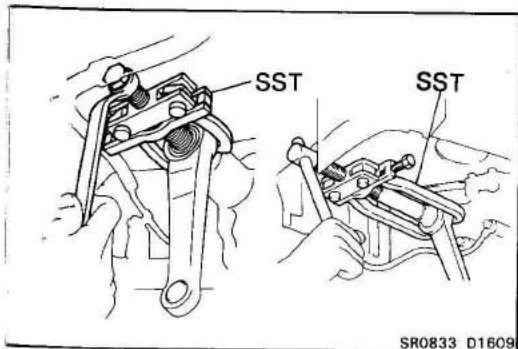

**5. DISCONNECT PITMAN ARM FROM SECTOR SHAFT**  
Using SST, disconnect the pitman arm from the sector shaft.

SST 09950-20015

**6. INSPECT ARM FOR DAMAGE OR CRACKS**  
Check for cracks with flaw detecting penetrant.

### INSTALLATION OF PITMAN ARM

(See page SR-54)

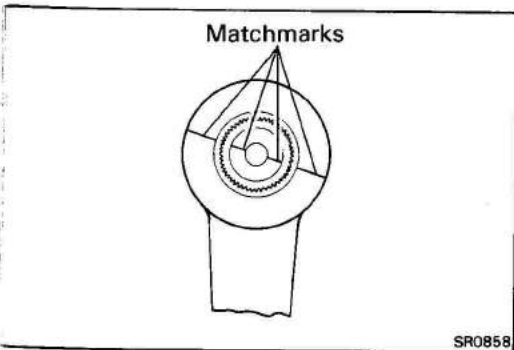

**1. CONNECT PITMAN ARM TO SECTOR SHAFT**

Align matchmarks on the pitman arm and the sector shaft, and install the nut.

**2. INSTALL DRAG LINK TO PITMAN ARM**

(a) Install the pitman arm side as shown in the figure.

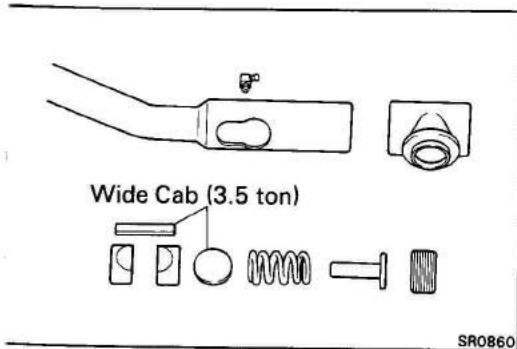

(b) Tighten the adjusting plug completely and then loosen it 1-1 1/3 turns.

(c) Install the new cotter pin.

(d) Apply chassis grease to the nipple.

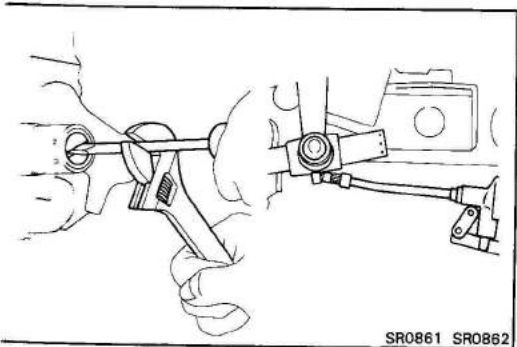

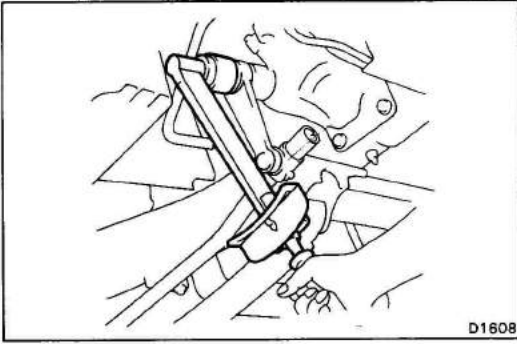

### 3. TIGHTEN PITMAN ARM NUT

Torque the pitman arm nut.

Torque:

**Manual** 2,500 kg-cm (181 ft-lb, 245 N·m)

**Power** 3,500 kg-cm (253 ft-lb, 343 N·m)

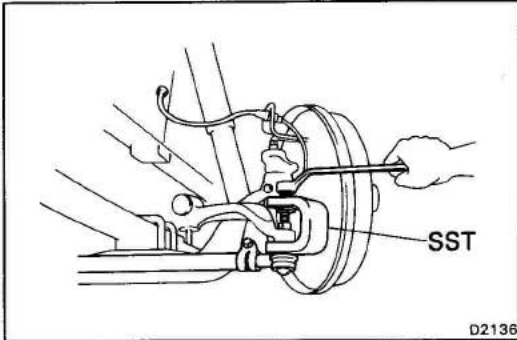

## Tie Rod

### REMOVAL AND INSPECTION OF TIE ROD

(See page SR-54)

#### 1. REMOVE WHEEL

#### 2. DISCONNECT TIE ROD FROM RELAY ROD AND KNUCKLE ARM

Using SST, disconnect the tie rod.

SST 09611-36020

#### 3. INSPECT BALL JOINT FOR ROTATION CONDITION

(a) Clamp the ball joint in vise.

(b) As shown in the figure, flip the ball joint stud back and forth 5 times before installing the nut.

(c) Using a torque gauge, turn the nut continuously one turn each 2-4 seconds and take the torque reading on the fifth turn.

Torque (turning):

**Regular Cab** 16 – 75 kg-cm  
(14 – 65 in.-lb, 1.6 – 7.4 N·m)

**Wide Cab** 40 – 80 kg-cm  
(35 – 69 in.-lb, 3.9 – 7.8 N·m)

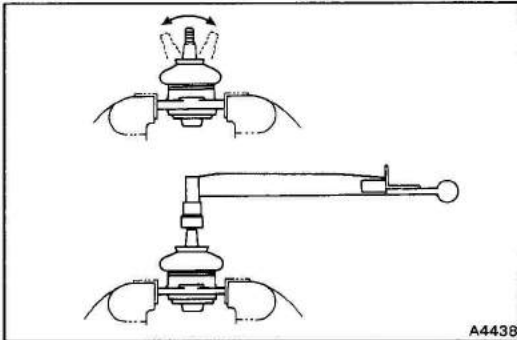

#### 4. INSPECT TIE ROD FOR WEAR, DAMAGE OR CRACKS

Check for wear or damage and check for cracks with flaw detecting penetrant.

### INSTALLATION OF TIE ROD (See page SR-54)

#### 1. ASSEMBLE TIE ROD

(a) Loosen the tie rod end clamp bolts.

(b) Screw the tie rod ends into the adjusting tube. The remaining length of the threads on both tie rod ends should be equal.

Tie rod length:

**Regular Cab** 1,158 ± 2 mm  
(45.59 ± 0.08 in.)

**Wide Cab (Ex. WU series)** 1,384 ± 2 mm  
(54.49 ± 0.08 in.)

**Wide Cab (WU series)** 1,420 mm (55.91 in.)

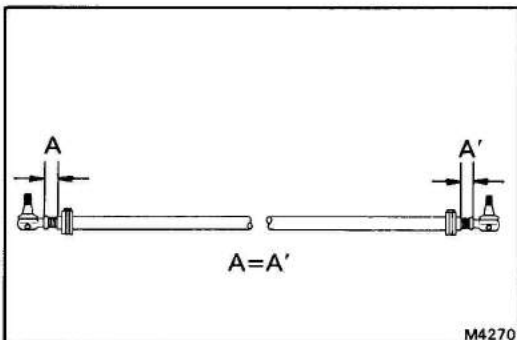

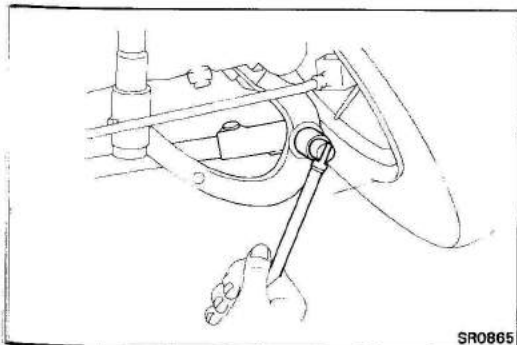

**2. CONNECT TIE ROD END**

(a) Torque the mounting nuts.

Torque:

<b>Regular Cab</b>	<b>1,550 kg-cm</b> <b>(112 ft-lb, 152 N·m)</b>
<b>Wide Cab (BU 85 only)</b>	<b>950 kg-cm</b> <b>(69 ft-lb, 93 N·m)</b>
<b>Wide Cab (Ex. BU 85)</b>	<b>2,000 kg-cm</b> <b>(145 ft-lb, 196 N·m)</b>

(b) Install the new cotter pin.

(c) Provisionally torque the tie rod end clamp bolts.

**3. INSTALL WHEEL**

**4. ADJUST TOE-IN (See page FA-3)**

**5. TORQUE TIE ROD END CLAMP BOLTS**

Torque:

<b>Regular Cab and BU 85</b>	<b>375 kg-cm</b> <b>(27 ft-lb, 37 N·m)</b>
<b>Wide Cab (Ex BU 85)</b>	<b>760 kg-cm</b> <b>(55 ft-lb, 75 N·m)</b>

**Drag Link**

**REMOVAL AND INSPECTION OF DRAG LINK**

(See page SR-54)

**1. DISCONNECT DRAG LINK FROM PITMAN ARM AND KNUCKLE ARM**

(a) Remove the two cotter pins and plugs on both sides with a screwdriver.

(b) Remove the drag link.

**2. INSPECT PARTS FOR WEAR OR DAMAGE**

**INSTALLATION OF DRAG LINK**

(See page SR-54)

**1. CONNECT DRAG LINK TO PITMAN ARM**

(a) Install the pitman arm side as shown in the figure.

(b) Tighten the plug completely and then loosen it 1-1/3 turns.

**2. CONNECT DRAG LINK TO KNUCKLE ARM**

(a) Install the knuckle arm side as shown in the figure.

(b) Tighten the plug completely and then loosen it 1-1/3 turns.

**3. APPLY CHASSIS GREASE TO BOTH NIPPLES**

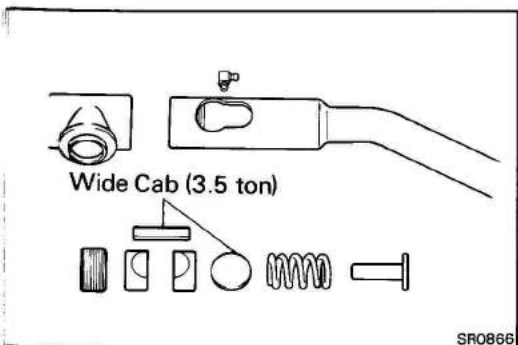
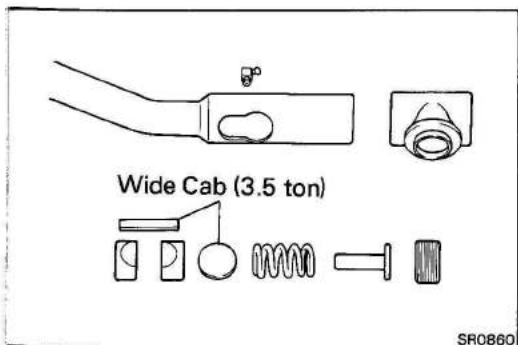
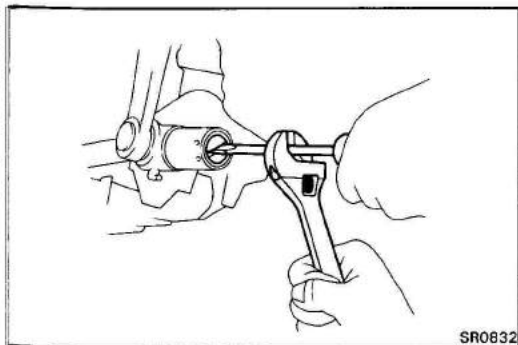

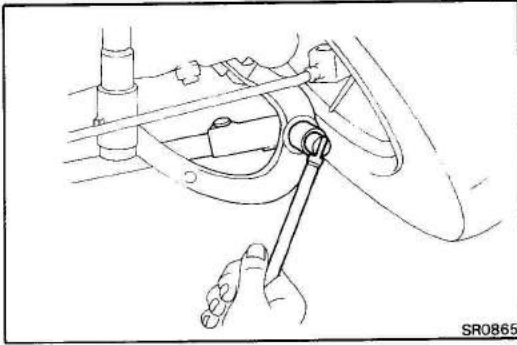

## Knuckle Arm

### REMOVAL AND INSPECTION OF KNUCKLE ARM

(See page SR-54)

1. **DISCONNECT TIE ROD END FROM KNUCKLE ARM**  
(See page SR-56)
2. **DISCONNECT DRAG LINK FROM KNUCKLE ARM**  
(See page SR-57)
3. **REMOVE KNUCKLE ARM**
  - (a) Using a hammer and chisel, loosen the staked part of the knuckle arm set nut. (Ex. BU90-95, WU series)
  - (b) Remove the cotter pin and mounting nut. (BU90-95, WU series)
  - (c) Using a hammer, remove the knuckle arm from the steering knuckle.
  - (d) Remove the woodruff key from the knuckle arm. (Ex. BU90-95, WU series)
4. **INSPECT KNUCKLE ARM FOR DAMAGE OR CRACKS**  
Check for cracks with flaw detecting penetrant.

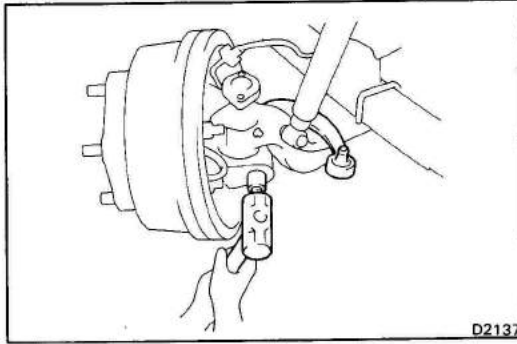

### INSTALLATION OF KNUCKLE ARM

(See page SR-54)

1. **INSTALL KNUCKLE ARM**
  - (a) Install the woodruff key to the knuckle arm. (Ex. BU90-95, WU series)
  - (b) Install the knuckle arm to the steering knuckle and torque the nut.

#### Torque:

BU90-95, WU series	7,000 kg-cm (506 ft-lb, 686 N·m)
Ex. BU90-95 WU series	4,000 kg-cm (289 ft-lb, 392 N·m)

NOTE: Use the new set nut except BU90-95, WU series.

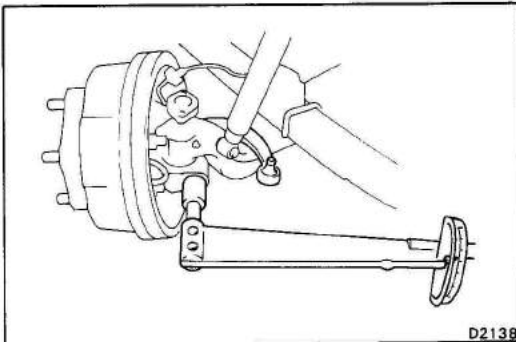

- (c) Using a hammer and punch, stake the set nut.  
(Ex. BU90-95, WU series)
- (d) Install the new cotter pin. (BU90-95, WU series)

**2. CONNECT DRAG LINK TO KNUCKLE ARM**  
(See page SR-57)

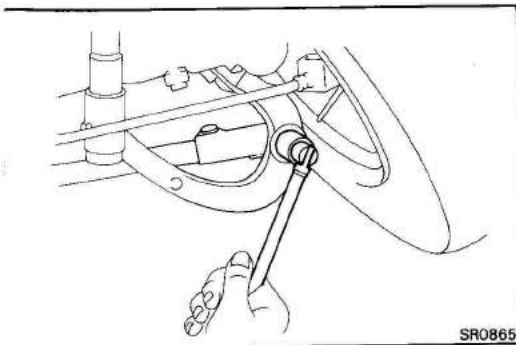

**3. CONNECT TIE ROD END TO KNUCKLE ARM**  
(See page SR-57)