

- * 1 : 1TR-FE, 2TR-FE, 1GR-FE
- * 2 : 1KD-FTV, 2KD-FTV, 5L-E
- * 3 : 1KD-FTV A/T, 2KD-FTV A/T
- * 4 : 1GR-FE A/T
- * 5 : w/ Short Connector (Theft Warning ECU)
- * 6 : w/o Short Connector (Theft Warning ECU)
- * 8 : 1TR-FE, 2TR-FE
- * 9 : 1KD-FTV, 2KD-FTV Except Cold Area Spec., 5L-E
- * 10 : 2KD-FTV Cold Area Spec.
- * 11 : 1KD-FTV, 2KD-FTV
- * 12 : 5L-E
- * 13 : Except 5L-E
- * 18 : 2TR-FE A/T
- * 20 : Before Aug. 2009 Production
- * 21 : From Aug. 2009 Production
- * 22 : w/ Theft Deterrent Except South Africa
- * 23 : South Africa 1GR-FE
- * 24 : Australia Before Aug. 2009 Production 1GR-FE
- * 25 : Australia From Aug. 2009 Production 1GR-FE
- * 26 : Before Jun. 2011 Production
- * 27 : From Jun. 2011 Production
- * 28 : 1KD-FTV A/T w/ DPF
- * 29 : 1GR-FE From Jun. 2011 Production
- * 32 : *8, 1GR-FE Before Jun. 2011 Production
- * 34 : Before Nov. 2011 Production
- * 35 : From Nov. 2011 Production
- * 36 : Before Aug. 2012 Production
- * 37 : From Aug. 2012 Production
- * 38 : Before Aug. 2013 Production
- * 39 : From Aug. 2013 Production

1 HILUX (Cont' d)

Charging

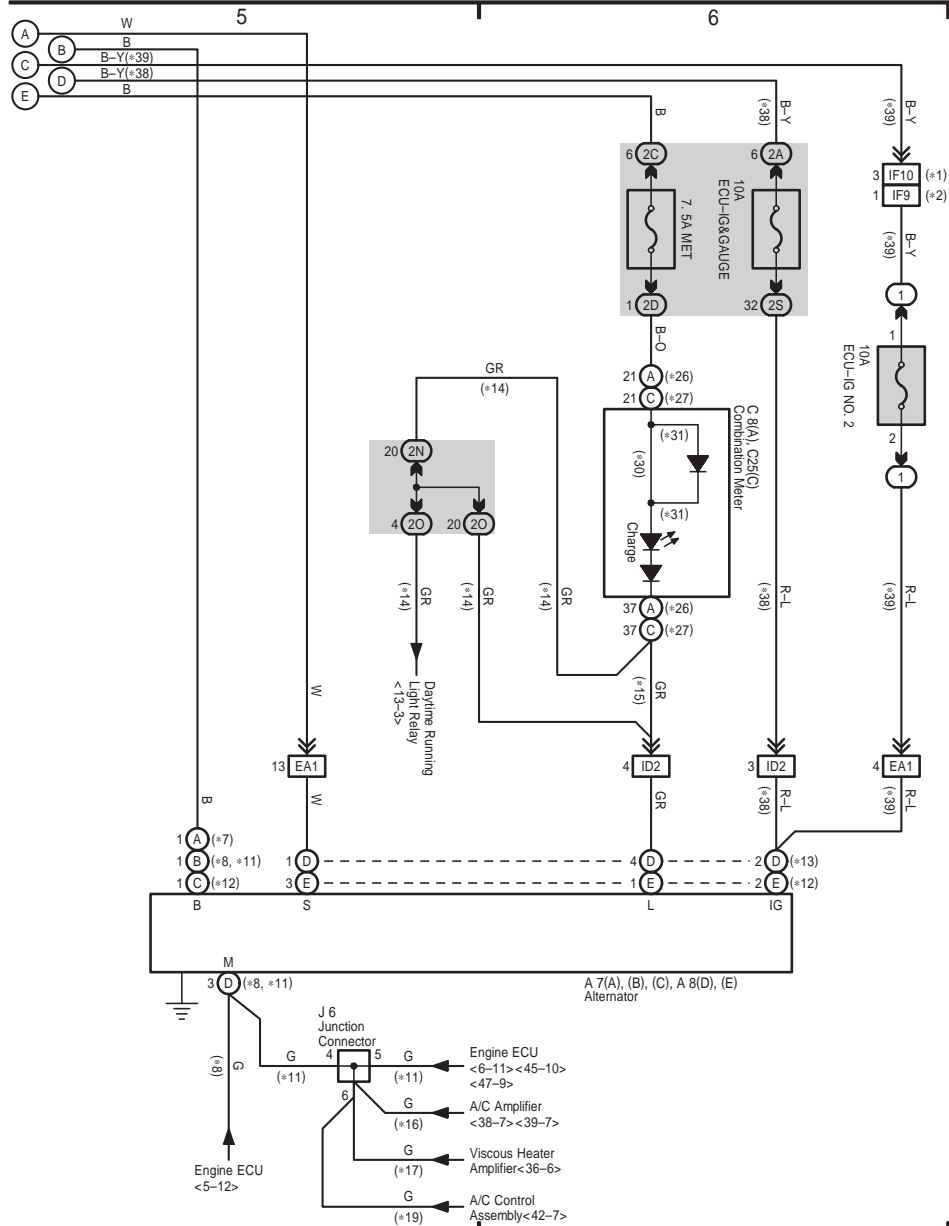

- * 1 : 1TR-FE, 2TR-FE, 1GR-FE
- * 2 : 1KD-FTV, 2KD-FTV, 5L-E
- * 7 : 1GR-FE
- * 8 : 1TR-FE, 2TR-FE
- * 11 : 1KD-FTV, 2KD-FTV
- * 12 : 5L-E
- * 13 : Except 5L-E
- * 14 : w/ Daytime Running Light
- * 15 : w/o Daytime Running Light
- * 16 : w/ PTC Heater w/ Manual A/C
- * 17 : w/ PTC Heater w/o Manual A/C
- * 19 : w/ Automatic A/C w/ PTC Heater
- * 26 : Before Jun. 2011 Production
- * 27 : From Jun. 2011 Production
- * 30 : *26, Middle East *27
- * 31 : *27 Except Middle East
- * 38 : Before Aug. 2013 Production
- * 39 : From Aug. 2013 Production

HILUX (EM1815E)

3 HILUX

Power Source

Ignition (1TR-FE, 2TR-FE)

- * 1 : Before Aug. 2008 Production
- * 3 : Before Jun. 2011 Production
- * 4 : From Jun. 2011 Production
- * 5 : Before Aug. 2013 Production
- * 6 : From Aug. 2013 Production
- * 7 : From Aug. 2008 Production until Aug. 2013 Production

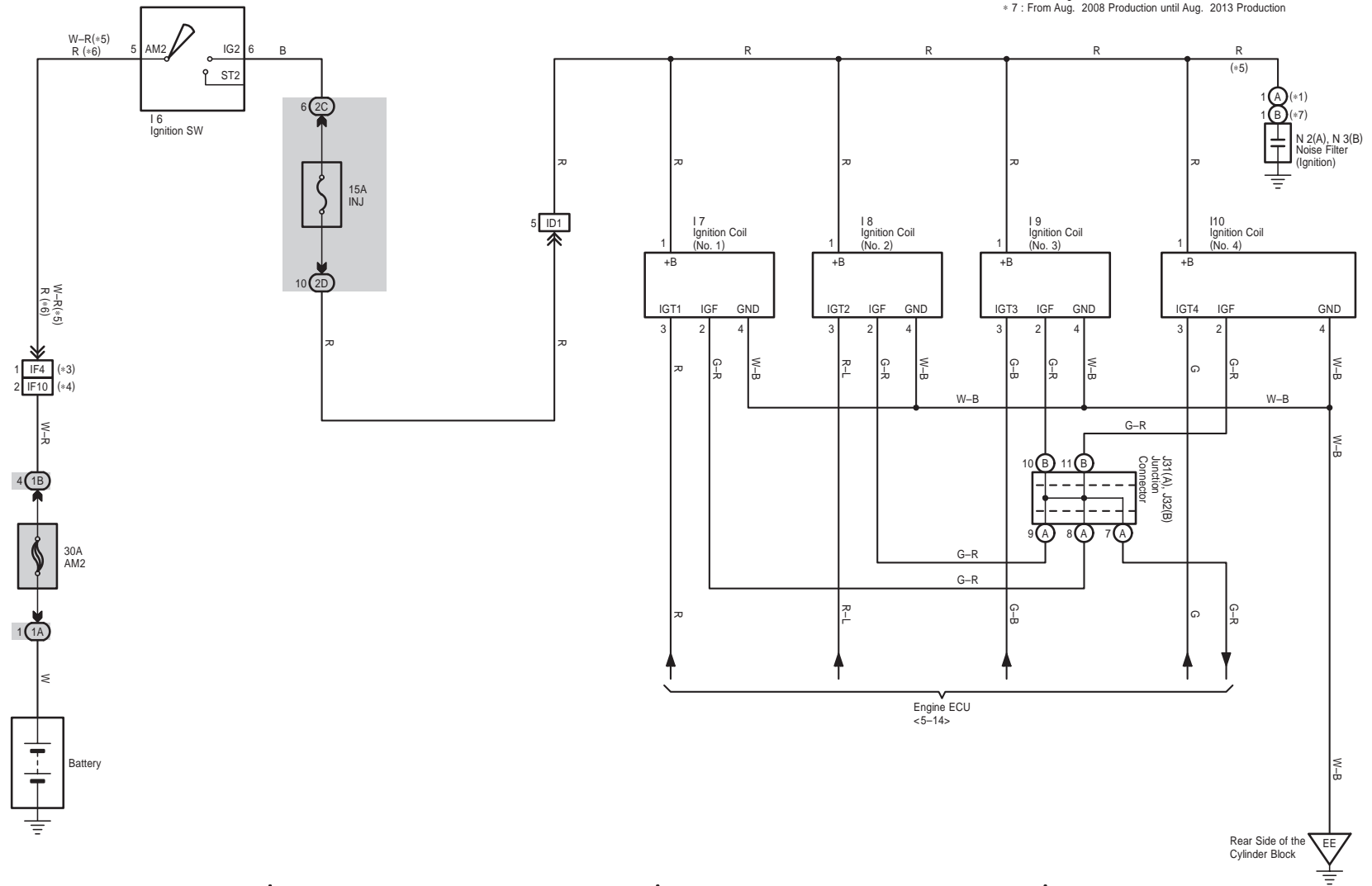

Power Source

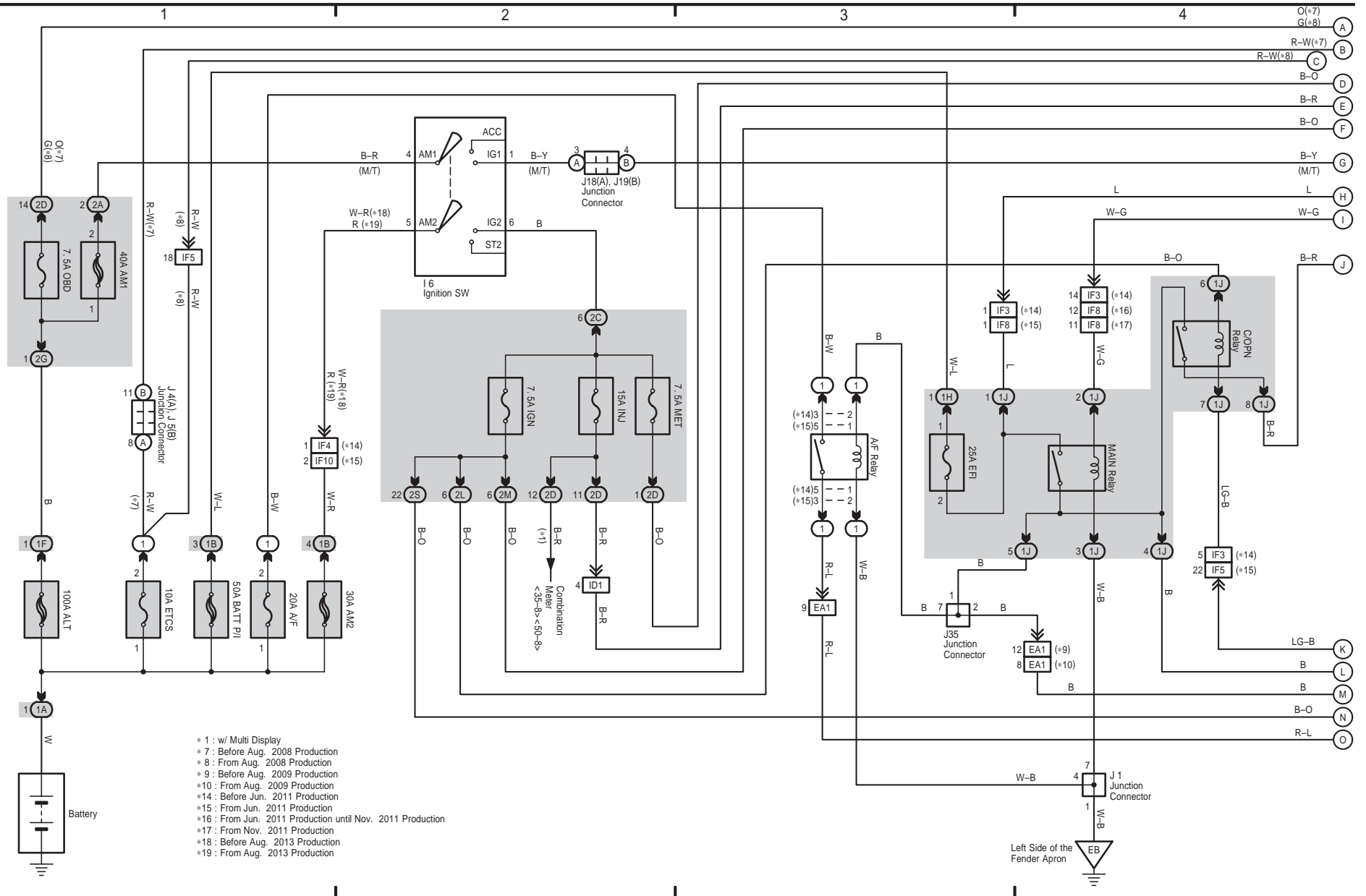

HILUX (EM1815E)

Engine Control (1GR-FE)

- * 1 : w/ Multi Display
- * 2 : w/ Cruise Control
- * 3 : w/ Rear Window Defogger

- * 7 : Before Aug. 2008 Production
- * 8 : From Aug. 2008 Production
- * 11 : Shielded

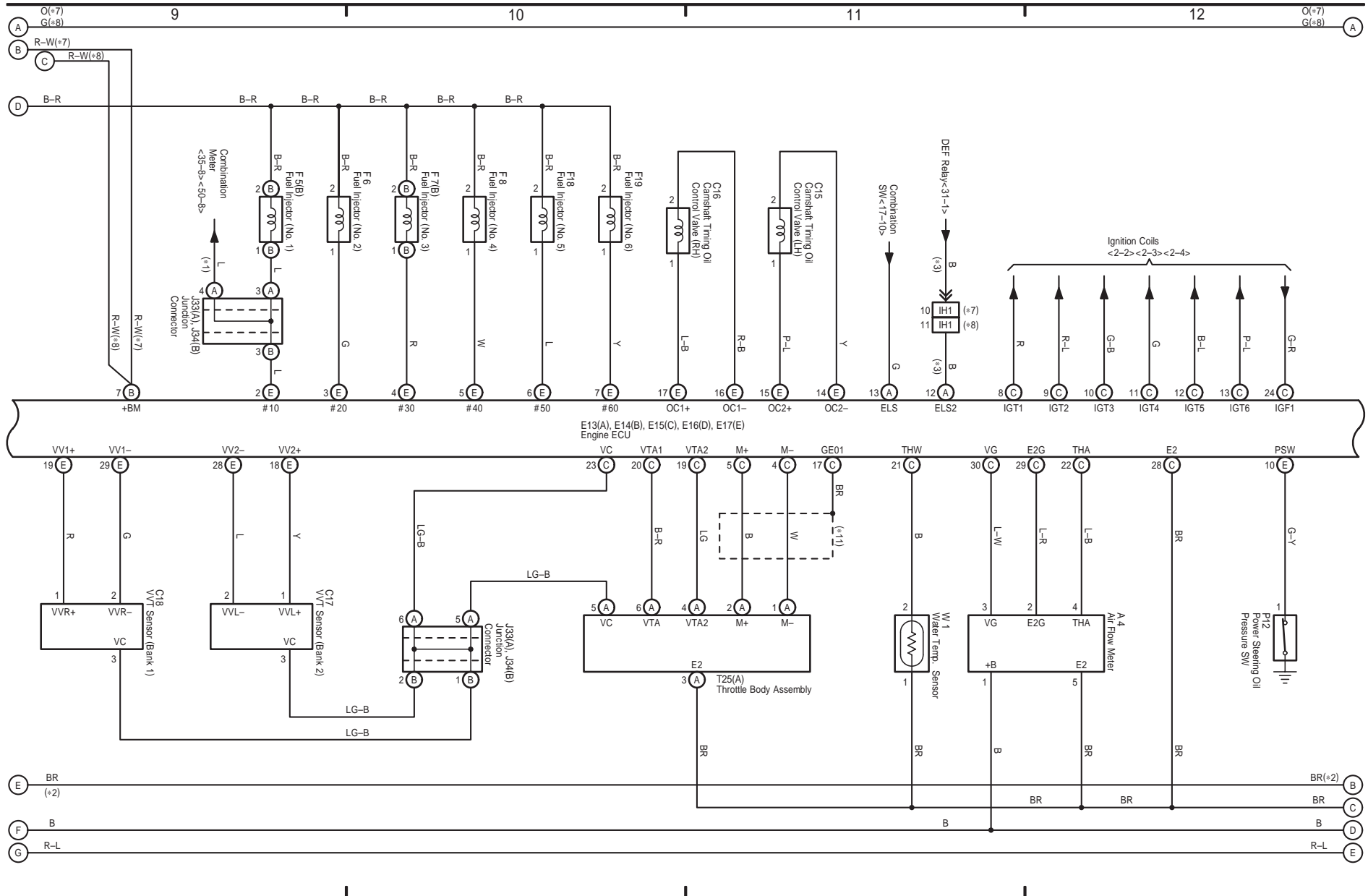

HILUX (EM1815E)

Engine Control (1GR-FE)

* 2 : w/ Cruise Control
 * 4 : w/ ADD
 * 5 : w/o ADD

* 7 : Before Aug. 2008 Production
 * 8 : From Aug. 2008 Production
 *11 : Shielded

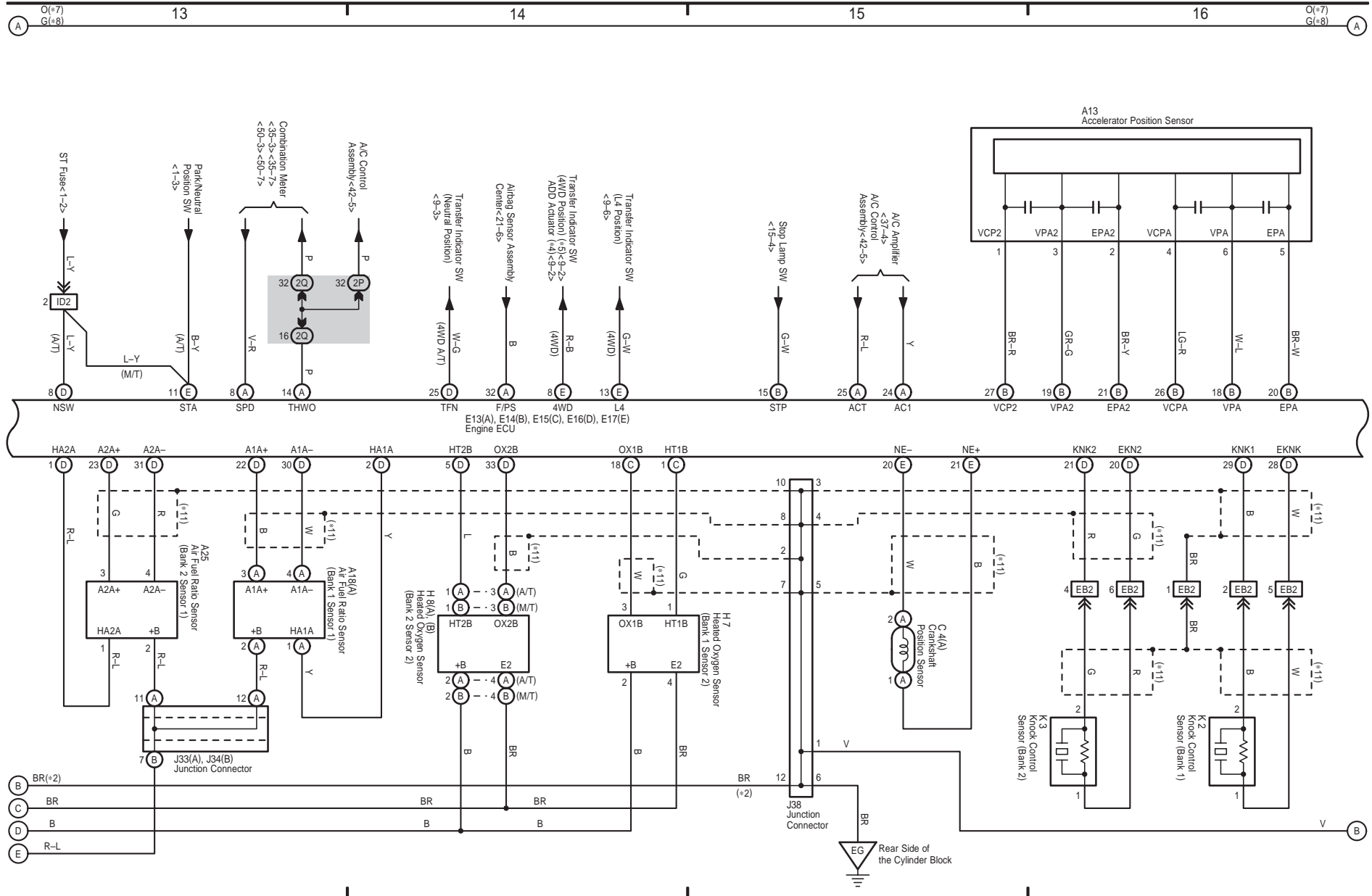

HILUX (EM1815E)

cardiagn.com

4 HILUX (Cont' d)

Engine Control (1GR-FE)

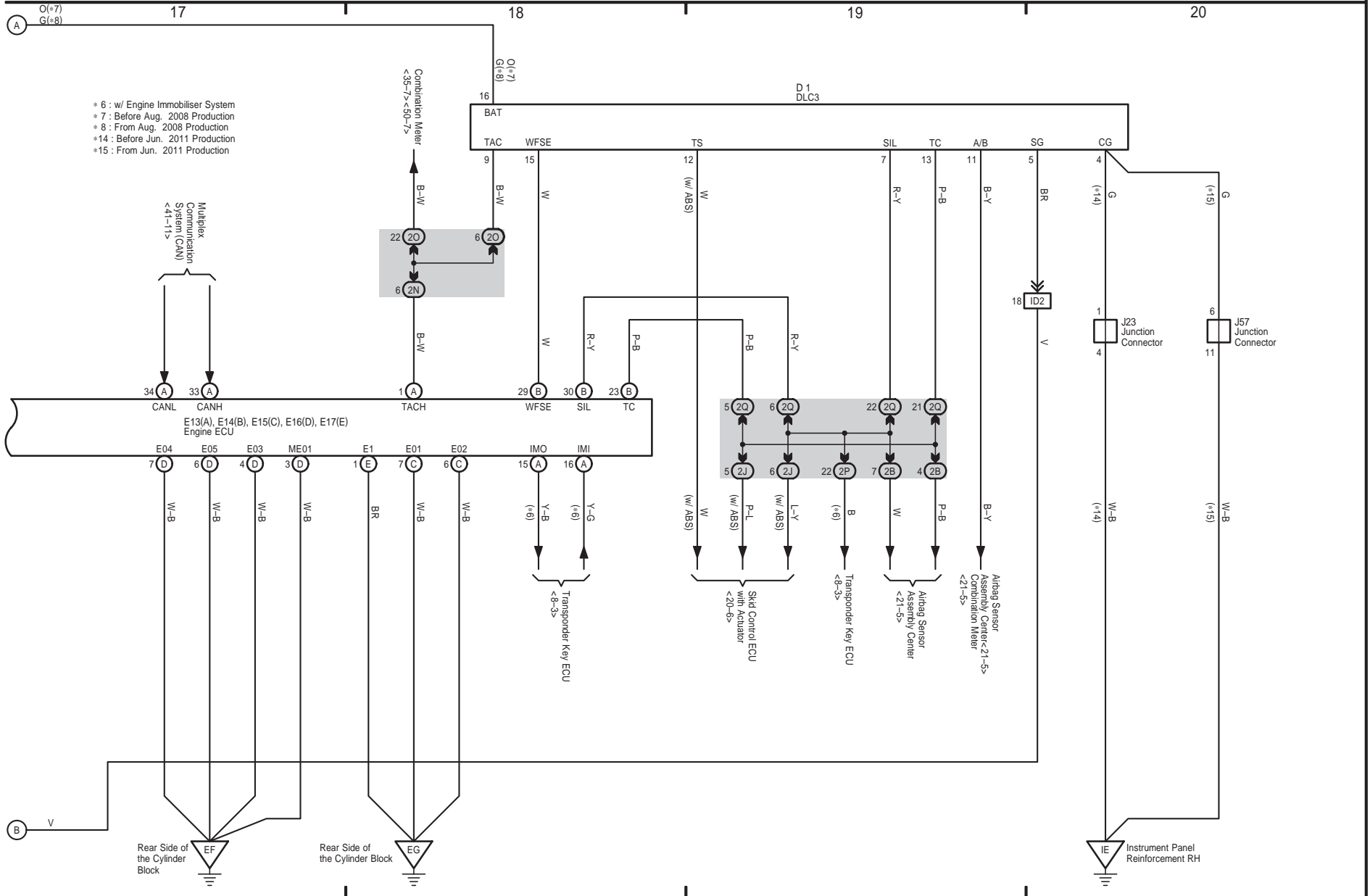

HILUX (EM1815E)

Engine Control (1TR-FE, 2TR-FE)

* 3 : w/ Multi Display
 * 6 : Unleaded Gasoline
 * 12 : Before Aug. 2008 Production
 * 13 : From Aug. 2008 Production

* 16 : w/ Air Injection Control Driver
 * 17 : w/o Air Injection Control Driver
 * 18 : Before Jun. 2011 Production
 * 19 : From Jun. 2011 Production

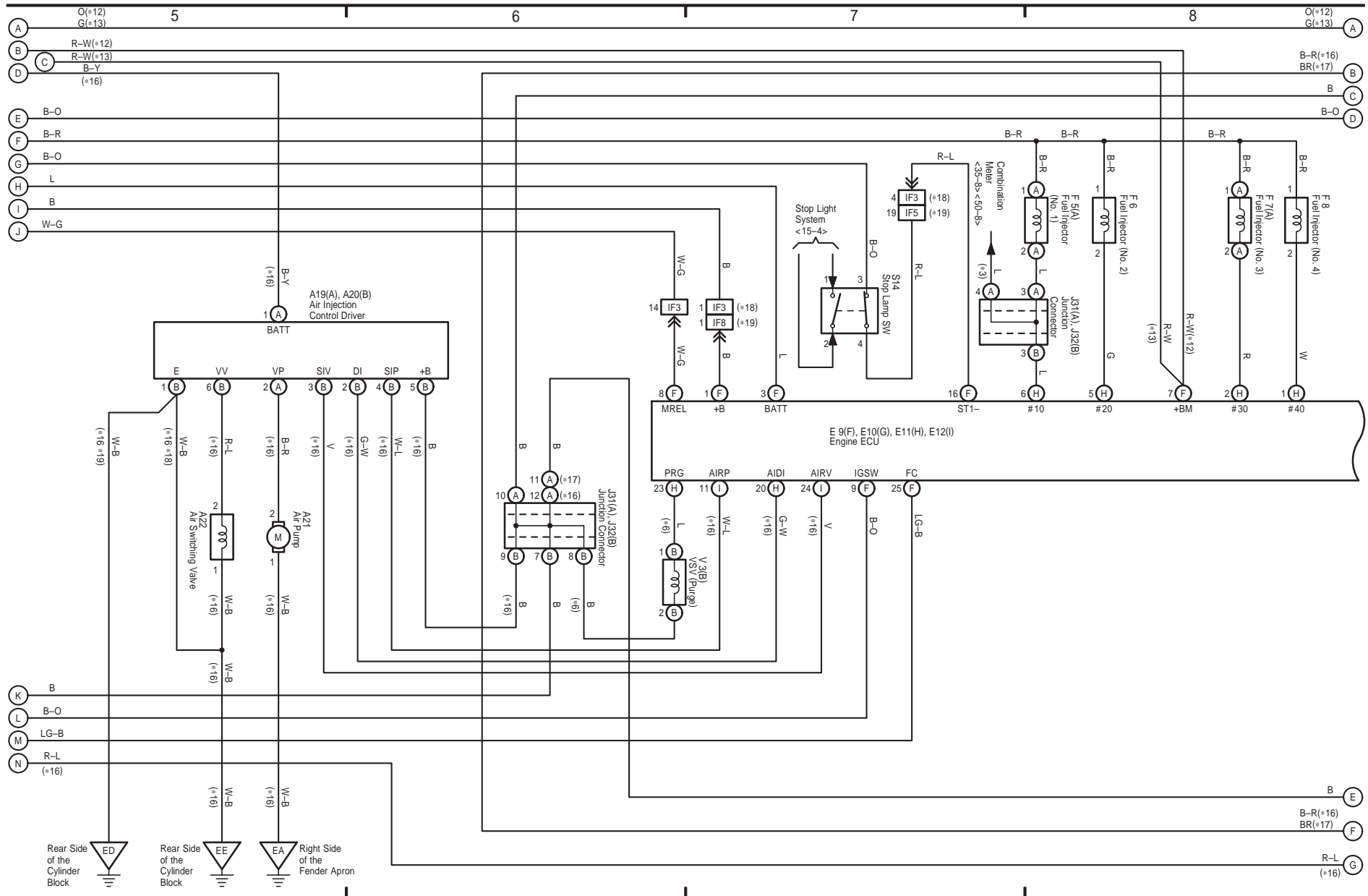

HILUX (EM1815E)

cardiagn.com

5 HILUX (Cont' d)

Engine Control (1TR-FE, 2TR-FE)

- *1 : Australia 2TR-FE
- *2 : Except Australia
- *6 : Unleaded Gasoline
- *9 : w/ Engine Immobiliser System
- *12 : Before Aug. 2008 Production

- *13 : From Aug. 2008 Production
- *16 : w/ Air Injection Control Driver
- *18 : Before Jun. 2011 Production
- *19 : From Jun. 2011 Production

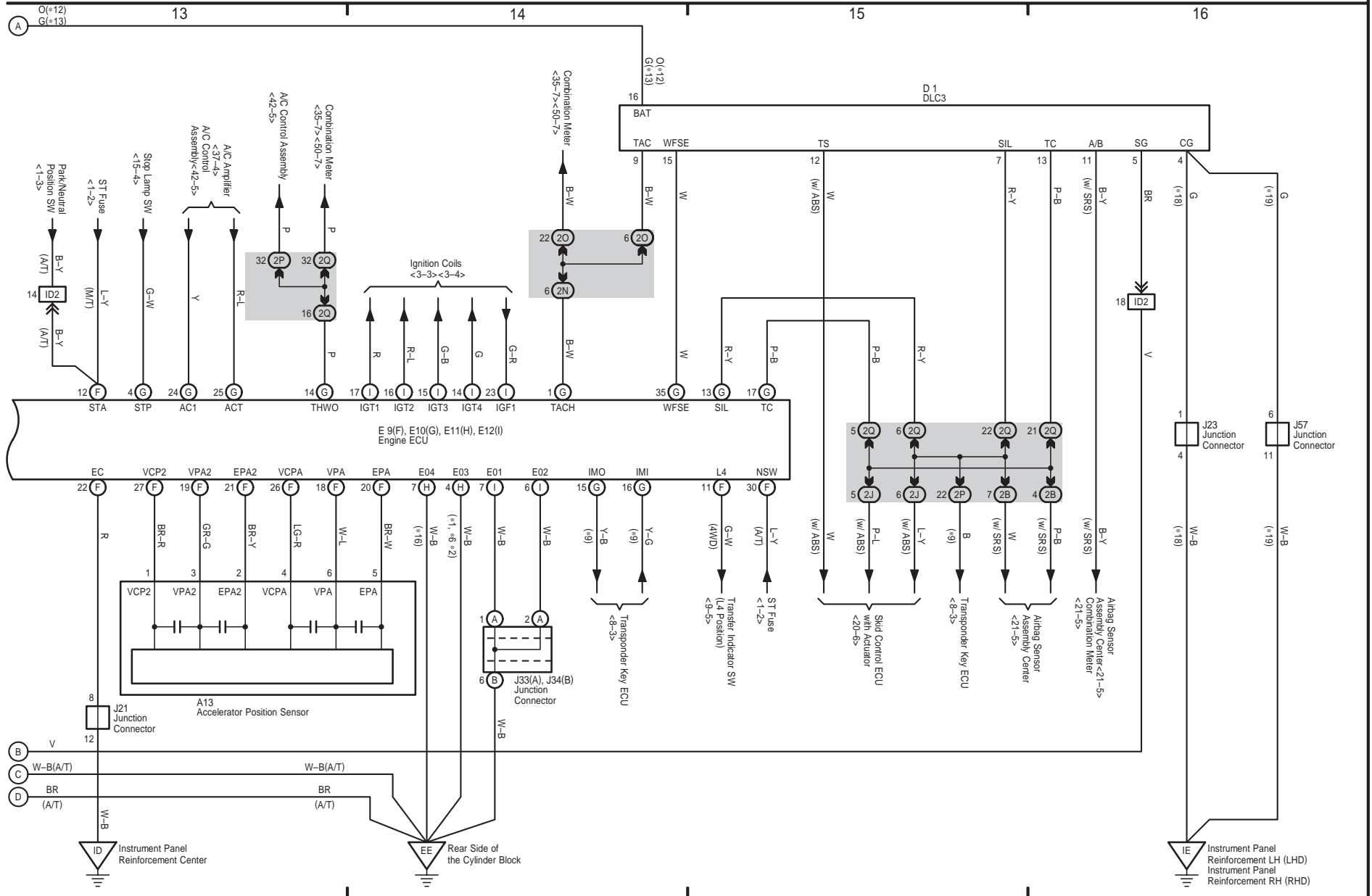

HILUX (EM1815E)

cardiagn.com

M

HILUX (EM1815E)

M OVERALL ELECTRICAL WIRING DIAGRAM

cardiagn.com

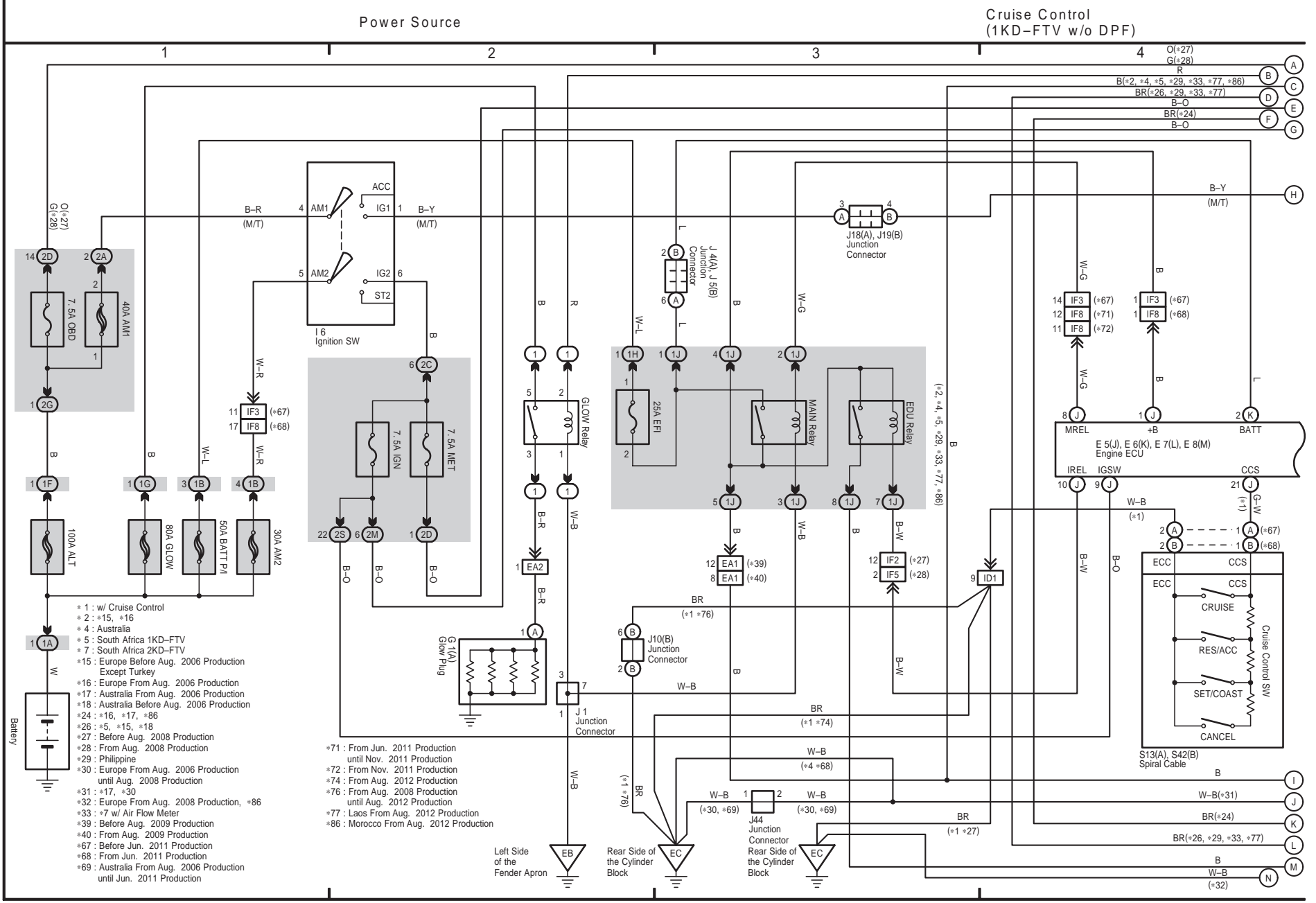

Engine Control (1KD-FTV w/o DPF, 2KD-FTV Except VN Turbocharger)

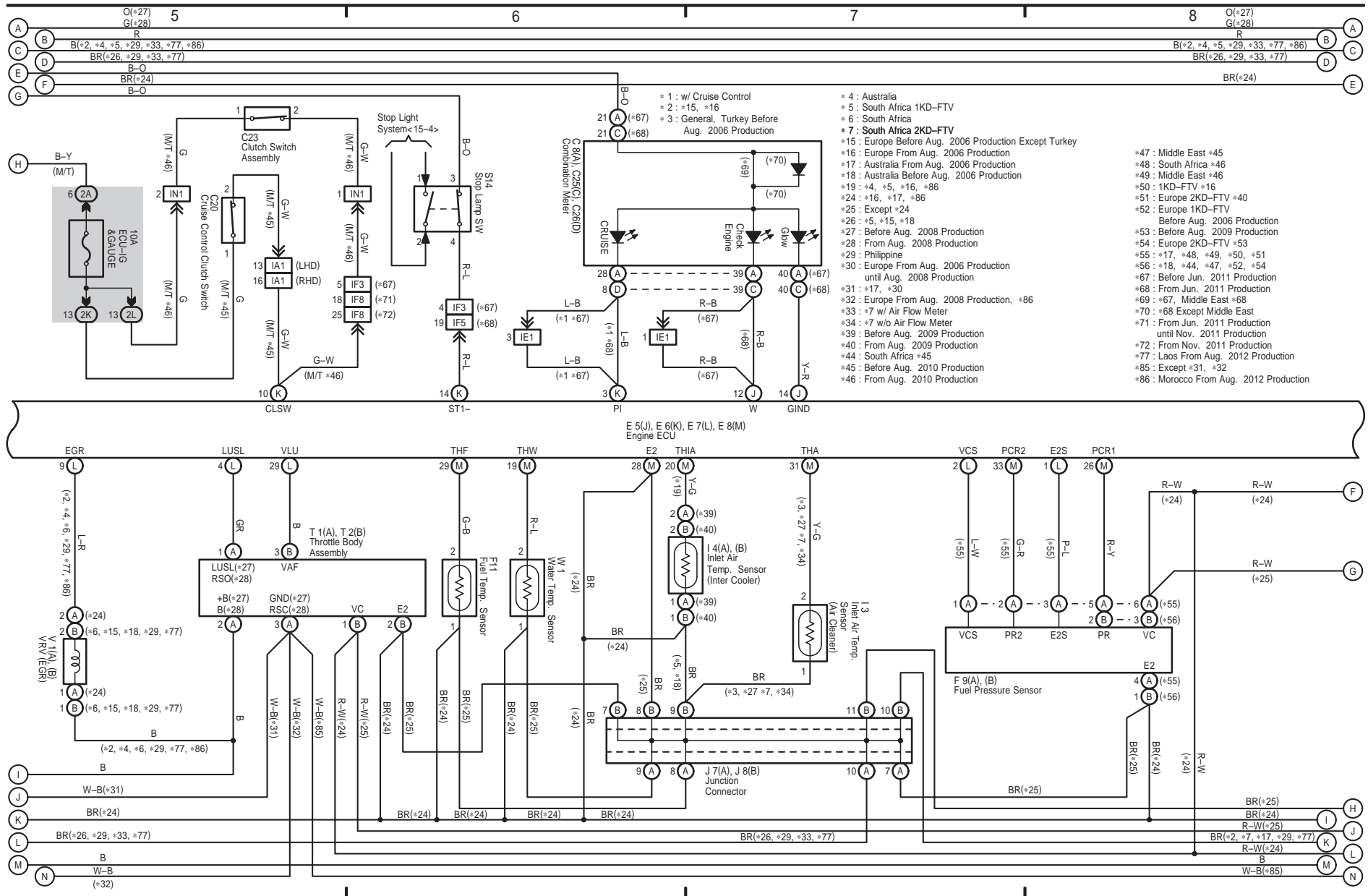

HILUX (EM1815E)

cardiagn.com

Engine Control (1KD-FTV w/o DPF, 2KD-FTV Except VN Turbocharger)

HILUX (EM1815E)

M OVERALL ELECTRICAL WIRING DIAGRAM

cardipart.com

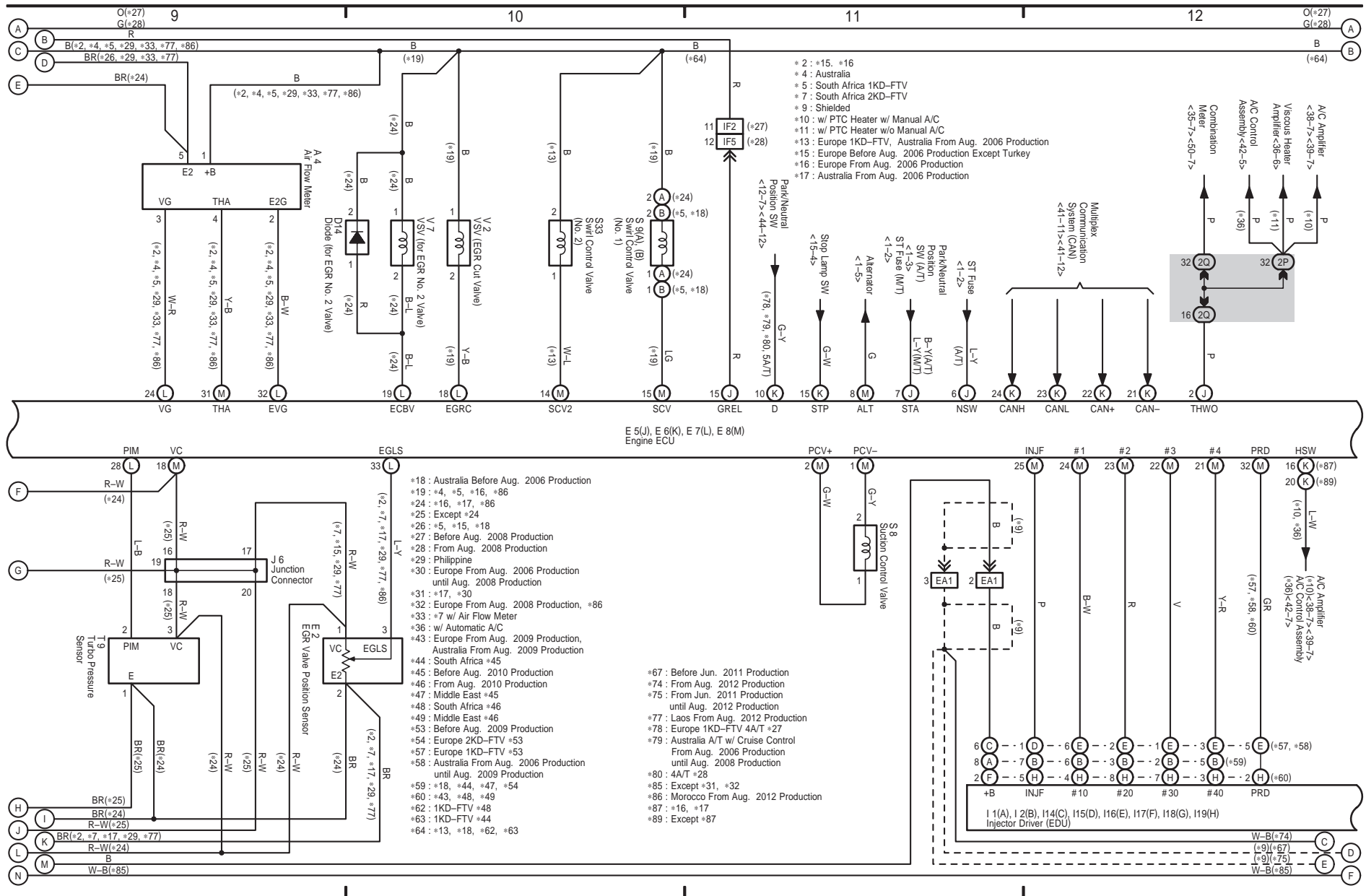

Engine Control (1KD-FTV w/o DPF, 2KD-FTV Except VN Turbocharger)

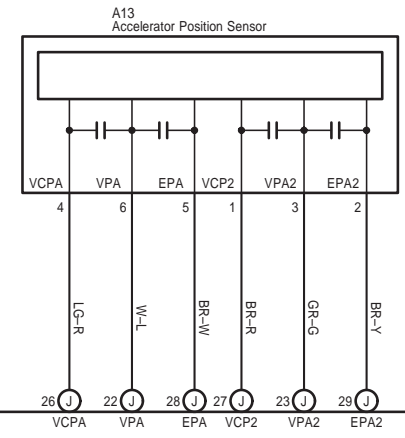
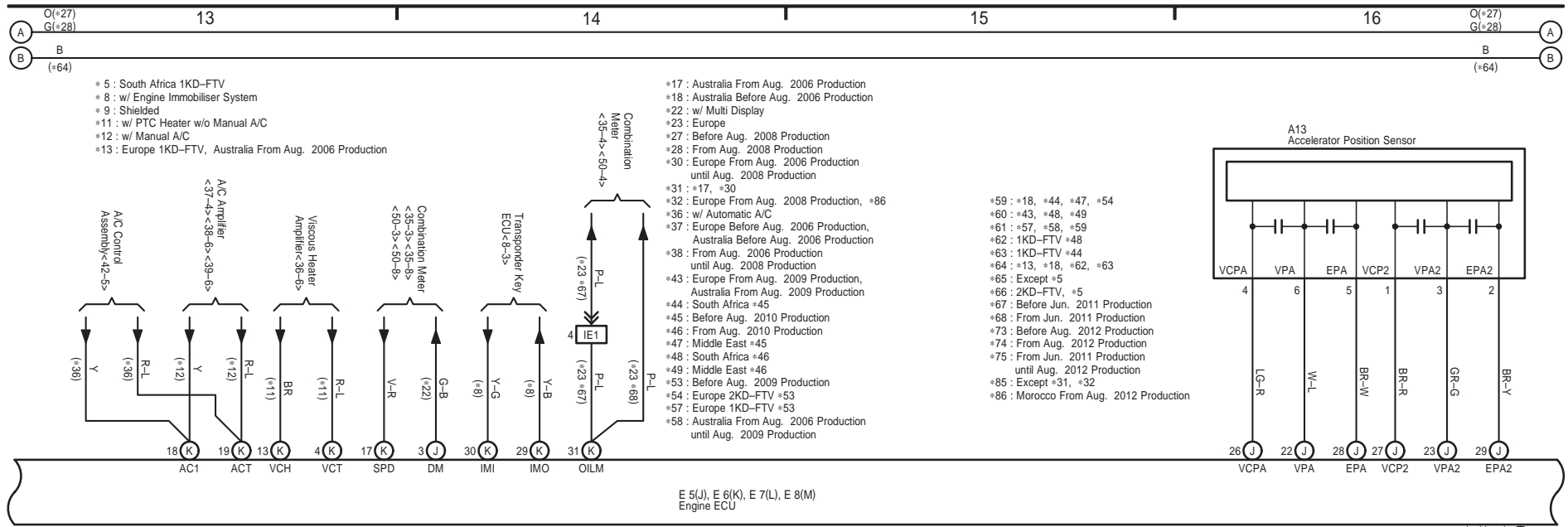

HILUX (EM1815E)

cardiagn.com

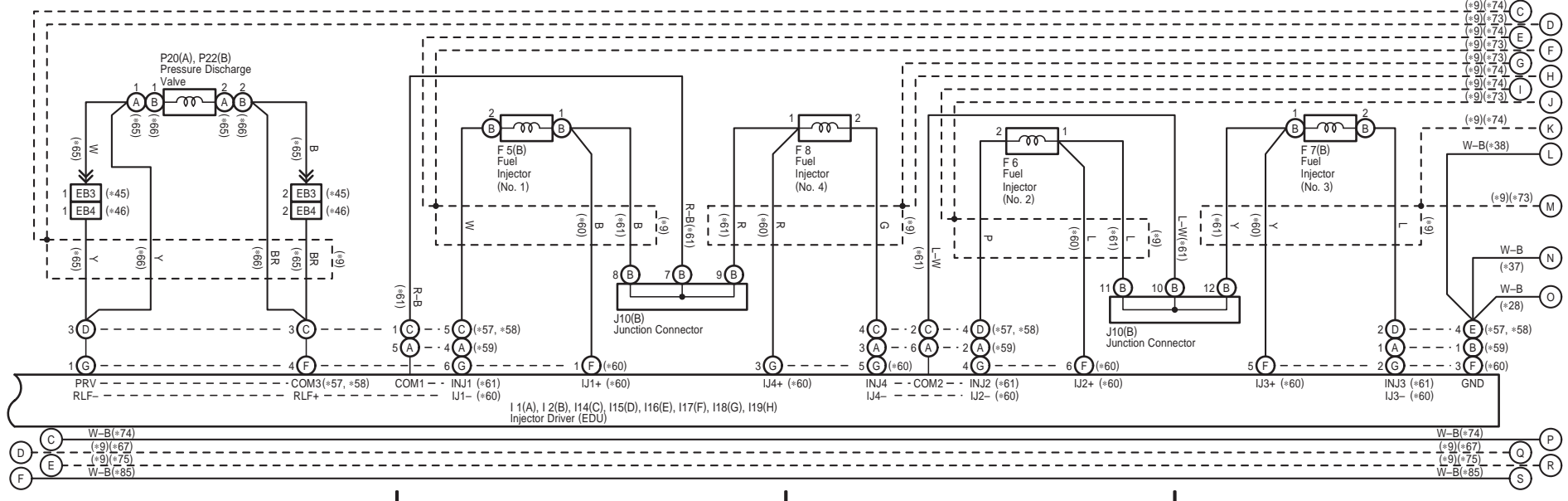

Engine Control (1KD-FTV w/o DPF, 2KD-FTV Except VN Turbocharger)

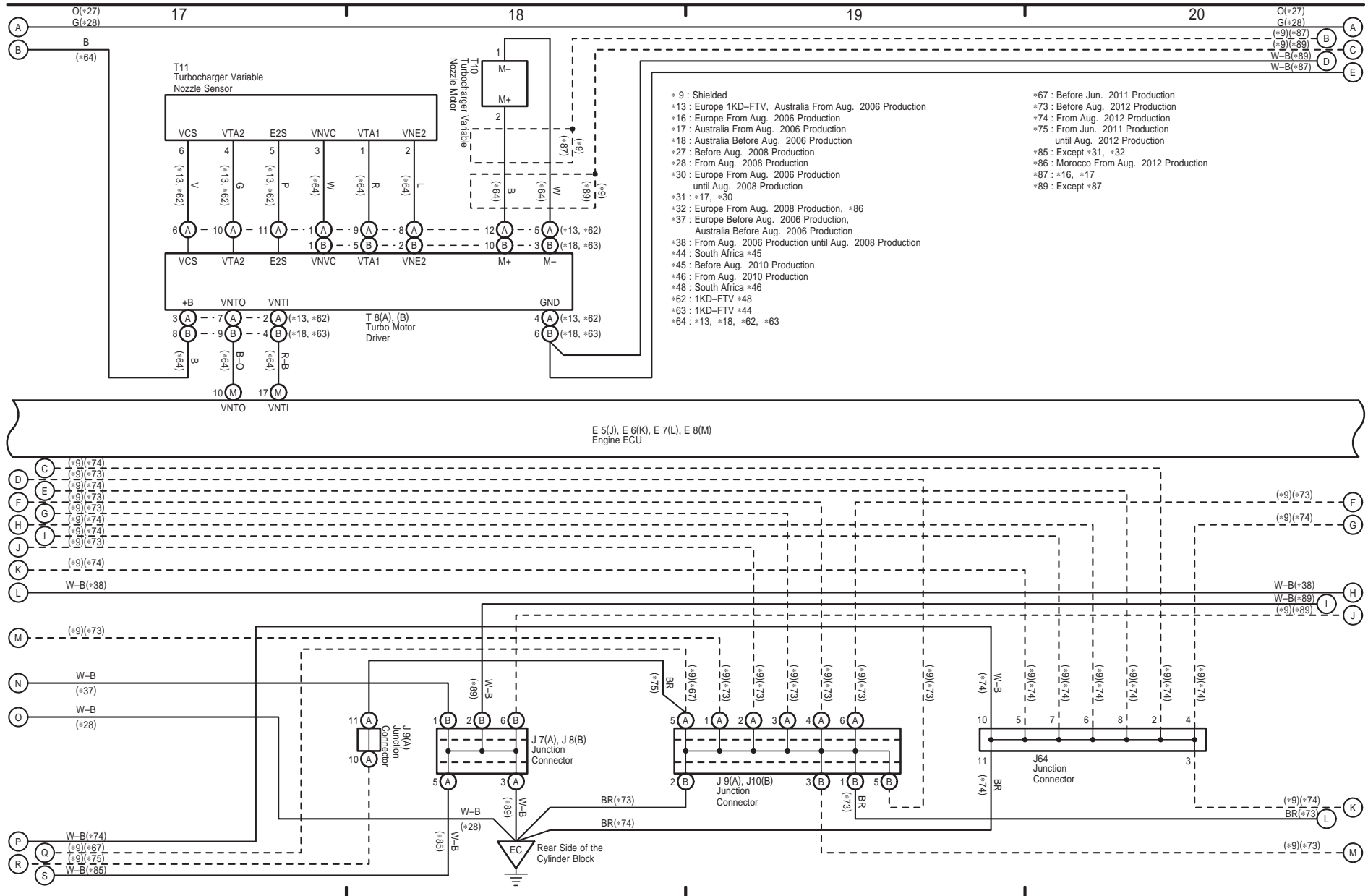

- * 9 : Shielded
- *13 : Europe 1KD-FTV, Australia From Aug. 2006 Production
- *16 : Europe From Aug. 2006 Production
- *17 : Australia From Aug. 2006 Production
- *18 : Australia Before Aug. 2006 Production
- *27 : Before Aug. 2008 Production
- *28 : From Aug. 2008 Production
- *30 : Europe From Aug. 2006 Production until Aug. 2008 Production
- *31 : *17, *30
- *32 : Europe From Aug. 2008 Production, *86
- *37 : Europe Before Aug. 2006 Production, Australia Before Aug. 2006 Production
- *38 : From Aug. 2006 Production until Aug. 2008 Production
- *44 : South Africa *45
- *45 : Before Aug. 2010 Production
- *46 : From Aug. 2010 Production
- *48 : South Africa *46
- *62 : 1KD-FTV *48
- *63 : 1KD-FTV *44
- *64 : +13, +18, +62, +63
- *67 : Before Jun. 2011 Production
- *73 : Before Aug. 2012 Production
- *74 : From Aug. 2012 Production
- *75 : From Jun. 2011 Production until Aug. 2012 Production
- *85 : Except *31, *32
- *86 : Morocco From Aug. 2012 Production
- *87 : *16, *17
- *89 : Except *87

HILUX (EM1815E)

M OVERALL ELECTRICAL WIRING DIAGRAM

cardiagn.com

6 HILUX (Cont' d)

Engine Control (1KD-FTV w/o DPF, 2KD-FTV Except VN Turbocharger)

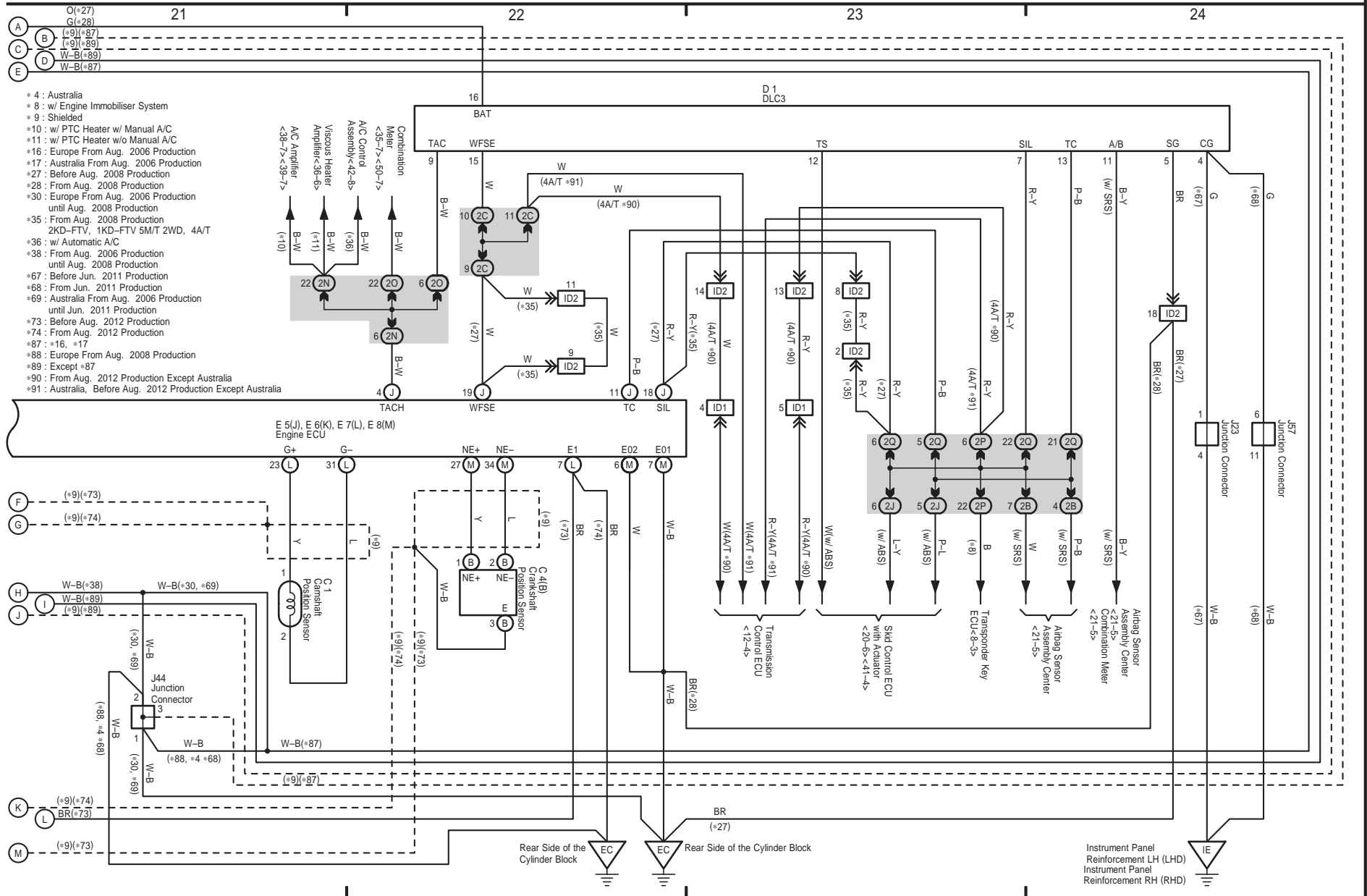

- * 4 : Australia
- * 8 : w/ Engine Immobiliser System
- * 9 : Shielded
- * 10 : w/ PTC Heater w/ Manual A/C
- * 11 : w/ PTC Heater w/o Manual A/C
- * 16 : Europe From Aug. 2006 Production
- * 17 : Australia From Aug. 2006 Production
- * 27 : Before Aug. 2008 Production
- * 28 : From Aug. 2008 Production
- * 30 : Europe From Aug. 2006 Production until Aug. 2008 Production
- * 35 : From Aug. 2008 Production 2KD-FTV, 1KD-FTV 5M/T 2WD, 4A/T
- * 36 : w/ Automatic A/C
- * 38 : From Aug. 2006 Production until Aug. 2008 Production
- * 67 : Before Jun. 2011 Production
- * 68 : From Jun. 2011 Production
- * 69 : Australia From Aug. 2006 Production until Jun. 2011 Production
- * 73 : Before Aug. 2012 Production
- * 74 : From Aug. 2012 Production
- * 87 : *16, *17
- * 88 : Europe From Aug. 2008 Production
- * 89 : Except *87
- * 90 : From Aug. 2012 Production Except Australia
- * 91 : Australia, Before Aug. 2012 Production Except Australia

HILUX (EM1815E)

cardiagn.com

HILUX (EM1815E)

M OVERALL ELECTRICAL WIRING DIAGRAM

cardiagn.com

Power Source

Engine Control (5L-E)

- * 1 : Before Aug. 2008 Production
- * 2 : From Aug. 2008 Production
- * 4 : From Aug. 2009 Production
- * 5 : Before Aug. 2009 Production

- O(+1)
- G(-2)
- R
- L
- B-O

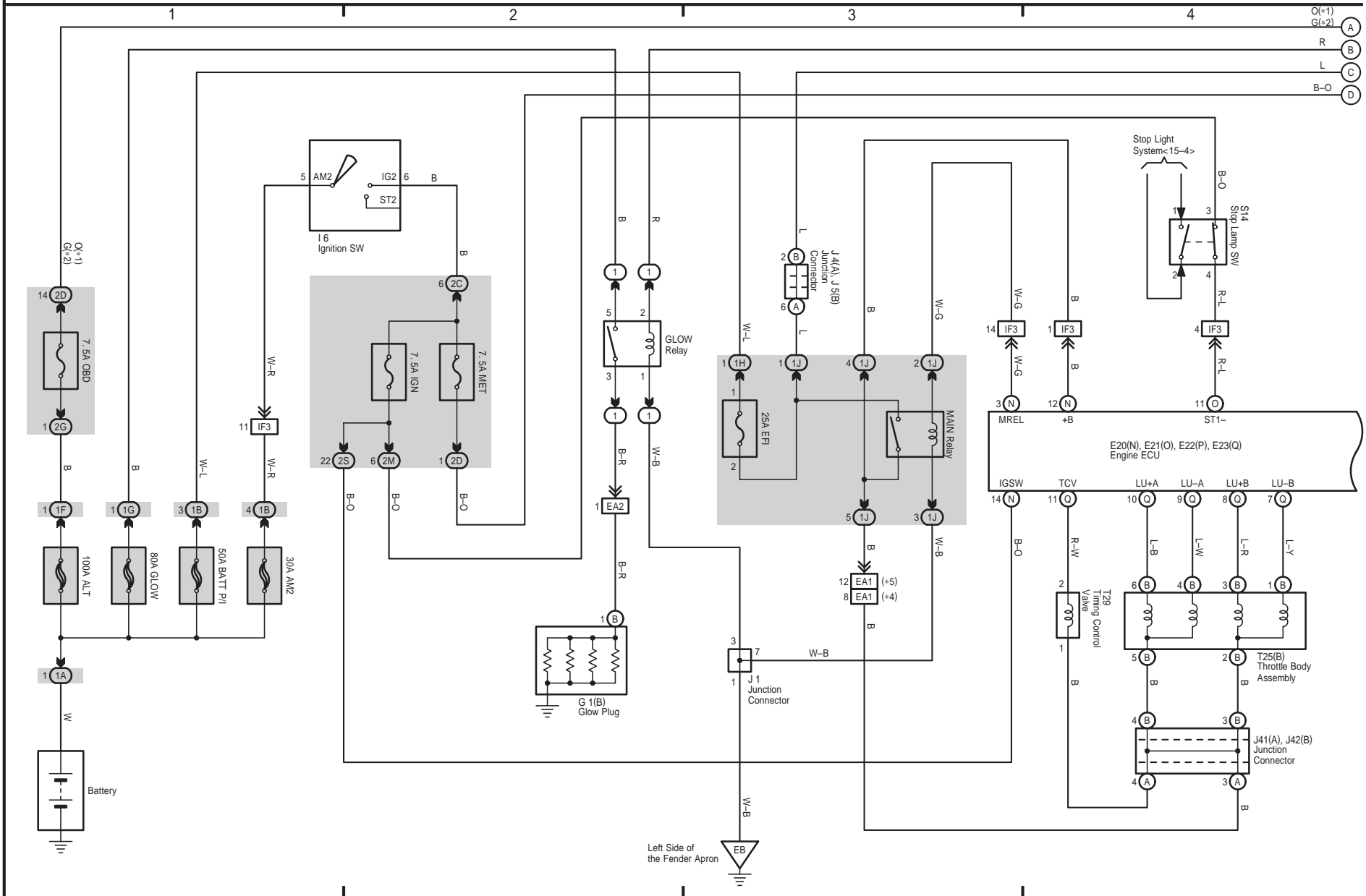

Left Side of the Fender Apron

Engine Control (5L-E)

- * 1 : Before Aug. 2008 Production
- * 2 : From Aug. 2008 Production
- * 6 : Before Jun. 2011 Production
- * 7 : From Jun. 2011 Production

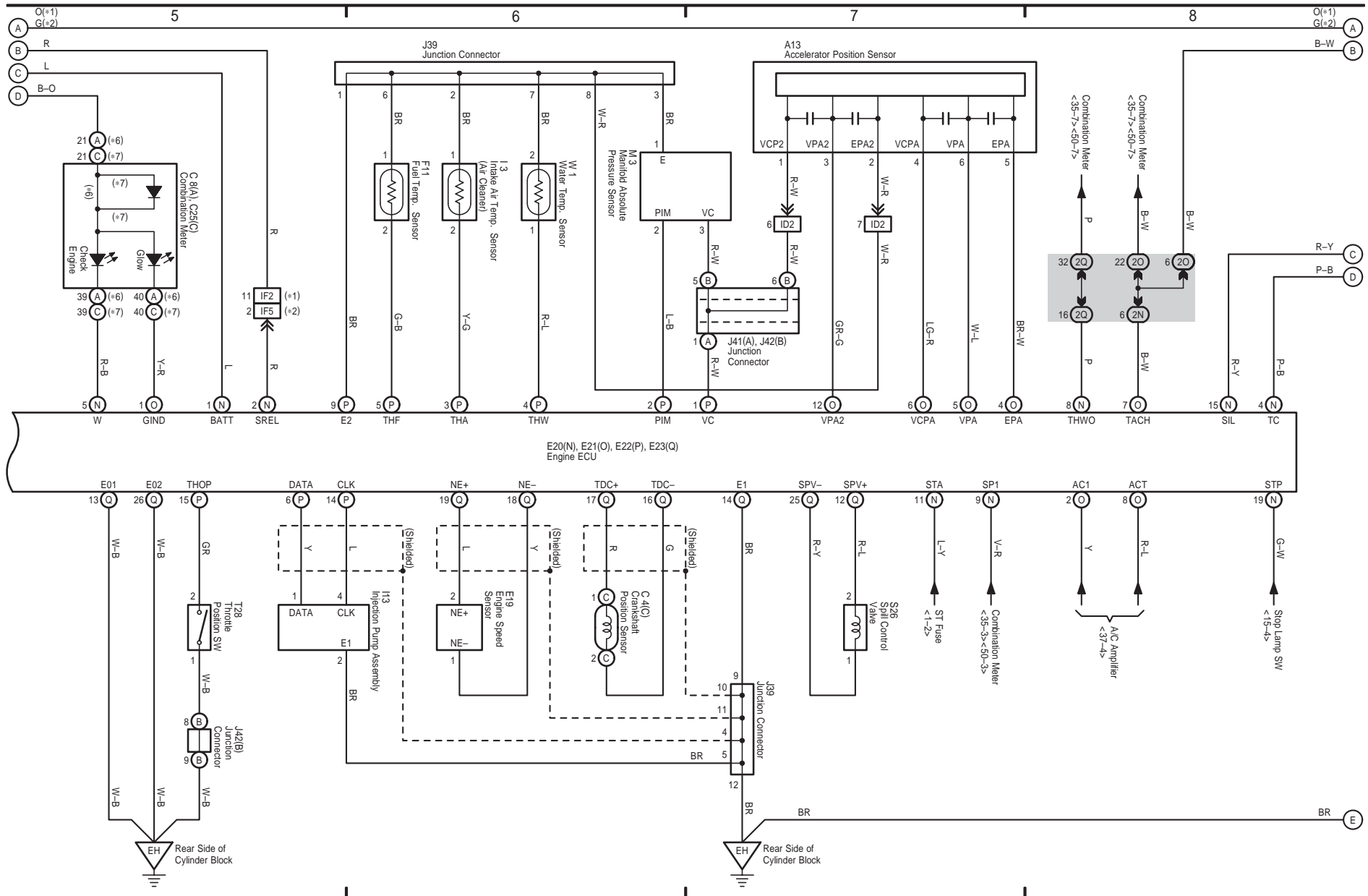

HILUX (EM1815E)

cardiagn.com

Power Source

Engine Immobiliser System

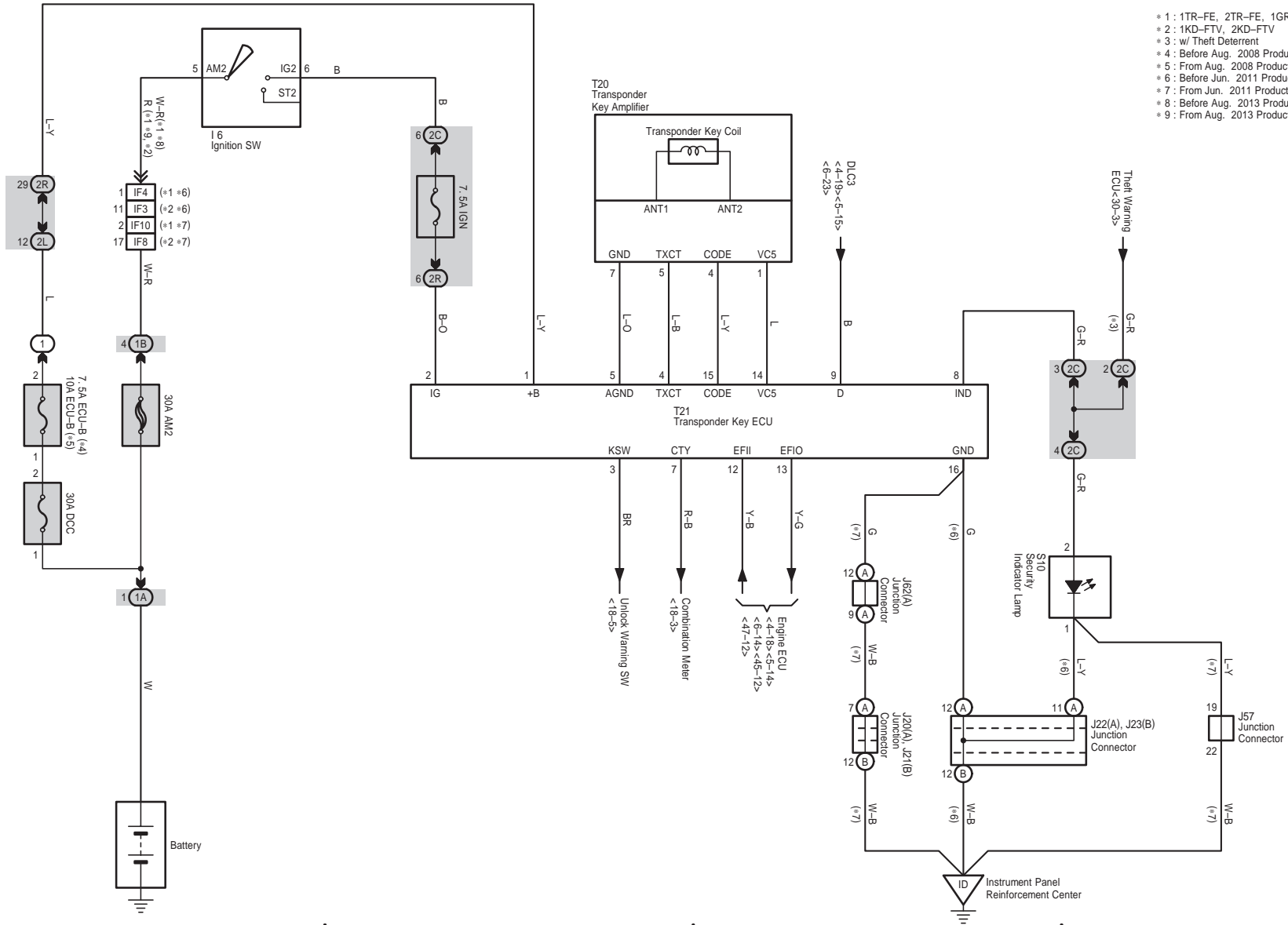

- * 1 : 1TR-FE, 2TR-FE, 1GR-FE
- * 2 : 1KD-FTV, 2KD-FTV
- * 3 : w/ Theft Deterrent
- * 4 : Before Aug. 2008 Production
- * 5 : From Aug. 2008 Production
- * 6 : Before Jun. 2011 Production
- * 7 : From Jun. 2011 Production
- * 8 : Before Aug. 2013 Production
- * 9 : From Aug. 2013 Production

9 HILUX (Cont' d)

4WD (1GR-FE, 2TR-FE)

5 6 7 8

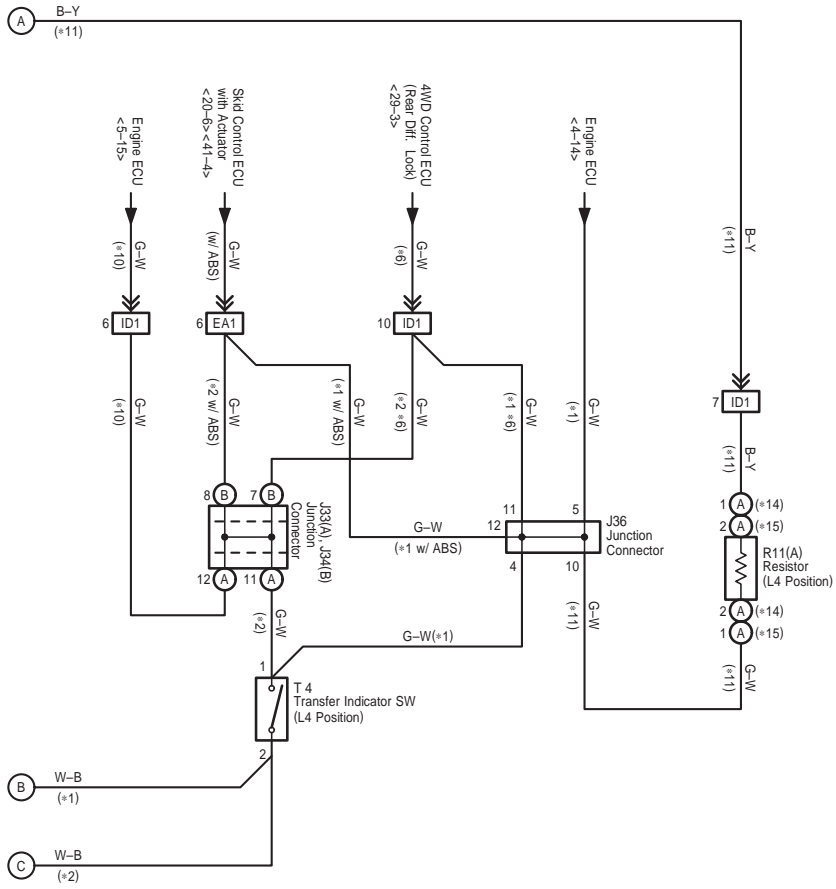

- * 1 : 1GR-FE
- * 2 : 2TR-FE
- * 6 : w/ Rear Diff. Lock
- * 10 : 2TR-FE A/T, 2TR-FE M/T Before Jun. 2011 Production
- * 11 : 1GR-FE M/T w/ ADD From Jun. 2011 Production
- * 14 : Before Nov. 2011 Production
- * 15 : From Nov. 2011 Production

HILUX (EM1815E)

Power Source

4WD
(1KD-FTV, 2KD-FTV, 5L-E)

- * 1 : 1KD-FTV, 2KD-FTV
- * 2 : 5L-E
- * 3 : w/ ADD
- * 4 : w/o ADD
- * 6 : Europe From Aug. 2006 Production, Australia From Aug. 2006 Production
- * 7 : Except *6
- * 12 : Europe 1KD-FTV M/T *24, Europe 2KD-FTV M/T *24

HILUX (EM1815E)

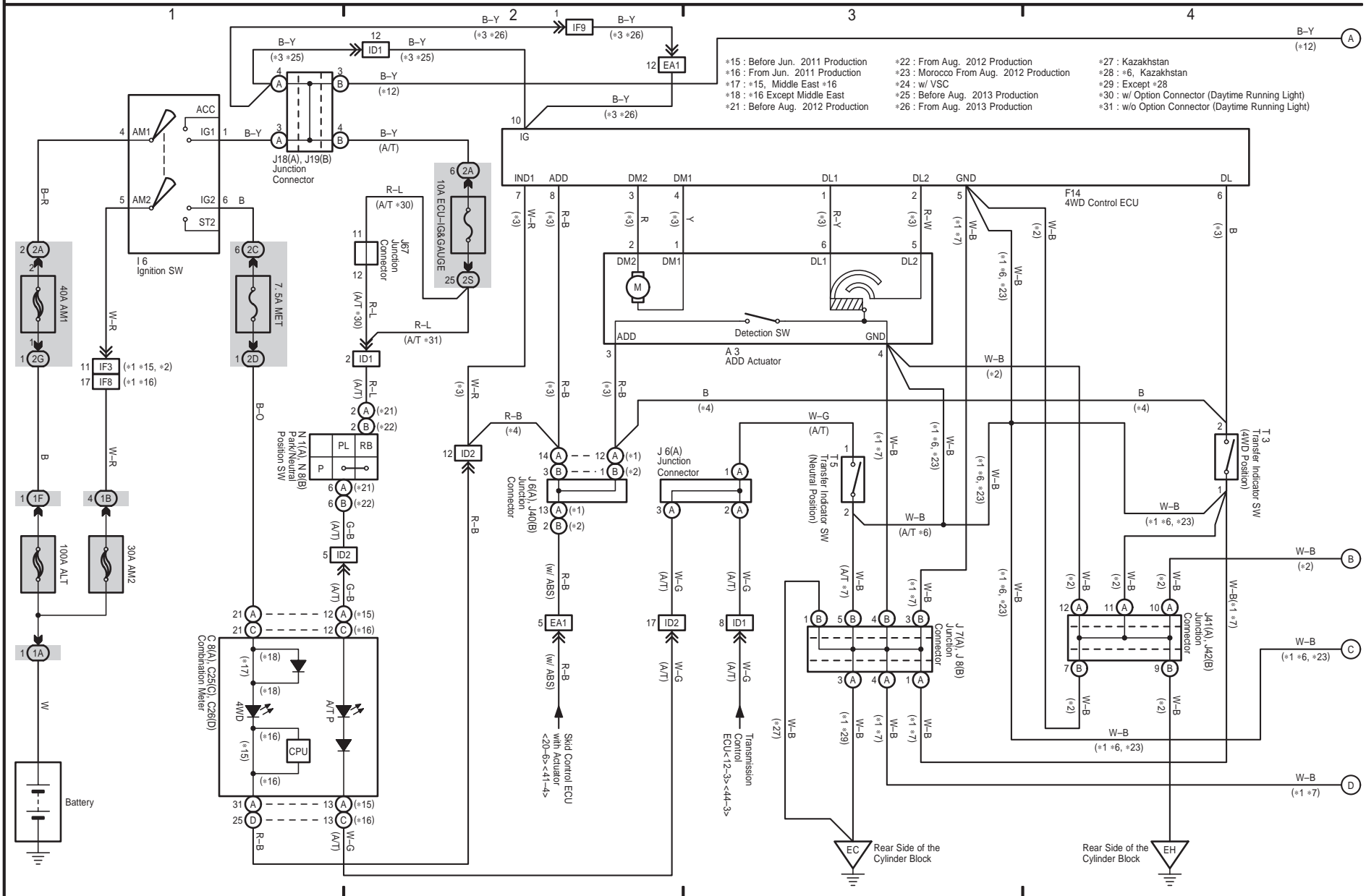

- * 15 : Before Jun. 2011 Production
- * 16 : From Jun. 2011 Production
- * 17 : *15, Middle East *16
- * 18 : *16 Except Middle East
- * 21 : Before Aug. 2012 Production
- * 22 : From Aug. 2012 Production
- * 23 : Morocco From Aug. 2012 Production
- * 24 : w/ VSC
- * 25 : Before Aug. 2013 Production
- * 26 : From Aug. 2013 Production
- * 27 : Kazakhstan
- * 28 : *6, Kazakhstan
- * 29 : Except *28
- * 30 : w/ Option Connector (Daytime Running Light)
- * 31 : w/o Option Connector (Daytime Running Light)

M OVERALL ELECTRICAL WIRING DIAGRAM

cardiagn.com

10 HILUX (Cont' d)

4WD (1KD-FTV, 2KD-FTV, 5L-E)

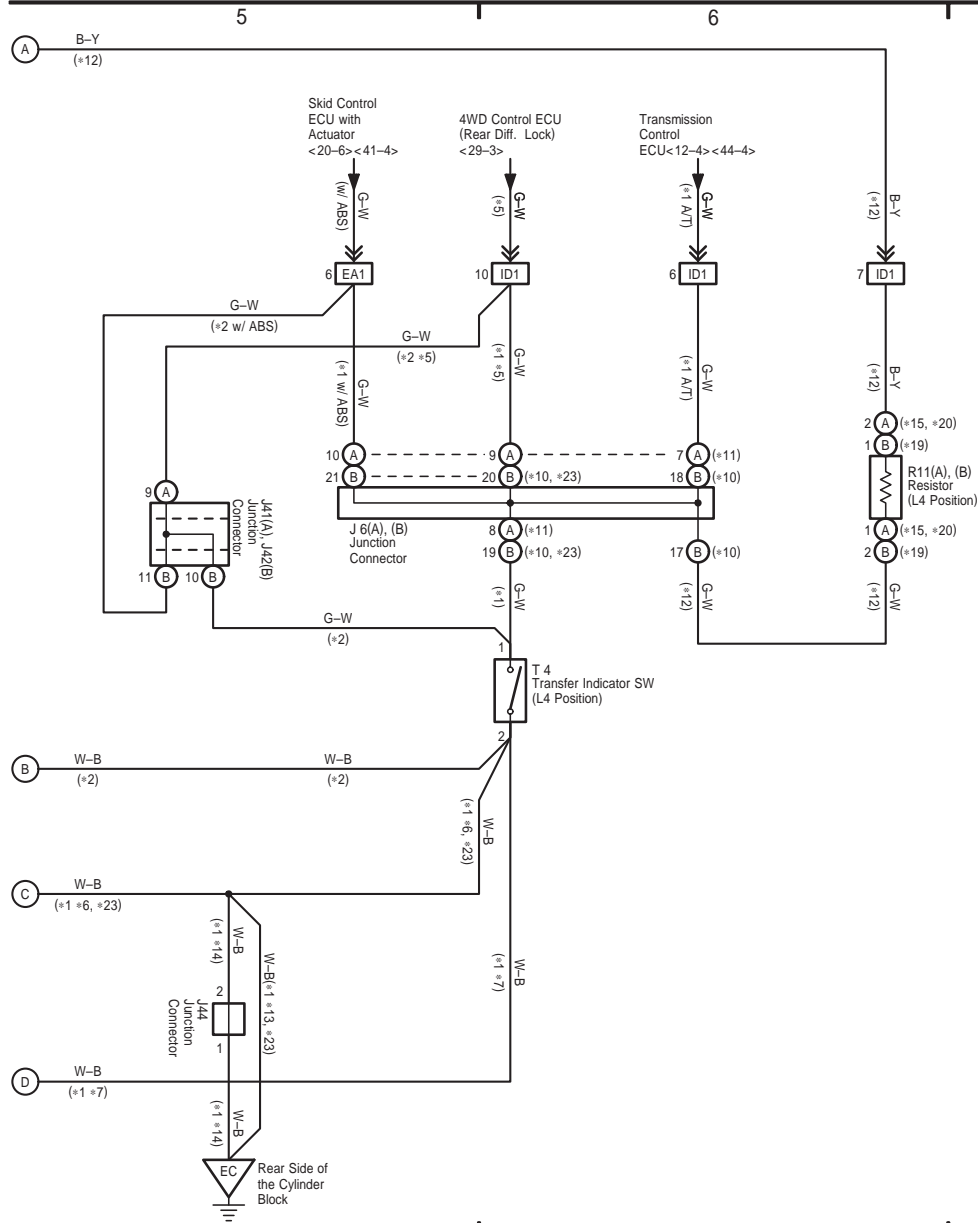

- *1 : 1KD-FTV, 2KD-FTV
- *2 : 5L-E
- *5 : w/ Rear Diff. Lock
- *6 : Europe From Aug. 2006 Production, Australia From Aug. 2006 Production
- *7 : Except *6
- *10 : Europe From Aug. 2008 Production, Australia From Aug. 2008 Production
- *11 : Except *10
- *12 : Europe 1KD-FTV M/T *24, Europe 2KD-FTV M/T *24
- *13 : Europe From Aug. 2008 Production, Australia From Jun. 2011 Production
- *14 : Europe From Aug. 2006 Production until Aug. 2008 Production, Australia From Aug. 2006 Production until Jun. 2011 Production
- *15 : Before Jun. 2011 Production
- *19 : From Jun. 2011 Production until Nov. 2011 Production
- *20 : From Nov. 2011 Production
- *23 : Morocco From Aug. 2012 Production
- *24 : w/ VSC

HILUX (EM1815E)

cardiagn.com

ECT and A/T Indicator (1GR-FE)

* 2 : Before Aug. 2008 Production
 * 3 : From Aug. 2008 Production

HILUX (EM1815E)

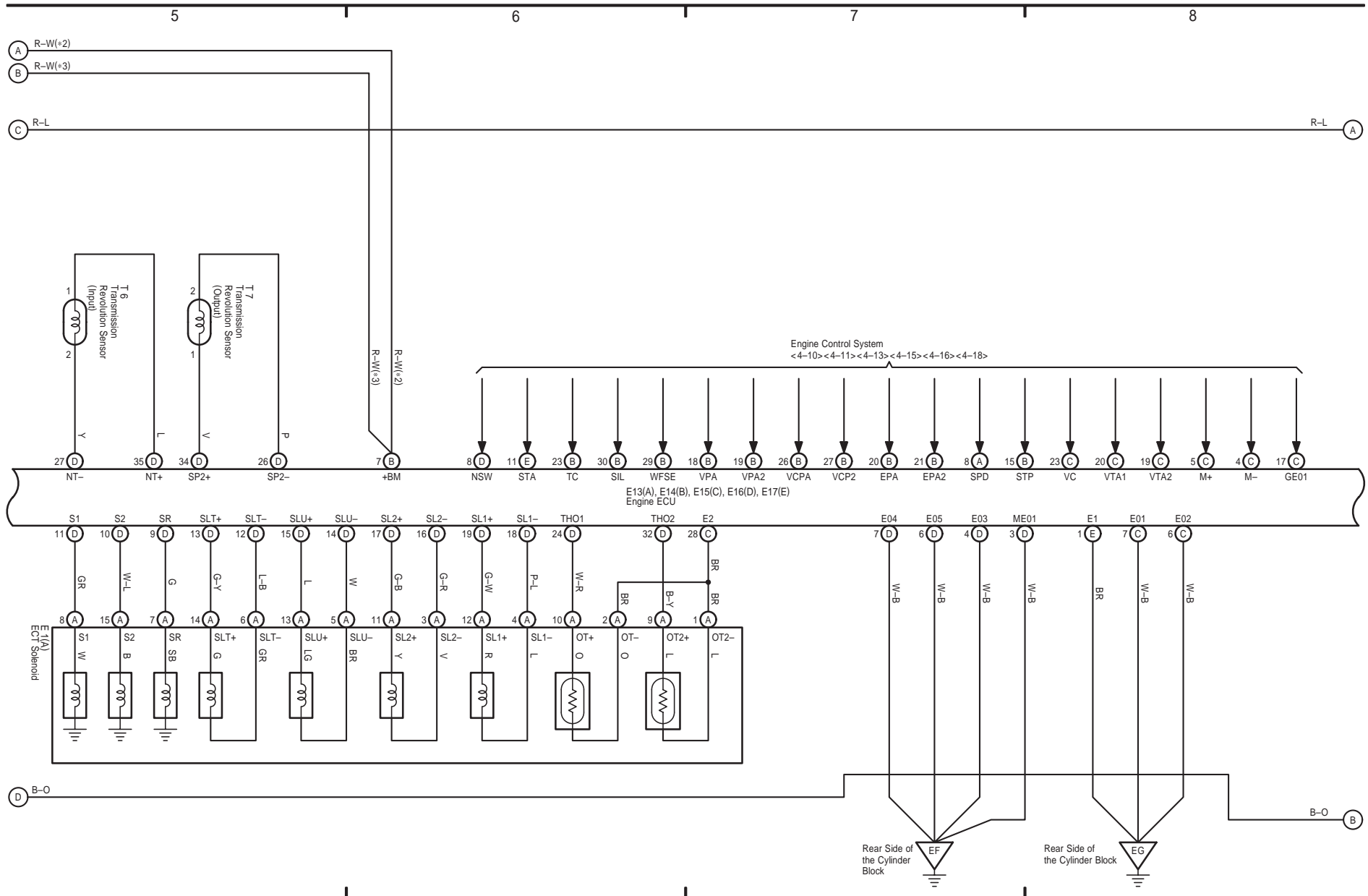

11 HILUX (Cont' d)

ECT and A/T Indicator (1GR-FE)

- * 1 : w/ A/T Indicator Light
- * 2 : Before Aug. 2008 Production
- * 3 : From Aug. 2008 Production
- * 4 : Before Aug. 2010 Production

- * 5 : From Aug. 2010 Production
- * 6 : Before Jun. 2011 Production
- * 7 : From Jun. 2011 Production
- * 8 : Before Aug. 2012 Production
- * 9 : From Aug. 2012 Production

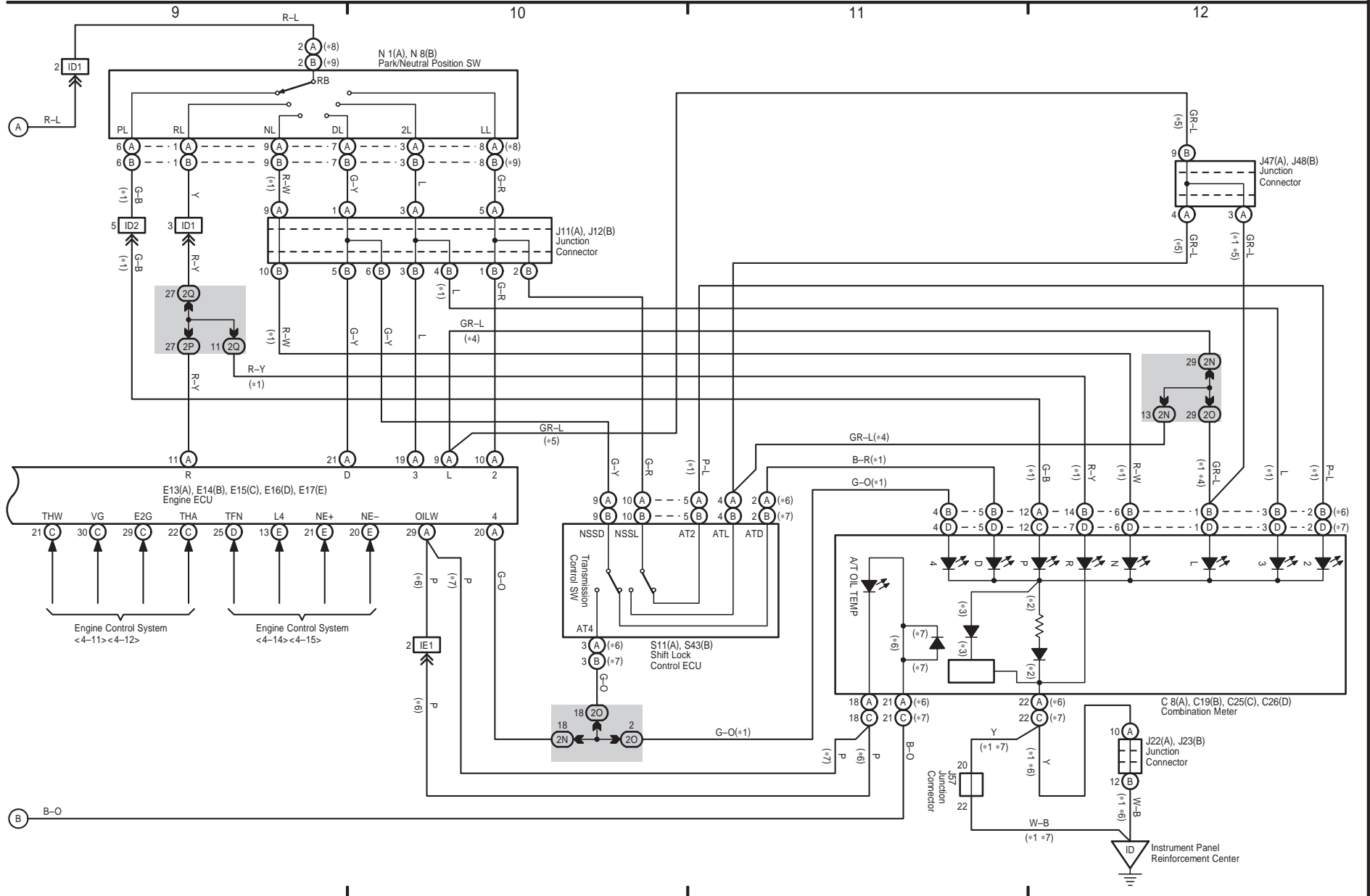

HILUX (EM1815E)

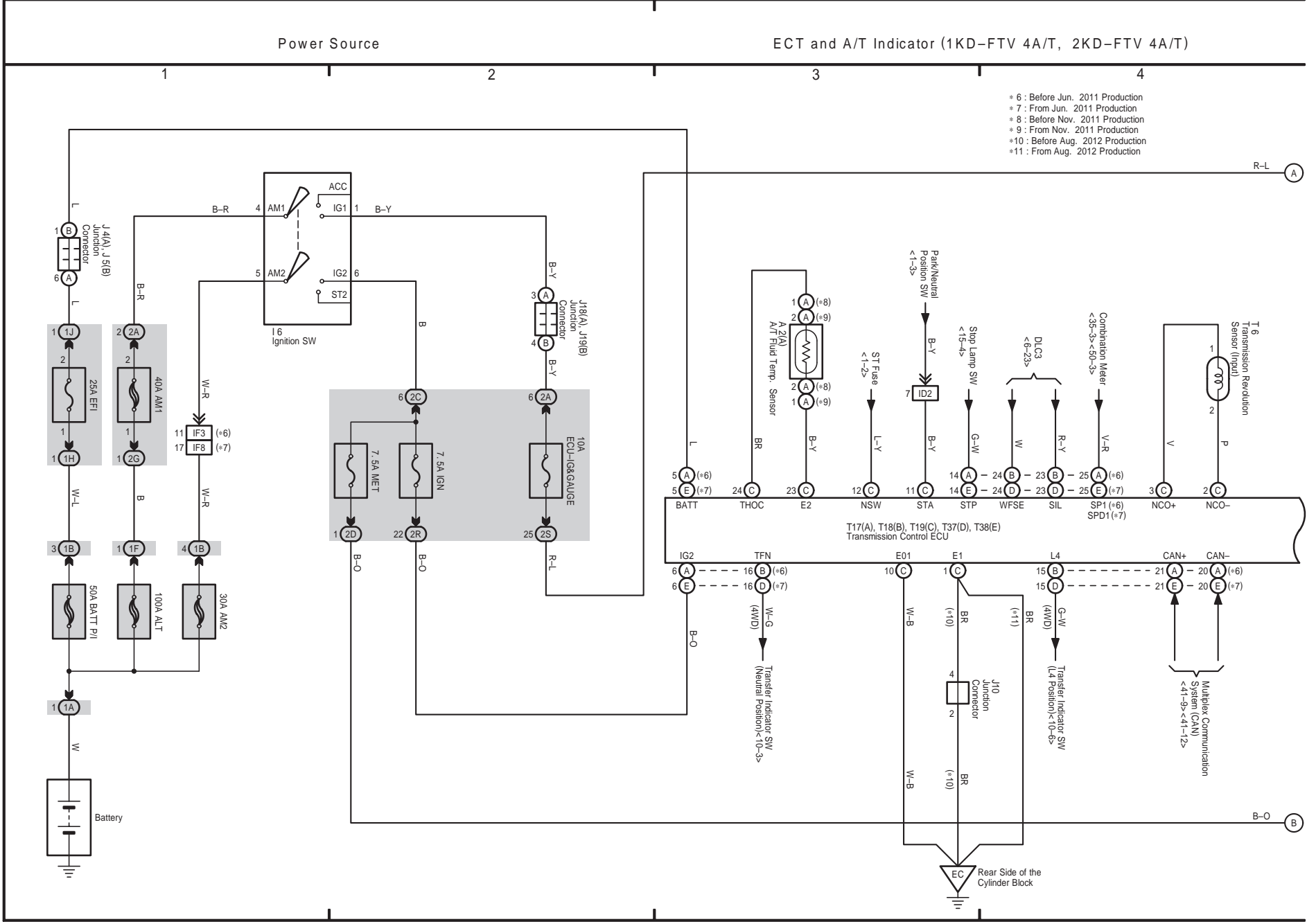

ECT and A/T Indicator (1KD-FTV 4A/T, 2KD-FTV 4A/T)

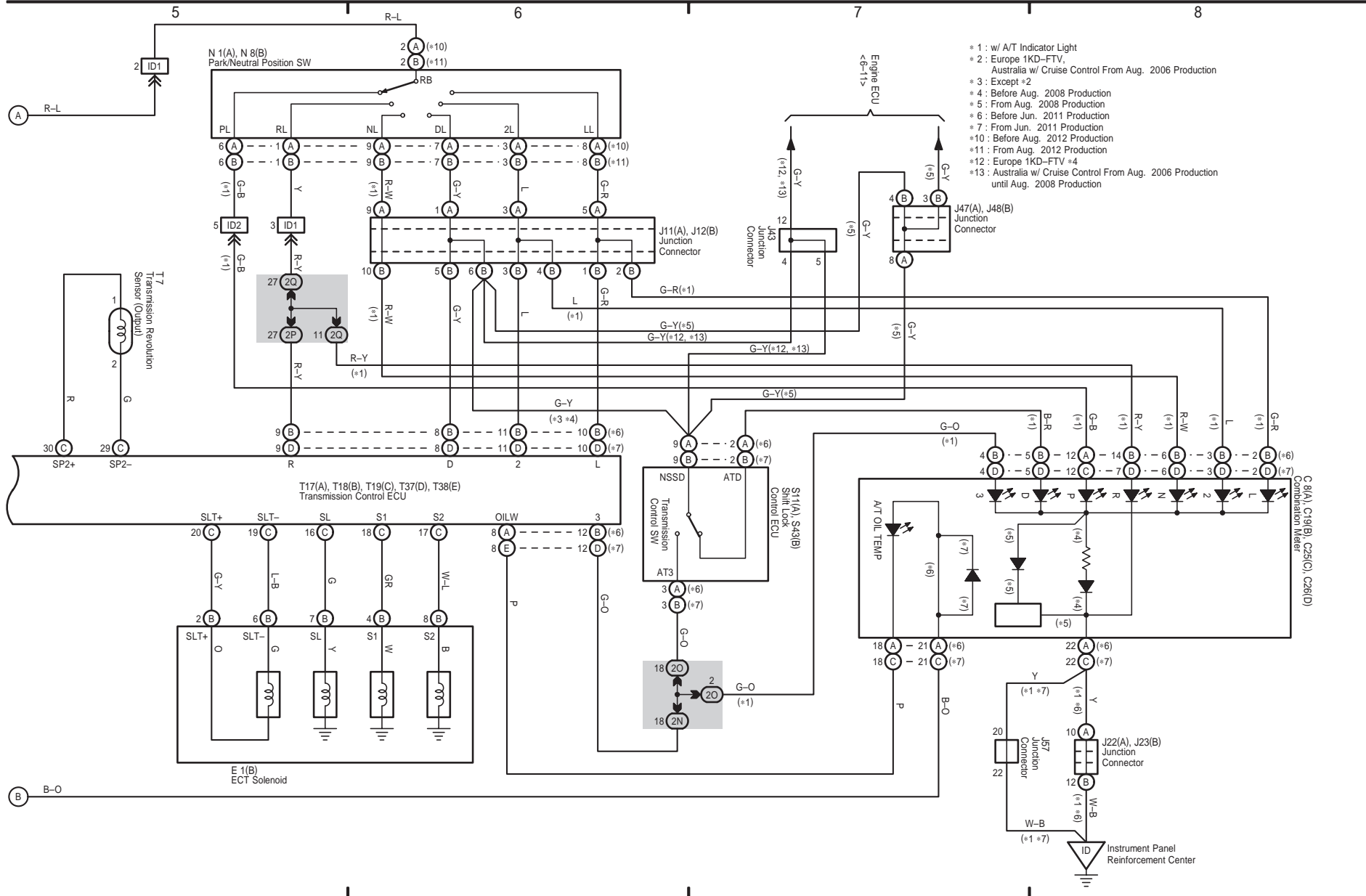

- * 1 : w/ A/T Indicator Light
- * 2 : Europe 1KD-FTV, Australia w/ Cruise Control From Aug. 2006 Production
- * 3 : Except #2
- * 4 : Before Aug. 2008 Production
- * 5 : From Aug. 2008 Production
- * 6 : Before Jun. 2011 Production
- * 7 : From Jun. 2011 Production
- * 10 : Before Aug. 2012 Production
- * 11 : From Aug. 2012 Production
- * 12 : Europe 1KD-FTV +4
- * 13 : Australia w/ Cruise Control From Aug. 2006 Production until Aug. 2008 Production

HILUX (EM1815E)

cardiagn.com

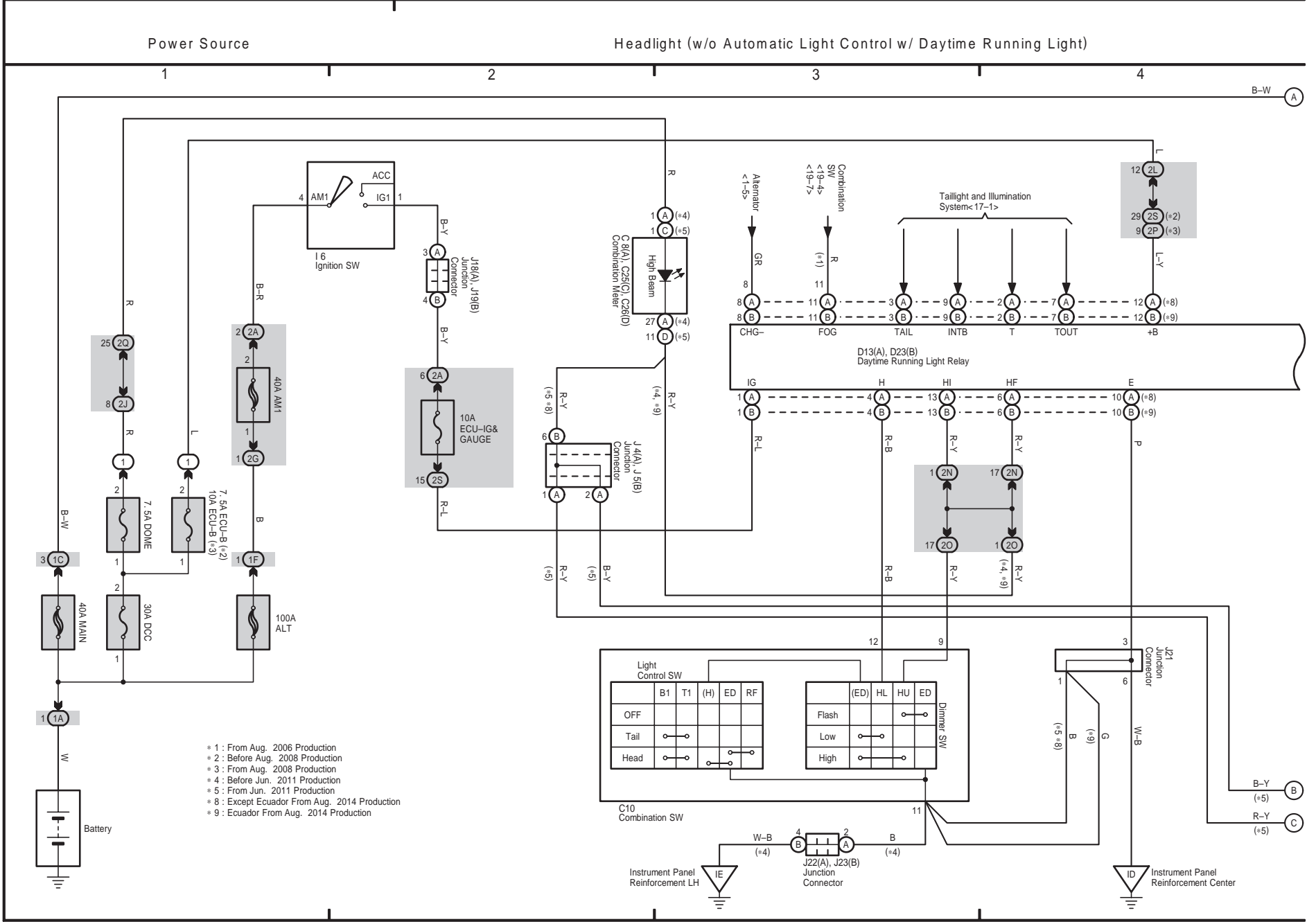

- * 1 : From Aug. 2006 Production
- * 2 : Before Aug. 2008 Production
- * 3 : From Aug. 2008 Production
- * 4 : Before Jun. 2011 Production
- * 5 : From Jun. 2011 Production
- * 8 : Except Ecuador From Aug. 2014 Production
- * 9 : Ecuador From Aug. 2014 Production

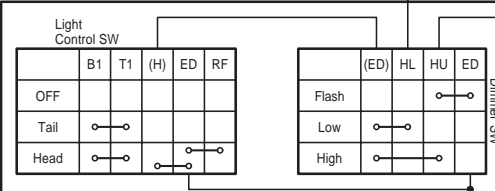

Headlight (w/o Automatic Light Control w/ Daytime Running Light)

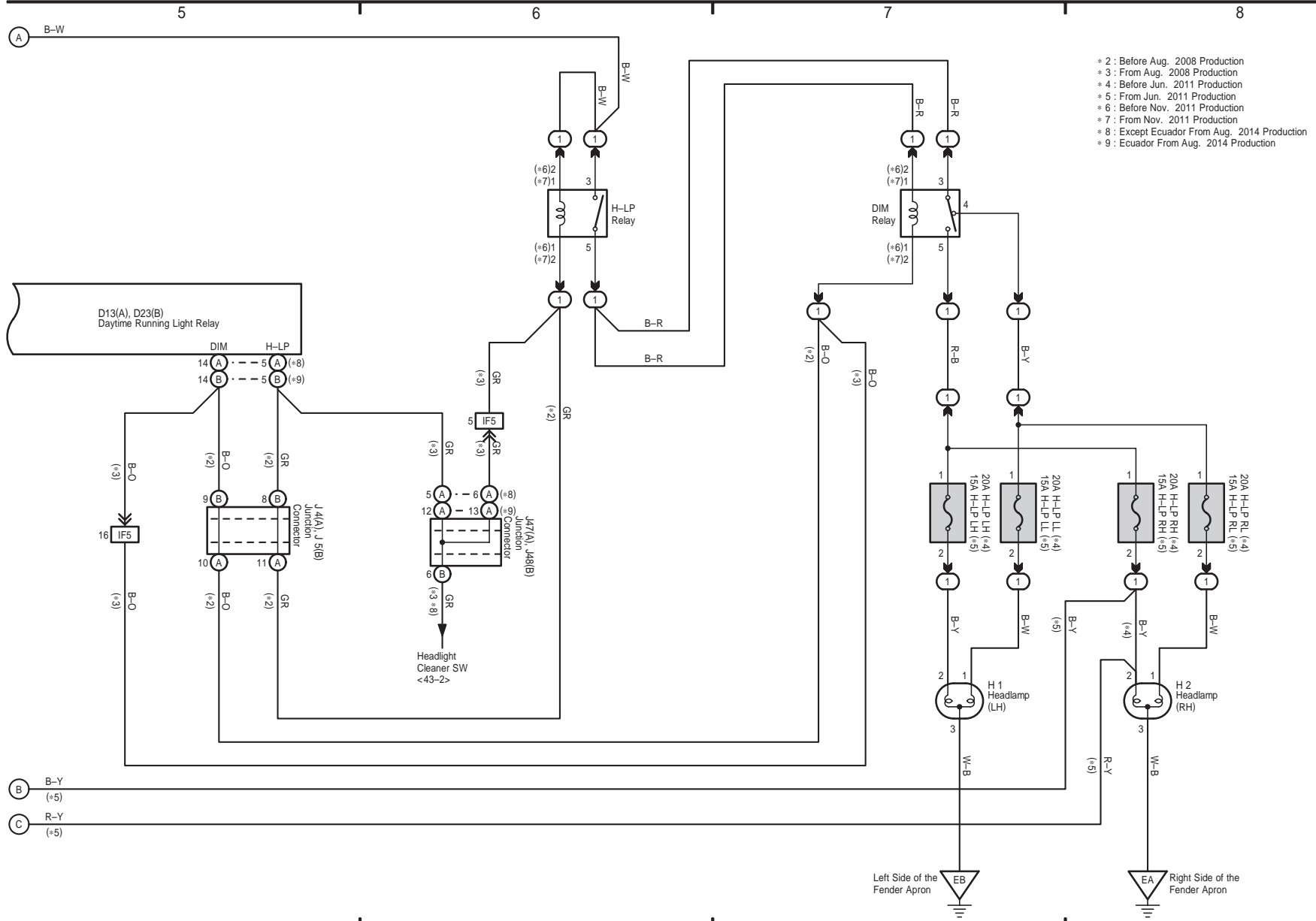

HILUX (EM1815E)

14 HILUX

HILUX (EM1815E)

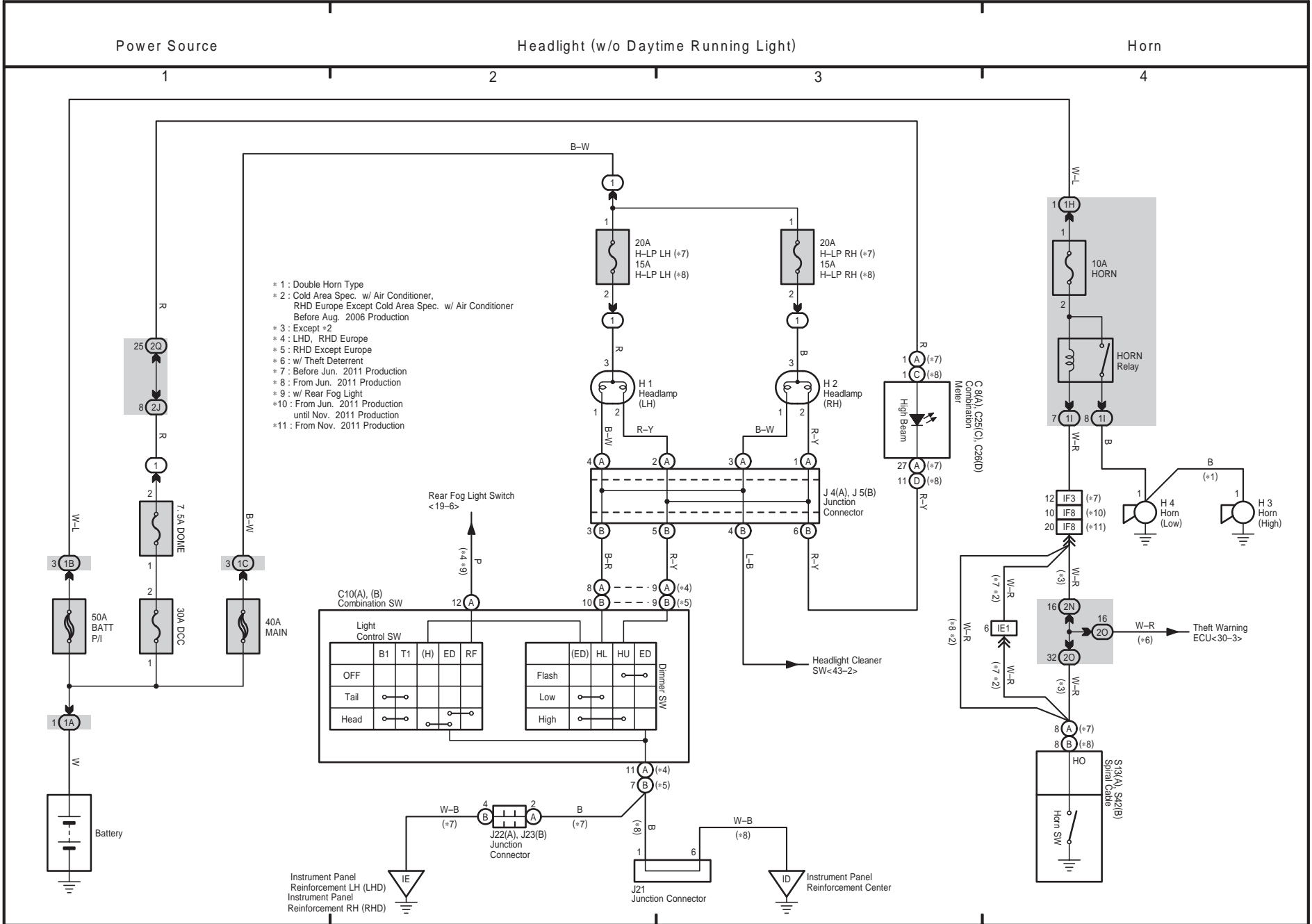

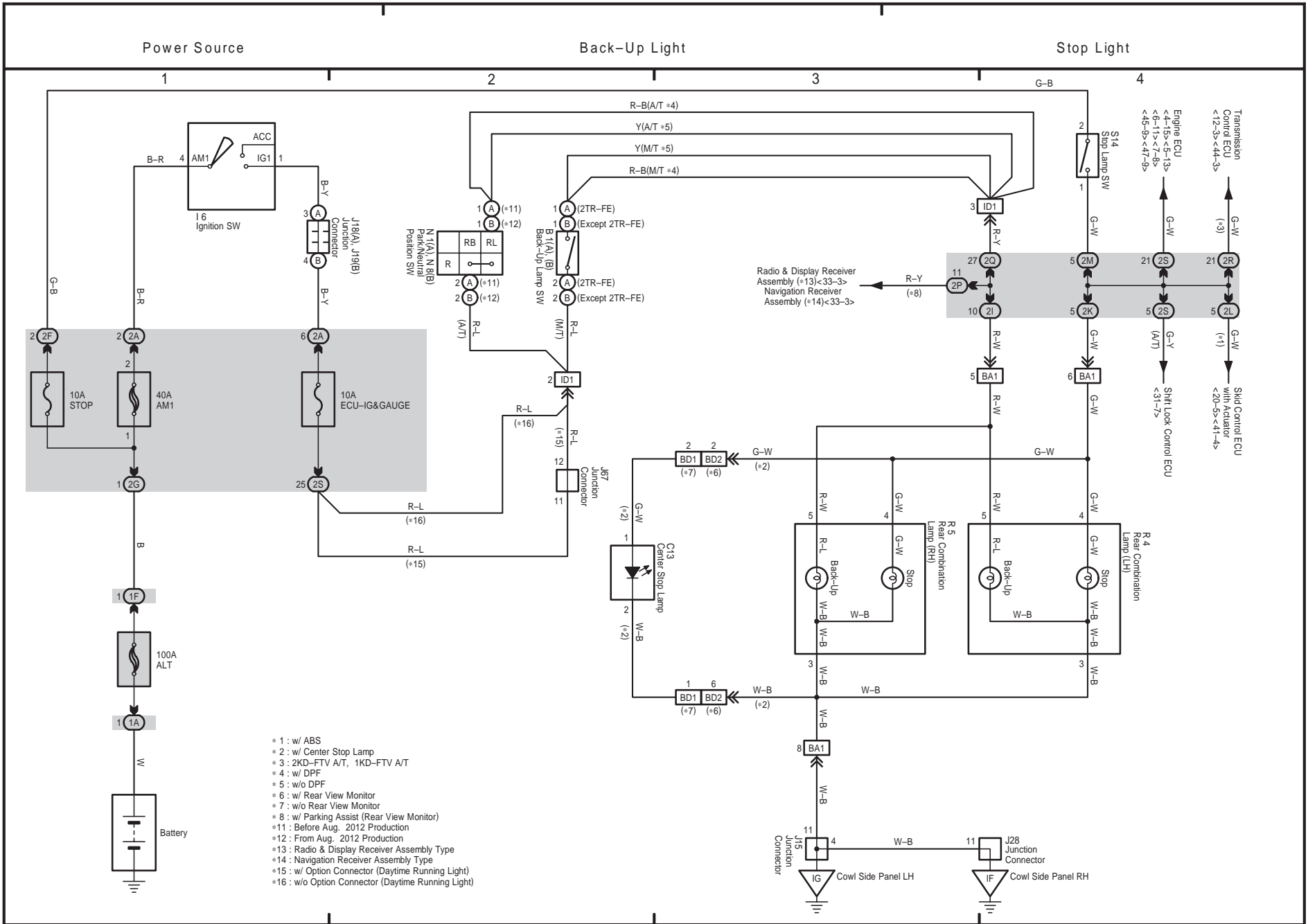

Turn Signal and Hazard Warning Light

* 7 : w/ Outer Rear View Mirror Side Turn Signal Lamp
 * 8 : Except *7

5 6 7 8

HILUX (EM1815E)

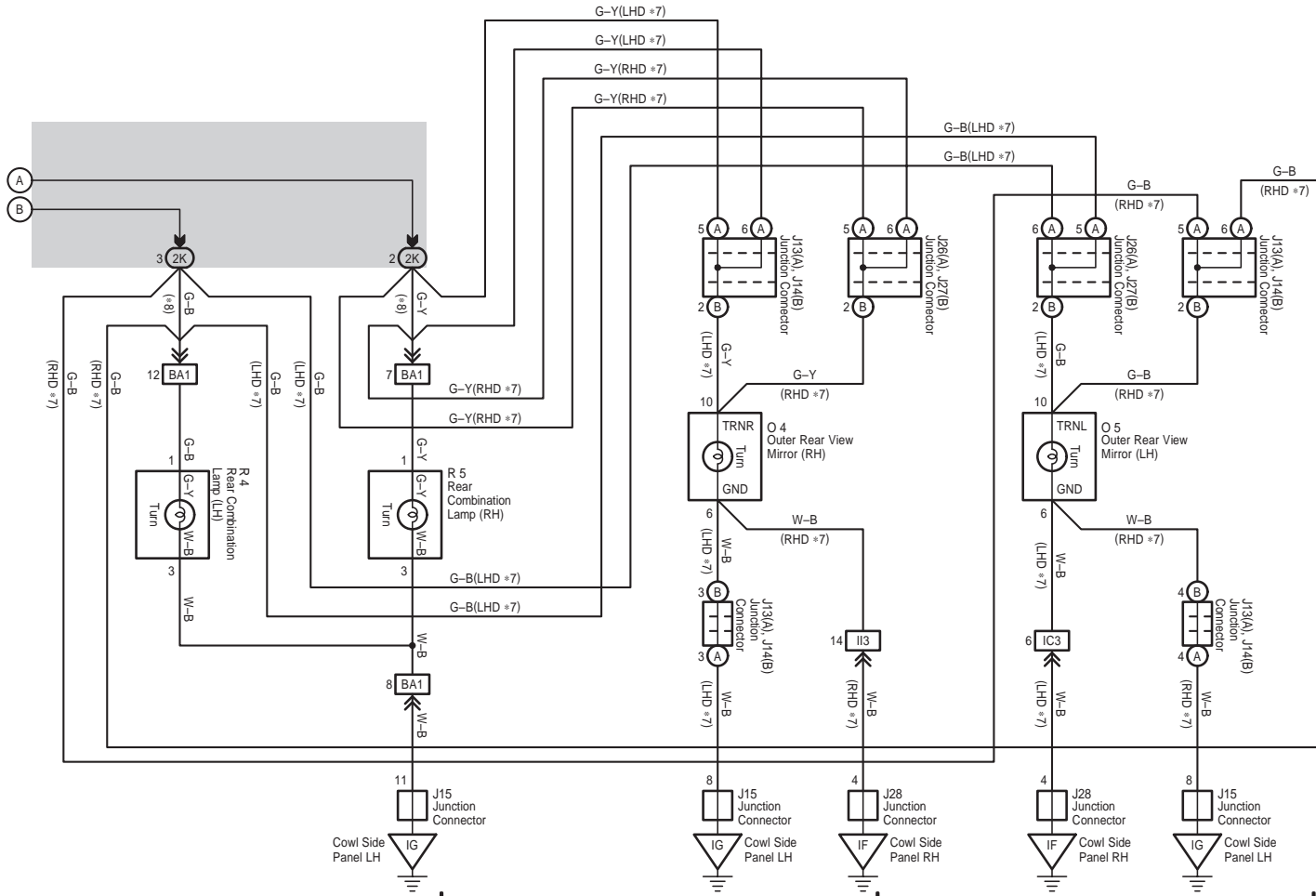

Power Source

Taillight and Illumination

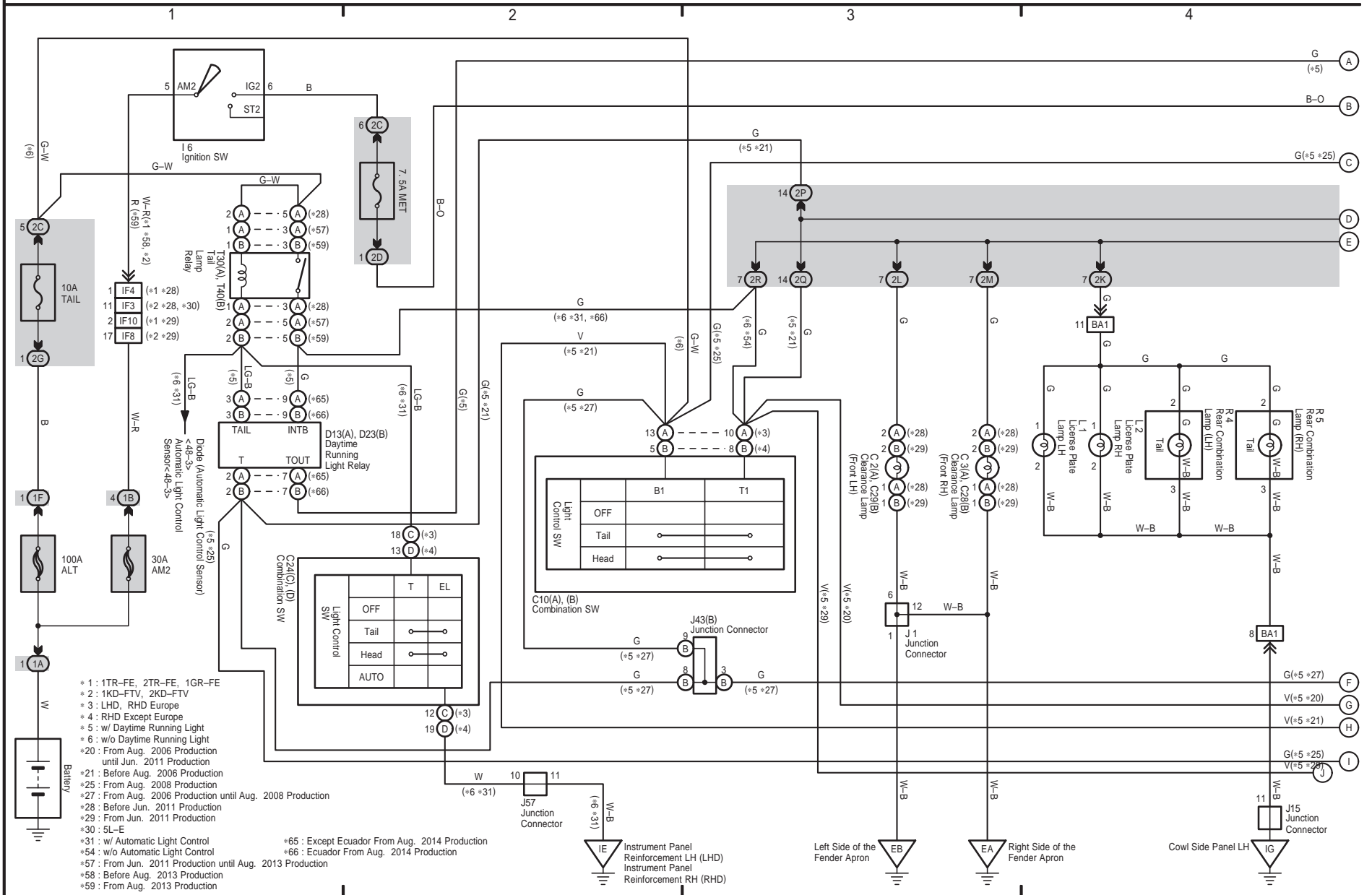

- * 1 : 1TR-FE, 2TR-FE, 1GR-FE
- * 2 : 1KD-FTV, 2KD-FTV
- * 3 : LHD, RHD Europe
- * 4 : RHD Except Europe
- * 5 : w/ Daytime Running Light
- * 6 : w/o Daytime Running Light
- * 20 : From Aug. 2006 Production until Jun. 2011 Production
- * 21 : Before Aug. 2006 Production
- * 25 : From Aug. 2008 Production
- * 27 : From Aug. 2006 Production until Aug. 2008 Production
- * 28 : Before Jun. 2011 Production
- * 29 : From Jun. 2011 Production
- * 30 : 5L-E
- * 31 : w/ Automatic Light Control
- * 54 : w/o Automatic Light Control
- * 57 : From Jun. 2011 Production until Aug. 2013 Production
- * 58 : Before Aug. 2013 Production
- * 59 : From Aug. 2013 Production
- * 65 : Except Ecuador From Aug. 2014 Production
- * 66 : Ecuador From Aug. 2014 Production

HILUX (EM1815E)

Taillight and Illumination

HILUX (EM1815E)

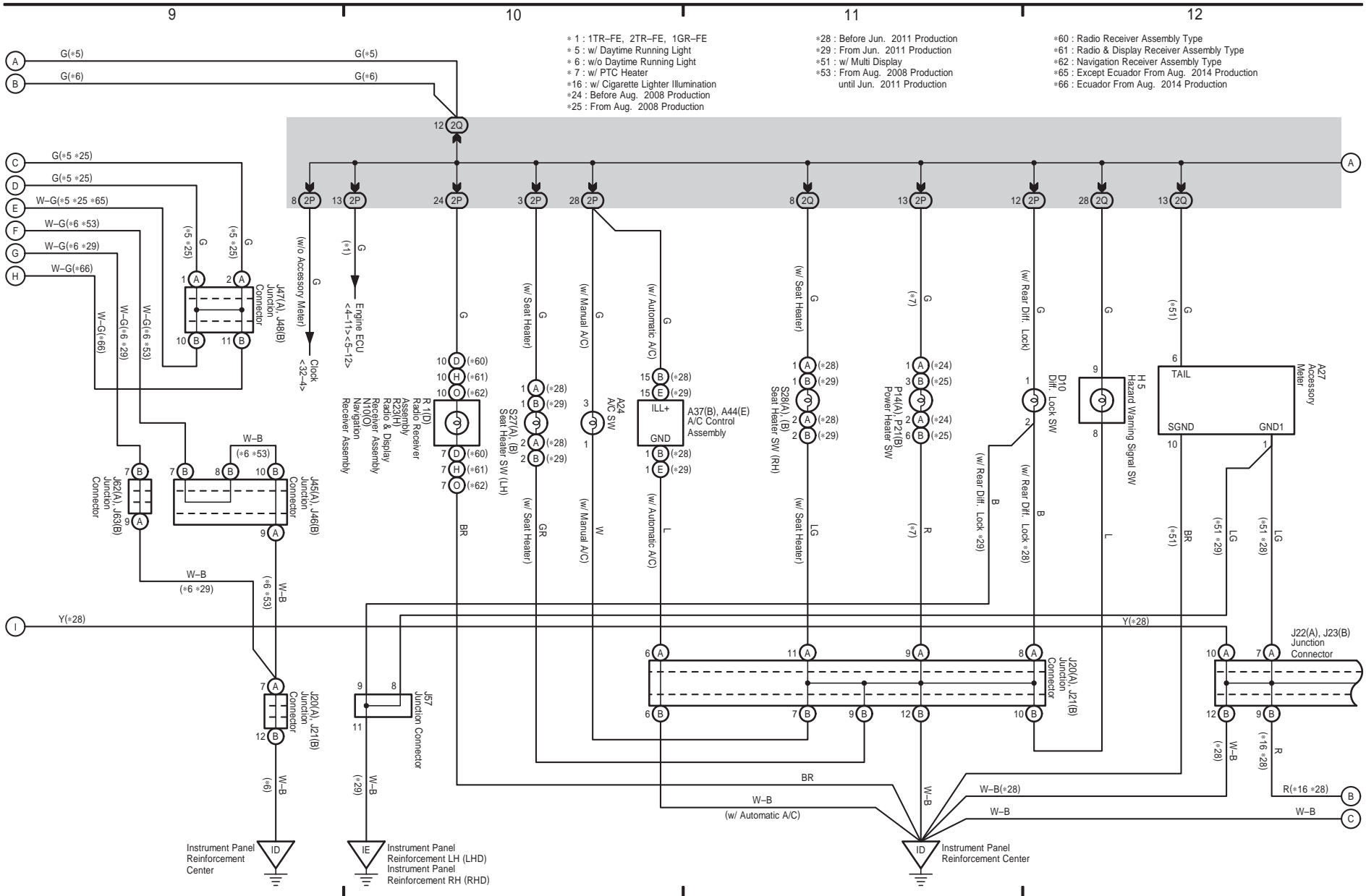

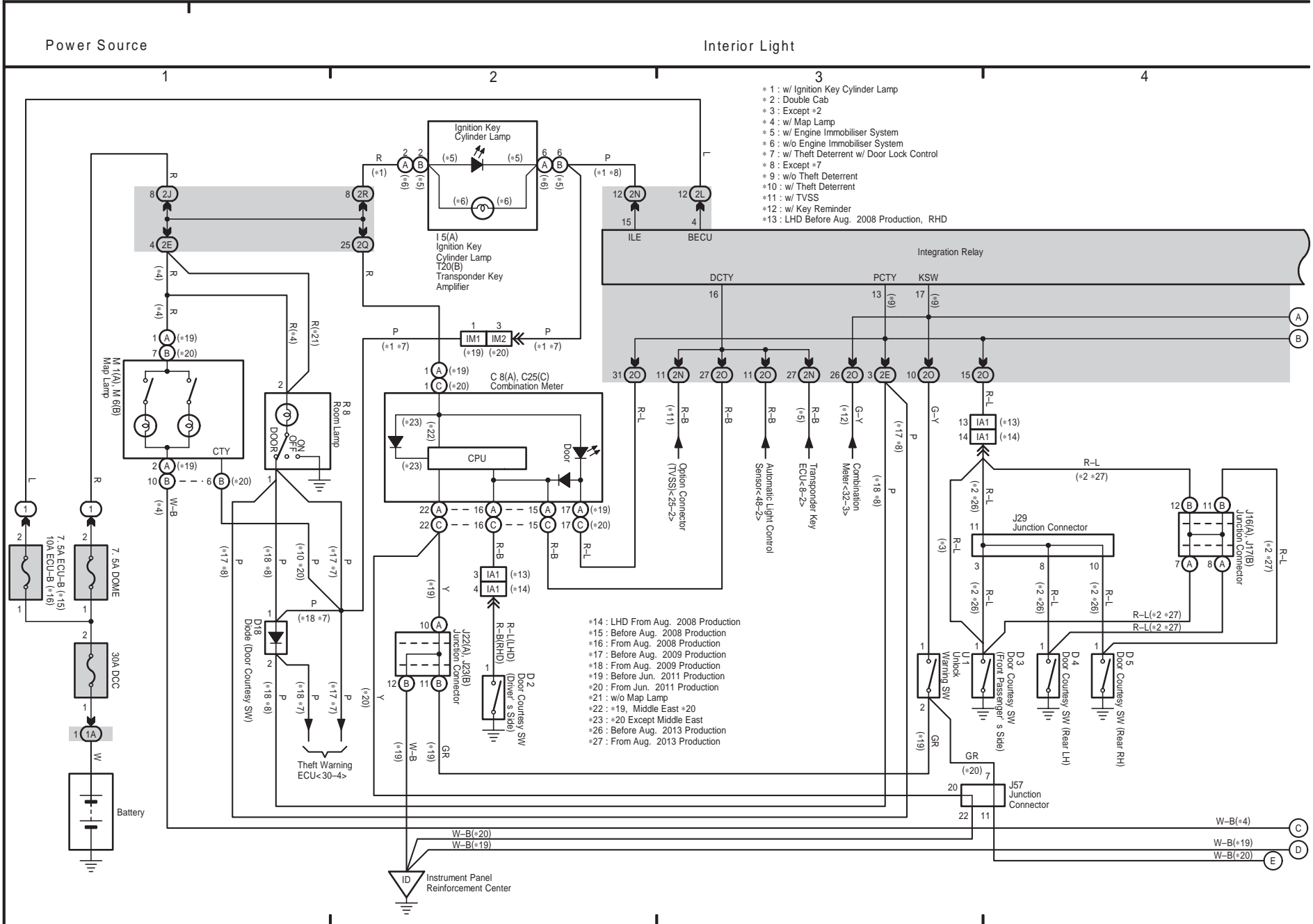

- * 1 : w/ Ignition Key Cylinder Lamp
- * 2 : Double Cab
- * 3 : Except *2
- * 4 : w/ Map Lamp
- * 5 : w/ Engine Immobiliser System
- * 6 : w/o Engine Immobiliser System
- * 7 : w/ Theft Deterrent w/ Door Lock Control
- * 8 : Except *7
- * 9 : w/o Theft Deterrent
- * 10 : w/ Theft Deterrent
- * 11 : w/ TVSS
- * 12 : w/ Key Reminder
- * 13 : LHD Before Aug. 2008 Production, RHD

- * 14 : LHD From Aug. 2008 Production
- * 15 : Before Aug. 2008 Production
- * 16 : From Aug. 2008 Production
- * 17 : Before Aug. 2009 Production
- * 18 : From Aug. 2009 Production
- * 19 : Before Jun. 2011 Production
- * 20 : From Jun. 2011 Production
- * 21 : w/o Map Lamp
- * 22 : *19, Middle East *20
- * 23 : *20 Except Middle East
- * 26 : Before Aug. 2013 Production
- * 27 : From Aug. 2013 Production

Interior Light

5 | | | 6 | | | 7 | | | 8

- * 4 : w/ Map Lamp
- * 5 : w/ Engine Immobiliser System
- *10 : w/ Theft Deterrent
- *11 : w/ TVSS
- *19 : Before Jun. 2011 Production
- *20 : From Jun. 2011 Production
- *24 : RHD *10 South Africa *25
- *25 : From Aug. 2012 Production

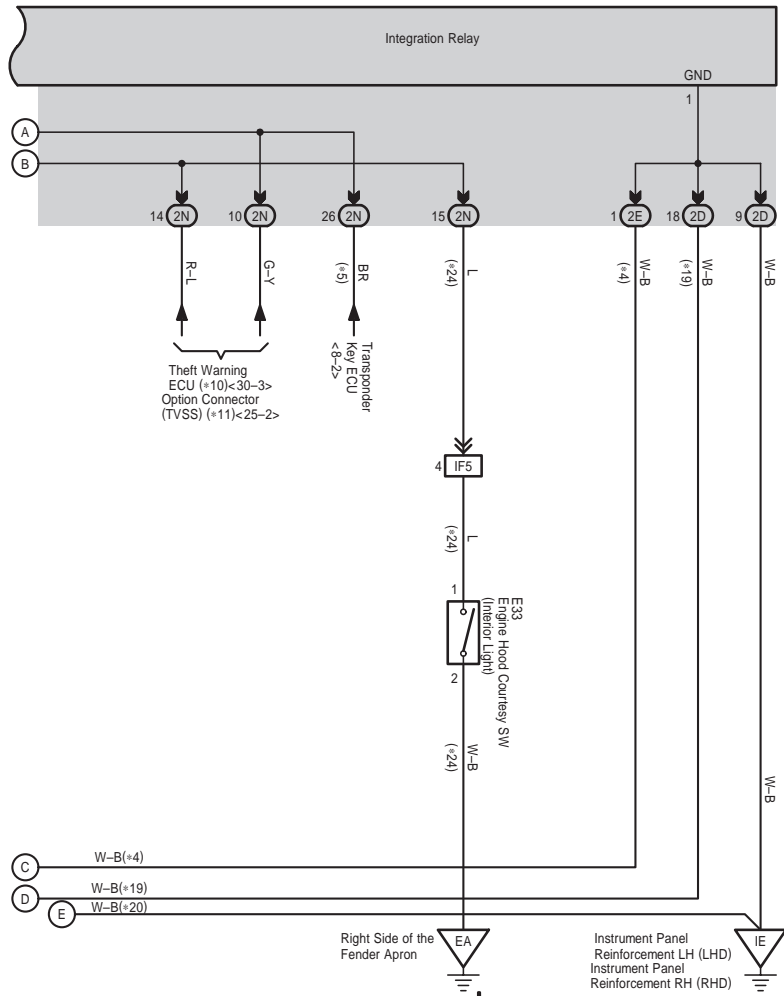

HILUX (EM1815E)

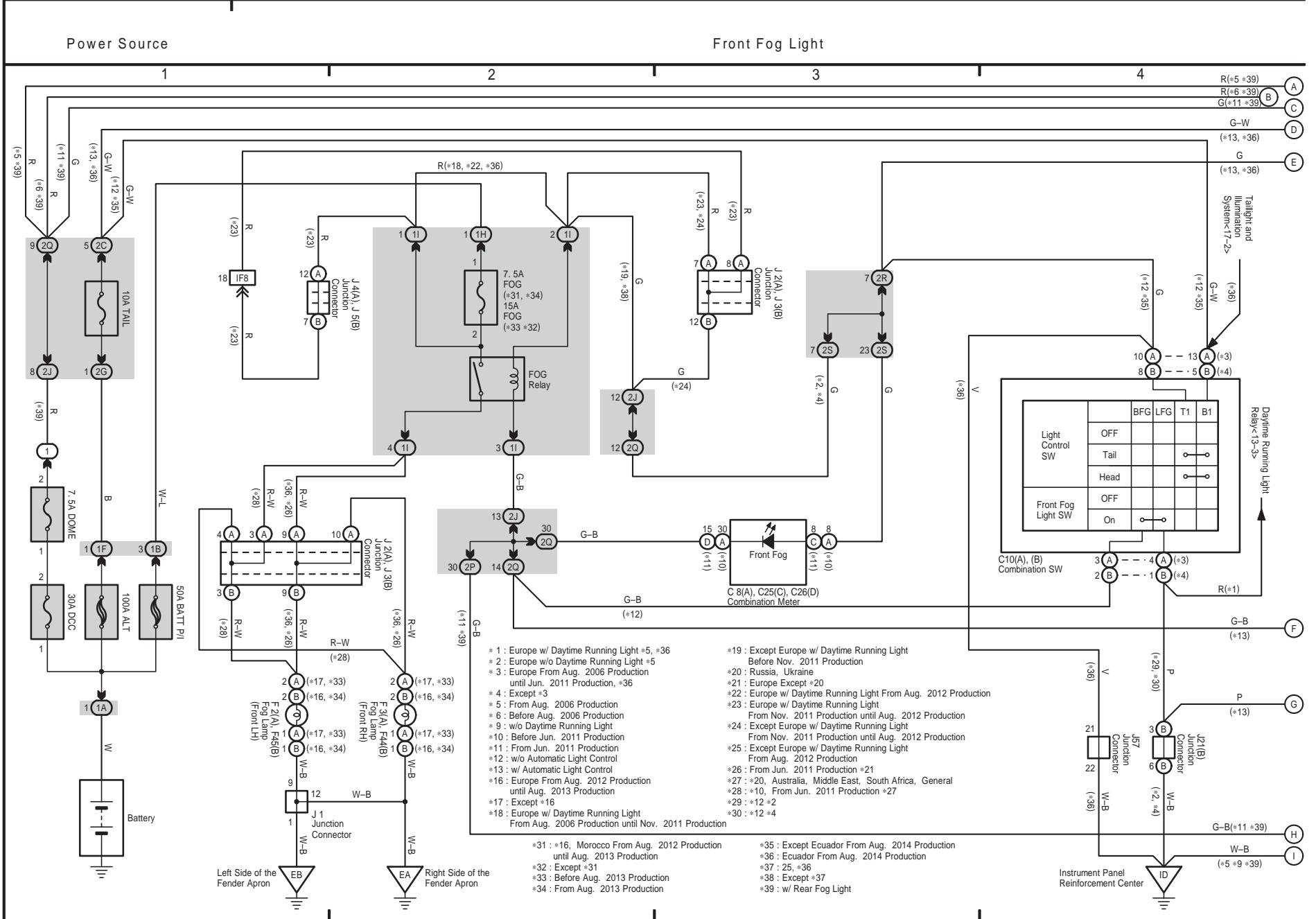

- * 1 : Europe w/ Daytime Running Light *5, *36
- * 2 : Europe w/o Daytime Running Light *5
- * 3 : Europe From Aug. 2006 Production until Jun. 2011 Production, *36
- * 4 : Except *3
- * 5 : From Aug. 2006 Production
- * 6 : Before Aug. 2006 Production
- * 9 : w/o Daytime Running Light
- * 10 : Before Jun. 2011 Production
- * 11 : From Jun. 2011 Production
- * 12 : w/o Automatic Light Control
- * 13 : w/ Automatic Light Control
- * 16 : Europe From Aug. 2012 Production until Aug. 2013 Production
- * 17 : Except *16
- * 18 : Europe w/ Daytime Running Light From Aug. 2006 Production until Nov. 2011 Production
- * 19 : Except Europe w/ Daytime Running Light Before Nov. 2011 Production
- * 20 : Russia, Ukraine
- * 21 : Europe Except *20
- * 22 : Europe w/ Daytime Running Light From Aug. 2012 Production
- * 23 : Europe w/ Daytime Running Light From Nov. 2011 Production until Aug. 2012 Production
- * 24 : Except Europe w/ Daytime Running Light From Nov. 2011 Production until Aug. 2012 Production
- * 25 : Except Europe w/ Daytime Running Light From Aug. 2012 Production
- * 26 : From Jun. 2011 Production *21
- * 27 : *20, Australia, Middle East, South Africa, General
- * 28 : *10, From Jun. 2011 Production *27
- * 29 : *12 *2
- * 30 : *12 *4
- * 31 : *16, Morocco From Aug. 2012 Production until Aug. 2013 Production
- * 32 : Except *31
- * 33 : Before Aug. 2013 Production
- * 34 : From Aug. 2013 Production
- * 35 : Except Ecuador From Aug. 2014 Production
- * 36 : Ecuador From Aug. 2014 Production
- * 37 : *25, *36
- * 38 : Except *37
- * 39 : w/ Rear Fog Light

Rear Fog Light

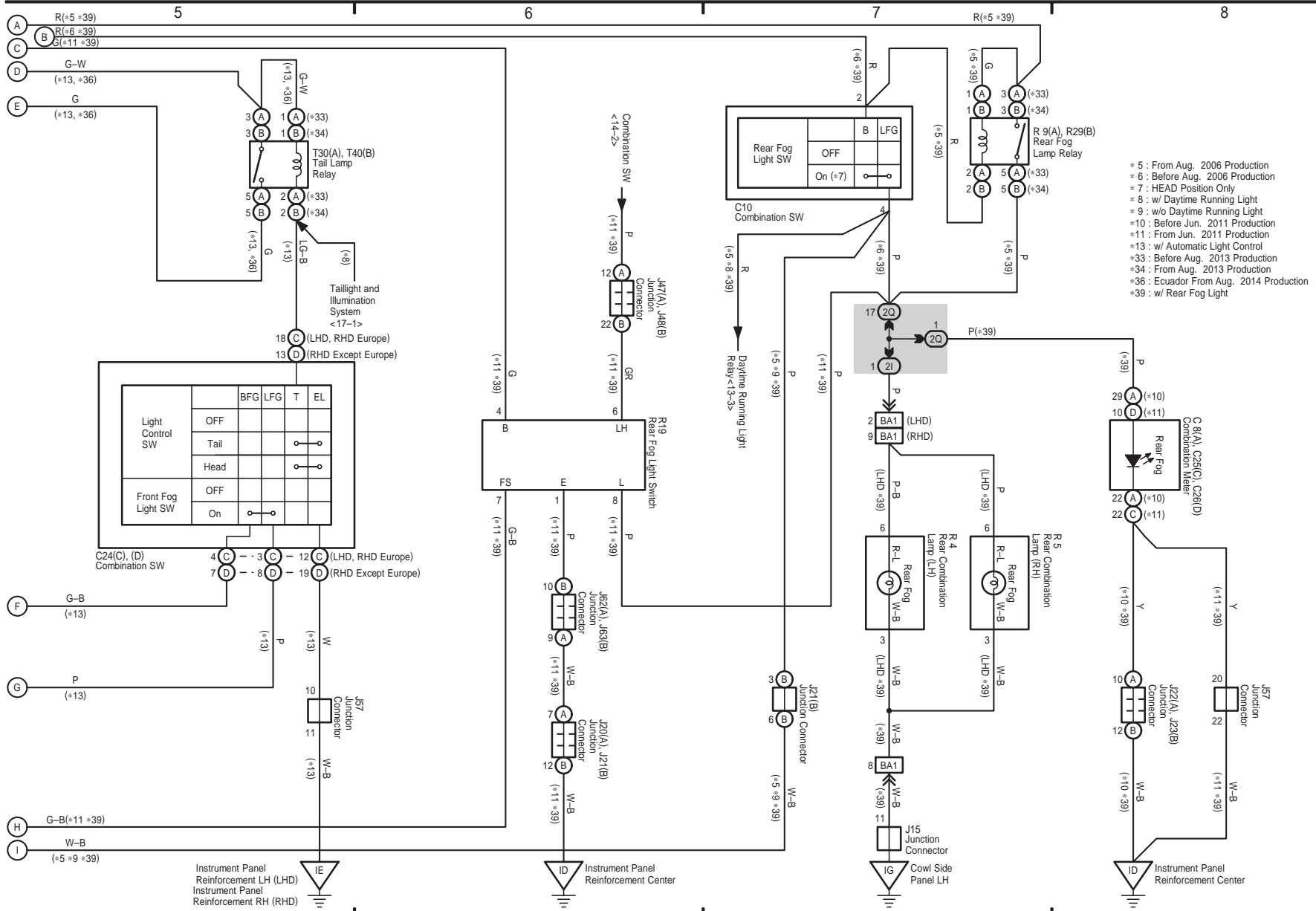

HILUX (EM1815E)

HILUX (EM1815E)

M OVERALL ELECTRICAL WIRING DIAGRAM

cardiagn.com

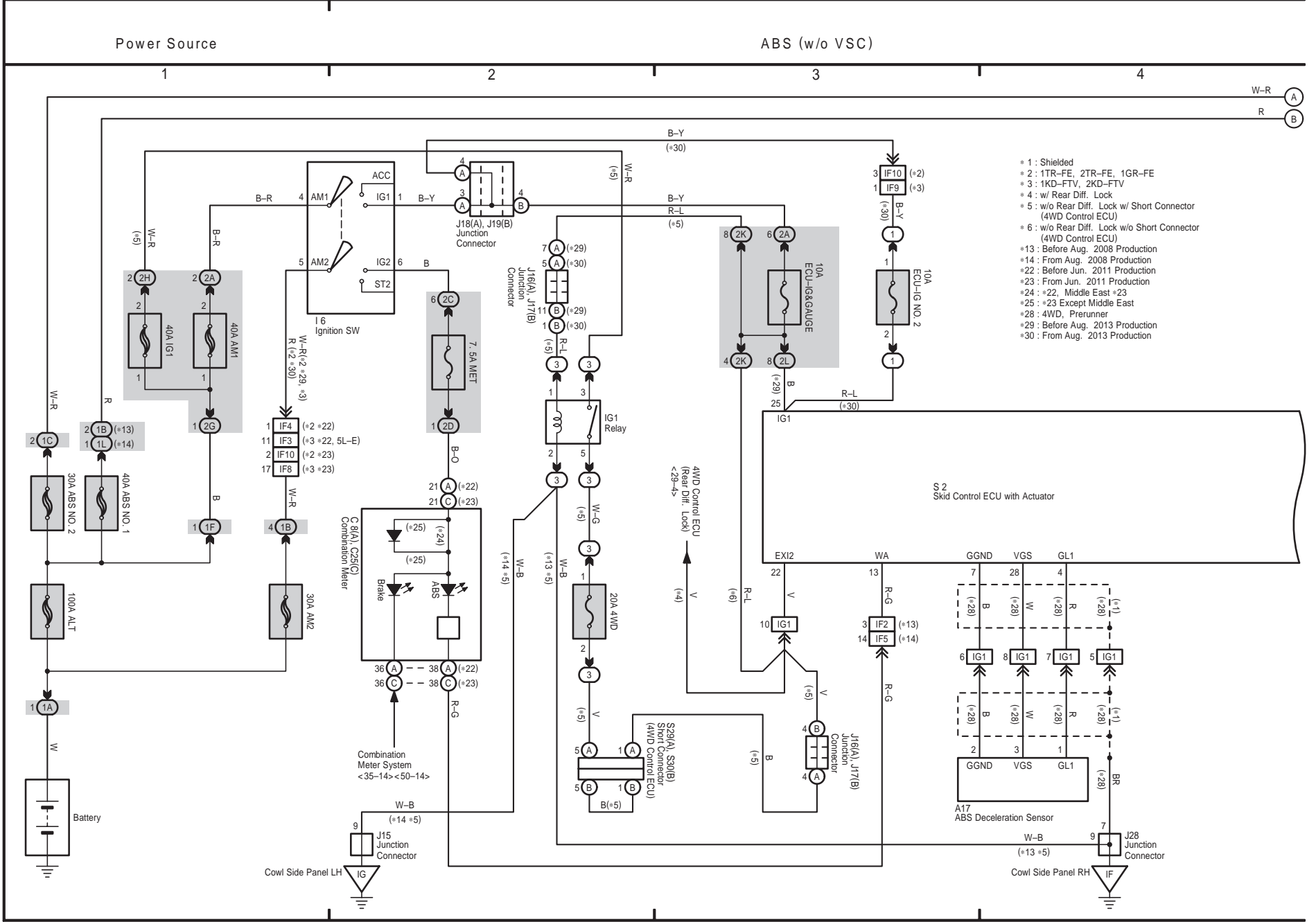

- * 1 : Shielded
- * 2 : 1TR-FE, 2TR-FE, 1GR-FE
- * 3 : 1KD-FTV, 2KD-FTV
- * 4 : w/ Rear Diff. Lock
- * 5 : w/o Rear Diff. Lock w/ Short Connector (4WD Control ECU)
- * 6 : w/o Rear Diff. Lock w/o Short Connector (4WD Control ECU)
- * 13 : Before Aug. 2008 Production
- * 14 : From Aug. 2008 Production
- * 22 : Before Jun. 2011 Production
- * 23 : From Jun. 2011 Production
- * 24 : +22, Middle East +23
- * 25 : +23 Except Middle East
- * 28 : 4WD, Pre-runner
- * 29 : Before Aug. 2013 Production
- * 30 : From Aug. 2013 Production

ABS (w/o VSC)

HILUX (EM1815E)

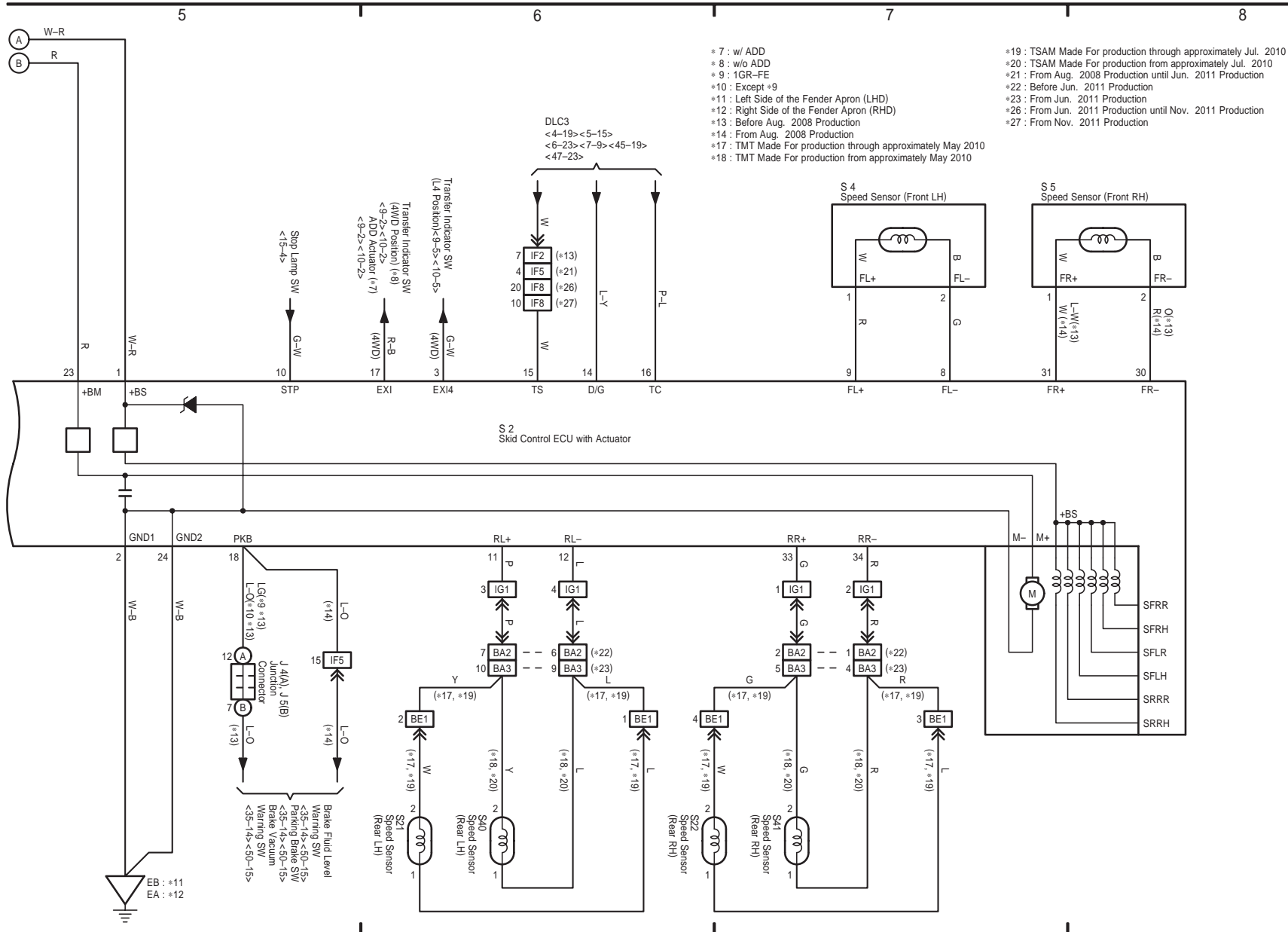

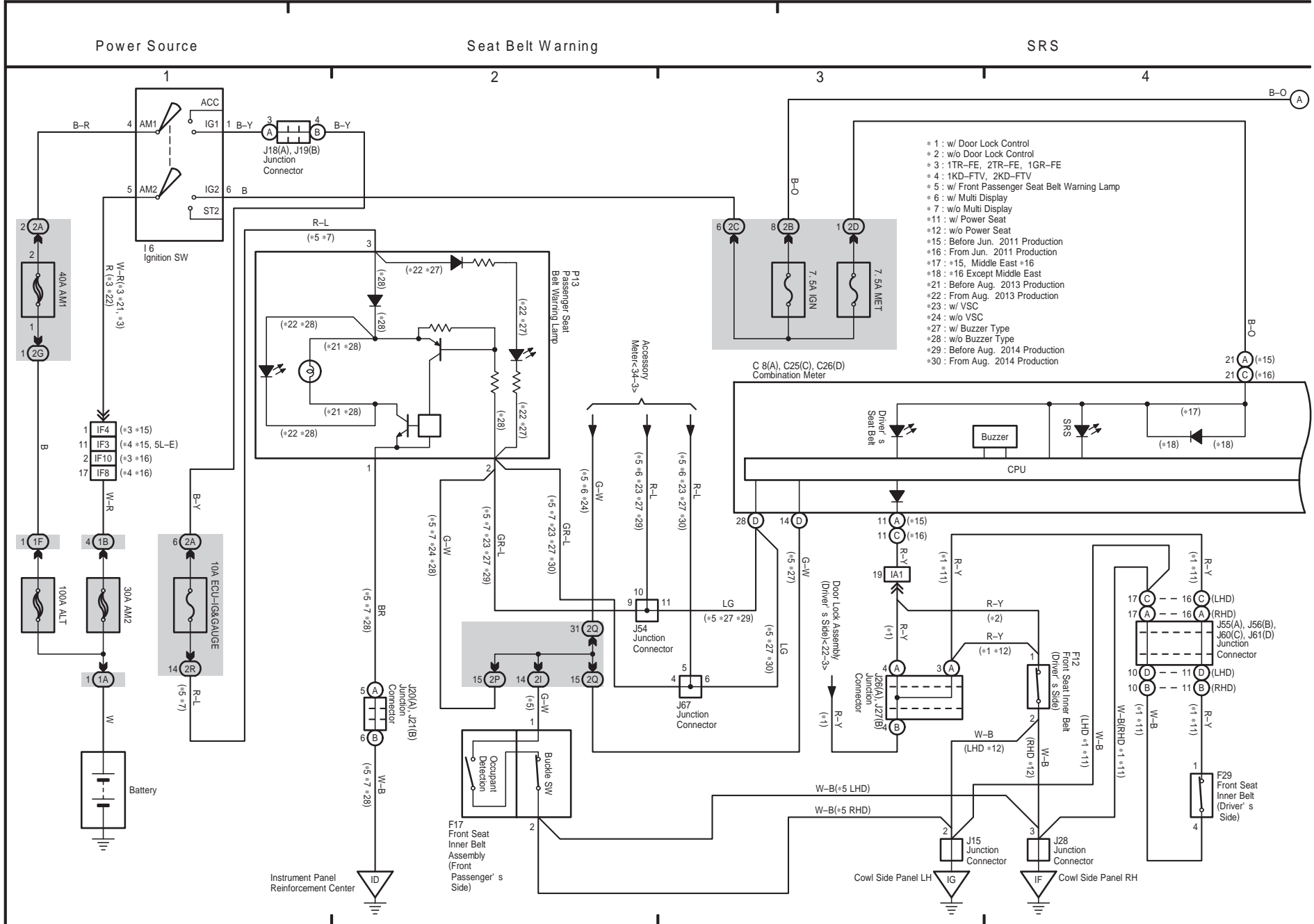

SRS

- * 3 : 1TR-FE, 2TR-FE, 1GR-FE
- * 8 : w/ Front Passenger Airbag
- * 9 : w/ Pretensioner
- * 10 : w/ Side Airbag
- * 15 : Before Jun. 2011 Production
- * 16 : From Jun. 2011 Production
- * 19 : Before Aug. 2012 Production
- * 20 : From Aug. 2012 Production
- * 29 : Before Aug. 2014 Production
- * 30 : From Aug. 2014 Production

HILUX (EM1815E)

cardiagn.com

M

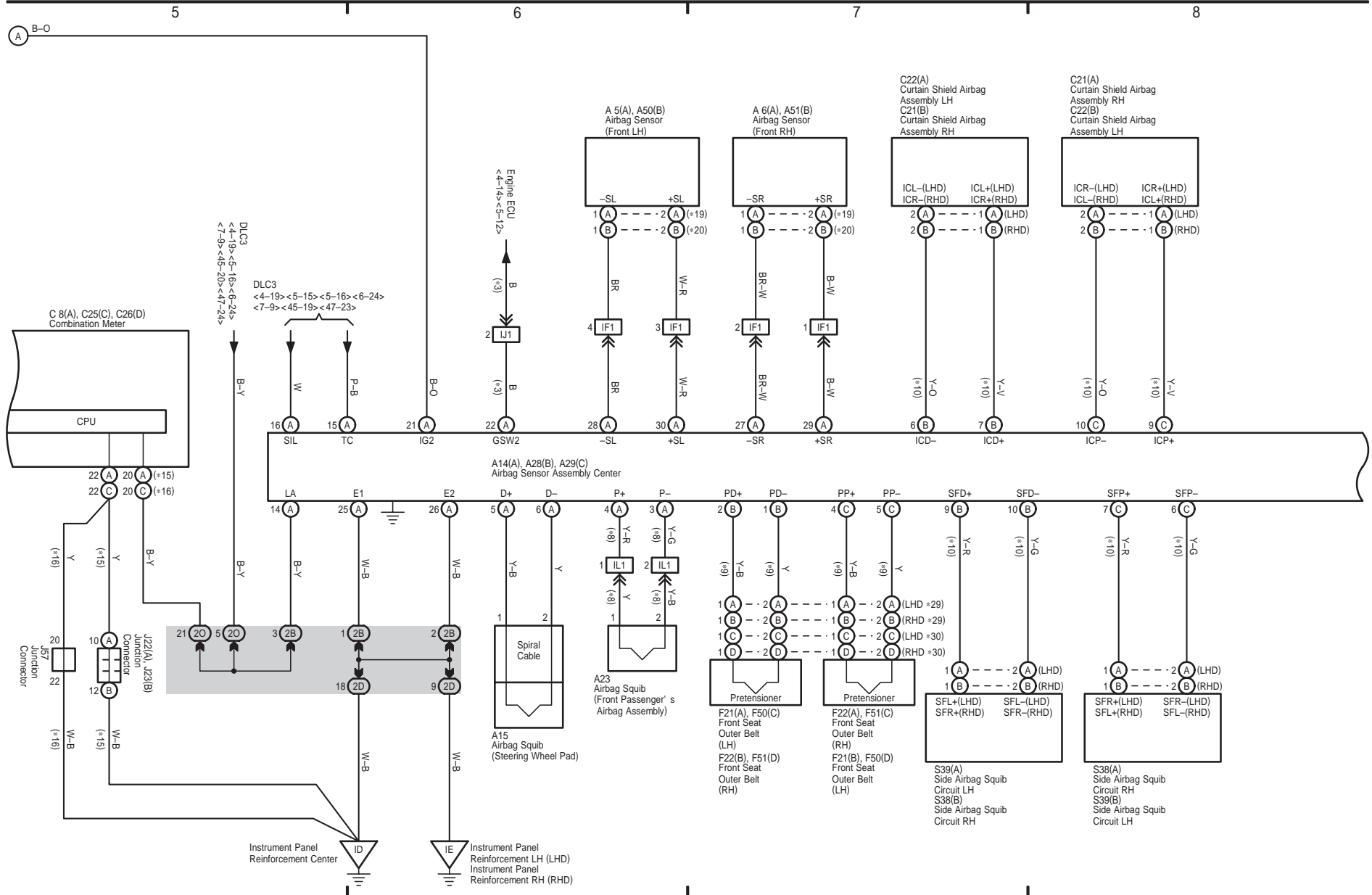

SRS

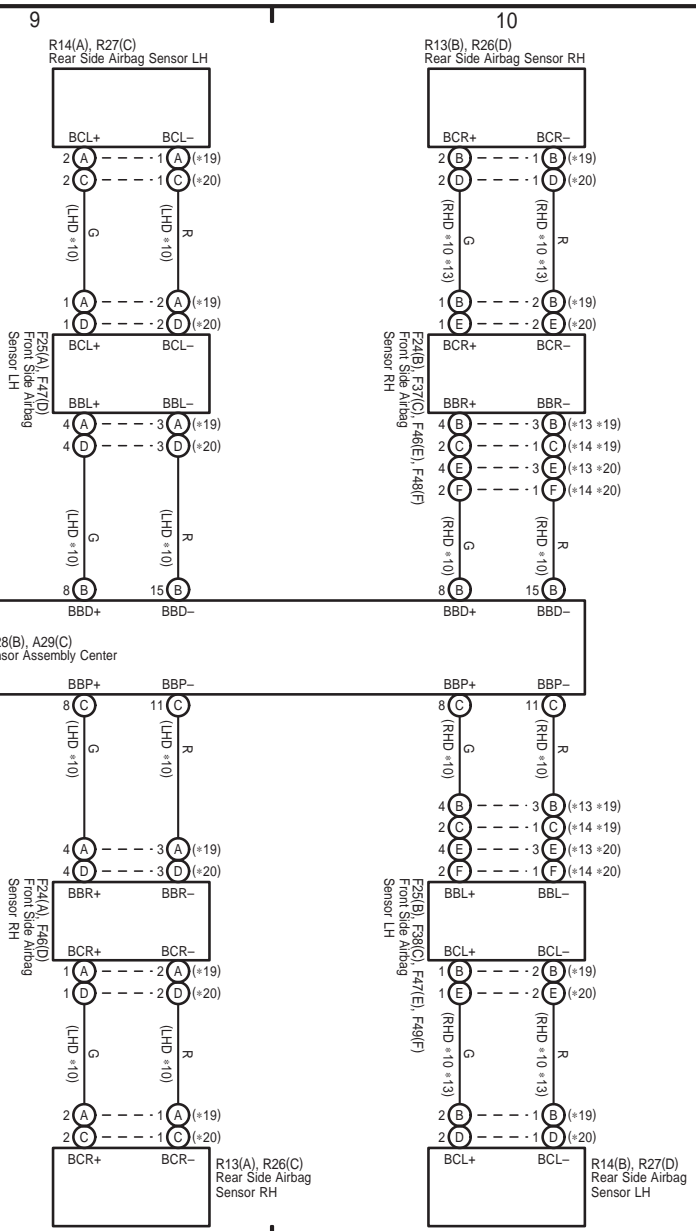

*10 : w/ Side Airbag
 *13 : w/ Rear Side Airbag Sensor
 *14 : w/o Rear Side Airbag Sensor
 *19 : Before Aug. 2012 Production
 *20 : From Aug. 2012 Production

HILUX (EM1815E)

Power Source

Door Lock Control

HILUX (EM1815E)

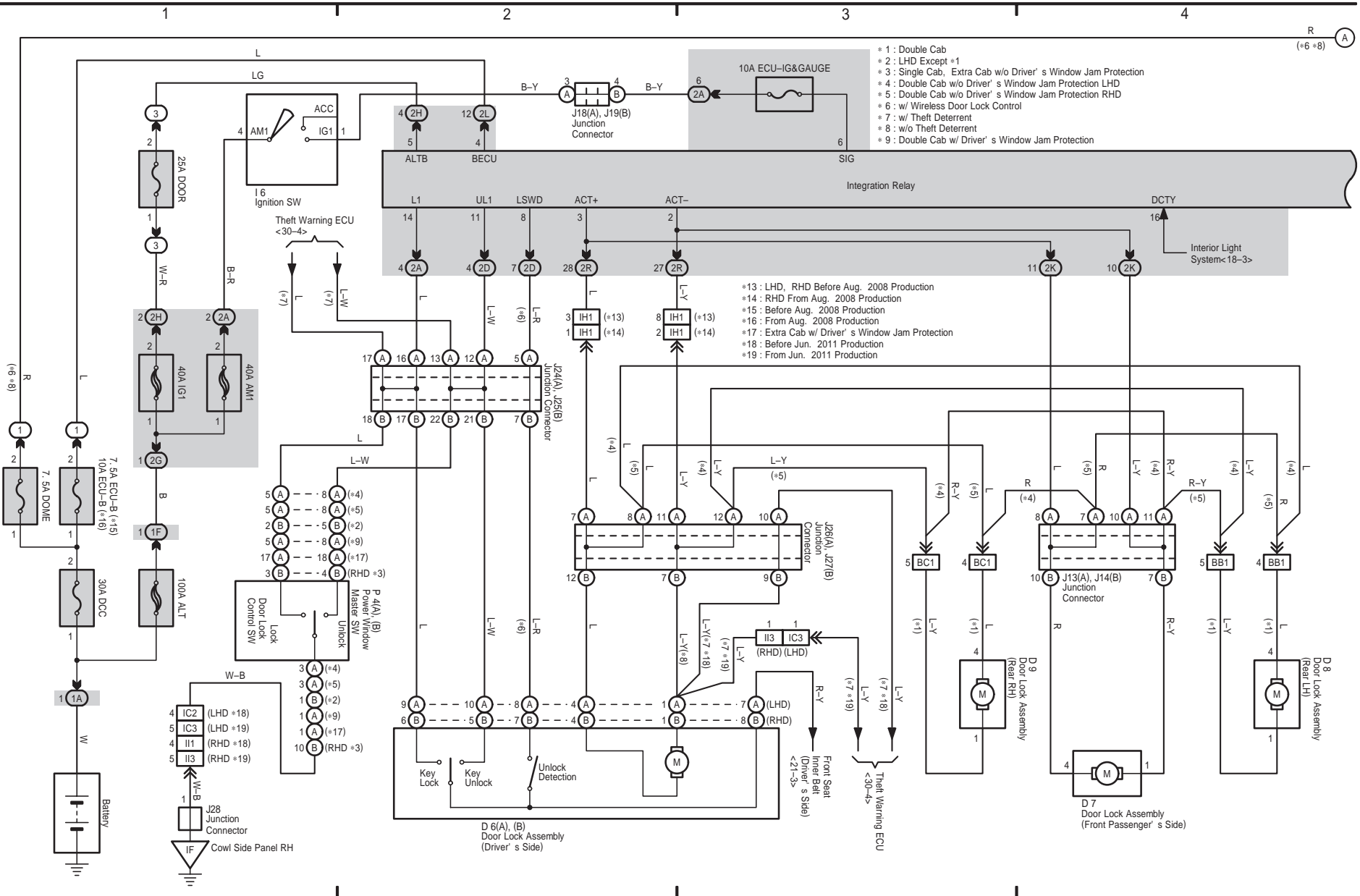

22 HILUX (Cont' d)

Door Lock Control

Wireless Door Lock Control (w/o Theft Deterrent System)

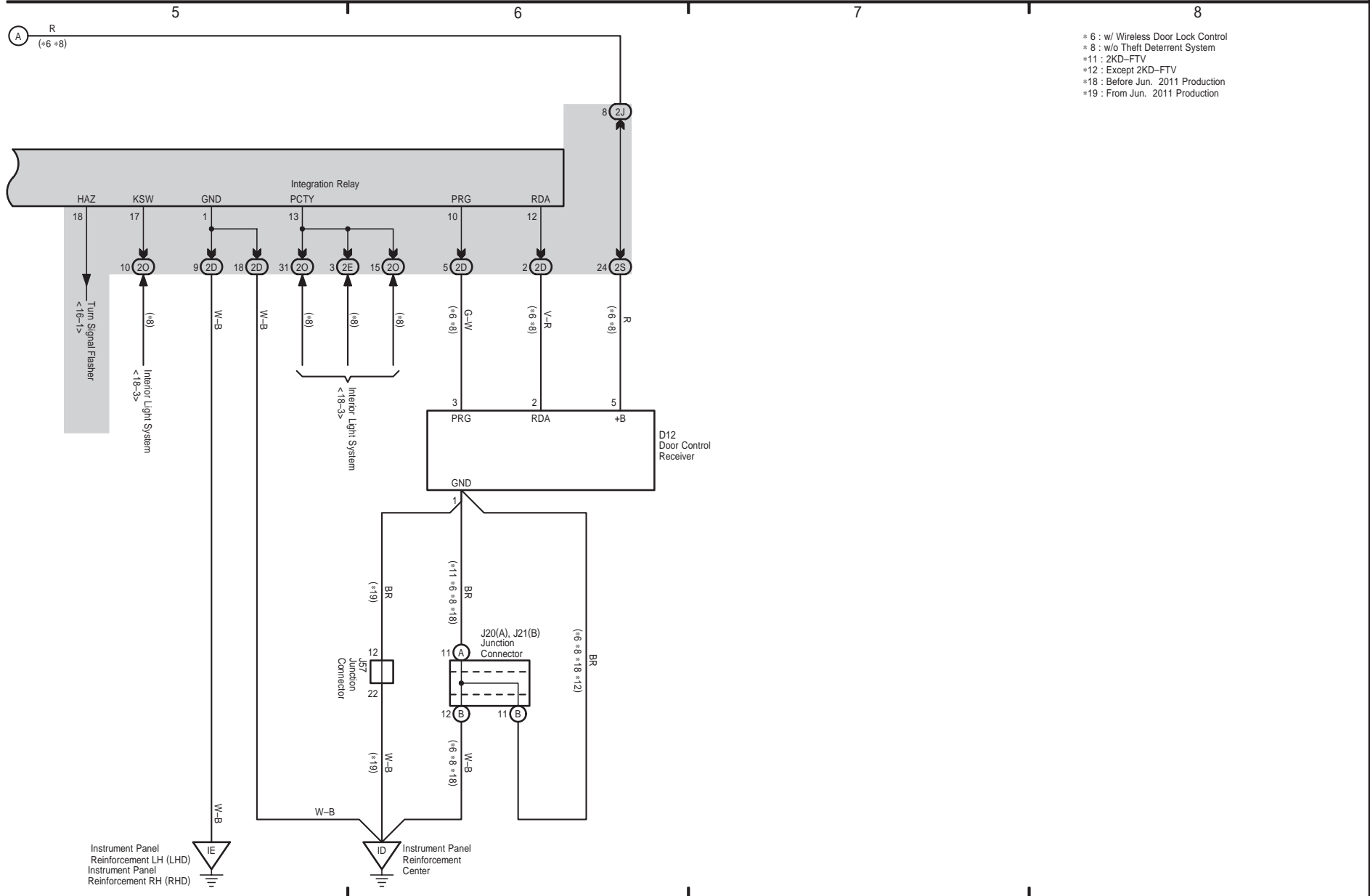

HILUX (EM1815E)

Power Window

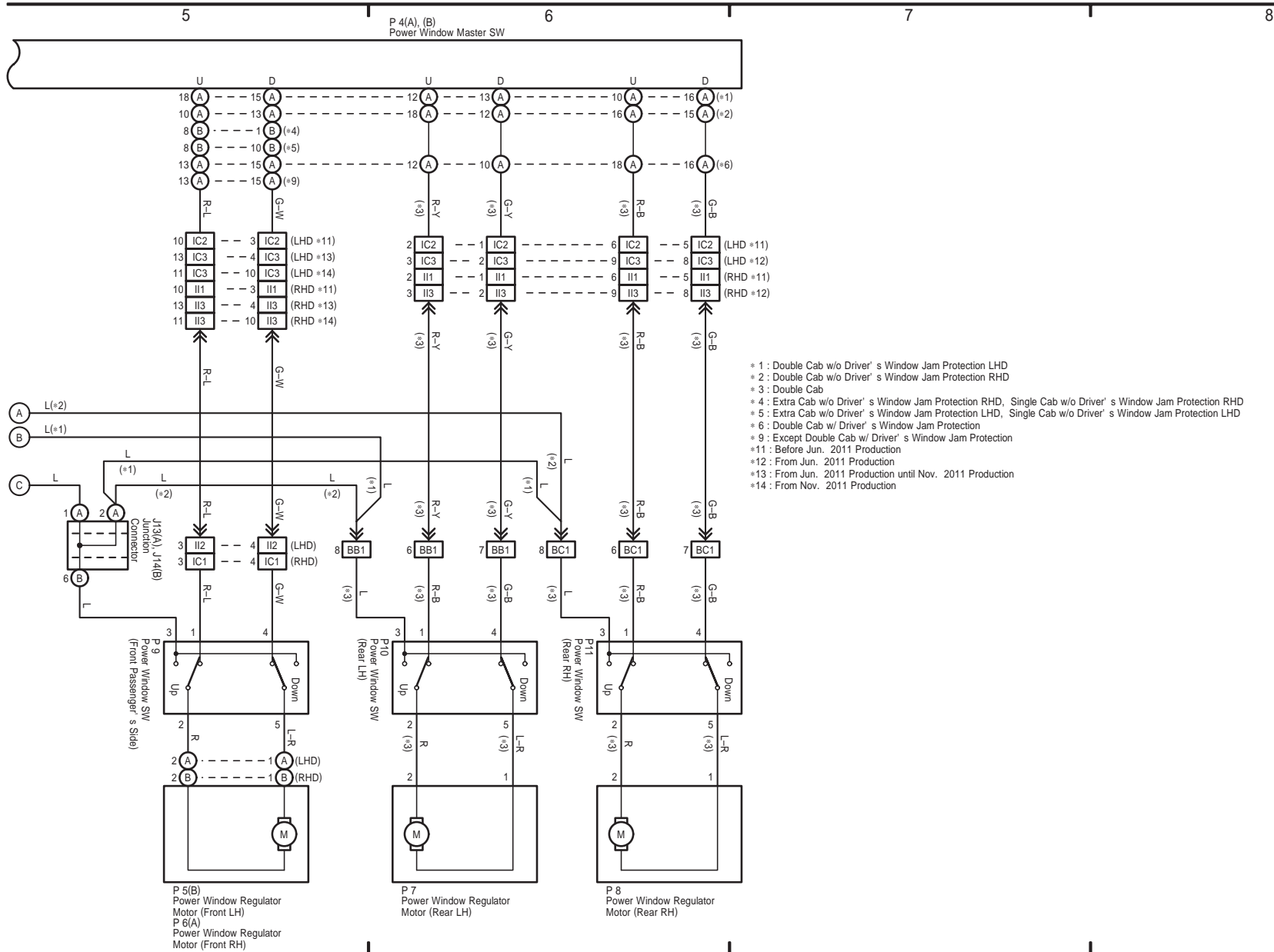

Power Source

Front Wiper and Washer

1 2 3 4

- * 1 : w/ INT Time SW
- * 2 : From Aug. 2008 Production
- * 3 : Before Aug. 2008 Production
- * 4 : LHD, RHD Europe
- * 5 : RHD Except Europe

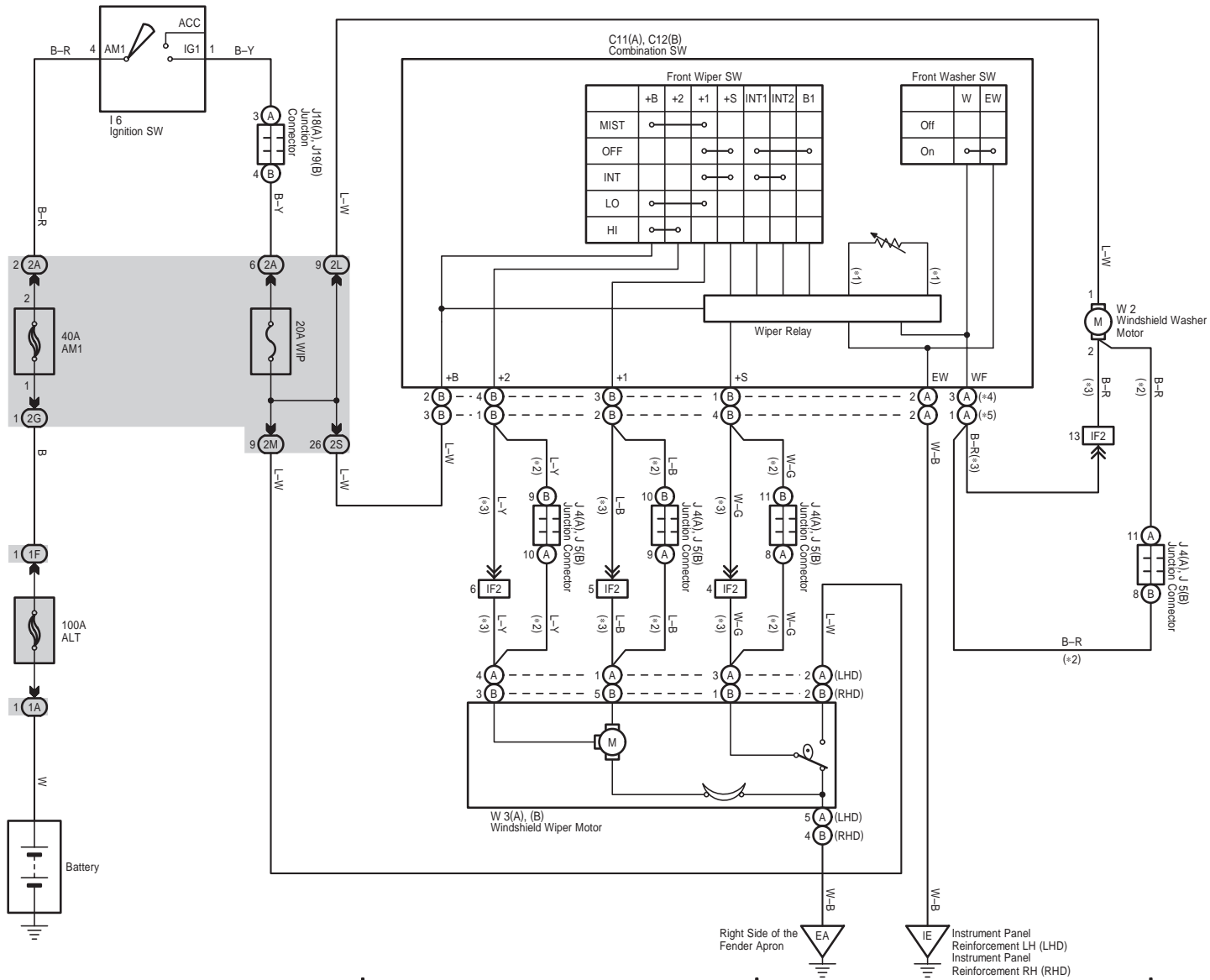

HILUX (EM1815E)

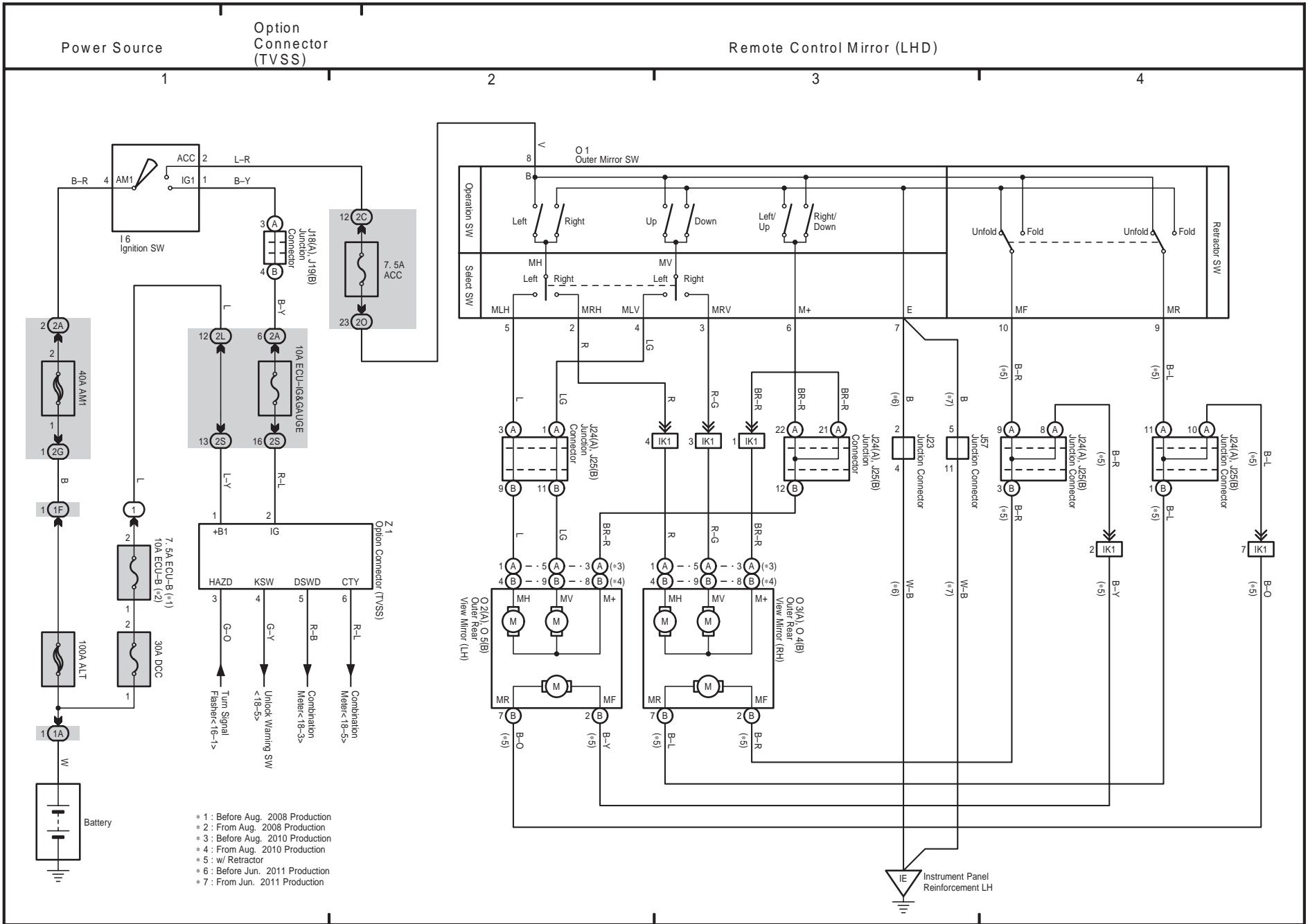

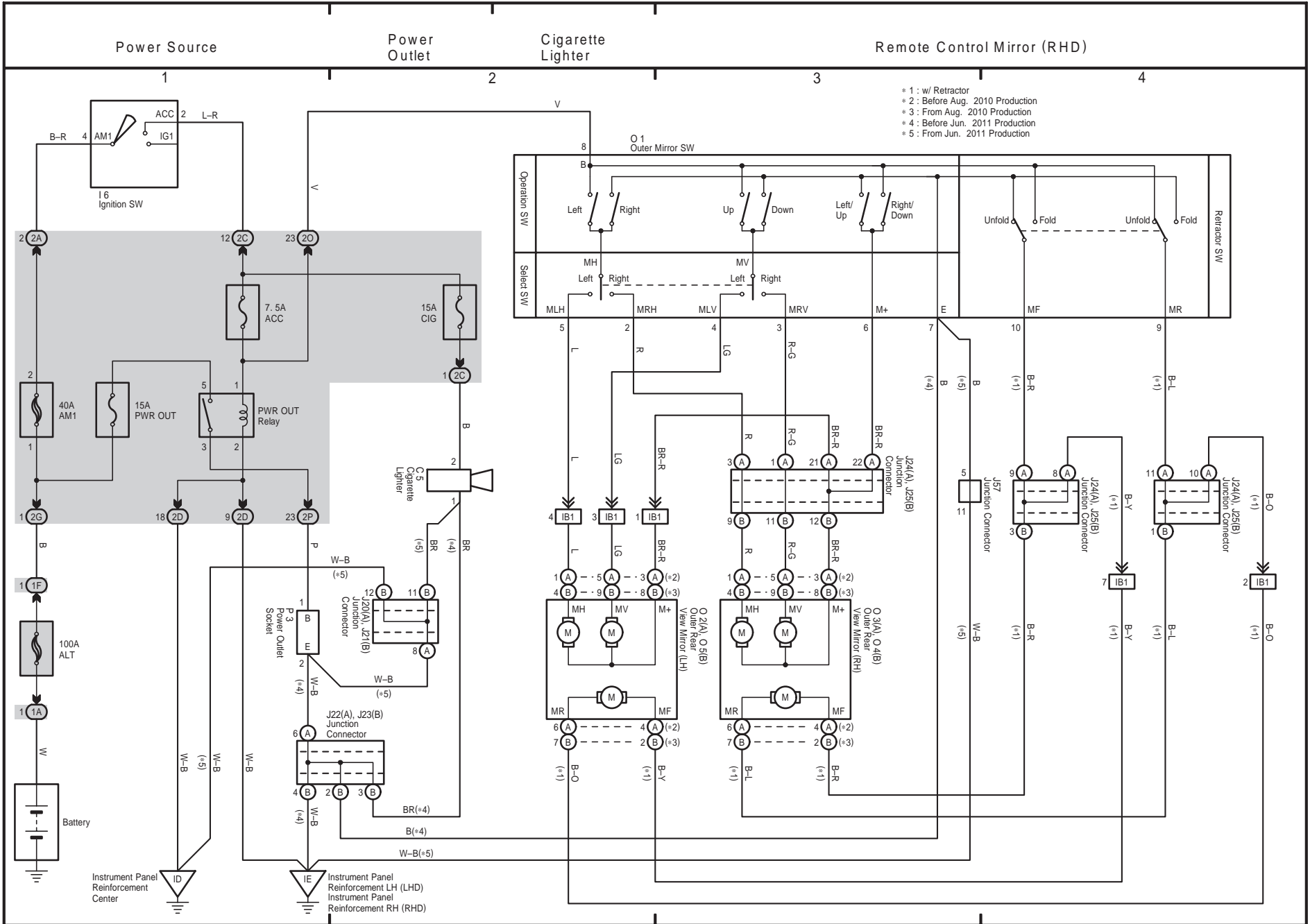

HILUX (EM1815E)

M OVERALL ELECTRICAL WIRING DIAGRAM

cardiagn.com

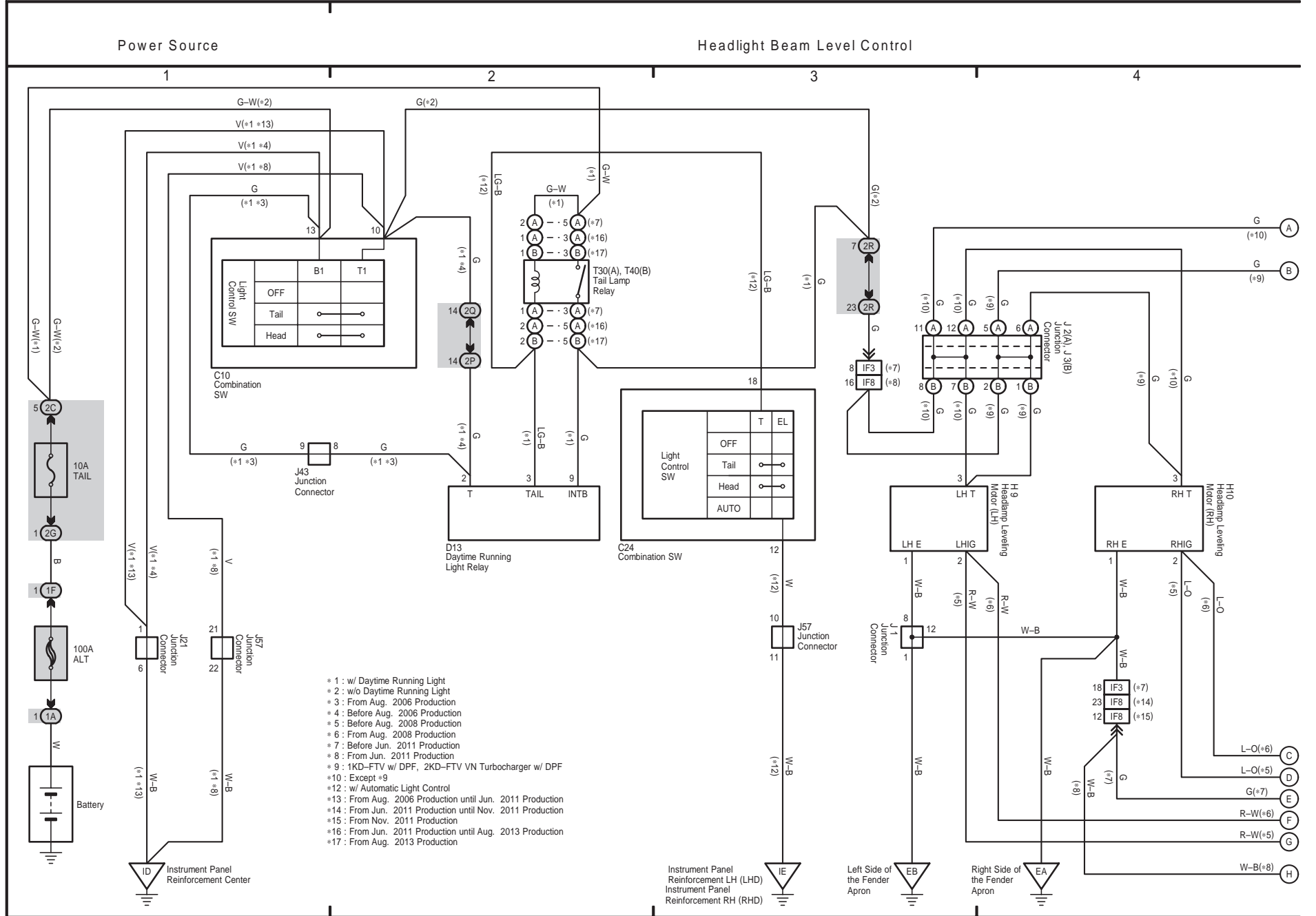

Headlight Beam Level Control

5 | | | | | 6 | | | | | 7 | | | | | 8

- * 5 : Before Aug. 2008 Production
- * 6 : From Aug. 2008 Production
- * 7 : Before Jun. 2011 Production
- * 8 : From Jun. 2011 Production
- * 9 : 1KD-FTV w/ DPF, 2KD-FTV VN Turbocharger w/ DPF
- * 10 : Except *9
- * 11 : From Jun. 2008 Production until Jun. 2011 Production

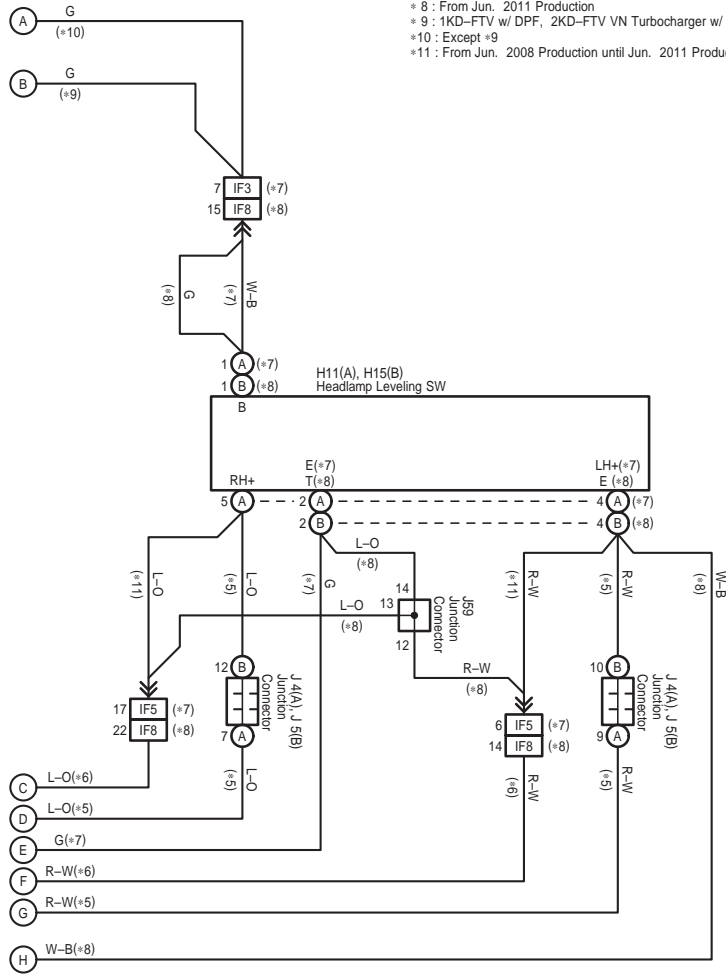

HILUX (EM1815E)

Power Source

Seat Heater

HILUX (EM1815E)

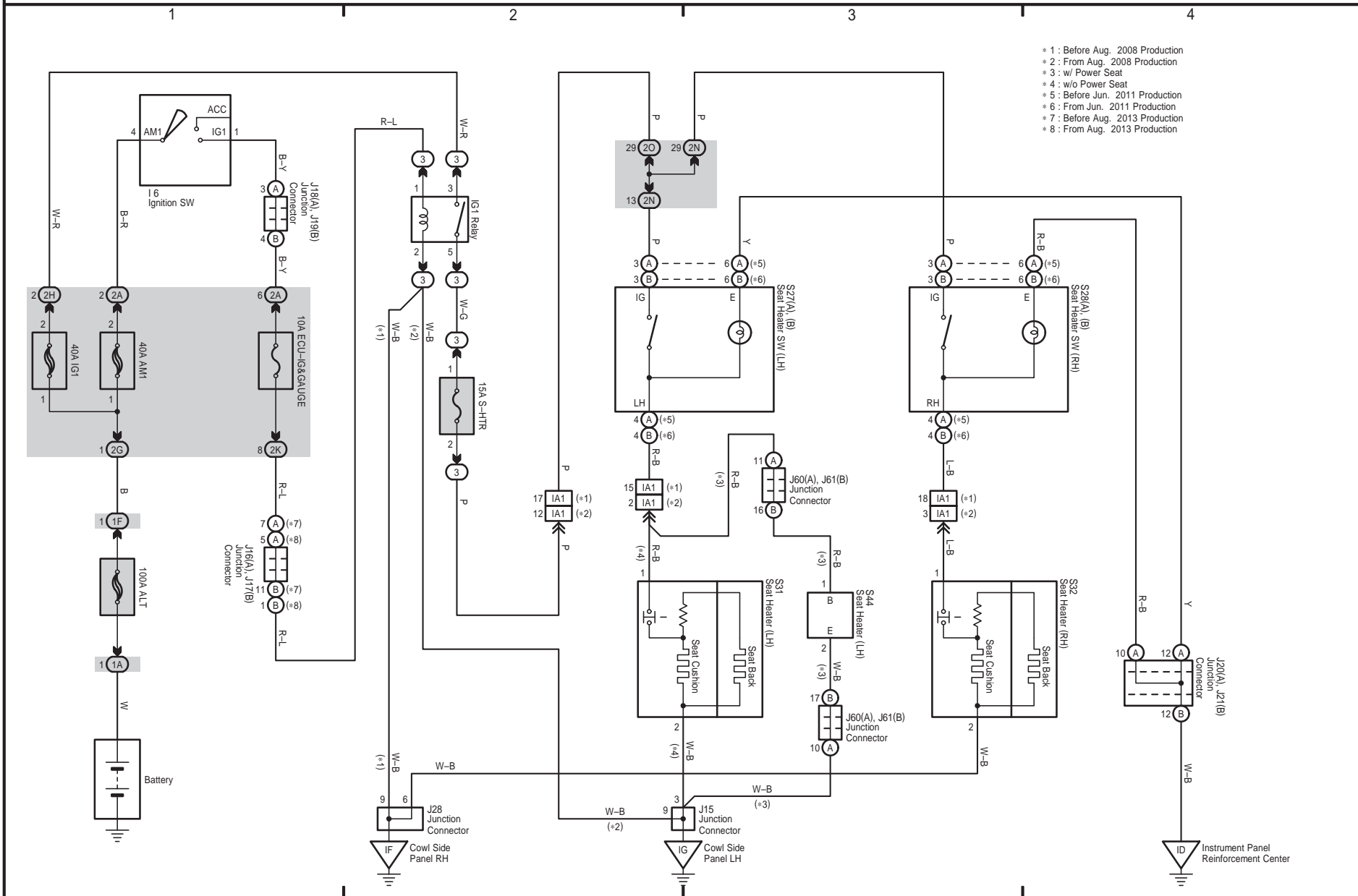

- * 1 : Before Aug. 2008 Production
- * 2 : From Aug. 2008 Production
- * 3 : w/ Power Seat
- * 4 : w/o Power Seat
- * 5 : Before Jun. 2011 Production
- * 6 : From Jun. 2011 Production
- * 7 : Before Aug. 2013 Production
- * 8 : From Aug. 2013 Production

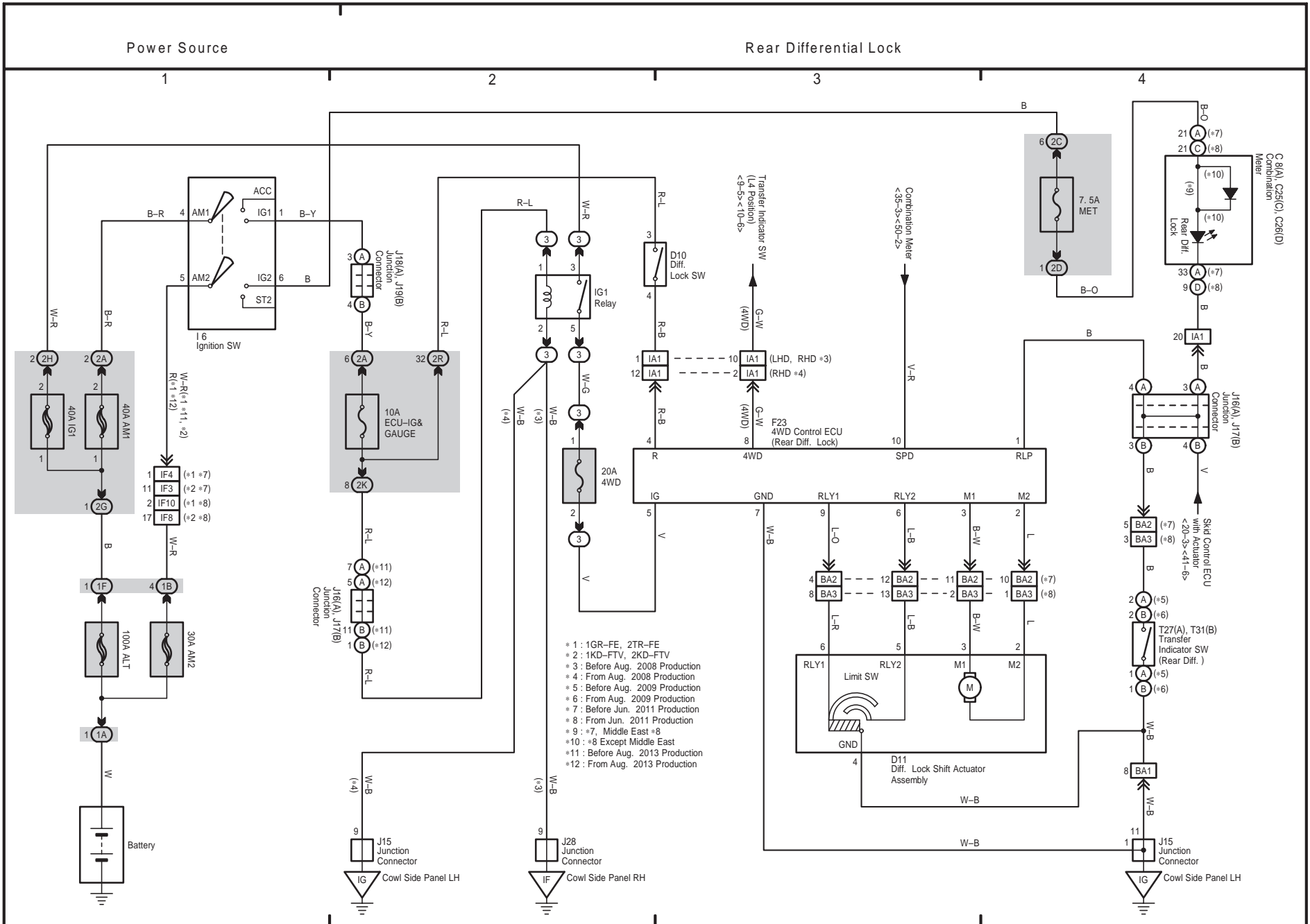

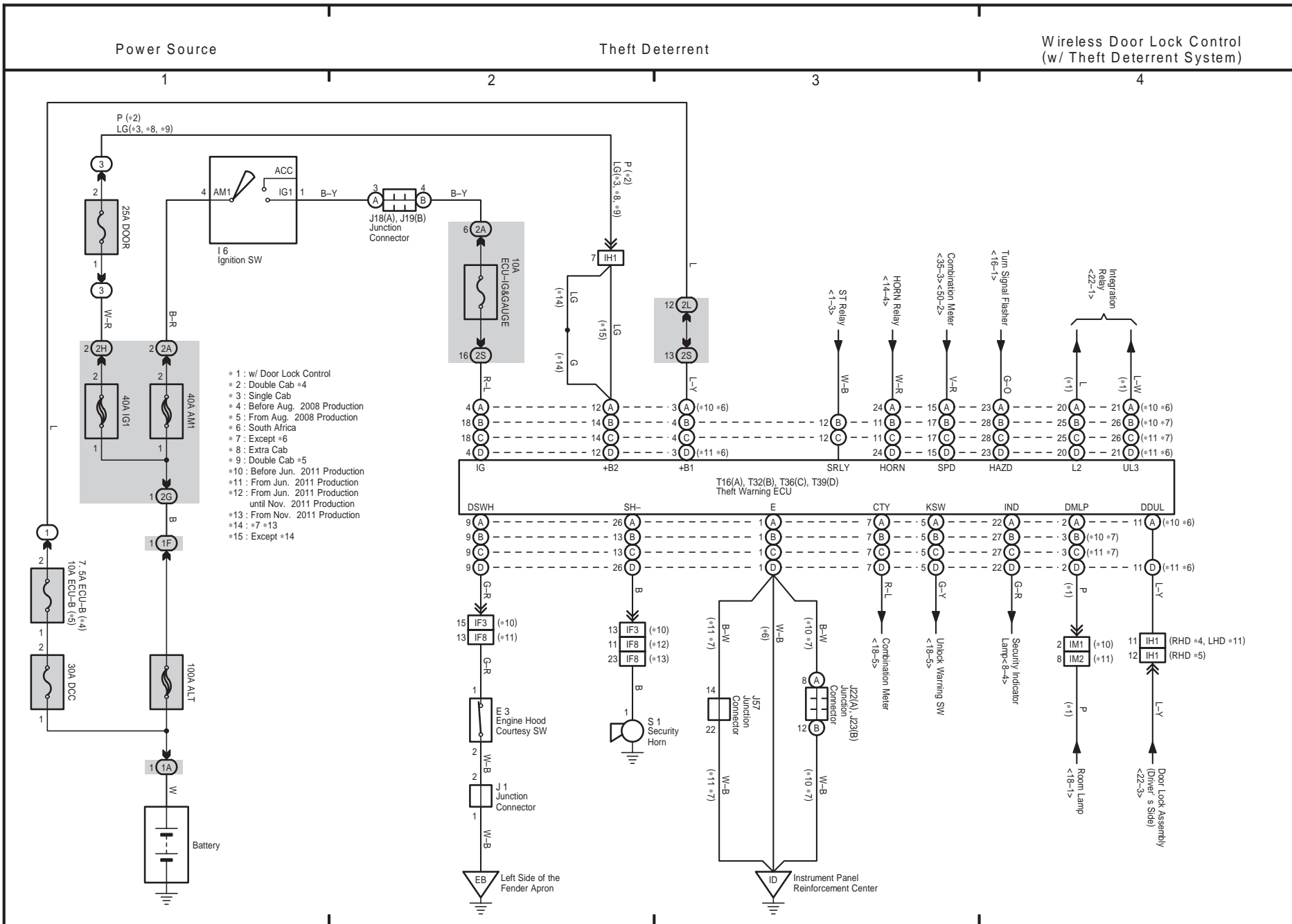

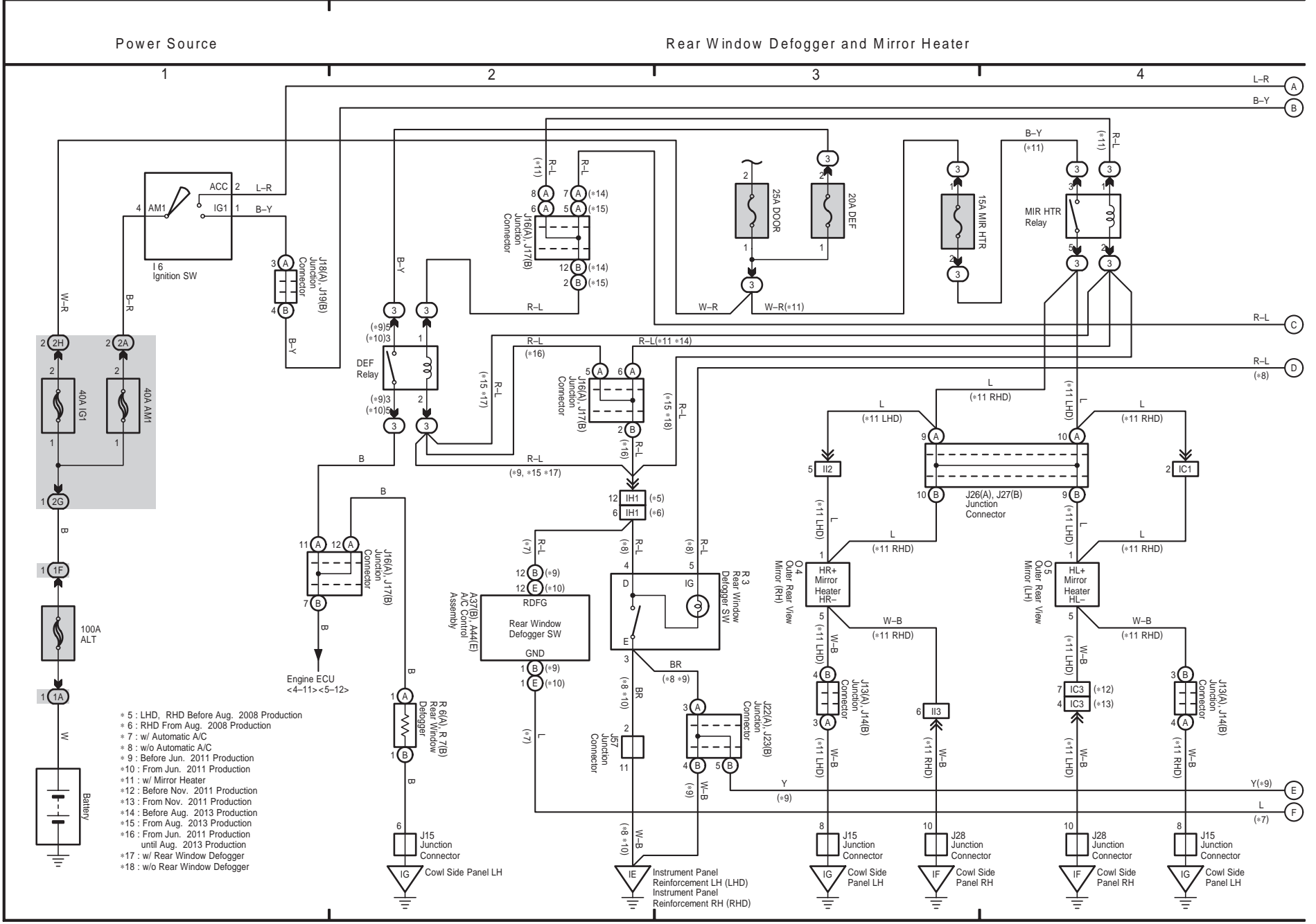

Shift Lock

- * 7 : w/ Automatic A/C
- * 8 : w/o Automatic A/C
- * 9 : Before Jun. 2011 Production
- *10 : From Jun. 2011 Production

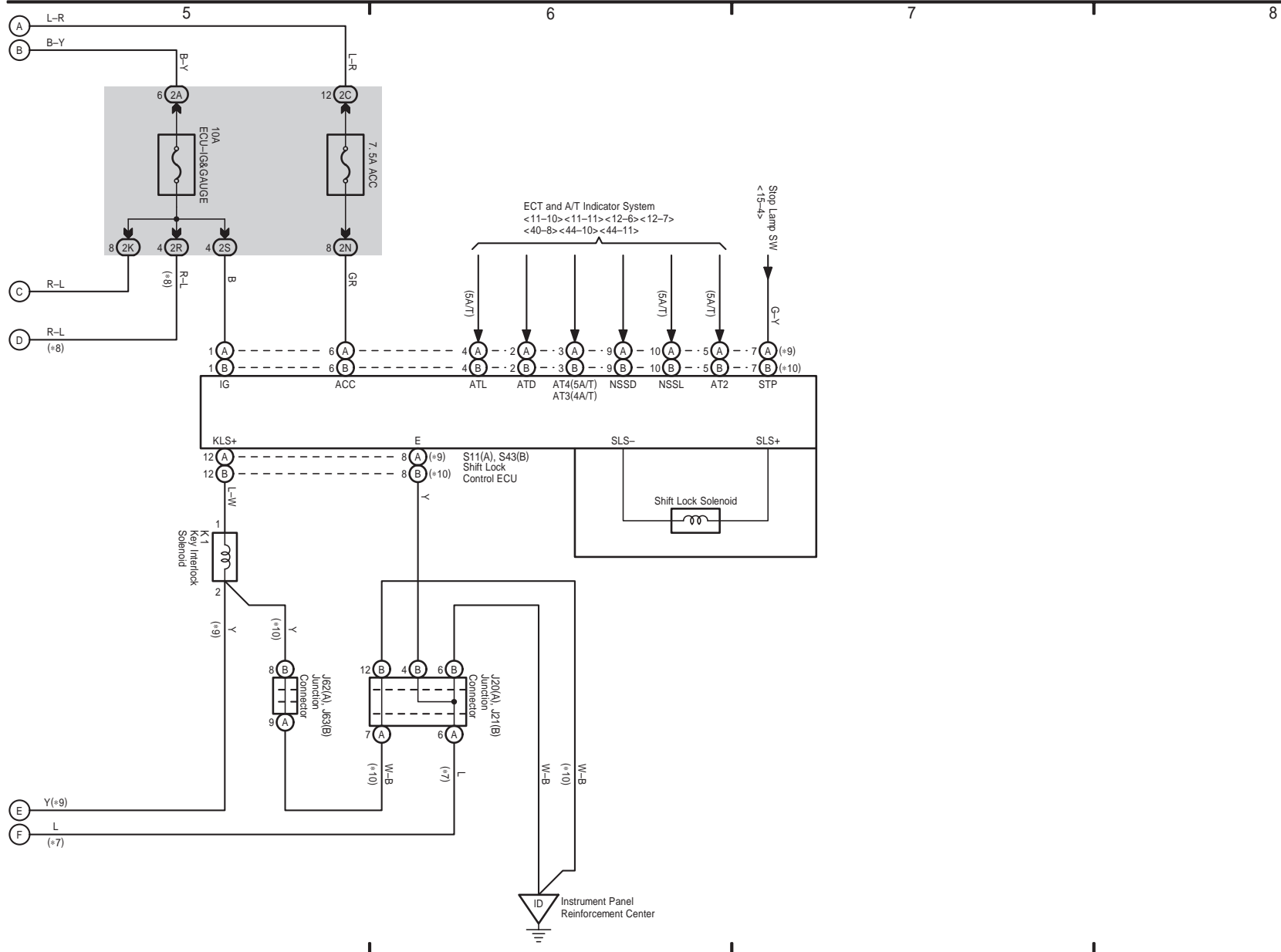

HILUX (EM1815E)

cardiagn.com

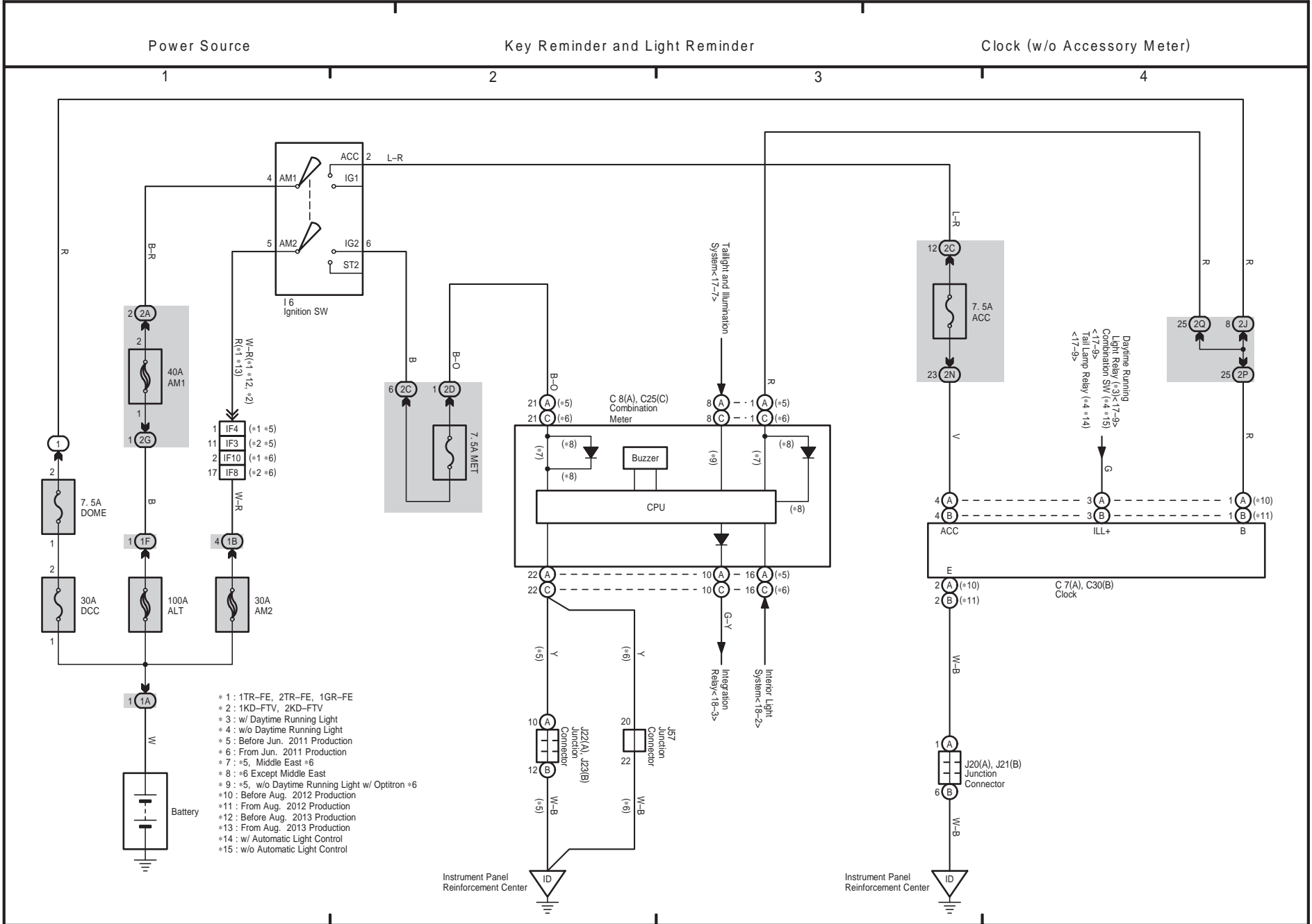

Power Source

Audio System, Navigation System and Parking Assist (Rear View Monitor)

: There is no wire color information.

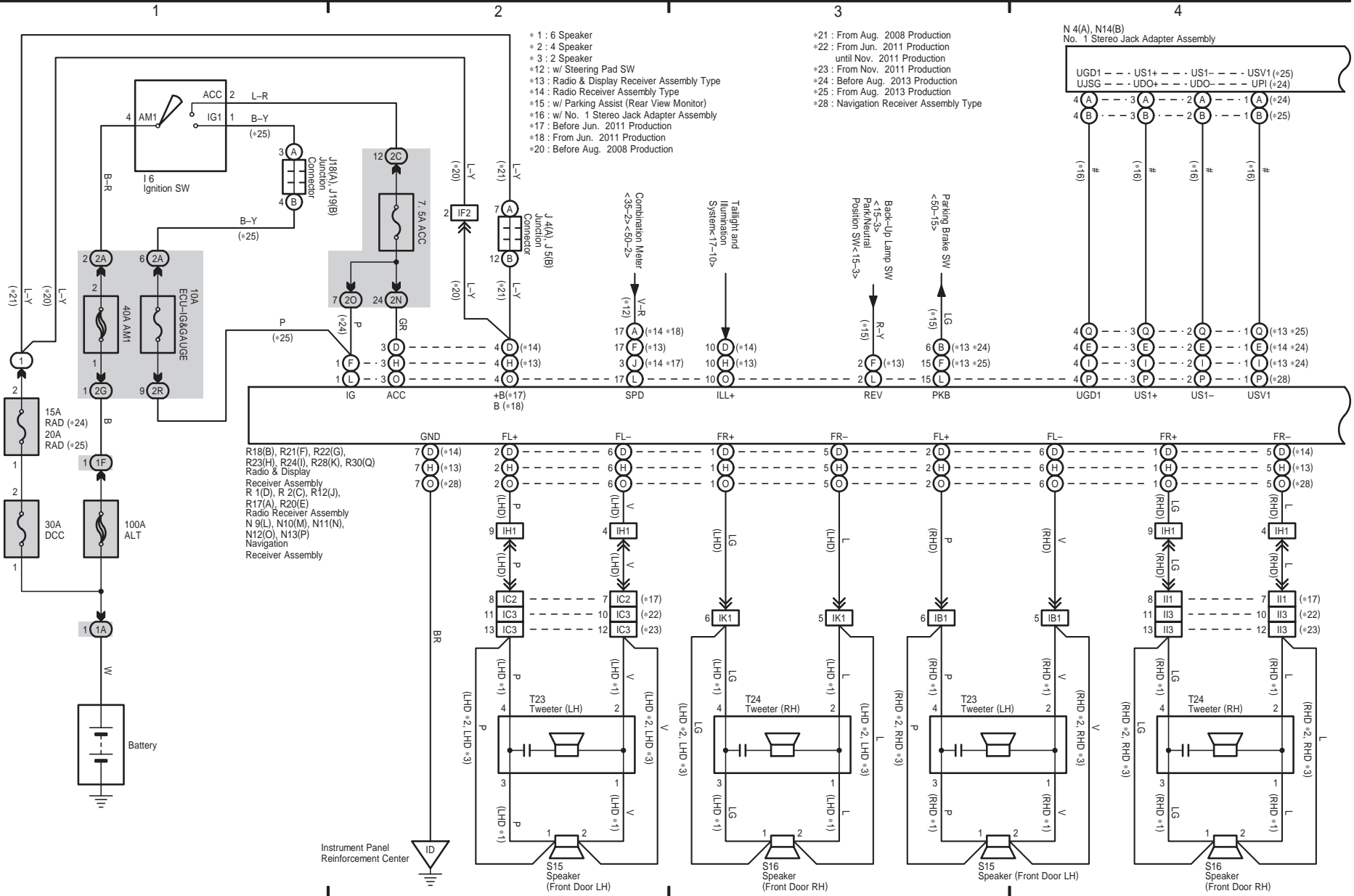

HILUX (EM1815E)

M OVERALL ELECTRICAL WIRING DIAGRAM

cardiagn.com

Audio System, Navigation System and Parking Assist (Rear View Monitor)

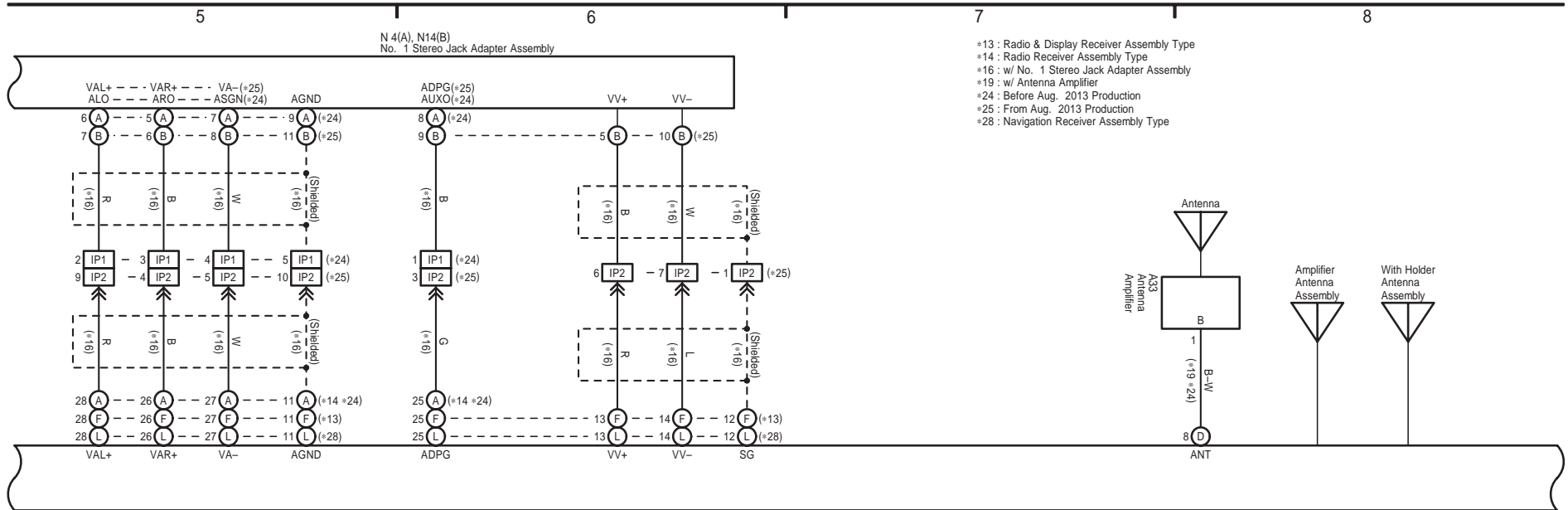

- *13 : Radio & Display Receiver Assembly Type
- *14 : Radio Receiver Assembly Type
- *16 : w/ No. 1 Stereo Jack Adapter Assembly
- *19 : w/ Antenna Amplifier
- *24 : Before Aug. 2013 Production
- *25 : From Aug. 2013 Production
- *28 : Navigation Receiver Assembly Type

R18(B), R21(F), R22(G),
 R23(H), R24(I), R28(K), R30(Q)
 Radio & Display
 Receiver Assembly
 R 1(D), R 2(C), R12(J),
 R17(A), R20(E)
 Radio Receiver Assembly
 N 9(L), N10(M), N11(N),
 N12(O), N13(P)
 Navigation
 Receiver Assembly

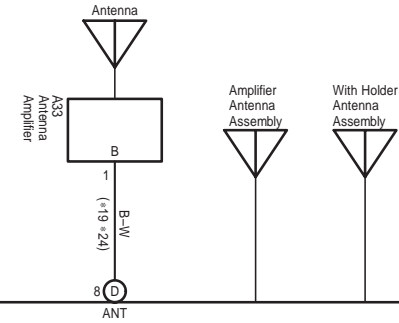

Audio System, Navigation System and Parking Assist (Rear View Monitor)

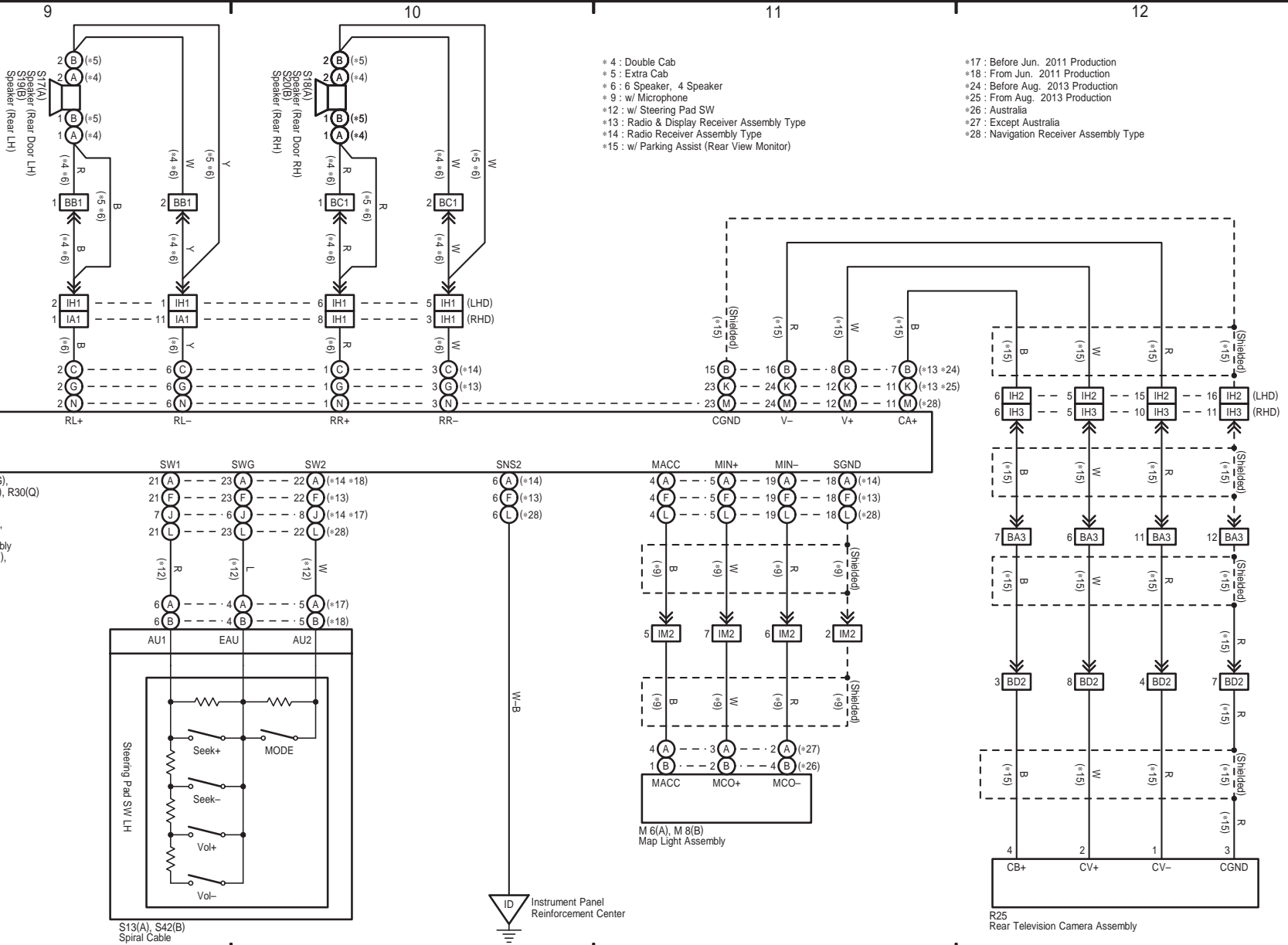

HILUX (EM1815E)

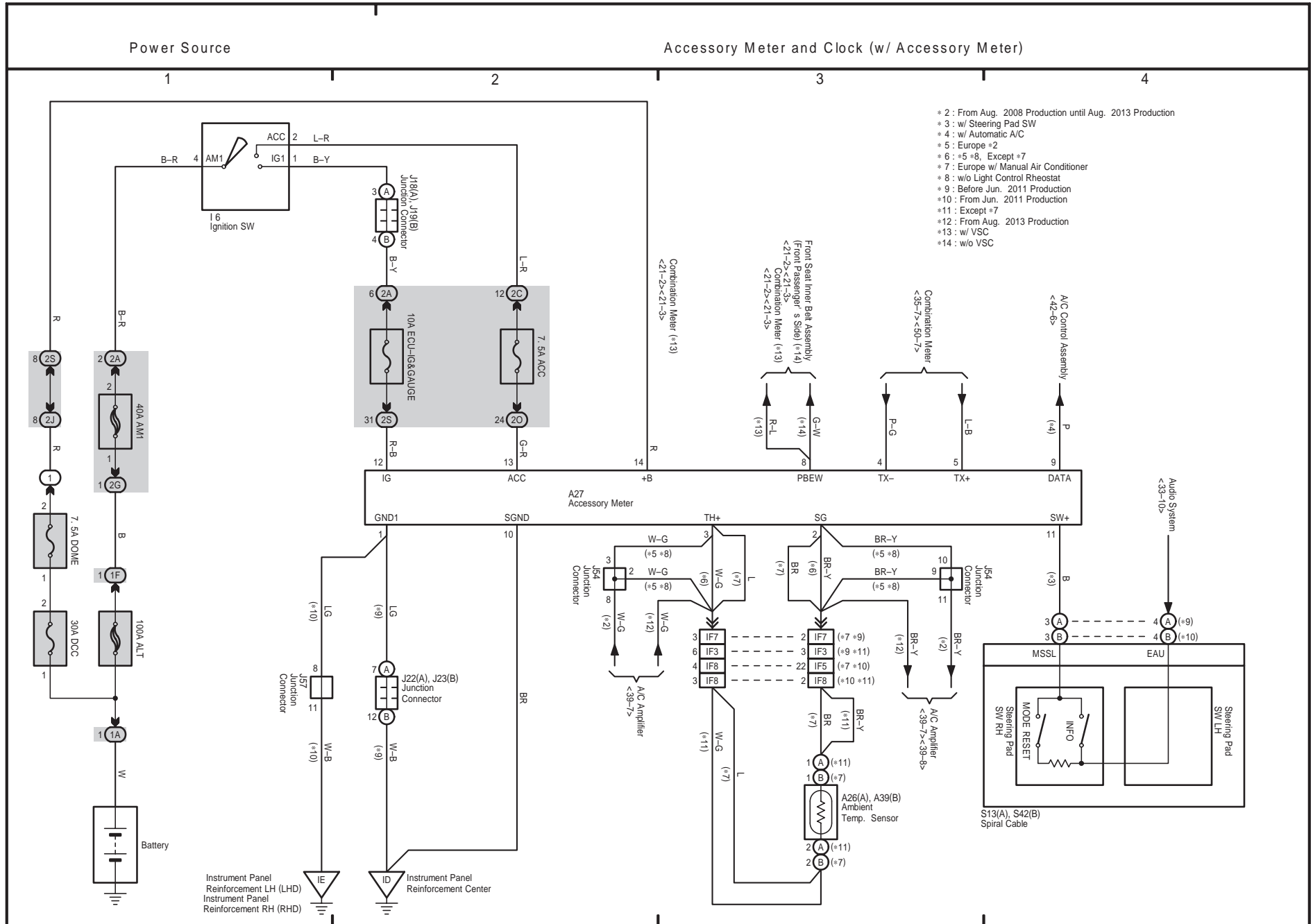

Combination Meter (Before Jun. 2011 Production)

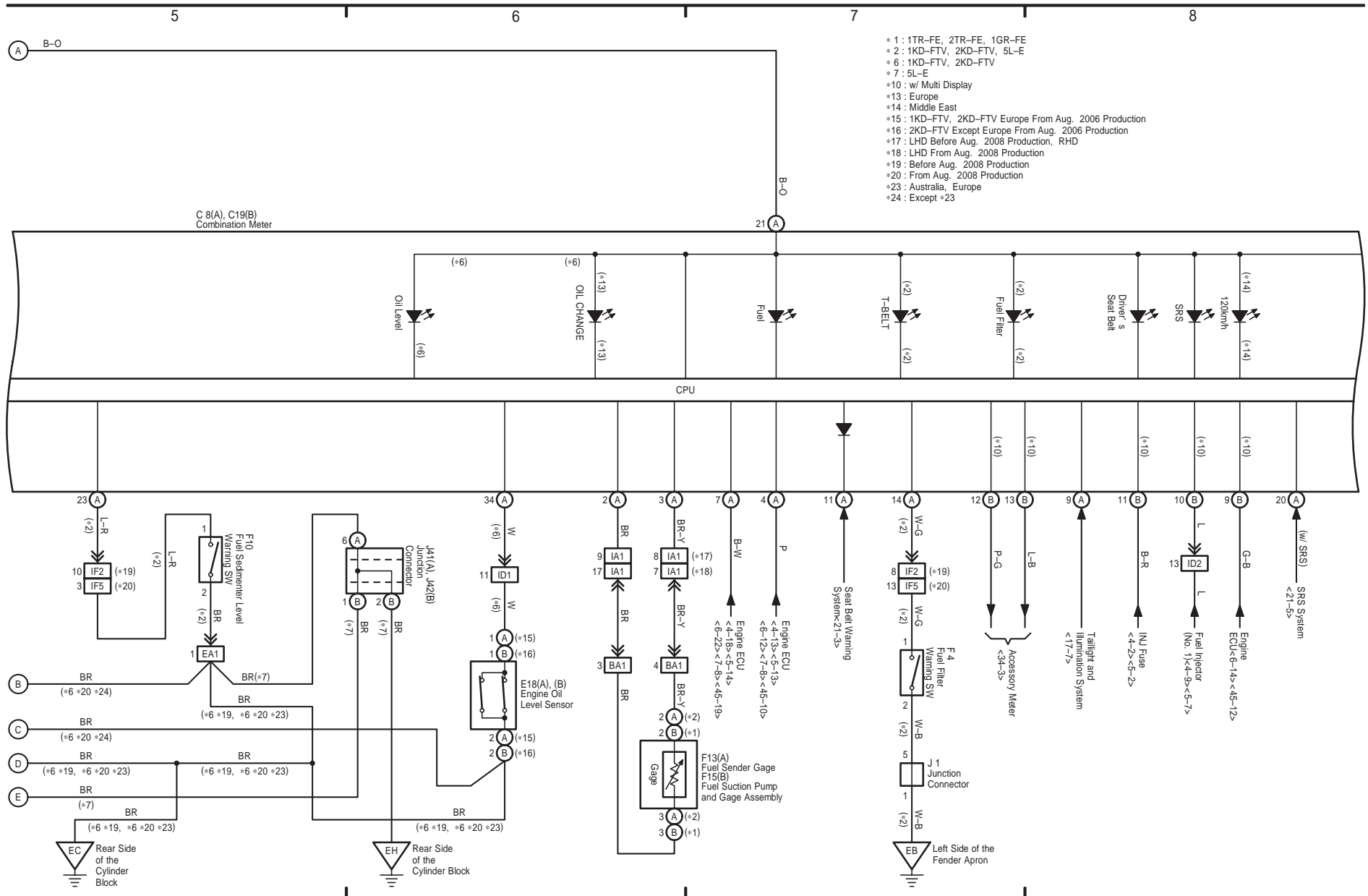

HILUX (EM1815E)

cardiagn.com

Combination Meter (Before Jun. 2011 Production)

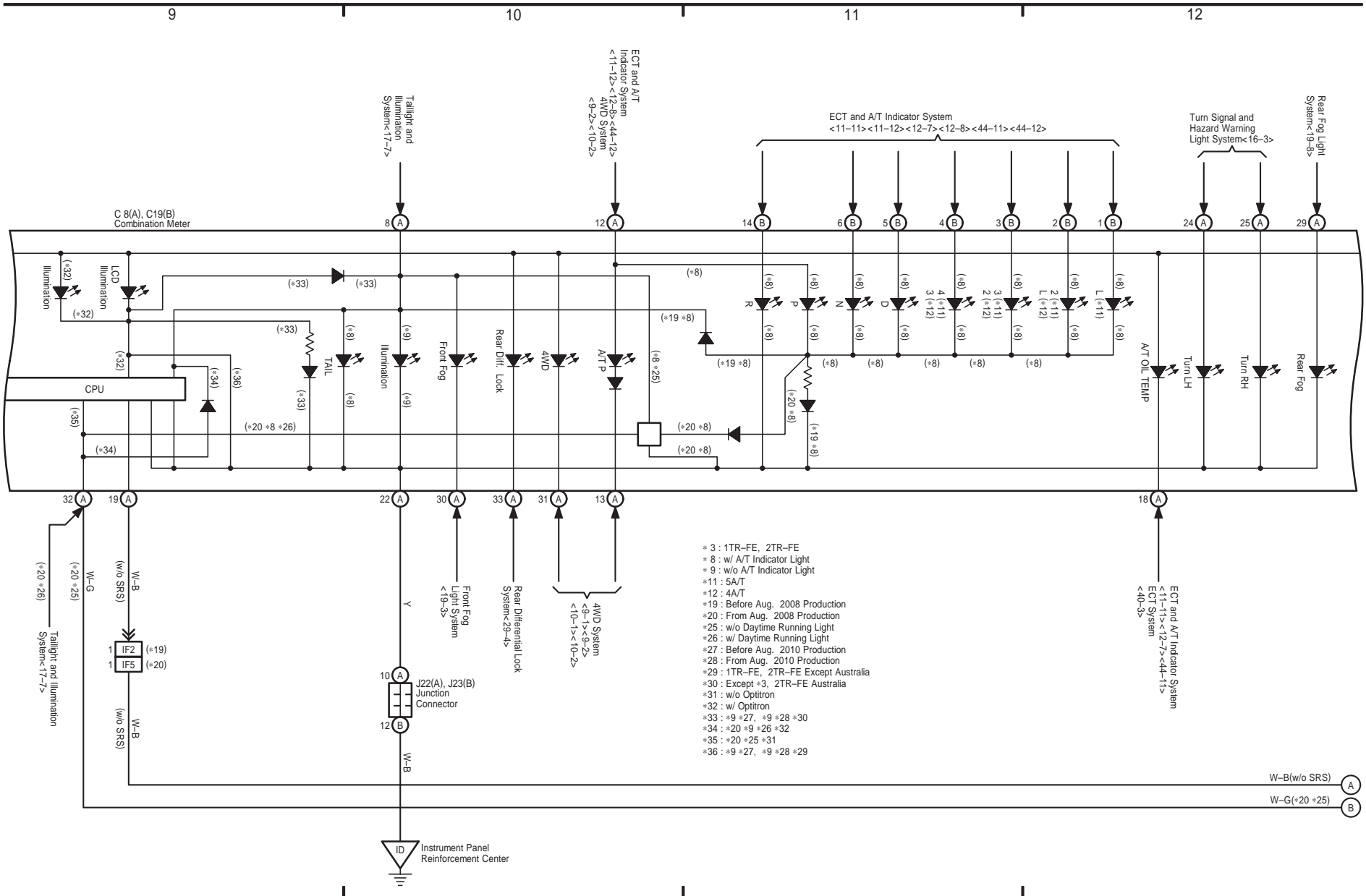

- * 3 : 1TR-FE, 2TR-FE
- * 8 : w/ A/T Indicator Light
- * 9 : w/o A/T Indicator Light
- * 11 : 5A/T
- * 12 : 4A/T
- * 19 : Before Aug. 2008 Production
- * 20 : From Aug. 2008 Production
- * 25 : w/o Daytime Running Light
- * 26 : w/ Daytime Running Light
- * 27 : Before Aug. 2010 Production
- * 28 : From Aug. 2010 Production
- * 29 : 1TR-FE, 2TR-FE Except Australia
- * 30 : Except *3, 2TR-FE Australia
- * 31 : w/o Optitron
- * 32 : w/ Optitron
- * 33 : *9 *27, *9 *28 *30
- * 34 : *20 *9 *26 *32
- * 35 : *20 *25 *31
- * 36 : *9 *27, *9 *28 *29

HILUX (EM1815E)

Combination Meter (Before Jun. 2011 Production)

13

14

15

16

- * 2 : 1KD-FTV, 2KD-FTV, 5L-E
- * 7 : 5L-E
- *19 : Before Aug. 2008 Production
- *20 : From Aug. 2008 Production
- *21 : w/ VSC
- *22 : w/o VSC
- *25 : w/o Daytime Running Light

C 8(A), C19(B)
Combination Meter

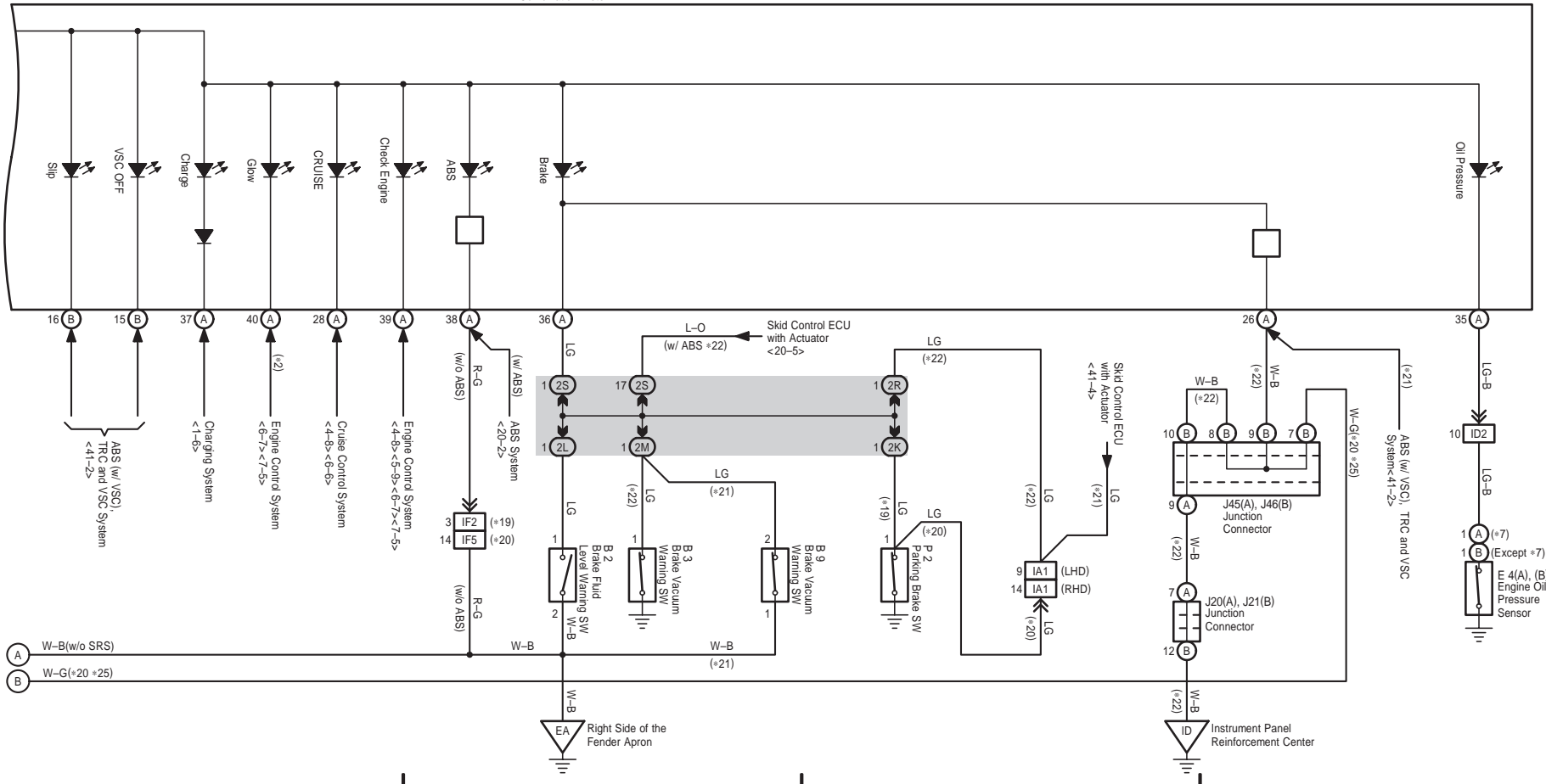

HILUX (EM1815E)

cardiagn.com

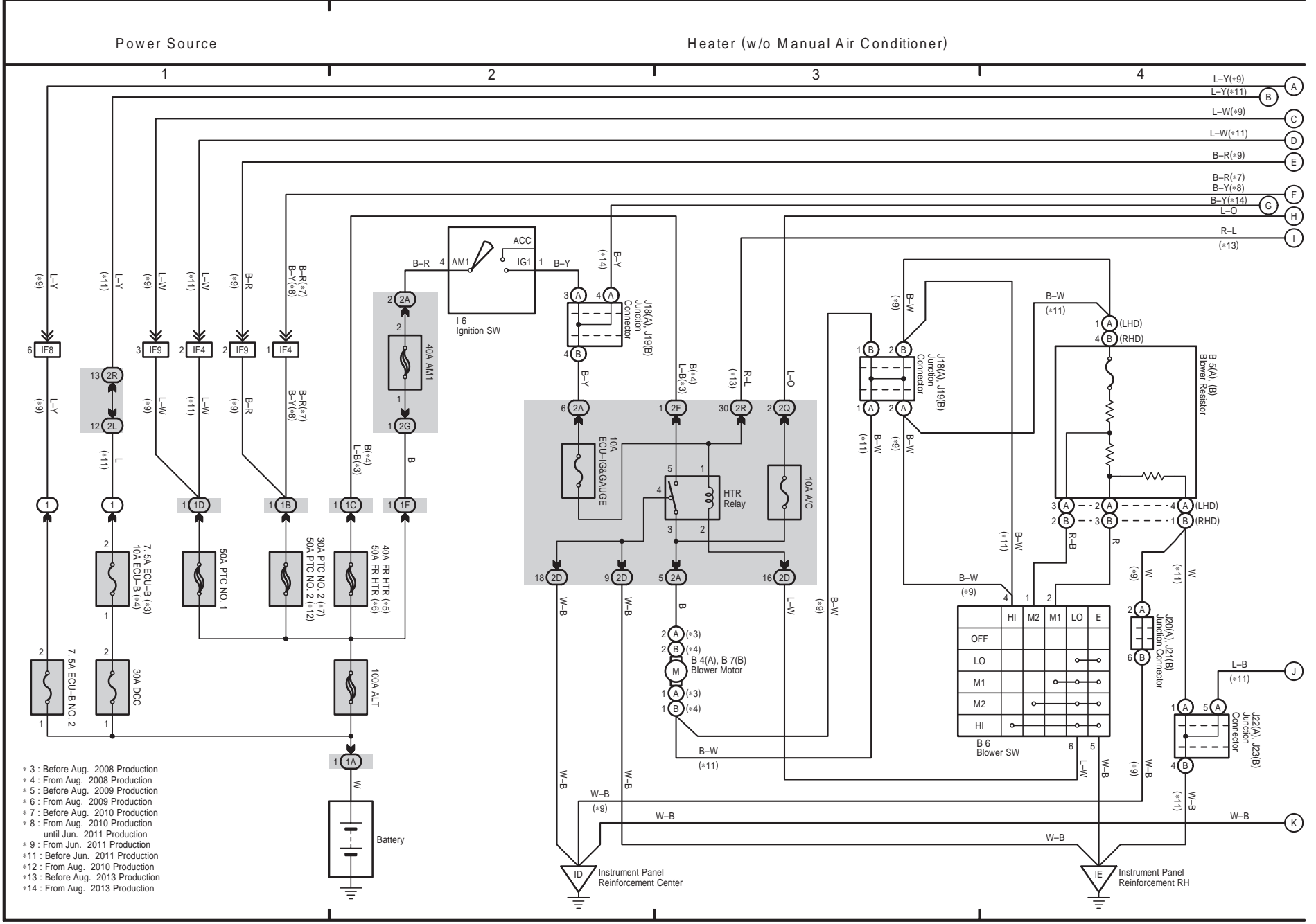

- * 3 : Before Aug. 2008 Production
- * 4 : From Aug. 2008 Production
- * 5 : Before Aug. 2009 Production
- * 6 : From Aug. 2009 Production
- * 7 : Before Aug. 2010 Production
- * 8 : From Aug. 2010 Production until Jun. 2011 Production
- * 9 : From Jun. 2011 Production
- * 11 : Before Jun. 2011 Production
- * 12 : From Aug. 2010 Production
- * 13 : Before Aug. 2013 Production
- * 14 : From Aug. 2013 Production

PTC Heater (Cold Area Spec. w/o Manual Air Conditioner)

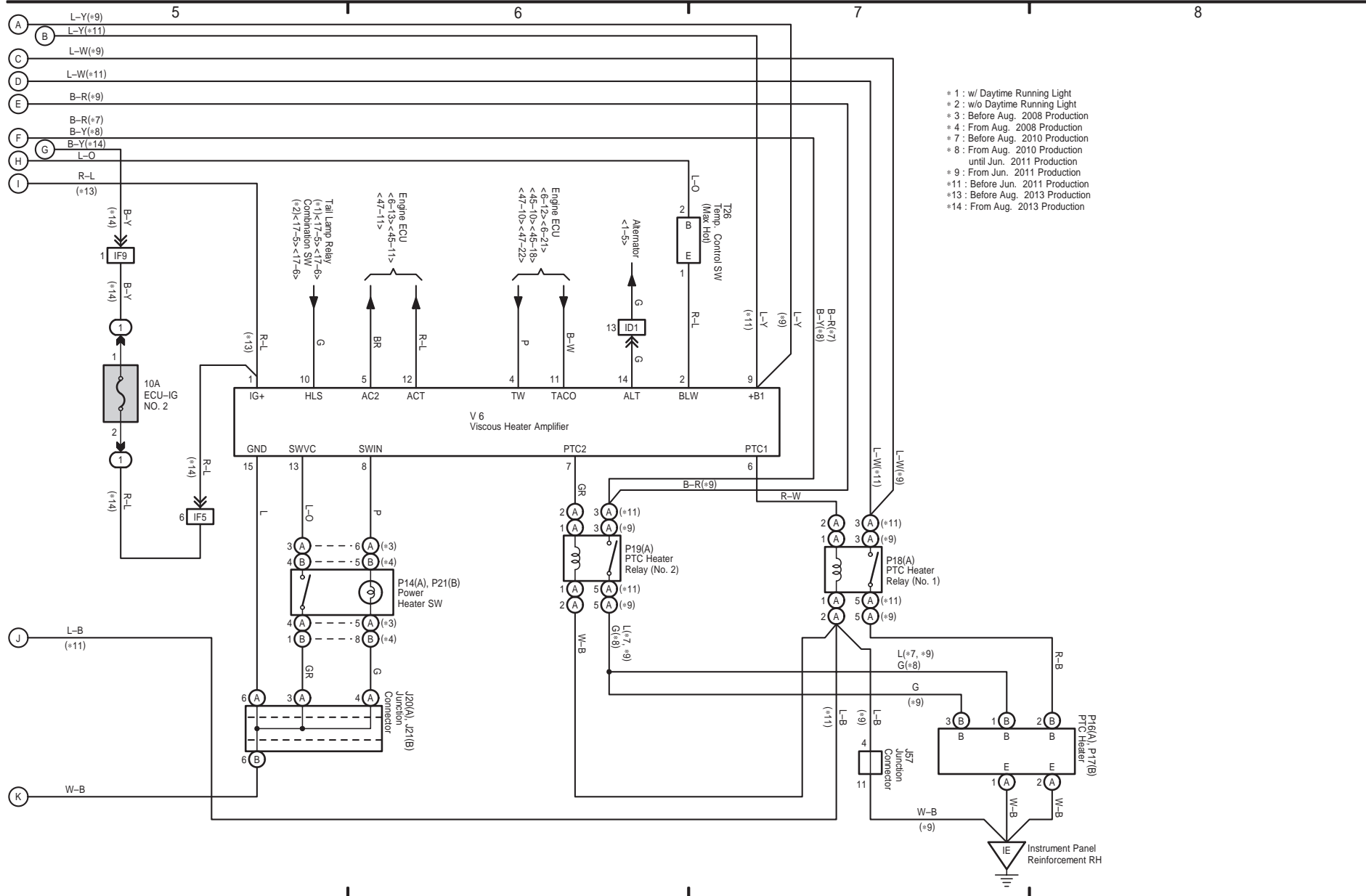

- * 1 : w/ Daytime Running Light
- * 2 : w/o Daytime Running Light
- * 3 : Before Aug. 2008 Production
- * 4 : From Aug. 2008 Production
- * 7 : Before Aug. 2010 Production
- * 8 : From Aug. 2010 Production until Jun. 2011 Production
- * 9 : From Jun. 2011 Production
- * 11 : Before Jun. 2011 Production
- * 13 : Before Aug. 2013 Production
- * 14 : From Aug. 2013 Production

HILUX (EM1815E)

cardiagn.com

HILUX (EM1815E)

M OVERALL ELECTRICAL WIRING DIAGRAM

cardiagn.com

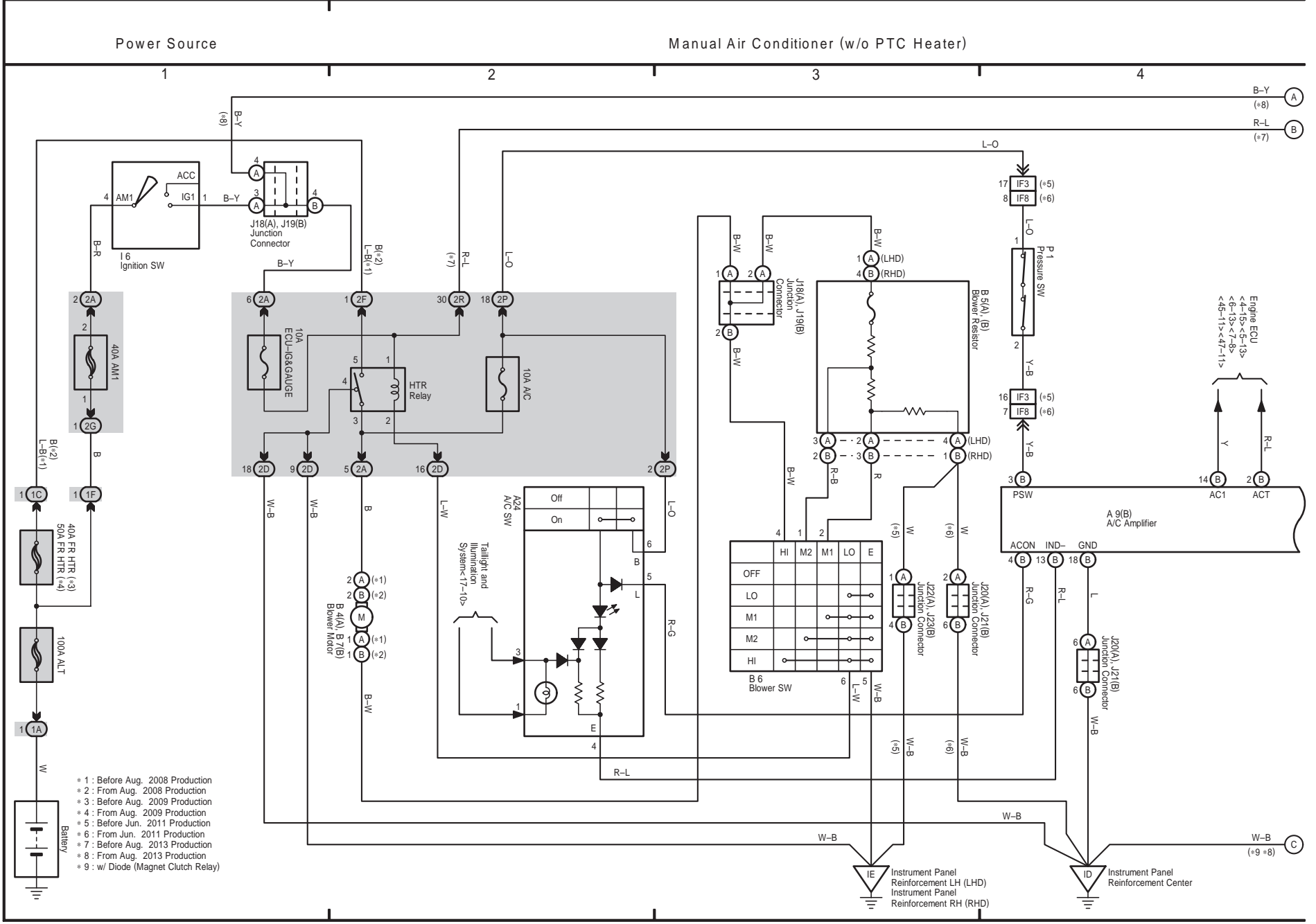

Manual Air Conditioner (w/o PTC Heater)

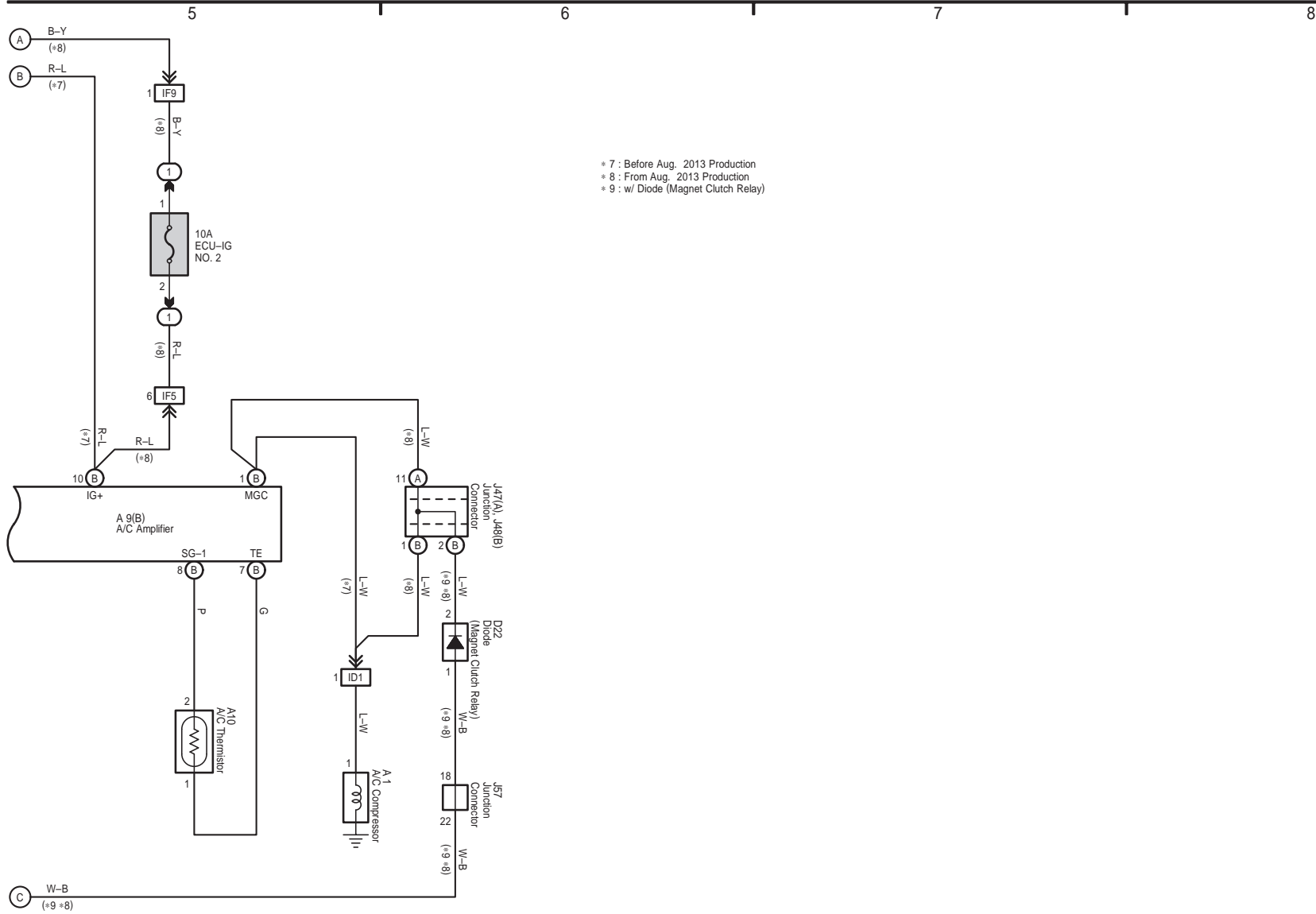

* 7 : Before Aug. 2013 Production
 * 8 : From Aug. 2013 Production
 * 9 : w/ Diode (Magnet Clutch Relay)

Manual Air Conditioner
(Australia w/ PTC Heater,
Europe Except Cold Area Spec.)

PTC Heater (Australia, Europe Except Cold Area Spec.)

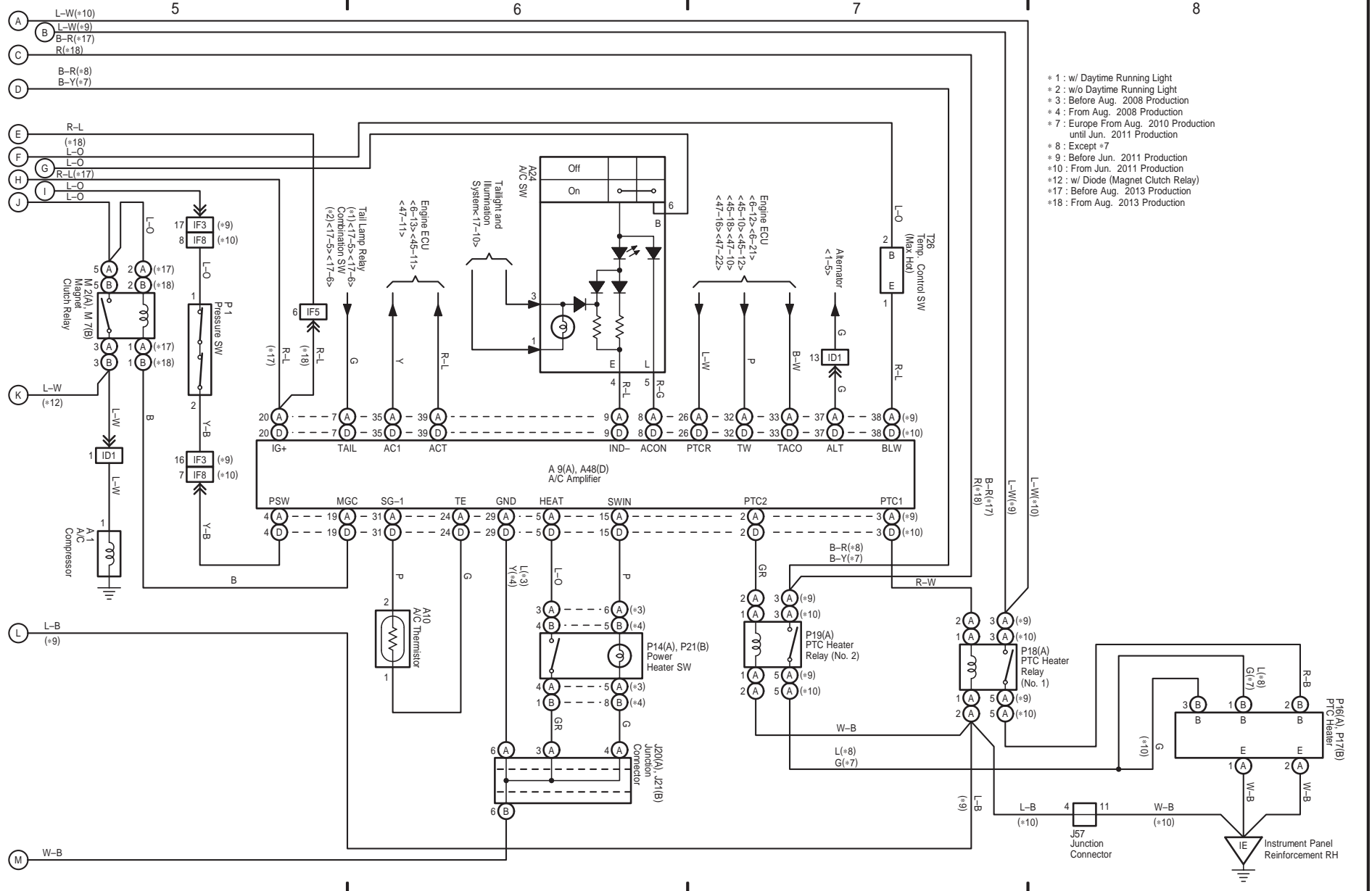

HILUX (EM1815E)

cardiagn.com

Manual Air Conditioner
(Cold Area Spec.)

PTC Heater (Cold Area Spec. w/ Manual Air Conditioner)

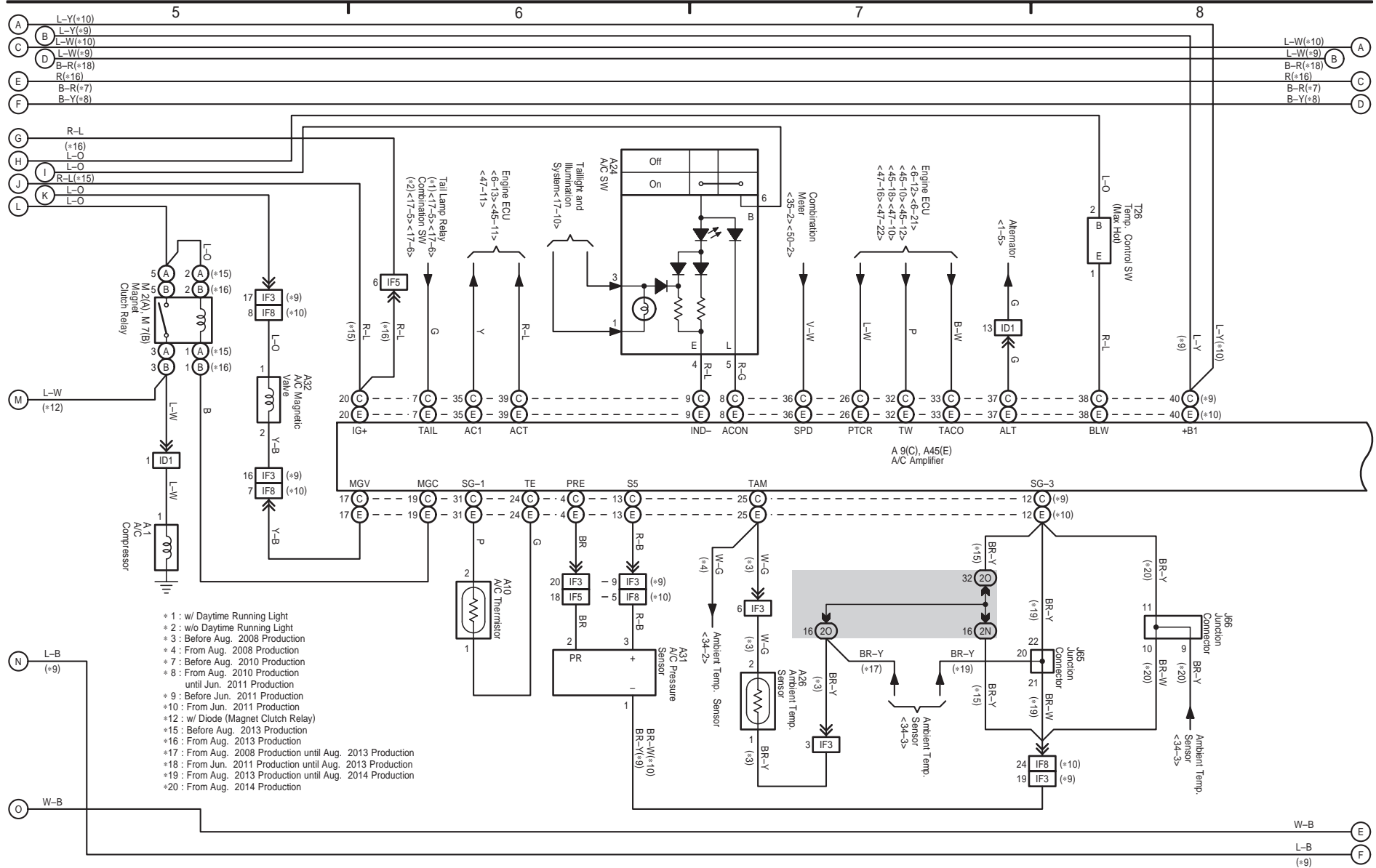

HILUX (EM1815E)

cardiagn.com

PTC Heater (Cold Area Spec. w/ Manual Air Conditioner)

9 10 11 12

- (A) L-W(+10)
- (B) L-W(+9)
- (C) B-R(+18)
- (D) R(+16)
- (E) B-R(+7)
- (F) B-Y(+8)

- * 3 : Before Aug. 2008 Production
- * 4 : From Aug. 2008 Production
- * 7 : Before Aug. 2010 Production
- * 8 : From Aug. 2010 Production until Jun. 2011 Production
- * 9 : Before Jun. 2011 Production
- * 10 : From Jun. 2011 Production
- * 16 : From Aug. 2013 Production
- * 18 : From Jun. 2011 Production until Aug. 2013 Production

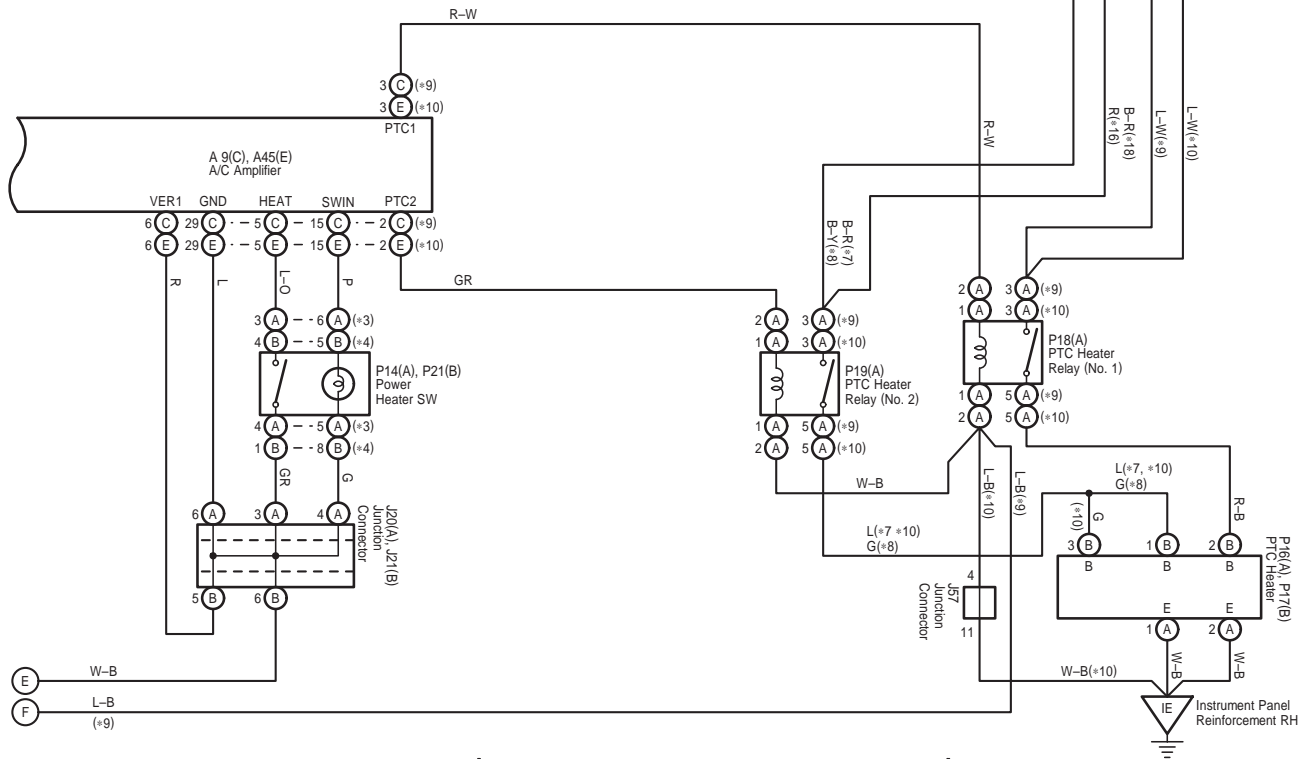

HILUX (EM1815E)

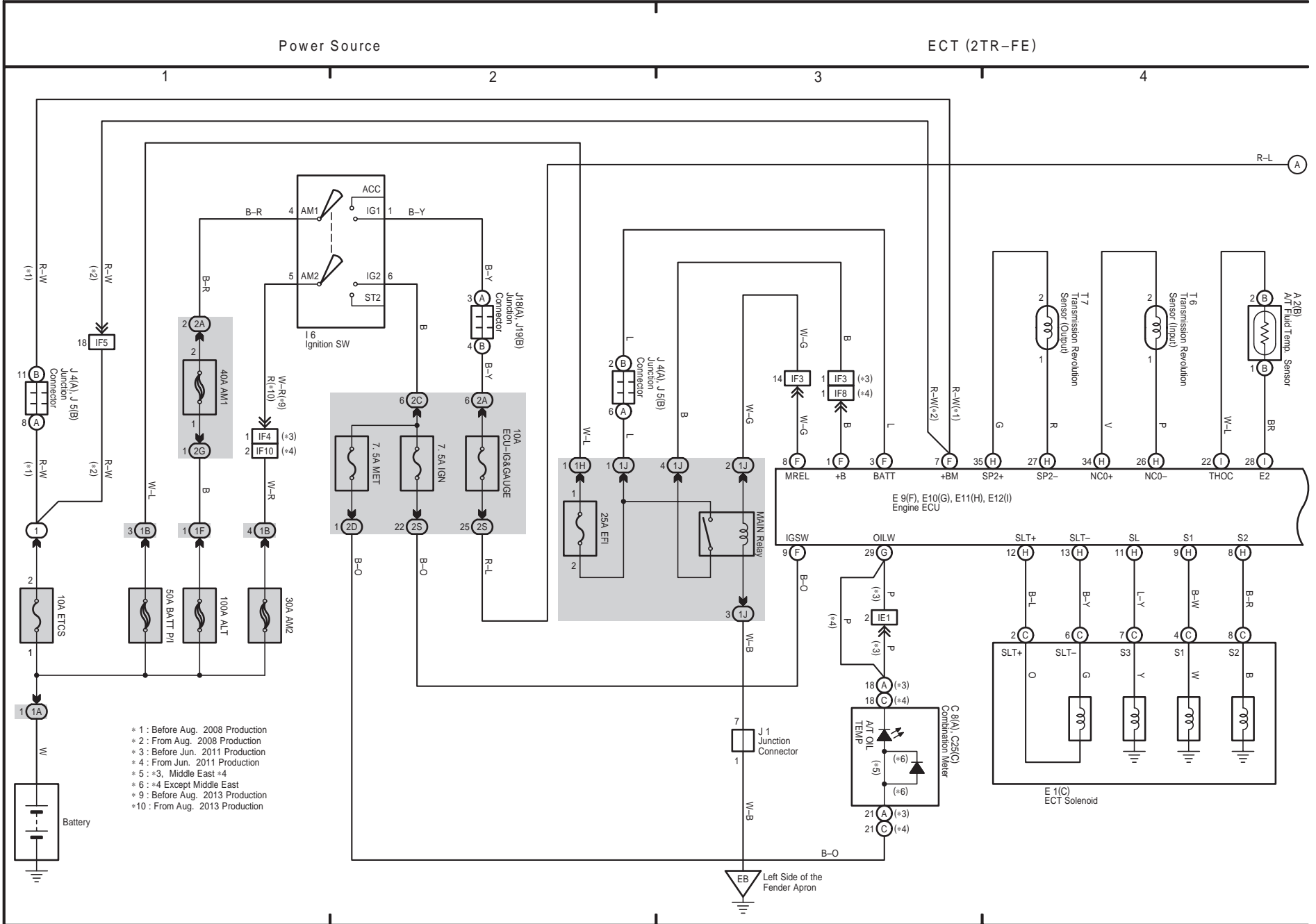

HILUX (EM1815E)

M OVERALL ELECTRICAL WIRING DIAGRAM

cardiagn.com

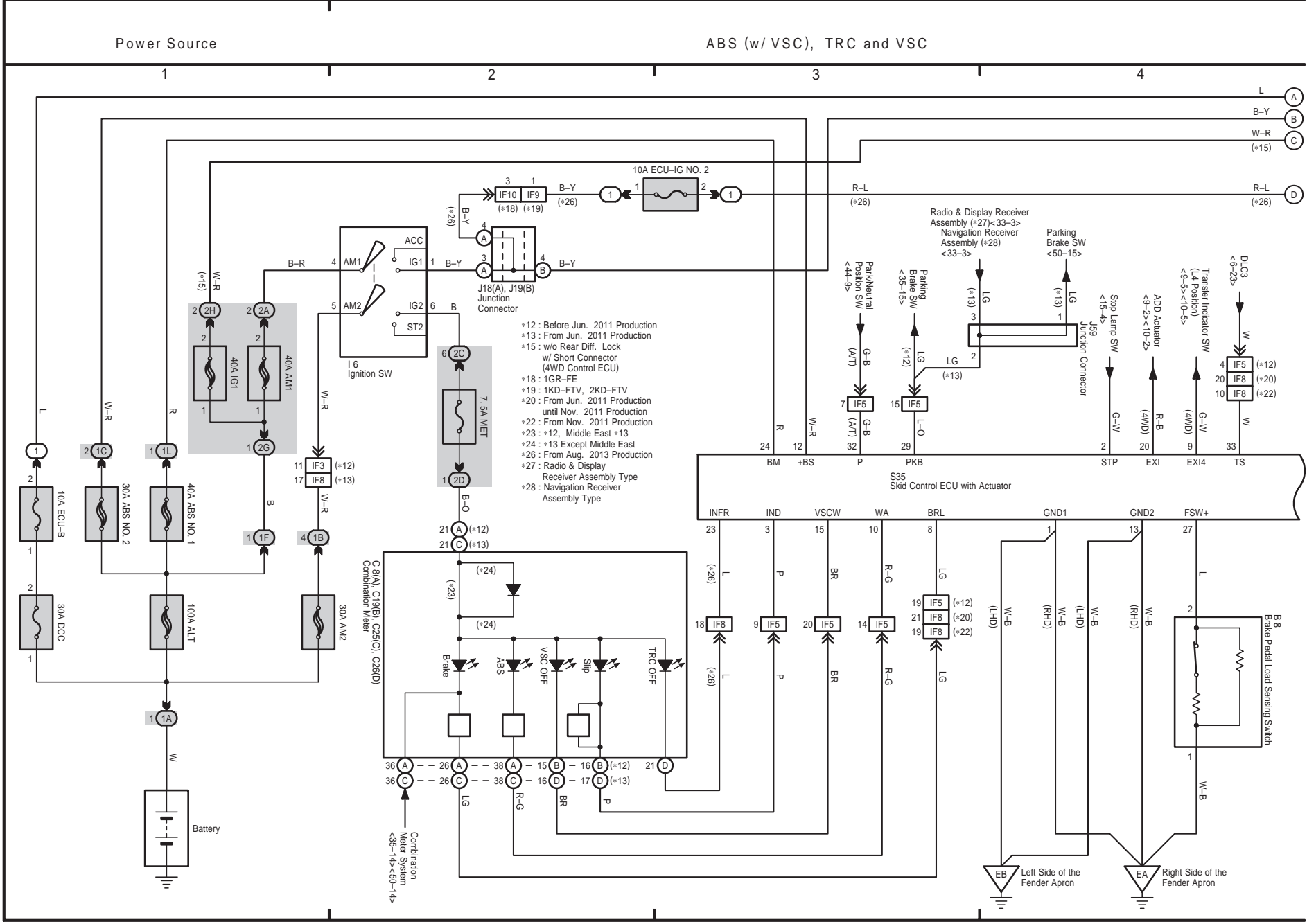

ABS (w/ VSC), TRC and VSC

Multiplex Communication System (CAN)

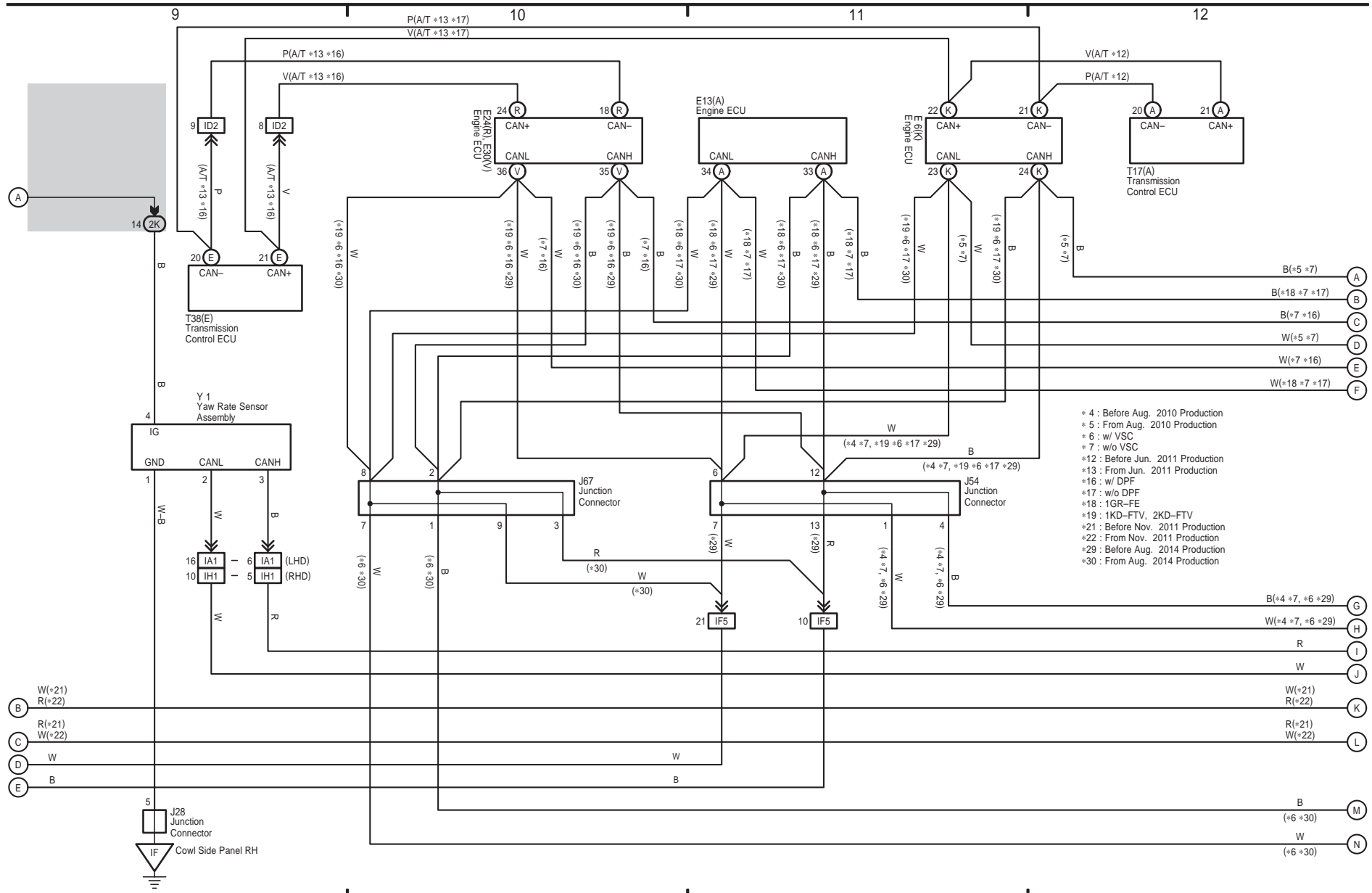

HILUX (EM1815E)

Multiplex Communication System (CAN)

13

14

15

16

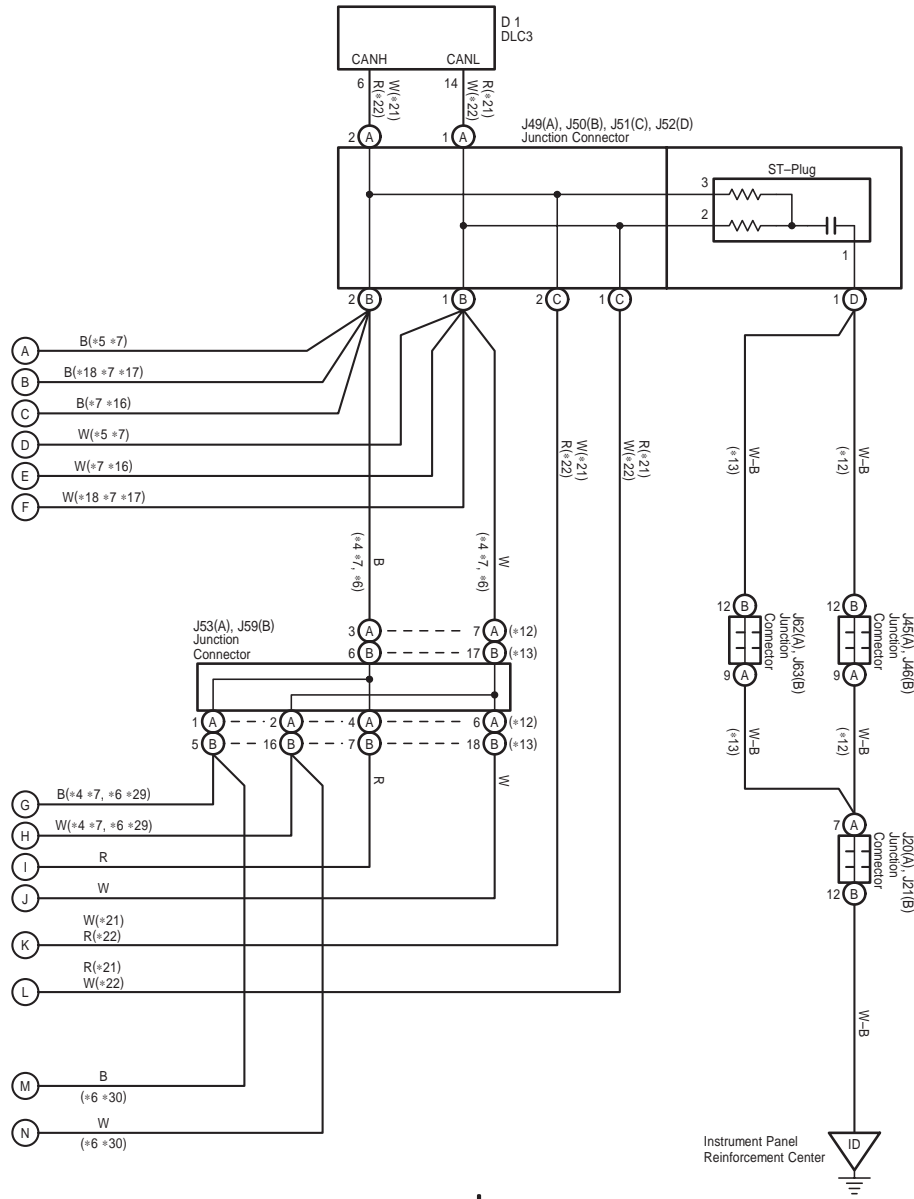

- * 4 : Before Aug. 2010 Production
- * 5 : From Aug. 2010 Production
- * 6 : w/ VSC
- * 7 : w/o VSC
- *12 : Before Jun. 2011 Production
- *13 : From Jun. 2011 Production
- *16 : w/ DPF
- *17 : w/o DPF
- *18 : 1GR-FE
- *21 : Before Nov. 2011 Production
- *22 : From Nov. 2011 Production
- *29 : Before Aug. 2014 Production
- *30 : From Aug. 2014 Production

HILUX (EM1815E)

cardiagn.com

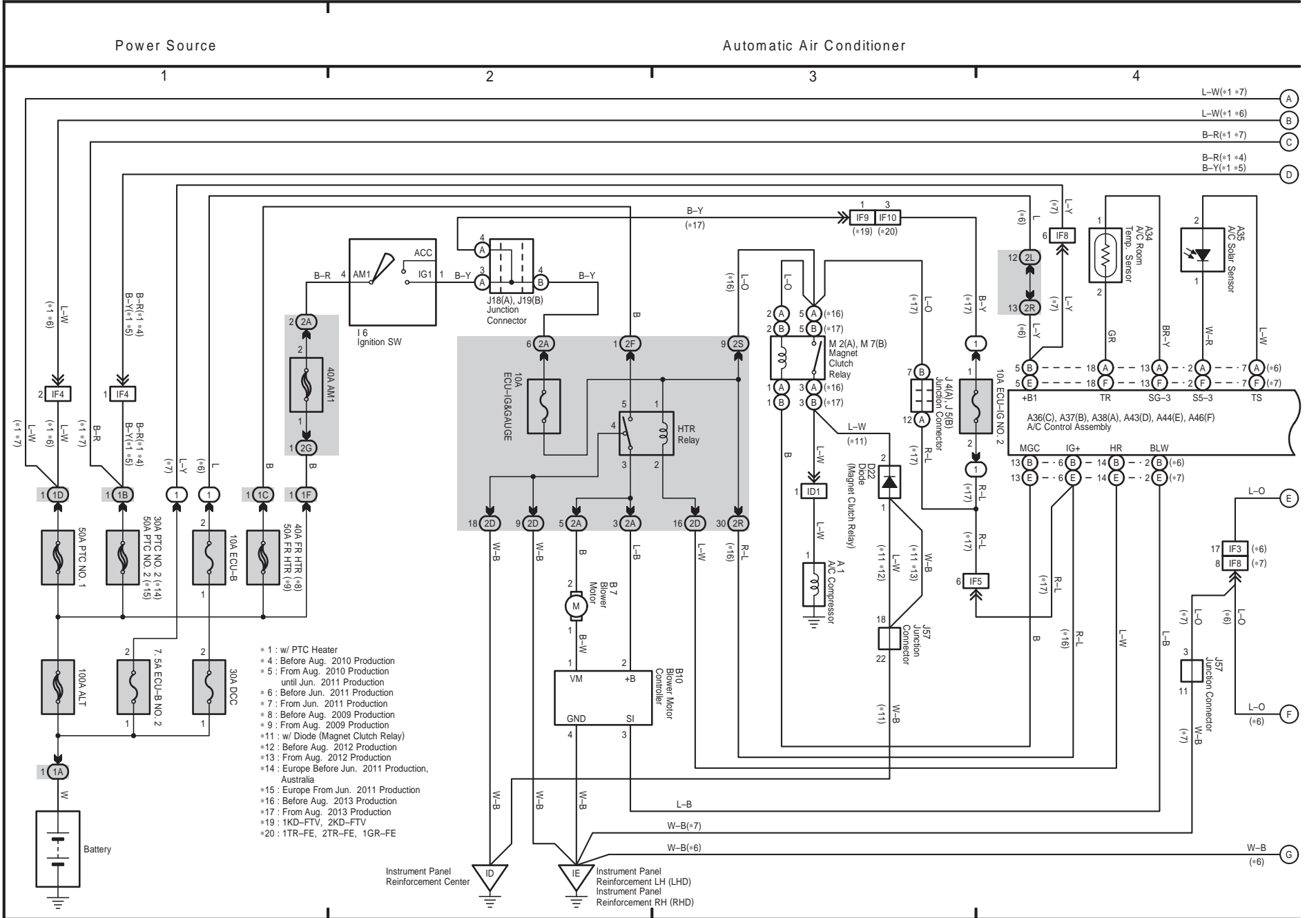

Automatic Air Conditioner

HILUX (EM1815E)

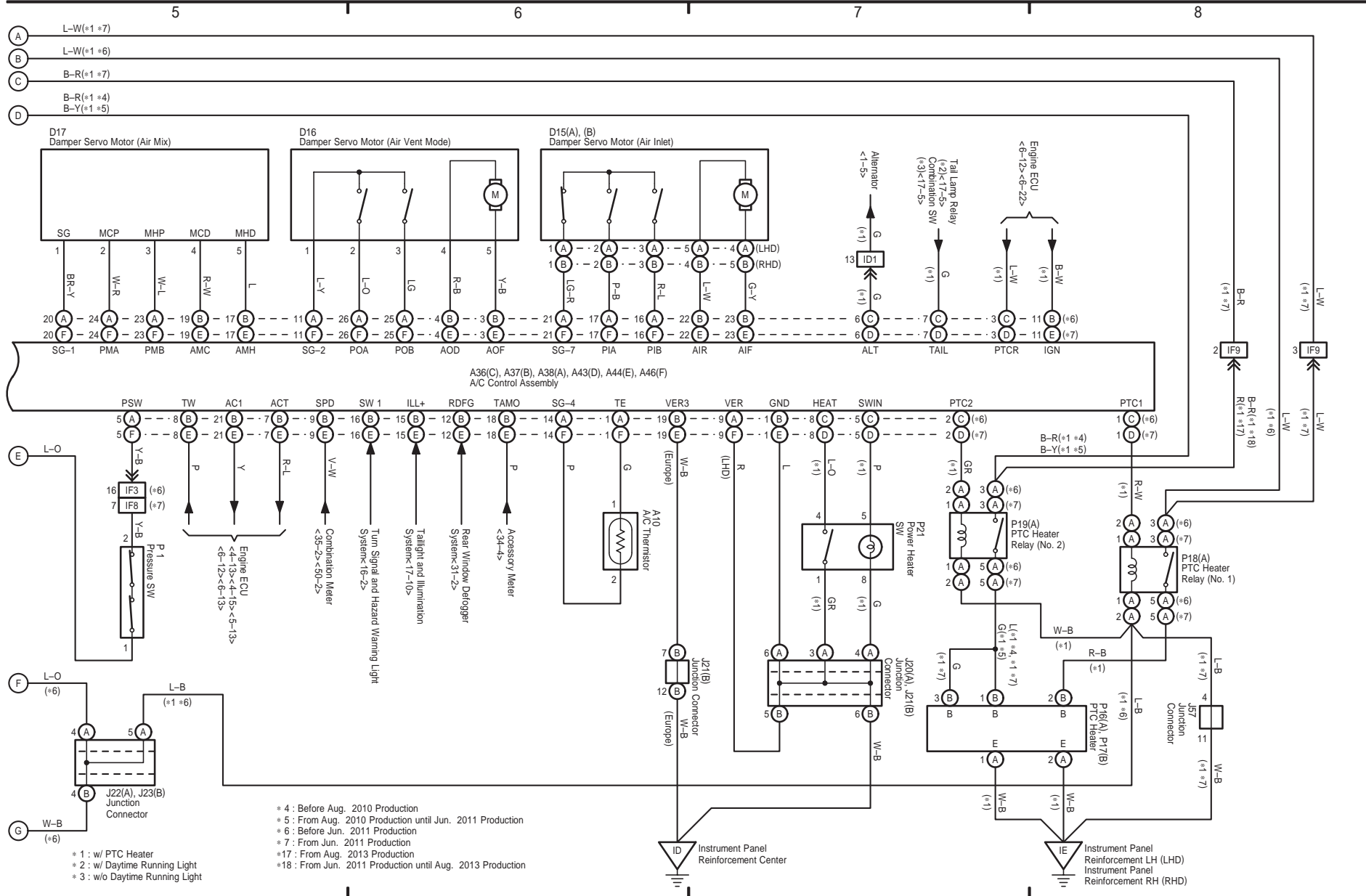

43 HILUX

Power Source

Headlight Cleaner

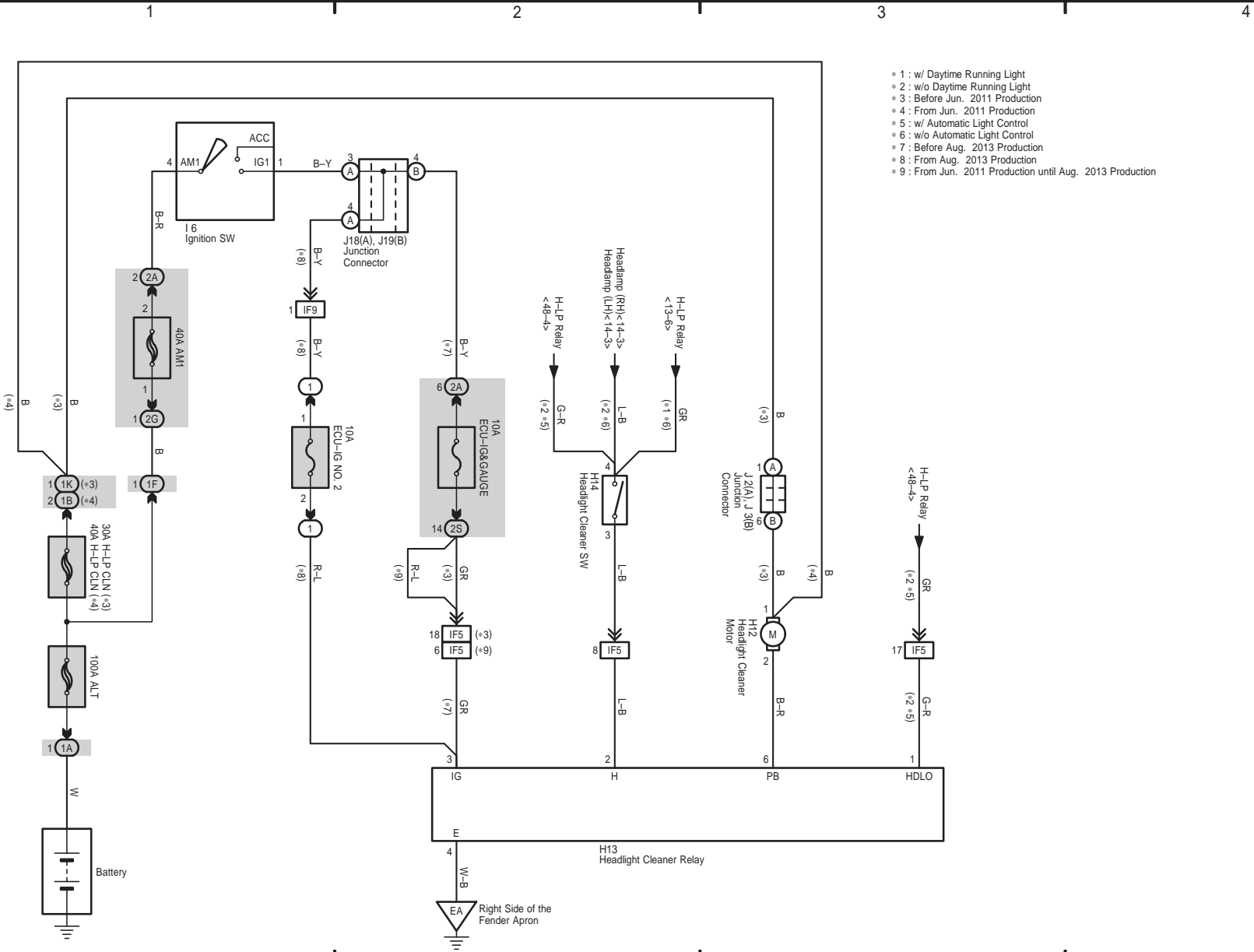

ECT and A/T Indicator (1KD-FTV 5A/T)

* 7 : w/ Option Connector (Daytime Running Light)
* 8 : w/o Option Connector (Daytime Running Light)

5 | 6 | 7 | 8

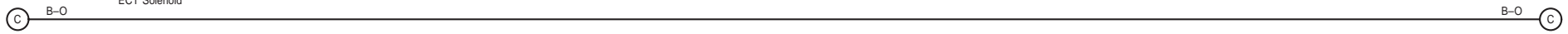
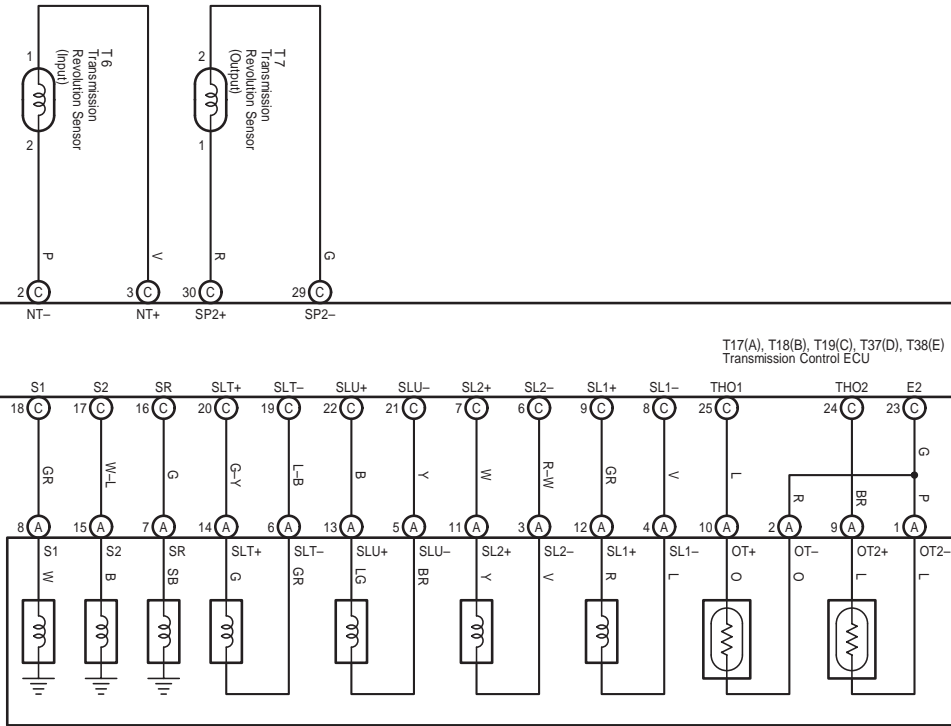
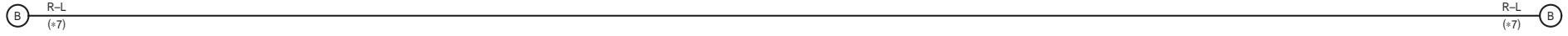
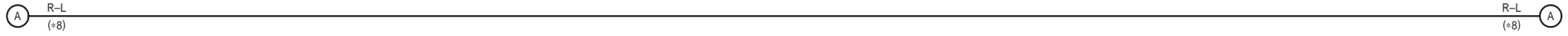

HILUX (EM1815E)

cardiagn.com

ECT and A/T Indicator (1KD-FTV 5A/T)

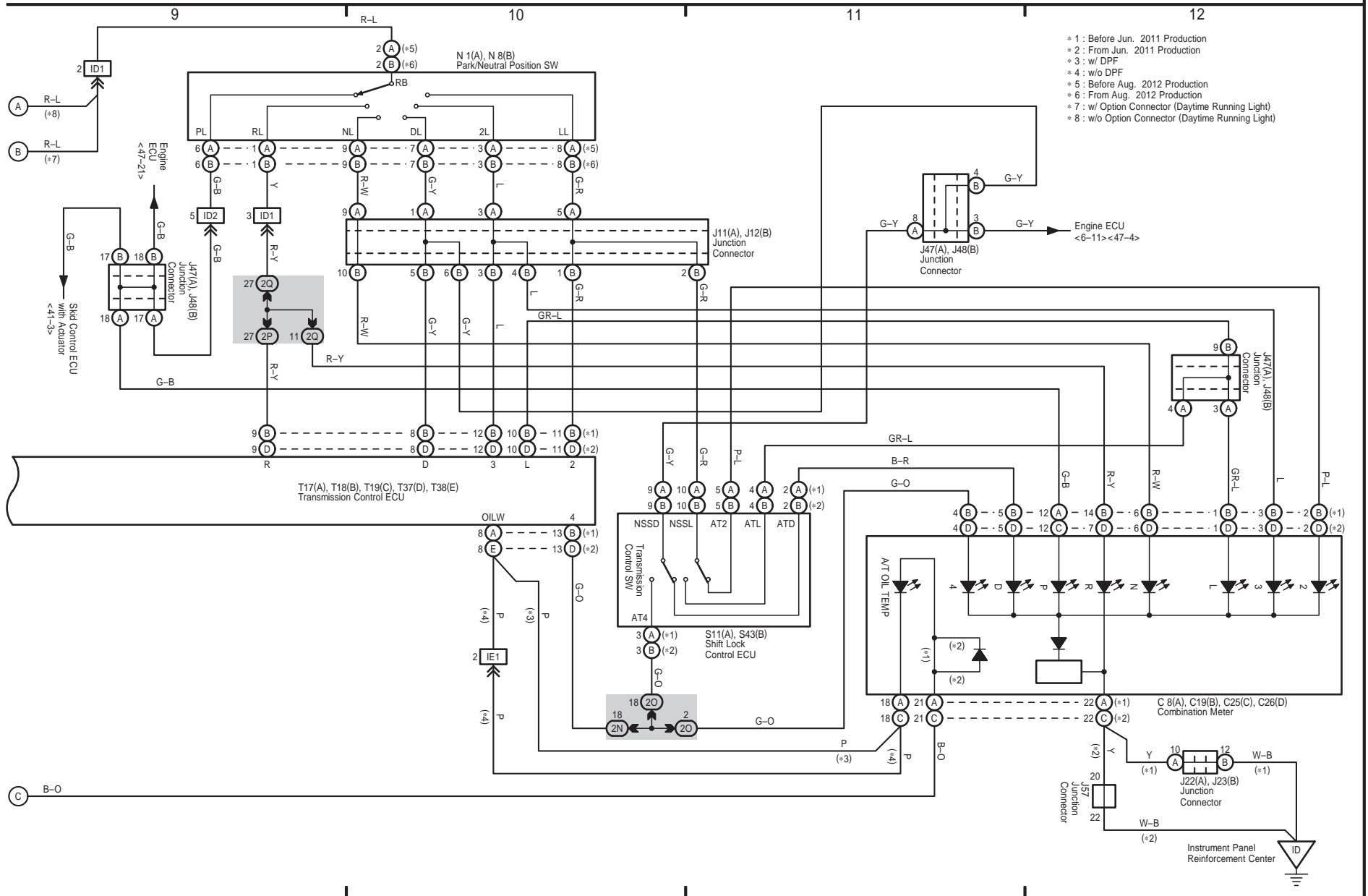

HILUX (EM1815E)

M OVERALL ELECTRICAL WIRING DIAGRAM

cardiagn.com

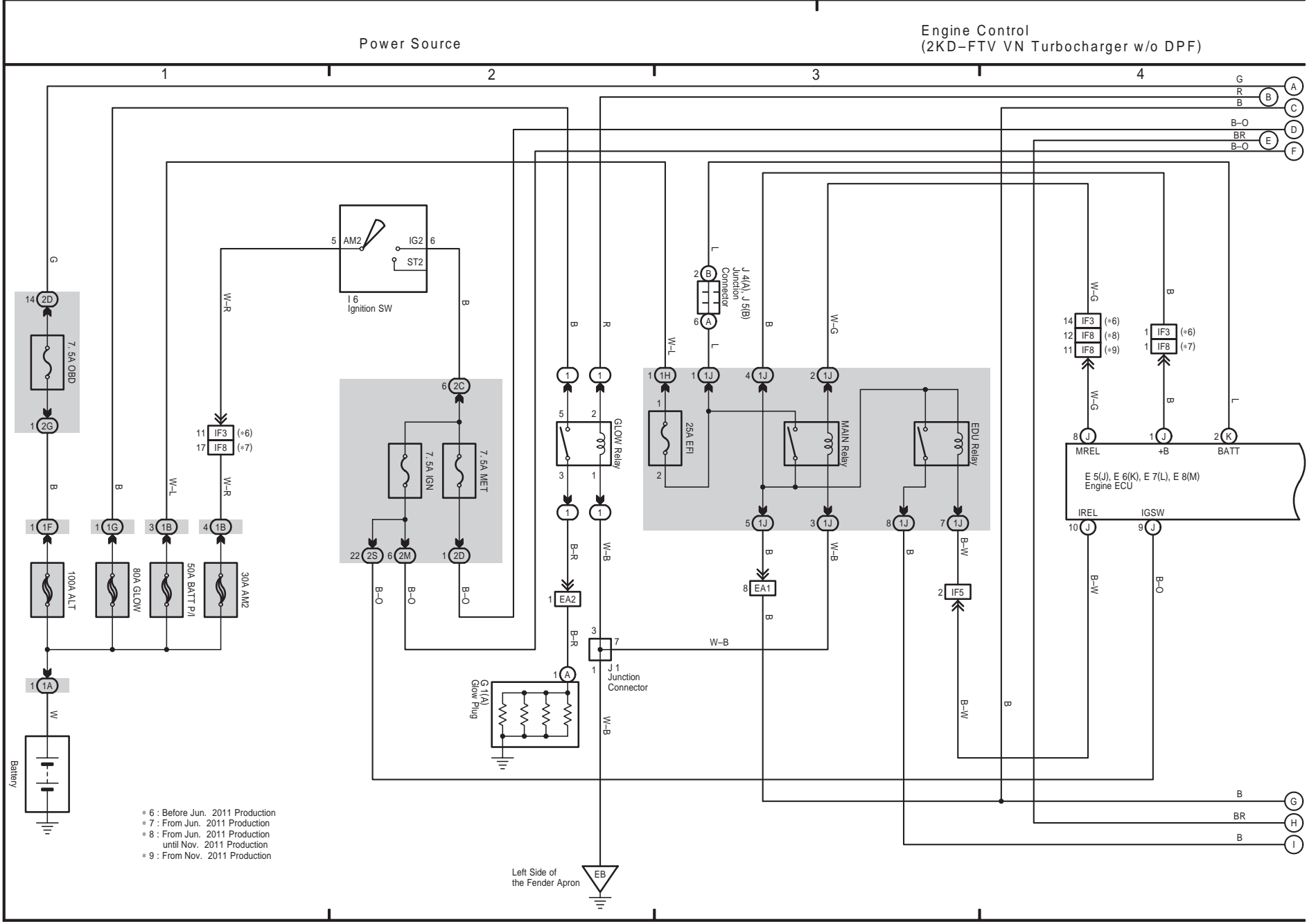

* 6 : Before Jun. 2011 Production
 * 7 : From Jun. 2011 Production
 * 8 : From Jun. 2011 Production until Nov. 2011 Production
 * 9 : From Nov. 2011 Production

Left Side of the Fender Apron
 EB

Engine Control (2KD-FTV VN Turbocharger w/o DPF)

* 6 : Before Jun. 2011 Production
 * 7 : From Jun. 2011 Production

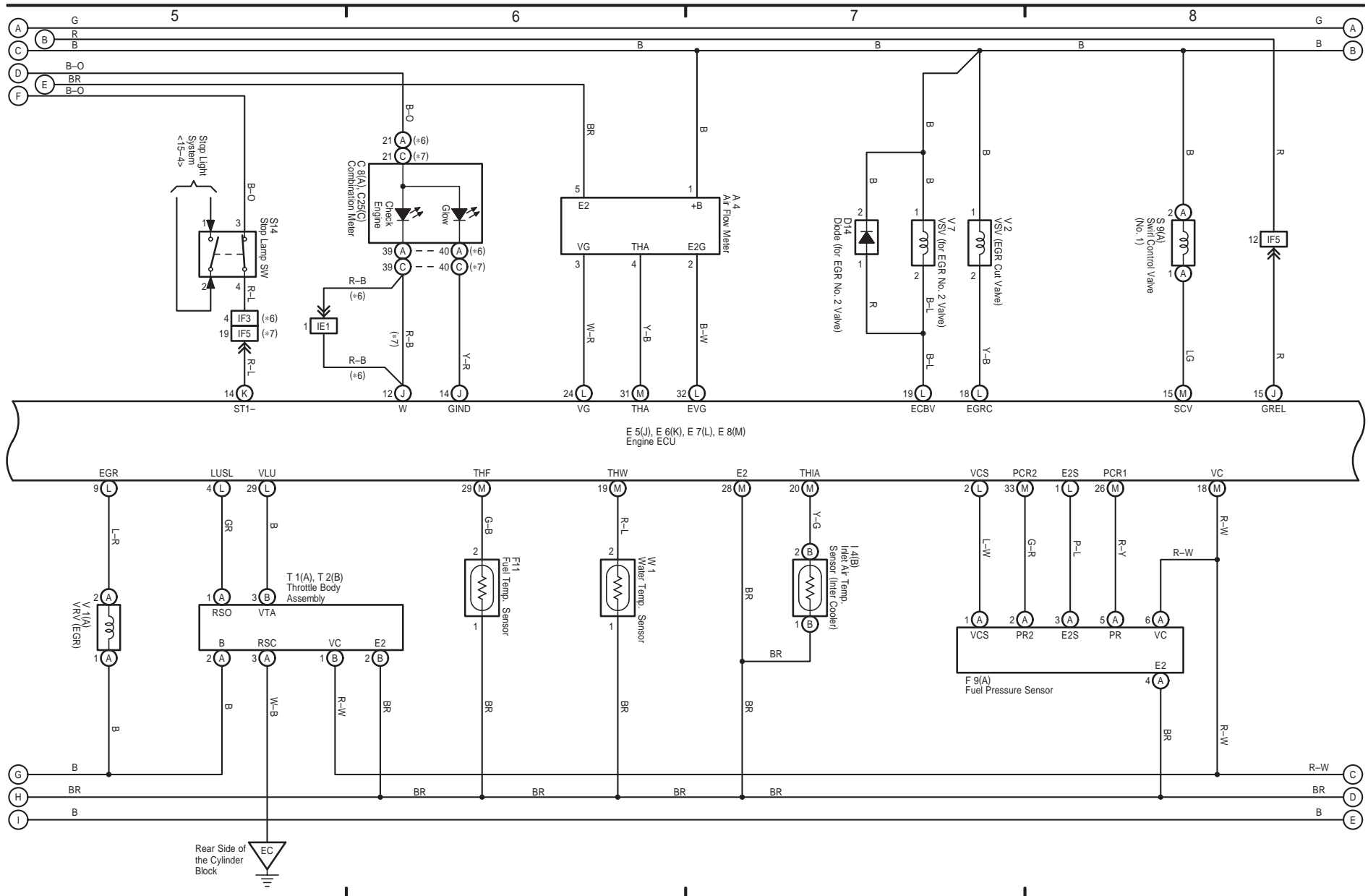

HILUX (EM1815E)

cardiagn.com

Engine Control (2KD-FTV VN Turbocharger w/o DPF)

- * 1 : Shielded
- * 2 : w/ PTC Heater w/o Manual A/C
- * 3 : w/ PTC Heater w/ Manual A/C
- * 4 : w/ Manual A/C
- * 5 : w/ Multi Display
- * 6 : Before Jun. 2011 Production
- * 7 : From Jun. 2011 Production
- * 11 : From Aug. 2012 Production
- * 12 : From Jun. 2011 Production until Aug. 2012 Production

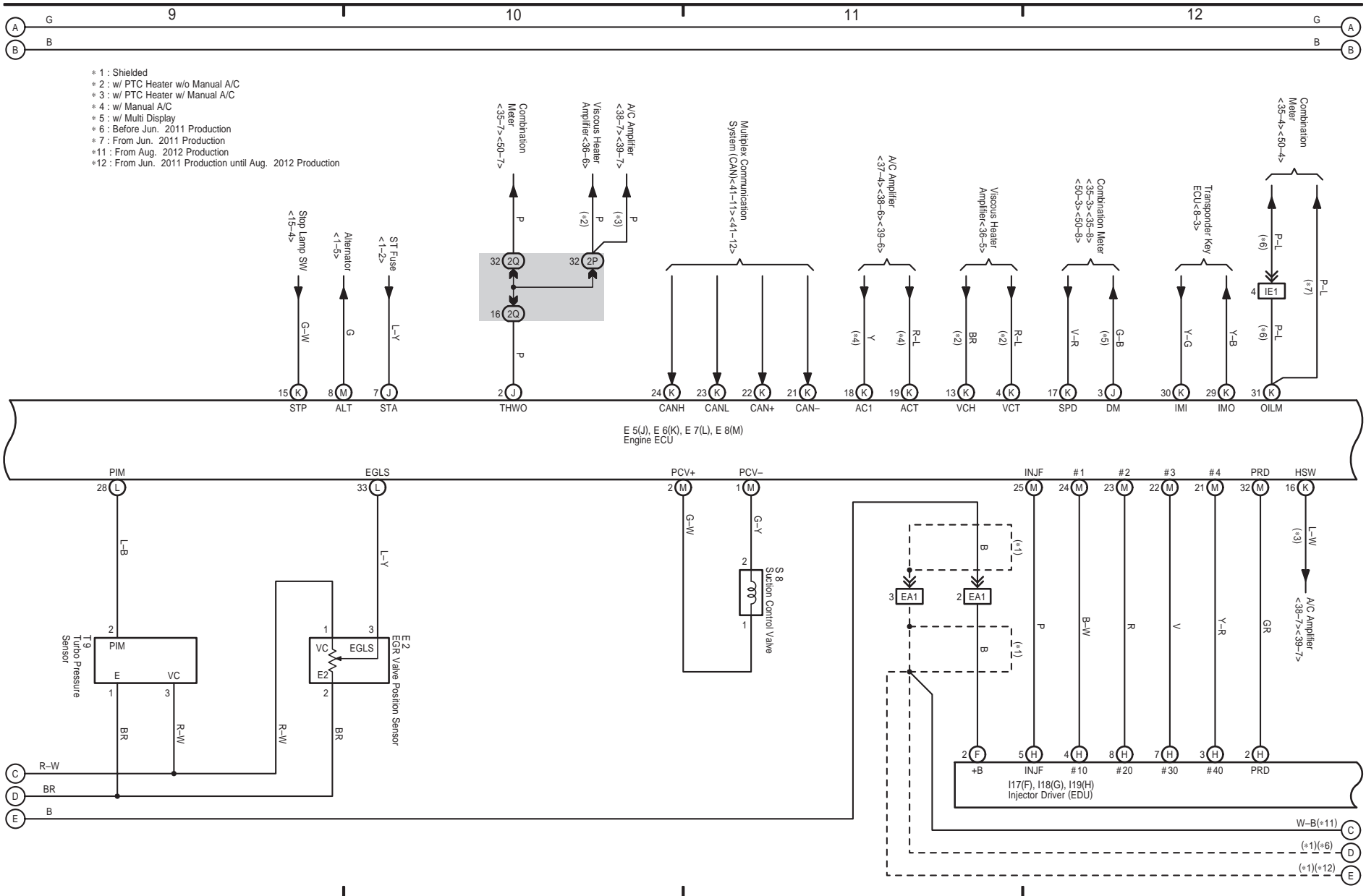

HILUX (EM1815E)

Engine Control (2KD-FTV VN Turbocharger w/o DPF)

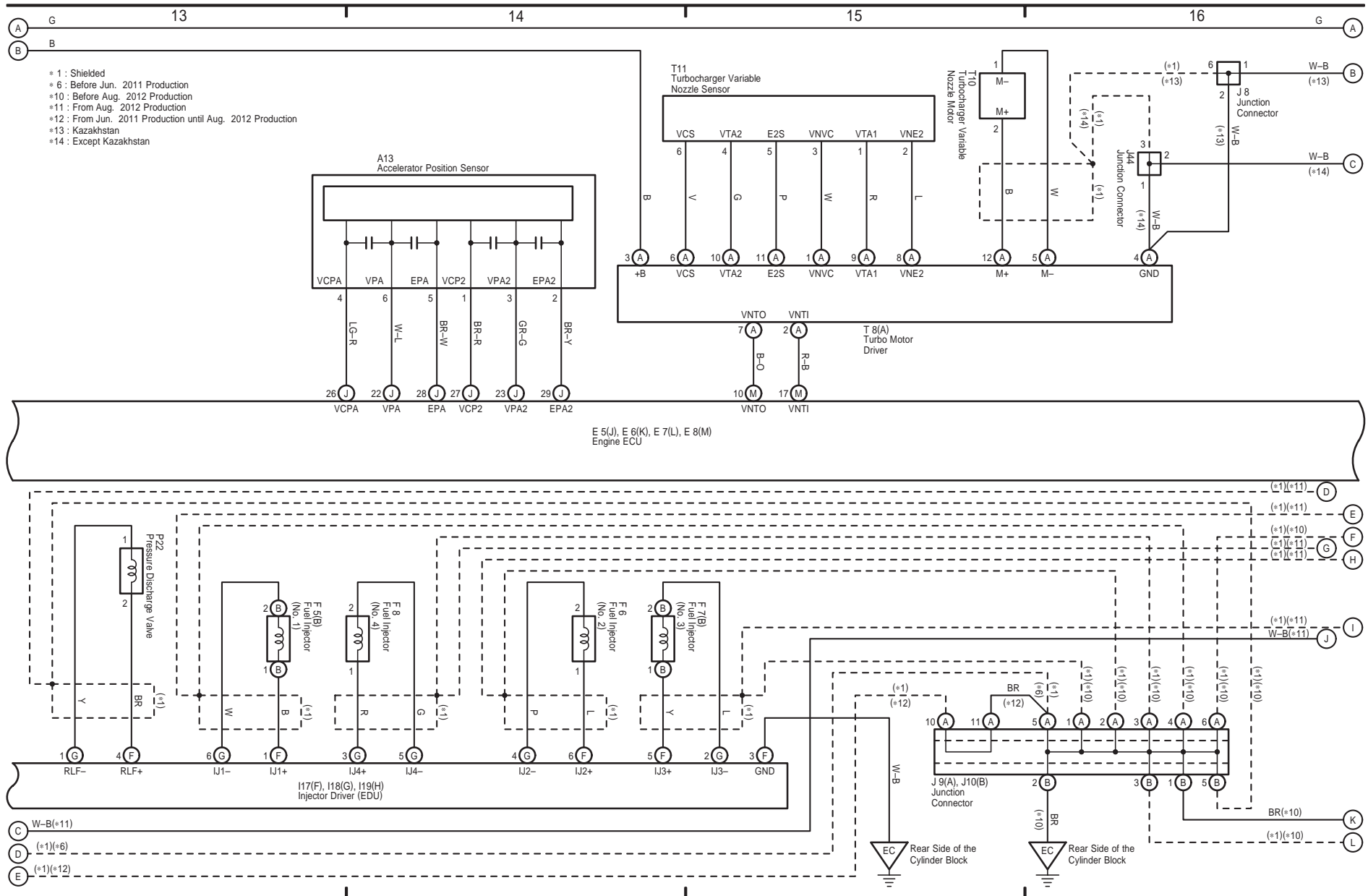

HILUX (EM1815E)

cardiagn.com

Engine Control (2KD-FTV VN Turbocharger w/o DPF)

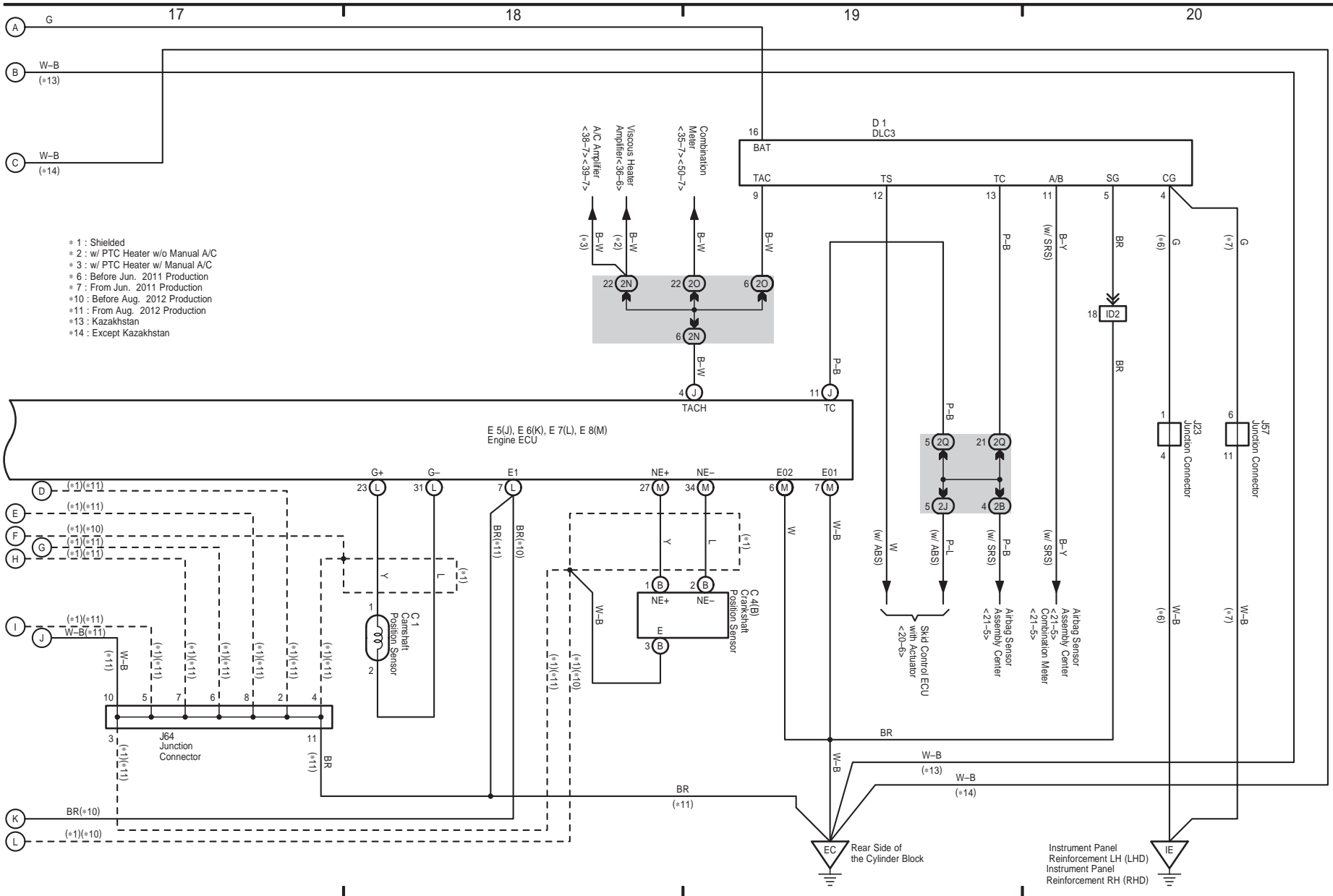

- * 1 : Shielded
- * 2 : w/ PTC Heater w/o Manual A/C
- * 3 : w/ PTC Heater w/ Manual A/C
- * 6 : Before Jun. 2011 Production
- * 7 : From Jun. 2011 Production
- * 10 : Before Aug. 2012 Production
- * 11 : From Aug. 2012 Production
- * 13 : Kazakhstan
- * 14 : Except Kazakhstan

HILUX (EM1815E)

Power Source

Power Seat (RHD)

* 1 : Before Aug. 2014 Production
 * 2 : From Aug. 2014 Production

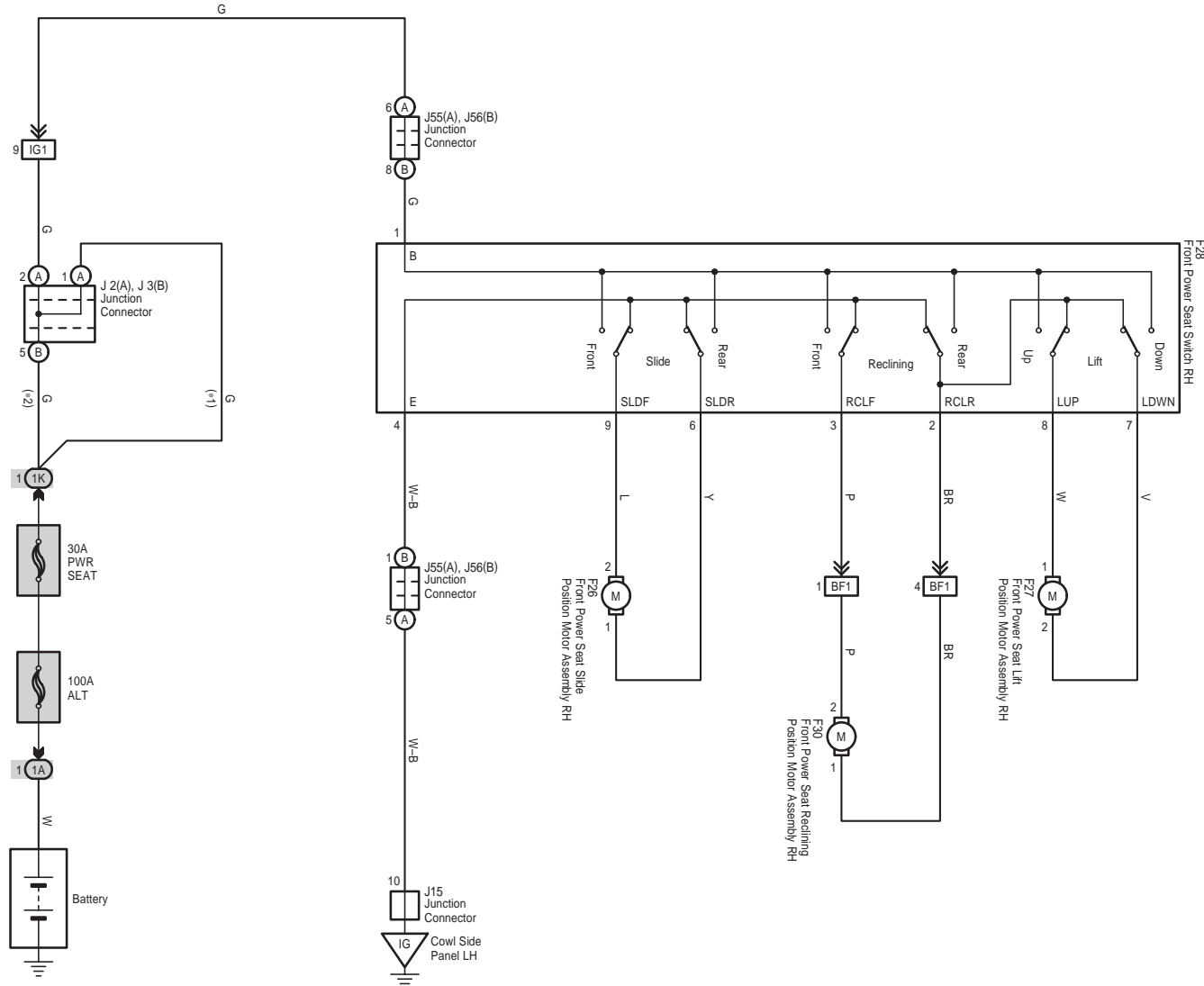

HILUX (EM1815E)

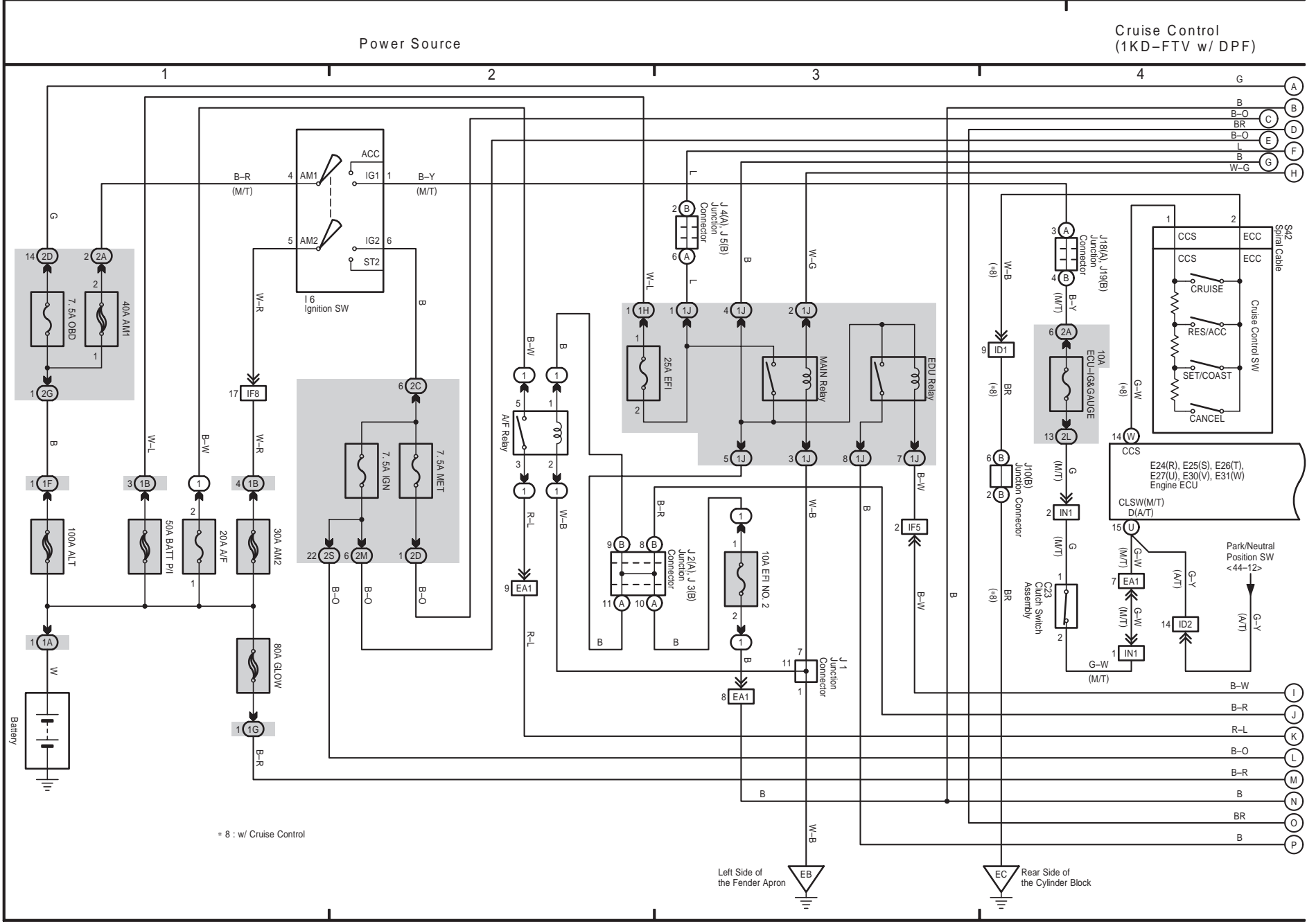

* 8 : w/ Cruise Control



Engine Control (1KD-FTV w/ DPF, 2KD-FTV VN Turbocharger w/ DPF)

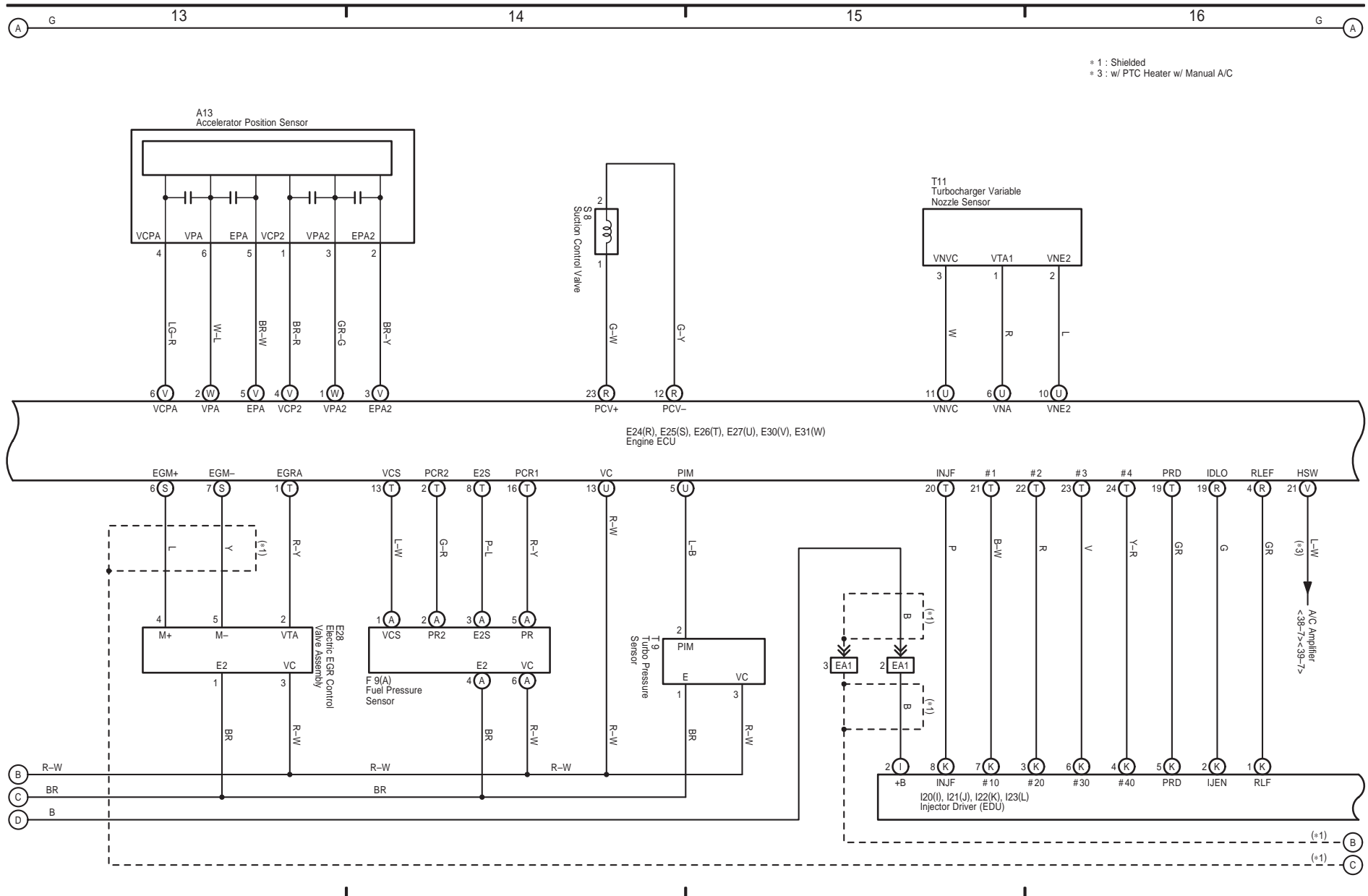

HILUX (EM1815E)

cardiagn.com

Engine Control (1KD-FTV w/ DPF, 2KD-FTV VN Turbocharger w/ DPF)



*1 : Shielded
*12 : Before Aug. 2012 Production
*13 : From Aug. 2012 Production

HILUX (EM1815E)

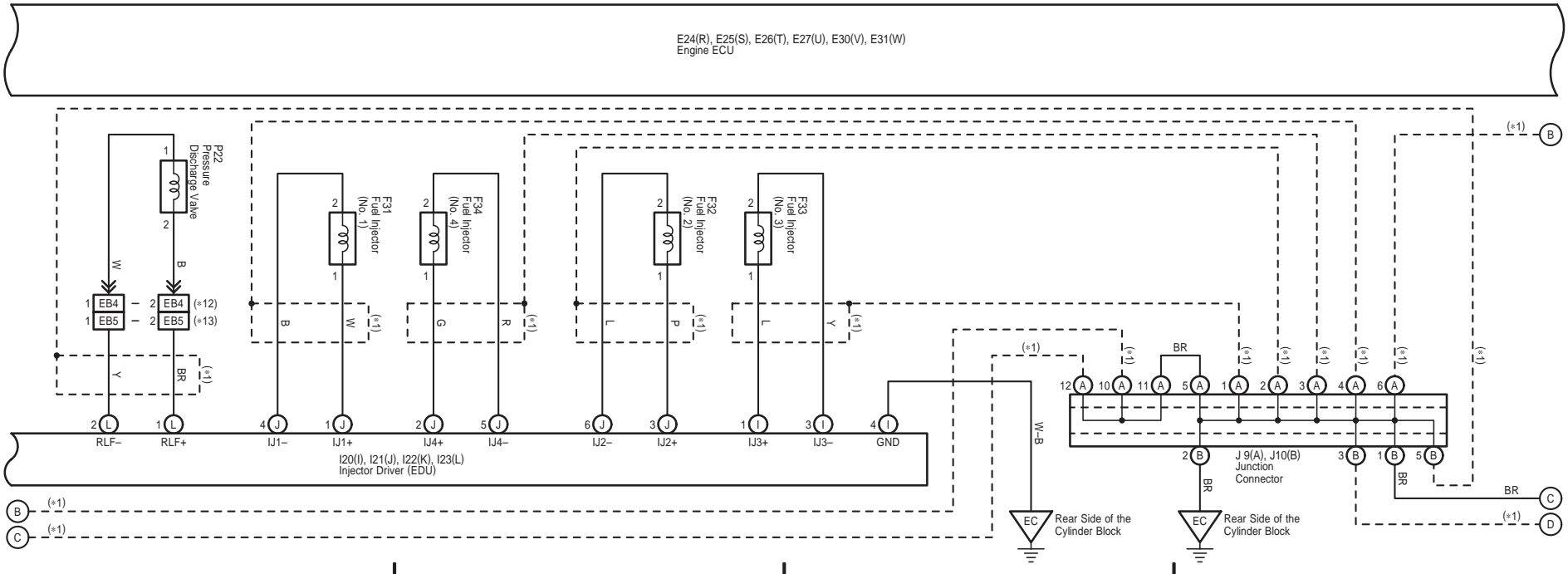

Engine Control (1KD-FTV w/ DPF, 2KD-FTV VN Turbocharger w/ DPF)

- * 1 : Shielded
- * 2 : w/ PTC Heater w/o Manual A/C
- * 3 : w/ PTC Heater w/ Manual A/C
- * 10 : Before Jun. 2011 Production
- * 11 : From Jun. 2011 Production

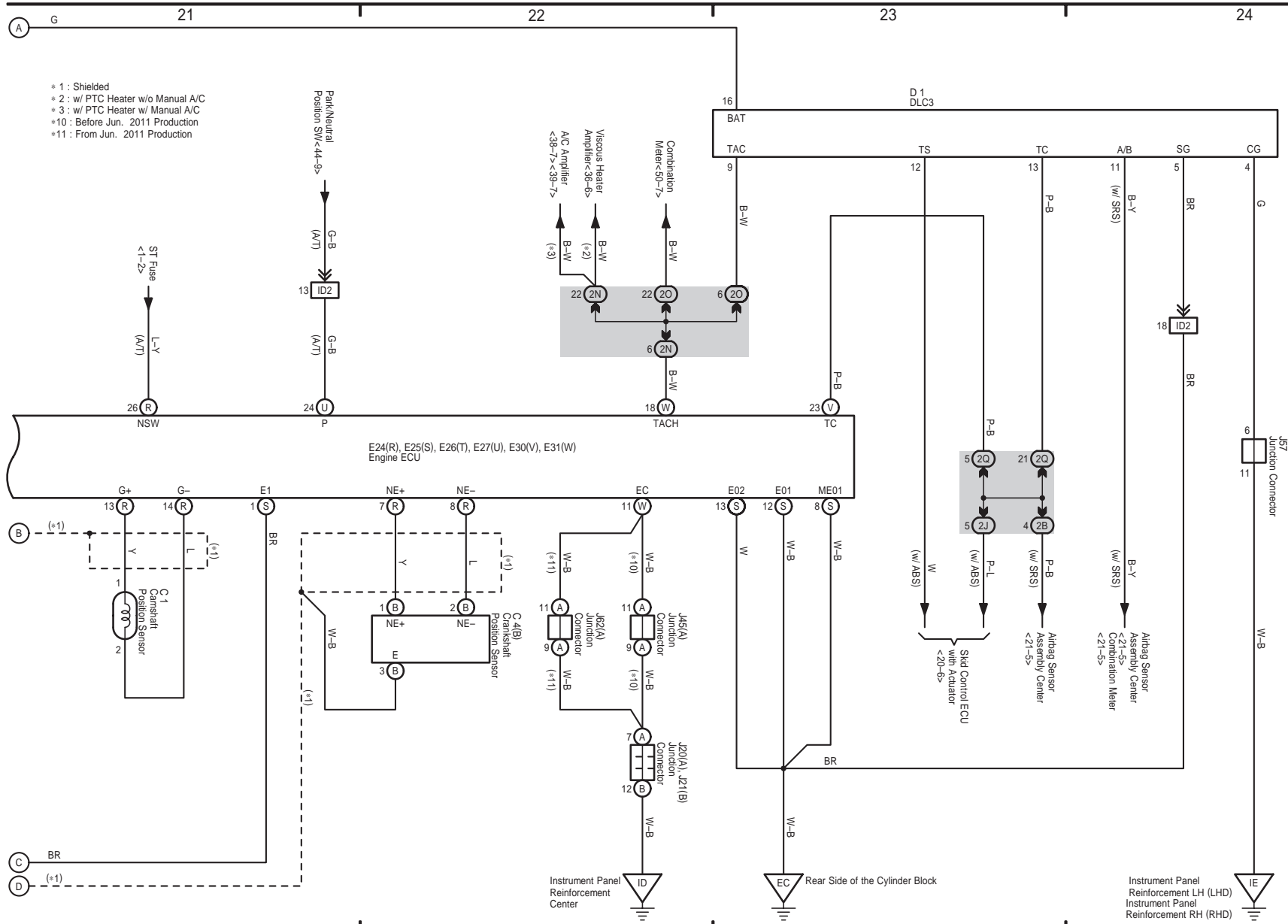

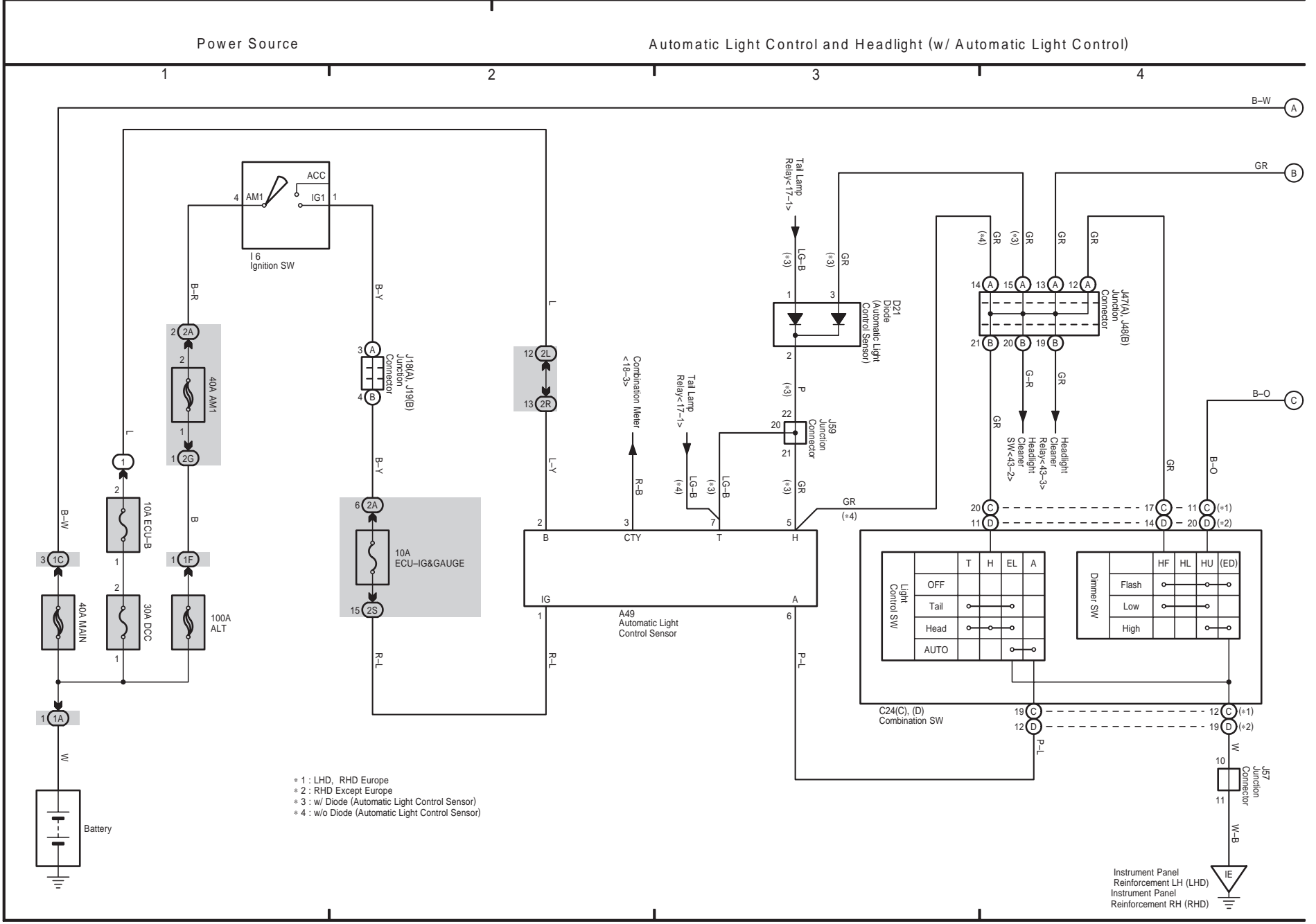

Instrument Panel
Reinforcement LH (LHD)
Instrument Panel
Reinforcement RH (RHD)

Automatic Light Control and Headlight (w/ Automatic Light Control)

* 5 : Before Nov. 2011 Production
 * 6 : From Nov. 2011 Production

HILUX (EM1815E)

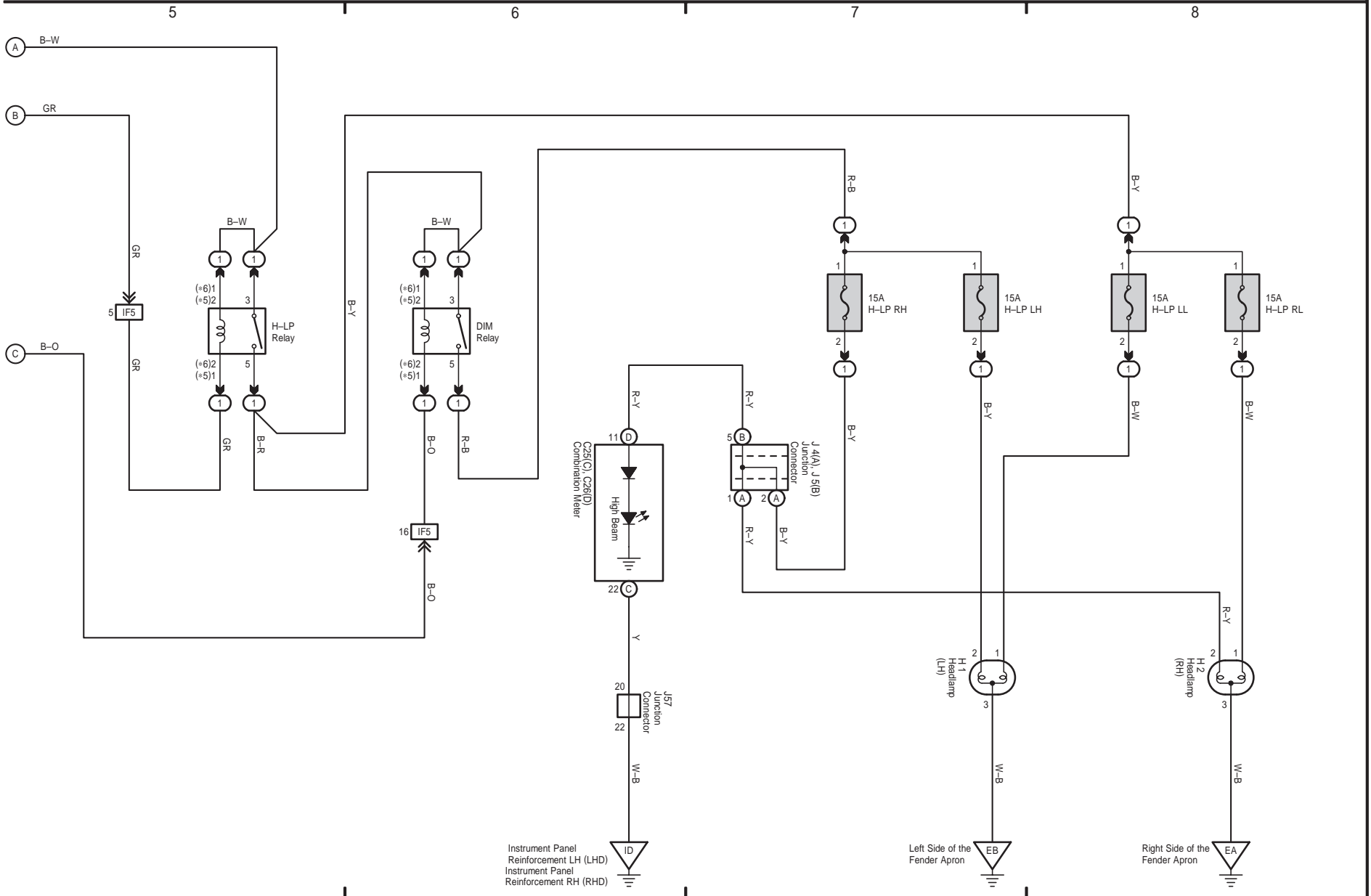

49 HILUX

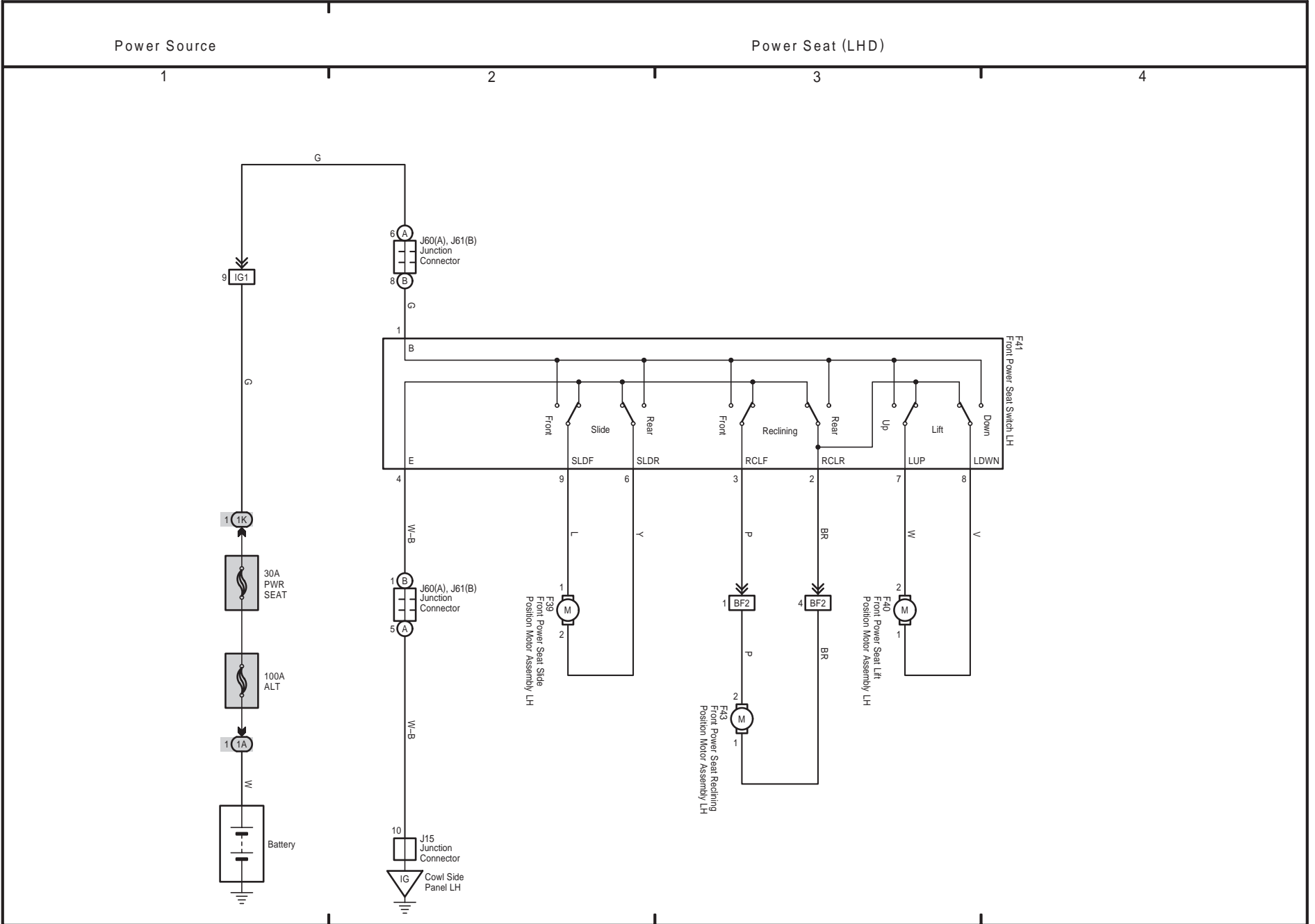

HILUX (EM1815E)

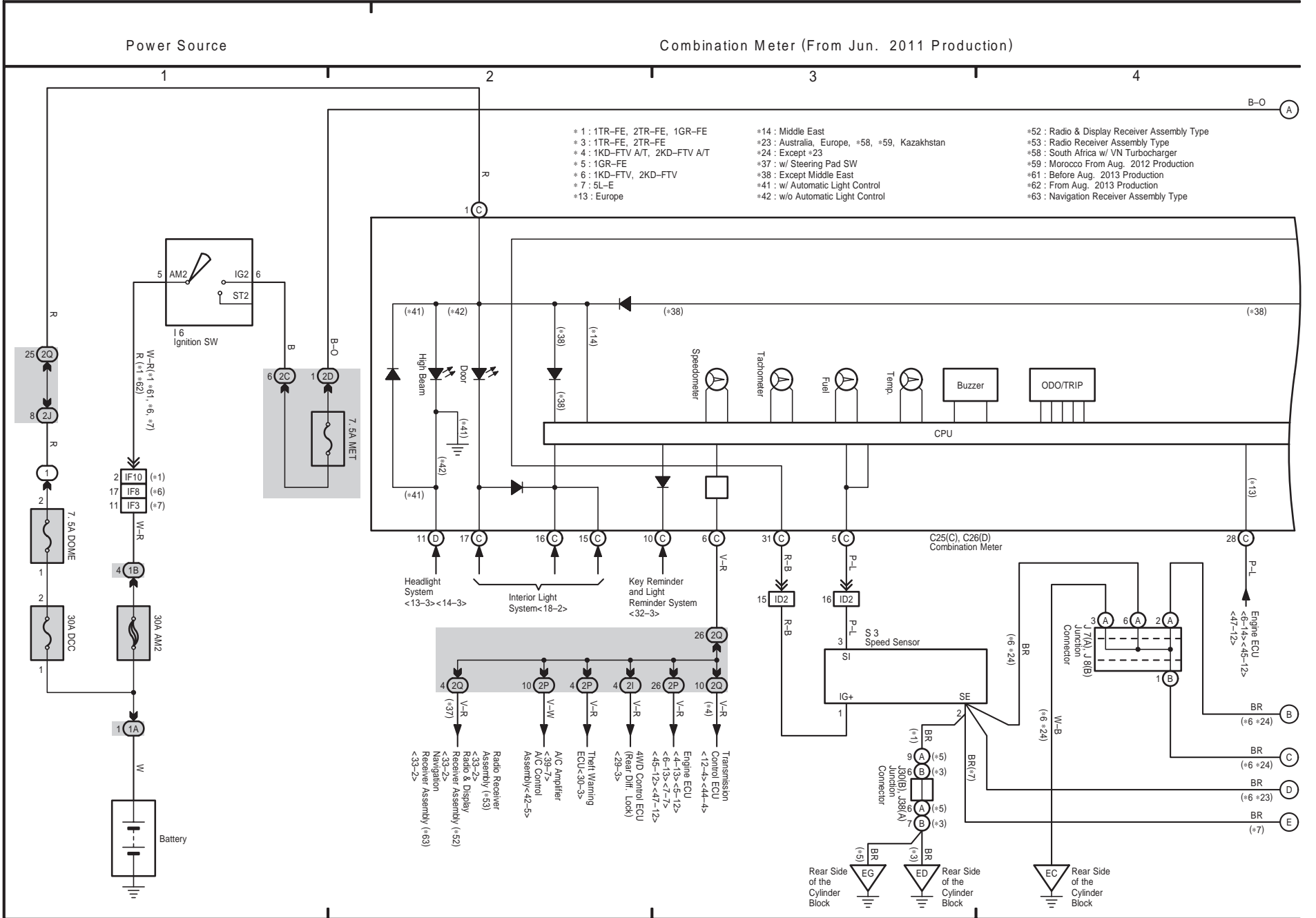

Combination Meter (From Jun. 2011 Production)

HILUX (EM1815E)

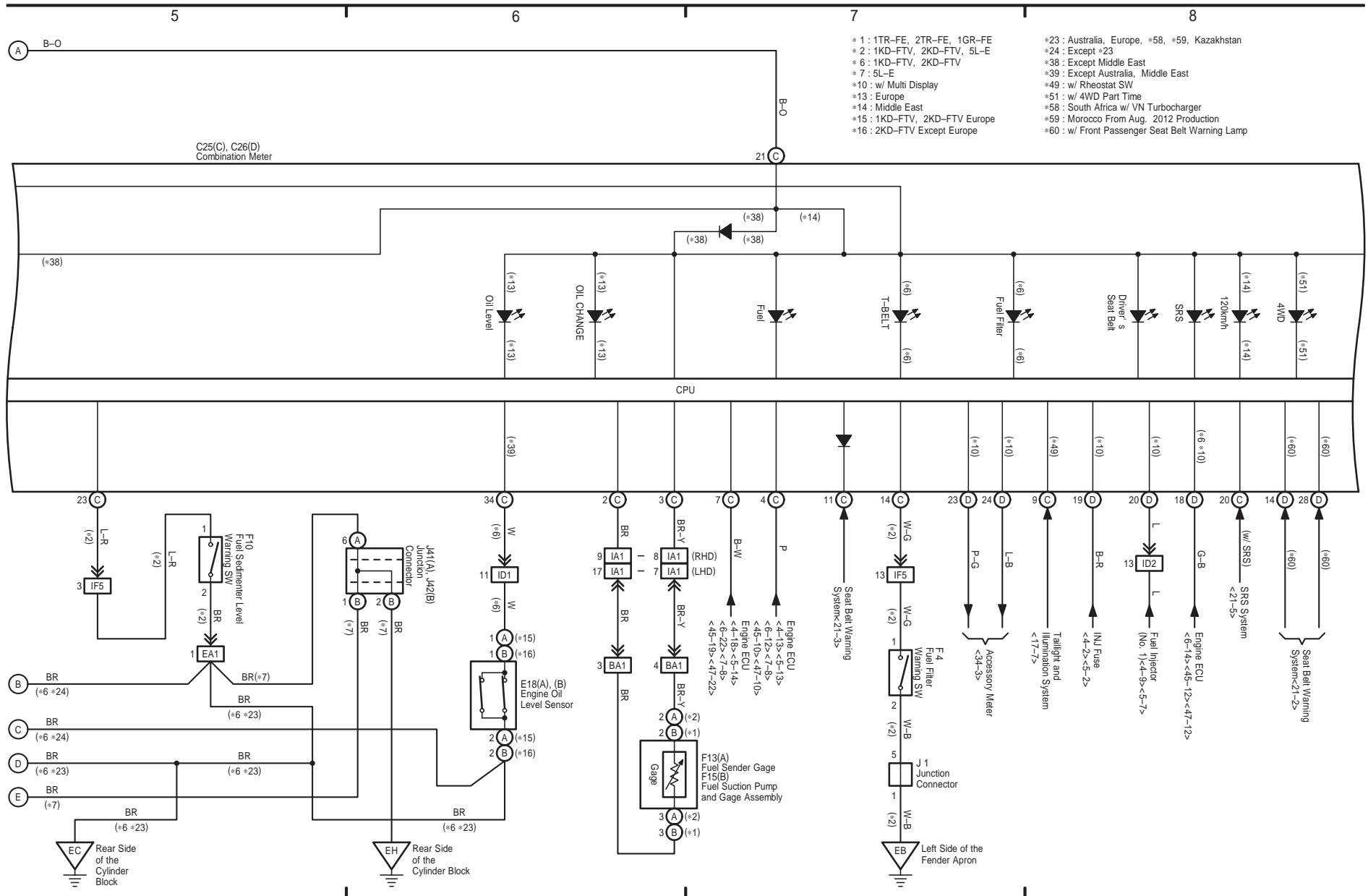

- *1 : 1TR-FE, 2TR-FE, 1GR-FE
- *2 : 1KD-FTV, 2KD-FTV, 5L-E
- *6 : 1KD-FTV, 2KD-FTV
- *7 : 5L-E
- *10 : w/ Multi Display
- *13 : Europe
- *14 : Middle East
- *15 : 1KD-FTV, 2KD-FTV Europe
- *16 : 2KD-FTV Except Europe
- *23 : Australia, Europe, *58, *59, Kazakhstan
- *24 : Except *23
- *38 : Except Middle East
- *39 : Except Australia, Middle East
- *49 : w/ Rheostat SW
- *51 : w/ 4WD Part Time
- *58 : South Africa w/ VN Turbocharger
- *59 : Morocco From Aug. 2012 Production
- *60 : w/ Front Passenger Seat Belt Warning Lamp

cardiagn.com

Combination Meter (From Jun. 2011 Production)

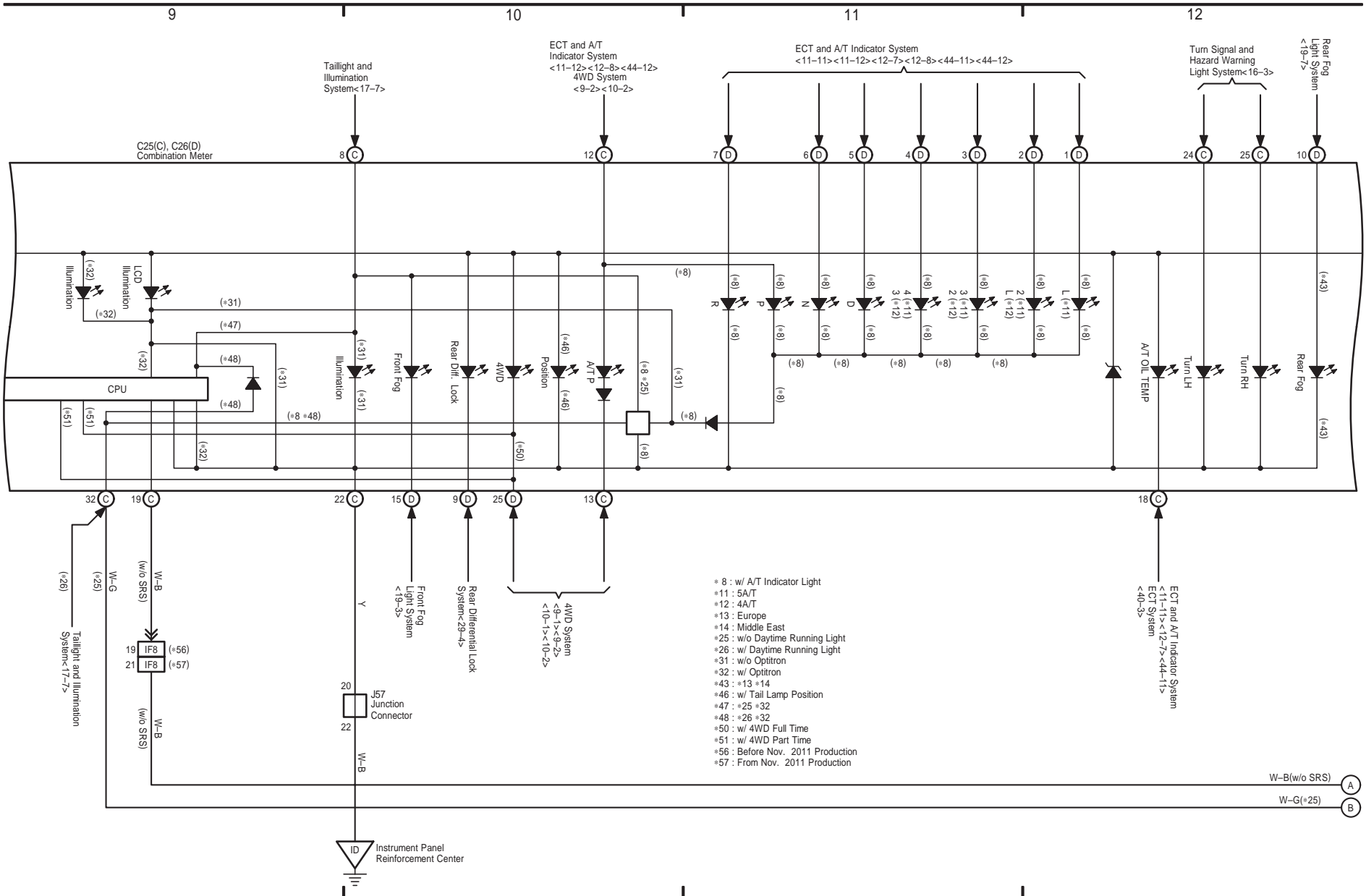

HILUX (EM1815E)

