

1982 DATSUN
NISSAN
STANZA
AUTOMATIC
TRANSAXLE

SERVICE MANUAL

FINLEY BROS.

DATSUN SALES & SERVICE
1312 NORTHCREST DRIVE
CRESCENT CITY, CALIF. 95531
PH. 464-6189



NISSAN STANZA

Model T11 Series

FOREWORD

This service manual has been prepared primarily for the purpose of assisting service personnel in providing effective service and maintenance of the 1982 NISSAN STANZA A/T.

This manual includes procedures for maintenance, adjustments, removal and installation, disassembly and assembly of components, and trouble-shooting.

All information, illustrations and specifications contained in this manual are based on the latest product information available at the time of publication. If your DATSUN model differs from the specifications contained in this manual, consult your NISSAN/DATSUN dealer for information.

The right is reserved to make changes in specifications and methods at any time without notice.

QUICK REFERENCE INDEX

GENERAL INFORMATION.....	GI
MAINTENANCE	MA
ENGINE MECHANICAL	EM
ENGINE LUBRICATION & COOLING SYSTEMS	LC
ENGINE FUEL	EF
EMISSION CONTROL SYSTEM	EC
ENGINE REMOVAL & INSTALLATION	ER
ENGINE CONTROL, FUEL & EXHAUST SYSTEMS	FE
AUTOMATIC TRANSAXLE	AT
FRONT AXLE & FRONT SUSPENSION	FA
REAR AXLE & REAR SUSPENSION	RA
BRAKE SYSTEM	BR
STEERING SYSTEM	ST
BODY	BF
HEATER & AIR CONDITIONER	HA
ELECTRICAL SYSTEM	EL

Black title on white ground sections:
Service procedures are not contained in this manual as they are the same as those for the M/T vehicle.

NISSAN MOTOR CO., LTD.

© 1981 NISSAN MOTOR CO., LTD.

Printed in Japan

Not to be reproduced in whole or in part without the prior written permission of Nissan Motor Company Ltd., Tokyo, Japan.

HOW TO USE THIS MANUAL

This Service Manual is designed as a guide for servicing NISSAN STANZA A/T. This manual includes service procedures specified for A/T vehicles. Those procedures which are the same as those for the M/T vehicle are not contained in this manual. Please use this manual in conjunction with the 1982 DATSUN NISSAN STANZA SERVICE MANUAL (Pub. No. SM2E-OT11U0).

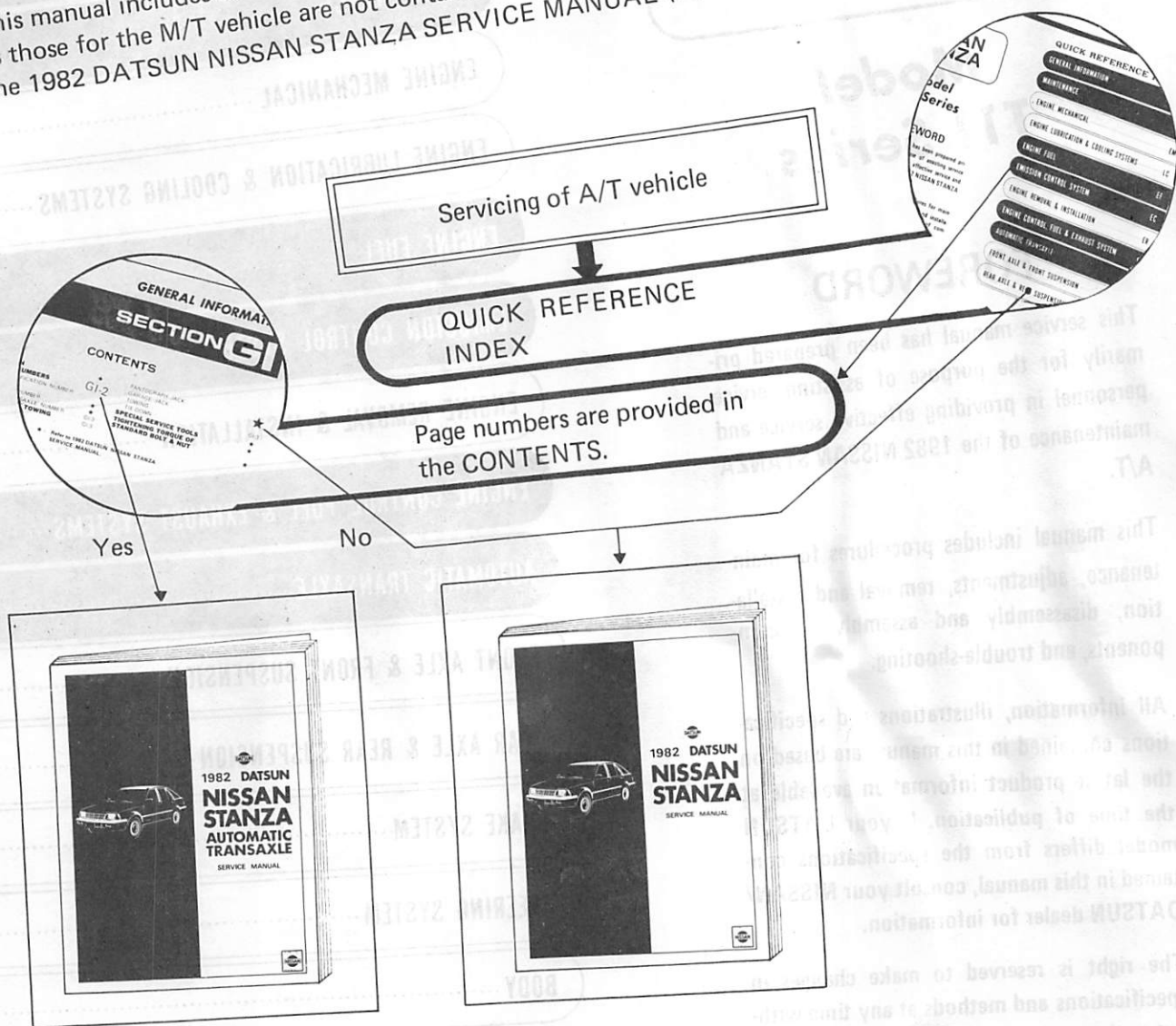

IMPORTANT SAFETY NOTICE

The proper performance of service is essential for both the safety of the mechanic and the efficient functioning of the vehicle.

The service methods in this Service Manual are described in such a manner that the service may be performed safely and accurately.

Special service tools have been designed to permit safe and proper performance of service. Be sure to use them.

Service varies with the procedures used, the skills of the mechanic and the tools and parts available. Accordingly, anyone using service procedures, tools or parts which are not specifically recommended by NISSAN must first completely satisfy himself that neither his safety nor the vehicle's safety will be jeopardized by the service method selected.

GENERAL INFORMATION

GI



CONTENTS

GENERAL VIEWS	★	PANTOGRAPH JACK	★
MODEL VARIATION	GI-2	GARAGE JACK	★
IDENTIFICATION NUMBERS	GI-3	TOWING	GI-3
VEHICLE IDENTIFICATION NUMBER		TIE-DOWN	★
(Chassis number)	★	SPECIAL SERVICE TOOLS	★
ENGINE SERIAL NUMBER	★	TIGHTENING TORQUE OF	
AUTOMATIC TRANSAXLE NUMBER	GI-3	STANDARD BOLT & NUT	★
LIFTING POINTS AND TOWING	GI-3		

★ : Refer to 1982 DATSUN NISSAN STANZA
SERVICE MANUAL.

MODEL VARIATION

Destination		Body	Model	Engine	Transaxle	Road wheel Size ... Offset mm (in)	Tire size
U.S.A	California	2-door Hatchback	KHLT11DAV	CA20	RN3F01A	5J-13 ... 45 (1.77) Steel (STD) Aluminum (opt) Spare wheel 4T-16 ... 35 (1.38)	165SR13 185/70SR13 Spare tire T125/70D16
		Sedan	KHLT11HAV				
		4-door Hatchback	FHLT11DAV				
		Sedan	FHLT11HAV				
	Non-California	2-door Hatchback	KHLT11DAU				
		Sedan	KHLT11HAU				
		4-door Hatchback	FHLT11DAU				
		Sedan	FHLT11HAU				
Canada	2-door	Hatchback	KHLT11DAN				
		Sedan	KHLT11HAN				
	4-door	Hatchback	FHLT11DAN				
		Sedan	FHLT11HAN				

Prefix and suffix designations:

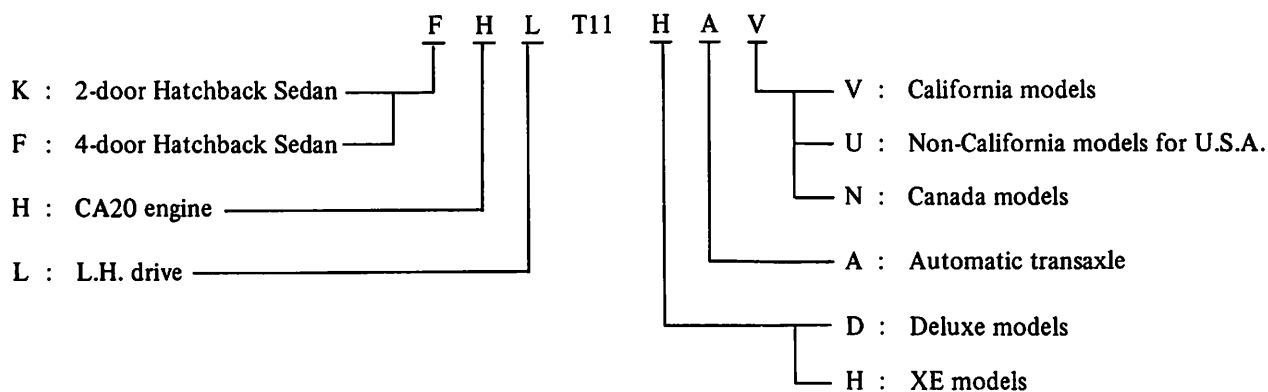

IDENTIFICATION NUMBERS

AUTOMATIC TRANSAXLE NUMBER

The automatic transaxle serial number label is attached on the upper face of the transmission case.

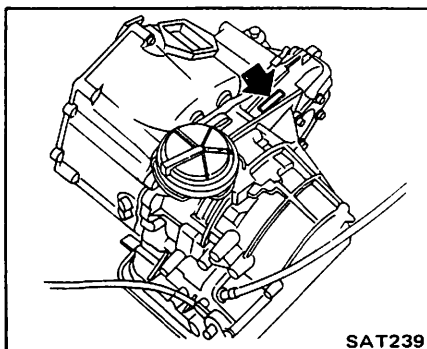

SAT239

LIFTING POINTS AND TOWING

TOWING

CAUTION:

- a. It is necessary to use proper towing equipment to avoid possible damage to the vehicle during a towing operation.
Towing is in accordance with Towing Procedure Manual at dealer side.
- b. All applicable State or Provincial (in Canada) laws and local laws regarding the towing operation must be obeyed.
- c. Before towing, make sure that the transaxle, steering system and power train are in good order. If any unit is damaged, a dolly must be used.
- d. If the transaxle is inoperative, tow the vehicle with the front wheels off the ground.
- e. When the vehicle is towed with its front wheels on the ground, secure the steering wheel in a straight ahead position with the ignition key turned in "OFF" position.
- f. Release the parking brake and set the gearshift lever in "Neutral" position before starting to tow the vehicle.
- g. When towing an automatic transaxle model, try to restrict towing speed below 30 km/h (20 MPH) and towing distance less than 30 km (20 miles).
- h. Never tow an automatic transaxle model with rear wheels raised (with front wheels on ground) as this may cause serious damage to the vehicle. If it is necessary to tow it with rear wheels raised, always use a towing dolly under the front wheels.
- i. Do not apply force to the towing hook in a lateral direction. Keep the tow rope or similar device straight ahead, in line with the vehicle.

MAINTENANCE

MA

CONTENTS

MAINTENANCE SCHEDULE	MA-2	AUTOMATIC TRANSAXLE	MA-7
LUBRICATION CHART	MA-4	FRONT AXLE AND	
RECOMMENDED FUEL AND		FRONT SUSPENSION	★
LUBRICANTS	MA-5	REAR AXLE AND	
FUEL	MA-5	REAR SUSPENSION	★
LUBRICANTS	MA-5	BRAKE SYSTEM	★
SAE VISCOSITY NUMBER	MA-5	WHEEL AND TIRE	★
APPROXIMATE REFILL		STEERING SYSTEM	★
CAPACITIES	MA-5	BODY	★
ENGINE MAINTENANCE	MA-6	HEATER AND AIR CONDITIONER	★
BEFORE ENGINE START	★	SERVICE DATA AND	
AFTER ENGINE WARM-UP	MA-6	SPECIFICATIONS (S.D.S.)	MA-7
CHASSIS AND BODY		ENGINE MAINTENANCE	MA-7
MAINTENANCE	MA-7	CHASSIS AND BODY	
ENGINE CONTROL, FUEL		MAINTENANCE	★
AND EXHAUST SYSTEMS	★		

★: Refer to 1982 DATSUN NISSAN STANZA SERVICE MANUAL.

The following tables list the periodic maintenance servicing required to ensure good emission control performance, good engine performance and good mechanical condition in DATSUN.

The first 1,600 km (1,000 miles) service is one of the most important services required to ensure the maximum emission control performance and optimum engine condition.

Periodic maintenance beyond the last period shown in the tables requires similar maintenance.

MAINTENANCE OPERATION	Kilometers x 1,000 (Miles x 1,000) Months	MAINTENANCE INTERVAL							Reference page
		1.6	12	24	36	48	60	72	
		(1)	(7.5)	(15)	(22.5)	(30)	(37.5)	(45)	
Periodic maintenance should be performed at number of kilometers, miles or months, whichever comes first.		-	6	12	18	24	30	36	

EMISSION CONTROL MAINTENANCE

Drive belts						1			Refer to 1982 DATSUN NISSAN STANZA Service Manual.
Carburetor air cleaner filter	See NOTE: (2)					R			
Air induction valve filter	See NOTE: (2)					R			
*Positive Crankcase Ventilation (P.C.V.) filter	See NOTE: (3)								
*Vapor lines						I			
*Fuel lines (hoses, piping, connections, etc.)						I			
*Fuel filter	See NOTE: (3)								
Engine coolant						R			
Engine oil & oil filter	See NOTE: (1)		R	R	R	R	R	R	
Spark plugs						R			
*Ignition wires						I			
Intake & Exhaust valve clearance		A		A		A		A	
Carburetor idle rpm		I		I*		I*		I*	
*Automatic temperature control air cleaner						I			

- NOTE:**
- (1) If vehicle is operated under severe conditions: short distance driving, extensive idling or driving in dusty conditions, change engine oil every 5,000 km (3,000 miles) or 3 months, whichever comes first.
 - (2) More frequent maintenance is required under dusty driving conditions.
 - (3) If vehicle is operated under extremely adverse weather conditions or in areas where ambient temperatures are either extremely low or extremely high, the filters might become clogged. In such an event, replace them immediately.
 - (4) Maintenance items and intervals with "*" are recommended by NISSAN MOTOR CO., LTD. Other maintenance items and intervals are required.

Abbreviations: A = Adjust

R = Replace

I = Inspect, correct, replace if necessary.

MAINTENANCE SCHEDULE

The following Maintenance Schedule tables apply to all T11 models either with A/T or M/T.

MAINTENANCE OPERATION	Periodic maintenance should be performed at number of kilometers, miles or months, whichever comes first.	MAINTENANCE INTERVAL							Reference page	
		Kilometers x 1,000	1.6	12	24	36	48	60		72
		(Miles x 1,000)	(1)	(7.5)	(15)	(22.5)	(30)	(37.5)		(45)
		Months	-	6	12	18	24	30		36

UNDERHOOD MAINTENANCE

Brake & automatic transaxle fluid level & leaks	See NOTE: (1)			I		I		I	MA-7
Brake fluid				R		R		R	Refer to 1982 DATSUN NISSAN STANZA Service Manual.
Brake booster vacuum hoses, connection & check valve						I			
Air conditioning system hoses, connection & refrigerant leaks						I			
Power steering fluid & lines				I		I		I	

UNDER VEHICLE MAINTENANCE

Brake, fuel & exhaust systems for proper (attachment, leaks, cracks, chafing, abrasion, deterioration, etc.)				I		I		I	Refer to 1982 DATSUN NISSAN STANZA Service Manual.
Manual transaxle gear oil	See NOTE: (1)			I		I		I	
Steering gear box & linkage, suspension parts for damaged, loose & missing parts	See NOTE: (1)	I		I		I	I	I	
Underbody (flush & clean every 12 months)				I		I		I	

OUTSIDE AND INSIDE MAINTENANCE

Rotate wheel position & inspect wheel balance & wheel alignment				I		I		I	Refer to 1982 DATSUN NISSAN STANZA Service Manual.
Disc brake pads or brake drums, linings & other brake components for wear, deterioration & leaks	See NOTE: (3)			I		I		I	
Front wheel bearing grease						I			
Locks, hinges & hood latch	See NOTE: (3)			L		L		L	
Seat belts, buckles, retractors, anchors & adjuster				I		I		I	
Foot brake, parking brake & clutch for stroke, free play & operation				I		I		I	

- NOTE:** (1) When towing a trailer, change oil in transaxle every 48,000 km (30,000 miles) or 24 months, whichever comes first.
(2) Steering linkage & front suspension ball joint inspection should be performed every 96,000 km (60,000 miles) or 4 years, whichever comes first.
(3) If vehicle is operated in areas using road salt or other corrosive materials, inspect every 5,000 km (3,000 miles) or 3 months, whichever comes first.

The above charts show the normal maintenance schedule. Depending upon weather and atmospheric conditions, varying road surfaces, individual driving habits and vehicle usage, additional or more frequent maintenance may be required.

Abbreviations: L = Lubricate R = Replace
I = Inspect, correct, replace if necessary

LUBRICATION CHART

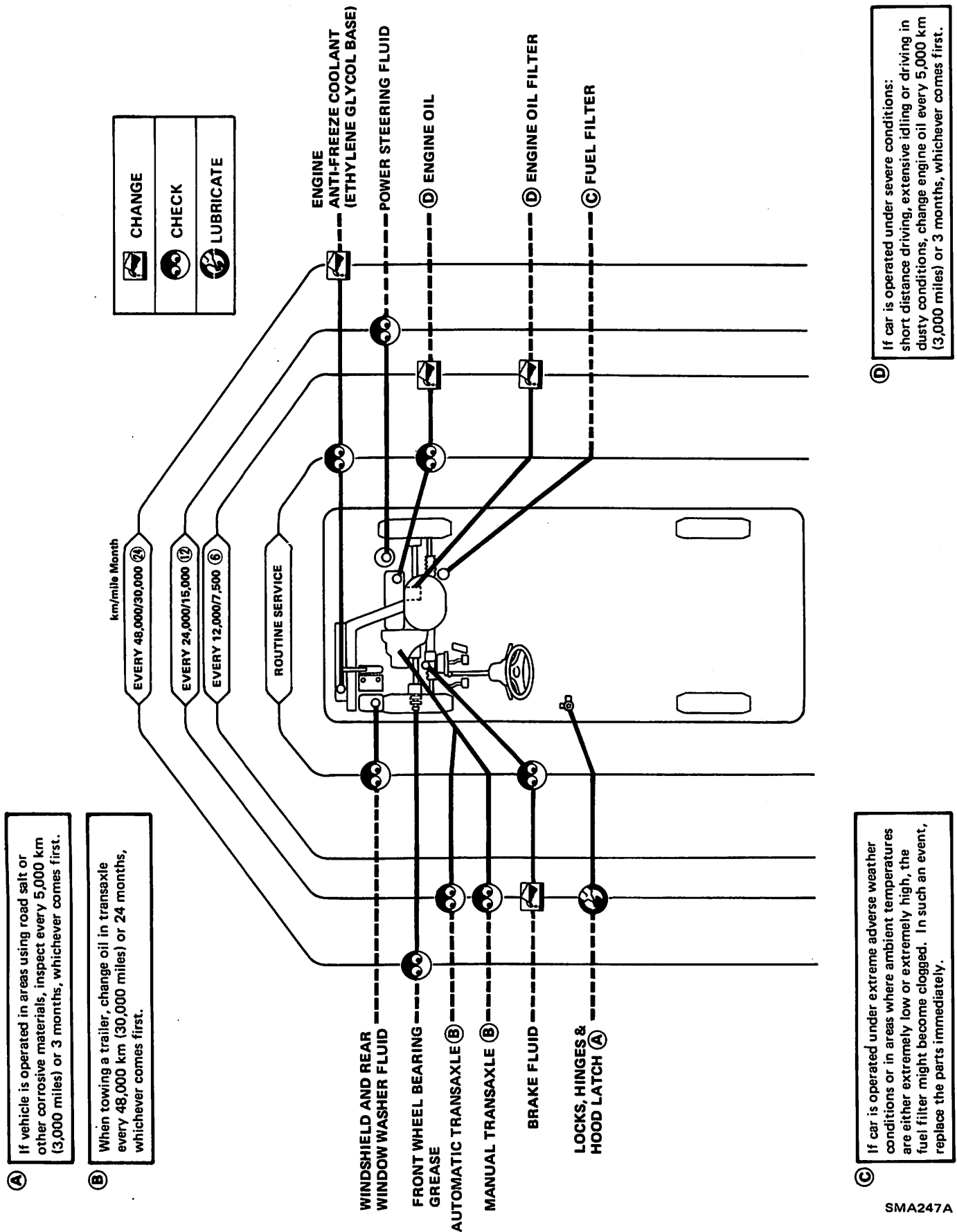

RECOMMENDED FUEL AND LUBRICANTS

FUEL

Gasoline		Gasoline octane number (minimum)	
		RON	(R + M)/2
All models	Unleaded	91	87

The fuel filler opening is designed for use with an unleaded fuel gun [nozzle diameter less than 21.3 mm (0.84 in)] only.

LUBRICANTS

Lubricant	Specifications	Remarks
Gasoline engine oil	API SE	Further details, refer to recommended SAE viscosity chart.
Automatic transaxle gear oil	Type DEXRON	—
Power steering fluid	Type DEXRON	—
Multi-purpose grease	NLGI No. 2	Lithium soap base
Brake fluid	DOT 3	US FMVSS No. 116
Anti-freeze	—	Ethylene glycol base

SAE VISCOSITY NUMBER

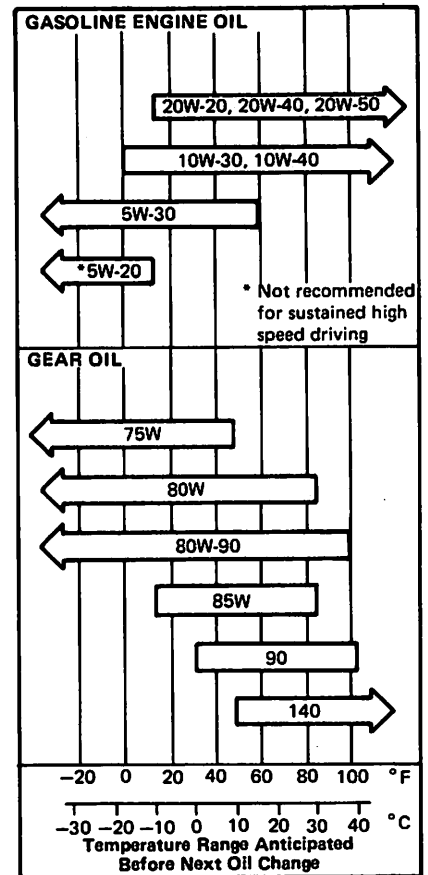

APPROXIMATE REFILL CAPACITIES

		Liter	US measure	Imp measure
Fuel tank		54	14-1/4 gal	11-7/8 gal
Coolant	With heater	7.3	7-3/4 qt	6-3/8 qt
	Without heater	6.5	6-7/8 qt	5-3/4 qt
Engine	With oil filter	3.9	4-1/8 qt	3-3/8 qt
	Without oil filter	3.5	3-3/4 qt	3-1/8 qt
Transaxle	Automatic	6.0	6-3/8 qt	5-1/4 qt
Power steering system		1.0	1-1/8 qt	7/8 qt
Air conditioning system	Compressor oil	0.15	5.1 fl oz	5.3 fl oz
	Refrigerant	0.8 - 1.0 kg	1.8 - 2.2 lb	1.8 - 2.2 lb

ENGINE MAINTENANCE

AFTER ENGINE WARM-UP

CHECKING IDLE RPM

Preparation

1. On air conditioner equipped models, checks should be carried out while the air conditioner is "OFF".
2. On automatic transmission equipped models, checks should be carried out while shift lever is in "D" position.
3. The electric components (lights, heater, all accessories, etc.) should be off because idle speed control system is not operating.

(Refer to EF section.)

WARNING:

- a. When selector lever is shifted to "D" position, apply parking brake and block both front and rear wheels with chocks.
- b. When racing engine on automatic transmission equipped models, make sure that shift lever is in "N" or "P" position and depress brake pedal to prevent forward surge of car.
- c. After the adjustment has been made, shift the lever to the "N" or "P" position and remove wheel chocks.

Maintenance procedure

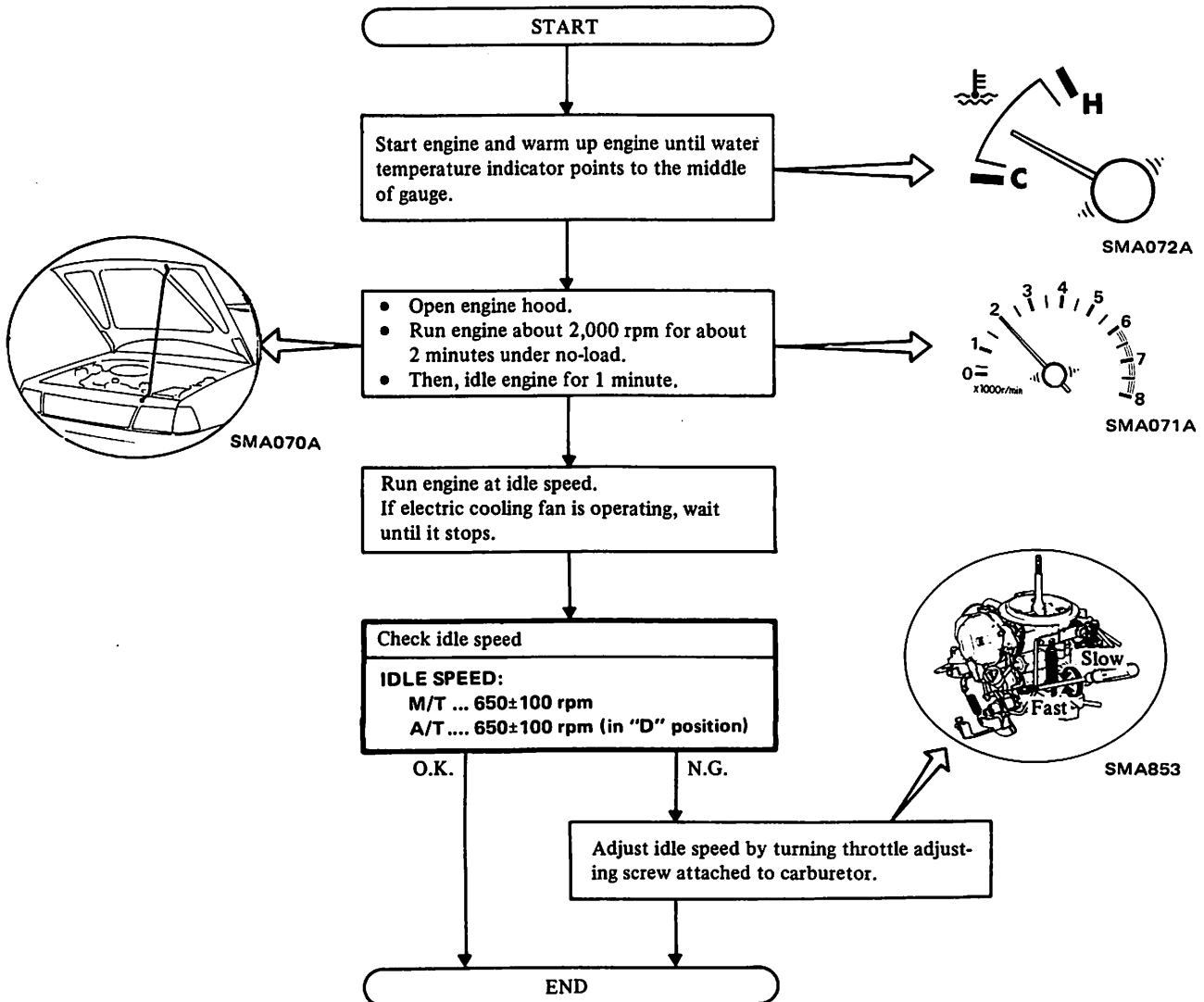

CHASSIS AND BODY MAINTENANCE

AUTOMATIC TRANSAXLE

CHECKING AUTOMATIC TRANSAXLE FLUID LEVEL

1. Check under following conditions.
 - (1) Place selector lever in "P" (PARK) position and idle engine.
 - (2) Maintain fluid temperature at 50 to 80°C (122 to 176°F).
2. Add oil, if necessary.

Use only automatic transmission fluid having "DEXRON" identifications in F01A automatic transaxle.

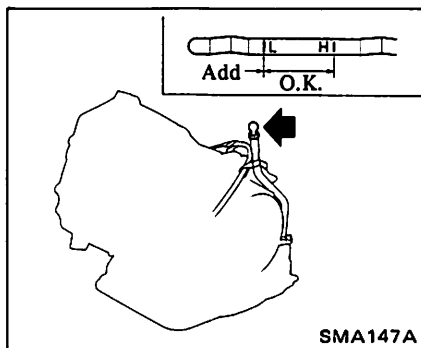

SMA147A

CHECKING AUTOMATIC TRANSAXLE FLUID CONDITION

Check fluid for contamination to determine condition of automatic transaxle. If fluid is very dark or smells burned, the frictional material (clutches, band, etc.) may need replacement.

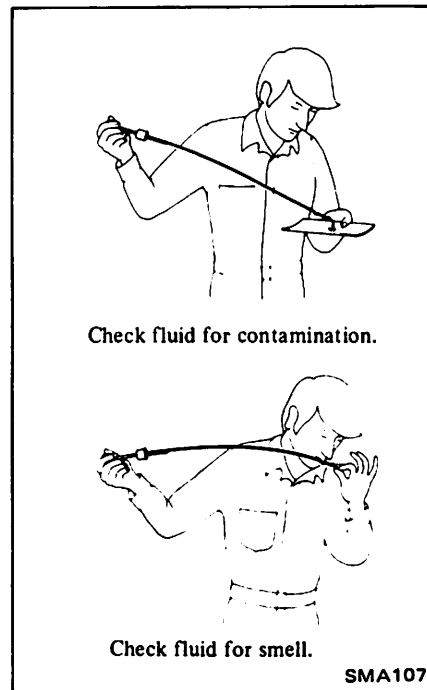

Check fluid for contamination.

Check fluid for smell.

SMA107

SERVICE DATA AND SPECIFICATIONS (S.D.S.)

ENGINE MAINTENANCE

INSPECTION AND ADJUSTMENT

Ignition and fuel system

Ignition timing, idle speed and idle "CO"%

Unit: degree/rpm

Automatic transmission* (in "D" position)	0±2° B.T.D.C./650±100
"CO"% at idle speed (No air)	Idle mixture screw is preset and sealed at factory

* Ignition timing should be checked with distributor vacuum hose disconnected and plugged up.

ENGINE FUEL

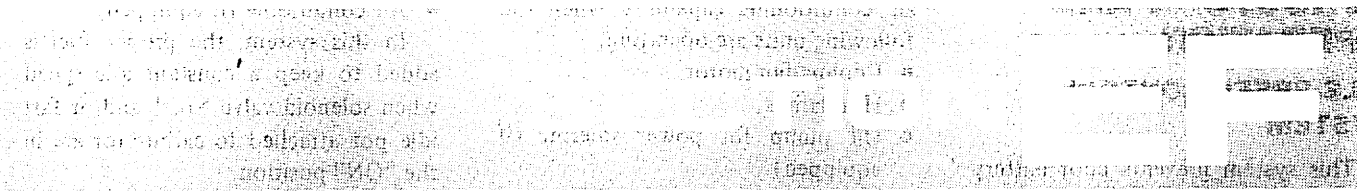

CONTENTS

AUTOMATIC TEMPERATURE CONTROL (A.T.C.) AIR CLEANER	★	CARBURETOR IDLE-R.P.M. AND MIXTURE RATIO	EF-3
IDLE COMPENSATOR	★	IDLE SPEED CONTROL	EF-5
FUEL PUMP	★	DASH POT	EF-6
CARBURETOR	EF-2	SERVICE DATA AND SPECIFICATIONS (S.D.S.)	★
DESCRIPTION	★	TROUBLE DIAGNOSES AND CORRECTIONS	★
STRUCTURE AND OPERATION	EF-2		
INSPECTION AND ADJUSTMENT	EF-3		

EF

★: Refer to 1982 DATSUN NISSAN STANZA SERVICE MANUAL.

CARBURETOR

STRUCTURE AND OPERATION

IDLE SPEED CONTROL SYSTEM

This system prevents poor battery charging, erratic idling and a reduced

air conditioning capability when the following units are operating:

- Cooling fan motor
- Headlamps
- Oil pump for power steering (if equipped)
- Heater or air conditioner fan

- Air conditioner (if equipped)

In this system, the proper fuel is added to keep a constant idle speed when solenoid valve No. 1 and/or fast idle pot attached to carburetor are in the "ON" position.

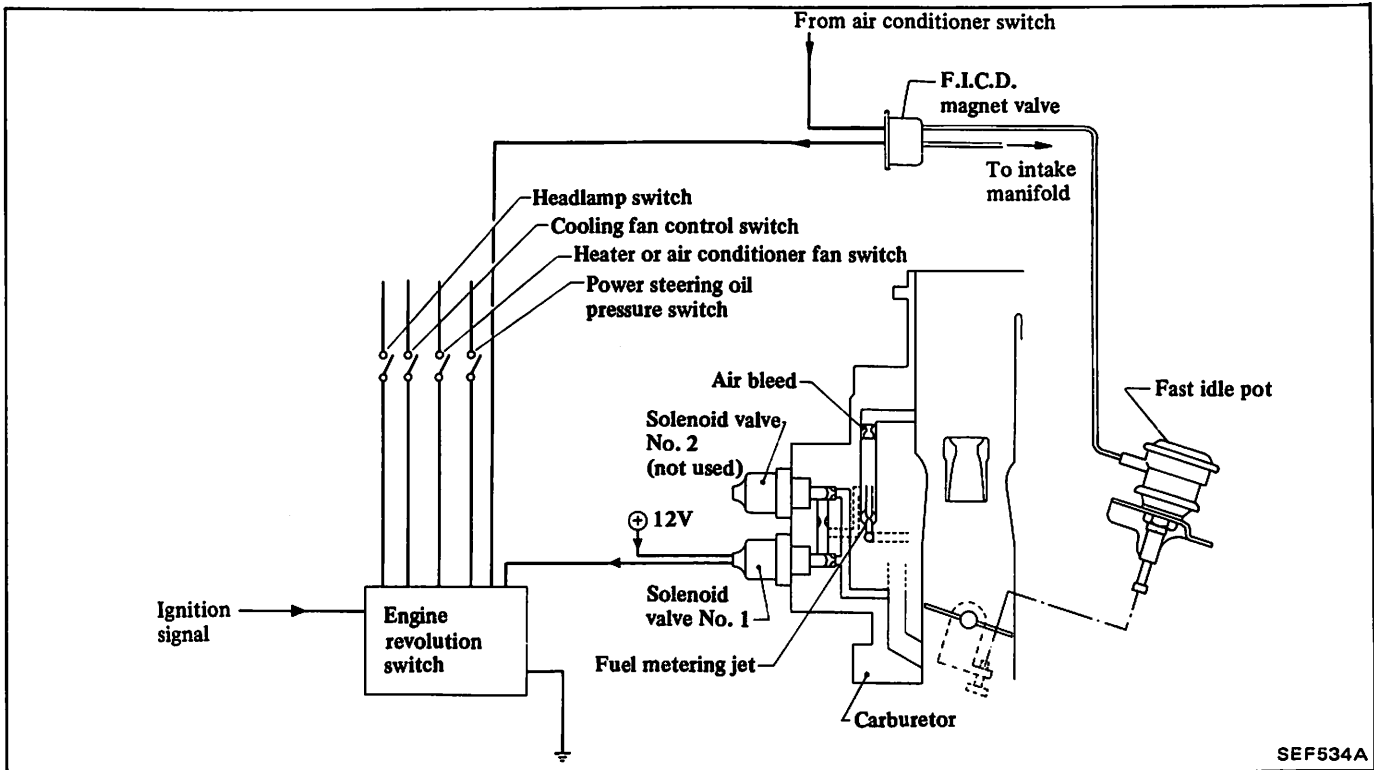

Operation

Engine speed	Switch operation			Engine revolution switch operation		Solenoid valve No. 1	Fast idle pot
	Headlamp switch Cooling fan control switch Power steering oil pressure switch	Heater or air conditioner fan switch	Air conditioner switch	Switch for solenoid valve No. 1	Switch for F.I.C.D. magnet valve		
Higher than 2,200 rpm	In any case			OFF	OFF	OFF	OFF
Between 2,200 rpm and 1,400 rpm	Some one: ON		In any case	ON	OFF	ON	OFF
	All: OFF			OFF	OFF	OFF	OFF
Lower than 1,400 rpm	Some one: ON	ON	ON	ON	ON	ON	ON
			OFF	ON	ON	ON	OFF
		OFF	OFF	ON	ON	ON	OFF
	All: OFF	ON	ON	ON	ON	ON	ON
			OFF	ON	ON	ON	OFF
		OFF	OFF	OFF	ON	OFF	OFF

INSPECTION AND ADJUSTMENT

CARBURETOR IDLE-R. P. M. AND MIXTURE RATIO

The idle mixture adjusting screw which has been preset at the factory should be adjusted only in the event of a major carburetor overhaul, throttle body replacement or to lower exhaust emissions as directed by official inspections.

This screw should not be readjusted during routine maintenance.

Adjusting mixture using other than the method below may violate Federal, or other state and Provincial laws.

Preparation

1. Make sure that the following parts are in good order.

- Ignition system
 - Engine oil and coolant levels
 - Valve clearance
2. Connect engine tachometer and timing light in their proper positions.
 3. Insure that these switches and units are in the following positions:
 - Headlamp switch: OFF
 - Heater blower: OFF
 - Air conditioning switch: OFF (if equipped)
 - Steering: **KEEP WHEELS STRAIGHT AHEAD** (if equipped with power steering)
 4. Make the check after the radiator cooling fan has stopped. If it is operating, wait until it stops.
 5. Apply parking brake and block both front and rear wheels with chocks.
 6. When measuring "CO" percentage, insert probe more than 40 cm

(15.7 in) into tail pipe.

WARNING:

- a. Inspections should be carried out while shift lever is in "D" position on automatic transmission equipped models and in "Neutral" on manual transmission equipped models.
- b. On automatic transmission equipped models, racing the engine should be carried out while shift lever is in "N" or "P" position and brake pedal should be depressed.
- c. After adjustment has been made, shift the lever to "N" or "P" position.

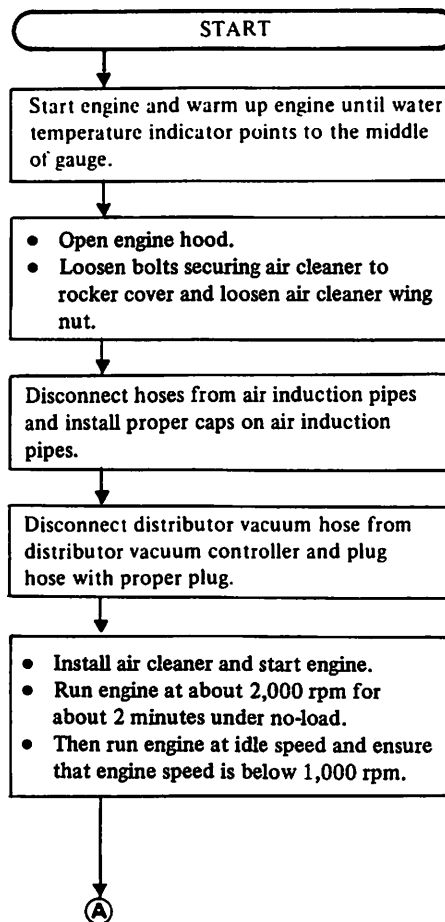

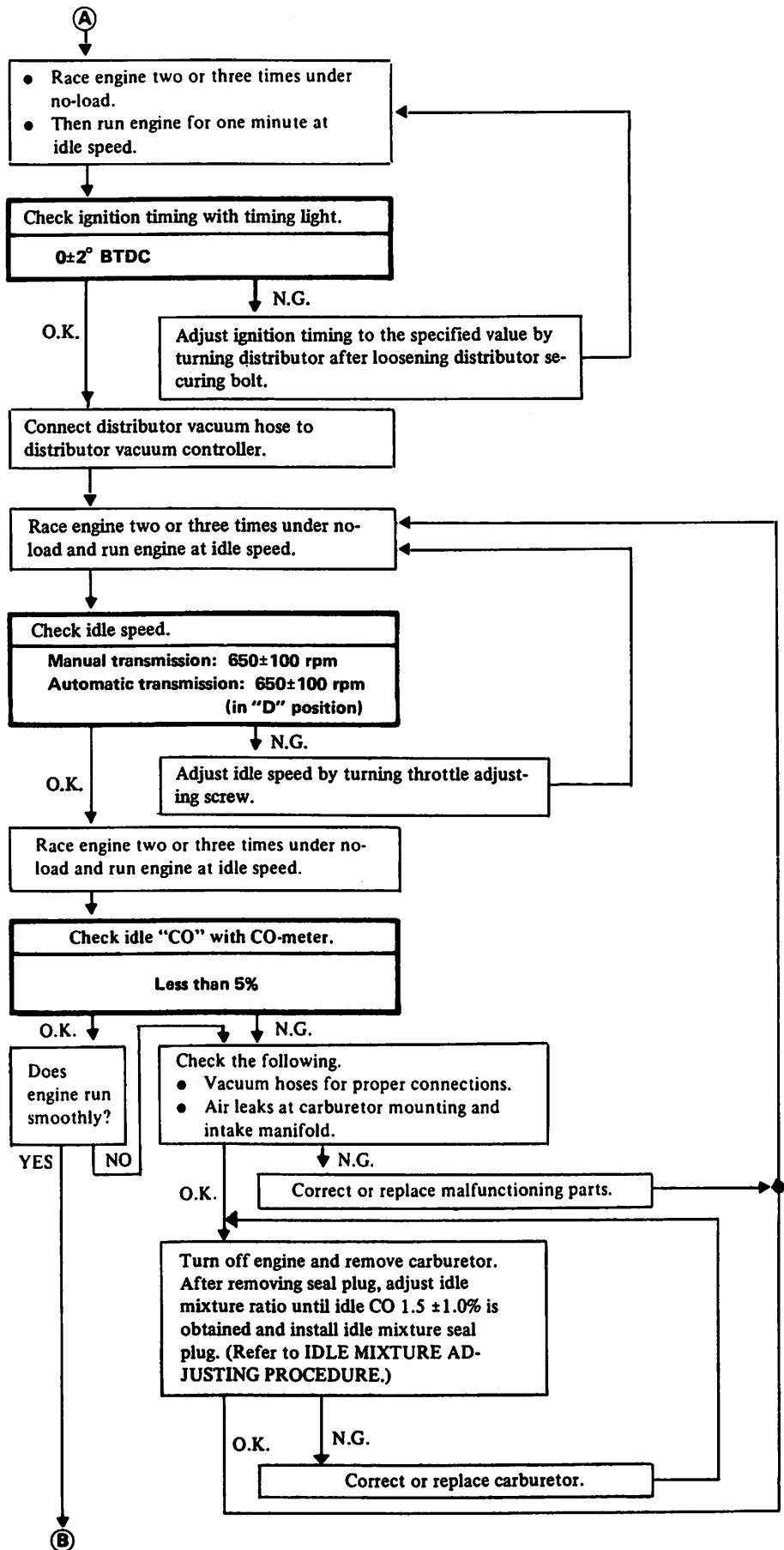

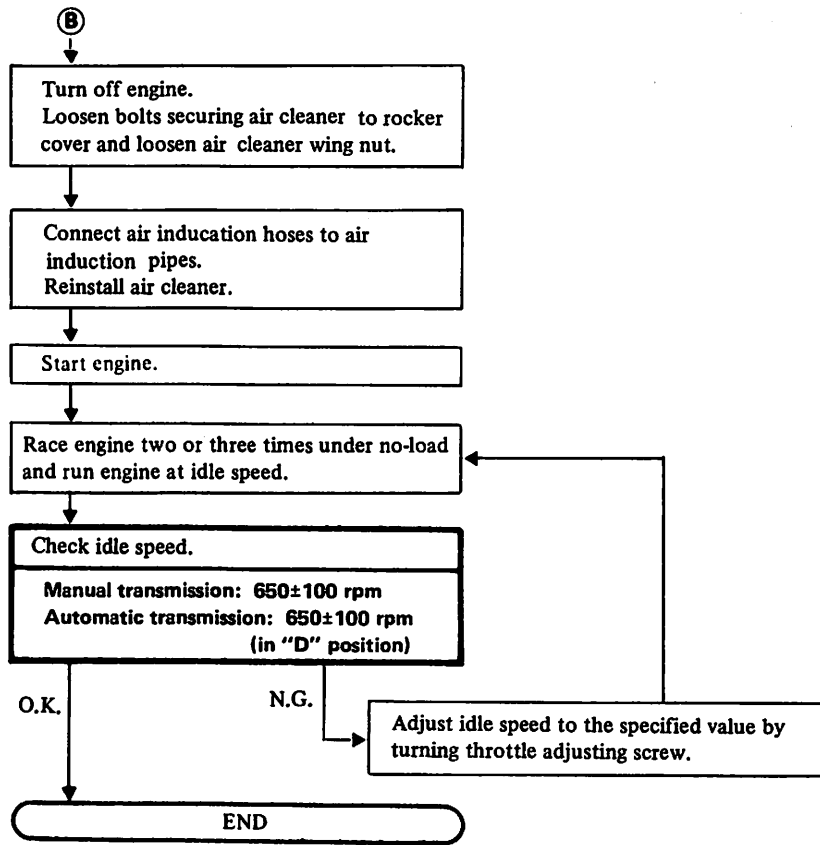

IDLE SPEED CONTROL

Check the system after engine has sufficiently warmed up.

1. Stop engine and disconnect har-

ness connector on carburetor.

2. Connect proper wires between each connector as follows:

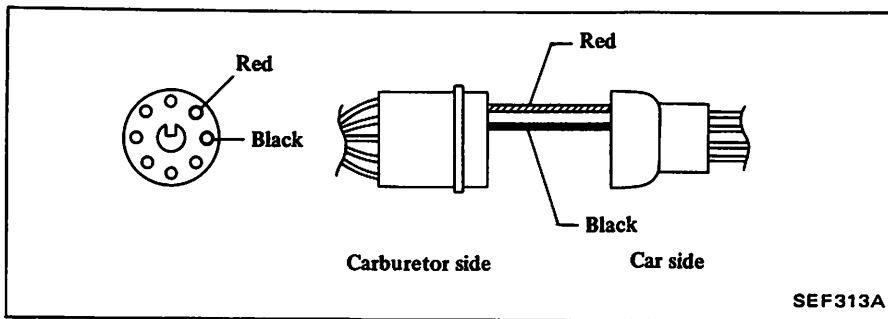

3. Start engine, and confirm idle speed at that time. Adjust it if necessary.

4. Apply battery voltage to solenoid valve No. 1 connectors.

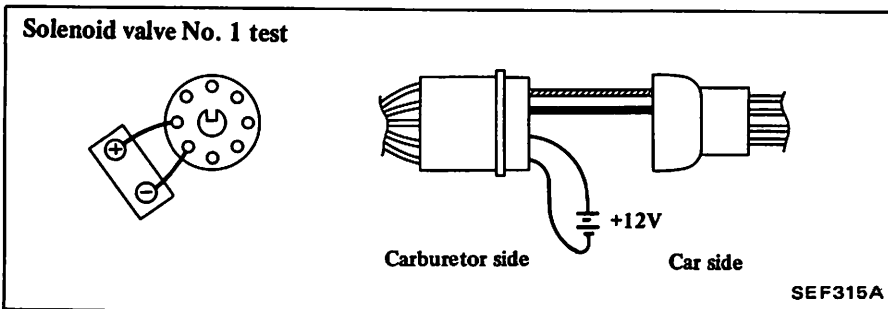

5. Then, make sure that engine speed increases. If not, replace solenoid valve No. 1.

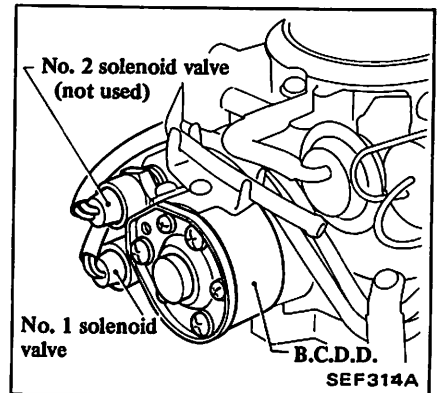

6. Remove battery voltage from connector.

Then, make sure that engine speed decreases when each of the following switches is operated:

- Headlamp switch
- Heater or air conditioner fan switch
- Cooling fan control switch (Refer to LC section)
- Power steering oil pressure switch (if equipped)

If not, check or replace each switch as applicable.

Turn steering wheel to make power steering oil pressure switch operate.

7. Stop engine and return each switch to the position it was in before step 6. Then, disconnect the wires and connect two connectors between carburetor and engine room harness.

8. Make sure that engine speed is kept at the preset range when the above switches are operated in the same way as in step 6.

If not, replace engine revolution switch.

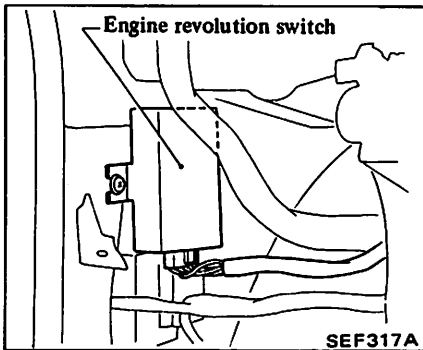

DASH POT

Turn air conditioner switch "OFF" (if equipped).

1. Warm engine to operating temperature and check idle speed.

2. Turn throttle valve and check engine speed when dash pot (or fast idle pot for air conditioner equipped model) just touches stopper lever.

Dash pot touch speed:
1,400 - 1,600 rpm

3. If out of specification, adjust it by turning adjusting screw.

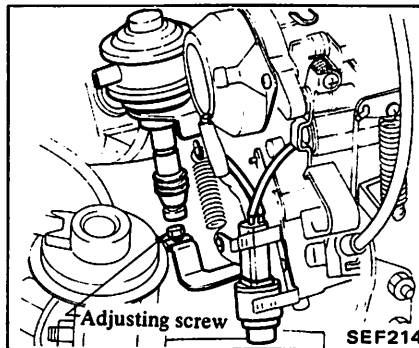

4. For air conditioner equipped model, adjust fast idle pot as follows.

(1) Verify that engine is still at operating temperature.

(2) Turn air conditioner switch "ON" and check engine speed.

Specified engine speed:
600 - 650 rpm

Shift lever position: "D"
Fan switch position: "4" or "HI"

(3) If out of specification, adjust it by turning fast idle adjusting screw.

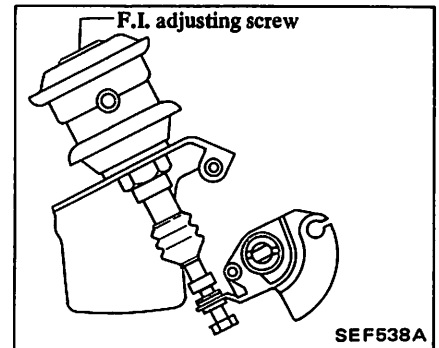

EMISSION CONTROL SYSTEM

SECTION EC

CONTENTS

EMISSION CONTROL DEVICES	EC-2	FUEL SHUT-OFF SYSTEM	★
GENERAL DESCRIPTION	★	HIGH ALTITUDE EMISSION CONTROL SYSTEM	EC-6
CRANKCASE EMISSION CONTROL SYSTEM	★	DESCRIPTION	EC-6
EXHAUST EMISSION CONTROL SYSTEM	EC-3	INSTALLATION AND MODIFICATION PROCEDURE	EC-7
DESCRIPTION	EC-3	EVAPORATIVE EMISSION CONTROL SYSTEM	★
AIR INDUCTION SYSTEM	★	SERVICE DATA AND SPECIFICATIONS (S.D.S.)	★
EXHAUST GAS RECIRCULATION (E.G.R.) CONTROL SYSTEM	★		
SPARK TIMING CONTROL SYSTEM	★		
SPARK PLUG SWITCHING CONTROL SYSTEM	EC-4		

★: Refer to 1982 DATSUN NISSAN STANZA SERVICE MANUAL.

EC

* Only for models operating at high altitudes in U.S.A.

EMISSION CONTROL DEVICES

Item	Engine model	CA20S			
		Destination	U.S.A.		Canada
			California models		Non-California models
		Transmission	A/T	M/T	A/T
Air inlet system	Automatic temperature control air cleaner		X		X
	Fresh air duct		X		X
	Early fuel evaporative system (Hot water type)		X		X
	Hot idle compensator		X		X
Carburetor	P.T.C. auto choke (Full auto)		X		X
	Altitude compensator		X		X*
Ignition system	IC ignitor		X		X
	Water temperature control system		X		X
	Spark plug switching control system		X		X
	Idle advance control system		X		X
Air induction system	Exhaust air induction (E.A.I.) type		X		X
E.G.R. system	E.G.R. system with V.V.T. valve (type-A)		—		X
	E.G.R. system with V.V.T. valve (type-B)		X		—
Deceleration control system	Fuel shut-off system		X		X
	B.C.D.D.		X		X
Catalyzer	Oxidation catalytic converter		X		X
Evaporator system	Canister		X		X
Crankcase ventilation system	P.C.V.		X		X

* Only for models operating at high altitudes in U.S.A.

EXHAUST EMISSION CONTROL SYSTEM

DESCRIPTION

Destination Emission control system	California models	Non-California models
Air induction system	<ul style="list-style-type: none"> ● Air induction valve ● E.A.I. pipe ● A.B. valve 	<ul style="list-style-type: none"> ● Air induction valve ● E.A.I. pipe ● A.B. valve
E.G.R. system	<ul style="list-style-type: none"> ● E.G.R. valve ● Thermal vacuum valve (3-port type) ● V.V.T. valve ● Vacuum control valve ● Reservoir tank ● Vacuum delay valve ● One-way valve 	<ul style="list-style-type: none"> ● E.G.R. valve ● Thermal vacuum valve (3-port type) ● V.V.T. valve
Spark timing control system	<ul style="list-style-type: none"> ● Thermal vacuum valve (3-port type) ● Vacuum tank of distributor ● Vacuum control valve 	<ul style="list-style-type: none"> ● Thermal vacuum valve (3-port type) ● Vacuum tank of distributor ● Vacuum control valve
Spark plug switching control system	<ul style="list-style-type: none"> ● Distributor ● Ignition coil ● Vacuum switch ● Inhibitor switch (A/T models) ● Clutch switch (M/T models) ● Neutral switch (M/T models) 	<ul style="list-style-type: none"> ● Distributor ● Ignition coil ● Vacuum switch ● Inhibitor switch (A/T models) ● Clutch switch (M/T models) ● Neutral switch (M/T models)
Fuel shut-off system	<ul style="list-style-type: none"> ● Engine revolution switch ● Throttle valve switch ● Anti-dieseling solenoid valve ● Ignition coil 	<ul style="list-style-type: none"> ● Engine revolution switch ● Throttle valve switch ● Anti-dieseling solenoid valve ● Ignition coil
Boost controlled deceleration device (B.C.D.D.)	<ul style="list-style-type: none"> ● B.C.D.D. unit 	<ul style="list-style-type: none"> ● B.C.D.D. unit
Catalyst	<ul style="list-style-type: none"> ● Oxidation catalytic converter 	<ul style="list-style-type: none"> ● Oxidation catalytic converter

SPARK PLUG SWITCHING CONTROL SYSTEM

OPERATION

This system is composed of ignition

control unit, which is installed in distributor and has a switching function which allows it to change from 2-plug ignition to 1-plug ignition, and vacuum switch which senses the intake mani-

fold vacuum. Neutral switch, clutch switch (M/T models) and inhibitor switch (A/T models) are also used as auxiliary control devices.

Engine operation condition			Switch operation		Ignition control		
Load	Transmission gear position or clutch operation		Transmission gear position switch or clutch switch	Vacuum switch	Spark control	Spark timing	
	A/T	M/T					
Cranking	"P" or "N" position	Neutral or clutch is disengaged	ON	OFF	2-spark plug system	Normal	
	Light load	"P" or "N" position	Neutral or clutch is disengaged	ON	ON	2-spark plug system	Normal
Drive		Other		OFF	ON	2-spark plug system	Normal
Heavy load	Drive	Other		OFF	OFF	1-spark plug system	Advanced

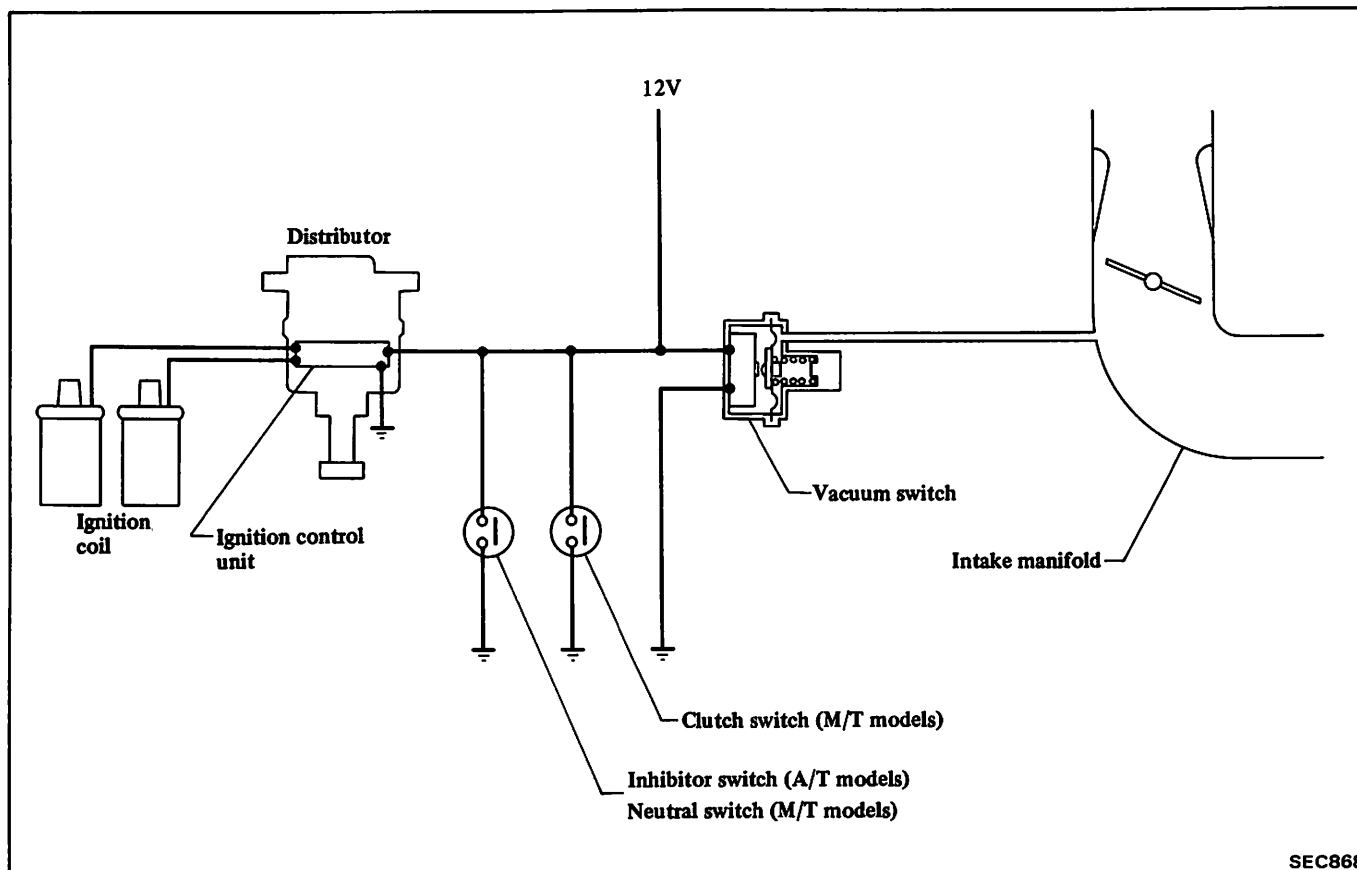

SEC868

Refer to electric circuit in EL section.

Operational modes of each switch should be as follows:

		Condition	
		Switch "ON"	Switch "OFF"
Vacuum switch		Intake manifold vacuum normal level	Intake manifold vacuum low level [Below -10.7 kPa (-80 mmHg, -3.15 inHg)]
A/T	Inhibitor switch	Gear position: "P" or "N" position	Other positions
M/T	Neutral switch	Gear position: Neutral position	Other positions
	Clutch switch	Clutch disengaged	Clutch engaged

3. Set a timing light to the exhaust side of high tension cable.
4. Apply vacuum -20.0 kPa (-150 mmHg, -5.91 inHg) to vacuum switch and start engine.
5. Then, reduce the vacuum gradually and make sure that a timing light does not brighten and dim when a vacuum reaches to about -10.7 kPa (-80 mmHg, -3.15 inHg) or less. If not, check each component and replace it if necessary.
6. Reset a timing light to the intake side of high tension cable. Apply vacuum -20.0 kPa (-150 mmHg, -5.91 inHg) to vacuum switch.
7. Then, reduce the vacuum gradually and make sure that a spark timing advances.

If not, replace IC unit in the distributor.

INSPECTION

Entire system

1. Disconnect inhibitor switch harness connector (A/T models) or clutch switch harness connector (M/T models).
2. Disconnect a vacuum hose of vacuum switch, and connect a proper vacuum hose and a variable vacuum source to vacuum switch.

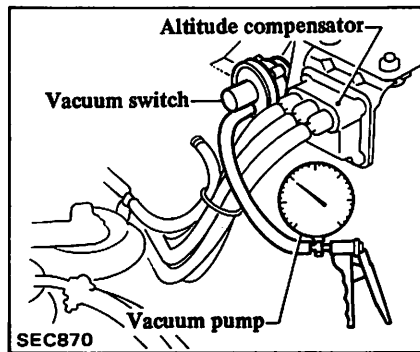

HIGH ALTITUDE EMISSION CONTROL SYSTEM

DESCRIPTION

In cars operated at high altitudes, where the air is thinner, mixture ratio and intake manifold boost vary, and exhaust emission increases. In order to decrease exhaust emission, certain devices have to be added/changed.

The following devices have to be added.

1. Altitude compensator ... For control of mixture ratio
2. Canister ... For reduction of vapor in carburetor float chamber

Control devices and system charts are as follows:

	Parts
Modification of mixture ratio	Altitude compensator with bracket
	Vacuum hoses and connectors
Reduction of vapor in carburetor float chamber	Canister
	Vacuum hoses and connectors

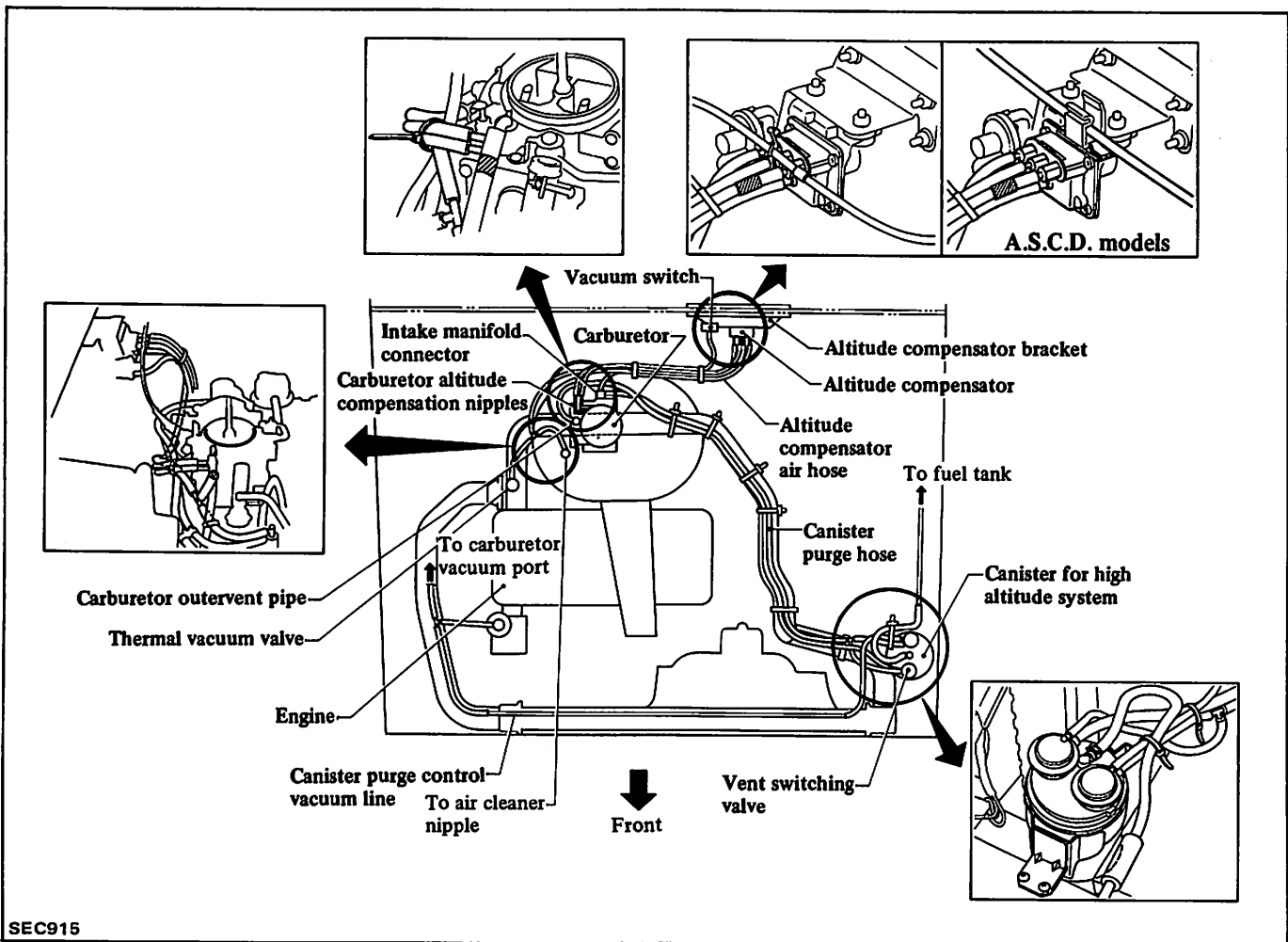

SEC915

To install devices, refer to procedures in INSTALLATION AND MODIFICATION PROCEDURE.

INSTALLATION AND MODIFICATION PROCEDURE

Before installation or modification, assemble applicable components into subassemblies if necessary.

1. Remove air cleaner from engine.
2. Remove blind caps attached to altitude compensation pipes and outer vent pipe of carburetor.

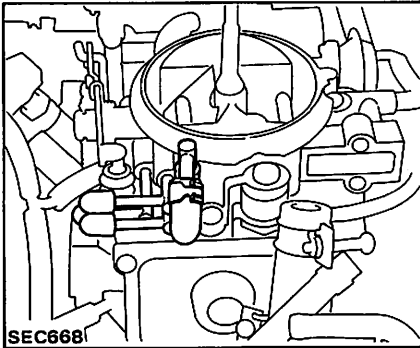

3. Remove air duct and canister from car. Then, install a new canister which is designed for vehicles operating at high altitudes.

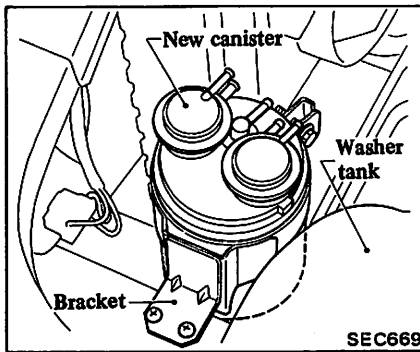

4. Connect hoses for fuel tank vapor vent line and vacuum signal line.
5. Cut off canister purge hose at the canister side leaving about 100 mm (4 in) (same as the canister diameter). Then, insert a 3-way connector with a vacuum hose, and connect vacuum hose to canister outer vent pipe.

Remove bands that were installed. Clamp hoses with those bands as shown.

When connecting outer vent hose, make sure that the identification mark on the hose is at the end to be connected to the carburetor side.

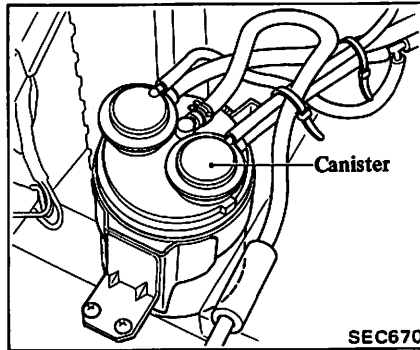

6. Connect outer vent hose to carburetor leading it along the canister purge hose. Then, clamp the outer vent hose in a manner similar to the purge hose.

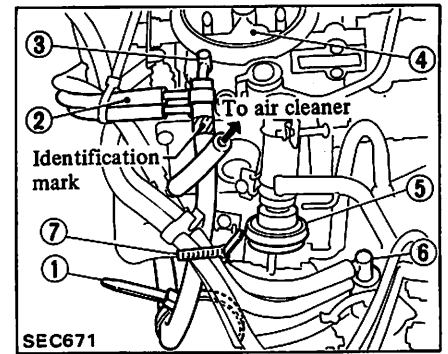

- 1 Band
- 2 To altitude compensator
- 3 Outer vent pipe
- 4 Carburetor
- 5 A.B. valve
- 6 T.V.V.
- 7 Purse lock

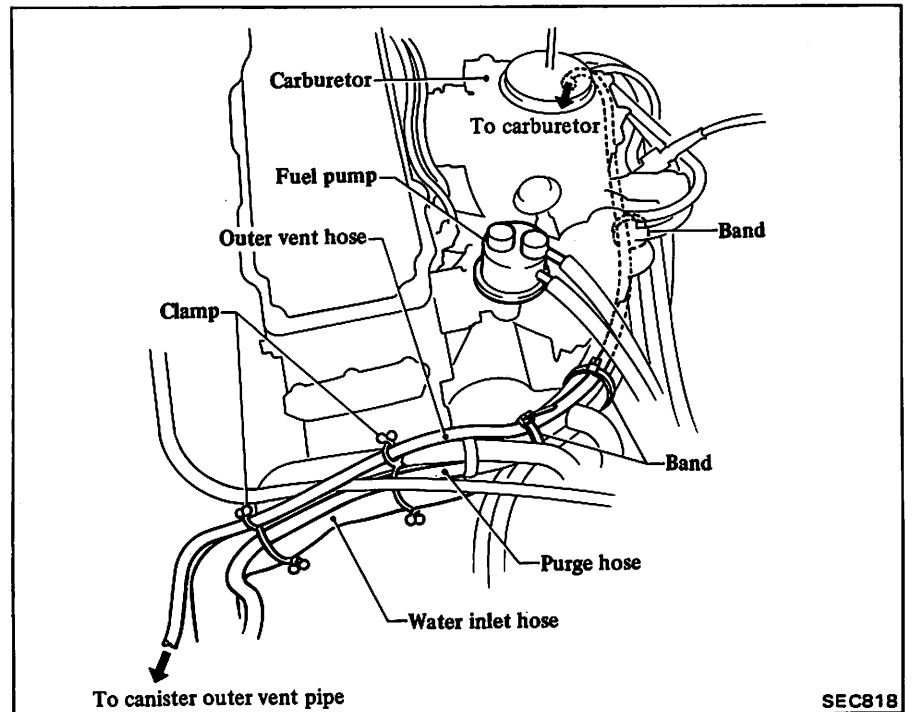

7. Remove vacuum switch and bracket from the car. Then, install an altitude compensator with new bracket on the car.

Finally, reinstall a vacuum switch.

Make sure that the harness connector and vacuum hose are securely connected.

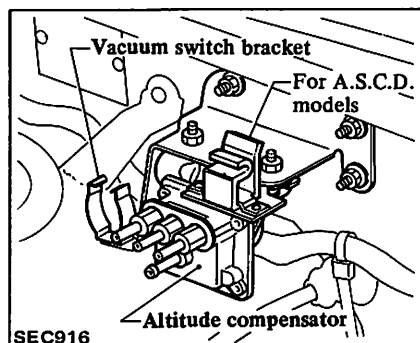

8. Connect vacuum hoses between carburetor and altitude compensator. After connecting, secure them with clamps and hose bands as follows:

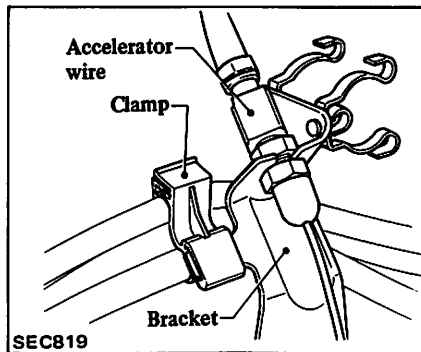
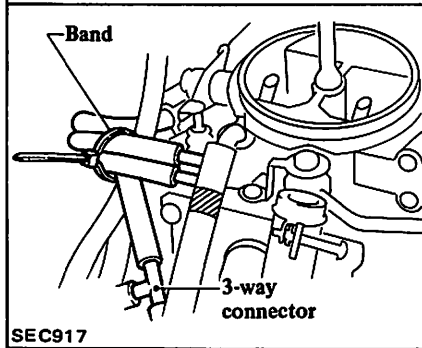
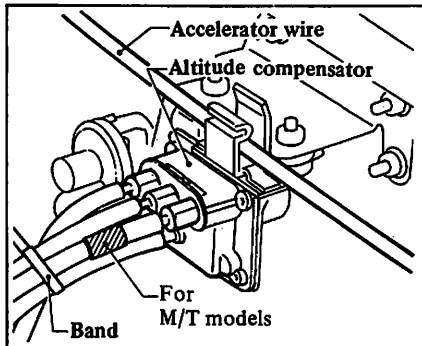

9. Remove air hose between air cleaner and T.V.V. Then connect a vacuum hose assembly between air cleaner, altitude compensator and T.V.V.

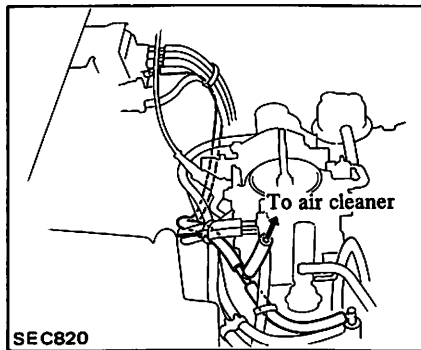

10. Reinstall air cleaner on the engine.

Make sure that all hoses are connected correctly and don't interfere with other components.

11. Start engine and check air and vacuum lines for leaks, particularly around new connections.

If O.K., warm up engine sufficiently.

12. Check idle speed and adjust it if necessary.

ENGINE CONTROL, FUEL & EXHAUST SYSTEMS

SECTION FE

CONTENTS

ENGINE CONTROL SYSTEM	FE-2	EXHAUST SYSTEM	★
ACCELERATOR SYSTEM	FE-3	SERVICE DATA AND SPECIFICATIONS (S.D.S.)	★
FUEL SYSTEM	★		

★ : Refer to 1982 DATSUN NISSAN STANZA SERVICE MANUAL.

FE

ENGINE CONTROL SYSTEM

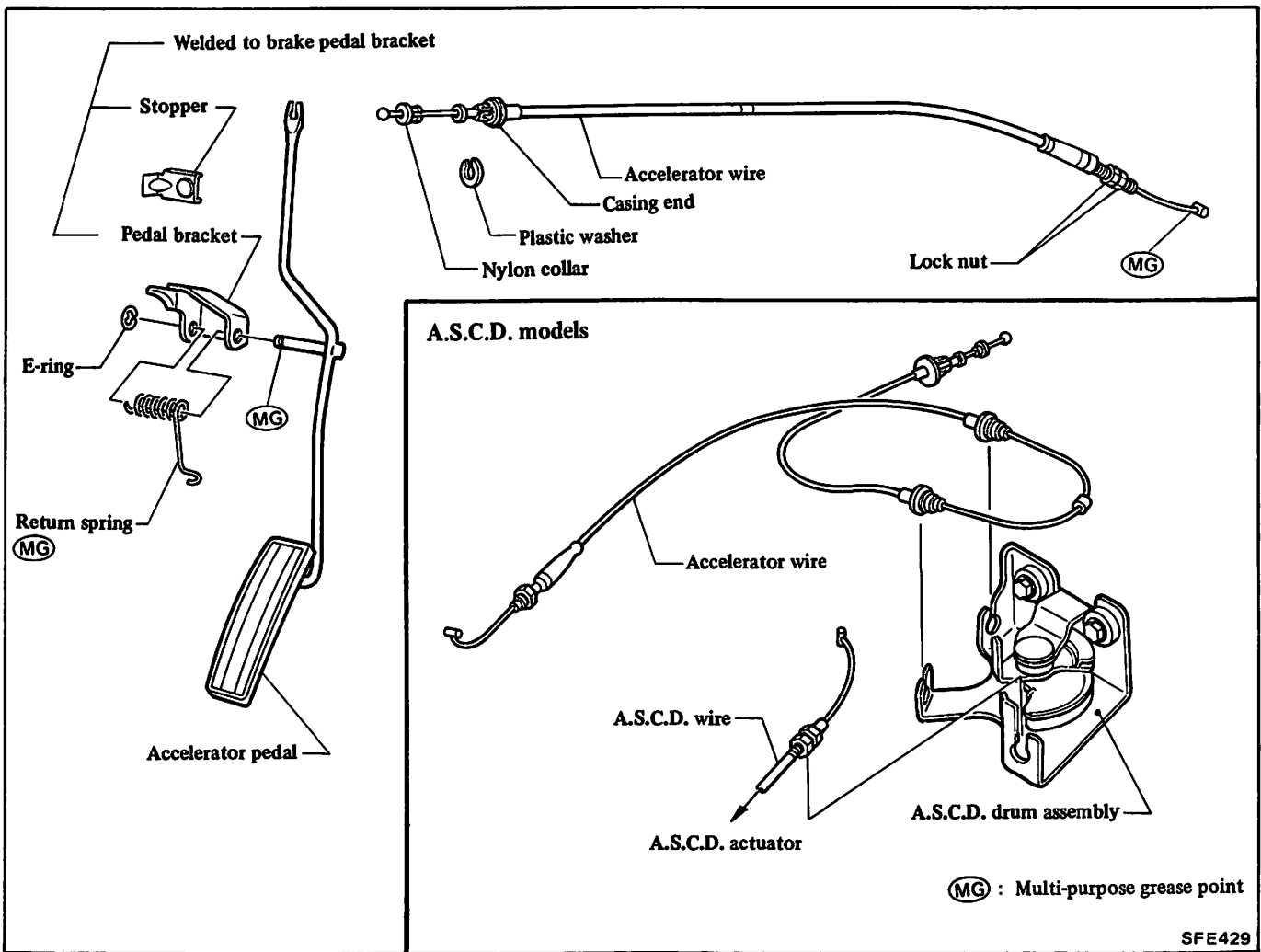

ACCELERATOR SYSTEM

ACCELERATOR WIRE

Removal and installation

- Remove accelerator wire in the order of 1 to 8.
- Install in the reverse order of removal.

1. Disconnect battery ground cable.
2. Remove instrument lower cover.

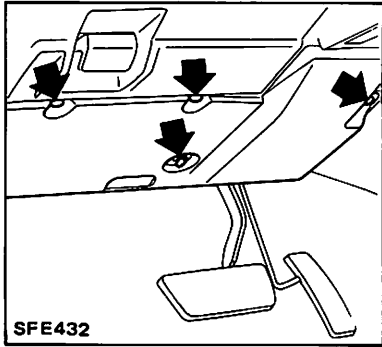

5. Remove air cleaner.
6. Disconnect wire from carburetor.

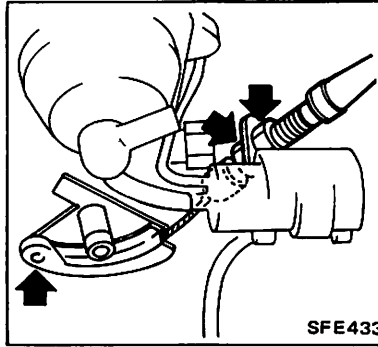

3. Disconnect wire at pedal arm.

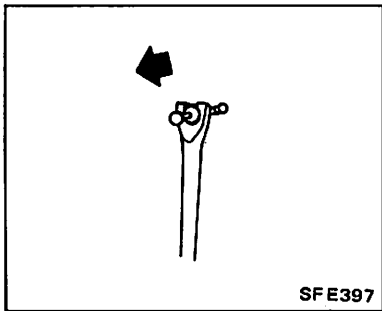

7. Disconnect wire at A.S.C.D. drum.

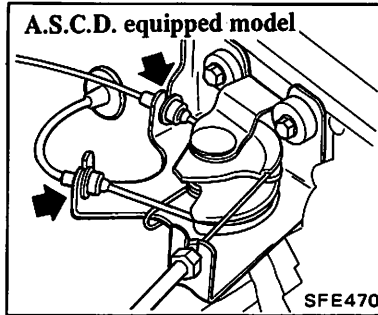

4. Remove plastic washer.

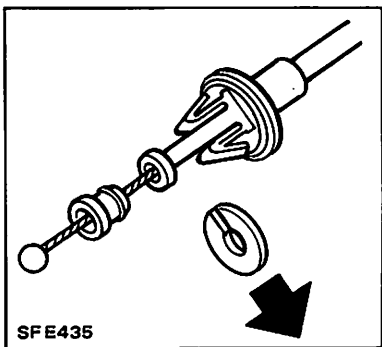

8. Take wire out from engine compartment.

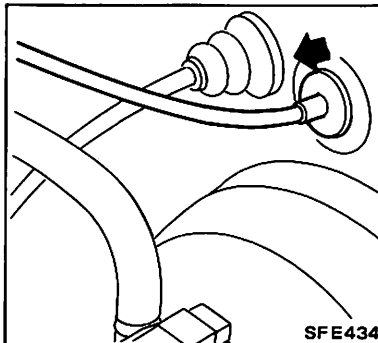

- a. Be careful not to damage or bend the wire.

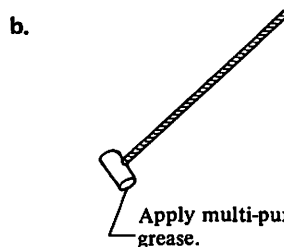

AUTOMATIC TRANSAXLE

SECTION AT

CONTENTS

DESCRIPTION	AT- 2	ADJUSTING END PLAY OF OUTPUT SHAFT	AT-36
HYDRAULIC CONTROL UNIT AND VALVES	AT- 4	FINAL ASSEMBLY	AT-37
HYDRAULIC CONTROL CIRCUITS	AT- 7	TROUBLE-SHOOTING AND DIAGNOSES	AT-42
ON-VEHICLE SERVICE	AT- 8	PRELIMINARY CHECKS	
CONTROL VALVE ASSEMBLY	AT- 8	(Prior to road testing)	AT-42
THROTTLE WIRE	AT- 8	DIAGNOSTIC ROAD TEST	AT-43
GOVERNOR SHAFT ASSEMBLY	AT- 9	PRESSURE TESTING	AT-45
INHIBITOR SWITCH	AT- 9	STALL TESTING	AT-45
BEARING RETAINER OIL SEAL	AT- 9	TROUBLE-SHOOTING CHART	AT-47
CONVERTER HOUSING OIL SEAL	AT-10	ROAD TEST SYMPTOM CHART	AT-50
MINOR ADJUSTMENTS	AT-11	TROUBLE-SHOOTING GUIDE FOR RN3F01A AUTOMATIC TRANSAXLE	AT-51
REMOVAL AND INSTALLATION	AT-13	SERVICE DATA AND SPECIFICATIONS (S.D.S.)	AT-53
TRANSAXLE ASSEMBLY	AT-13	GENERAL SPECIFICATIONS	AT-53
MAJOR OVERHAUL OPERATIONS	AT-15	SPECIFICATIONS AND ADJUSTMENT	AT-53
SERVICE NOTES FOR		STALL REVOLUTION	AT-55
DISASSEMBLY	AT-17	TIGHTENING TORQUE	AT-55
DISASSEMBLY	AT-17	SPECIAL SERVICE TOOLS	AT-56
COMPONENT PARTS	AT-21		
ADJUSTING ROTARY FRICTIONAL FORCE			
OF TAPERED ROLLER BEARING	AT-34		

AT

DESCRIPTION

The RN3F01A transaxle is a fully automatic unit consisting primarily of a 3 element hydraulic torque converter, two planetary gear sets and final gear. Two multiple-disc clutches, a multiple-disc brake, brake band, and one-way clutch provide the friction elements necessary to obtain the desired function of the two planetary gear-sets.

A hydraulic control system is used to operate the friction elements and automatic shift controls.

TORQUE CONVERTER

The torque converter is attached to the crankshaft through a flexible drive plate. Heat generated in the torque converter is dissipated by circulating the transaxle fluid through an oil-to-water type cooler in the radiator lower tank.

The welded construction of the torque converter prohibits disassembly or service unless highly specialized equipment is available.

FLUID RECOMMENDATION

Use "DEXRON" type automatic transaxle fluid only.

IDENTIFICATION NUMBER LABEL

Location

The label is pasted on right upper face of transmission case.

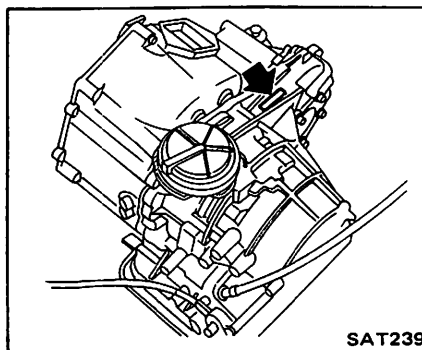

Number designation

0 6 0 1 2 3 4

Serial production number for the month
Month of production
1: Jan., 2: Feb.,
X: Oct., Y: Nov., Z: Dec.

This figure denoting the transaxle model
0: Automatic transaxle 1,2, and A: Manual transaxle

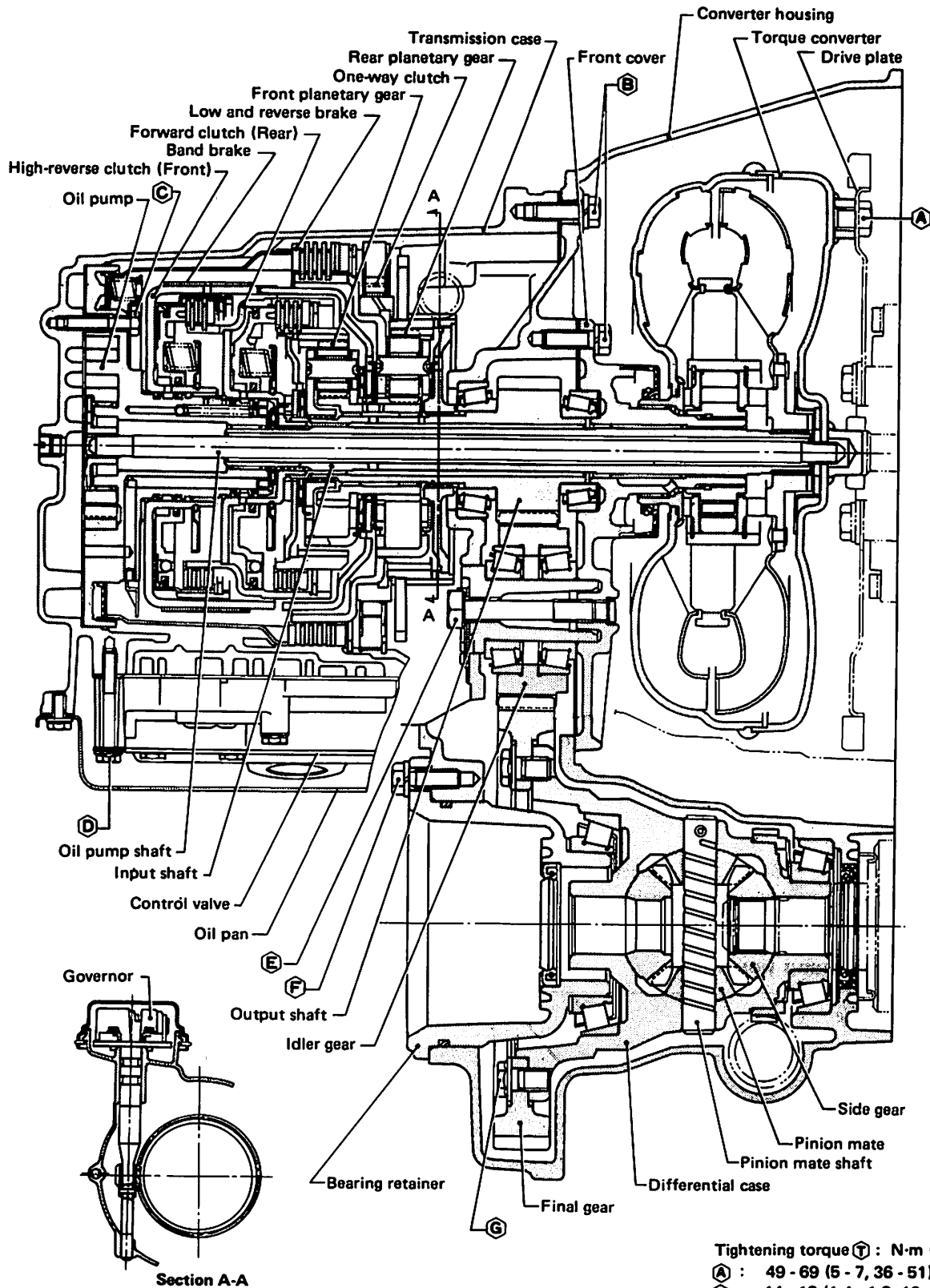

Tightening torque Ⓜ : N·m (kg·m, ft·lb)

- Ⓐ : 49 - 69 (5 - 7, 36 - 51)
- Ⓑ : 14 - 18 (1.4 - 1.8, 10 - 13)
- Ⓒ : 7 - 9 (0.7 - 0.9, 5.1 - 6.5)
- Ⓓ : 7 - 9 (0.7 - 0.9, 5.1 - 6.5)
- Ⓔ : 3 - 4 (0.3 - 0.4, 2.2 - 2.9)
- Ⓕ : 19 - 25 (1.9 - 2.5, 14 - 18)
- Ⓖ : 69 - 78 (7.0 - 8.0, 51 - 58)

HYDRAULIC CONTROL UNIT AND VALVES

Control valve

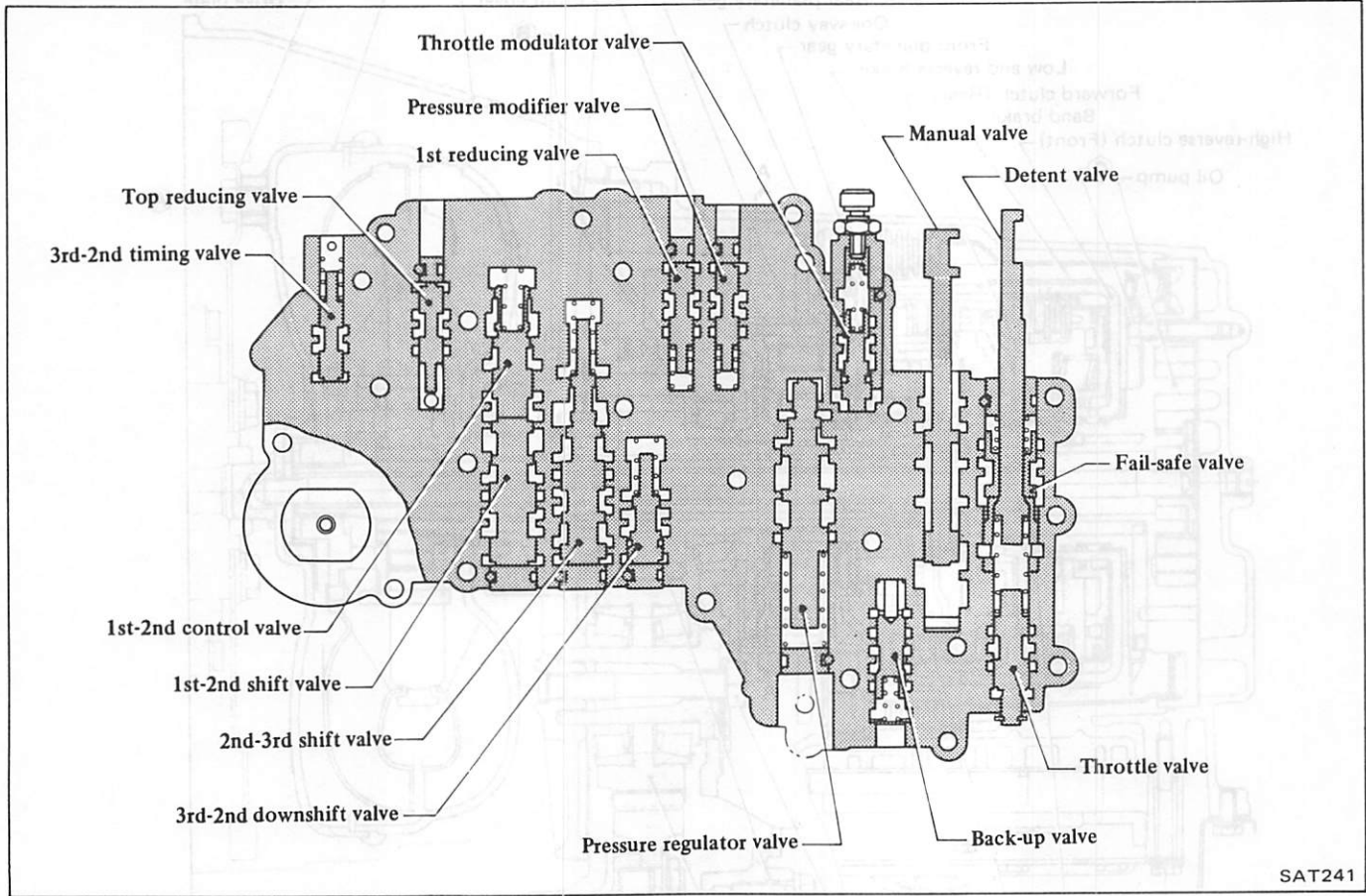

OIL CHANNEL

Oil channels which connect com-

ponents are located in areas shown below.

Oil channels in oil pump housing

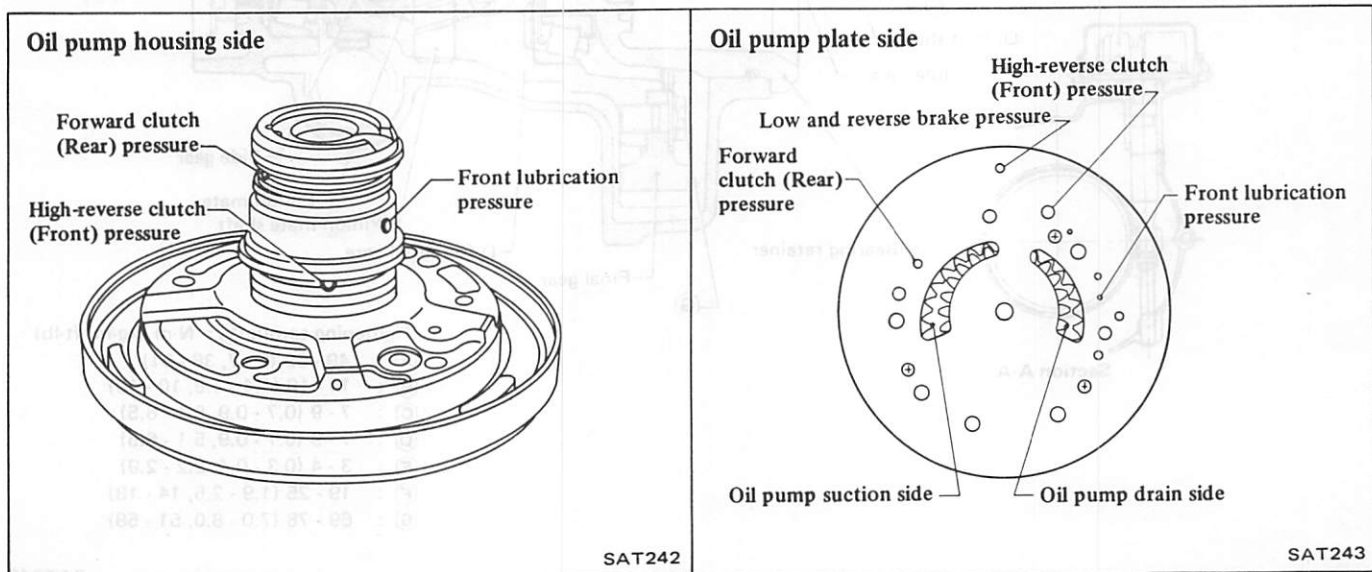

Oil channels in transmission case

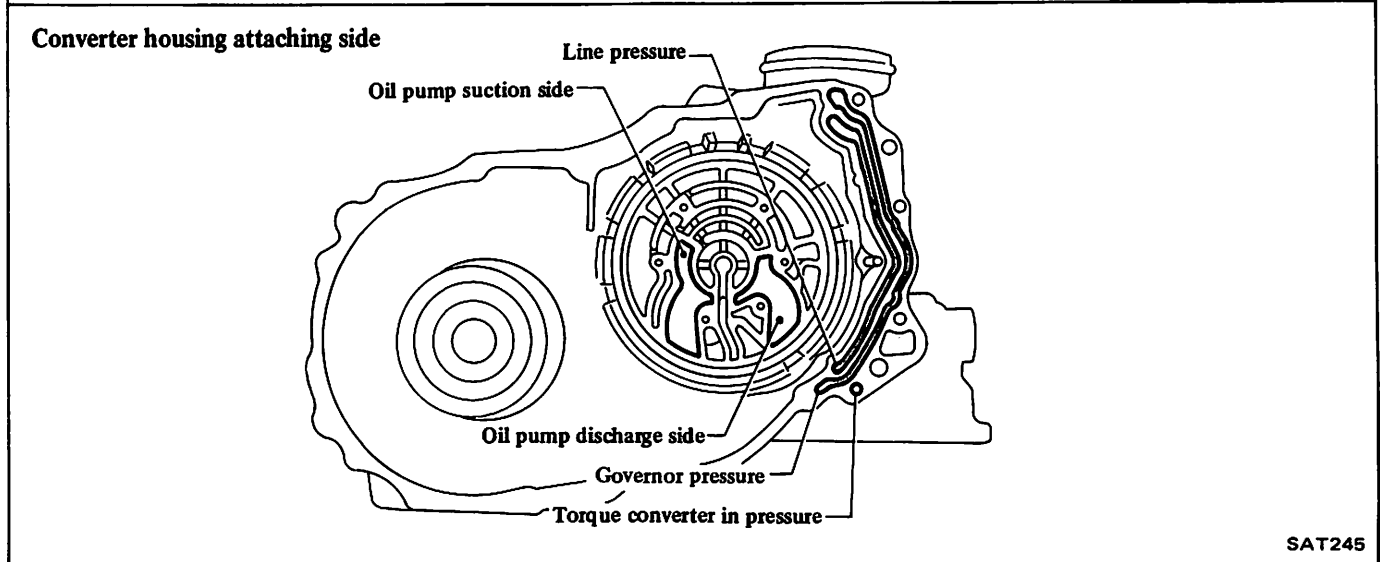
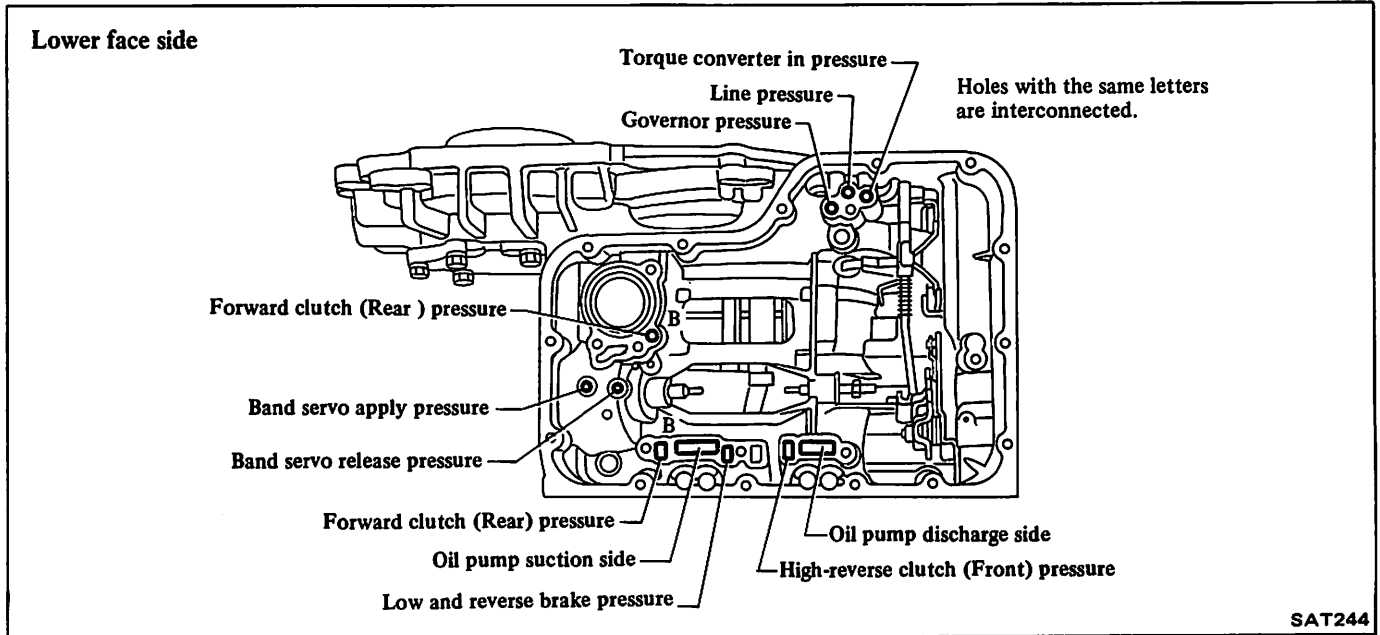

Oil channels in converter housing

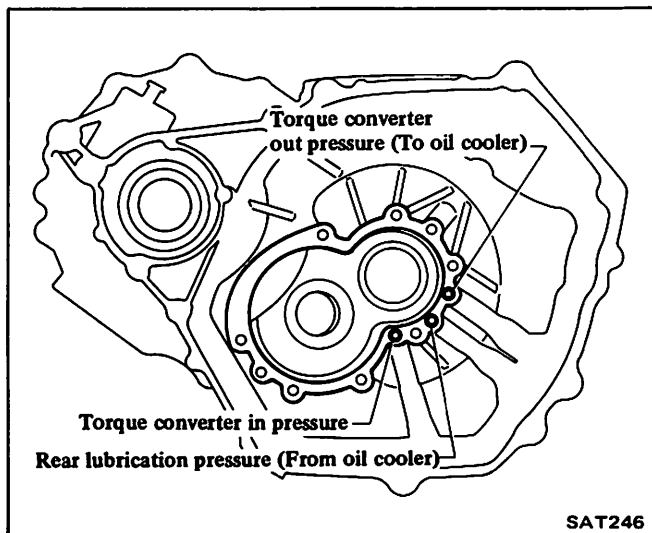

Oil channels in front cover

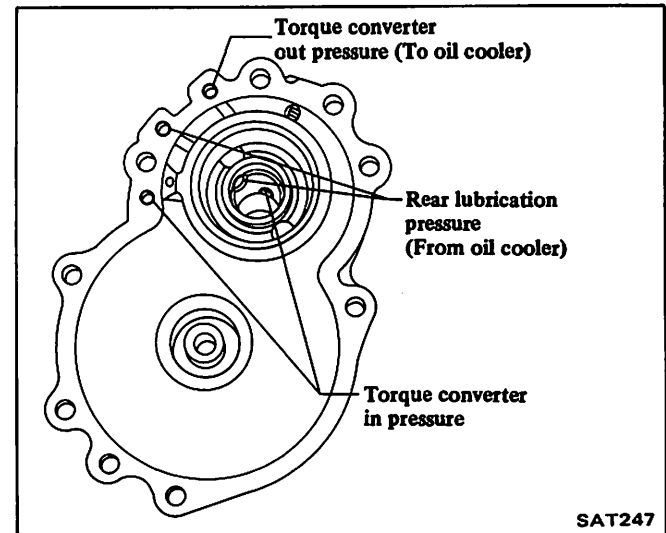

MECHANICAL OPERATION

In the RN3F01A automatic transaxle, each part operates as shown in the following table at each gear select position.







Range	Gear ratio	Clutch		Low & reverse brake	Band servo		One-way clutch	Parking pawl
		High-reverse clutch (Front)	Forward clutch (Rear)		Operation	Release		
Park								on
Reverse	2.364	on		on				
Neutral								
Drive	D ₁ Low	2.826		on			on	
	D ₂ Second	1.543		on	on			
	D ₃ Top (3rd)	1.000	on	on	(on)	on		
2	2 ₁ Low	2.826		on			on	
	2 ₂ Second	1.543		on	on			
1	1 ₁ Low	2.826		on	on		on	
	1 ₂ Second	1.543		on		on		

The low & reverse brake is applied in "1₁" range to prevent free wheeling when coasting and allows engine braking.

HYDRAULIC CONTROL CIRCUITS

Oil Pressure Circuit Diagram - "N" range (Neutral)

Note: Marked X are drain.

- | | |
|--|---|
|  Line pressure (Governor feed pressure) |  Throttle modifier pressure |
|  Governor pressure |  Throttle modulator pressure |
|  Torque converter pressure | |
|  Throttle pressure |  "1" range pressure |

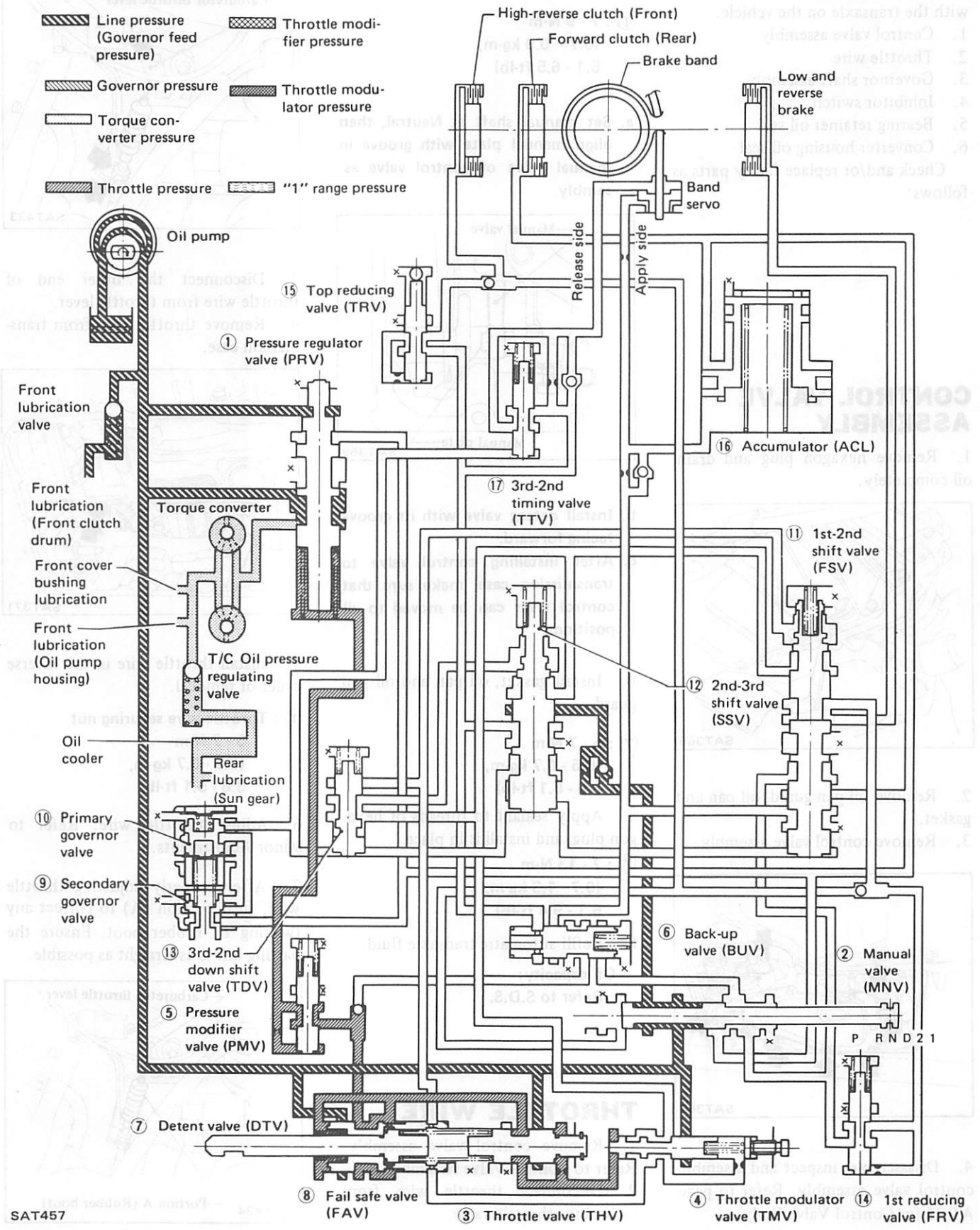

SAT457

ON-VEHICLE SERVICE

The following parts can be serviced with the transaxle on the vehicle.

1. Control valve assembly
2. Throttle wire
3. Governor shaft assembly
4. Inhibitor switch
5. Bearing retainer oil seal
6. Converter housing oil seal

Check and/or replace faulty parts as follows:

CONTROL VALVE ASSEMBLY

1. Remove hexagon plug and drain oil completely.

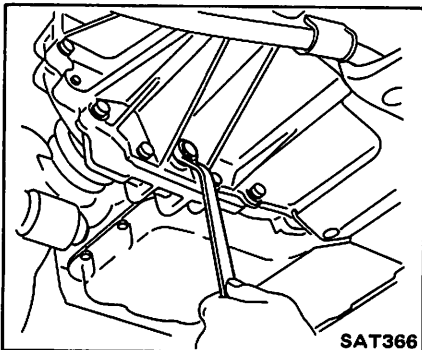

2. Remove oil pan guard, oil pan and gasket.
3. Remove control valve assembly.

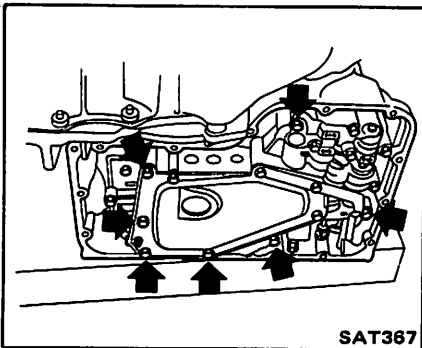

4. Disassemble, inspect and assemble control valve assembly. Refer to page AT-23 for Control Valve Body.

5. Install control valve assembly.

⊕ : 7 - 9 N-m
(0.7 - 0.9 kg-m,
5.1 - 6.5 ft-lb)

- a. Set manual shaft at Neutral, then align manual plate with groove in manual valve of control valve assembly.

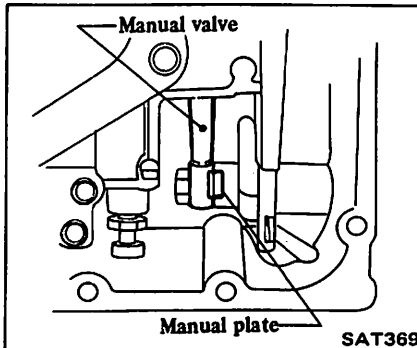

- b. Install detent valve with its groove facing forward.
- c. After installing control valve to transmission case, make sure that control lever can be moved to all positions.

6. Install gasket, oil pan and oil pan guard.

⊕ : 5 - 7 N-m
(0.5 - 0.7 kg-m,
3.6 - 5.1 ft-lb)

7. Apply sealant to threads of hexagon plug, and install it in place.

⊕ : 7 - 13 N-m
(0.7 - 1.3 kg-m,
5.1 - 9.4 ft-lb)

8. Refill automatic transaxle fluid.

Oil capacity:
Refer to S.D.S.

THROTTLE WIRE

1. Remove control valve assembly. Refer to Control Valve Assembly.
2. Disconnect throttle wire from carburetor throttle valve.

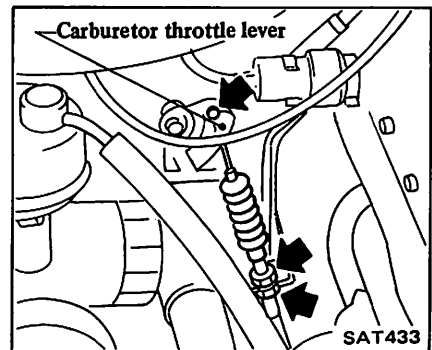

3. Disconnect the other end of throttle wire from throttle lever.
4. Remove throttle wire from transmission case.

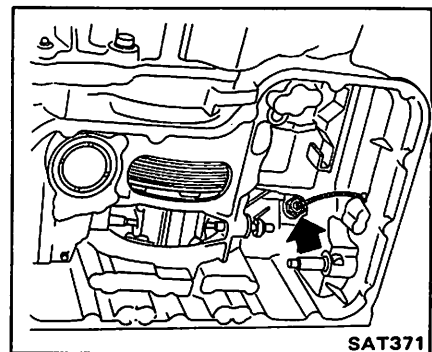

5. Install throttle wire in the reverse order of removal.

⊕ : Throttle wire securing nut
5 - 7 N-m
(0.5 - 0.7 kg-m,
3.6 - 5.1 ft-lb)

6. Adjust throttle wire. Refer to Minor Adjustments.

7. After properly adjusting throttle wire, turn portion (A) to correct any twisting of rubber boot. Ensure the parting line is as straight as possible.

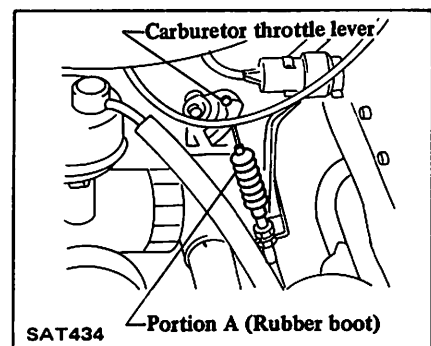

GOVERNOR SHAFT ASSEMBLY

1. Disconnect battery terminal.
2. Remove radiator reservoir tank.
3. Remove battery.
4. Remove battery support bracket.
5. Remove snap retainer, governor cap with breather hose, and seal ring.

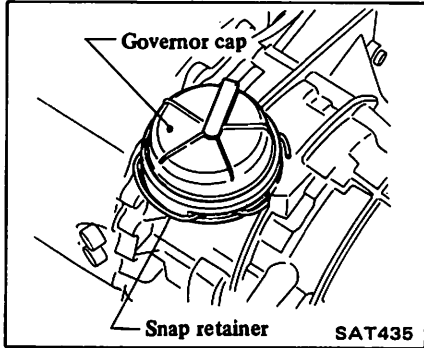

9. Install governor shaft assembly.
10. Install O-ring, governor cap with breather hose, then secure it with snap retainer.

When installing governor cap, pay attention to its direction.

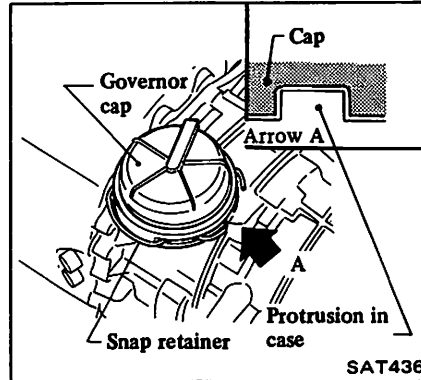

6. Remove governor shaft securing bolt.

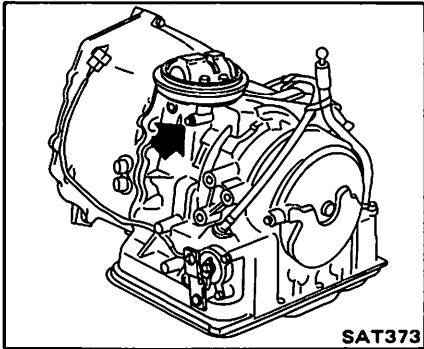

7. Remove governor shaft assembly.

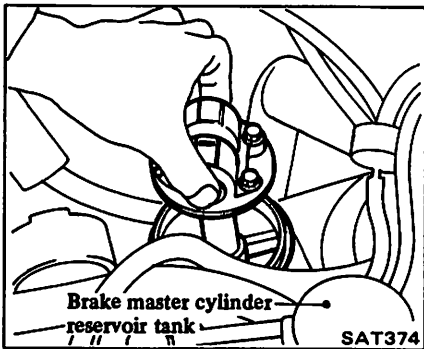

8. Disassemble, check and reassemble governor shaft assembly. Refer to page AT-32 for Governor.

11. Install battery support bracket, battery and radiator reservoir tank.
12. Connect battery terminal.

INHIBITOR SWITCH

1. Remove undercover.
2. Remove control cable end from unit.

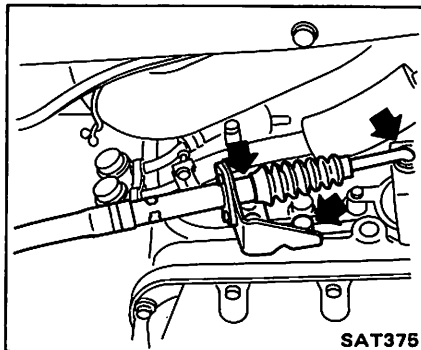

3. Disconnect harness at connector, then remove inhibitor switch.

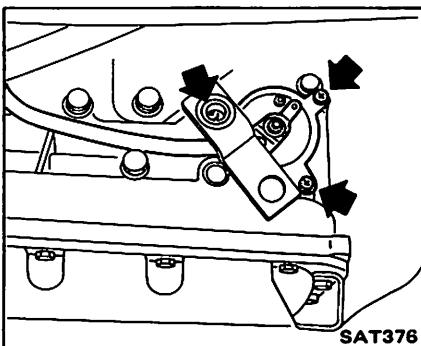

4. Install inhibitor switch in the reverse order of removal.

Ⓙ : 2.0 - 2.5 N·m
(0.20 - 0.25 kg·m,
1.4 - 1.8 ft·lb)

5. Adjust inhibitor switch. Refer to Minor Adjustments.

BEARING RETAINER OIL SEAL

1. Remove left drive shaft assembly. Refer to Drive Shaft for removal.
2. Remove oil seal.

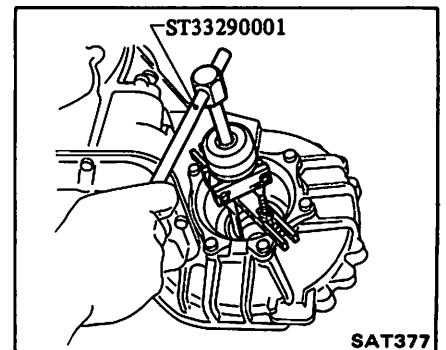

3. Apply coat of automatic transaxle fluid to oil seal surface, then drive new seal into place.

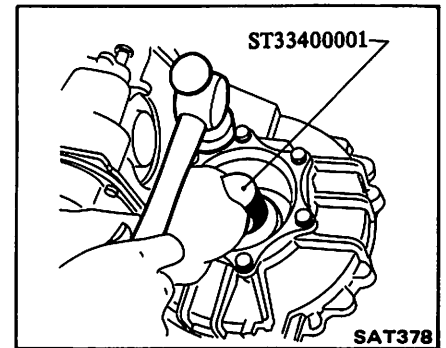

4. Install left drive shaft assembly. Refer to Drive Shaft for installation.

CONVERTER HOUSING OIL SEAL

1. Remove right drive shaft assembly. Refer to Drive Shaft for removal.
2. Remove oil seal.

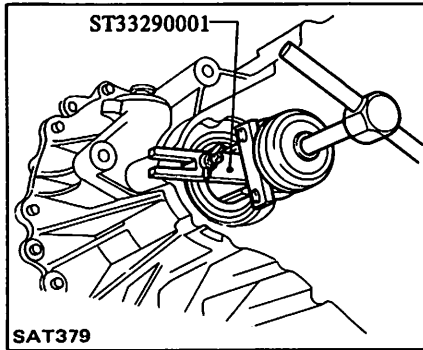

3. Apply coat of automatic transaxle fluid to oil seal surface, then drive new seal into place.

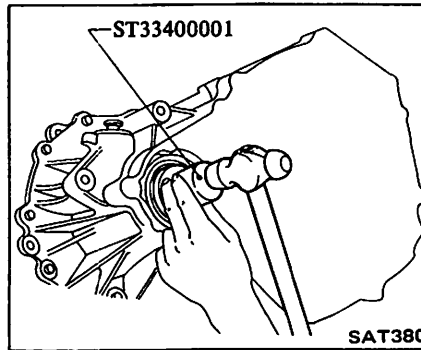

4. Install right drive shaft assembly. Refer to Drive Shaft for installation.

MINOR ADJUSTMENTS

THROTTLE WIRE ADJUSTMENT

Throttle wire is adjusted by means of double nuts on carburetor side.

1. Loosen throttle wire double nuts A and B on carburetor side.

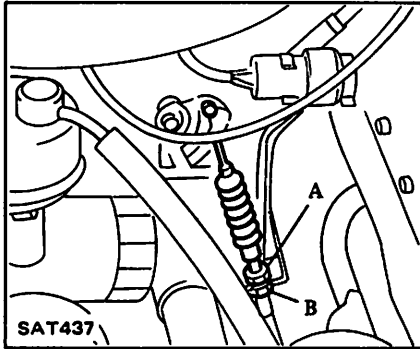

2. With throttle drum set at "P₁" (fully-open), move fitting Q fully in direction T and tighten nut B in direction U.

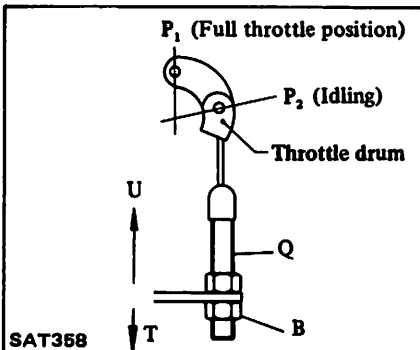

3. Reverse nut B 0.5 revolutions in direction T, then tighten nut A securely. Throttle drum should be held at "P₁".

Ⓣ : Double nuts
8 - 10 N-m
(0.8 - 1.0 kg-m,
5.8 - 7.2 ft-lb)

4. Ensure that throttle wire stroke L is within specified range between full throttle and idle.

Throttle wire stroke:
27.4 - 31.4 mm
(1.079 - 1.236 in)

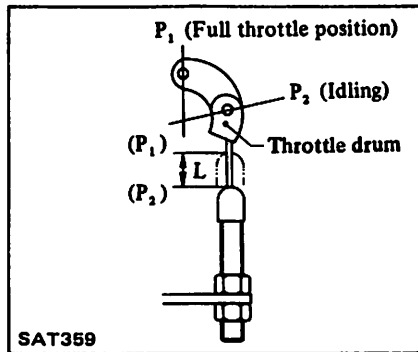

- a. Adjust throttle wire stroke when throttle wire/accelerator wire is installed or after carburetor has been adjusted.
- b. Put marks on throttle wire to facilitate measuring wire stroke.

Problems arising from improper adjustment of throttle wire

If throttle wire stroke is improperly adjusted, the following problems may arise.

- When full-open position "P₁" of throttle drum is closer to direction T, shift schedule will be as shown by ② in figure below, and kick-down range will greatly increase.

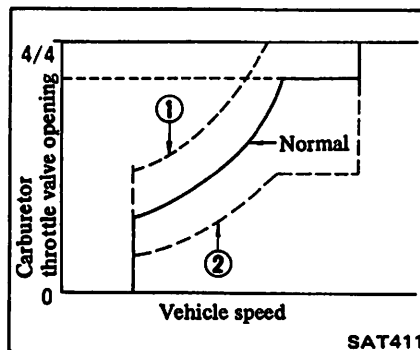

- When full-open position "P₁" of throttle drum is closer to direction U, shift schedule will be as shown by ① in figure above, and kick-down range will not occur.

CONTROL CABLE ADJUSTMENT

Adjustment of the control cable is an important adjustment of the automatic transaxle. Move the shift lever from the "P" range to "1" range. You should be able to feel the detents in each range.

If the detents cannot be felt or the pointer indicating the range is improperly aligned, the control cable needs adjustment.

Control cable adjustment

1. Place control lever at "P" range.
2. Connect control cable end to manual lever in transaxle unit, and tighten control cable securing bolts.

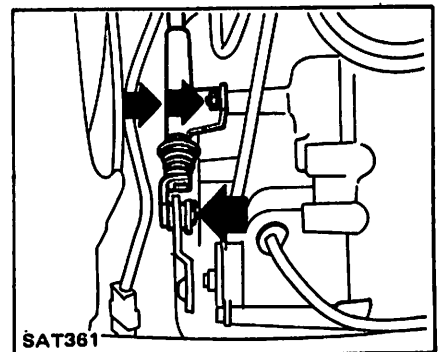

3. Move control lever from "P" range to "1" range. Make sure that control lever can move smoothly and without any sliding noise.
4. Place control lever at "P" range again.
5. Make sure that control lever locks at "P" range.
6. Remove control cable adjusting nut A and loosen nut B, then connect control cable to trunnion. Install nut A and B, then tighten them.

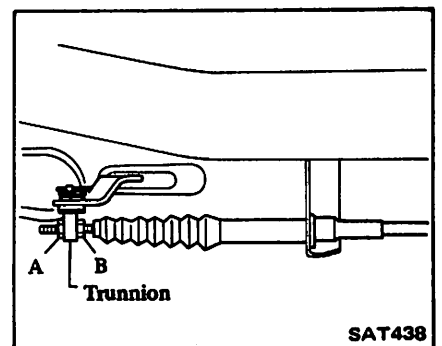

7. Move control lever from “P” range to “1” range again. Make sure that control lever can move smoothly and without any sliding noise.
8. Apply grease to spring washer.

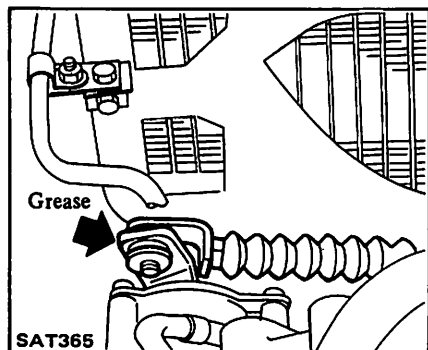

9. After properly adjusting control cable, check spring pin to see if it is assembled as shown in figure below. If not, adjust spring pin.

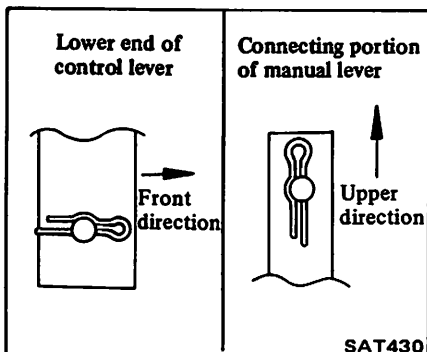

BRAKE BAND ADJUSTMENT

Proper brake band adjustment results in smooth shifting between 1st & 2nd and 2nd & 3rd. Although the adjustment is very simple, it is important to use an accurate torque wrench.

1. Loosen locknut.
2. Torque anchor end pin lock nut to 4 to 6 N·m (0.4 to 0.6 kg-m, 2.9 to 4.3 ft-lb).
3. Back off anchor end pin lock nut 2.5 complete turns.
4. Tighten locknut to 16 to 22 N·m (1.6 to 2.2 kg-m, 12 to 16 ft-lb) while holding anchor end pin lock nut stationary.

INHIBITOR SWITCH ADJUSTMENT

The inhibitor switch has two major functions. It allows the back-up lights to illuminate when the shift lever is placed in the reverse range. It also acts as a neutral safety switch allowing current to pass from the starter only when the lever is placed in the “P” or “N” range.

A continuity tester may be used to check the inhibitor switch for proper operation.

- Check continuity at “N”, “P” and “R” ranges.

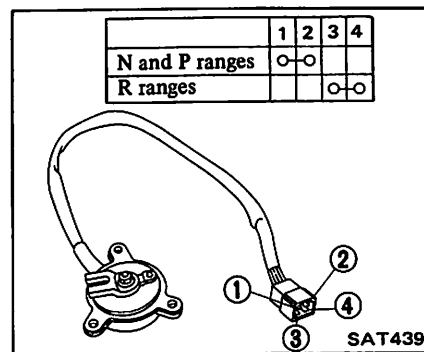

- With control lever held in Neutral, turn manual lever an equal amount in both directions to see if current flow ranges are nearly the same. (Current normally begins to flow before manual lever reaches an angle of 1.5° in either direction.)

If current flows outside normal range, or if normal flow range is out of specifications, properly adjust inhibitor switch.

Adjust inhibitor switch as follows:

This adjustment can be done on the vehicle.

1. Loosen attaching screws.
2. Set select lever (manual shaft) at “N” position.
3. Insert a 2.5 mm (0.098 in) dia. pin into adjustment holes in both inhibitor switch and switch lever as near vertical as possible.

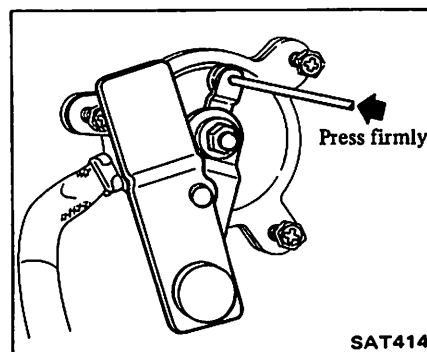

4. Tighten screws.

Ⓣ : 2.0 - 2.5 N·m
(0.20 - 0.26 kg-m,
1.4 - 1.9 ft-lb)

5. Recheck for continuity. If faulty, replace the switch.

REMOVAL AND INSTALLATION

TRANSAXLE ASSEMBLY

When dismantling the automatic transaxle from a vehicle, pay attention to the following points:

1. Before dismantling the transaxle, rigidly inspect it by using the "Trouble-shooting Chart", and dismount it only when it is necessary.
2. Dismount the transaxle with utmost care; and when mounting, observing the tightening torque indicated on another table, do not exert excessive force.

6. Remove undercover.
7. Disconnect speedometer cable.
8. Disconnect throttle wire from carburetor throttle lever.

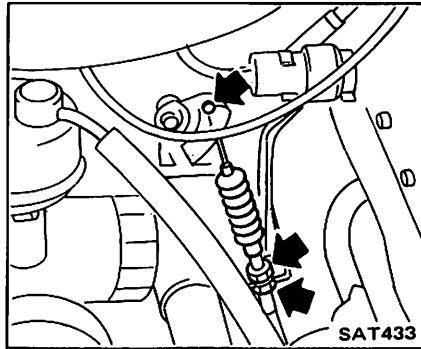

12. Place jack under transaxle and engine.

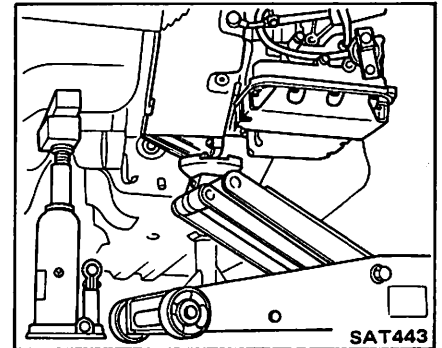

REMOVAL

In dismantling the automatic transaxle from a vehicle, proceed as follows:

1. Disconnect battery ground cable from terminal.
2. Jack up vehicle and support it on safety stands. We recommend a hydraulic hoist or open pit be utilized, if available.
3. Drain oil.

Observe all safety regulations.

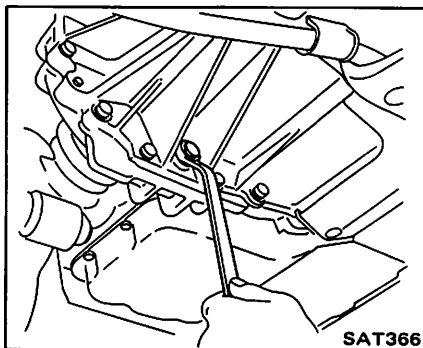

9. Remove control cable rear end from unit.

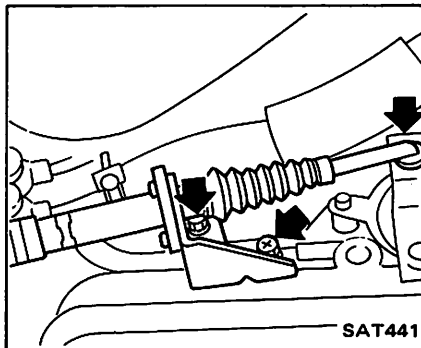

CAUTION:

Do not place the jack under the oil pan drain plug.

10. Remove left side fender protector.
11. Remove front exhaust tube.

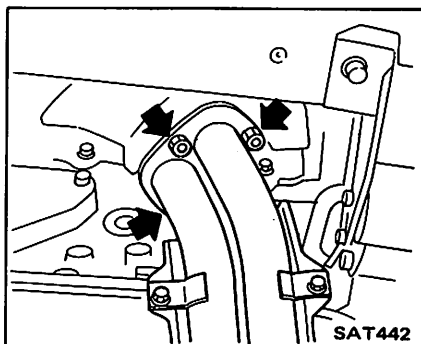

13. Disconnect oil cooler hoses from tubes.

14. Detach converter housing dust cover. Remove bolts securing torque converter to drive plate.

- a. Remove those bolts turning crank shaft.

- b. Before removing torque converter, inscribe chalk marks on two parts so that they may be replaced in their original positions during assembly.

15. Remove engine mount securing bolts.

16. Remove starter motor.

17. Remove bolts securing transaxle to engine. After removing these bolts, move the jack gradually until transaxle can be removed and take out transaxle from left side wheel house.

Plug up openings such as oil charging pipe, oil cooler tubes, etc.

CAUTION:

Take care when dismantling transaxle not to strike any adjacent parts.

4. Disconnect right side drive shaft. Refer to Drive shaft (Section FA) for removal.

5. Remove left side drive shaft together with left side strut assembly.

Refer to Drive Shaft and Strut (Section FA) for removal.

INSTALLATION

Installation of automatic transaxle on vehicle is in reverse order of removal. However, observe the following installation notes.

1. Drive plate runout

Turn crankshaft one full turn and measure drive plate runout with indicating finger of a dial gauge rested against plate.

**Maximum allowable runout:
0.5 mm (0.020 in)**

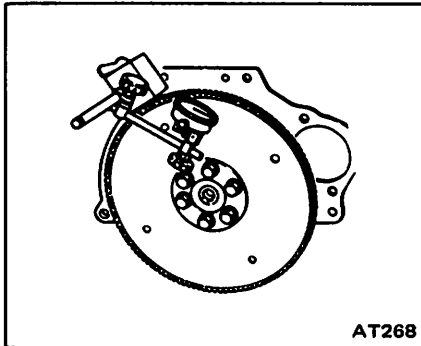

2. When connecting torque converter to transaxle, measure distance "A" to be certain that they are correctly assembled.

**Distance "A":
More than 21.1 mm (0.831 in)**

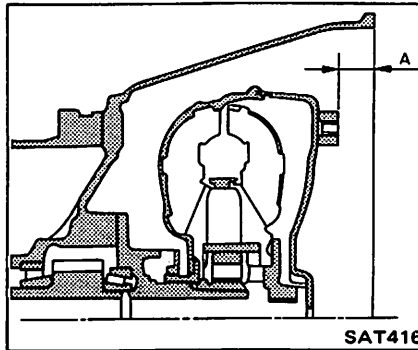

3. Bolt converter to drive plate.

- a. Align chalk marks painted across both parts during disassembly.
- b. Before installing torque converter securing bolts, apply locking sealer to threads of bolts.

4. After converter is installed, rotate crankshaft several turns and check to be sure that transaxle rotates freely without binding.

5. Pour recommended automatic transaxle fluid up to correct level through oil charge pipe.

6. Connect control cable to manual shaft. Adjust control cable. Refer to Minor Adjustments.

7. Connect inhibitor switch wires.

a. Refer to page AT-12 for Inhibitor Switch Adjustment.

b. Inspect and adjust switch as above whenever it has to be removed for service.

8. Check inhibitor switch for operation:

Starter should be brought into operation only when selector lever is in "P" and "N" positions (it should not be started when lever is in "D", "2", "1" and "R" positions).

Back-up lamp should also light when selector lever is placed in "R" position.

9. Check fluid level in transaxle. For detailed procedure, see page AT-42.

10. Move hand lever through all positions to be sure that transaxle operates correctly.

With hand brake applied, rotate engine at idling. Without disturbing the above setting, move selector lever through "N" to "D", to "2", to "1" and to "R". A slight shock should be felt by hand gripping hand lever each time transaxle is shifted.

See page AT-43 for Checking Engine idle.

11. Check to be sure that line pressure is correct. To do this, refer to page AT-45 for Line Pressure Test.

12. Perform stall test as described in page AT-45.

MAJOR OVERHAUL OPERATIONS

Tightening torque N·m (kg·m, ft·lb)

- (A) 49 - 69 (5.0 - 7.0, 36 - 51)
- (B) 14 - 18 (1.4 - 1.8, 10 - 13)
- (C) 29 - 49 (3.0 - 5.0, 22 - 36)
- (D) 2.0 - 2.5 (0.20 - 0.26, 1.4 - 1.9)
- (E) 5 - 7 (0.5 - 0.7, 3.6 - 5.1)
- (F) 7 - 9 (0.7 - 0.9, 5.1 - 6.5)
- (G) 25 - 31 (2.6 - 3.2, 19 - 23)
- (H) 19 - 25 (1.9 - 2.5, 14 - 18)
- (I) 4 - 5 (0.4 - 0.5, 2.9 - 3.6)
- (J) 5 - 7 (0.5 - 0.7, 3.6 - 5.1)
- (K) 4 - 5 (0.4 - 0.5, 2.9 - 3.6)
- (L) 3.4 - 6.9 (0.35 - 0.7, 2.5 - 5.1)
- (M) 5 - 7 (0.5 - 0.7, 3.6 - 5.1)
- (N) 69 - 78 (7.0 - 8.0, 51 - 58)
- (O) 7 - 9 (0.7 - 0.9, 5.1 - 6.5)
- (P) 14 - 18 (1.4 - 1.8, 10 - 13)

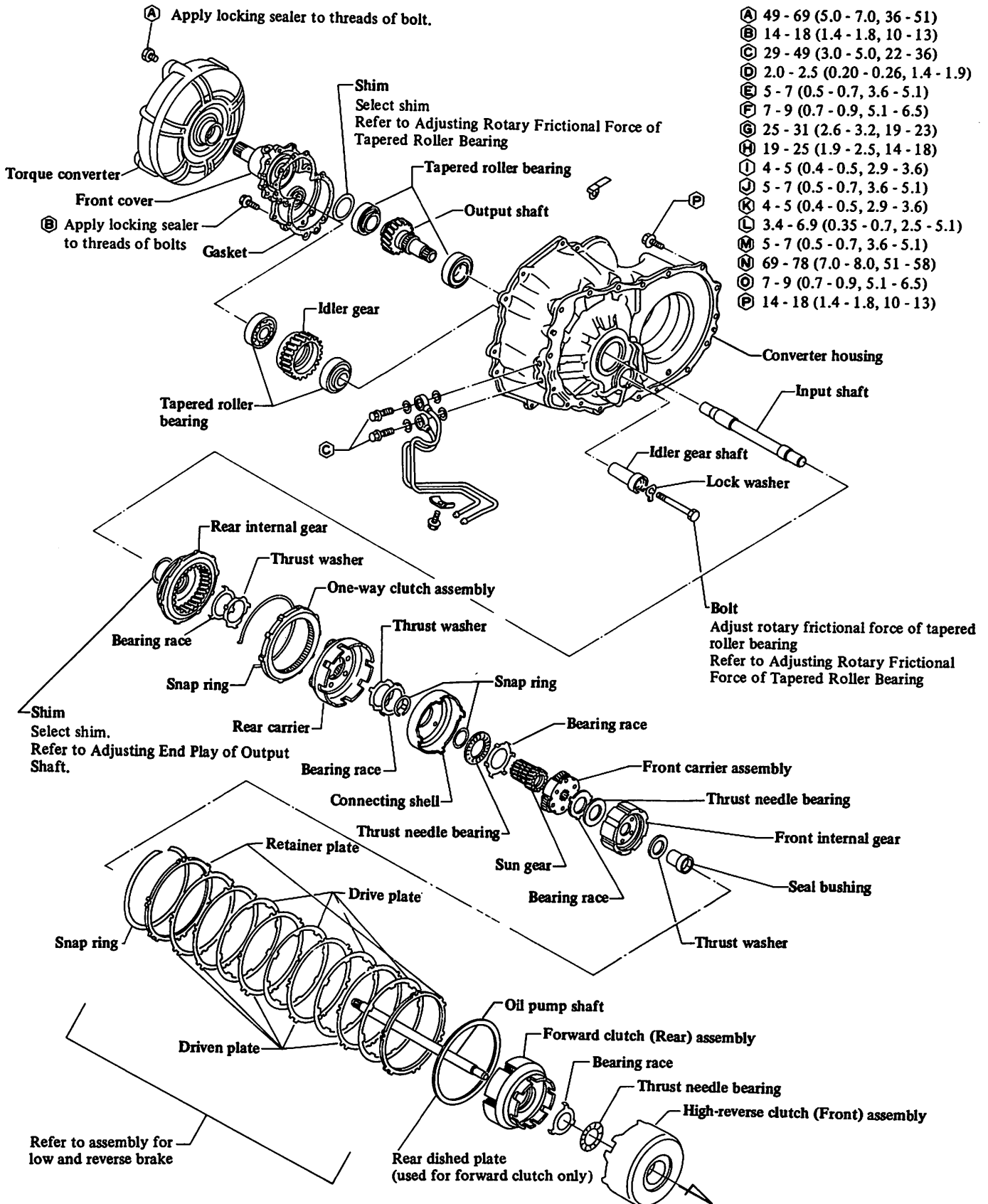

SERVICE NOTES FOR DISASSEMBLY

Before proceeding with disassembly, thoroughly clean the outside of the transaxle. It is important to prevent the internal parts of the transaxle from becoming contaminated by dirt or other foreign matter.

Disassembly should be done in a clean work area.

Use a nylon cloth or paper towel for wiping parts clean. Common shop rags can leave lint that might interfere with the transaxle's operation.

DISASSEMBLY

1. Remove hexagon plug, then drain transaxle fluid from plug hole.
2. Remove torque converter.

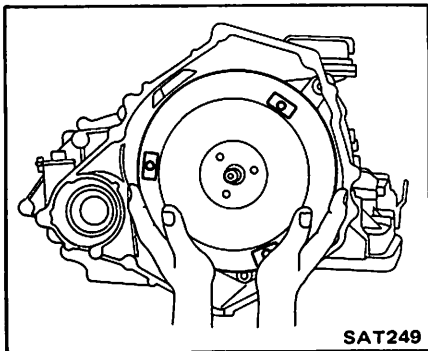

3. Remove oil pump shaft and input shaft.

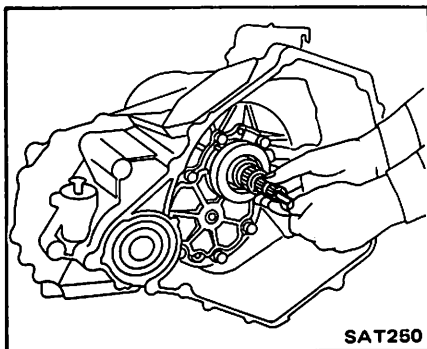

4. Remove snap retainer, governor cap with breather hose and O-ring.

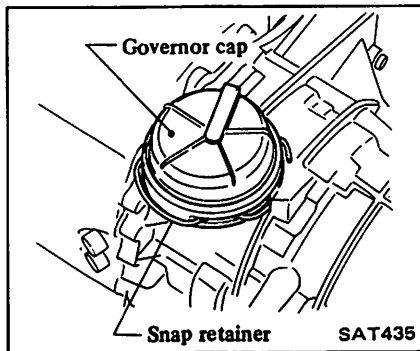

5. Remove oil pan guard and oil pan and inspect its contents. An analysis of any foreign matter can indicate the types of problems to look for. If the fluid is very dark, smells burned, or contains foreign particles, the frictional material (clutches, band) may need replacement. A tacky film that will not wipe clean indicates varnish build up which can cause valves, servo, and clutches to stick and may inhibit pump pressure.

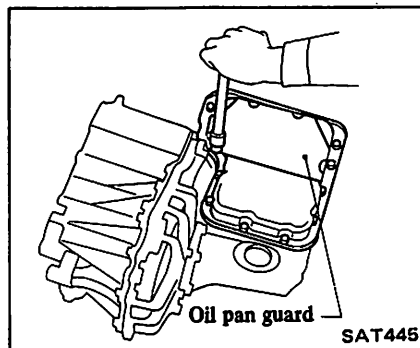

6. Remove control valve body and magnet.

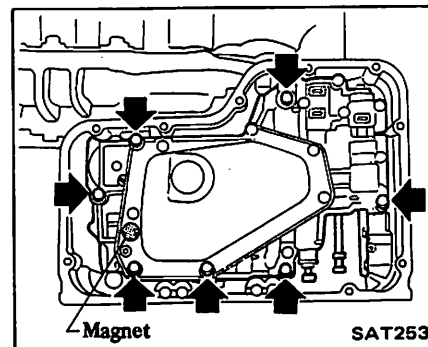

Remove manual valve from valve body as a precaution, to prevent valve from dropping out accidentally.

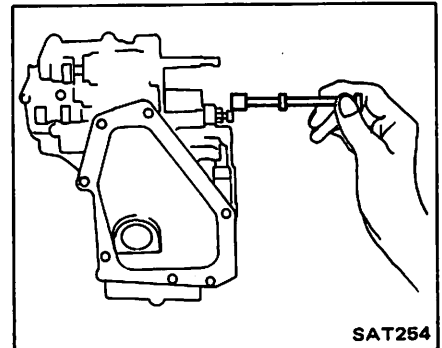

7. Remove manual shaft securing nuts.

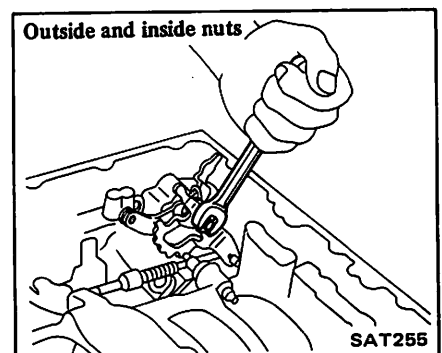

8. Pull out retaining pin, then remove throttle lever, manual plate, manual shaft, selector range lever and parking rod assembly.

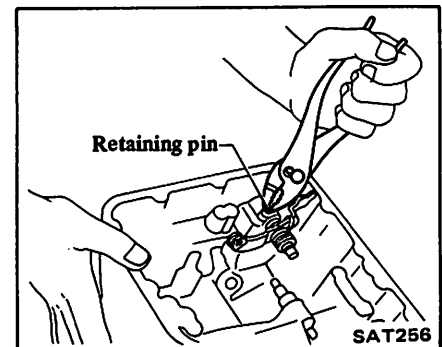

9. Disconnect throttle wire from throttle lever, then remove throttle wire. Remove parking actuator support from transmission case.

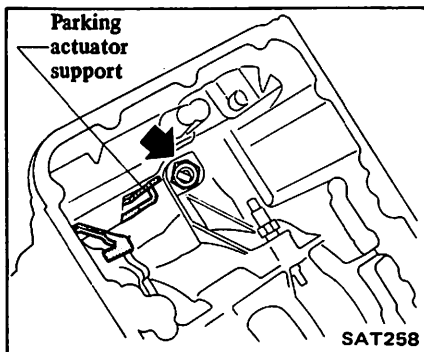

12. Remove converter housing securing bolts.

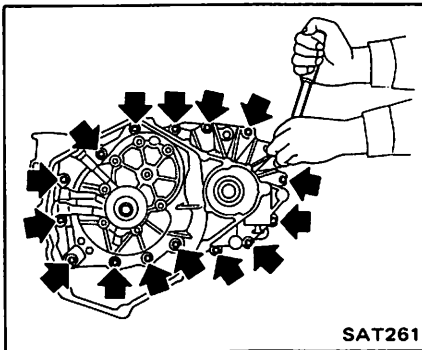

16. Straighten lock washer.

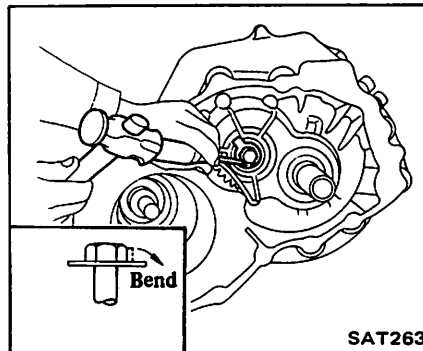

10. Loosen band brake piston stem lock nut, then back off piston stem.

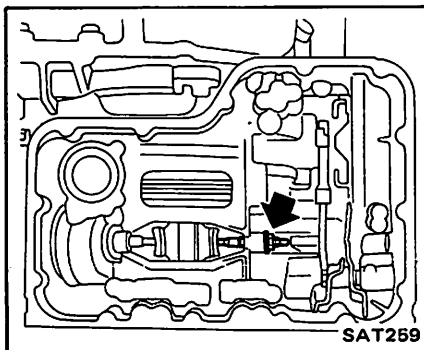

13. Separate converter housing from transmission case by tapping it.

Be careful not to drop final drive assembly.

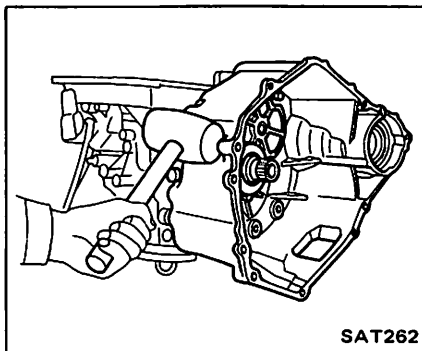

17. Remove idler gear bolt and lock washer.

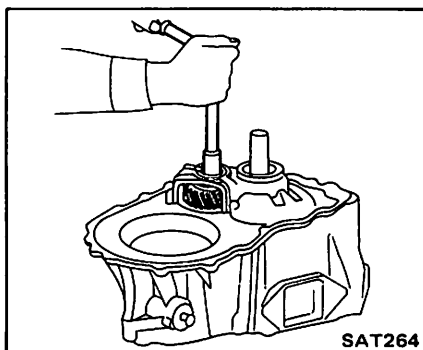

11. Remove accumulator piston with compressed air.

Be careful that accumulator piston does not jump out.

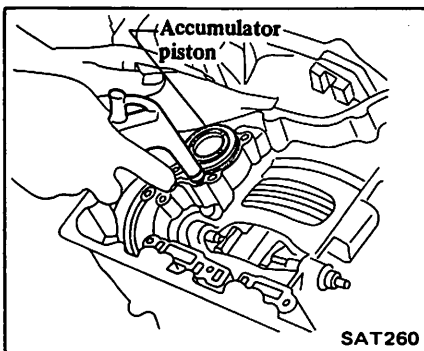

14. Remove final drive assembly.

15. Pull out parking pawl shaft, then remove parking pawl and return spring.

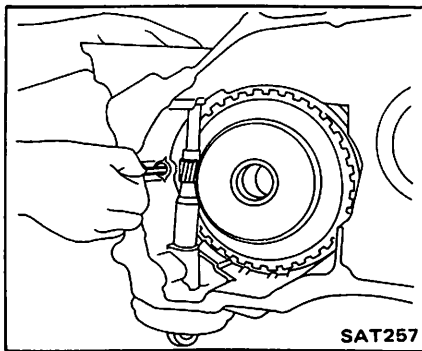

18. Remove front cover retaining bolts.

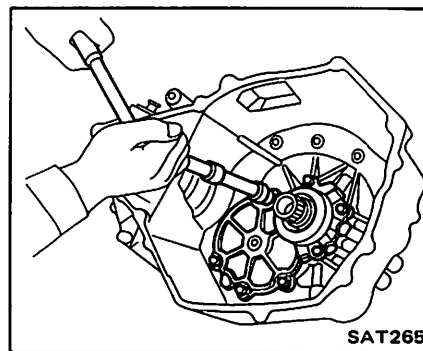

19. Tap output shaft, then remove it together with front cover.

- a. When tapping output shaft, be sure to hold front cover so that it does not fall.
- b. Adjusting shim is attached to rear internal gear side of output shaft so be careful not to lose it.

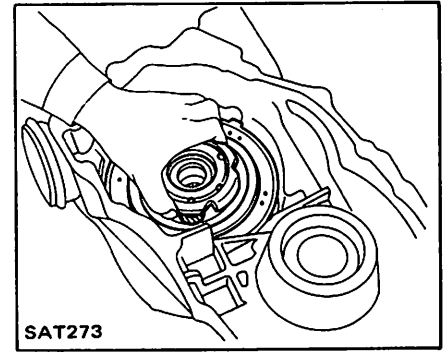
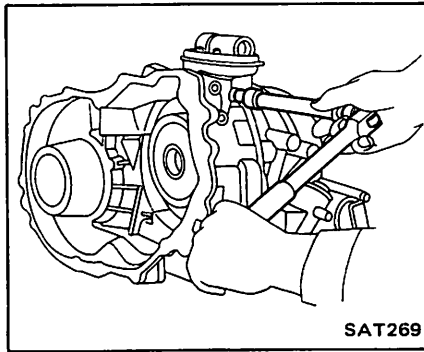
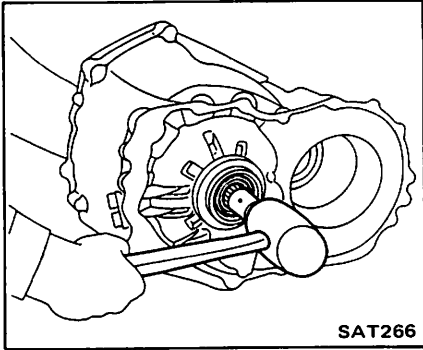

20. Remove front cover gasket.

21. Remove idler gear, idler gear shaft and taper roller bearings by tapping idler gear shaft.

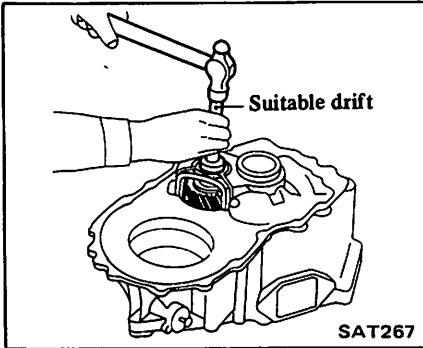

24. Pull out governor shaft.

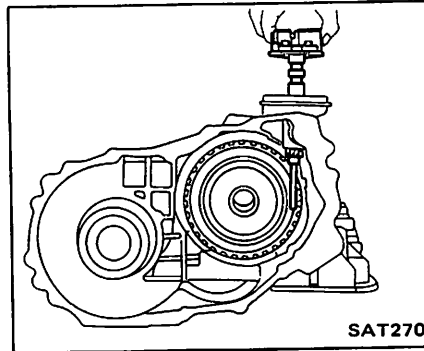

28. Remove bearing race and thrust washer.

29. Remove low and reverse brake snap ring.

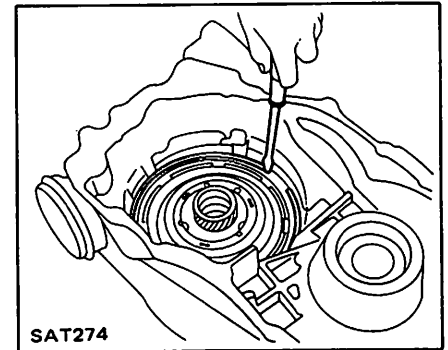

25. Remove rear internal gear, bearing race and thrust washer.

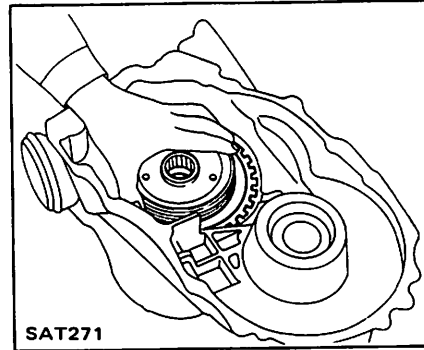

30. Remove shell & sun gear assembly, thrust needle bearing and bearing race.

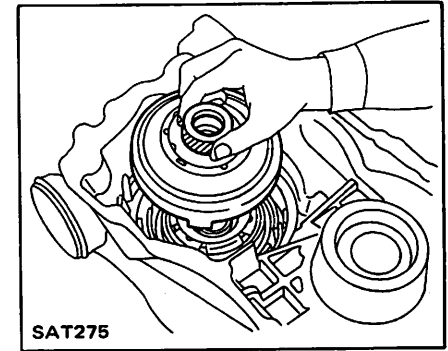

22. Remove seal bushing.

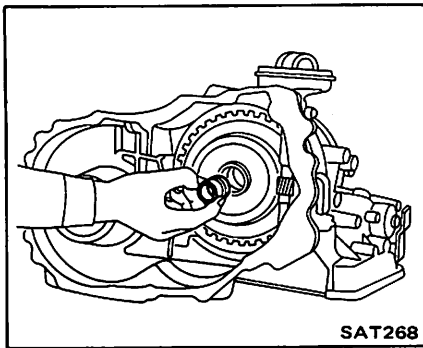

26. Remove one-way clutch snap ring.

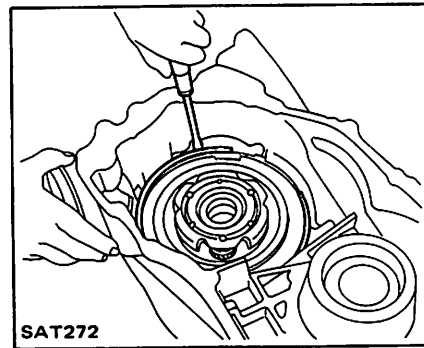

31. Remove front carrier assembly together with front internal gear.

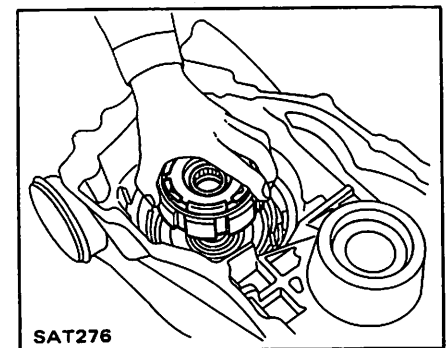

23. Remove governor shaft retaining bolt.

27. Remove one-way clutch assembly together with rear carrier assembly.

32. Remove forward clutch (Rear) assembly and plastic thrust washer.

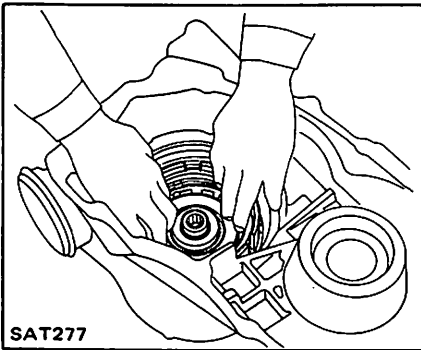

33. Remove low and reverse brake retaining plate, driven plates and drive plates at the same time.

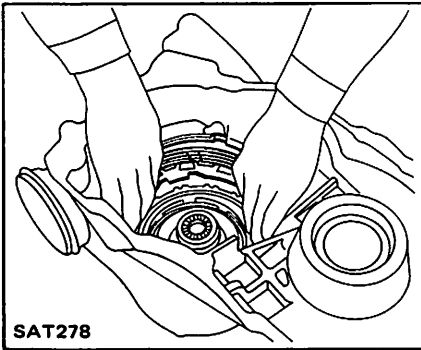

34. Remove high-reverse clutch (Front) assembly by turning it.

Check seal rings to ensure that they have not expanded. If they have, high-reverse clutch (Front) assembly will be hard to remove. If it is forcibly removed, seal rings may be damaged.

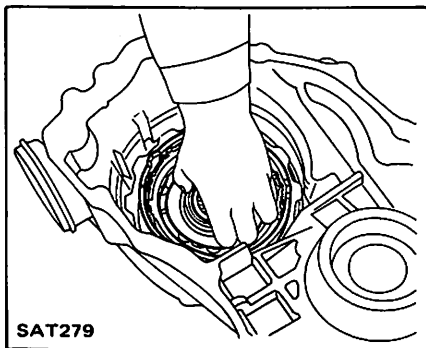

35. Remove brake band.

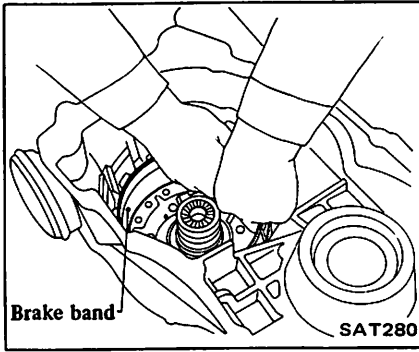

To prevent brake linings from cracking or peeling, do not stretch the flexible band unnecessarily. Before removing the brake band, always secure it with a clip as shown in the figure below.

Leave the clip in position after removing the brake band.

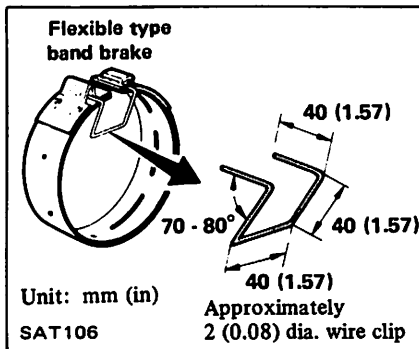

36. Remove low and reverse brake retainer.

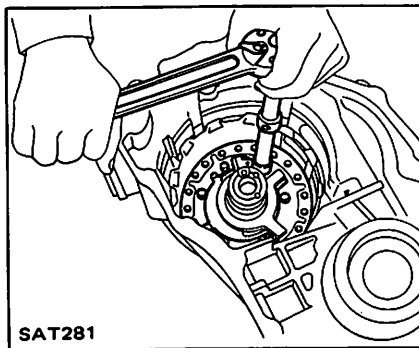

37. Remove low and reverse brake piston with compressed air.

Be sure to hold low and reverse brake piston with nylon cloth so that they do not jump out.

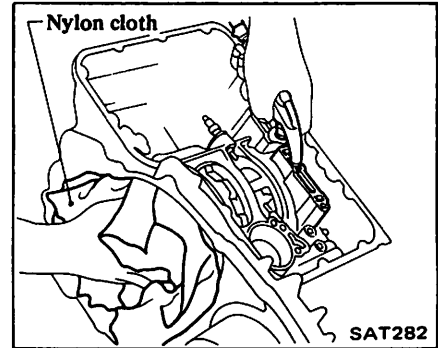

If compressed air is not available, remove it with a screwdriver.

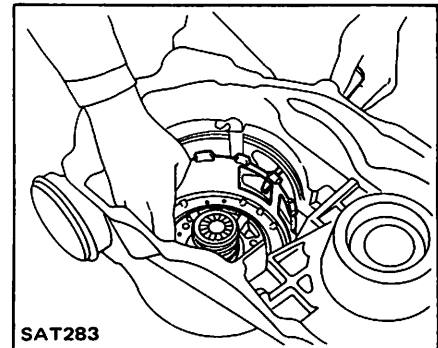

38. Remove oil pump assembly, thrust washer and thrust needle bearing.

The oil pump and transmission case fit loosely, but the clearance is very small. So always lift it straight out of transmission case.

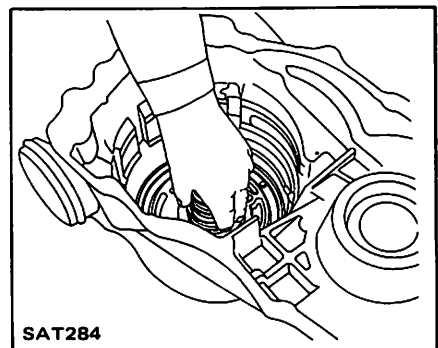

39. Remove inhibitor switch.

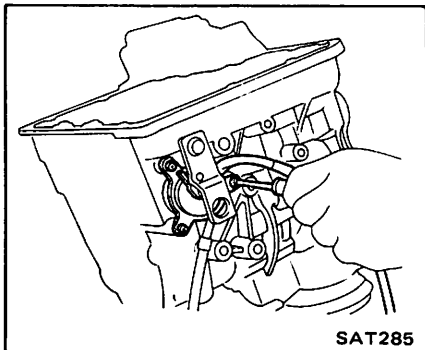

40. Remove band servo piston and return spring. Then, transmission case can be removed.

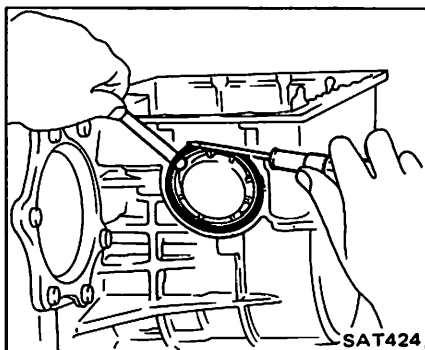

COMPONENT PARTS

The transaxle consists of many small parts that are quite alike in construction yet machined to very close tolerances. When disassembling parts, be sure to place them in order in parts rack so they can be put back in the unit in their proper positions. All parts should be carefully cleaned with a general purpose, non-flammable solvent before inspection or reassembly. Gaskets, seals, and similar parts should be replaced. It is also very important to perform functional tests whenever it is designated.

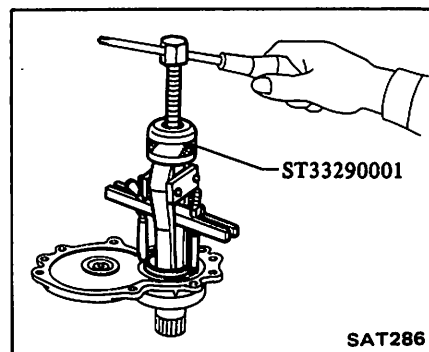

When Tool is to be used, cut toe-tips of two legs with a grinding wheel.

2. Install outer race.

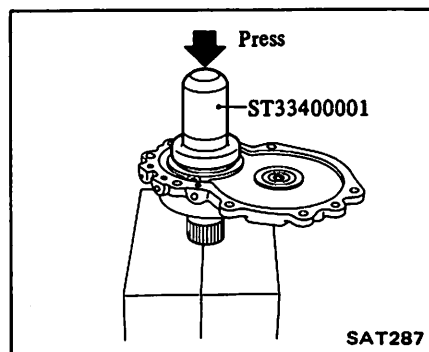

FRONT COVER

1. Remove taper roller bearing outer race.

OIL PUMP

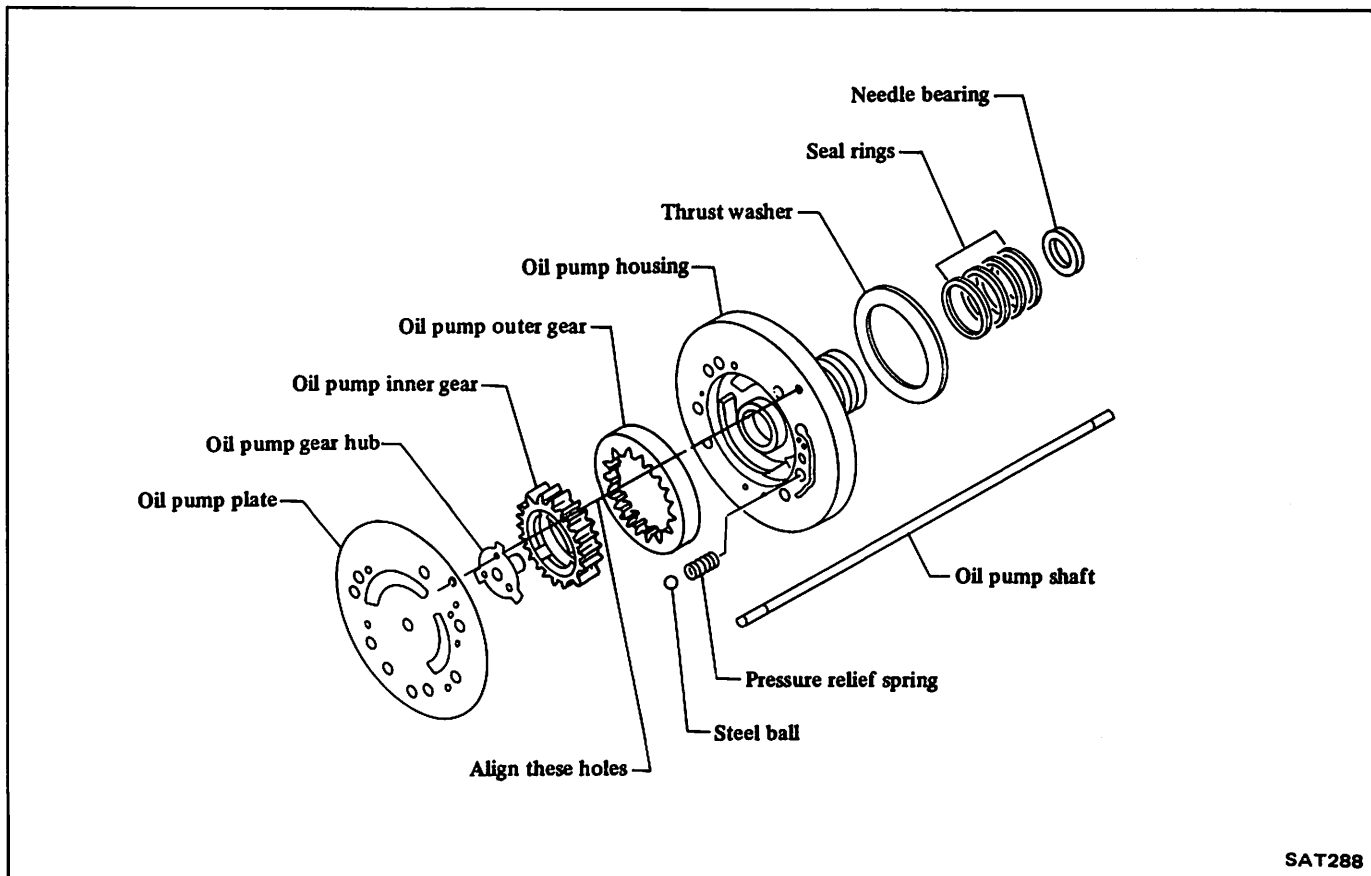

Major Overhaul Operations – AUTOMATIC TRANSAXLE

1. Inspect oil pump body, oil pump shaft and ring groove areas for wear.

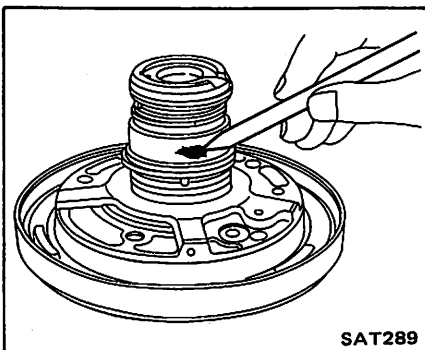

2. Remove oil pump plate.

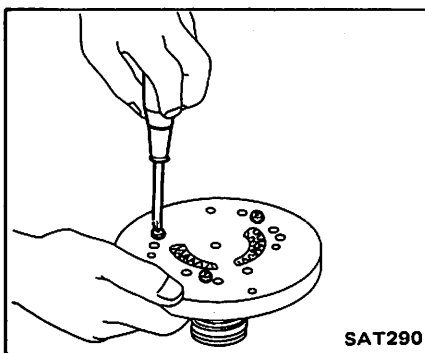

3. Inspect gears and all internal surfaces for faults and visible wear.
4. Measure clearance between outer gear and crescent.

Standard clearance:
0.14 - 0.21 mm
(0.0055 - 0.0083 in)

Replace if the clearance exceeds
0.25 mm (0.0098 in).

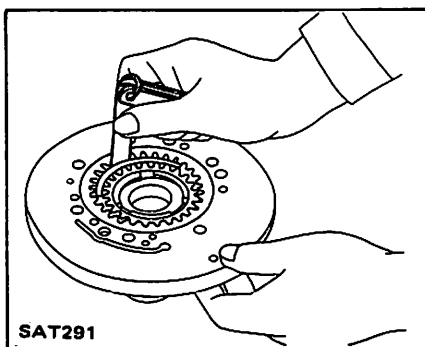

5. Measure clearance between outer gear and pump housing.

Standard clearance:
0.05 - 0.20 mm
(0.0020 - 0.0079 in)

Replace if the clearance exceeds
0.25 mm (0.0098 in).

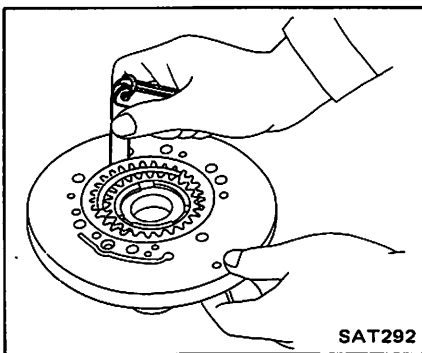

6. Using a feeler gauge and straight edge, measure clearance between gears and pump plate.

Standard clearance:
0.02 - 0.04 mm
(0.0008 - 0.0016 in)

Replace if the clearance exceeds
0.08 mm (0.0031 in).

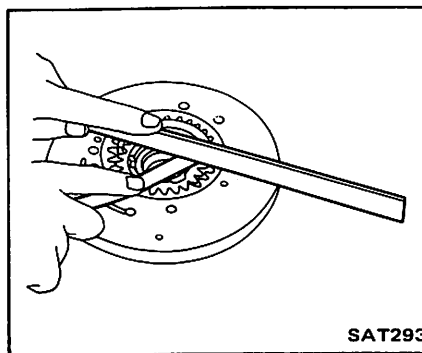

7. Measure clearance between seal ring and ring groove.

Standard clearance:
0.15 - 0.25 mm
(0.0059 - 0.0098 in)

Replace if the clearance exceeds
0.25 mm (0.0098 in).

Of course, it is good practice to re-
place all seal rings during an overhaul.

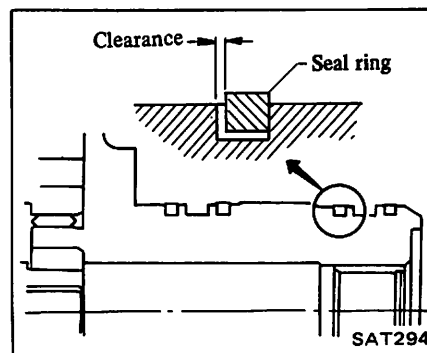

8. Install oil pump gear hub, pressure relief spring and steel ball onto oil pump housing.

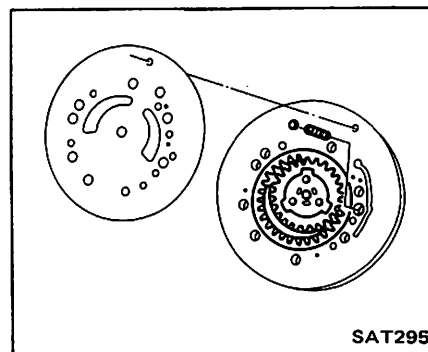

9. Install oil pump plate.

Do not allow periphery of oil pump plate to protrude beyond periphery of oil pump housing.

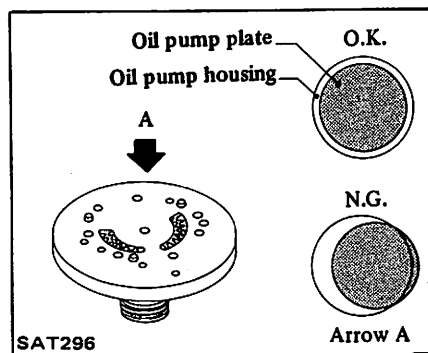

10. Install seal rings.

Refer to the following figure for proper locations of the two different types of seal rings.

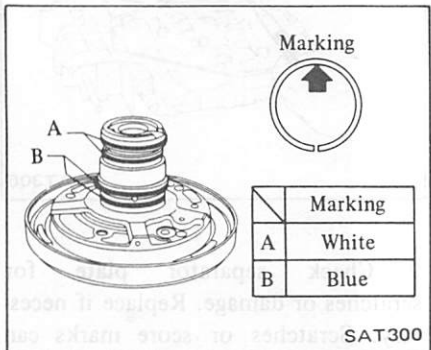

CONTROL VALVE BODY

The valve body contains many precision parts and requires extreme care when parts are removed and serviced. Place removed parts on a parts rack so they can be put back in the valve body in the same positions and sequences. Care will also prevent springs and small parts from becoming scattered or lost.

1. Remove oil strainer and magnet.

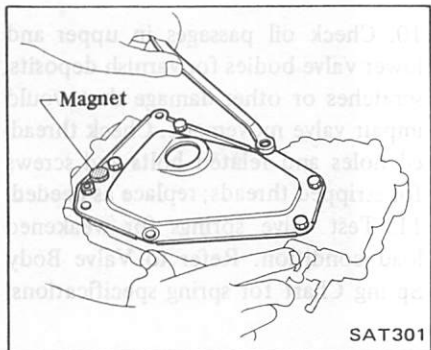

2. Disassemble valve body and its remaining attaching bolts and nuts to carefully separate lower body, separator plate and upper body.

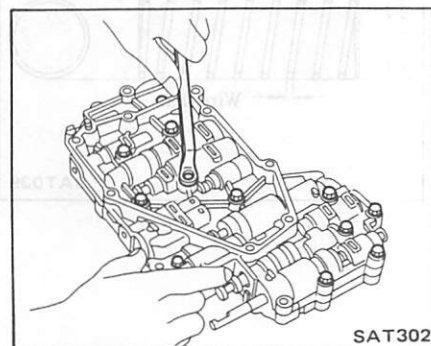

3. During valve body separation, do not lose the 6 steel balls on valve upper body.

4. Remove parallel pins with wire, then remove plugs, 3rd-2nd downshift

valve, 2nd-3rd shift valve, 1st-2nd shift valve, 1st-2nd control valve and their springs.

Place each loose part on a rack to retain correct sequence of assembly.

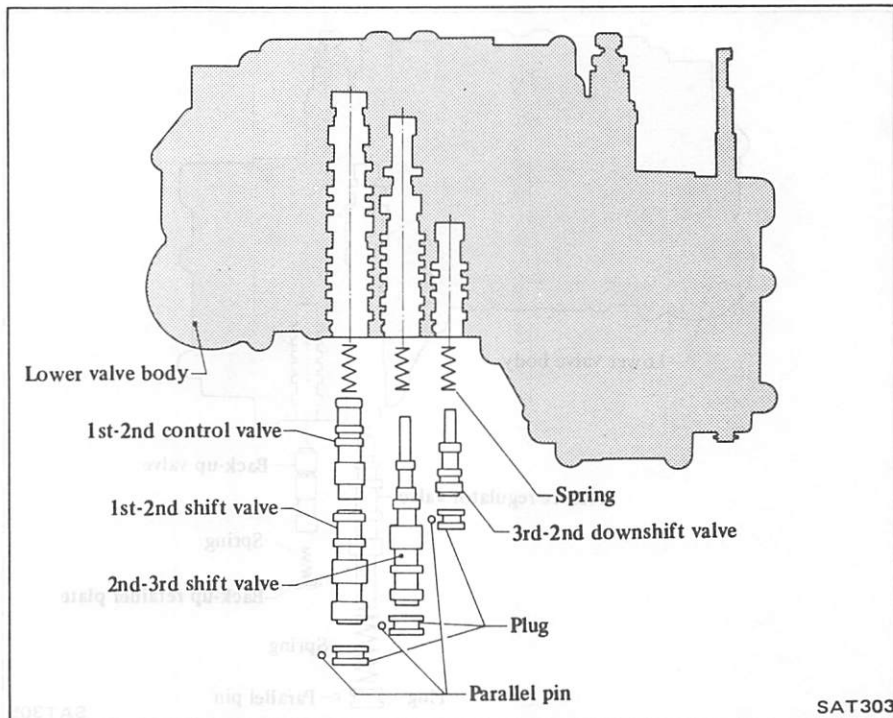

5. Remove parallel pins with wire, then remove plugs, fail-safe valve, throttle valve, detent valve, throttle modulator valve with spring guide, pressure modifier valve, 1st reducing

valve, top reducing valve, 3rd-2nd timing valve and their springs.

Place each loose part on a rack to retain sequence of assembly.

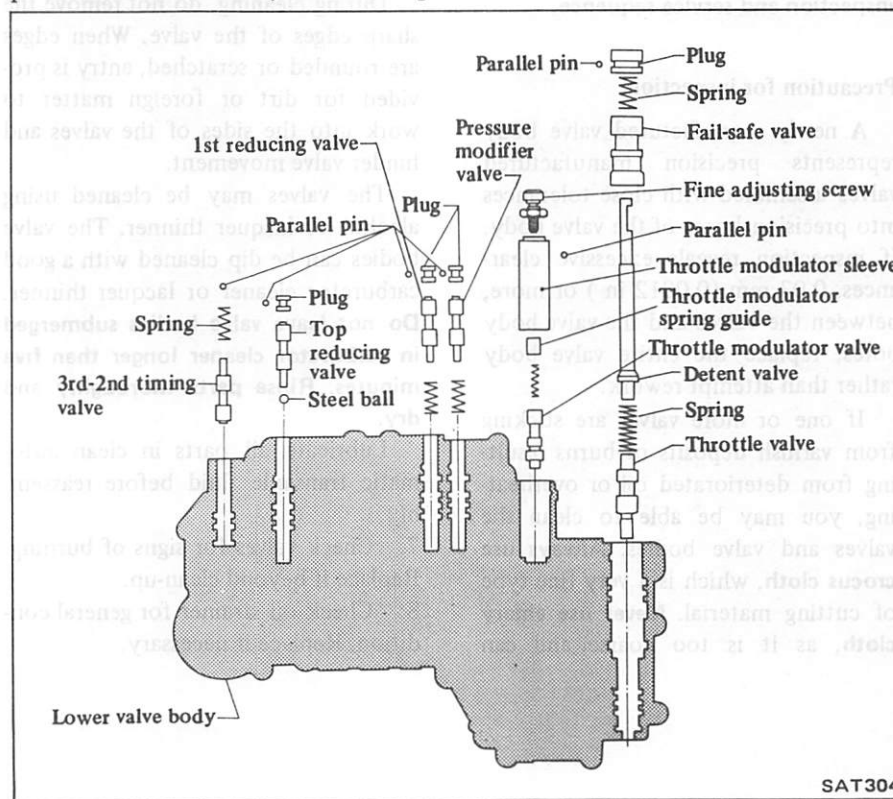

6. Remove back up valve retaining plate by pressing its spring with small screwdriver. Remove parallel pin, then remove plug, pressure regulator valve

and its spring.

Place each loose part on a rack to retain sequence of assembly.

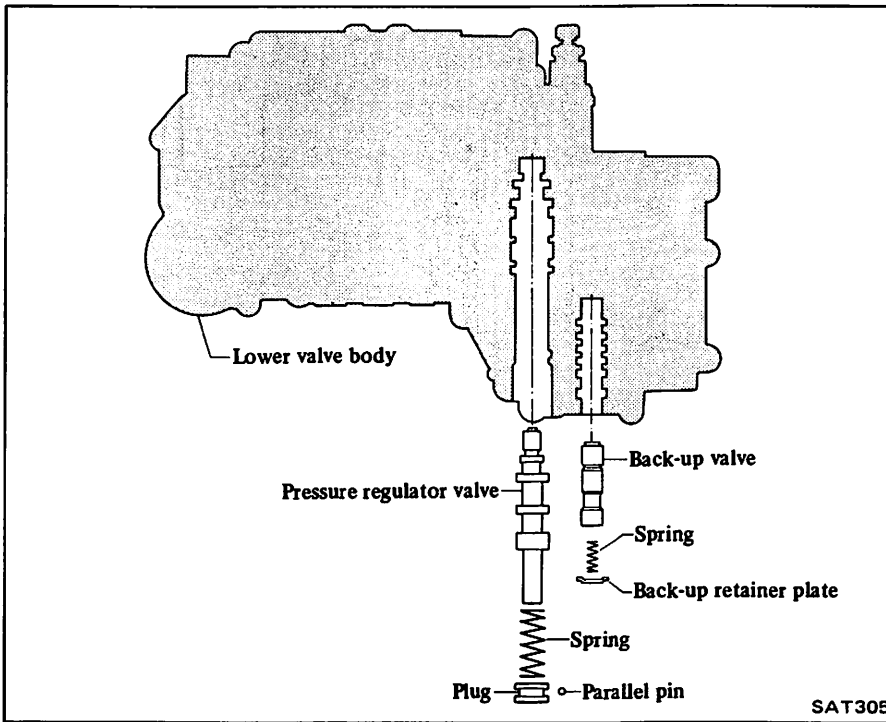

Manual valve was removed when valve body was removed from trans-axle. Include valve in subsequent inspection and service sequence.

Precaution for inspection

A newly manufactured valve body represents precision manufactured valves assembled with close tolerances into precision bores of the valve body. If inspection reveals excessive clearances, 0.03 mm (0.0012 in) or more, between the valves and the valve body bores, replace the entire valve body rather than attempt rework.

If one or more valves are sticking from varnish deposits or burns resulting from deteriorated oil or overheating, you may be able to clean the valves and valve bodies. Always use **crocus cloth**, which is a very fine type of cutting material. Never use **emery cloth**, as it is too coarse and can

scratch the valves or valve bores. Scratches can lead to future deposits of varnish or foreign matter.

During cleaning, do not remove the sharp edges of the valve. When edges are rounded or scratched, entry is provided for dirt or foreign matter to work into the sides of the valves and hinder valve movement.

The valves may be cleaned using alcohol or lacquer thinner. The valve bodies can be dip cleaned with a good carburetor cleaner or lacquer thinner. Do not leave valve bodies submerged in carburetor cleaner longer than five minutes. Rinse parts thoroughly and dry.

Lubricate all parts in clean automatic transaxle fluid before reassembly.

7. Check valves for signs of burning. Replace if beyond clean-up.

8. Check oil strainer for general condition. Replace if necessary.

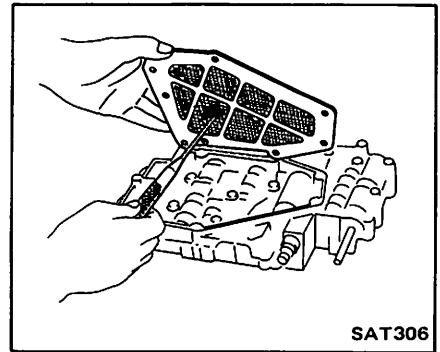

9. Check separator plate for scratches or damage. Replace if necessary. Scratches or score marks can cause oil to bypass correct oil passages and result in system malfunction.

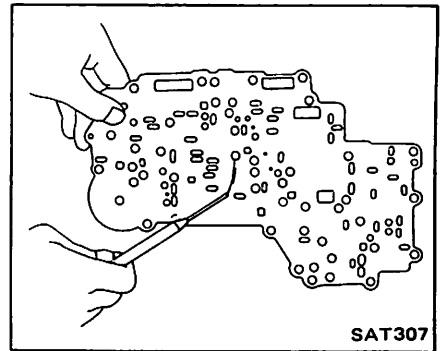

10. Check oil passages in upper and lower valve bodies for varnish deposits, scratches or other damage that would impair valve movement. Check threaded holes and related bolts and screws for stripped threads; replace as needed.
11. Test valve springs for weakened load condition. Refer to Valve Body Spring Chart for spring specifications.

Valve body spring chart

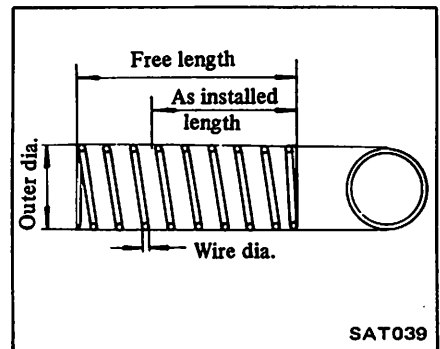

AUTOMATIC TRANSAXLE – Major Overhaul Operations

Valve spring	Wire dia. mm (in)	Outer coil dia. mm (in)	No. of active coils	Free length mm (in)	Installed	
					Length mm (in)	Load N (kg, lb)
Manual detent	1.2 (0.047)	7.2 (0.283)	16	31.9 (1.256)	25 (0.98)	37.76 (3.85, 8.49)
Pressure regulator valve	1.4 (0.055)	15.4 (0.606)	10	60.0 (2.362)	29.5 (1.161)	43.35 (4.42, 9.75)
Throttle valve	1.0 (0.039)	10.0 (0.394)	9.4	32.3 (1.272)	29.3 (1.154)	4.71 (0.48, 1.06)
Fail-safe valve	0.6 (0.024)	10.6 (0.417)	6.5	23.1 (0.909)	8.5 (0.335)	2.9 (0.3, 0.7)
Throttle modulator valve	0.6 (0.024)	5.1 (0.201)	10.5	22.5 (0.886)	20.5 (0.807)	2.9 (0.3, 0.7)
Pressure modifier valve	0.8 (0.031)	7.8 (0.307)	9	25.3 (0.996)	13.0 (0.512)	17.46 (1.78, 3.92)
	0.8 (0.031)	7.8 (0.307)	9	23.6 (0.929)	13.0 (0.512)	15.00 (1.53, 3.37)
	0.8 (0.031)	7.8 (0.307)	9	21.8 (0.858)	13.0 (0.512)	12.55 (1.28, 2.82)
1st reducing valve	0.75 (0.0295)	6.75 (0.2657)	9	21.4 (0.843)	13.0 (0.512)	14.81 (1.51, 3.33)
3rd-2nd timing valve	0.75 (0.0295)	6.75 (0.2657)	9	20.6 (0.8110)	13.0 (0.512)	12.36 (1.26, 2.78)
Back up valve	0.5 (0.020)	5.5 (0.217)	7	18.8 (0.740)	12.0 (0.472)	4.9 (0.5, 1.1)
1st-2nd shift valve	0.65 (0.0256)	6.65 (0.2618)	16	37.3 (1.469)	18.0 (0.709)	10.8 (1.1, 2.4)
2nd-3rd shift valve	0.8 (0.031)	7.8 (0.307)	17	45.4 (1.787)	22.5 (0.886)	17.26 (1.76, 3.88)
3rd-2nd downshift valve	0.65 (0.0256)	7.65 (0.3012)	11	32.6 (1.283)	18.0 (0.709)	6.9 (0.7, 1.5)

Ensure that the new pressure modifier valve spring is the same type as the one which was removed.

12. Assemble all parts into lower valve body in the reverse order of disassembly.

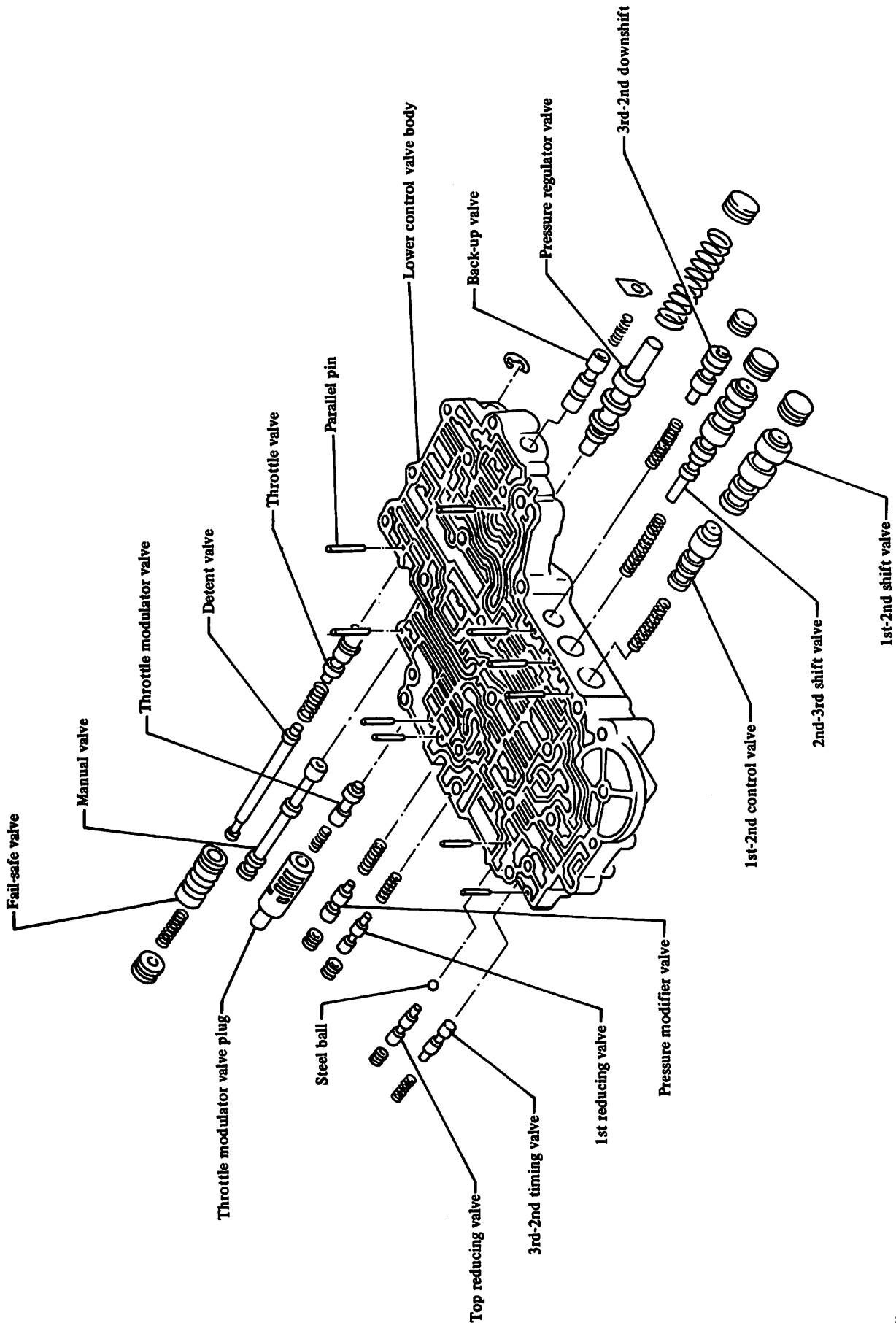

13. Reinstall the six steel balls in upper valve body.

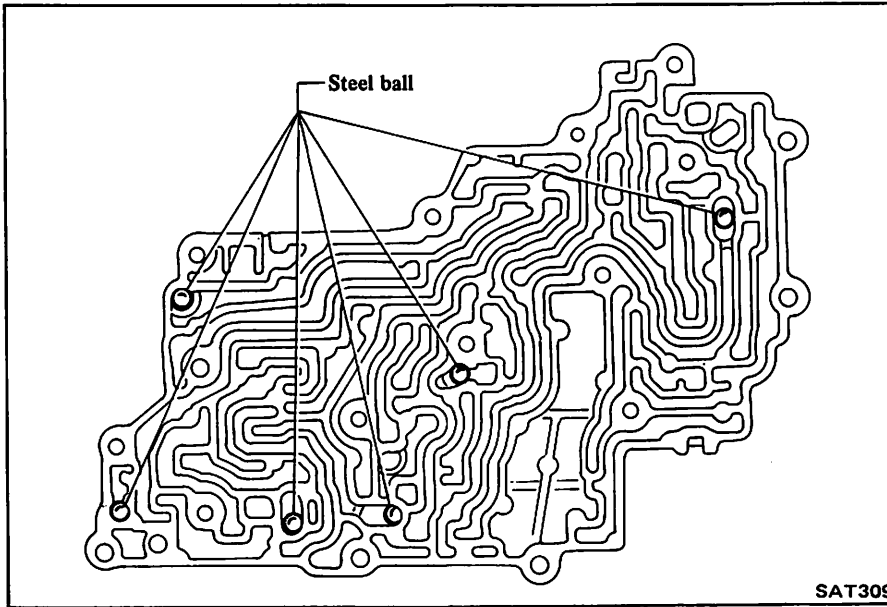

14. Assemble separator plate and lower valve body on upper valve body, then tighten bolts.

When installing these bolts, first be sure to install the two reamer bolts to their original positions.

Ⓣ : Lower valve body to upper valve body securing bolts:
 7 - 9 N·m
 (0.7 - 0.9 kg-m,
 5.1 - 6.5 ft-lb)

Accumulator support plate securing bolt:
 3.4 - 4.4 N·m
 (0.35 - 0.45 kg-m,
 2.5 - 3.3 ft-lb)

15. Install oil strainer and magnet.

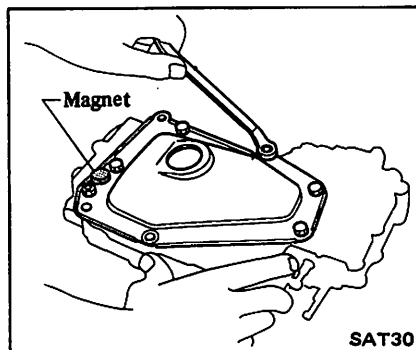

Ⓣ : Oil strainer to valve body
 2.5 - 3.4 N·m
 (0.25 - 0.35 kg-m,
 1.8 - 2.5 ft-lb)

The manual valve is inserted into the valve body when the latter is installed in the transaxle.

Fine adjusting screw

The fine adjusting screw provides a maximum fine adjustment of approximately 5 km/h (3 MPH).

Tightening it causes the shifting point to occur at a lower point, and vice versa, except in the “kickdown” range.

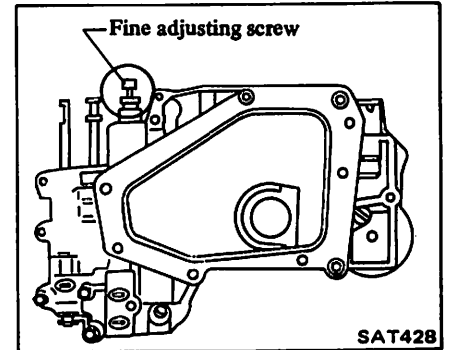

● The standard position of the fine adjusting screw is shown below.

Ⓣ : Lock nut
 3.4 - 4.4 N·m
 (0.35 - 0.45 kg-m,
 2.5 - 3.3 ft-lb)

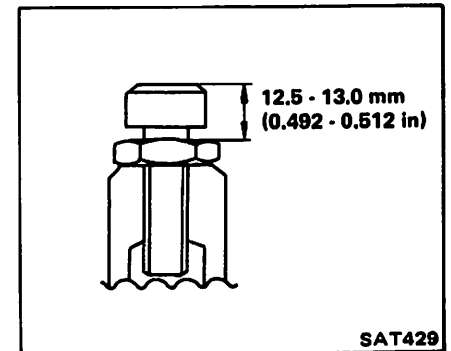

HIGH-REVERSE CLUTCH (Front)

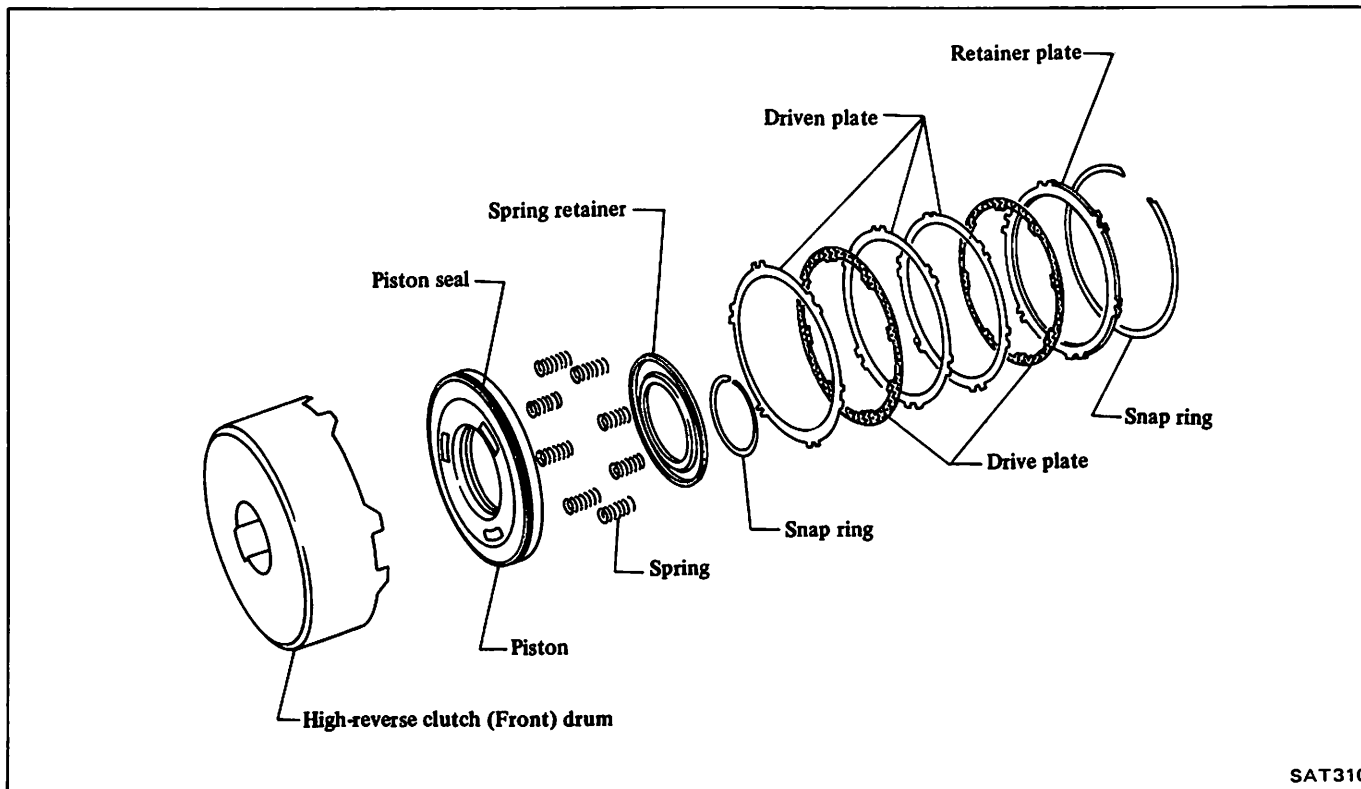

SAT310

1. Using a screwdriver, remove large clutch retaining plate snap ring.

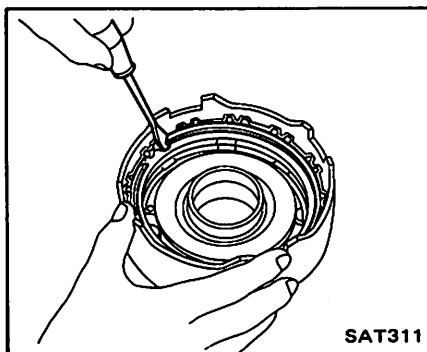

SAT311

3. Compress clutch springs and remove snap ring from spring retainer.

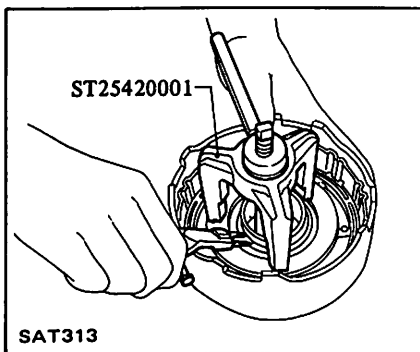

SAT313

5. For easy removal of piston from drum, use an air gun with a tapered rubber tip to carefully apply air pressure to loosen piston from drum.

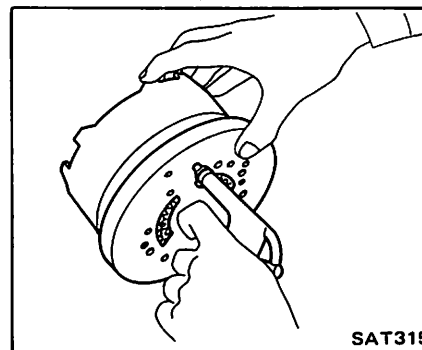

SAT315

2. Remove clutch plates assembly.

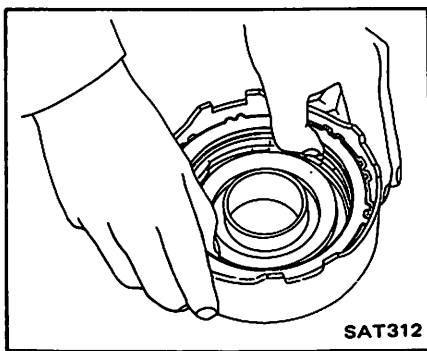

SAT312

4. Remove spring retainer and springs.

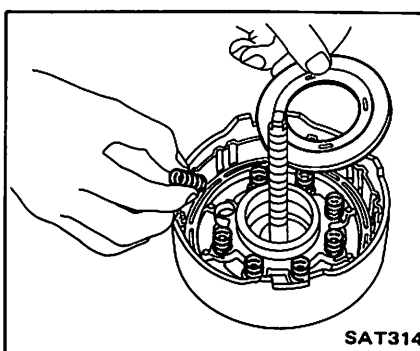

SAT314

6. Check clutch drive plate facing for wear or damage. Drive plate thickness must not be less than 1.4 mm (0.055 in).

**Standard drive plate thickness:
1.50 - 1.65 mm
(0.0591 - 0.0650 in)**

7. Check for wear on snap ring, weak or broken coil springs, and warped spring retainer.

8. Lubricate clutch drum bushing, and install inner seal and piston seal as illustrated. *Be careful not to stretch seals during installation.*

- a. Never assemble clutch dry; always lubricate its components thoroughly.
- b. Always install piston seal in direction shown in figure below.

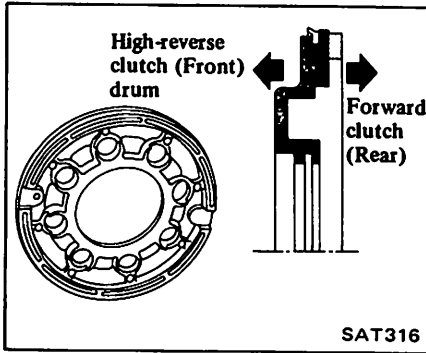

9. Assemble piston, being careful not to allow seal to kink or become damaged during installation. After installing, turn piston by hand to ensure that there is no binding.

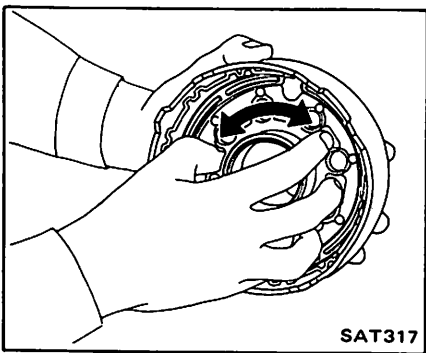

10. Reassemble springs and retainer. Reinstall snap ring. Be sure snap ring is properly seated.

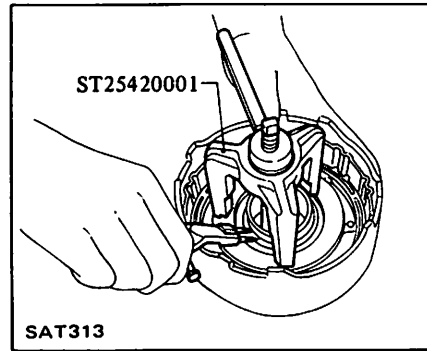

11. Now install driven plates (steel plate) and drive plates (friction plate) in the order shown below. Now install retainer plate and snap ring.

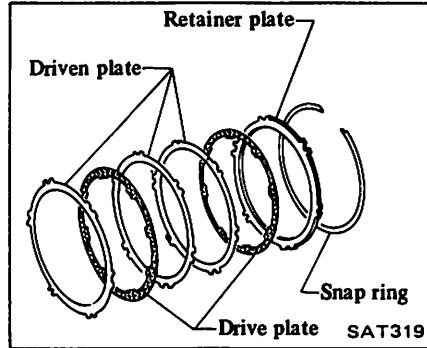

12. Measure clearance between retainer plate and snap ring.

Always measure the existing minimum clearance, since snap ring is a wave type.

Specified clearance:

Standard

1.0 - 1.4 mm (0.039 - 0.055 in)

Allowable limit

2.2 mm (0.087 in)

If necessary, try other retaining plates having different thicknesses until correct clearance is obtained.

Available retainer plate

Thickness mm (in)	Part number
3.6 (0.142)	31537-01X00
3.8 (0.150)	31537-01X01
4.0 (0.157)	31537-01X02
4.2 (0.165)	31537-01X03
4.4 (0.173)	31537-01X04

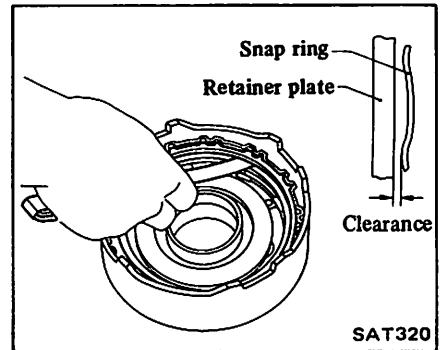

13. Testing high-reverse clutch (Front)

With high-reverse clutch (Front) assembled on oil pump housing, direct a jet of air into hole in clutch drum for definite clutch operation.

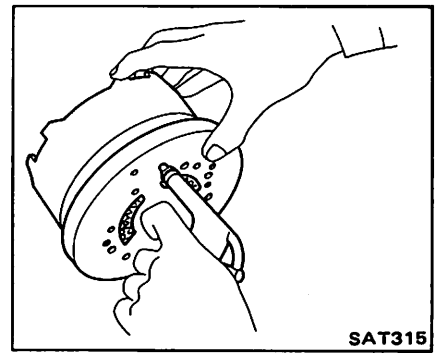

FORWARD CLUTCH (Rear)

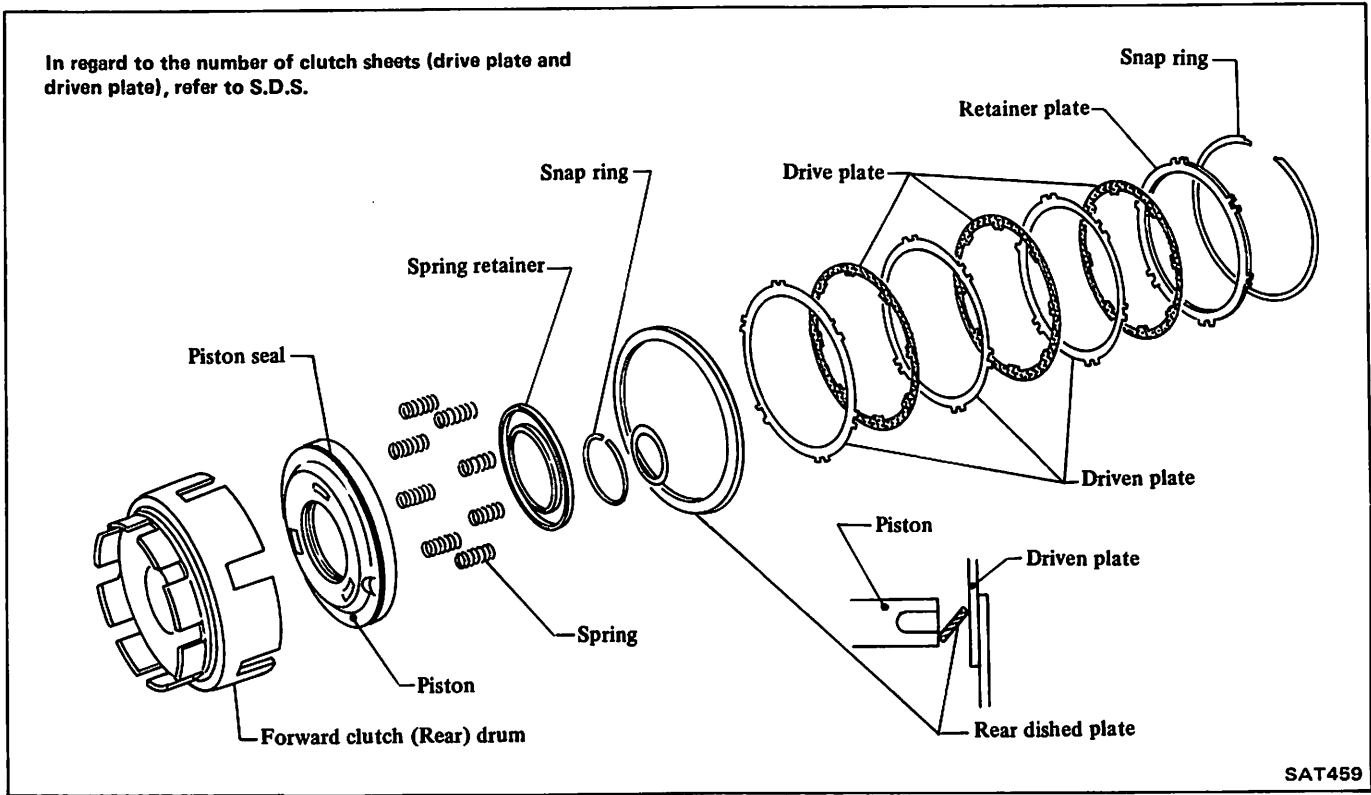

Service procedures for forward clutch (Rear) are essentially the same as those for high-reverse clutch (Front), with the following exception:

Specified clearance between retainer plate and snap ring:

Standard

0.8 - 1.2 mm
(0.031 - 0.047 in)

Allowable limit

2.8 mm (0.110 in)

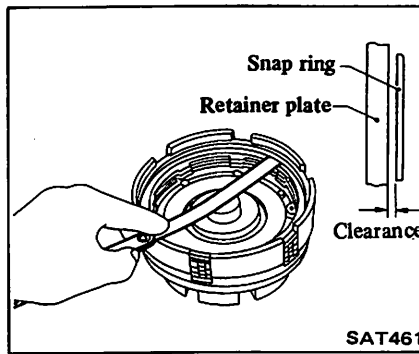

Test forward clutch (Rear)

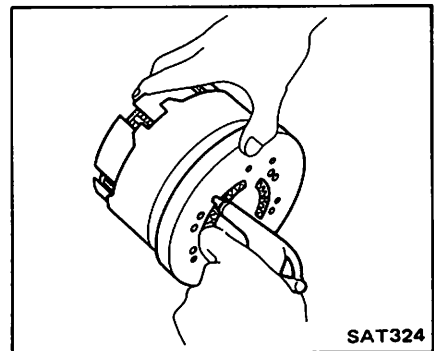

LOW & REVERSE BRAKE

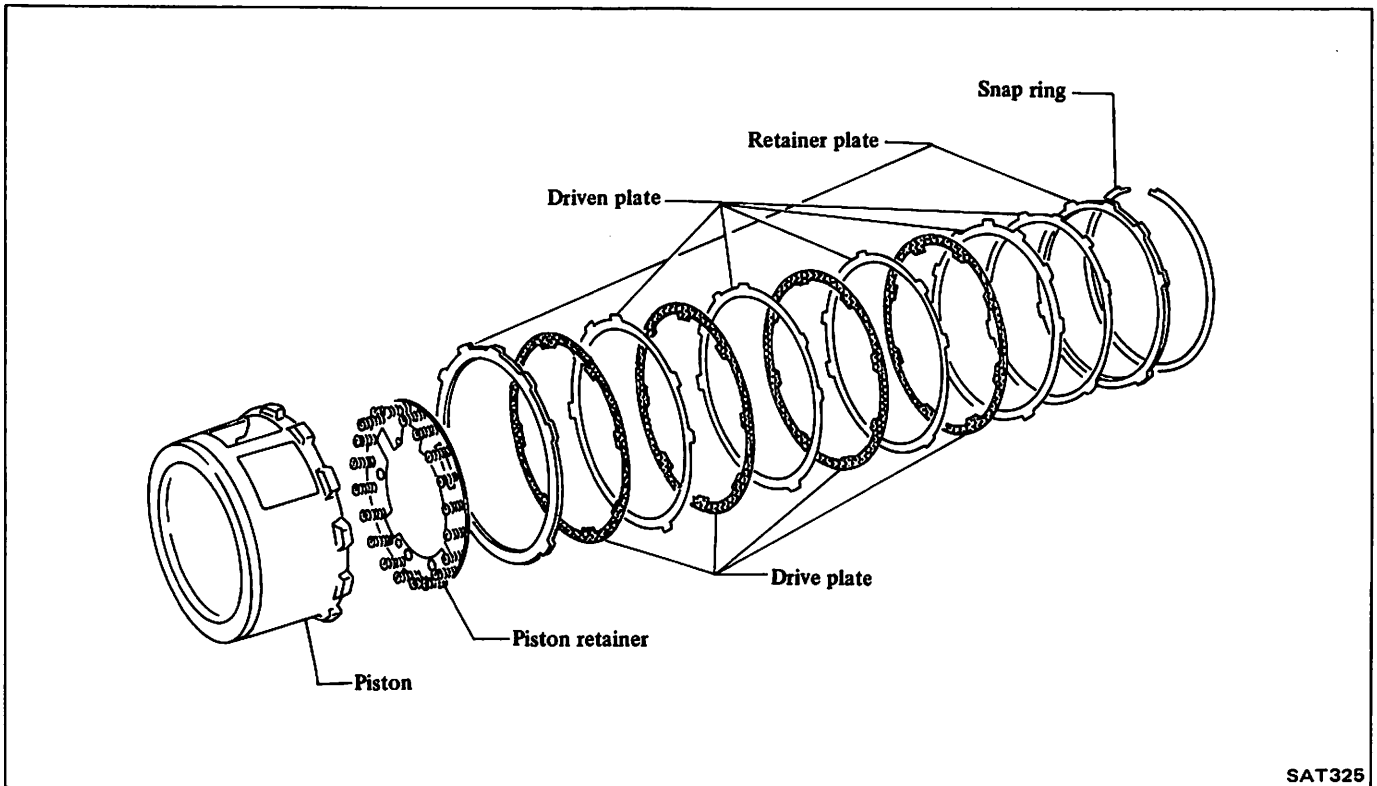

SAT325

- Examine low and reverse brake for damaged clutch drive plate facing and worn snap ring.
- Check drive plate facing for wear or damage; if necessary, replace.

Drive plate thickness:
Standard
 1.90 - 2.05 mm
 (0.0748 - 0.0807 in)
Allowable limit
 1.8 mm (0.071 in)

- Test piston return spring for weakness. Discard if it is too weak.

BRAKE BAND AND BAND SERVO

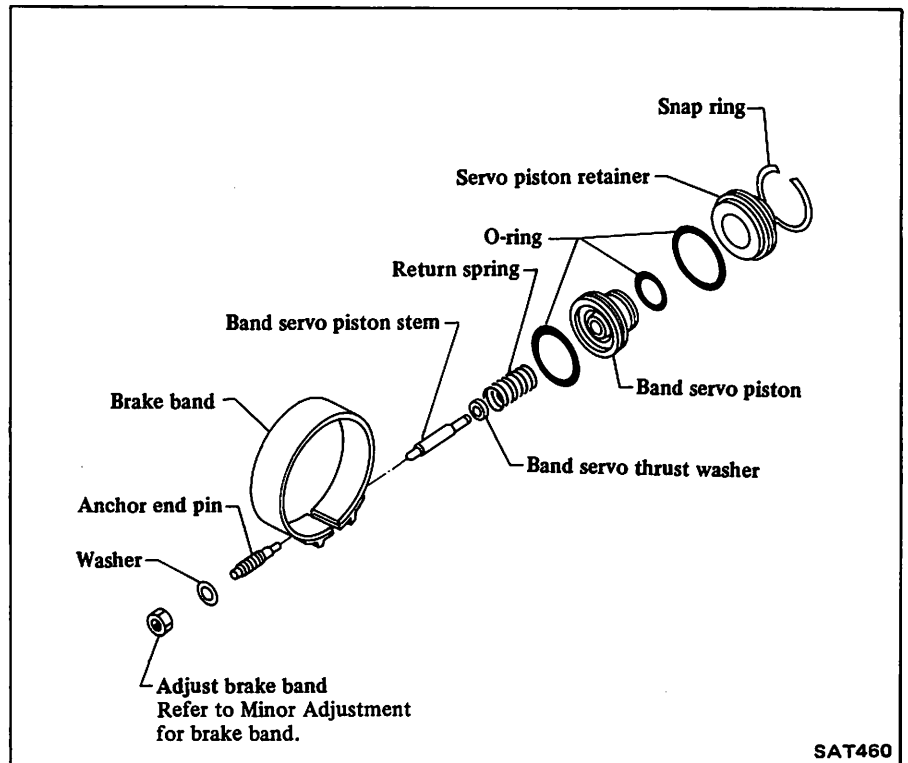

SAT460

- Inspect band friction material for wear. If cracked, chipped or burnt spots are apparent, replace the band.

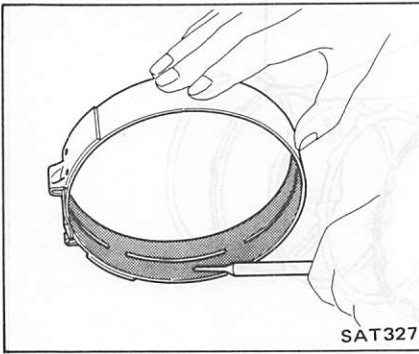

- Check band servo components for wear and scoring. Replace piston O-rings and all other components as necessary.

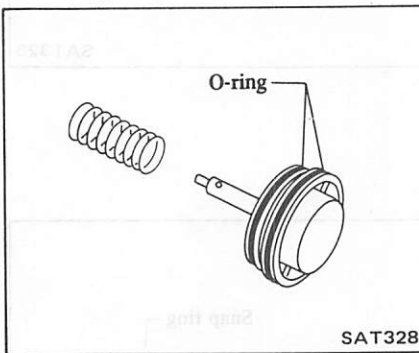

GOVERNOR

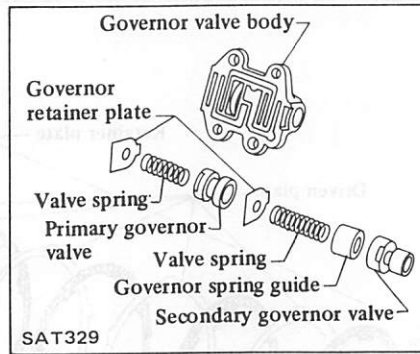

- Remove governor body from governor shaft.

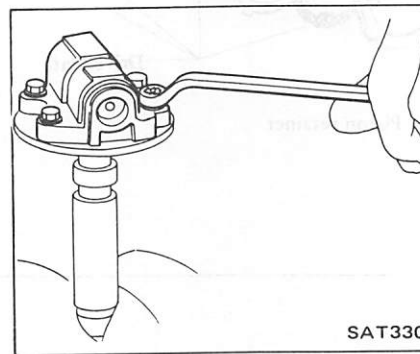

- Remove governor worm.

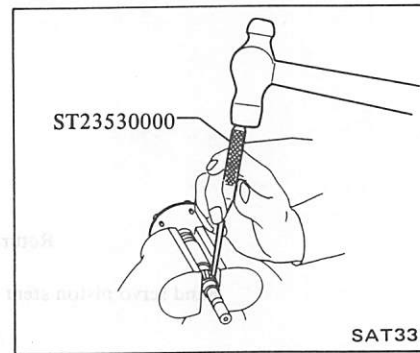

- Disassemble governor and check valves for indication of burning or scratches. Inspect springs for weakness or burning. Replace parts as necessary and reassemble.

Do not interchange components of primary and secondary governor valves.

Governor valve spring chart

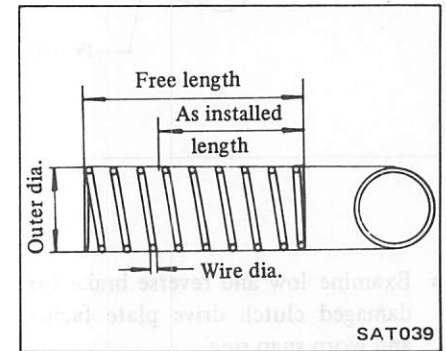

- Assemble governor on governor shaft.

Ⓣ : Governor valve body to governor shaft

5 - 7 N·m
 (0.5 - 0.7 kg-m,
 3.6 - 5.1 ft-lb)

Valve spring	Wire dia. mm (in)	Outer coil dia. mm (in)	No. of active coils	Free length mm (in)	Installed	
					Length mm (in)	Load N (kg, lb)
Primary governor	0.45 (0.0177)	10.45 (0.4114)	7	31.7 (1.248)	9.3 (0.366)	1.47 (0.15, 0.33)
Secondary governor	0.8 (0.031)	10.8 (0.425)	7	38.2 (1.504)	26.0 (1.024)	7.75 (0.79, 1.74)

PLANETARY CARRIER

The planetary carrier cannot be divided into its individual components. If any part of the component is faulty, replace the carrier as a unit.

- Check clearance between pinion washer and planetary carrier with a feeler.

Standard clearance:
0.20 - 0.70 mm
(0.0079 - 0.0276 in)

Replace if the clearance exceeds 0.80 mm (0.0315 in).

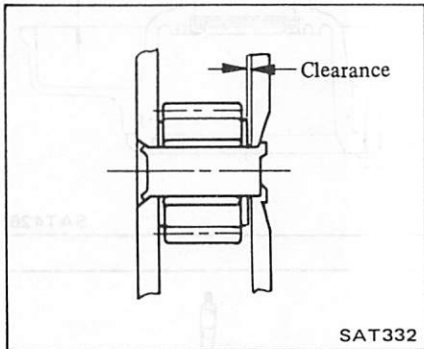

- Check planetary gear sets for damaged or worn gears. Gear sets that have been damaged by overheating will have a blue discoloration.

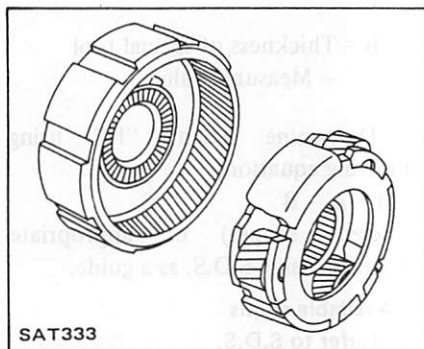

OUTPUT SHAFT AND IDLER SHAFT

1. Remove inner races from output shaft.

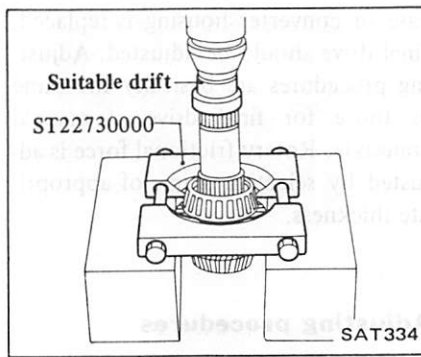

2. Remove outer races from idler gear.

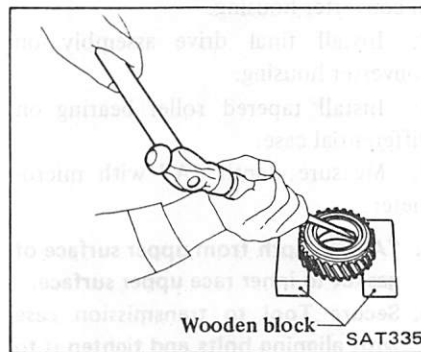

3. Check all gears for excessive wear, chips or cracks; replace as required.
4. Check shaft for bending, crack, wear, and worn spline; if necessary, replace.
5. Thoroughly clean oil and dirt from bearing with cleaning solvent, and dry with compressed air free from moisture. Check bearing to see that it rolls freely and is free from noise, crack, pitting, or wear.
6. Install outer races on idler gear.

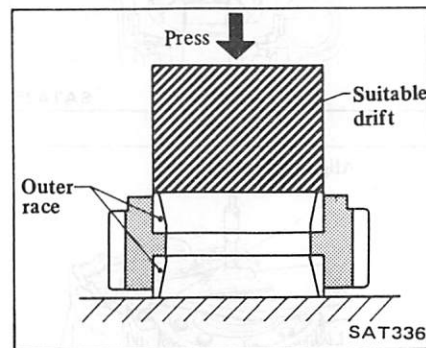

7. Install inner races on output shaft.

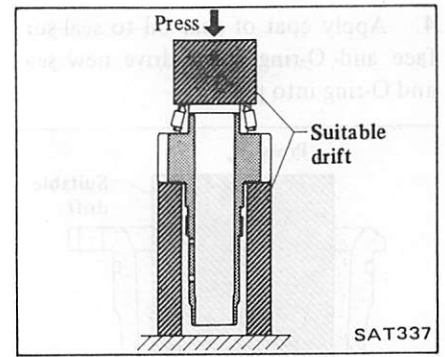

BEARING HOUSING

1. Remove bearing housing from transmission case.

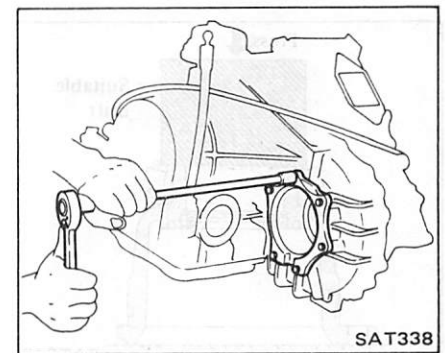

2. Remove inner race.

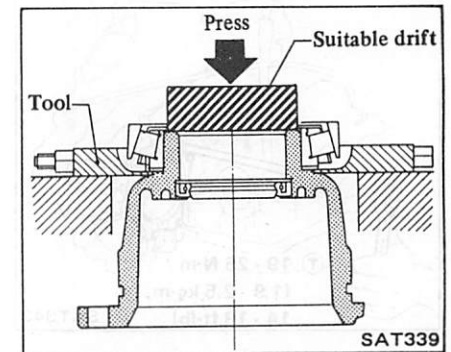

3. Remove oil seal and O-ring.

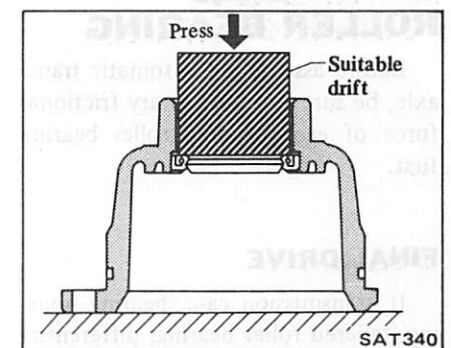

4. Apply coat of gear oil to seal surface and O-ring, then drive new seal and O-ring into place.

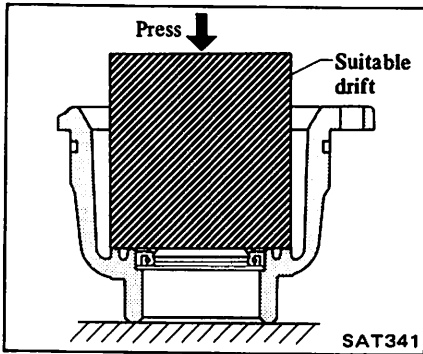

5. Install inner race.

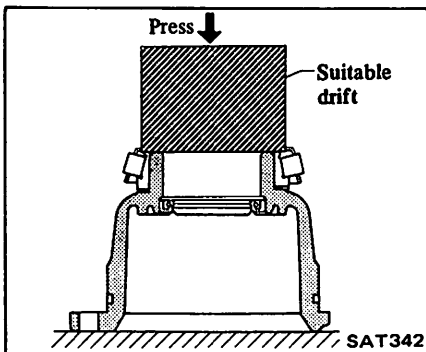

6. Install bearing housing.

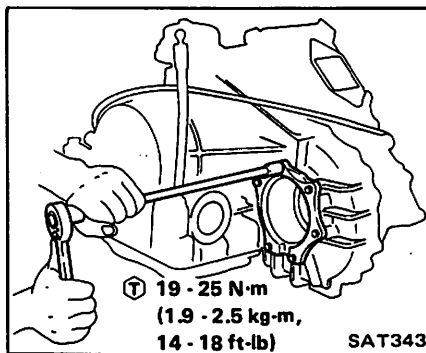

ADJUSTING ROTARY FRICTIONAL FORCE OF TAPERED ROLLER BEARING

Before assembling automatic transaxle, be sure to adjust rotary frictional force of each tapered roller bearing first.

FINAL DRIVE

If transmission case, bearing housing, tapered roller bearing, differential

case or converter housing is replaced, final drive should be adjusted. Adjusting procedures are basically the same as those for final drive of manual transaxle. Rotary frictional force is adjusted by selecting shims of appropriate thickness.

Adjusting procedures

Two types of adjusting procedures have been established.

Type A

1. Press bearing outer race into bore in converter housing.
2. Install final drive assembly on converter housing.
3. Install tapered roller bearing on differential case.
4. Measure depth "A" with micrometer.

- a. "A" is depth from upper surface of gasket to inner race upper surface.
- b. Secure Tool to transmission case with aligning bolts and tighten it to the specified torque.
- c. When measuring depth "A", be sure to use counterweight that is included in the Tool.
- d. Before measuring depth "A", ensure that bearing is seated properly. To seat it, turn final gear.

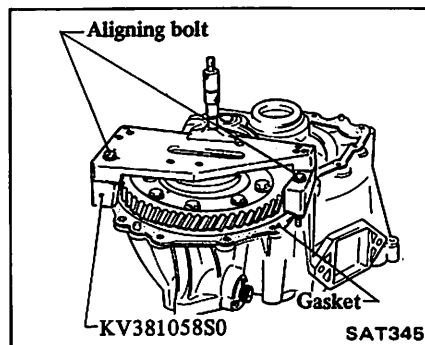
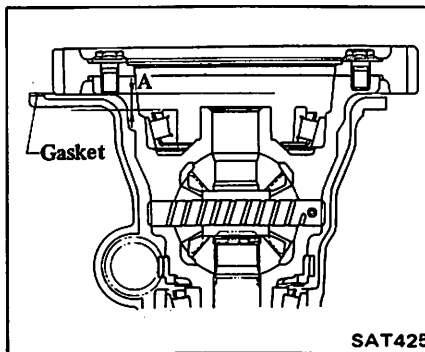

A = Measured value
– Thickness of special tool

5. Install bearing housing to transmission case.
6. Measure height "B" with micrometer.

Before measuring height "B", ensure that bearing is seated properly. To seat it, turn outer race while pushing it.

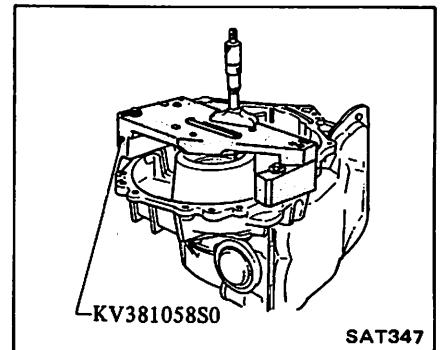
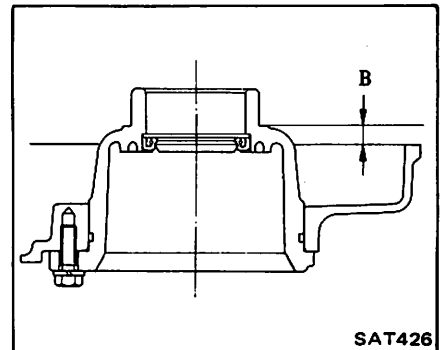

B = Thickness of special tool
– Measured value

7. Determine height "H" using following equation:

$$H = A - B$$

Select shim(s) of appropriate thickness, using S.D.S. as a guide.

Available shims
Refer to S.D.S.

8. Remove bearing retainer from transmission case.
9. Install shim selected in step 7 on bearing housing, and seat bearing inner race.
10. Apply vaseline to O-ring and install it on bearing housing.
11. Install bearing housing to transmission case.

12. Attach converter housing and gasket to transmission case.

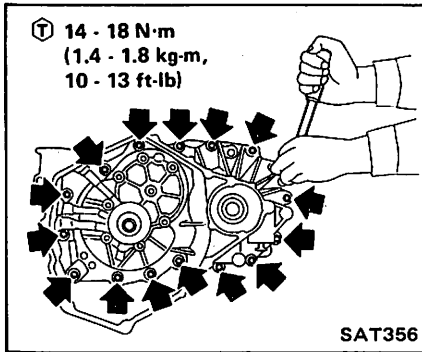

2. Press fit bearing inner race into place without shim.

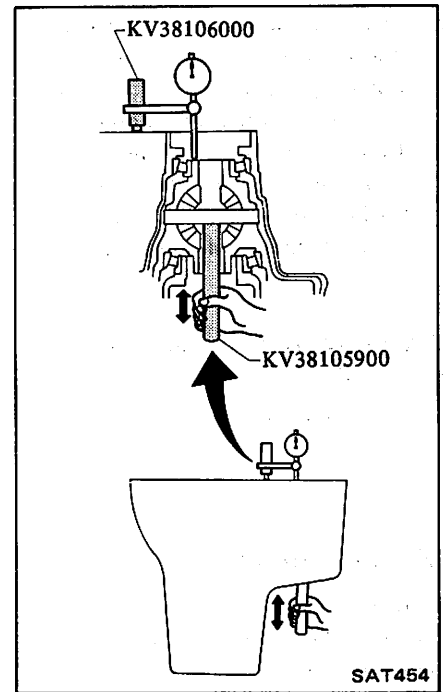
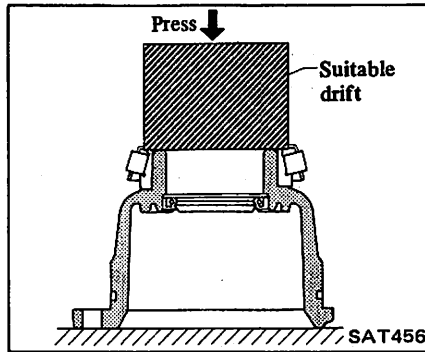

13. Measure rotary frictional force of final drive tapered roller bearing with KV38105900.

Specified rotary frictional force:

5.9 - 7.4 N·m
(60 - 75 kg·cm,
52 - 65 in·lb)

- a. Turn final drive assembly at least 10 times before measuring rotary frictional force.
- b. Changes in rotary frictional force of final drive assembly per revolution should be within 1.0 N·m (10 kg·cm, 8.7 in·lb) without binding.
- c. If any abnormalities are noted in b. above, or rotary frictional force is outside specified range, disassemble and reassemble again.

14. Disassemble transmission case and remove final drive assembly.

3. Install final drive assembly on transmission case.

4. Place gasket on transmission case, then install converter housing by tightening it to the specified torque.

Tighten bolts to the same torque in a crisscross fashion.

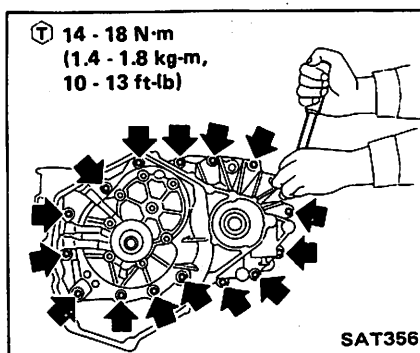

7. Select shim with appropriate thickness, using S.D.S. as a guide.

Available shims:
Refer to S.D.S.

8. Disassemble transaxle and insert shim, then reassemble again.

9. Measure rotary frictional force of diff. side tapered roller bearing with Tool KV38105900.

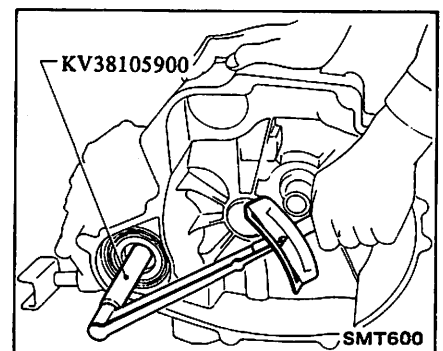

Type B

1. Remove bearing inner race on shim side only and take out shim.

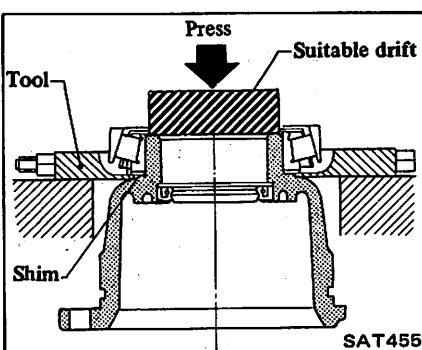

5. Attach dial gauge using Tool KV38106000.

If clamp diameter of dial gauge is too small or too large, attach dial gauge to Tool KV38106000 using a magnetic stand.

6. Insert Tool KV38105900 all the way into diff. side gear. Move Tool up and down and measure dial gauge deflection.

Specified rotary frictional force:

5.9 - 7.4 N·m
(60 - 75 kg·cm,
52 - 65 in·lb)

- a. Turn final drive assembly at least 10 times before measuring rotary frictional force.

- b. Changes in rotary frictional force of final drive assembly per revolution should be within 1.0 N·m (10 kg·cm, 8.7 in·lb) without binding.
- c. If any abnormalities are noted in b. above, or rotary frictional force is outside the specified range, disassemble and reassemble again.

Disassembly and assembly procedures

Refer to Section MT.

OUTPUT SHAFT

If transmission case, output shaft, tapered roller bearing or front cover is replaced, output shaft should be adjusted by means of shims.

1. Apply automatic transaxle fluid to bearing outer race.
2. Press bearing outer race into bore in transmission case.
3. Install two or three shims on front cover, and press bearing outer race into bore in front cover.

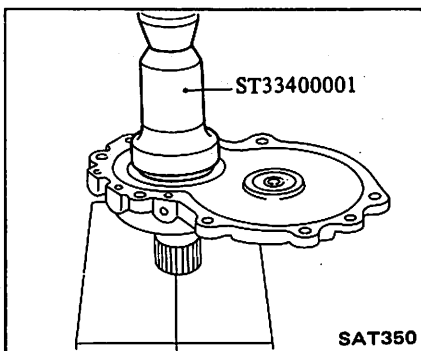

4. Install gasket and front cover on converter housing.

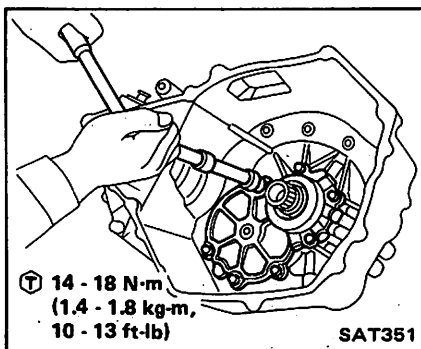

5. Measure rotary frictional force of output shaft.

Specified rotary frictional force:

0.35 - 0.47 N·m
(3.6 - 4.8 kg·cm,
3.1 - 4.2 in·lb)

- a. Turn output shaft at least 10 times before measuring rotary frictional force.
- b. Ensure that output shaft turns smoothly without binding.
- c. If any abnormalities are noted in b. above, or rotary frictional force is outside specified range, disassemble and reassemble again.

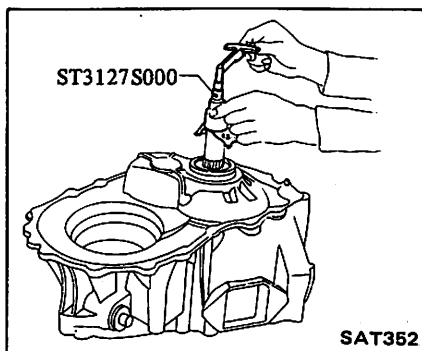

Available shims:
Refer to S.D.S.

6. Remove front cover and withdraw output shaft.

IDLER GEAR

1. Press bearing outer races onto idler gear.
2. Assemble bearing inner races and idler shaft to idler gear.
3. Attach idler gear assembly and output shaft assembly to converter housing.
4. Install gasket and front cover on converter housing as follows:
 - (1) Clean threads of bolts and converter housing with solvent.
 - (2) Apply locking sealer to threads of bolts and install them into place.

⊕ : 14 - 18 N·m
(1.4 - 1.8 kg·m,
10 - 13 ft·lb)

5. Install lock washer and idler gear bolt, and tighten bolt to specified torque.

Be sure to align lock washer with groove on converter housing.

⊕ : 26 - 36 N·m
(2.7 - 3.7 kg·m,
20 - 27 ft·lb)

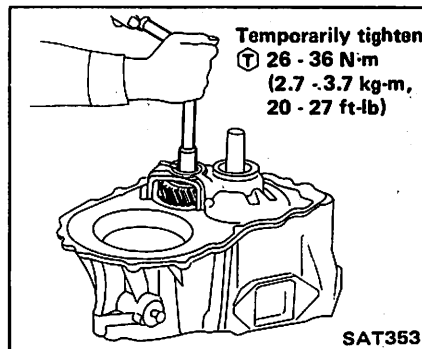

6. After tightening bolt, turn output shaft five complete rotations. Loosen idler gear bolt, then tighten it to specified torque.

⊕ : 3 - 4 N·m
(0.3 - 0.4 kg·m,
2.2 - 2.9 ft·lb)

7. Bend lock washer.

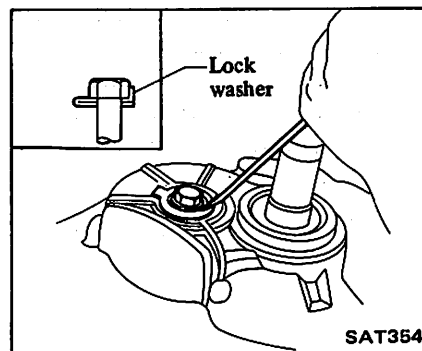

ADJUSTING END PLAY OF OUTPUT SHAFT

1. After adjusting rotary frictional force of tapered roller bearing used with output shaft, put solder on rear internal gear.

- a. Be sure to use fuse of 2.5 mm (0.098 in) in diameter or soldering plate of 2.5 mm (0.098 in) in thickness and 5 mm (0.20 in) in length, as maximum gear clearance is 2.3 mm (0.091 in). [If diameter or thickness is smaller than 2.5 mm (0.098 in), also use shim(s).]

b. Always install two fuses or soldering plates symmetrically over the periphery of internal gear.

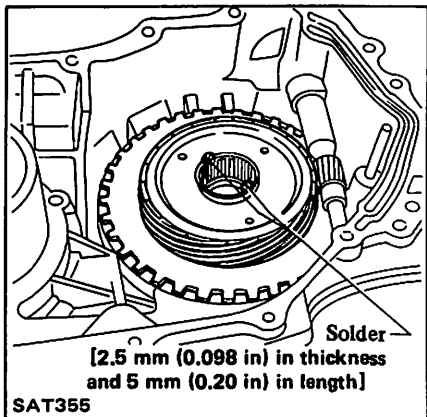

2. Install converter housing and output shaft assembly as a unit on transmission case.

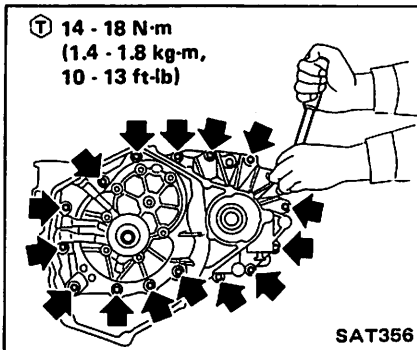

3. Disassemble output shaft assembly and remove soldering plate.

4. Measure thickness of soldering plate and, if necessary, select shim(s) of appropriate thickness so that end play of output shaft is within specified range.

End play:

0.25 - 0.55 mm
(0.0098 - 0.0217 in)

Available shims:

Refer to S.D.S.

FINAL ASSEMBLY

When installing/assembling needle bearing, bearing race, snap ring and seal ring, use the following illustration as a guide to installation procedures and locations.

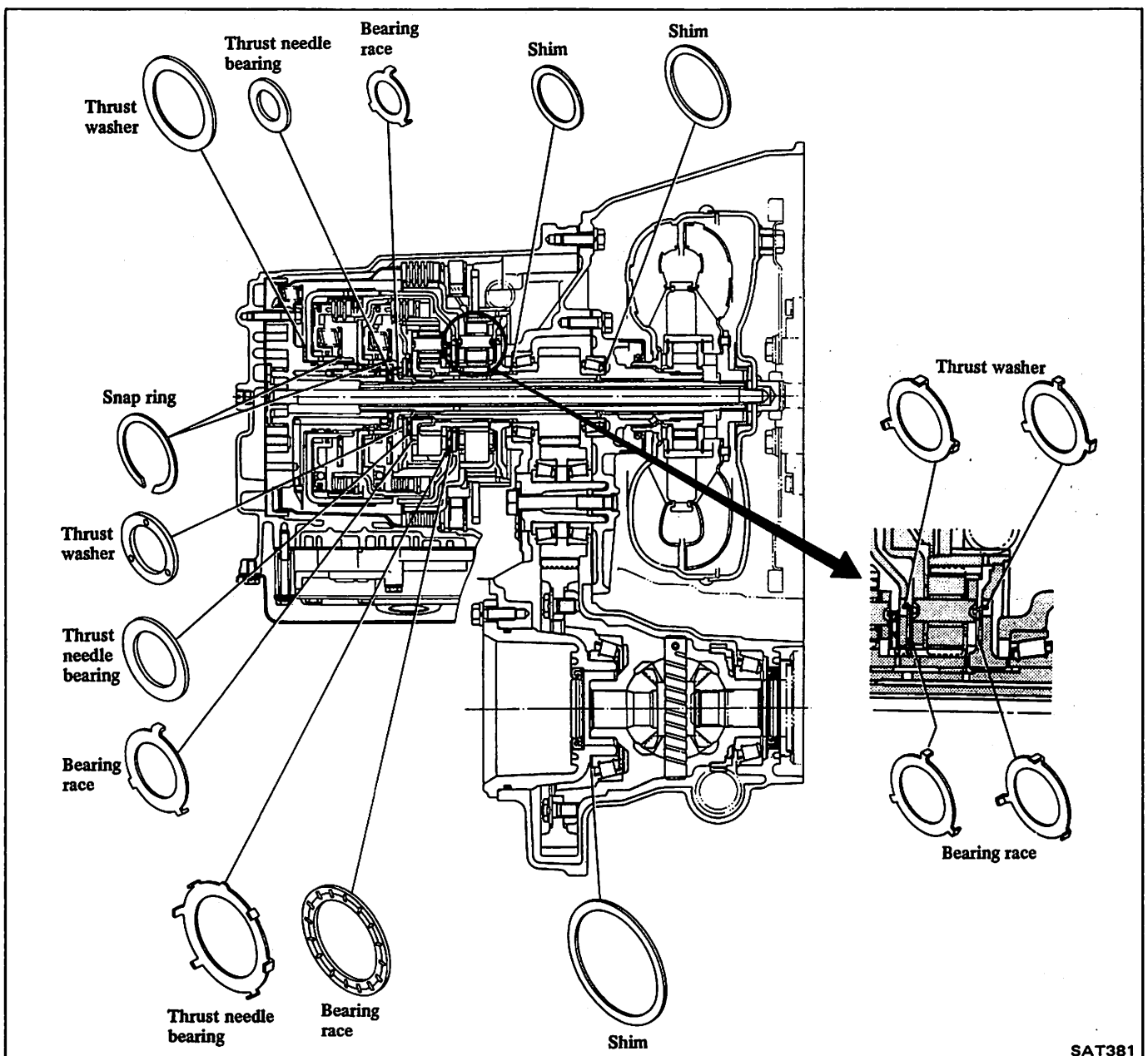

Major Overhaul Operations – AUTOMATIC TRANSAXLE

1. Before proceeding with the final assembly of all components, it is important to verify that the case, housing and parts are clean and free from dust, dirt and foreign matter (use air gun). Have a tray available with clean transaxle fluid for lubricating parts.

Petroleum jelly can be used to secure washers during installation. All new seals and rings should have been installed before beginning final assembly.

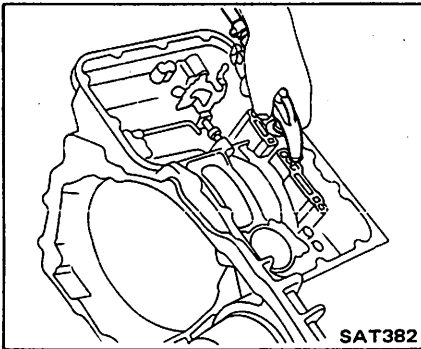

2. Apply automatic transaxle fluid or vaseline to outer diameter part of oil pump assembly. Install oil pump assembly, nylon washer and thrust bearing.

Align five bolt holes on oil pump assembly and transmission case and install oil pump.

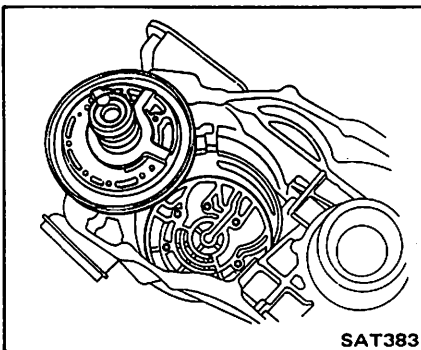

3. Apply automatic transaxle fluid or vaseline to low and reverse brake piston seal then install piston by tapping it evenly.

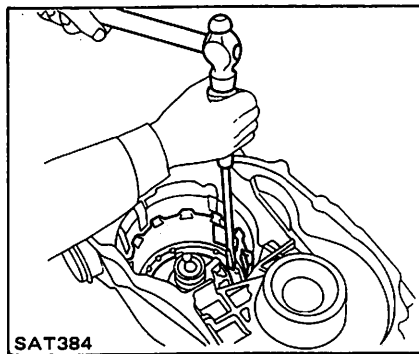

4. Install low and reverse brake piston retainer.

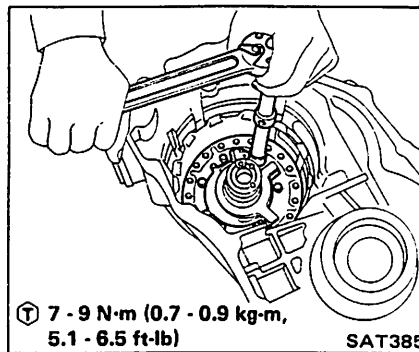

After installing piston retainer, make sure that its piston seal is not turned over by the application of air pressure to low and reverse brake circuit. The piston is installed properly if it move smoothly.

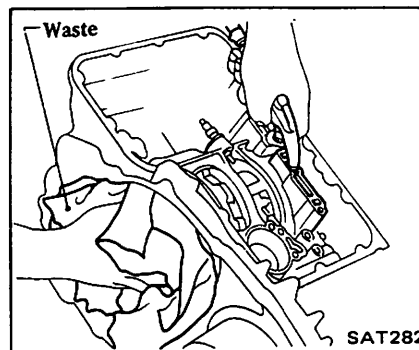

5. Install brake band. Apply automatic transaxle fluid or vaseline to band servo piston O-ring and install band servo piston, return spring and snap ring holding piston with a small vice.

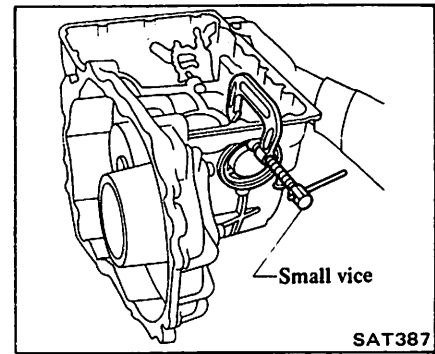

6. Apply automatic transaxle fluid or vaseline to seals in oil pump housing, then install high-reverse clutch (Front).

7. Install forward clutch (Rear), front internal gear, thrust bearing, bearing race, front carrier, bearing race, thrust bearing and sun gear assembly in the reverse order of removal. Prior to assembly, apply automatic transaxle fluid or grease to thrust bearings and bearing races.

8. Install low and reverse brake retainer plate, drive and driven plates, retainer plate and snap ring.

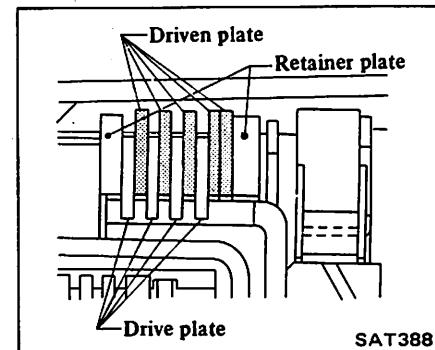

9. After low and reverse brake has been completely assembled, measure clearance between snap ring and retainer plate. If measurement exceeds specifications it can be adjusted by replacing retainer plate with one of a different thickness.

Low and reverse brake clearance:

Standard

1.90 - 2.20 mm
(0.0748 - 0.0866 in)

Allowable limit

3.8 mm (0.150 in)

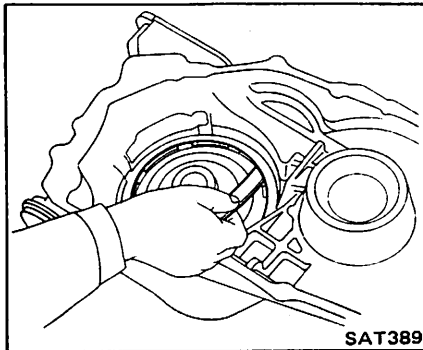

13. Apply vaseline to thrust washer and install it on rear carrier.
14. Install one-way clutch together with rear carrier by turning rear carrier clockwise.

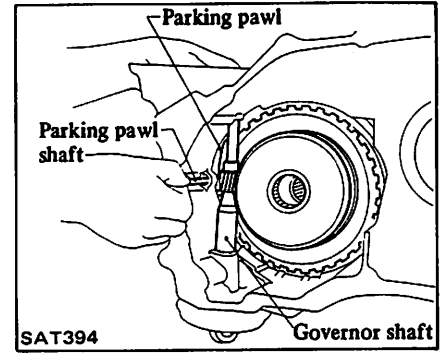
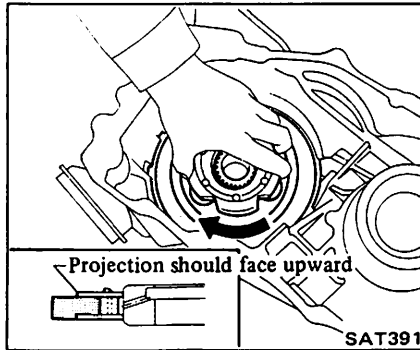

Available retainer plate (Piston side)

Thickness mm (in)	Part Number
3.6 (0.142)	31667-01X00
3.8 (0.150)	31667-01X01

Available retainer plate (O.W.C. side)

Thickness mm (in)	Part Number
3.6 (0.142)	31667-01X00
3.8 (0.150)	31667-01X01
4.0 (0.157)	31667-01X02
4.2 (0.165)	31667-01X03
4.4 (0.173)	31667-01X04

15. Install snap ring

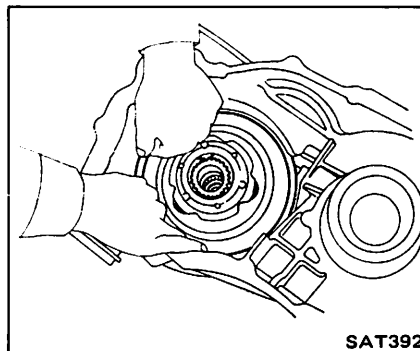

18. Install governor shaft retaining bolt.

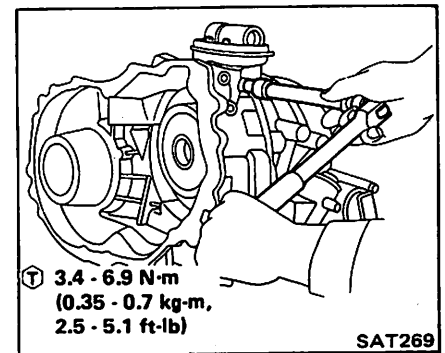

10. Install bearing race on connecting shell.
11. Apply vaseline to thrust washer, then attach it to rear carrier.
12. Install one-way clutch assembly to rear carrier by turning it counterclockwise.

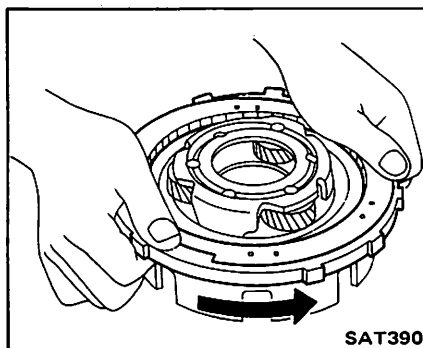

Install snap ring. Ensure that its bent end is positioned so that it does not interfere with parking pawl.

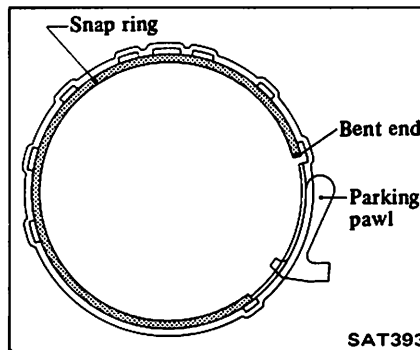

19. Install seal bushing.

CAUTION:
Always install seal bushing to prevent sun gear and output shaft from becoming jammed.

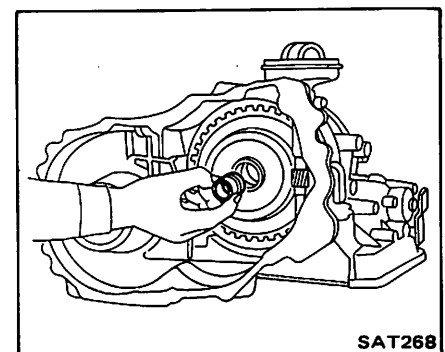

16. Apply vaseline to bearing race, then attach it to rear internal gear.
17. Install rear internal gear, then assemble governor shaft assembly, parking pawl, return spring and parking pawl shaft.

20. Adjust end play of output shaft. Refer to Adjusting End Play of Output Shaft.
21. Adjust rotary frictional force of output shaft and idler gear tapered roller bearing. Refer to Adjusting Rotary Frictional Force of Tapered Roller Bearing.

22. Adjust rotary frictional force of final drive tapered roller bearing. Refer to Adjusting Rotary Frictional Force of Tapered Roller Bearing.

23. Install final drive assembly on transmission case.

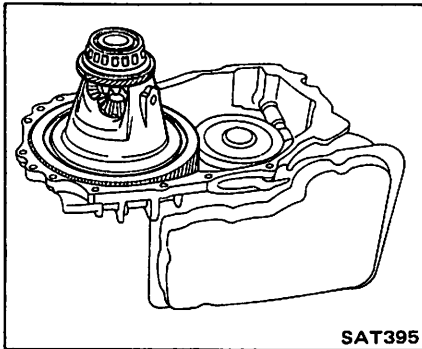

24. Apply vaseline to output shaft shim selected, then attach it to output shaft.

25. Put gasket on transmission case.

26. Install converter housing assembly on transmission case.

27. Turn parking gear (rear internal gear) clockwise with screwdriver while supporting converter housing assembly by hand, until output shaft splines, front carrier, and rear internal gear are engaged properly.

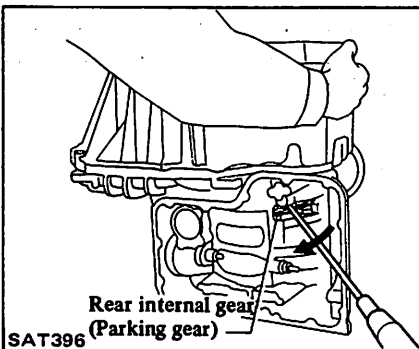

28. Tighten converter housing securing bolts to the specified torque.

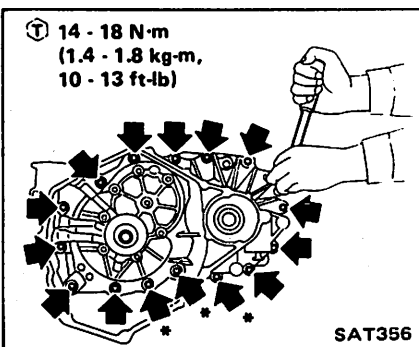

Before installing bolts marked “*” in figure below, ensure that bolt threads are clean and that locking sealer has been applied. Also ensure that the transmission case has been cleaned with solvent.

29. Apply vaseline to lathe cut ring, then install return spring and accumulator piston on transmission case.

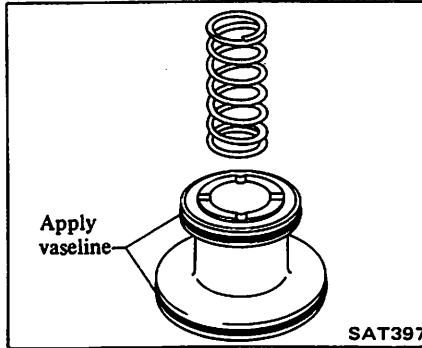

30. Adjust brake band. Refer to Brake Band Adjustment.

31. Assemble parking actuator support and throttle wire to transmission case.

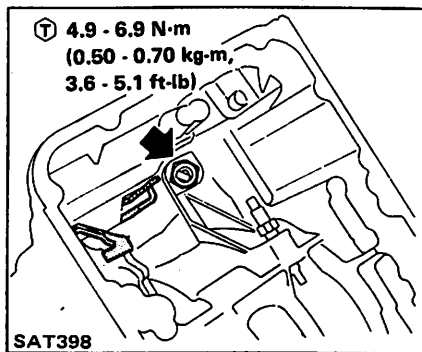

32. Apply grease and vaseline to manual shaft.

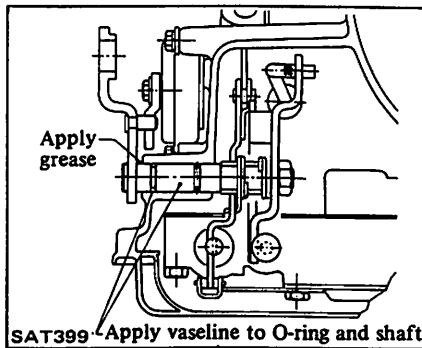

33. Install throttle lever, manual plate, manual shaft, selector range

lever and parking rod assembly, then secure them with retaining pin.

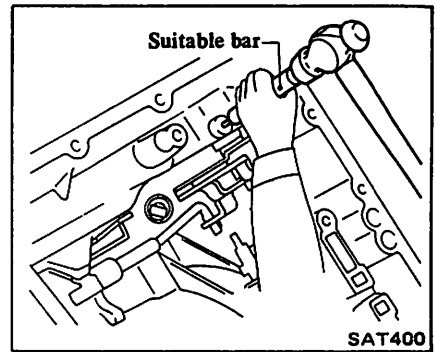

Install retaining pin as shown in figures below.

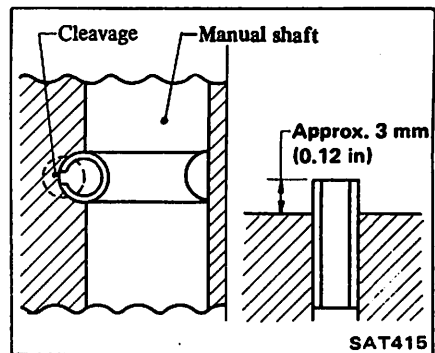

34. Tighten manual shaft securing nuts as follows:

(1) Tighten inside nut to the specified torque.

⌚: Inside nut
25 - 31 N·m
(2.6 - 3.2 kg·m,
19 - 23 ft·lb)

(2) Tighten outside nut to the specified torque.

⌚: Outside nut
25 - 31 N·m
(2.6 - 3.2 kg·m,
19 - 23 ft·lb)

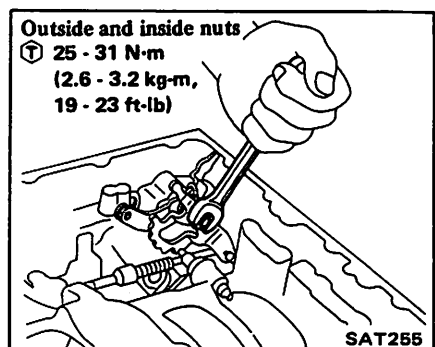

35. Insert manual valve to control valve body, then assemble them to transmission case. Then install magnet in place.

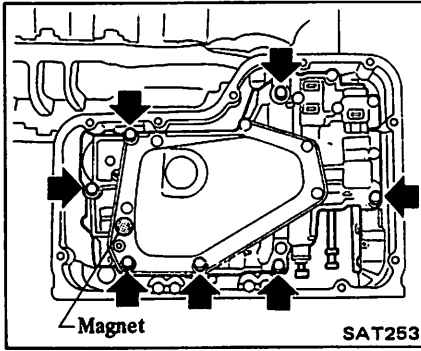

Install manual valve, manual plate, detent valve and throttle lever securely, as shown in figure below.

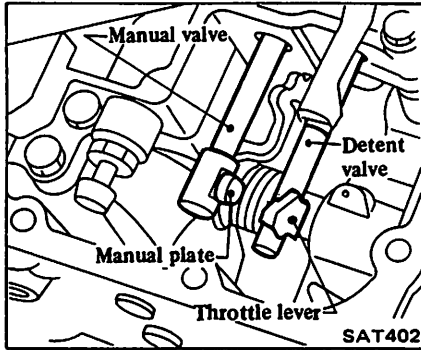

36. Before installing oil pan, check alignment and operation of manual lever and parking pawl engagement. Blow mechanism with air to clean. Make final check to be sure all bolts are installed in valve body.

37. Install oil pan with new gasket and oil pan guard.

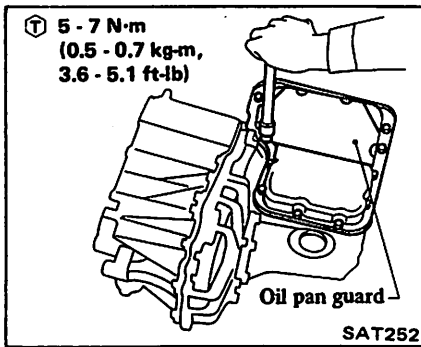

38. Install seal ring and governor cap, then secure it with snap retainer.

When installing snap retainer, pay attention to its direction.

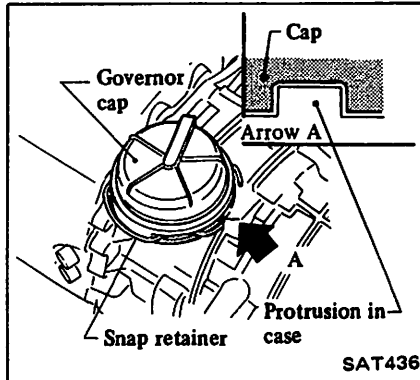

39. Install oil pump shaft and input shaft.

Ensure that concave portion of oil pump faces outward.

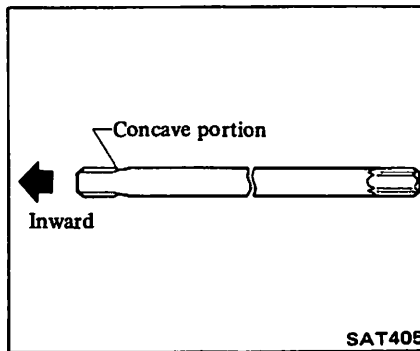

40. Carefully inspect torque converter for damage. Check converter hub for grooves caused by hardened seals. Also check bushing contact area.

41. Lubricate oil pump lip seal and converter neck before installing converter.

42. Install torque converter to converter housing.

Be careful not to scratch front cover oil seal.

43. Apply sealant to threads of hexagon plug and install it in place.

Ⓣ : Hexagon plug
7 - 13 N·m
(0.7 - 1.3 kg-m,
5.1 - 9.4 ft-lb)

44. Install inhibitor switch to transaxle case.

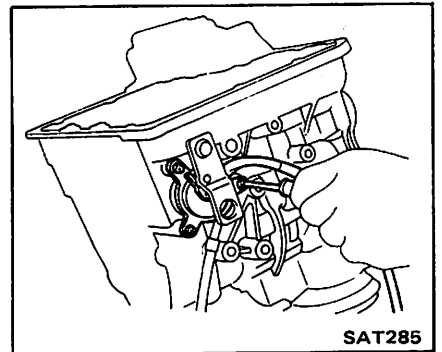

45. Adjust inhibitor switch. Refer to Minor Adjustments.

46. Make sure that manual lever operates smoothly.

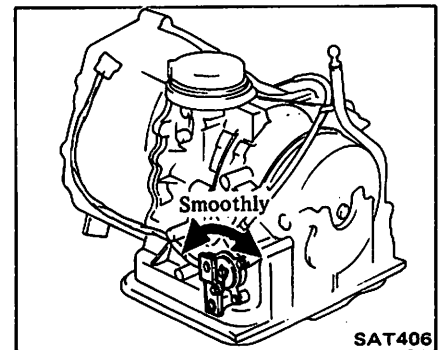

TRUBLE-SHOOTING AND DIAGNOSES

PRELIMINARY CHECKS (Prior to road testing)

Verify customer complaint

The customer should supply as much information as possible, including any unusual characteristics that accompany the complaint.

Fluid level

To properly check fluid level:

- 1) Place car on a level surface.
- 2) Put wheel chocks in place and apply parking brake securely.
- 3) Warm up engine on fast idle.
- 4) Return engine to curb idling speed.
- 5) Slowly move the control lever through the entire shift pattern, and return it to park.
- 6) Remove the dipstick, clean it, and replace it fully in the filler tube.
- 7) Quickly remove it again and read the level.

The "L" mark on the dipstick indicates the transaxle is approximately 0.4 liter (7/8 US pt, 3/4 Imp pt) low. Add only clean Dexron transaxle fluid (or equivalent).

Fluid leakage

To detect a fluid leak:

- 1) Raise vehicle.
- 2) Clean area suspected of leaking.
- 3) Start engine, apply foot brake, place control lever in drive, and wait a few minutes.
- 4) Stop engine.
- 5) Check for fresh leakage.

If the governor cap is suspected:

- 1) Open hood.
- 2) Remove snap retainer, governor cap and seal ring, then reinstall them. Refer to ON-VEHICLE SERVICE.
- 3) Clean the area around the governor cap.
- 4) Run the car at highway speeds.
- 5) Check the governor cap for fresh leakage.

To aid in locating leaks, use the following list of seals and gaskets.

- 1) Converter housing
 - Front cover oil seal (transaxle front seal).
 - Crankshaft oil seal.
- Bolts of converter housing to case and converter housing to front cover.

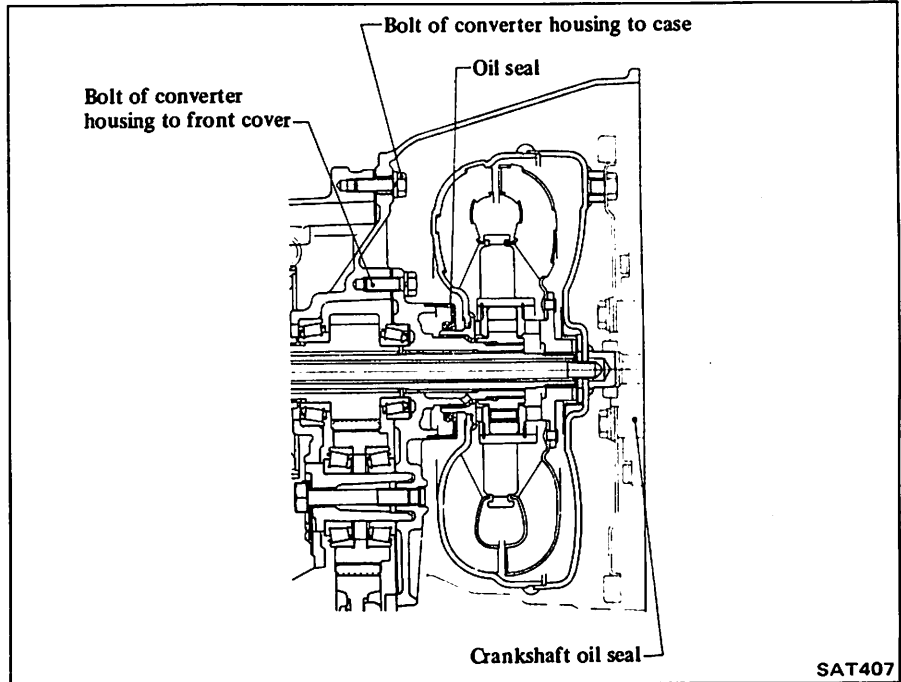

SAT407

- 2) Transaxle and bearing housing.
 - Junction of transmission case and converter housing.
 - Junction of transmission case and bearing housing.
 - Oil cooler inlet and outlet tube connectors.
- Oil pressure inspection ports.
- O-ring of manual shaft.
- O-ring of throttle wire.
- Speedometer pinion sleeve.
- Drive shaft oil seals.
- Governor cap seal ring.

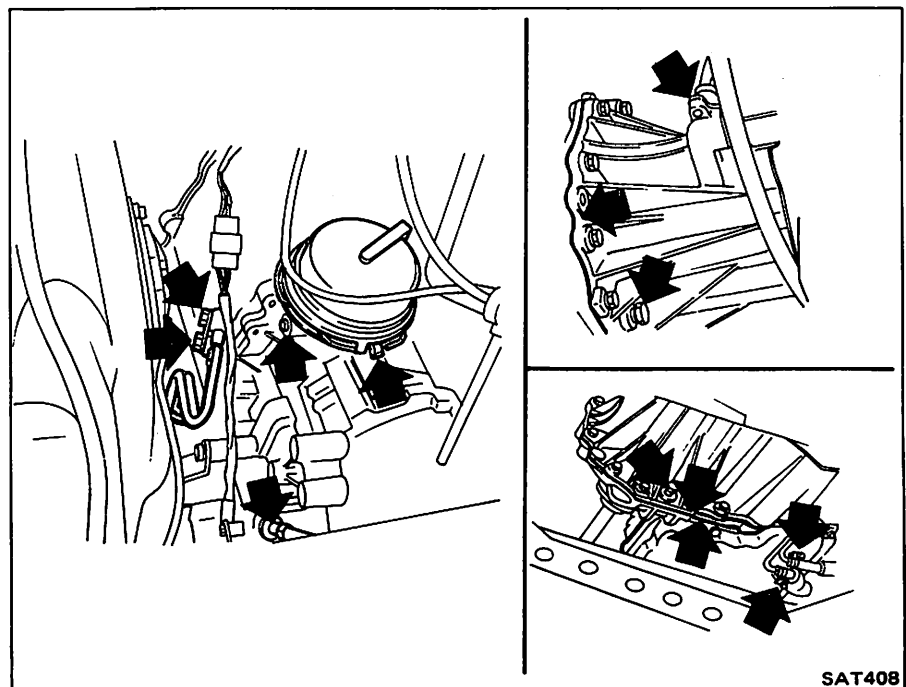

SAT408

Fluid condition

Transaxle fluid color and texture can aid greatly in transaxle trouble-shooting. When checking fluid level, examine the transaxle fluid and note its color, texture, and odor. Some common forms of contamination are listed below:

- 1) Dark of Black Fluid:
 - With a burned odor
 - Worn friction material.
 - Without an odor
 - Slight engine coolant leak (in radiator).
- 2) Milky Pink Fluid: Water Contamination
 - Coolant leak.
 - Road water entering through filler tube or breather.
- 3) Varnished Fluid, light to dark brown and tacky: Oxidation
 - Over or Underfilling.
 - Overheating.

Engine idle

Check and adjust idle to specifications.

- Idling speed:**
850 rpm at “N” range

Engine oil and coolant levels

Prior to road testing, check engine oil and coolant levels, and fill as necessary.

Control cable

Start in park position, depress detent button and slowly move the gear selector through all ranges. The detent “clicks” should correspond with the range indicator.

DIAGNOSTIC ROAD TEST

Prior to road testing, perform the preliminary inspections outlined earlier. If the car is not equipped with a tachometer, install a portable tachometer in the car. And also install a suitable pressure gauge. If the customer has a specific complaint, select road conditions similar to those described. (e.g. steep hills, freeways, etc.)

Follow the test sequence as outlined in this section and mark the results on the Symptom Chart on page AT-50. It may be necessary to repeat sections of the test under different throttle conditions. (e.g. light, medium of full throttle.) After completing the road test, compare the test results to the Trouble-shooting Chart on page AT-47.

ROAD TESTING

1. Park Range

Place the control lever in “P” range and start the engine. Stop the engine and repeat the procedure in all other ranges and neutral. In Park, the car should be locked in position, unable to roll or move. Make all results on the Symptom Chart.
2. Reverse

Manually shift the control lever from “P” to “R”, and note shift quality. Drive the car in reverse long enough to detect slippage or other abnormalities. Note results.
3. Neutral

Manually shift the control lever from “P” to “N” and note quality. In

neutral no clutches or bands are applied, and there should be no movement. Note results.

4. Drive Range

Manually shift the control lever to range “D”, and note shift quality. Drive the car through all automatic shifts and in all gear ranges. Note shift quality and timing [km/h (MPH)], check for slippage, noise, or other abnormal conditions. If necessary, drive the test sequence under different throttle openings (e.g. light, medium or full throttle).

5. Range “2”

Manually shift the control lever to range “2”. Check for slippage, hesitation or abnormal condition. When the lever is set at this position, the transaxle will be automatically shifted between 1st and 2nd gears in response to the depression of the accelerator pedal. However, the transaxle is not shifted to 3rd gear. When the car is slowing down, the transaxle will automatically down-shift.

6. Range “1”

Manually shift the control lever to range “1”. Note shift quality. It should, however, downshift immediately to 2nd gear and downshift again to 1st gear as road speed decreases. Accelerate and decelerate in 1st gear to determine engine braking. Note results.

The transaxle should not shift into 1st gear from “D” range if the car road speed is above approximately 65 km/h (40 MPH).

7. Record line pressure and governor pressure at each range and at each throttle valve opening in accordance with the pressure testing described below.

CAR SPEED AND LINE PRESSURE WHEN SHIFTING GEARS

This check could be carried out when oil temperature is between 43 to 57°C (109 to 135°F). Throttle position is determined by wire length.

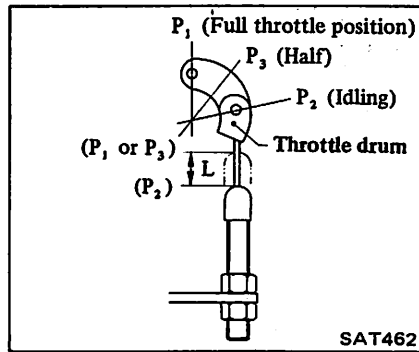

Throttle position	Throttle Wire length L mm (in)	Gear shift	Car speed km/h (MPH)	Drive shaft revolutions rpm	Line pressure kPa (kg/cm ² , psi)
Full throttle	25.6 (1.008)	D ₁ → D ₂ (2 ₁ → 2 ₂)	52 - 60 (32 - 37)	480 - 555	549 - 696 (5.6 - 7.1, 80 - 101)
		D ₂ → D ₃	102 - 110 (63 - 68)	945 - 1,020	
		D ₃ → D ₂	99 - 106 (62 - 66)	920 - 980	
		D ₂ → D ₁ (2 ₂ → 2 ₁)	41 - 49 (25 - 30)	380 - 455	
		D ₃ → 2 ₂ (D ₃ → 1 ₂)	—	—	
		1 ₂ → 1 ₁	—	—	
Half throttle (4/8 open)	14.6 (0.575)	D ₁ → D ₂ (2 ₁ → 2 ₂)	23 - 33 (14 - 21)	215 - 305	549 - 696 (5.6 - 7.1, 80 - 101)
		D ₂ → D ₃	54 - 64 (34 - 40)	500 - 590	
		D ₃ → D ₂	40 - 48 (25 - 30)	370 - 445	
		D ₂ → D ₁ (2 ₂ → 2 ₁)	11 - 21 (7 - 13)	105 - 195	
		D ₃ → 2 ₂ (D ₃ → 1 ₂)	—	—	
		1 ₂ → 1 ₁	60 - 68 (37 - 42)	560 - 635	
Light throttle (1/8 open)	3.8 (0.150)	D ₁ → D ₂ (2 ₁ → 2 ₂)	13 - 19 (8 - 12)	120 - 180	245 - 343 (2.5 - 3.5, 36 - 50)
		D ₂ → D ₃	23 - 29 (14 - 18)	210 - 270	245 - 343 (2.5 - 3.5, 36 - 50)
		D ₃ → D ₂	19 - 26 (12 - 16)	180 - 240	245 - 343 (2.5 - 3.5, 36 - 50)
		D ₂ → D ₁ (2 ₂ → 2 ₁)	—	—	245 - 343 (2.5 - 3.5, 36 - 50)
		D ₃ → 2 ₂ (D ₃ → 1 ₂)	—	—	549 - 696 (5.6 - 7.1, 80 - 101)
		1 ₂ → 1 ₁	—	—	245 - 343 (2.5 - 3.5, 36 - 50)

SHIFT SCHEDULE

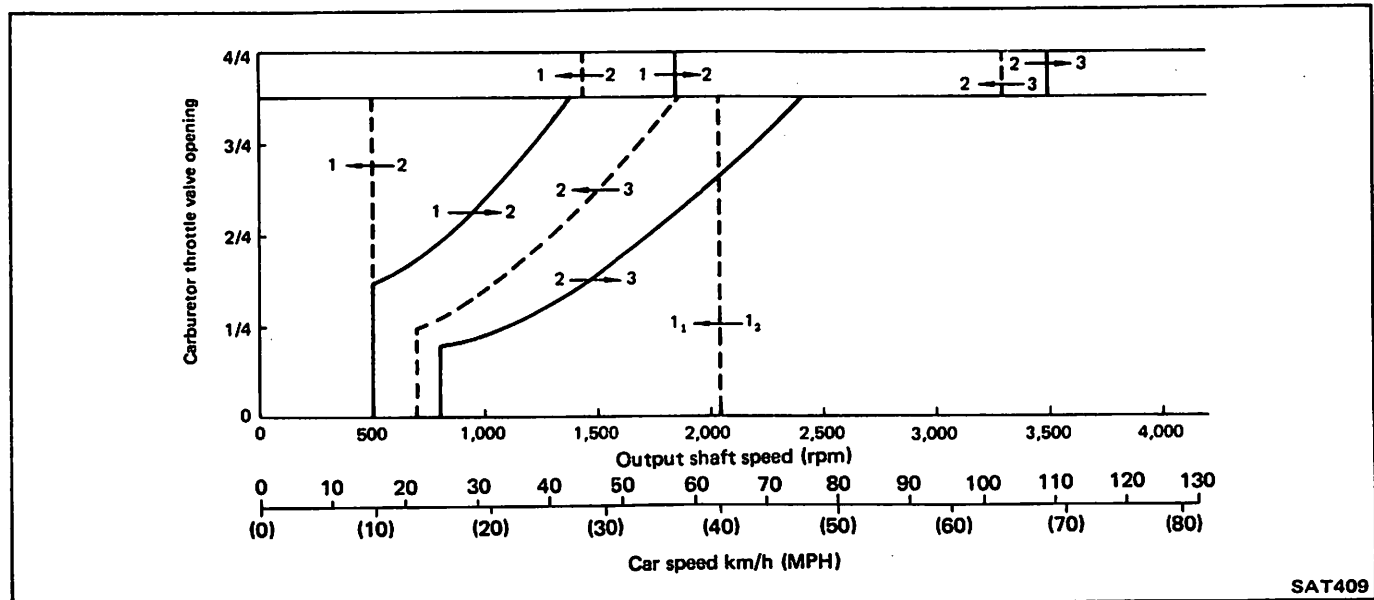

SAT409

PRESSURE TESTING

The RN3F01A transaxle is provided with three pressure test ports. All are useful for transaxle trouble-shooting, Line Pressure [To high-reverse clutch (Front)], Line Pressure [To forward clutch (Rear)] and Governor Pressure.

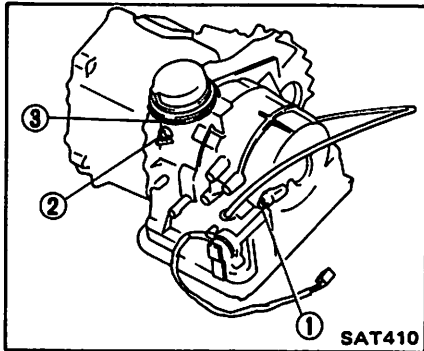

- 1 Line pressure [To high-reverse clutch (Front)]
- 2 Line pressure [To forward clutch (Rear)]
- 3 Governor pressure

At idling

Range	Line pressure kPa (kg/cm ² , psi)
R	628 - 775 (6.4 - 7.9, 91 - 112)
D	245 - 343 (2.5 - 3.5, 36 - 50)
2	245 - 343 (2.5 - 3.5, 36 - 50)
1	245 - 343 (2.5 - 3.5, 36 - 50)

At stall test

Range	Line pressure kPa (kg/cm ² , psi)
R	1,275 - 1,471 (13.0 - 15.0, 185 - 213)
D	549 - 696 (5.6 - 7.1, 80 - 101)
2	549 - 696 (5.6 - 7.1, 80 - 101)
1	549 - 696 (5.6 - 7.1, 80 - 101)

- a. Line pressure can be measured by gradually opening throttle, starting with engine idle.
- b. Line pressure should be measured while fluid temperature is within the 43 to 57°C (109 to 135°F) range.

LINE PRESSURE

1. Install pressure gauge to line pressure port. (When shift lever is in "D", "2" or "1" range, install pressure gauge to port ② and when in "R" range, install pressure gauge to port ① shown above.) Locate the gauge so it can be seen by driver. Measure line pressure at idling and at stall test.
2. Road test car and note pressure under different throttle conditions.

Key points of pressure testing are:

- a) Pressure at idle: Look for a steady rise in pressure as car speed increases under light load.
- b) Pressure drop between shift points should not exceed 98 kPa (1.0 kg/cm², 14 psi). Excessive pressure drop may indicate an internal leak at a servo or clutch seal.

GOVERNOR PRESSURE

1. Install pressure gauge to governor pressure port. Locate the gauge so it can be seen by driver.
2. Road test car and note pressure at different road speeds. Governor pressure increases directly with road speed, and should always be less than line pressure.

STALL TESTING

The stall test is an effective method of testing clutch and band holding ability, torque converter one-way clutch operation, and engine performance. A stall test should only be performed as a last resort because of the high fluid temperature it generates and the excessive load it places on the engine and transaxle.

CAUTION:

- a. Transaxle and engine fluid levels should always be checked and fluid added as needed.
- b. Run engine at 1,200 rpm to attain proper warm-up.
- c. During test, never hold throttle wide-open for more than 5 seconds.
- d. Do not test more than two gear ranges without driving car to cool off engine and transaxle.

STALL TEST PROCEDURE

1. Install a tachometer where it can be seen by driver during test.
2. Set hand brake and block wheels.
3. Start engine and place shift lever in "D" range.
4. Apply foot brake and accelerate to wide-open throttle. Do not hold throttle open longer than five seconds.
5. Quickly note the engine stall speed and immediately release throttle.

Stall revolution:
2,000 - 2,300 rpm

6. Place control lever in "R" range and repeat above test (same as in "D" range).

If stall test indicates proper stall revolution in "D" range, no further testing is necessary.

STALL TEST ANALYSIS

1. Satisfactory results in "D" range indicates forward clutch (Rear), one-

way clutch of transaxle, and sprag clutch of torque converter, are functioning properly.

2. Stall revolution in "D" range, 1st gear, is above the vehicle's specified revolution:

The forward clutch (Rear) is faulty.

3. Stall revolution in "R" range is above specified revolution (for "D" range):

Low and Reverse Brakes are faulty.

4. Stall revolution in "D" range, 1st

gear is below specified revolution:

Converter one-way clutch is faulty (slipping), or engine is not performing properly.

If converter one-way clutch is frozen, vehicle will have poor high speed performance. If converter one-way clutch is slipping, vehicle will be sluggish up to 50 or 60 km/h (30 or 40 MPH).

TROUBLE-SHOOTING CHART

Numbers are arranged in order of probability. Perform inspections starting with number one and working up. Circled numbers indicate that the transaxle must be removed from the car.

	ON CAR											OFF CAR											
	Oil level	Control cable	Inhibitor switch and wiring	Throttle wire	Detent valve	Engine idling rpm	Line pressure	Manual valve	Governor	Band servo	Transaxle air check	Oil quality	Ignition switch and starter motor	Engine adjustment, brake inspection	Forward clutch (Rear)	High-reverse clutch (Front)	Band brake	Low and reverse brake	Oil pump	Oil passage leak	Transaxle on-way clutch	High-reverse clutch (Front) check ball	Park linkage
Engine does not start in "N", "P" ranges.	.	2	3	1
Engine starts in range other than "N" and "P".	.	1	2
Transaxle noise in "P" and "N" ranges.	1	2	3
Car moves when changing into "P" range or parking gear does not disengage when shifted out of "P" range	.	1	2
Car runs in "N" range.	.	1	3	.	.	.	2	.	.	4
Car will not run in "R" range (but runs in "D", "2" and "1" ranges.) Clutch slips. Very poor acceleration.	1	2	3	5	.	.	6	4	.	.	9	8	.	7	.	10	.	11	.
Car braked when shifting into "R" range.	3	2	1	.	.	.	4	.	5	6
Sharp shock in shifting from "N" to "D" range.	.	.	.	2	.	1	3	4	5
Car will not run in "D" range (but runs in "2", "1" and "R" ranges).	.	1	2	3	4
Car will not run in "D", "1", "2" ranges (but runs in "R" range). Clutch slips. Very poor acceleration.	1	2	4	5	.	.	6	3	.	7	8	10	.	.	.	9	.	.	.
Clutches or brakes slip somewhat in starting.	1	2	.	6	.	.	3	5	.	.	7	4	8	9
Excessive creep.	1
No creep at all.	1	2	.	.	.	3	.	5	.	.	.	4	.	.	8	9	.	.	6	7	.	.	.
Failure to change gear from "1st" to "2nd".	.	1	.	2	3	.	.	5	6	8	7	4	.	.	.	9	.	.	10
Failure to change gear from "2nd" to "3rd".	.	1	.	2	3	.	.	5	6	8	7	4	.	.	.	9	.	.	10	.	.	11	.
Too high a gear change point from "1st" to "2nd", from "2nd" to "3rd".	.	.	.	1	2	.	3	5	6	.	.	4	7
Gear change directly from "1st" to "3rd" occurs.	2	4	.	3	1	.	.	.	5	.	.	6
Engine stops when shifting lever into "D" range.	1

Numbers are arranged in order of probability. Perform inspections starting with number one and working up. Circled numbers indicate that the transaxle must be removed from the car.

	ON CAR										OFF CAR								
	Oil level	Control cable Throttle wire	Detent valve	Line pressure	Engine stall rpm	Manual valve	Governor	Band servo	Transaxle air check	Oil quality	Engine adjustment, brake inspection	Forward clutch (Rear)	High-reverse clutch (Front)	Band brake	Low and reverse brake	Oil pump	Oil passage leak	Transaxle one-way clutch	High-reverse clutch (Front) check ball
Too sharp a shock in change from "1st" to "2nd".	. . 1	. . 2	4 . 5	. 3 .	. . ⑥
Too sharp a shock in change from "2nd" to "3rd".	. . 1	. 2 .	3 . 5	4 . .	. ⑥
Almost no shock or clutches slipping in change from "1st" to "2nd".	1 2 3	. 4 .	6 . 8	7 5 .	. . ⑨
Almost no shock or slipping in change from "2nd" to "3rd". Engine races extremely fast.	1 2 3	. 4 .	6 . 8	7 5 .	. ⑨ ⑪
Car braked by gear change from "1st" to "2nd".	2 . .	. 1 .	. ④ ⑤ .
Car braked by gear change from "2nd" to "3rd".	3 . 2	. 1 .	. . ④
Maximum speed not attained. Acceleration poor.	1 2 .	. 4 5	7 . 6	. 3 8	⑪ ⑫ ⑨	⑩ ⑬
Failure to change gear from "3rd" to "2nd".	. . 1	. . .	3 4 6	5 2 .	. ⑦ ⑧
Failure to change gear from "2nd" to "1st" or from "3rd" to "1st".	. . 1	. . .	3 4 6	5 2 .	. . ⑦ ⑧ .
Gear change shock felt during deceleration by releasing accelerator pedal.	. 1 2	3 4 .	5 6
Too high a change point from "3rd" to "2nd", from "2nd" to "1st".	. 1 2	3 4 .	5 6
Kickdown does not operate when depressing pedal in "3rd" within kickdown car speed.	. . 2	1 . .	4 5 .	. 3 .	. . ⑥
Kickdown operates or engine over-runs when depressing pedal in "3rd" beyond kickdown car speed limit.	. 1 2	. 3 .	5 6 .	7 4 .	. ⑧
Races extremely fast or slips in changing from "3rd" to "2nd" when depressing pedal.	. . 1	. 2 .	4 . 6	5 3 .	. ⑦ ⑧ ⑩

Numbers are arranged in order of probability. Perform inspections starting with number one and working up. Circled numbers indicate that the transaxle must be removed from the car.

	ON CAR						OFF CAR															
	Oil level	Control cable	Throttle wire	Engine idling rpm	Line pressure	Engine stall rpm	Lubrication	Manual valve	Governor	Band servo	Transaxle air check	Oil quality	Forward clutch (Rear)	High-reverse clutch (Front)	Band brake	Low and reverse brake	Oil pump	Oil passage leak	Torque converter, one-way clutch	Transaxle one-way clutch	Park linkage	Planetary gear
Car will not run in any range.	1 2 .			. 3 .			. 5 .			. 6 4		 ⑦ ⑧			. . ⑨			. .
Transmission noise in "D", "2", "1" and "R" ranges.	1 . .			. 2			③ . .			. ④ .			. ⑤ .			⑥
Failure to change from "3rd" to "2nd" when changing lever into "2" range.	. 1 .			. 2 .			. 4 .		5 . 3				. . ⑥			. . ⑦		
Gear change from "2nd" to "3rd" in "2" range.	. 1 .			. 2 .			. 3
No shock at change from "1" to "2" range or engine races extremely fast.	1 2 3			4 . 5			. 7 .		. 8 6				. . ⑨			. ⑩
Failure to change from "3rd" to "2nd" when shifting lever into "1" range.	. 1 .			. 2 .			. 4 5		7 6 3				. ⑧ ⑨			. . ⑩		
Engine brake does not operate in "1" range.	. 1 .			. 2 .			. 4 .		. 5 3				. . .			⑥ . ⑦		
Gear change from "1st" to "2nd" or from "2nd" to "3rd" in "1" range.	. 1 2 ⑧		
Does not change from "2nd" to "1st" in "1" range.	1 2 4 5		6 7 3				. . .			⑧ . ⑨		
Large shock changing from "2nd" to "1st" in "1" range.	. . 1			. . 2			. 4 .		. . 3				. . .			⑤
Transaxle overheats.	1 . .			. 3 4			2 6 .		8 7 5				. ⑨ ⑩			⑪ ⑫ ⑬			⑭ . .			⑮
Oil shoots out during operation. White smoke emitted from exhaust pipe during operation.	1 . 3			. 5 6			2 7 .		. 8 4				. ⑨ ⑩			⑪ ⑫ ⑬			⑭ . .			⑮
Offensive smell at oil charging pipe.	1 2				③ ④ ⑤			⑥ ⑦ ⑧			⑨ . .			⑩

ROAD TEST SYMPTOM CHART

		SHIFT QUALITY								COMMENTS	
		ROUGH	SHIFT TIMING [Mark km/h (MPH)]	NO SHIFT	SHIFT SLIPPAGE	CAR WON'T MOVE	CRUISE SLIPPAGE	POOR POWER/ACCELERATION	NOISY		OK
PARK RANGE	ENG. START										
	HOLDING										
"R" RANGE	Man. shift P-R										
	REVERSE										
"N" RANGE	Man. shift R-N										
	ENG. START										
	N										
"D" RANGE	Man. shift N-D										
	1st										
	Auto shift 1-2										
	2nd										
	Auto shift 2-3										
	3rd										
	Decel. 3-2										
	Kickdown 3-2										
	Decel. 2-1										
Kickdown 2-1											
"2" RANGE	Man. shift D-2										
	1st										
	Auto shift 1-2										
	2nd										
	Decel. 2-1										
Kickdown 2-1											
"1" RANGE	Man. shift 2-1										
	Man. shift D-1										
	Acceleration										
	"1" Engine Braking	X									
		X									

TROUBLE-SHOOTING GUIDE FOR RN3F01A AUTOMATIC TRANSAXLE

Order	Test item	Procedure
Checking	<ol style="list-style-type: none"> 1. Oil level gauge 2. Control cable 3. Inhibitor switch 4. Engine idling rpm. 5. Throttle wire 6. Operation in each range. 7. Creep of car. 	<p>Check gauge for oil level and leakage before and after each test.</p> <p>Check by shifting into “P”, “R”, “N”, “D”, “2” and “1” ranges with selector lever.</p> <p>Check whether starter operates in “N” and “P” ranges only and whether reverse lamp operates in “R” range only.</p> <p>Check whether idling rpm meet standard.</p> <p>Check whether the throttle wire is adjusted properly.</p> <p>Check whether transmission engages positively by shifting “N” → “D”, “N” → “2”, “N” → “1” and “N” → “R” range while idling with brake applied.</p> <p>Check whether there is any creep in “D”, “2”, “1” and “R” ranges.</p>
Stall test	<ol style="list-style-type: none"> 1. Oil pressure before testing. 2. Stall test. 3. Oil pressure after testing 	<p>Measure line pressures in “D”, “2”, “1” and “R” range while idling.</p> <p>Measure engine rpm and line pressure in “D”, “2”, “1” and “R” ranges during full throttle operation.</p> <p style="text-align: center;">Temperature of torque converter oil used in test should be from 60 to 100°C (140 to 212°F) i.e., sufficiently warmed up but not overheated.</p> <hr/> <p>CAUTION: To cool oil between each stall test for “D”, “2”, “1” and “R” ranges, idle engine, i.e., rpm at about 1,200 rpm for more than 1 minute in “P” range. Measurement time must not be more than 5 seconds.</p> <hr/> <p>Same as item 1.</p>
Road test	<ol style="list-style-type: none"> 1. Slow acceleration, 1st → 2nd 2nd → 3rd 2. Quick acceleration, 1st → 2nd 2nd → 3rd 3. Kickdown operation, 3rd → 2nd or 2nd → 1st 4. Shift down, D₃ → D₂ → D₁ 	<p>Check car speeds and engine rpm in shifting up 1st → 2nd range and 2nd → 3rd range while running with lever in “D” range and accelerator pedal half-way down.</p> <p>Same as item 1 above except with accelerator pedal more than 7/8 down (i.e., in the position just before kickdown).</p> <p>Check whether the kickdown operates and measure the time delays while running at 30, 40, 50, 60, 70 km/h (19, 25, 31, 37, 43 MPH) in “D₃” range.</p> <p>Check car speeds and engine rpm in shifting down from 3rd → 2nd → 1st (sequentially) while coasting with accelerator pedal released and in “D₃” range with accelerator pedal half-way down.</p>

Trouble-Shooting and Diagnoses – AUTOMATIC TRANSAXLE

Order	Test item	Procedure
Road test	5. Shift down, $D_3 \rightarrow 1_2 \rightarrow 1_1$ 6. Shift down, $D_3 \rightarrow 2$ 7. Shift up and down $2_2 \rightarrow 2_1 \rightarrow 2_2$ 8. Shift up, $1_1 \rightarrow 1_2$ 9. Parking	<p>Check for shifting down $D_3 \rightarrow 1_2$ and engine braking, and further for shifting down $1_2 \rightarrow 1_1$ and engine braking after shifting the lever into "1" range with the accelerator pedal released and while driving at about 60 km/h (37 MPH) in "D₃" range.</p> <p>Check for quick shifting down $D_3 \rightarrow 2$ and engine braking, after shifting the lever into "2" range while driving at about 50 km/h (30 MPH) in "D₃" range.</p> <p>Check for shifting up and down between 2_2 and 2_1 in response to car speed.</p> <p>Check for failure of the transaxle to shift up during acceleration, when starting in "1" range.</p> <p>Confirm that car will not move on grade when shifting to "P" range.</p>
Others	Abnormal shock, oil leakage.	Enter into record conditions observed during these tests such as gear noise, abnormal clutch noise and acceleration performance.

SERVICE DATA AND SPECIFICATIONS (S.D.S.)

GENERAL SPECIFICATIONS

Automatic transaxle model		RN3F01A
Stall torque ratio		1.9 : 1
Transaxle gear ratio	1st	2.826
	2nd	1.543
	Top	1.000
	Reverse	2.364
	Final drive	3.364
Number of teeth	Output shaft	22
	Idler gear	30
	Final gear	74
Oil		Automatic transmission fluid "Dexron" type
Oil capacity		6.0 liters (6-3/8 US qt, 5-1/4 Imp qt)

SPECIFICATIONS AND ADJUSTMENT

Automatic transaxle assembly Model code number		03X11		
High-reverse clutch (Front)	Number of drive plates	2		
	Number of driven plates	3		
	Clearance mm (in)	Standard	1.0 - 1.4 (0.039 - 0.055)	
		Allowable limit	2.2 (0.087)	
	Drive plate thickness mm (in)	Standard	1.50 - 1.65 (0.0591 - 0.0650)	
		Allowable limit	1.4 (0.055)	
	Thickness of retaining plate	Thickness mm (in)	Part number	
3.6 (0.142)		31537-01X00		
3.8 (0.150)		31537-01X01		
4.0 (0.157)		31537-01X02		
4.2 (0.165)		31537-01X03		
4.4 (0.173)	31537-01X04			

Forward clutch (Rear)	Number of drive plates		4	
	Number of driven plates		4	
	Clearance mm (in)	Standard	0.8 - 1.2 (0.031 - 0.047)	
		Allowable limit	2.8 (0.110)	
	Drive plate thickness mm (in)	Standard	1.50 - 1.65 (0.0591 - 0.0650)	
		Allowable limit	1.4 (0.055)	
Thickness of retaining plate	Thickness mm (in)	Part number		
	3.6 (0.142)	31537-01X00		
	3.8 (0.150)	31537-01X01		
	4.0 (0.157)	31537-01X02		
	4.2 (0.165)	31537-01X03		
4.4 (0.173)	31537-01X04			
Low & reverse brake	Number of drive plates		5	
	Number of driven plates		4	
	Clearance mm (in)	Standard	1.90 - 2.20 (0.0748 - 0.0866)	
		Allowable limit	3.8 (0.150)	
	Drive plate thickness mm (in)	Standard	1.90 - 2.05 (0.0748 - 0.0807)	
		Allowable limit	1.8 (0.071)	
	Thickness of retaining plate	Thickness mm (in)	Part number	
3.6 (0.142)		31667-01X00		
3.8 (0.150)		31667-01X01		
4.0 (0.157)		31667-01X02		
4.2 (0.165)		31667-01X03		
4.4 (0.173)	31667-01X04			
Brake band				
Piston size mm (in)	Big dia.	68 (2.68)		
	Small dia.	40 (1.57)		

Oil pump clearance mm (in)	Outer gear-pump housing	Standard	0.05 - 0.20 (0.0020 - 0.0079)
		Allowable limit	0.25 (0.0098)
	Outer gear-crescent	Standard	0.14 - 0.21 (0.0055 - 0.0083)
		Allowable limit	0.25 (0.0098)
	Gears-pump plate	Standard	0.02 - 0.04 (0.0008 - 0.0016)
		Allowable limit	0.08 (0.0031)
Seal ring-groove	Standard	0.15 - 0.25 (0.0059 - 0.0098)	
	Allowable limit	0.25 (0.0098)	
Planetary carrier	Clearance between pinion washer and planetary carrier mm (in)	Standard	0.20 - 0.70 (0.0079 - 0.0276)
		Allowable limit	0.80 (0.0315)

ROTARY FRICTIONAL FORCE

Unit: N·m (kg·cm, in·lb)

Output shaft	0.35 - 0.47 (3.6 - 4.8, 3.1 - 4.2)
Final drive	5.9 - 7.4 (60 - 75, 52 - 65)

OUTPUT SHAFT END PLAY

0.25 - 0.55 mm (0.0098 - 0.0217 in)

AVAILABLE SHIMS

Output shaft tapered roller bearing

Thickness mm (in)	Part number
0.11 (0.0043)	31499-01X00
0.13 (0.0051)	31499-01X01
0.15 (0.0059)	31499-01X02
0.17 (0.0067)	31499-01X03
0.19 (0.0075)	31499-01X04
0.30 (0.0118)	31499-01X05
0.40 (0.0157)	31499-01X06
0.50 (0.0197)	31499-01X07
0.60 (0.0236)	31499-01X08
0.70 (0.0276)	31499-01X09
0.80 (0.0315)	31499-01X10
0.90 (0.0354)	31499-01X11
1.20 (0.0472)	31499-01X12

Output shaft end play

Thickness of soldering plate -0.05 mm (0.0020 in) *	Thickness mm (in)	Part number
0.55 - 0.85 (0.0217 - 0.0335)	0.3 (0.012)	31484-01X00
0.75 - 1.05 (0.0295 - 0.0413)	0.5 (0.020)	31484-01X01
0.95 - 1.25 (0.0374 - 0.0492)	0.7 (0.028)	31484-01X02
1.15 - 1.45 (0.0453 - 0.0571)	0.9 (0.035)	31484-01X03
1.35 - 1.65 (0.0531 - 0.0650)	1.1 (0.043)	31484-01X04
1.55 - 1.85 (0.0610 - 0.0728)	1.3 (0.051)	31484-01X05
1.75 - 2.05 (0.0689 - 0.0807)	1.5 (0.059)	31484-01X06
1.95 - 2.25 (0.0768 - 0.0886)	1.7 (0.067)	31484-01X07

* 0.05 mm (0.0020 in) is the amount the soldering plate recovers due to its elasticity, and it must be subtracted from the thickness of soldering plate.

Final drive

H = A – B mm (in)	Thickness mm (in)	Part number
0 - 0.07 (0 - 0.0028)	0.38 (0.0150)	38454-01X00
0.07 - 0.15 (0.0028 - 0.0059)	0.46 (0.0181)	38454-01X01
0.15 - 0.23 (0.0059 - 0.0091)	0.54 (0.0213)	38454-01X02
0.23 - 0.31 (0.0091 - 0.0122)	0.62 (0.0244)	38454-01X03
0.31 - 0.39 (0.0122 - 0.0154)	0.70 (0.0276)	38454-01X04
0.39 - 0.47 (0.0154 - 0.0185)	0.78 (0.0307)	38454-01X05
0.47 - 0.55 (0.0185 - 0.0217)	0.86 (0.0339)	38454-01X06
0.55 - 0.63 (0.0217 - 0.0248)	0.94 (0.0370)	38454-01X07
0.63 - 0.71 (0.0248 - 0.0280)	1.02 (0.0402)	38454-01X08
0.71 - 0.79 (0.0280 - 0.0311)	1.10 (0.0433)	38454-01X09
0.79 - 0.87 (0.0311 - 0.0343)	1.18 (0.0465)	38454-01X10
0.87 - 0.95 (0.0343 - 0.0374)	1.26 (0.0496)	38454-01X11
0.95 - 1.03 (0.0374 - 0.0406)	1.34 (0.0528)	38454-01X12
1.03 - 1.11 (0.0406 - 0.0437)	1.42 (0.0559)	38454-01X13
1.11 - 1.19 (0.0437 - 0.0469)	1.50 (0.0591)	38454-01X14
1.19 - 1.27 (0.0469 - 0.0500)	1.58 (0.0622)	38454-01X15
1.27 - 1.35 (0.0500 - 0.0531)	1.66 (0.0654)	38454-01X16

STALL REVOLUTION

Stall revolution	rpm	2,000 - 2,300
------------------	-----	---------------

TIGHTENING TORQUE

Unit	N-m	kg-m	ft-lb
Drive plate to torque converter	49 - 69	5.0 - 7.0	36 - 51
Converter housing to engine	16 - 22	1.6 - 2.2	12 - 16
Transaxle case to converter housing	14 - 18	1.4 - 1.8	10 - 13
Transaxle case to front cover	14 - 18	1.4 - 1.8	10 - 13





Unit	N-m	kg-m	ft-lb
Oil pan to transaxle case	5 - 7	0.5 - 0.7	3.6 - 5.1
Bearing retainer to transaxle case	19 - 25	1.9 - 2.5	14 - 18
Piston stem (when adjusting band brake)	*4 - 5	*0.4 - 0.5	*2.9 - 3.6
Piston stem lock nut	16 - 22	1.6 - 2.2	12 - 16
Low and reverse brake piston retainer	7 - 9	0.7 - 0.9	5.1 - 6.5
Control valve body to transaxle case	7 - 9	0.7 - 0.9	5.1 - 6.5
Lower valve body to upper valve body	7 - 9	0.7 - 0.9	5.1 - 6.5
Final gear bolt	69 - 78	7.0 - 8.0	51 - 58
Oil strainer to lower valve body	5 - 7	0.5 - 0.7	3.6 - 5.1
Governor valve body to governor shaft	5 - 7	0.5 - 0.7	3.6 - 5.1
Governor shaft securing nut	3.4 - 6.9	0.35 - 0.7	2.5 - 5.1
Idler gear when adjusting turning frictional force)	26 - 36	2.7 - 3.7	20 - 27
Idler gear lock nut	**		
Throttle wire securing nut	5 - 7	0.5 - 0.7	3.6 - 5.1
Control cable securing nut	8 - 11	0.8 - 1.1	5.8 - 8.0
Inhibitor switch to transaxle case	2.0 - 2.5	0.20 - 0.26	1.4 - 1.9
Manual shaft lock nut	31 - 42	3.2 - 4.3	23 - 31
Oil cooler pipe to transaxle case	29 - 49	3.0 - 5.0	22 - 36
Test plug (oil pressure inspection hole)	5 - 10	0.5 - 1.0	3.6 - 7.2
Support actuator (parking rod inserting position) to rear extension	8 - 11	0.8 - 1.1	5.8 - 8.0
Engine to gusset	30 - 40	3.1 - 4.1	22 - 30
Gusset to converter housing	16 - 21	1.6 - 2.1	12 - 15

* Turn back 2.5 turns after tightening.

** Refer to Adjusting Turning Frictional Force of Tapered Roller Bearing.

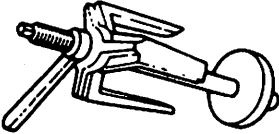
SPECIAL SERVICE TOOLS

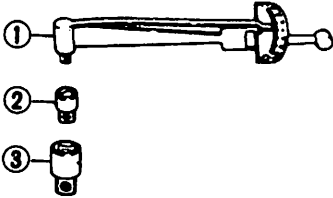
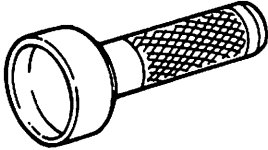
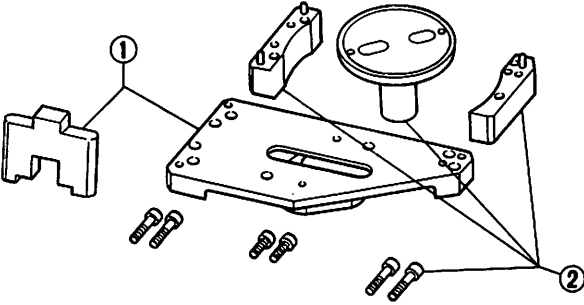
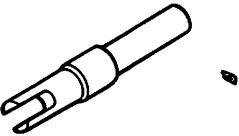
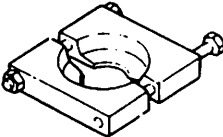
*: Special tool or a commercial equivalent

Tool number (Kent-Moore No.)	Tool name
ST25420001 (ST25420000) (J26063)	Clutch spring compressor 
ST33290001* (J25810)	Side bearing outer race puller 
ST3127S000 (See J25765) ① GG91030000 (J25765) ② HT62940000 (-) ③ HT62900000 (-)	Preload gauge Torque wrench Socket adapter Socket adapter 
ST33400001* (J26082)	Oil seal drift 
KV381058S0 (-) ① KV38105810 (-) ② KV38105820 (-)	Differential side bearing height gauge Differential side bearing height gauge Spacer and bolts 
KV38105900 (-)	Preload adapter 
ST22730000* (J25681)	Bearing puller 
ST2505S001* (J25695)	Oil pressure gauge set 

AUTOMATIC TRANSAXLE – *Special Service Tools*

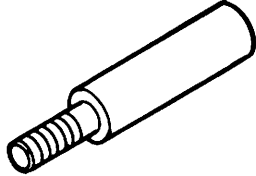
Tool number (Kent-Moore No.)	Tool name
KV38106000 (-)	Height gauge adapter (diff. side bearing) 

STARTING SYSTEM

SCHEMATIC

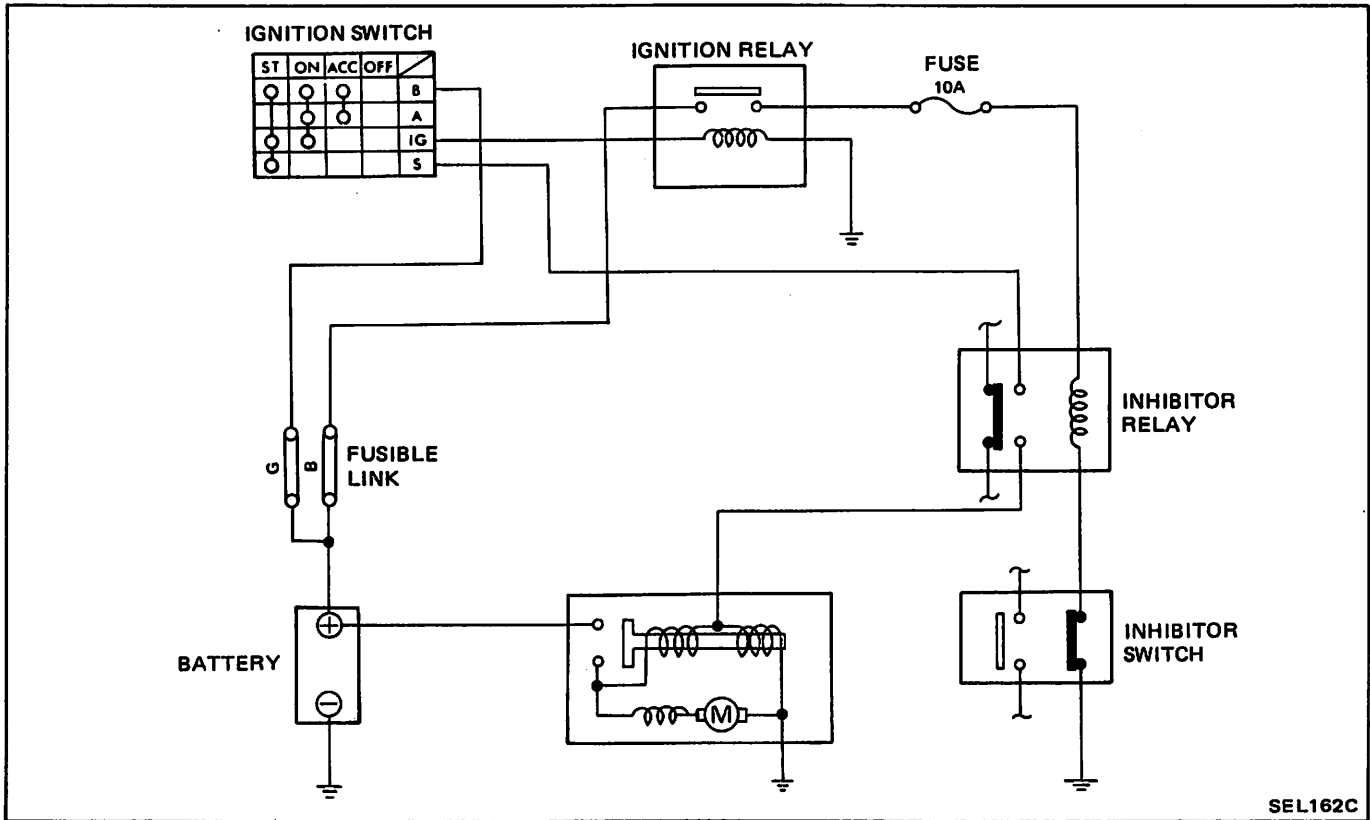

WIRING DIAGRAM

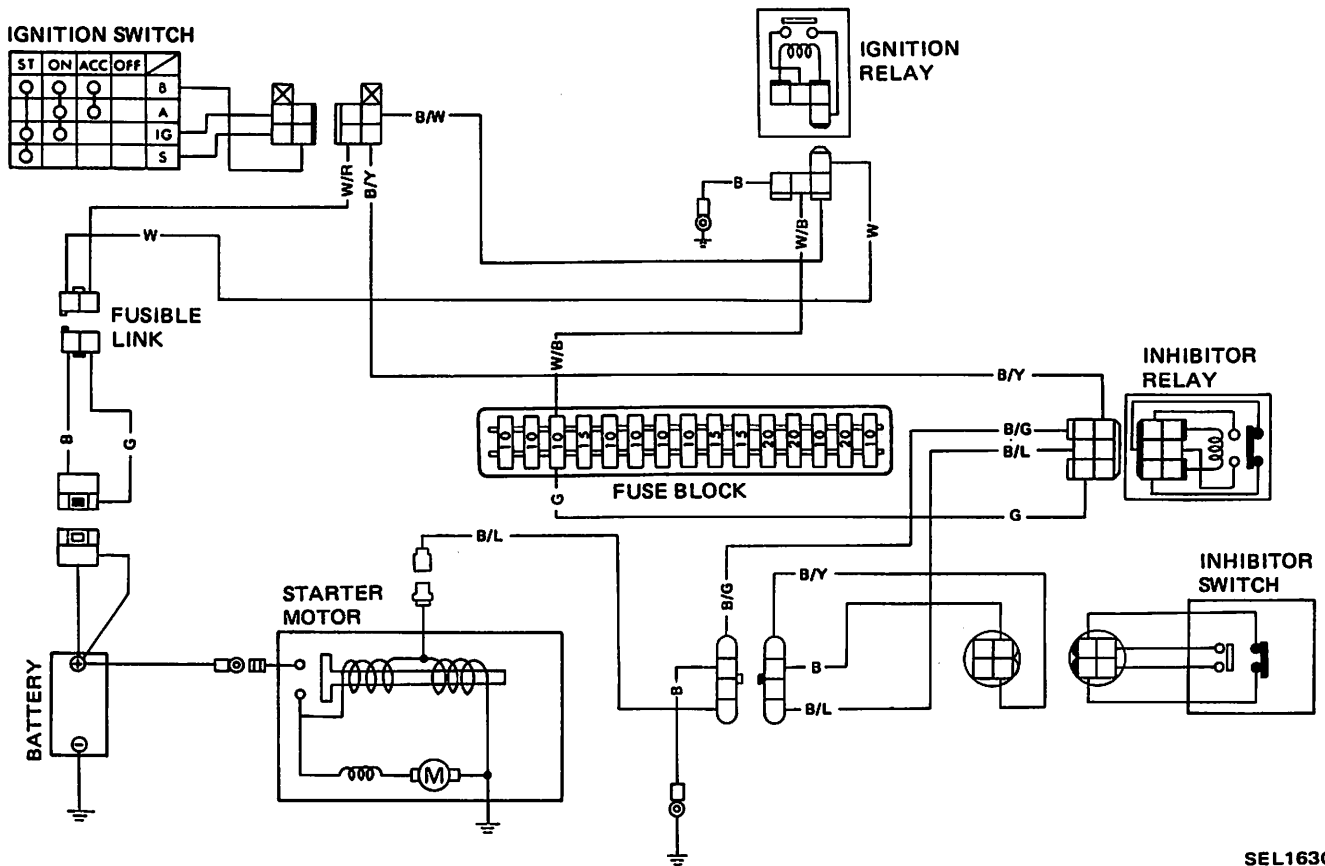

IGNITION SYSTEM

DISTRIBUTOR

SERVICE DATA AND SPECIFICATIONS (S.D.S.)

Type	D4N80-30	D4N80-31
Applied model	Federal and Canada	California
Firing order	1-3-4-2	
Rotating direction	Counterclockwise	
Air gap mm (in)	0.3 - 0.5 (0.012 - 0.020)	
Cap insulation resistance MΩ	More than 50	
Rotor head insulation resistance MΩ	More than 50	
Cap carbon point length mm (in)	10 (0.39)	
Vacuum advance [Distributor degree/distributor kPa (mmHg, inHg)]	0/9.3 (70, 2.76) 6.5/13.3 (100, 3.94) 6.5/16.0 (120, 4.72) 17.5/40.0 (300, 11.81)	0/9.3 (70, 2.76) 6.5/13.3 (100, 3.94) 6.5/16.0 (120, 4.72) 12.5/40.0 (300, 11.81)
Centrifugal advance [Distributor degree/distributor rpm]	0/600 10.5/2,400	

AUTOMATIC SPEED CONTROL DEVICE (A.S.C.D.)

CAUTION: Before starting to work, be sure to turn ignition switch "OFF" and then disconnect battery ground cable.

DESCRIPTION

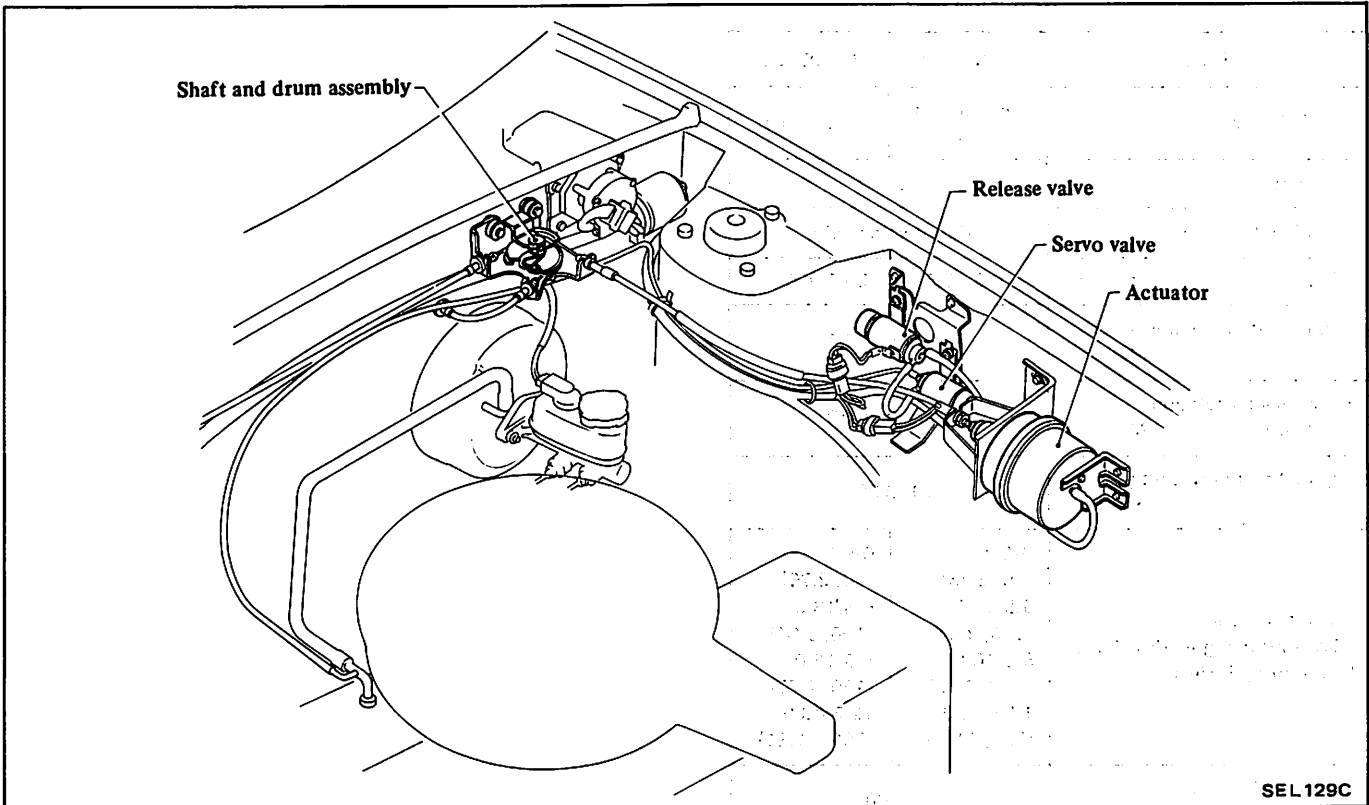

SCHEMATIC/A.S.C.D.

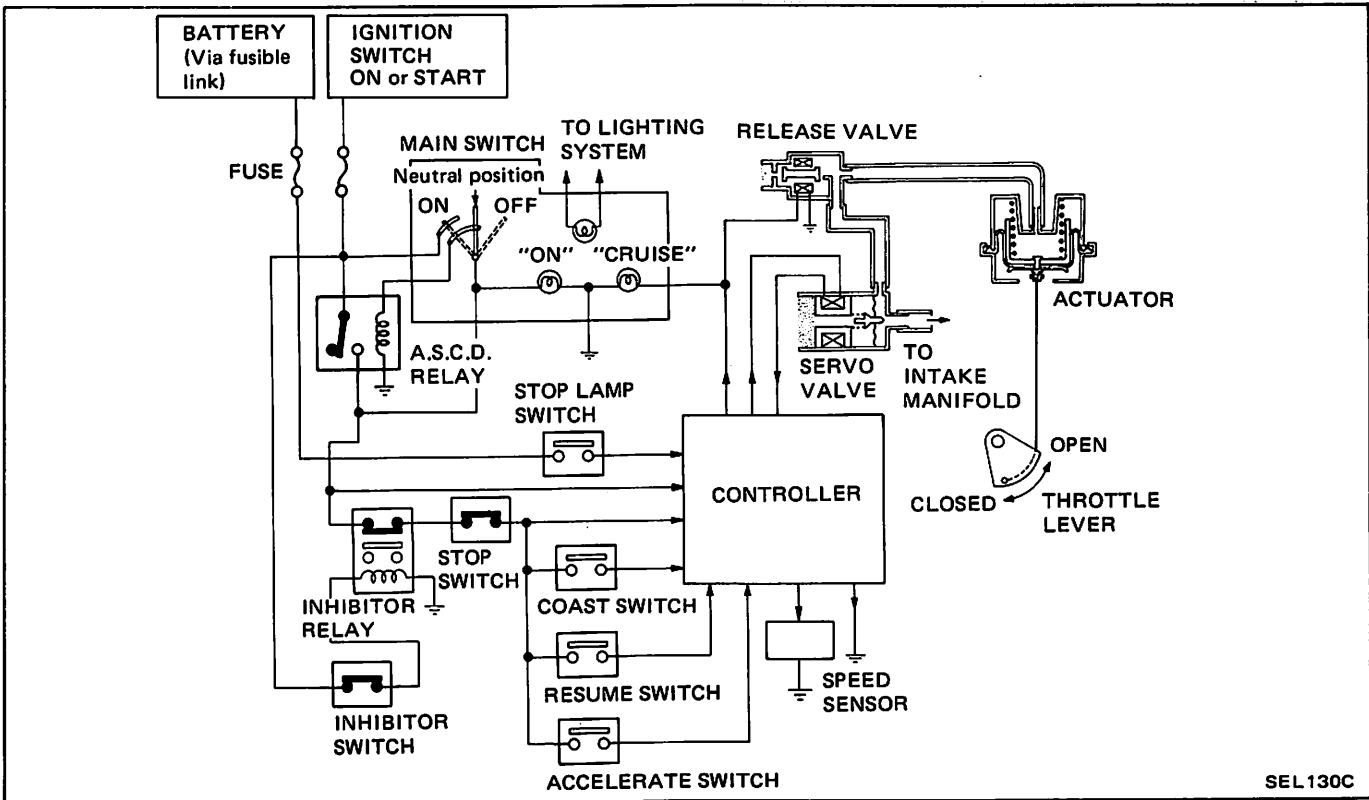

FUNCTION AND OPERATION

MAIN SWITCH

The main switch has a holding type of circuit.

When the main switch is turned ON with the ignition switch ON, the exciting coil of the relay will be energized and the relay will turn ON, thus supplying current to the system. Although the main switch automatically returns to its original position, the current is sent through the relay and fed to the exciting coil via the main switch; in this way, the relay will remain ON. When the ignition switch is turned off, the relay will also turn off. And the relay will remain inoperative until the main switch is turned ON, even if the ignition switch is set to ON.

COAST SWITCH

The coast switch has an ON-OFF switch type of circuit.

When the coast switch is depressed, the CRUISE light illuminates. With the switch depressed, the controller cancels the preset car speed.

The controller will preset the car speed at which the car is running when the switch is released.

ACCELERATE & RESUME SWITCH

The accelerate & resume switch is designed to increase the set speed, or to return it to that speed at which the car was previously being driven before the set speed was cancelled by depression of the brake pedal, etc.

Depressing the "ACCEL" end of the switch causes the car speed to in-

crease continuously; releasing it will set the car speed at that which the car is currently being driven. Depressing the "RESUME" end of the switch momentarily causes the car speed to automatically return to the set speed at which the car was being driven before the set speed was cancelled by depression of the brake pedal, etc. Keeping the "RESUME" end pressed causes the car speed to decrease; releasing it will return the car speed to that which the car was being driven before it was released.

SPEED SENSOR (Contained in speedometer)

The speed sensor is an ON-OFF type sensor generating two pulses per revolution of the meter cable.

SERVO VALVE (Transducer)

The servo valve causes the vacuum valve and atmospheric valve to open or close according to the input current and adjusts the vacuum from the intake manifold.

CONTROLLER

The controller compares the preset speed with the actual car speed, and maintains the preset speed by increasing or decreasing the current flowing through the servo valve.

RELEASE VALVE

The release valve is the safety valve which shuts off the atmospheric passage to the vacuum line, when the system activates.

ACTUATOR

The actuator causes the throttle to open and close, by vacuum, through the servo valve.

STOP SWITCH

The stop switch is used to release the system. When the brake pedal is depressed, this switch cuts off the power supply to the A.S.C.D. circuit.

STOP LAMP SWITCH

This switch causes the stop light to operate. At the same time, the operating signal of the stop light circuit is sent to the controller in order to release the system.

INHIBITOR RELAY

The inhibitor relay releases the A.S.C.D. system when the selector is set to "N" or "P" position.

TROUBLE DIAGNOSES

TEST CONDITIONS

If a malfunction is found, be sure to check the following before performing the system test.

1. All wiring harness connectors must be securely connected.
2. A.S.C.D. cable must be securely installed with proper adjustment.
3. Vacuum hoses must be properly attached with no abnormal conditions such as vacuum leakage, sharp bends or kinks.

DIAGNOSES

WARNING:
All following system tests can be performed without running engine. Avoid making test while driving car or running engine.

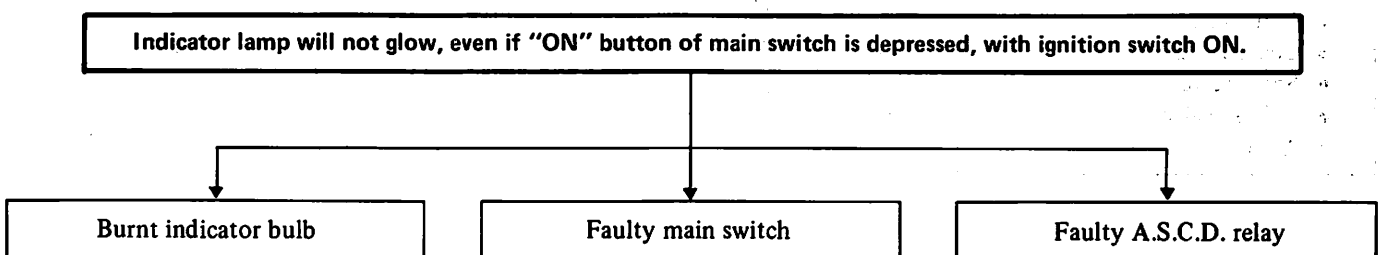

Cruise lamp will not glow, even if set switch is depressed and released at proper car speed, with main switch ON. (Speed not set in system.)

With ignition switch and main switch ON, battery voltage (12V) is present between terminals ③ and ⑦, ⑩ and ⑦ of harness connector.
Set automatic transmission selector lever at any position other than "P" and "N" position.

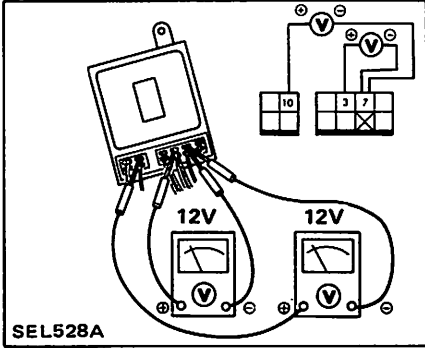

YES

NO

Open circuit.

Faulty or improperly adjusted stop switch.

Faulty inhibitor switch or inhibitor relay.

When set switch is depressed with ignition switch and main switch ON, battery voltage (12V) is present between terminals ② and ⑦ of harness connector.

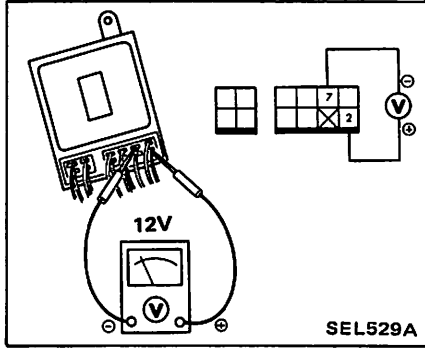

YES

NO

Faulty set switch.

With ignition switch and main switch ON, manually rotate meter cable slowly to see if voltages across harness connector terminals ⑧ and ⑦ alternately change from 0 to 7 and vice versa.

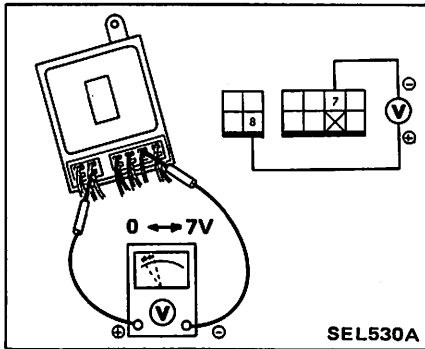

YES

NO

Check the following parts.

- Controller
- Coast switch
- Servo valve
- Release valve
- Actuator

Only 7 volts remain present.

YES

NO

Faulty speed sensor.

Faulty speed sensor or controller.

ELECTRICAL SYSTEM – Automatic Speed Control Device (A.S.C.D.)

Car will not accelerate when "ACCEL" end is depressed. (However, constant car speed can be maintained by A.S.C.D.)

With ignition switch, main switch and accelerate switch ON, battery voltage (12V) is present between terminals ⑫ and ⑦ of harness connector.
Set automatic transmission selector lever at "P" or "N" position.

YES

NO

Faulty accelerate & resume switch.

When only "ACCEL" end is "OFF", voltage across terminals ⑫ and ⑦ will be zero.

YES

NO

Faulty controller.

Faulty accelerate & resume switch.

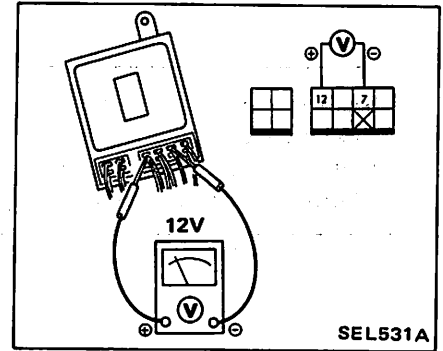

Car will not decelerate when "RESUME" end remains ON, or car speed will not return to speed at which it was being driven before set speed was cancelled when "RESUME" end is depressed momentarily. (However, constant speed can be maintained by A.S.C.D.)

With ignition switch, main switch and resume switch ON, battery voltage (12V) is present between terminals ⑪ and ⑦ of harness connector.
Set automatic transmission selector lever at "P" or "N" position.

YES

NO

Faulty accelerate & resume switch.

When only "RESUME" end is "OFF", voltage across terminals ⑪ and ⑦ will be zero.

YES

NO

Faulty controller.

Faulty accelerate & resume switch.

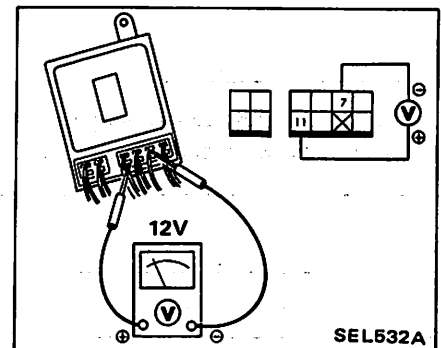

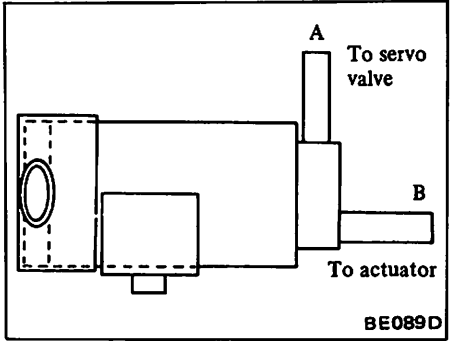
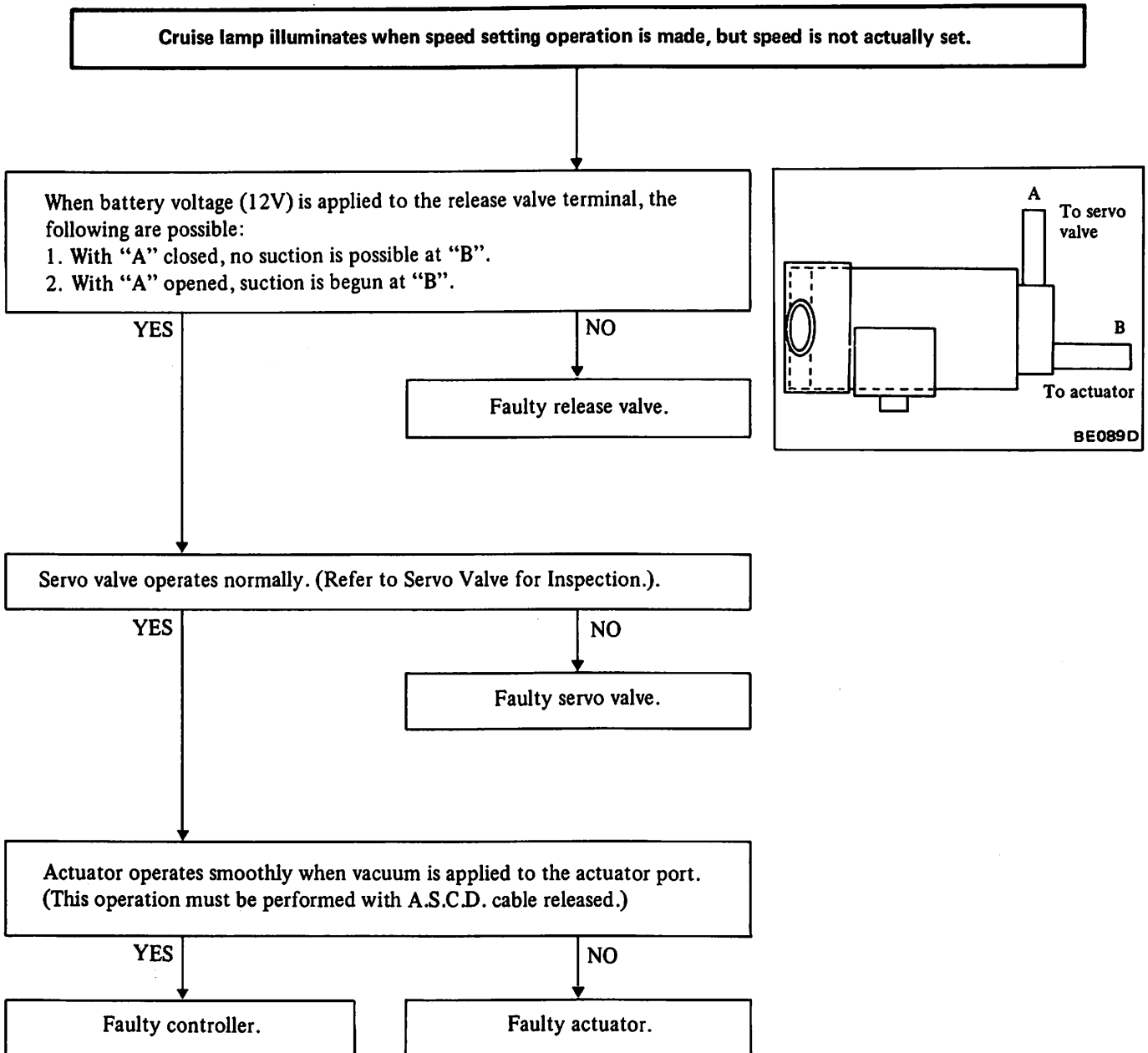

Other malfunction

Condition	Probable cause	Corrective action
Set speed is cancelled.	<ul style="list-style-type: none"> ● Bent meter cable (excessive meter needle deflection.). ● Faulty controller. 	<ul style="list-style-type: none"> ● Check and repair meter cable, or renew cable. ● Renew.
Pulsation of set speed.	<ul style="list-style-type: none"> ● Excessive play or binding of A.S.C.D. cable. ● Leakage or clogging in vacuum hose. ● Binding in actuator. ● Faulty servo valve. ● Faulty controller. 	<ul style="list-style-type: none"> ● Adjust. ● Check and repair piping route, or renew hose. ● Renew actuator. ● Renew servo valve. ● Renew controller.
Excessive setting error.	<ul style="list-style-type: none"> ● Excessive play or binding in A.S.C.D. cable. ● Leakage or clogging in vacuum hose. ● Faulty actuator. ● Faulty servo valve. ● Faulty controller. ● Faulty speed sensor. 	<ul style="list-style-type: none"> ● Readjust. ● Check and repair piping route, or renew hose. ● Renew actuator. ● Renew servo valve. ● Renew controller. ● Renew speed sensor.
Speed drops immediately after setting.	<ul style="list-style-type: none"> ● Excessive play in A.S.C.D. cable. ● Leakage or clogging in vacuum hose. ● Faulty release valve. ● Faulty servo valve. ● Faulty controller. 	<ul style="list-style-type: none"> ● Readjust. ● Check and repair piping route, or renew hose. ● Renew release valve. ● Renew servo valve. ● Renew controller.
Cancel circuit inoperative.	<ul style="list-style-type: none"> ● Faulty controller. 	<ul style="list-style-type: none"> ● Renew controller.

WIRING DIAGRAM/A.S.C.D.

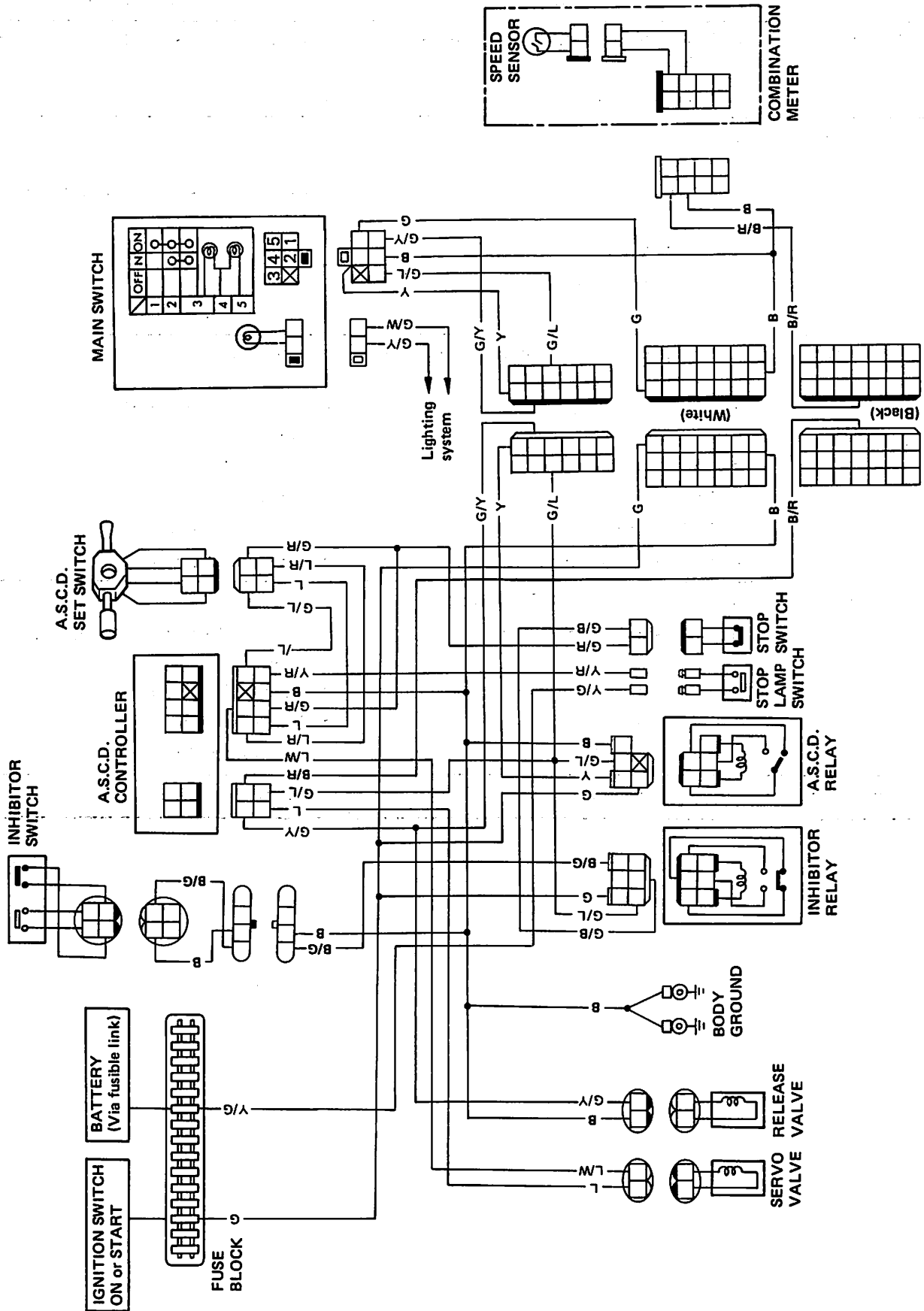

COMPONENT PARTS INSPECTION

A. S. C. D. CABLE

Removal and Installation

1. Disconnect cable from actuator.
- (1) Loosen lock nut at actuator.
- (2) Remove rubber boots.

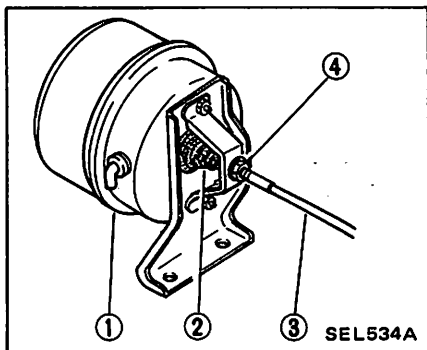

- | | |
|---------------|------------|
| 1 Actuator | 3 Cable |
| 2 Rubber boot | 4 Lock nut |

2. Loosen adjusting nuts at shaft and drum assembly.
3. To install the cable, reverse the order of removal.

Exercise care when removing and installing wire, so as not to deform wire end.

Adjustment

When installing, adjust A.S.C.D. cable as follows:

Without depressing the accelerator pedal, adjust the adjusting nuts until there is no cable free play.

Then return adjusting nuts 1/2 to 1 turn to gain free play.

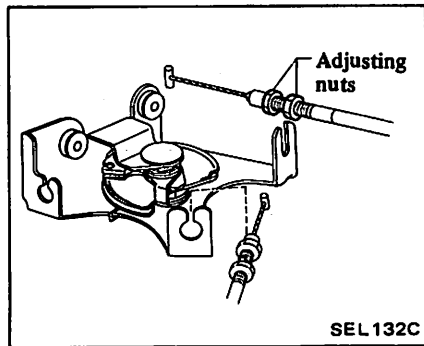

Do not increase tension of cable excessively, as this may cause throttle lever to rotate.

ACTUATOR

Removal and Installation

1. Disconnect battery ground cable.
 2. Disconnect cable from actuator.
- Refer to A.S.C.D. cable for removal.
3. Disconnect vacuum hose from A.S.C.D. release valve.
 4. Remove bolt attaching actuator to body.
 5. To install actuator, reverse the order of removal.

Inspection

1. Visually check actuator for damage or deformation.
2. Make sure that actuator moves smoothly without binding when diaphragm is pushed by hand.
3. Apply vacuum to actuator. If diaphragm moves to full position, it is normal.

Plug hose with vacuum applied. Make sure that actuator remains in full position.

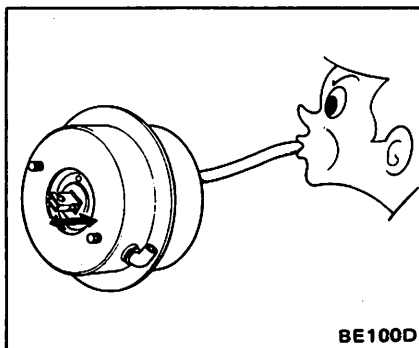

CAUTION:

When applying vacuum to check actuator, do not apply engine vacuum as it is too strong to check actuator properly.

RELEASE VALVE

Location

Refer to page EL-4.

Inspection

1. Measure the resistance between terminals.

Circuit tester indication:

25 - 30 Ω

2. Check to be sure that the valve opens or closes by blowing air through port on actuator side.

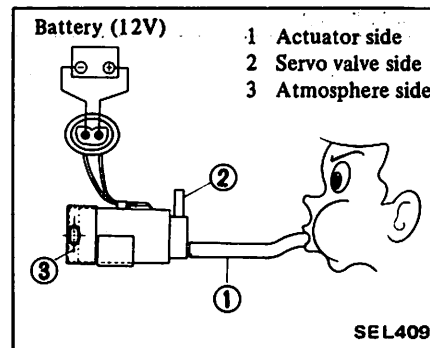

- (1) Normal condition.

Check ports	Air flow
① - ②	Yes
① - ③	
② - ③	

- (2) 12V direct current is applied between terminals.

Check ports	Air flow
① - ②	Yes
① - ③	No
② - ③	

SERVO VALVE

Location

Refer to page EL-4.

Inspection

1. Measure the resistance between terminals.

Circuit tester indication:

25 - 30 Ω

2. Check to be sure that output vacuum of valve is proper.

This check should be performed with the valve installed on car.

CAUTION:

Do not apply current to servo valve with it connected to system. Be sure to disconnect solenoid valve side vacuum hose to prevent a sudden increase in engine speed.

- (1) Disconnect solenoid valve side vacuum hose at servo valve and connect vacuum gauge.
- (2) Start engine and warm up engine until water temperature indicator points to the middle of gauge.

- (3) Apply 0.3A direct current between terminals.

Using about 20Ω-5W variable resistor, adjust so that a current of 0.3A will flow.

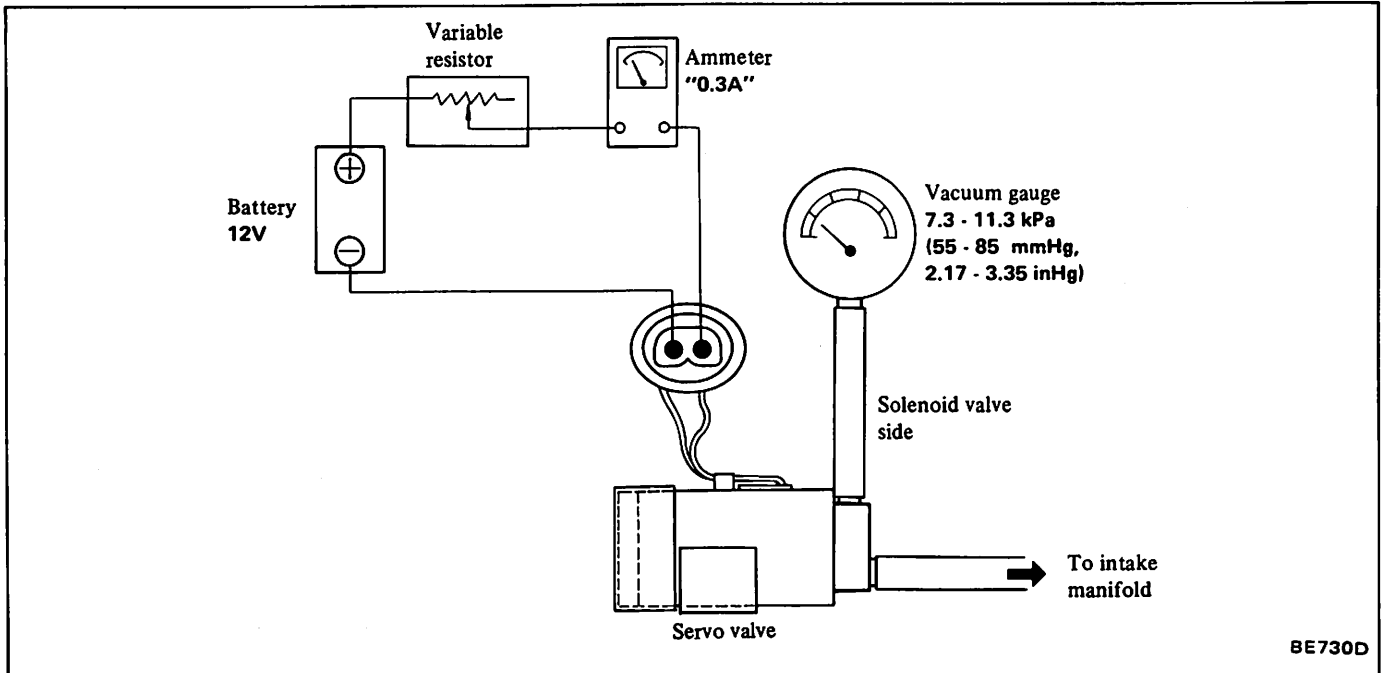

**SPEED SENSOR
(Reed switch type)**

Location

The speed sensor is built into the speedometer.

Inspection

Inspection must be made with speed sensor installed to speedometer.

Turning speedometer slowly by hand, test continuity of speed sensor circuit.

Continuity exists two times a turn O.K.

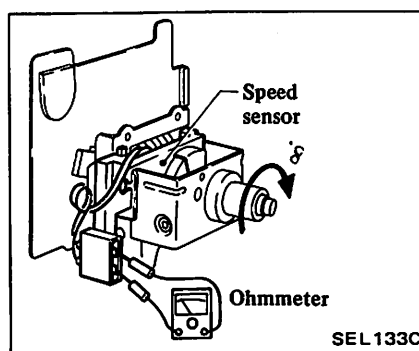

MAIN SWITCH

Inspection

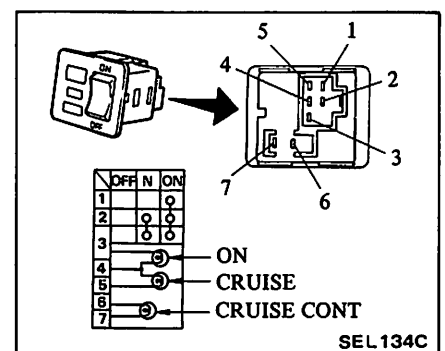

COAST SWITCH AND ACCELERATE & RESUME SWITCH

Inspection

Test continuity through switch with an ohmmeter.

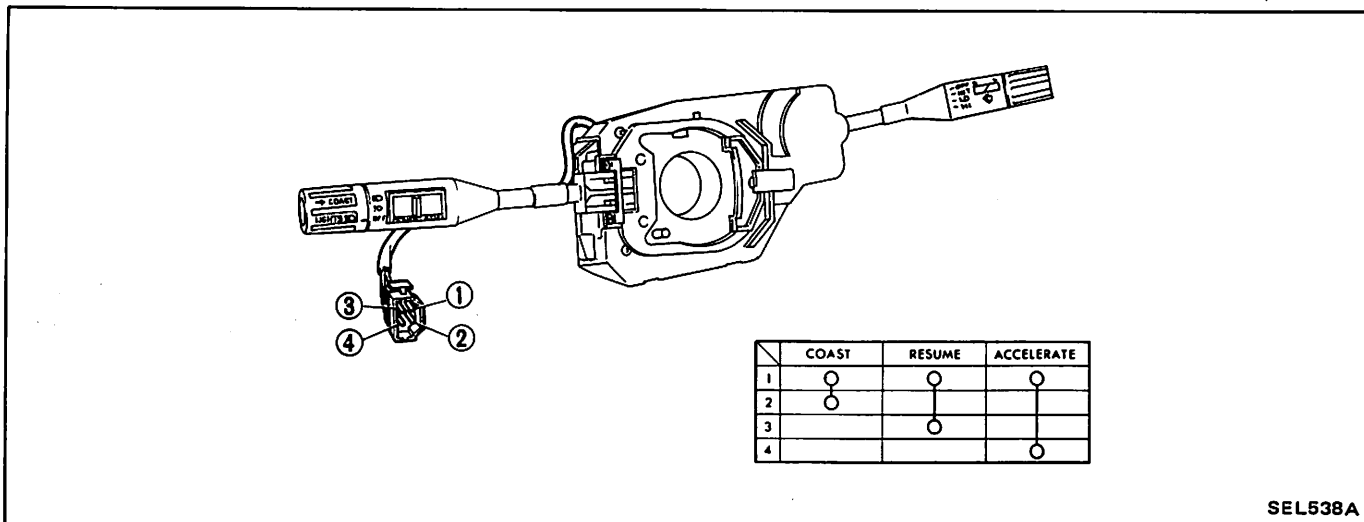

SEL538A

STOP SWITCH

Inspection

Test continuity through switch with an ohmmeter.

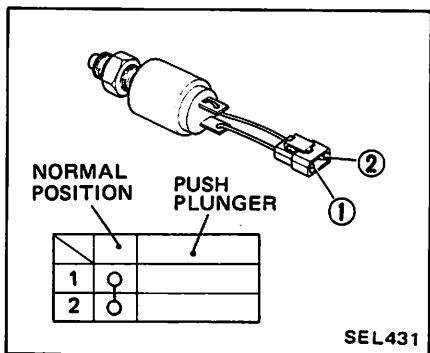

SEL431

Adjustment

Adjustment of the stop switch is the same as the stop lamp switch.

Refer to MA section.

Inspection

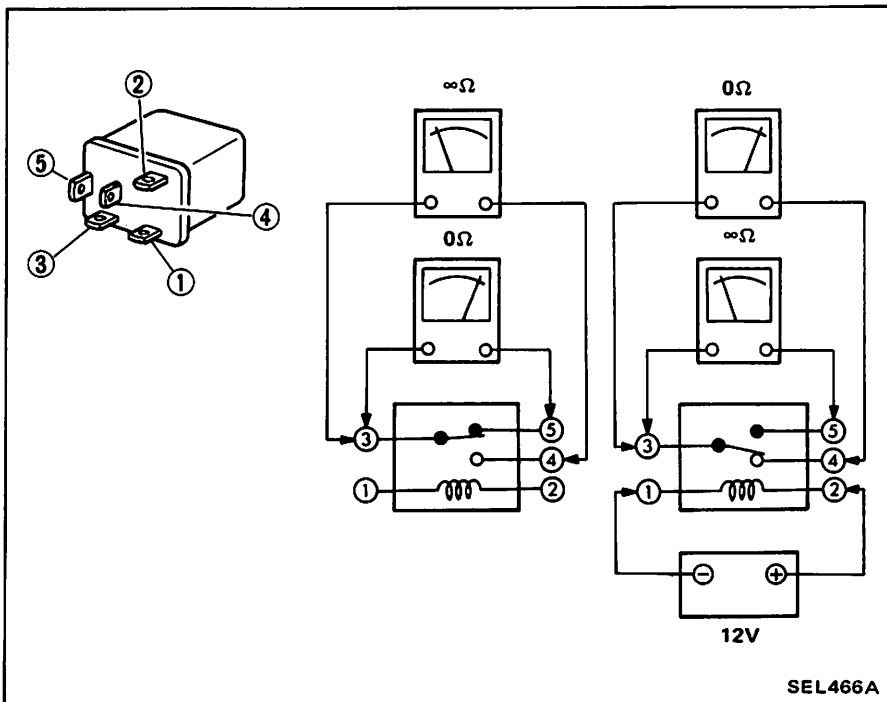

SEL466A

A. S. C. D. RELAY

Location

The A.S.C.D. relay is located on the fuse block. Refer to page EL-16.

INHIBITOR RELAY (For A. S. C. D.)

Location

The inhibitor relay is located on the relay bracket. Refer to page EL-15.

Inspection

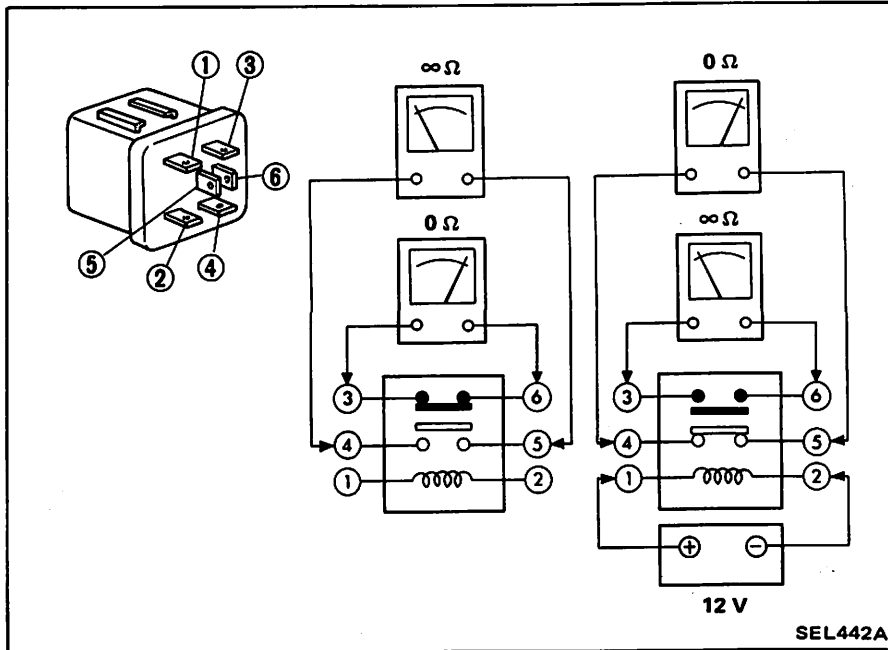

A. S. C. D. CONTROLLER (IC built-in)

Location

The controller is located on the left dash side panel. Refer to page EL-16.

Inspection

Controller must not be checked as a single part. Check controller for operation as a system, referring to Diagnoses.

CAUTION:

Do not touch the circuit tester probe to any unnecessary terminal on controller. Doing so could cause damage to controller.

- Handle controller carefully to avoid damage.
- Keep controller away from electric noise source to prevent A.S.C.D. system from malfunctioning and IC circuit, etc. from being degraded.

LOCATION OF ELECTRICAL UNITS

CAUTION: Before starting to work, be sure to turn ignition switch "OFF" and then disconnect battery ground cable.

ENGINE COMPARTMENT

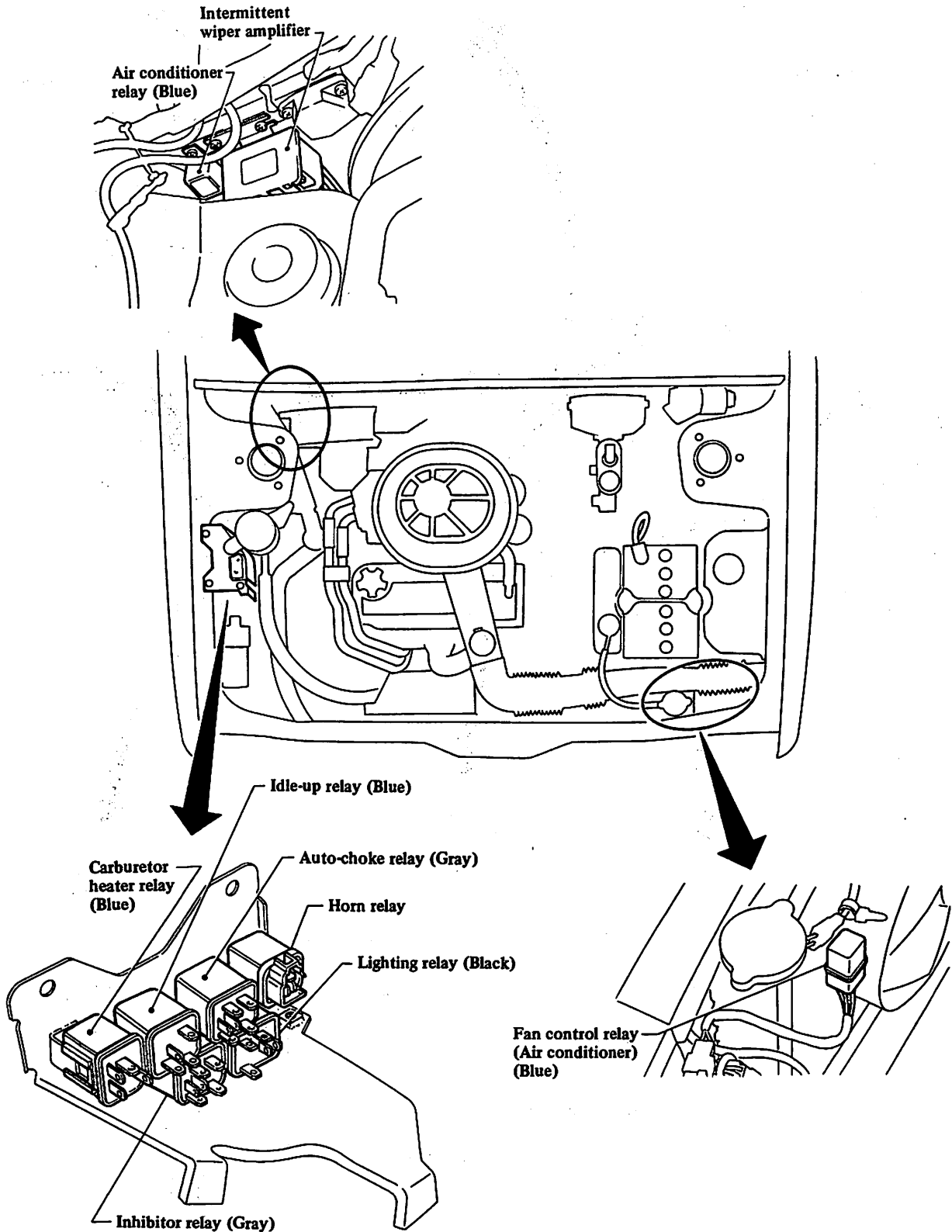

PASSENGER COMPARTMENT

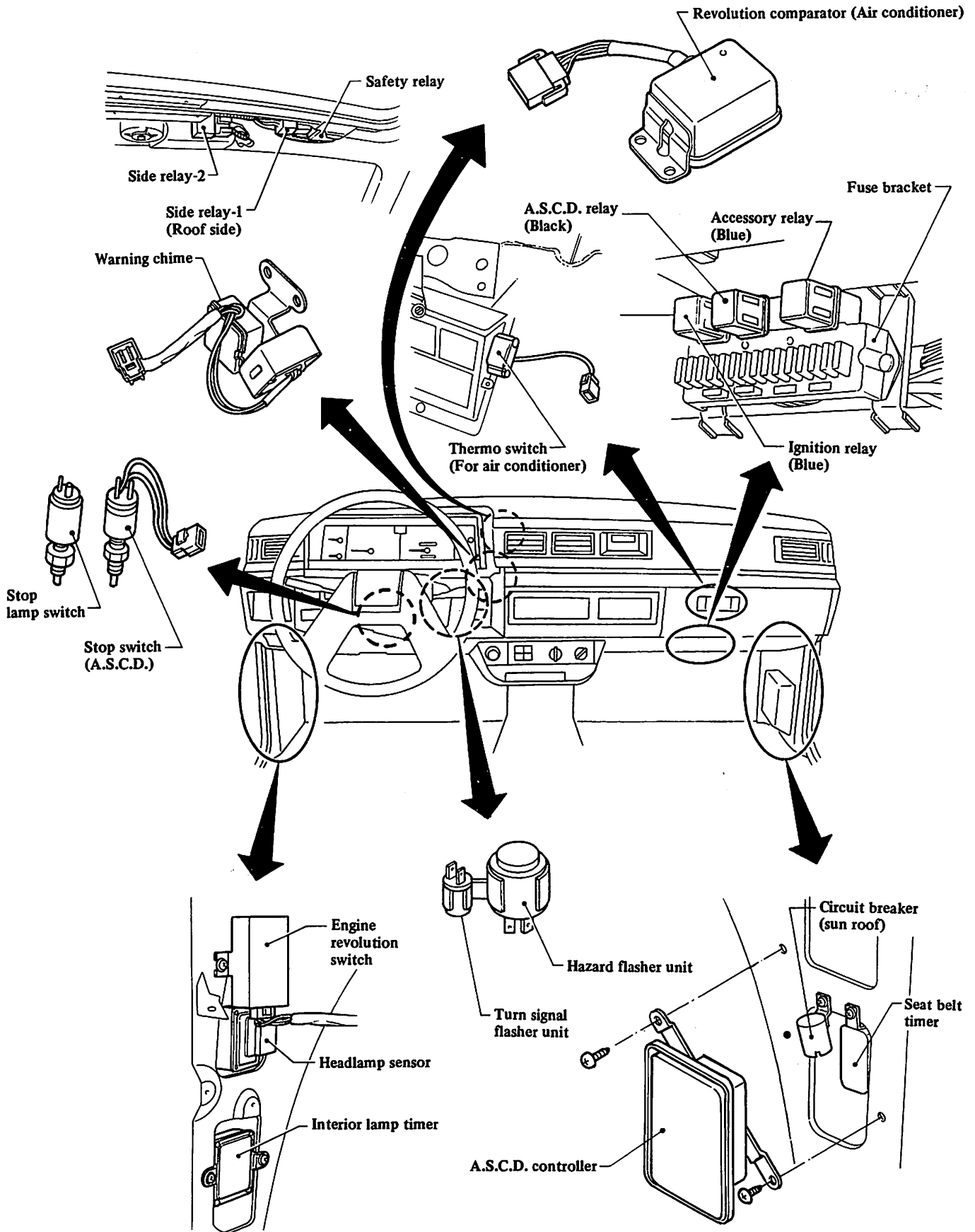

SEL136C

LUGGAGE COMPARTMENT

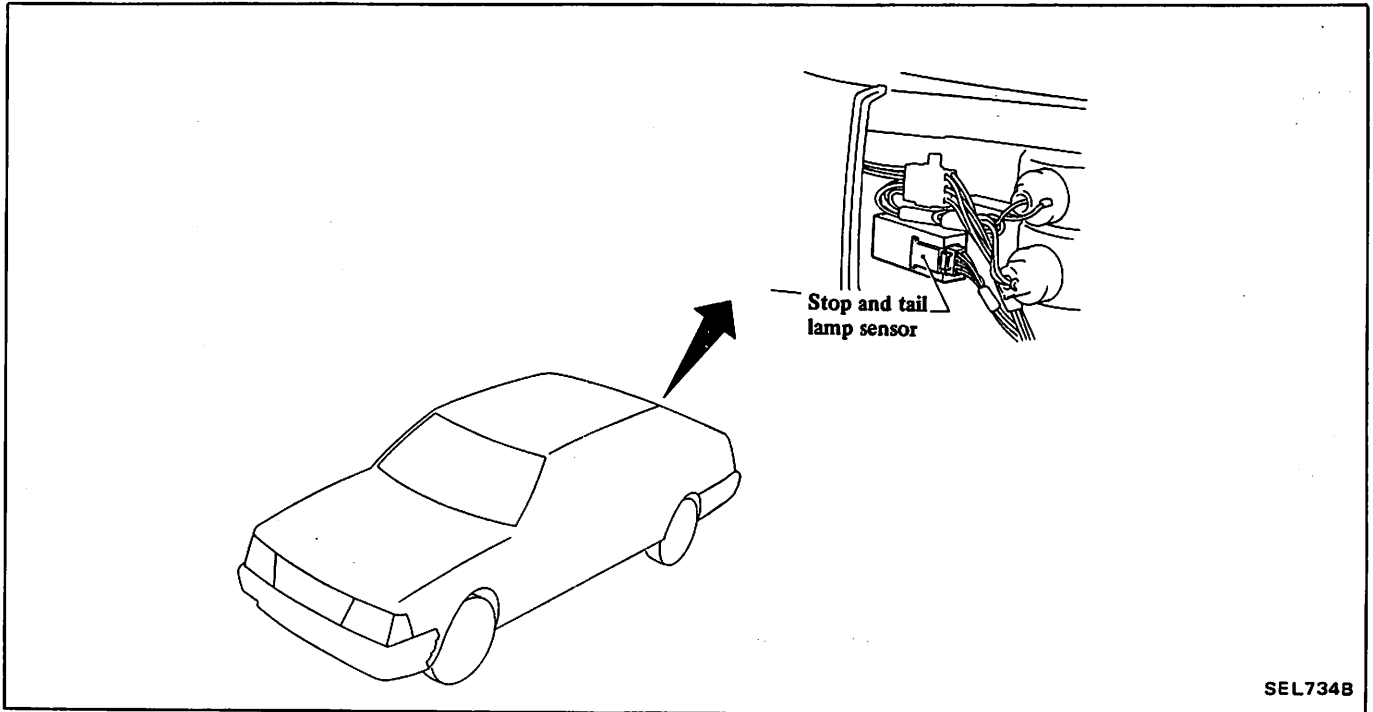

HARNES DIAGRAM

CAUTION: Before starting to work, be sure to turn ignition switch "OFF" and then disconnect battery ground cable.

HOW TO READ HARNES DIAGRAMS

WIRE NUMBER:

For identification, all wires are numbered and generally, numbers are classified by system.

- 100 ~ 199 Engine electrical system
- 200 ~ 299 Headlamp system
- 300 ~ 399 Meter, gauges and Warning system
- 400 ~ 499 Signal system
- 500 ~ 599 Accessory system
- 600 ~ 899 Supplemental numbers
- 900 ~ 999 Ground wire (Earth)

COLOR:

- W White
- B Black
- R Red
- Y Yellow
- G Green
- L Blue
- BR Brown
- LG Light green
- OR Orange
- P Pink
- PU Purple
- GY Gray
- SB Sky blue

In the case of two-tone color wires, the wire colors are indicated as follows.

- B/R Black with Red stripe
- L/OR Blue with Orange stripe

Indicates that No. 406 wire is found only in harness of GL models.

NISSAN

MAIN HARNES

NO.	FROM	TO	REMARKS
203	HEADLAMP	INST H	
204	HEADLAMP	INST H	
406	HORN	408	GL
408	HORN	INST H	
910	HEADLAMP	INST H	

Indicates that No. 406 wire stems from the horn and is connected to No. 408 wire.

For easy identification, connectors indicated in the harness diagrams have the same code numbers as those used in the harness layout and system wiring diagram.

HORN

System wiring diagram

Harness layout

This harness diagram indicates harnesses and connectors to be used with all optional, as well as standard, equipment.

INCH TO METRIC CONVERSION TABLE

(Rounded-off for automotive use)

inches	mm	inches	mm
.100	2.54	.610	15.49
.110	2.79	.620	15.75
.120	3.05	.630	16.00
.130	3.30	.640	16.26
.140	3.56	.650	16.51
.150	3.81	.660	16.76
.160	4.06	.670	17.02
.170	4.32	.680	17.27
.180	4.57	.690	17.53
.190	4.83	.700	17.78
.200	5.08	.710	18.03
.210	5.33	.720	18.29
.220	5.59	.730	18.54
.230	5.84	.740	18.80
.240	6.10	.750	19.05
.250	6.35	.760	19.30
.260	6.60	.770	19.56
.270	6.86	.780	19.81
.280	7.11	.790	20.07
.290	7.37	.800	20.32
.300	7.62	.810	20.57
.310	7.87	.820	20.83
.320	8.13	.830	21.08
.330	8.38	.840	21.34
.340	8.64	.850	21.59
.350	8.89	.860	21.84
.360	9.14	.870	22.10
.370	9.40	.880	22.35
.380	9.65	.890	22.61
.390	9.91	.900	22.86
.400	10.16	.910	23.11
.410	10.41	.920	23.37
.420	10.67	.930	23.62
.430	10.92	.940	23.88
.440	11.18	.950	24.11
.450	11.43	.960	24.38
.460	11.68	.970	24.64
.470	11.94	.980	24.89
.480	12.19	.990	25.15
.490	12.45	1.000	25.40
.500	12.70	2.000	50.80
.510	12.95	3.000	76.20
.520	13.21	4.000	101.60
.530	13.46	5.000	127.00
.540	13.72	6.000	152.40
.550	13.97	7.000	177.80
.560	14.22	8.000	203.20
.570	14.48	9.000	228.60
.580	14.73	10.000	254.00
.590	14.99	20.000	508.00
.600	15.24		

METRIC TO INCH CONVERSION TABLE

(Rounded-off for automotive use)

mm	inches	mm	inches
1	.0394	51	2.008
2	.079	52	2.047
3	.118	53	2.087
4	.157	54	2.126
5	.197	55	2.165
6	.236	56	2.205
7	.276	57	2.244
8	.315	58	2.283
9	.354	59	2.323
10	.394	60	2.362
11	.433	61	2.402
12	.472	62	2.441
13	.512	63	2.480
14	.551	64	2.520
15	.591	65	2.559
16	.630	66	2.598
17	.669	67	2.638
18	.709	68	2.677
19	.748	69	2.717
20	.787	70	2.756
21	.827	71	2.795
22	.866	72	2.835
23	.906	73	2.874
24	.945	74	2.913
25	.984	75	2.953
26	1.024	76	2.992
27	1.063	77	3.031
28	1.102	78	3.071
29	1.142	79	3.110
30	1.181	80	3.150
31	1.220	81	3.189
32	1.260	82	3.228
33	1.299	83	3.268
34	1.339	84	3.307
35	1.378	85	3.346
36	1.417	86	3.386
37	1.457	87	3.425
38	1.496	88	3.465
39	1.535	89	3.504
40	1.575	90	3.543
41	1.614	91	3.583
42	1.654	92	3.622
43	1.693	93	3.661
44	1.732	94	3.701
45	1.772	95	3.740
46	1.811	96	3.780
47	1.850	97	3.819
48	1.890	98	3.858
49	1.929	99	3.898
50	1.969	100	3.937

QUICK REFERENCE CHART: STANZA A/T 1982

ENGINE TUNE-UP DATA

Engine model		CA20	
Firing order		1-3-4-2	
Idle speed rpm		650±100	
M/T	A/T	650±100 (in "D" position)	
Ignition timing (degree B.T.D.C. at idle speed)		0±2° Ignition timing should be checked with distributor vacuum hose disconnected and plugged up.	
"CO" % at idle speed (No air) %		Idle mixture screw is preset and sealed at factory.	
B.C.D.D. operating pressure [At sea level] kPa (mmHg, inHg)		-81.3±2.7 (-610±20, -24.02±0.79)	
Vacuum break [At 25°C (77°F)] mm (in)		3.12 - 3.72 (0.1228 - 0.1465)	
Valve clearance (Hot) mm (in)	Intake	0.3 (0.012)	
	Exhaust	0.3 (0.012)	
Drive belt deflection (Cold) mm (in)		Adjust deflection of used belt	Set deflection of new belt
Alternator		11 - 14 (0.43 - 0.55)	9 - 12 (0.35 - 0.47)
Air conditioner compressor (With A/C)		4 - 6 (0.16 - 0.24)	3 - 5 (0.12 - 0.20)
Idler pulley (Without A/C)		6 - 9 (0.24 - 0.35)	5 - 7 (0.20 - 0.28)
Power steering pump (With air conditioner)		7 - 10 (0.28 - 0.39)	6 - 9 (0.24 - 0.35)
Power steering pump (Without air conditioner)		6 - 9 (0.24 - 0.35)	5 - 8 (0.20 - 0.31)
Applied pressed force N (kg, lb)		98 (10, 22)	
Radiator cap relief pressure kPa (kg/cm ² , psi)		88 (0.9, 13)	
Cooling system leakage testing pressure kPa (kg/cm ² , psi)		157 (1.6, 23)	
High tension cable resistance kΩ		Less than 30	
Spark plug	Type	BPR6ES-11	
	Intake side		
	Exhaust side	BPR5ES-11	
Gap mm (in)	1.0 - 1.1 (0.039 - 0.043)		
Tightening torque		N-m	kg-m
Cylinder head		69 - 78	7.0 - 8.0
Rocker arm nut		16 - 22	1.6 - 2.2
Oil pan drain plug		29 - 39	3.0 - 4.0
Spark plug		15 - 20	1.5 - 2.0
			ft-lb
			51 - 58
			12 - 16
			22 - 29
			11 - 14

BRAKE

Unit: mm (in)

Disc brake		
Pad minimum thickness		2.0 (0.08)
Rotor repair limit		
Runout		Less than 0.15 (0.0059)
Parallelism		
Circumferential direction		Less than 0.03 (0.0012)
Minimum thickness		16 (0.63)
Drum brake		
Lining minimum thickness		1.5 (0.059)
Drum repair limit		
Maximum inner diameter		204.5 (8.05)
Radial runout		Less than 0.10 (0.0039)
Out-of-roundness		Less than 0.02 (0.0008)
Taper		Less than 0.02 (0.0008)

WHEEL ALIGNMENT (Unladen)*

Camber	degree	-45' - 45'
Caster	degree	40' - 2°10'
Toe-in	mm (in)	0 - 2 (0 - 0.08)
	degree	0 - 12' (On both sides)
Turning angle		
Toe-out turns (Inside/Outside)		20°/18.5°
Inside		36° - 40°
Outside		30° - 34°

*: Tankful of fuel, radiator coolant and engine oil full. Spare tire, jack, hand tools, mats in designed position.

REAR WHEEL BEARING

Tightening torque	N-m (kg-m, ft-lb)	39 - 44 (4.0 - 4.5, 29 - 33)
Return angle	degree	90°

WHEEL AND TIRE

Tire size		165SR13	185/70SR13	T125/70D-16
Inflation pressure*	psi (kPa)	26 (180)		
Wheel nut tightening torque	N-m (kg-m, ft-lb)	78 - 98 (8 - 10, 58 - 72)		

*: Tire pressure should be checked when tires are COLD.

REFILL CAPACITIES

	Unit	Liter	US measure
Fuel tank		54	14-1/4 gal
Coolant	With heater	7.3	7-3/4 qt
	Without heater	6.5	6-7/8 qt
Engine	With oil filter	3.9	4-1/8 qt
	Without oil filter	3.5	3-3/4 qt
Transaxle	Automatic	6.0	6-3/8 qt
Power steering system		1.0	1-1/8 qt
Air conditioning system	Compressor oil	0.15	5.1 fl oz
	Refrigerant	0.8 - 1.0 kg	1.8 - 2.2 lb

FINLEY BROS.

DATSUM SALES & SERVICE

1312 NORTHCREST DRIVE

CRESOENT CITY, CALIF. 95531

PH. 464-6189

EXPORT SERVICE DEPARTMENT

NISSAN MOTOR CO., LTD.

17-1, Ginza 6-Chome, Chuo-ku, Tokyo 104, Japan

Printed in Japan

Edition: November 1981

Printing: November 1981 (010520)

Publication No. SM2E-T11SU0