MANUAL TRANSMISSION

	Page
TROUBLESHOOTING	MT-2
G53 TRANSMISSION	MT-3
Removal of Transmission	MT-3
Components	MT-6
Disassembly of Transmission	MT-8
Inspection of Transmission Components	MT-17
Assembly of Transmission	MT-23
Installation of Transmission	MT-36
SHIFT LEVER AND CONTROL CABLE	MT-39

TROUBLESHOOTING

Problem	Possible cause	Remedy	Page
Hard to shift or will not shift	Splines on input shaft dirty or burred Transmission faulty	Repair as necessary Disassemble and inspect transmission	MT-6
Transmission jumps out of gear	Transmission faulty	Disassemble and inspect transmission	MT-6

G53 TRANSMISSION

REMOVAL OF TRANSMISSION

1. DISCONNECT BATTERY CABLE FROM NEGATIVE TERMINAL
2. RAISE VEHICLE
CAUTION: Be sure the vehicle is securely supported.
3. DRAIN TRANSMISSION OIL

4.-1 (2WD) REMOVE PROPELLER SHAFT

- (a) Place the matchmarks on the differential and propeller shaft flanges.
- (b) Remove the four bolts and nuts, disconnect the propeller shaft from the differential.
- (c) Pull out the propeller shaft yoke from the transmission and insert SST into the extension housing.

SST 09325-20010

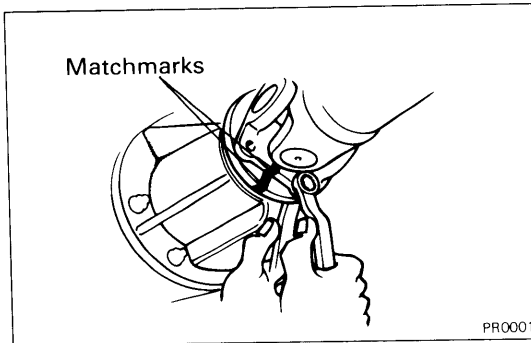

4.-2 (4WD) REMOVE FRONT AND REAR PROPELLER SHAFTS (See page PR-4)

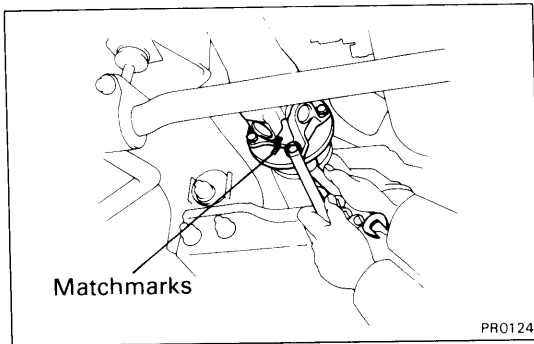

5. DISCONNECT BACK-UP LIGHT SWITCH CONNECTOR

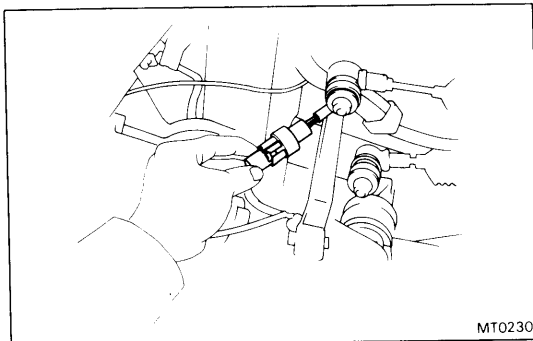

6. (4WD) DISCONNECT TRANSFER INDICATOR SWITCH CONNECTOR

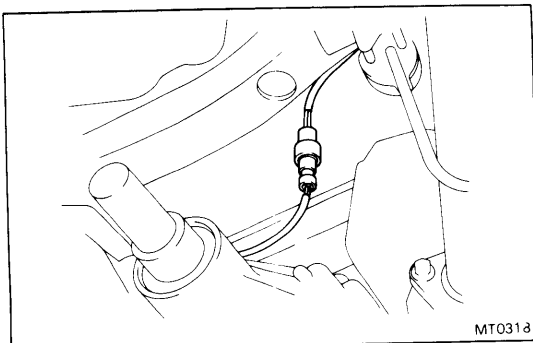

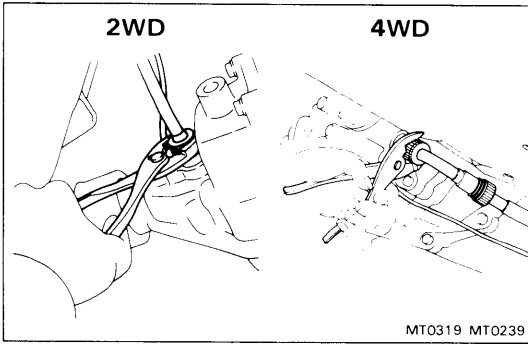

7. DISCONNECT SPEEDOMETER CABLE AND GROUND STRAP

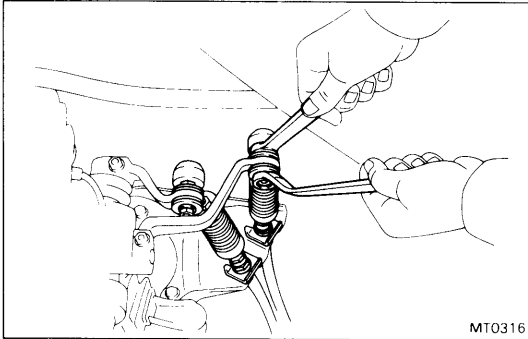

8. DISCONNECT TRANSMISSION CONTROL CABLES

- (a) Remove the nuts.
- (b) Remove the retainers from the bracket.

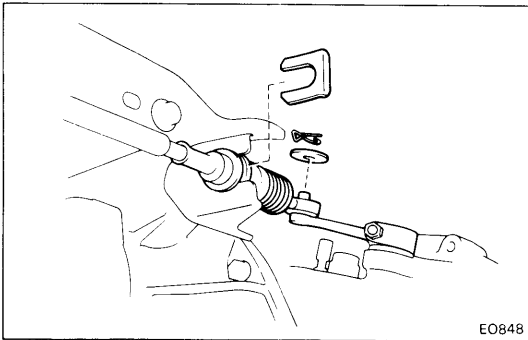

9. (4WD) DISCONNECT TRANSFER CONTROL CABLE

- (a) Disconnect the clip and washer.
- (b) Remove the retainer from the bracket.

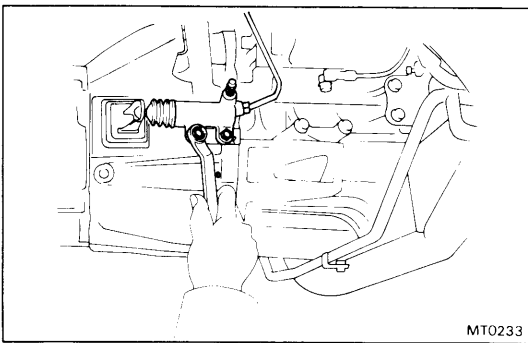

10. REMOVE CLUTCH RELEASE CYLINDER

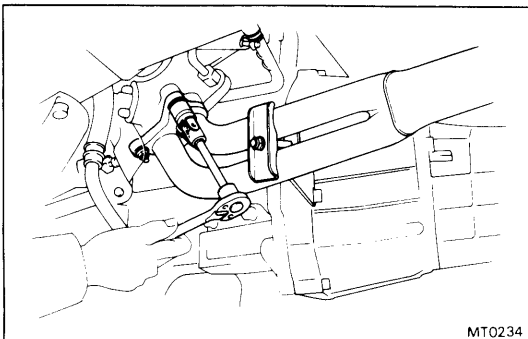

11. DISCONNECT EXHAUST FRONT PIPE

- (a) Remove the exhaust front pipe clamp from the bracket.
- (b) Disconnect the exhaust front pipe from the exhaust manifold.

12. REMOVE STARTER AND CONTROL CABLE BRACKET

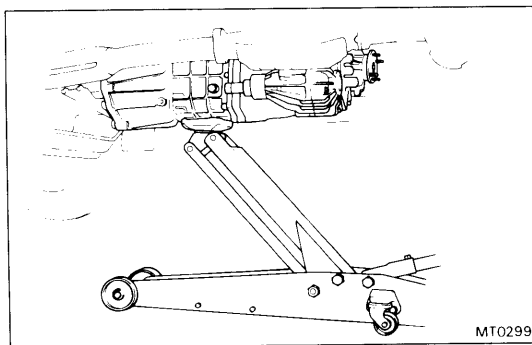

**13.-1 (2WD)
JACK UP TRANSMISSION SLIGHTLY**

Raise the transmission enough to remove the weight from the rear mounting.

**13.-2 (4WD)
JACK UP TRANSMISSION AND TRANSFER SLIGHTLY**

Raise the transmission and transfer enough to remove the weight from the rear mounting.

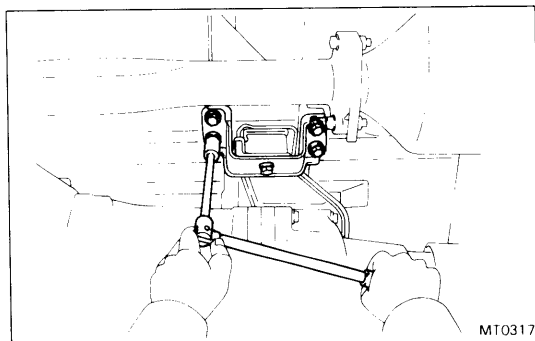

**14.-1 (2WD)
DISCONNECT ENGINE REAR MOUNTING**

**14.-2 (4WD)
REMOVE ENGINE REAR MOUNTING BOLT**

15. REMOVE TRANSMISSION MOUNTING BOLTS

**16.-1 (2WD)
REMOVE TRANSMISSION**

Pull out the transmission down and toward the rear.

**16.-2 (4WD)
REMOVE TRANSMISSION WITH TRANSFER**

Pull out the transmission with the transfer toward the rear.

**17. (4WD)
REMOVE TRANSFER FROM TRANSMISSION**

(a) Remove the engine rear mounting.

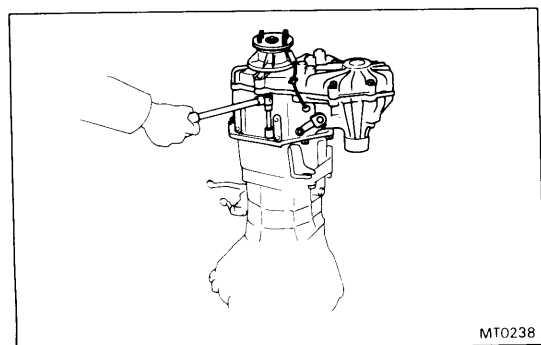
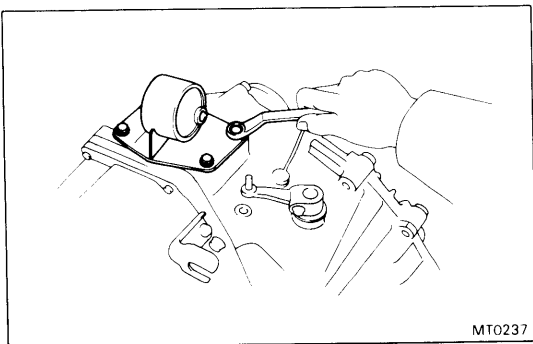
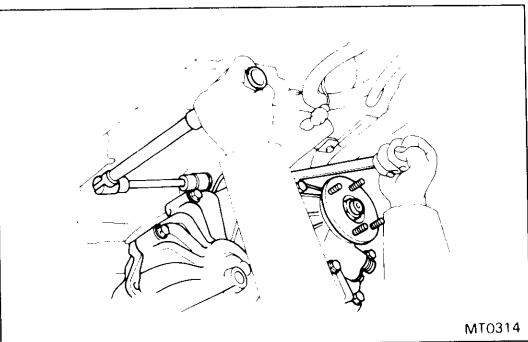

(b) Stand the transmission with the transfer and remove the transfer mounting bolts.

(c) Pull the transfer straight up and remove it from the transmission.

COMPONENTS

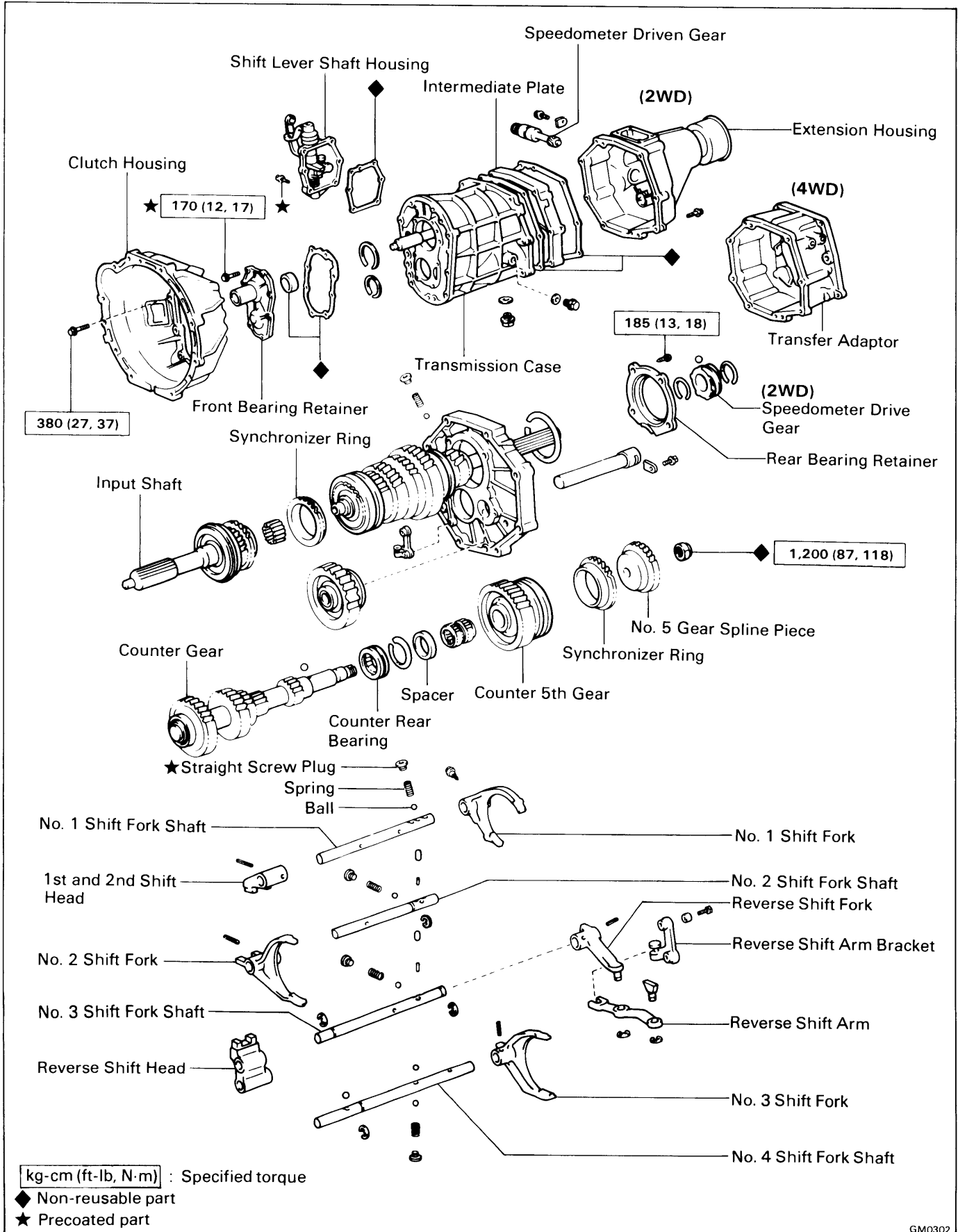

cardiagn.com

COMPONENTS (Cont'd)

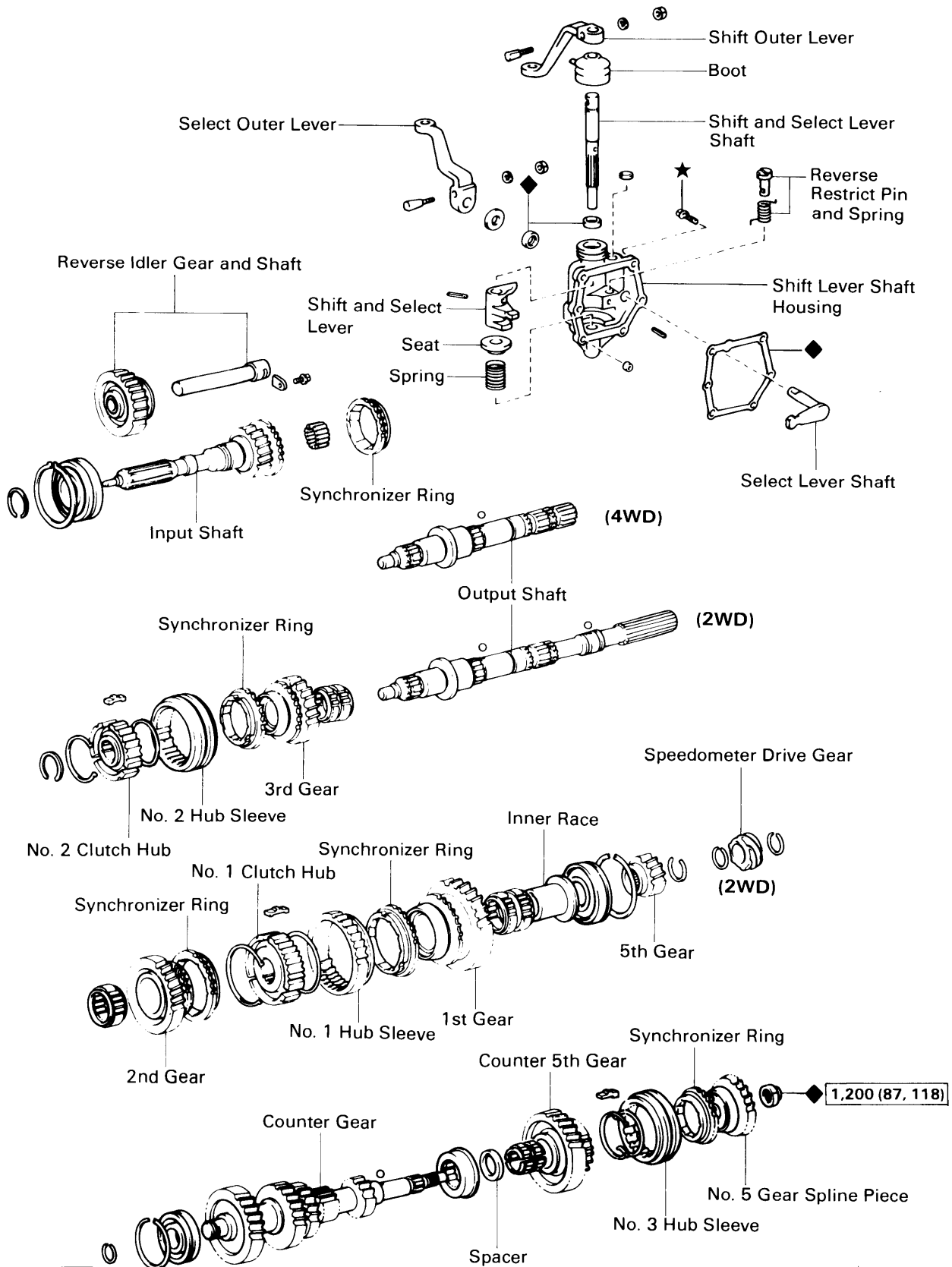

kg-cm (ft-lb, N-m) : Specified torque

◆ Non-reusable part

★ Precoated part

1,200 (87, 118)

DISASSEMBLY OF TRANSMISSION

(See pages MT-6,7)

1. REMOVE RELEASE FORK AND BEARING
2. REMOVE BACK-UP LIGHT SWITCH AND SPEEDOMETER DRIVEN GEAR (2WD)
3. REMOVE CLUTCH HOUSING FROM TRANSMISSION CASE
4. REMOVE SHIFT LEVER SHAFT HOUSING ASSEMBLY

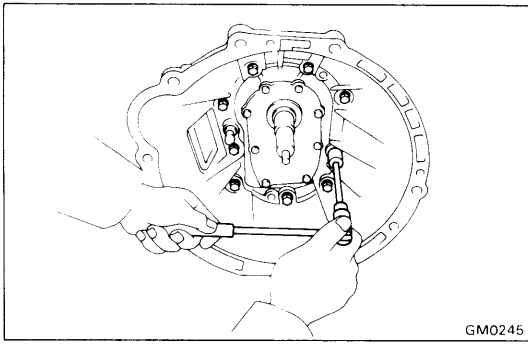

GM0245

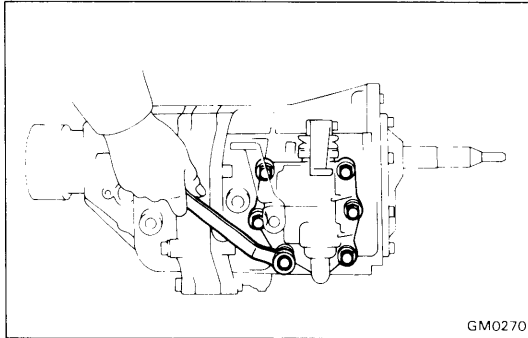

GM0270

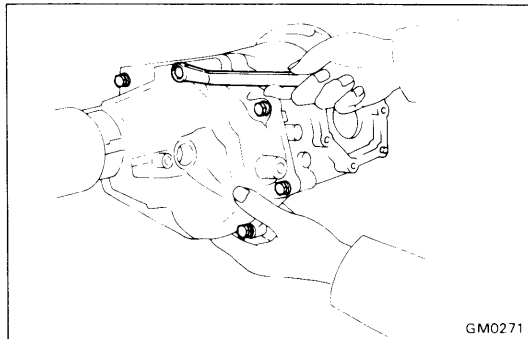

GM0271

- 5.-1 (2WD)
REMOVE EXTENSION HOUSING

NOTE: Leave the gasket attached to the intermediate plate.

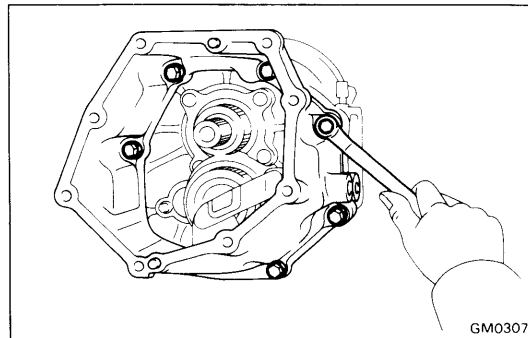

GM0307

- 5.-2 (4WD)
REMOVE TRANSFER ADAPTOR

NOTE: Leave the gasket attached to the intermediate plate.

6. REMOVE FRONT BEARING RETAINER

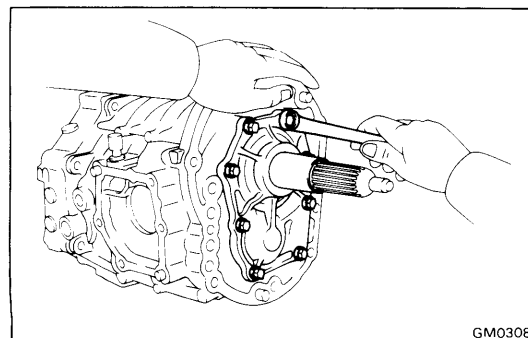

GM0308

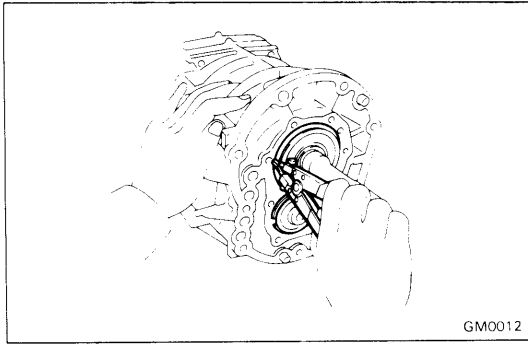

7. REMOVE BEARING SNAP RINGS

Using snap ring pliers, remove the two snap rings.

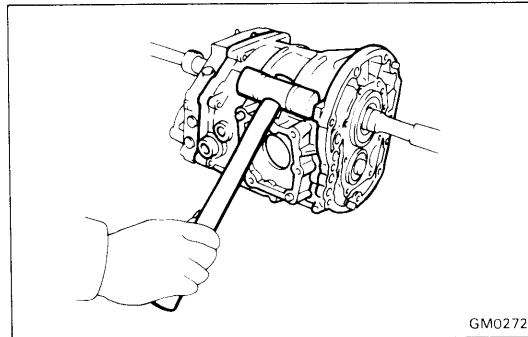

8. SEPARATE INTERMEDIATE PLATE FROM TRANSMISSION CASE

- (a) Using a plastic hammer, carefully tap off the transmission case.
- (b) Remove the transmission case from the intermediate plate.

NOTE: Leave the gasket attached to the intermediate plate.

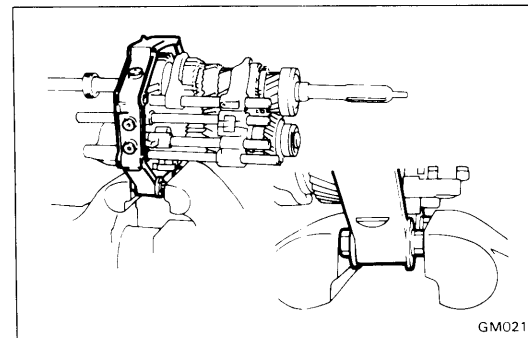

9. MOUNT INTERMEDIATE PLATE IN VISE

- (a) Use the two clutch housing bolts, plate washers and suitable nuts as shown.

CAUTION: Install the plate washers in reverse of normal position. Increase or decrease plate washers so that the bolt tip and front tip surface of the nut are aligned.

- (b) Mount the intermediate plate in a vise.

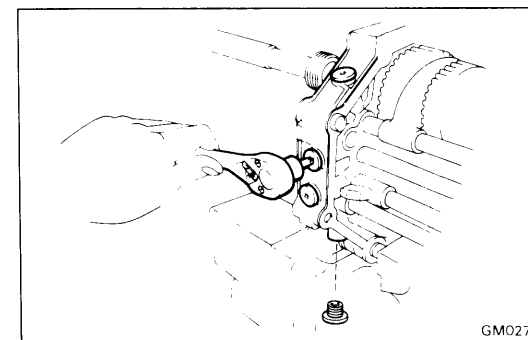

10. REMOVE STRAIGHT SCREW PLUGS, LOCKING BALLS AND SPRINGS

- (a) Using a torx socket wrench, remove the four plugs.

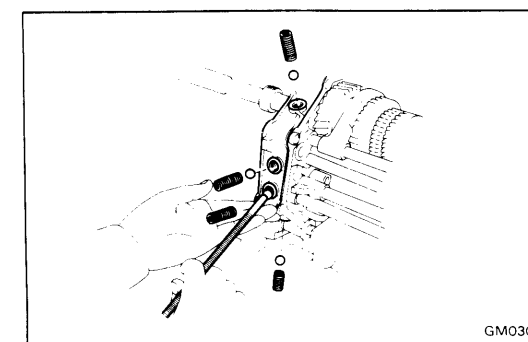

- (b) Using a magnetic finger, remove the springs and balls.

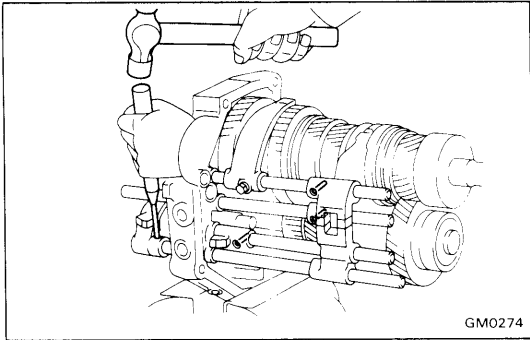

11. REMOVE SLOTTED SPRING PINS AND BOLT

- (a) Using a pin punch and hammer, drive out the four pins.

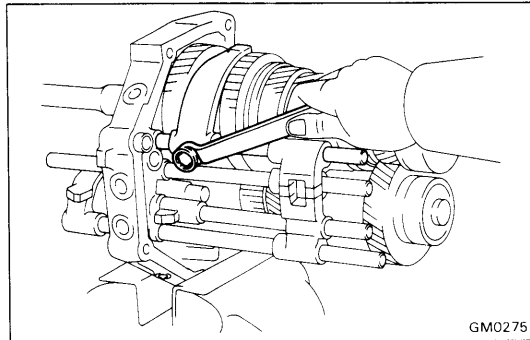

- (b) Remove the bolt from No. 1 shift fork.

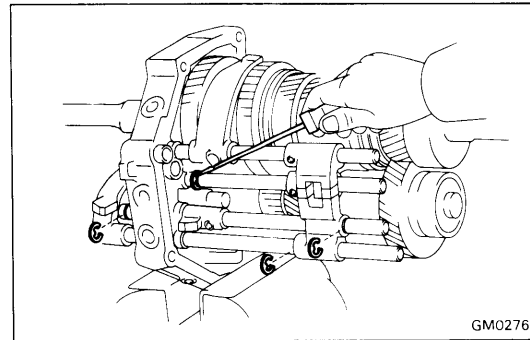

12. REMOVE E-RINGS

Using a screwdriver, remove the four E-rings.

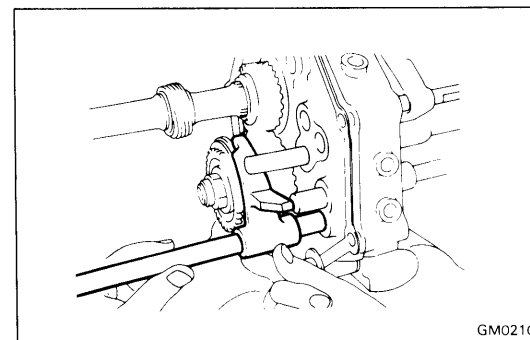

13. REMOVE NO. 4 SHIFT FORK SHAFT AND NO. 3 SHIFT FORK

- (a) Pull out No. 4 shift fork shaft from the intermediate plate.
- (b) Remove No. 3 shift fork.
- (c) Using a magnetic finger, remove the locking balls from the reverse shift head and intermediate plate.

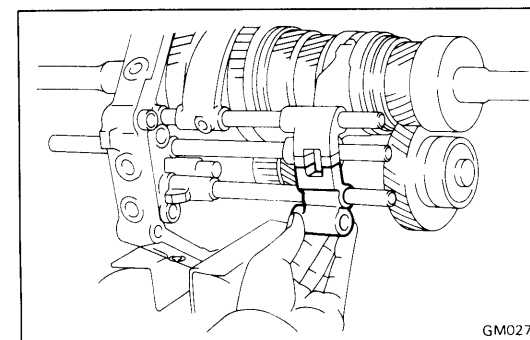

14. REMOVE REVERSE SHIFT HEAD

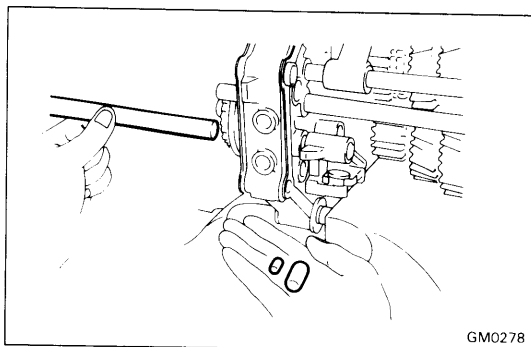
**15. REMOVE NO. 3 SHIFT FORK SHAFT**

- (a) Pull out No. 3 shift fork shaft from the intermediate plate.
- (b) Using a magnetic finger, remove the interlock pins from the shaft and intermediate plate.

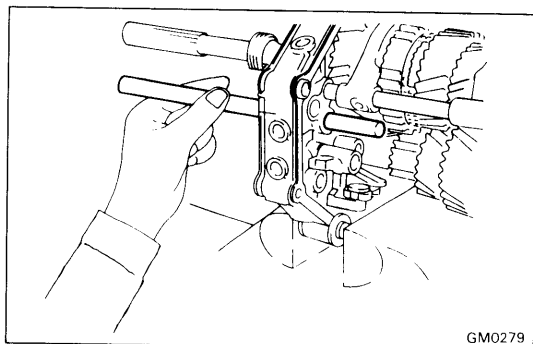
**16. REMOVE NO. 2 SHIFT FORK SHAFT**

- (a) Pull out No. 2 shift fork shaft from the intermediate plate.
- (b) Using a magnetic finger, remove the interlock pins from the shaft and intermediate plate.

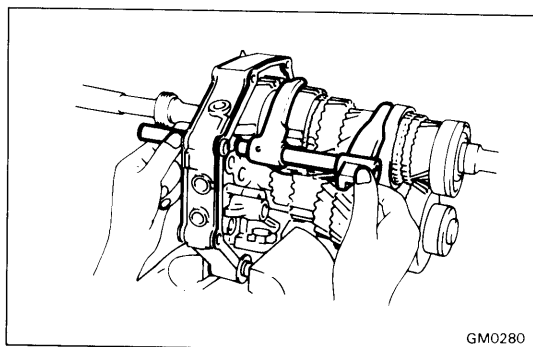
**17. REMOVE NO. 1 SHIFT FORK SHAFT, NO. 1 AND NO. 2 SHIFT FORKS AND FIRST AND SECOND SHIFT HEAD**

Pull out No. 1 shift fork shaft and remove No. 1 and No. 2 shift forks and 1st and 2nd shift head.

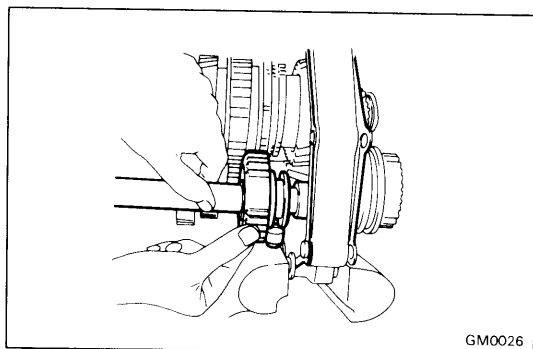
**18. REMOVE REVERSE IDLER GEAR AND SHAFT**

- (a) Remove the reverse idler gear shaft stopper.
- (b) Remove the reverse idler gear and shaft.

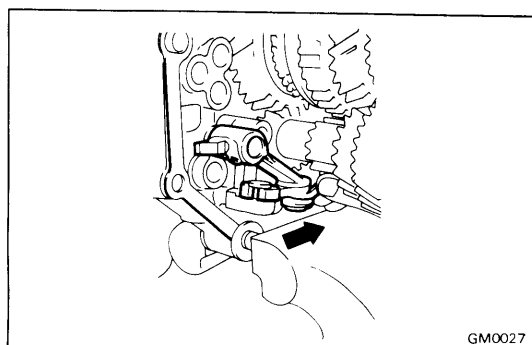
**19. REMOVE REVERSE SHIFT ARM FROM REVERSE SHIFT ARM BRACKET**

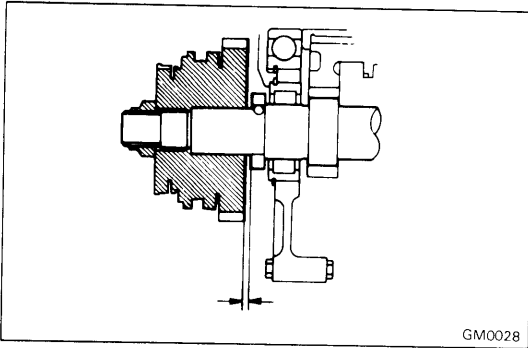

GM0028

20. MEASURE COUNTER FIFTH GEAR THRUST CLEARANCE

Using a feeler gauge, measure the counter 5th gear thrust clearance.

Standard clearance: 0.10 — 0.30 mm
(0.0039 — 0.0118 in.)

Maximum clearance: 0.30 mm (0.0118 in.)

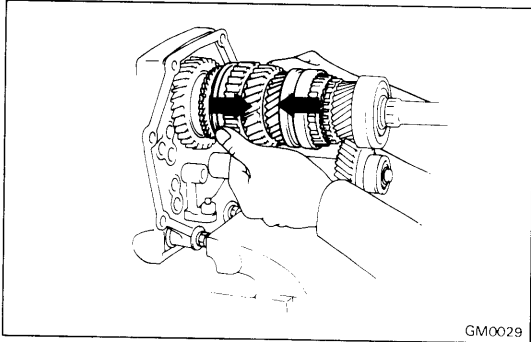

GM0029

21. REMOVE NO. 5 GEAR SPLINE PIECE, SYNCHRONIZER RING, NEEDLE ROLLER BEARINGS AND COUNTER FIFTH GEAR WITH NO. 3 HUB SLEEVE

- (a) Engage the gear double meshing.
- (b) Using a hammer and chisel, loosen the staked part of the nut.

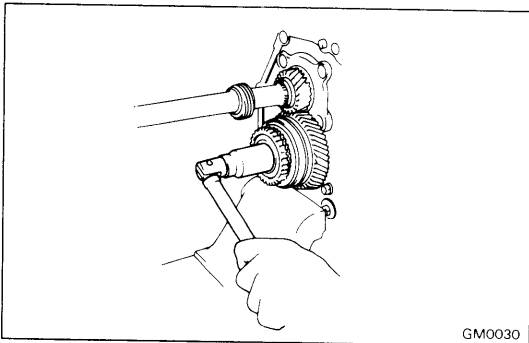

GM0030

- (c) Remove the lock nut.
- (d) Disengage the gear double meshing.

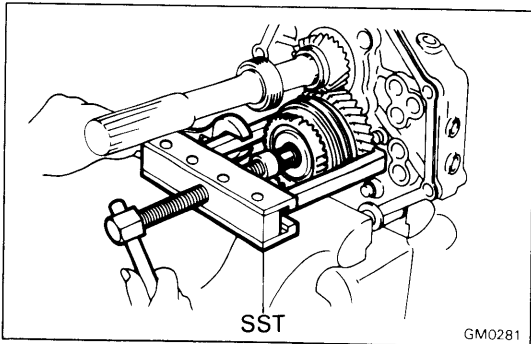

SST

GM0281

- (e) Using SST, remove No. 5 gear spline piece, synchronizer ring, needle roller bearings and counter 5th gear.

SST 09213-27010

22. REMOVE SPACER AND BALL

- (a) Remove the spacer.
- (b) Using a magnetic finger, remove the ball.

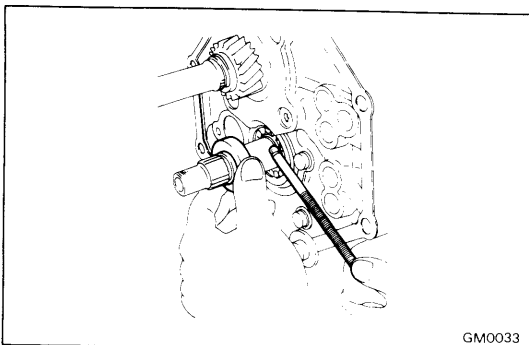

GM0033

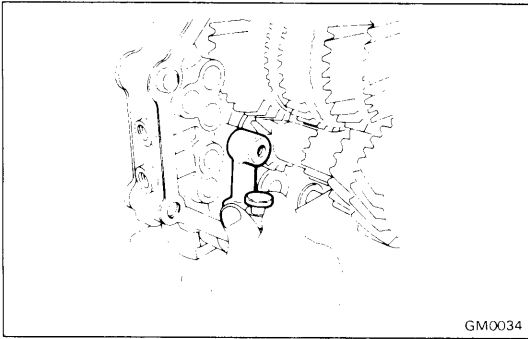

23. REMOVE REVERSE SHIFT ARM BRACKET

Remove the two bolts and reverse shift arm bracket.

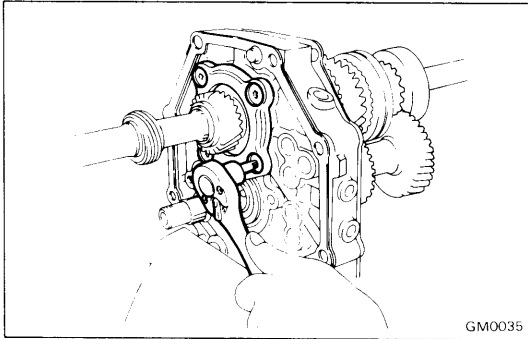

24. REMOVE REAR BEARING RETAINER

Using a torx socket wrench, remove the four screws.

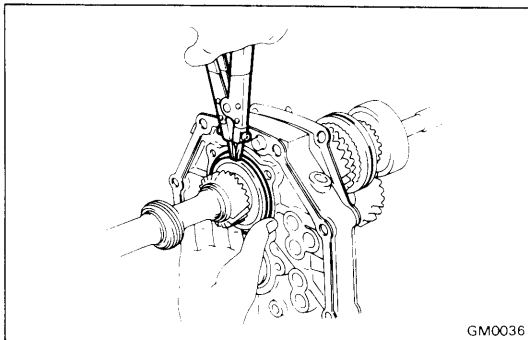

25. REMOVE BEARING SNAP RING

Using snap ring pliers, remove the snap ring.

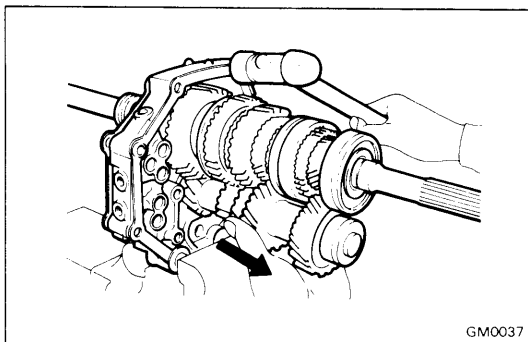

26. REMOVE OUTPUT SHAFT, COUNTER GEAR AND INPUT SHAFT AS A UNIT FROM INTERMEDIATE PLATE

- (a) Remove the output shaft, counter gear and input shaft as a unit from the intermediate plate by pulling on the counter gear and tapping on the intermediate plate with a plastic hammer.
- (b) Remove the input shaft with the 13 needle roller bearings from the output shaft.

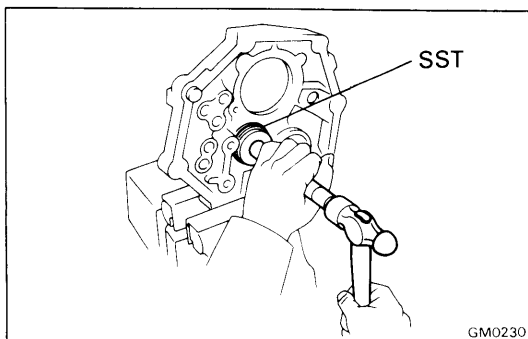

27. REMOVE COUNTER REAR BEARING FROM INTERMEDIATE PLATE

Using SST, remove the counter rear bearing.
 SST 09608-12010 (09608-00020, 09608-00050)

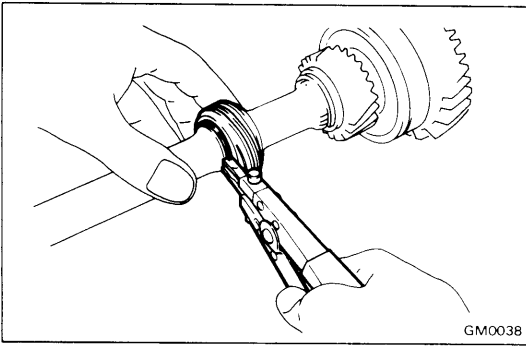

**28. (2WD)
REMOVE SPEEDOMETER DRIVE GEAR**

- (a) Using snap ring pliers, remove the rear snap ring.
- (b) Remove the speedometer drive gear.
- (c) Using a magnetic finger, remove the steel ball.
- (d) Using snap ring pliers, remove the front snap ring.

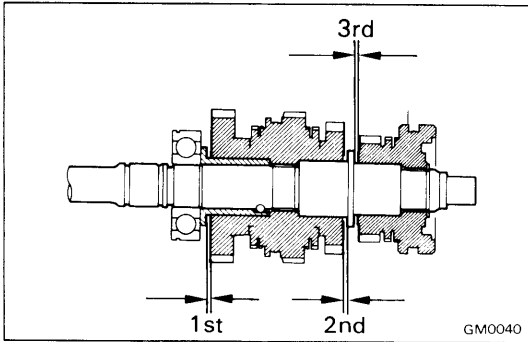

29. MEASURE EACH GEAR THRUST CLEARANCE

Measure the thrust clearance of each gear.

Standard clearance: 0.10 — 0.25 mm
(0.0039 — 0.0098 in.)

Maximum clearance: 0.25 mm (0.0098 in.)

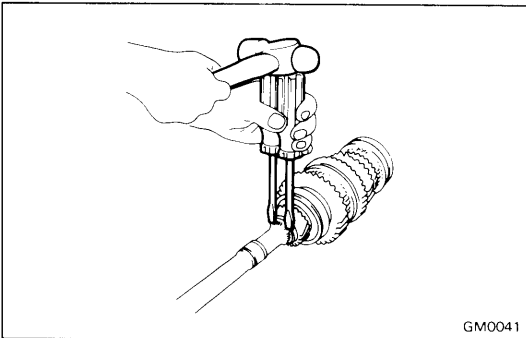

30. REMOVE FIFTH GEAR, REAR BEARING, FIRST GEAR, INNER RACE AND NEEDLE ROLLER BEARING

- (a) Using two screwdrivers and a hammer, tap out the snap ring.

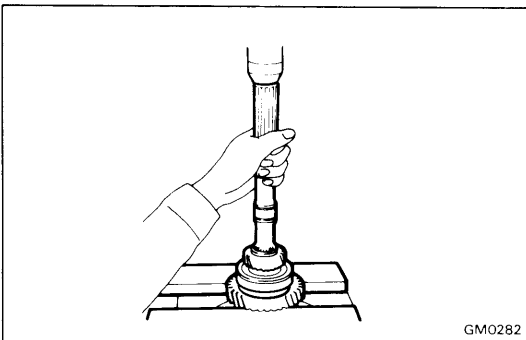

- (b) Using a press, remove the 5th gear, rear bearing, 1st gear and inner race.
- (c) Remove the needle roller bearing.
- (d) Remove the synchronizer ring.

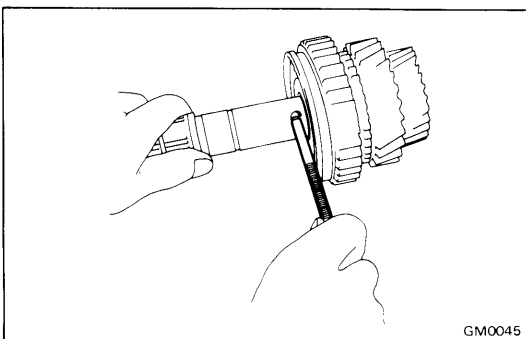

31. REMOVE LOCKING BALL

Using a magnetic finger, remove the locking ball.

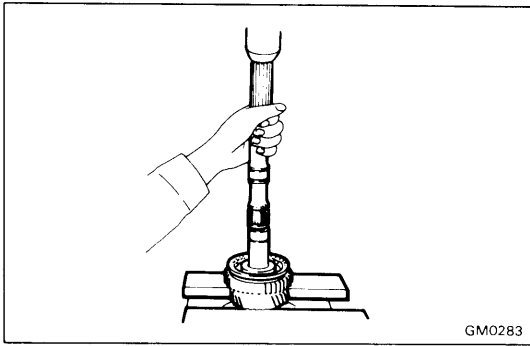

32. REMOVE NO. 1 HUB SLEEVE ASSEMBLY AND SECOND GEAR

- (a) Using a press, remove No. 1 hub sleeve, synchronizer ring and 2nd gear.
- (b) Remove the needle roller bearing.

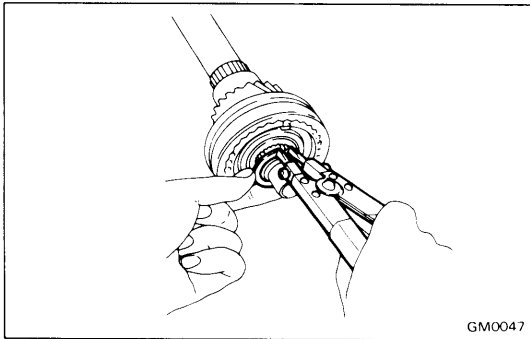

33. REMOVE NO. 2 HUB SLEEVE ASSEMBLY AND THIRD GEAR

- (a) Using snap ring pliers, remove the snap ring.

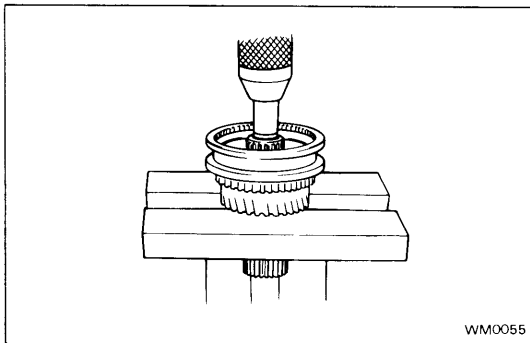

- (b) Using a press, remove No. 2 hub sleeve, synchronizer ring and 3rd gear.
- (c) Remove the needle roller bearing.

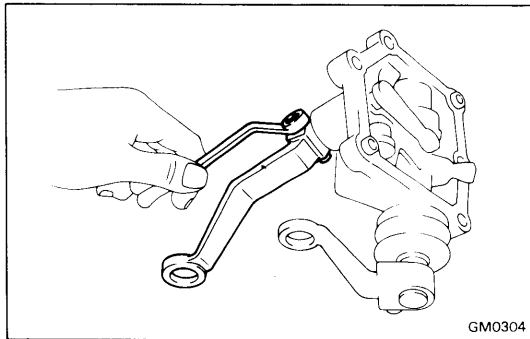

34. REMOVE SELECT OUTER LEVER AND LEVER SHAFT

- (a) Remove the lever lock pin and nut.
- (b) Remove the select outer lever, plate washer and lever shaft from the shift lever shaft housing.

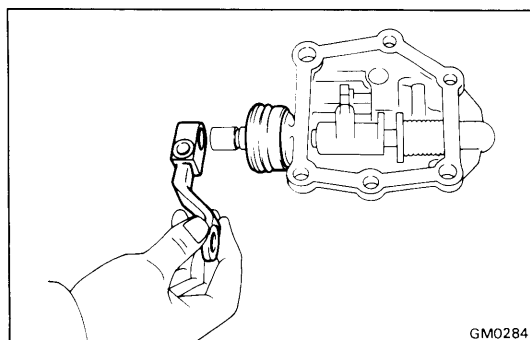

35. REMOVE SHIFT OUTER LEVER AND BOOT

Remove the lever lock pin and pull out the shift outer lever and boot.

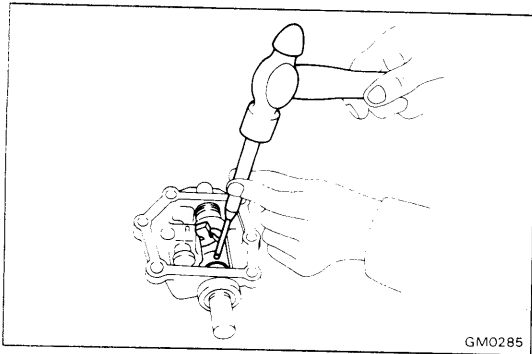

36. REMOVE SHIFT AND SELECT LEVER AND SHAFT

- (a) Using a pin punch and hammer, drive out the slotted spring pin.

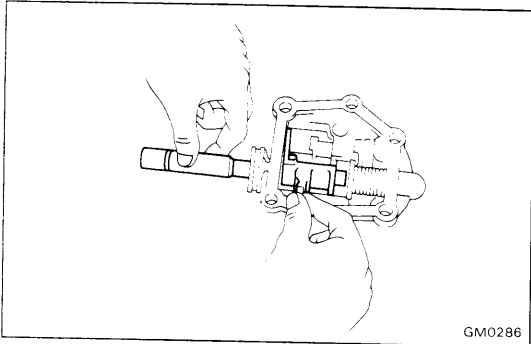

- (b) Remove the shift and select lever and shaft.

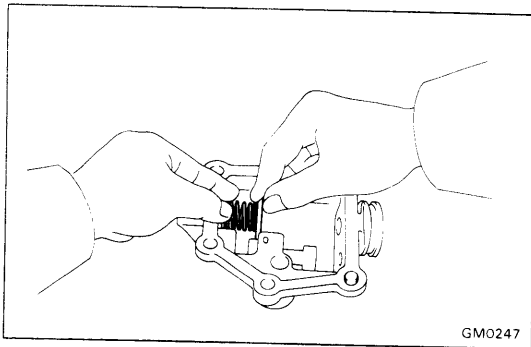

37. REMOVE SEAT AND COMPRESSION SPRING

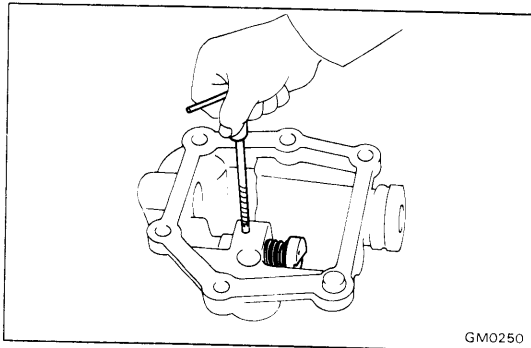

38. REMOVE REVERSE RESTRICT PIN AND COMPRESSION SPRING

- (a) Using a hammer, drive a screw extractor into the slotted spring pin. Pull out the slotted spring pin.

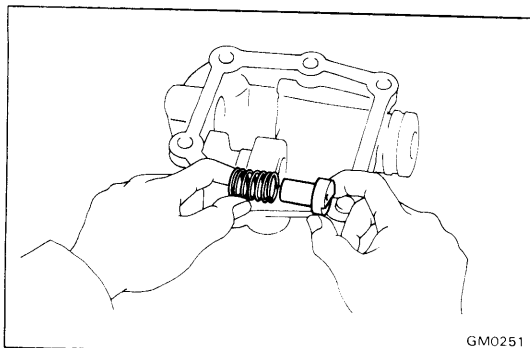

- (b) Remove the reverse restrict pin and compression spring.

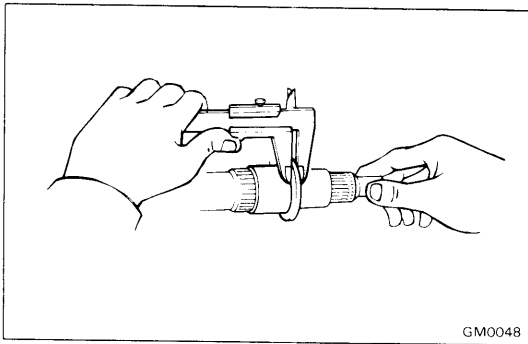

INSPECTION OF TRANSMISSION COMPONENTS

1. INSPECT OUTPUT SHAFT AND INNER RACE

- (a) Using calipers, measure the output shaft flange thickness.

Minimum thickness: 4.80 mm (0.1890 in.)

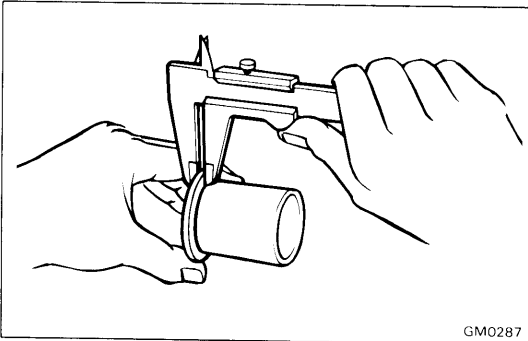

- (b) Using calipers, measure the inner race flange thickness.

Minimum thickness: 3.99 mm (0.1571 in.)

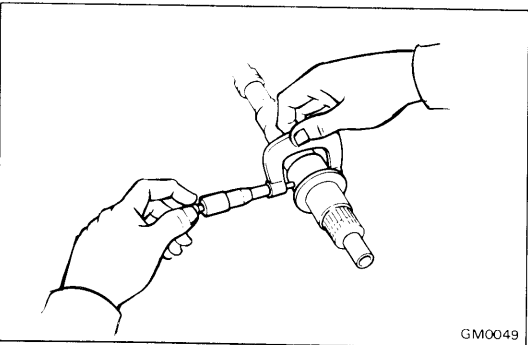

- (c) Using a micrometer, measure the outer diameter of the output shaft journal.

Minimum diameter:

2nd gear 37.984 mm (1.4954 in.)

3rd gear 34.984 mm (1.3773 in.)

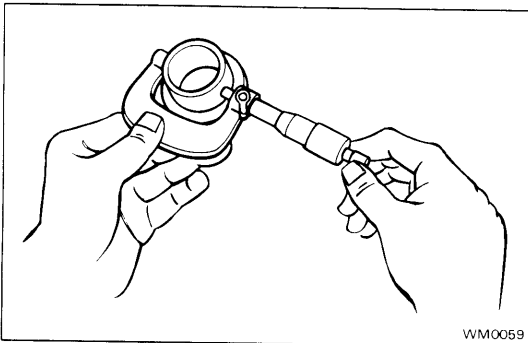

- (d) Using a micrometer, measure the outer diameter of the inner race.

Minimum diameter: 38.985 mm (1.5348 in.)

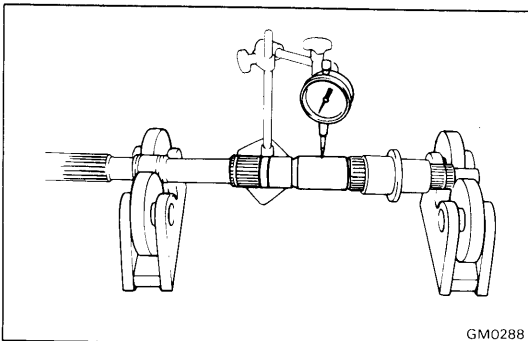

- (e) Using a dial indicator, check the shaft runout.

Maximum runout: 0.05 mm (0.0020 in.)

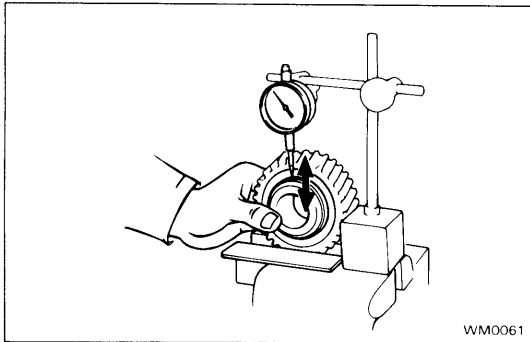

2. CHECK OIL CLEARANCE OF FIRST GEAR

Using a dial indicator, measure the oil clearance between the gear and inner race with the needle roller bearing installed.

Standard clearance: 0.009 — 0.032 mm
(0.0004 — 0.0013 in.)

Maximum clearance: 0.032 mm (0.0013 in.)

If the clearance exceeds the limit, replace the gear, inner race or needle roller bearing.

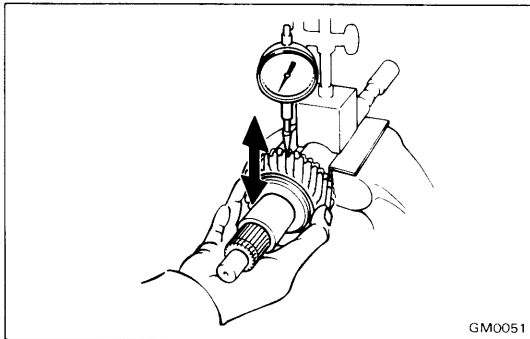

3. CHECK OIL CLEARANCE OF SECOND, THIRD AND COUNTER FIFTH GEARS

Using a dial indicator, measure the oil clearance between the gear and shaft with the needle roller bearing installed.

Standard clearance:

2nd and 3rd gears 0.009 — 0.033 mm
(0.0004 — 0.0013 in.)

Counter 5th gear 0.009 — 0.032 mm
(0.0004 — 0.0013 in.)

Maximum clearance:

2nd and 3rd gears 0.033 mm (0.0013 in.)

Counter 5th gear 0.032 mm (0.0013 in.)

If the clearance exceeds the limit, replace the gear, needle roller bearing or shaft.

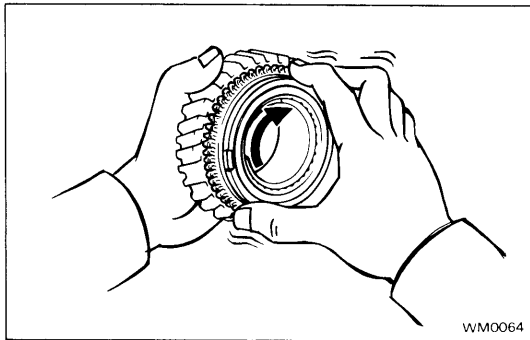

4. INSPECT SYNCHRONIZER RINGS

(a) Turn the ring and push it in to check the braking action.

(b) Measure the clearance between the synchronizer ring back and the gear spline end.

Standard clearance: 1.0 — 2.0 mm
(0.039 — 0.079 in.)

Minimum clearance: 0.8 mm (0.031 in.)

If the clearance is less than the limit, replace the synchronizer ring.

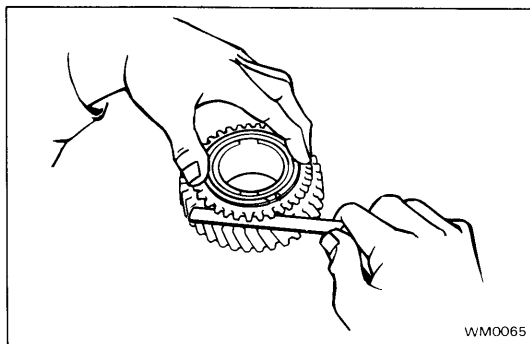

5. MEASURE CLEARANCE OF SHIFT FORKS AND HUB SLEEVES

Using a feeler gauge, measure the clearance between the hub sleeve and shift fork.

Maximum clearance: 1.0 mm (0.039 in.)

If the clearance exceeds the limit, replace the shift fork or hub sleeve.

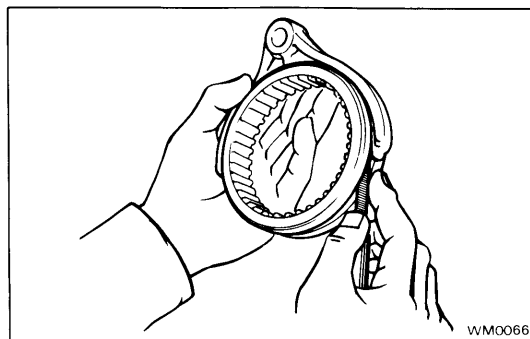

6. IF NECESSARY, REPLACE INPUT SHAFT BEARING

(a) Using snap ring pliers, remove the snap ring.

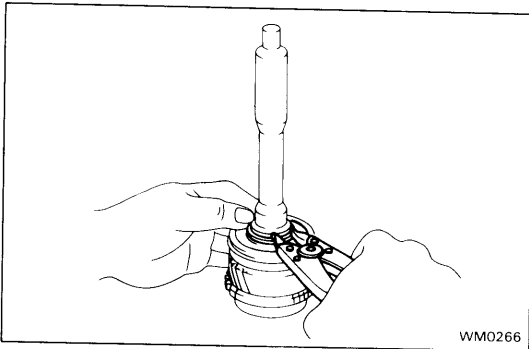

(b) Using a press, remove the bearing.

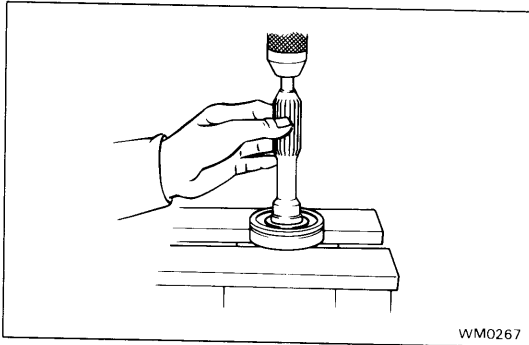

(c) Using SST and a press, install a new bearing.
SST 09506-35010

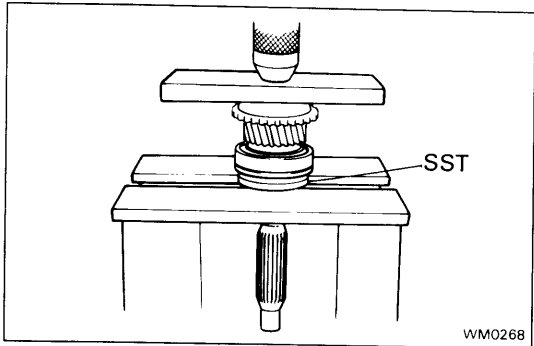

(d) Select a snap ring that will allow minimum axial play and install it on the shaft.

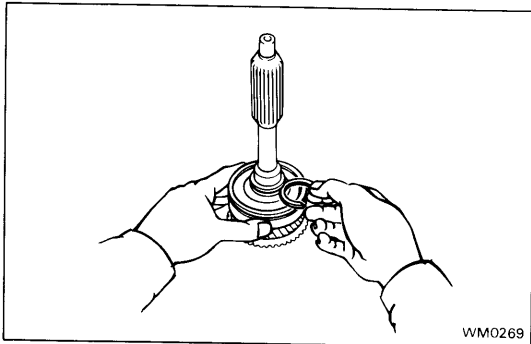

Mark	Thickness	mm (in.)
0	2.05 — 2.10	(0.0807 — 0.0827)
1	2.10 — 2.15	(0.0827 — 0.0846)
2	2.15 — 2.20	(0.0846 — 0.0866)
3	2.20 — 2.25	(0.0866 — 0.0886)
4	2.25 — 2.30	(0.0886 — 0.0906)
5	2.30 — 2.35	(0.0906 — 0.0925)

7. IF NECESSARY, REPLACE FRONT BEARING RETAINER OIL SEAL

(a) Using a screwdriver, pry out the oil seal.

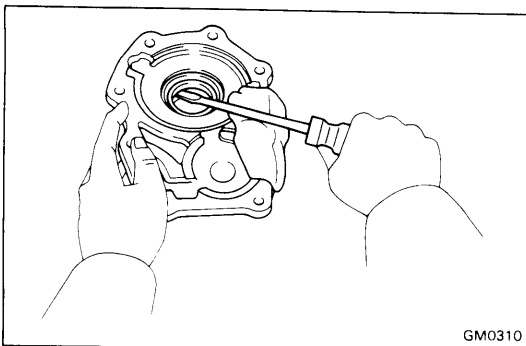

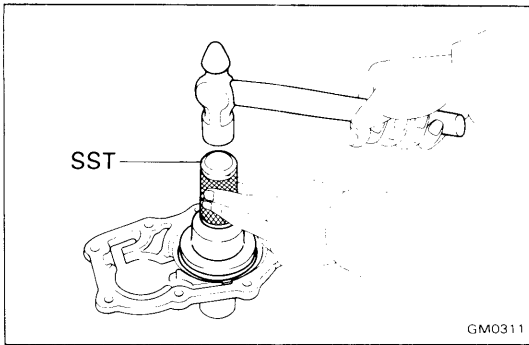

(b) Using SST, drive in a new oil seal.

SST 09223-50010

Drive in depth: **12.2 — 13.2 mm (0.480 — 0.520 in.)**
Transmission case installation surface

(c) Coat the lip of the oil seal with MP grease.

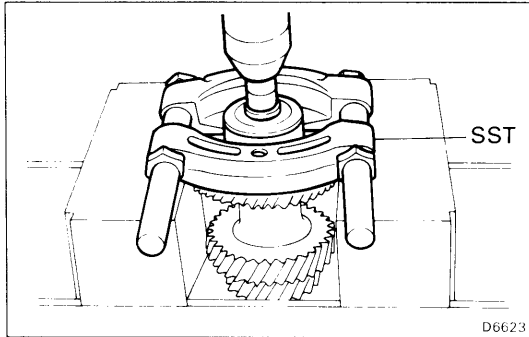

8. IF NECESSARY, REPLACE COUNTER GEAR FRONT BEARING

(a) Using snap ring pliers, remove the snap ring.

(b) Using SST and a socket wrench, press out the bearing.

SST 09950-00020

(c) Replace the side race.

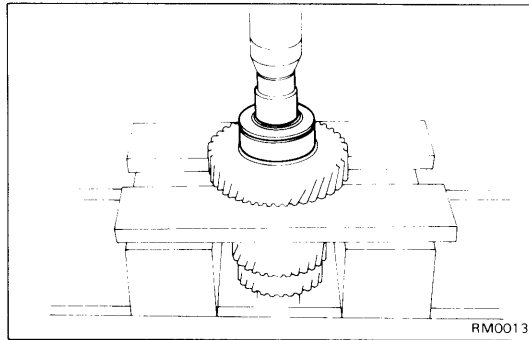

(d) Using a socket wrench, press in the bearing and inner race.

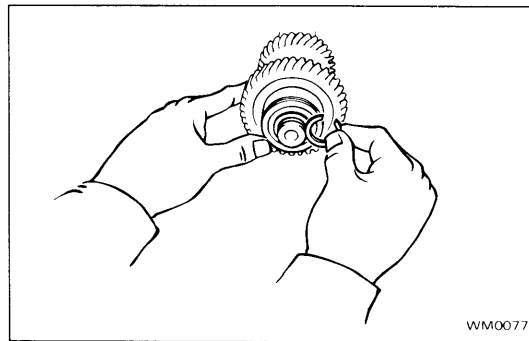

(e) Select a snap ring that will allow minimum axial play and install it on the shaft.

Mark	Thickness	mm (in.)
1	2.05 — 2.10	(0.0807 — 0.0827)
2	2.10 — 2.15	(0.0827 — 0.0846)
3	2.15 — 2.20	(0.0846 — 0.0866)
4	2.20 — 2.25	(0.0866 — 0.0886)
5	2.25 — 2.30	(0.0886 — 0.0906)
6	2.30 — 2.35	(0.0906 — 0.0925)

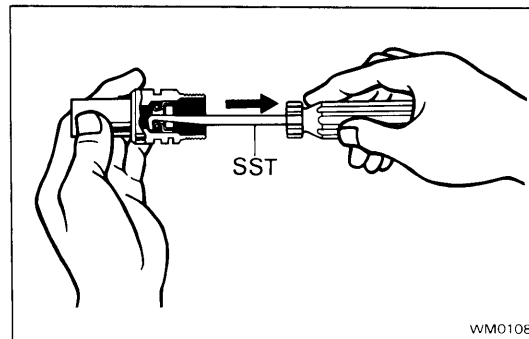

9. (2WD) IF NECESSARY, REPLACE SPEEDOMETER DRIVEN GEAR OIL SEAL

(a) Using SST, pull out the oil seal.

SST 09921-00010

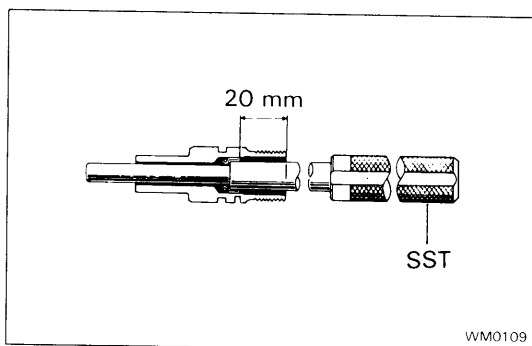

(b) Using SST, drive in a new oil seal into the sleeve.

SST 09201-60011

Drive in depth: 20 mm (0.79 in.)

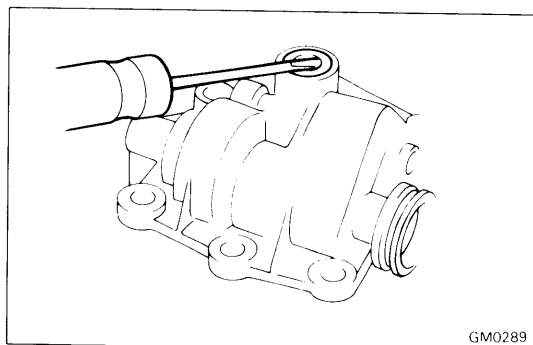

10. IF NECESSARY, REPLACE SELECT OUTER LEVER OIL SEAL

(a) Using a screwdriver, pry out the oil seal.

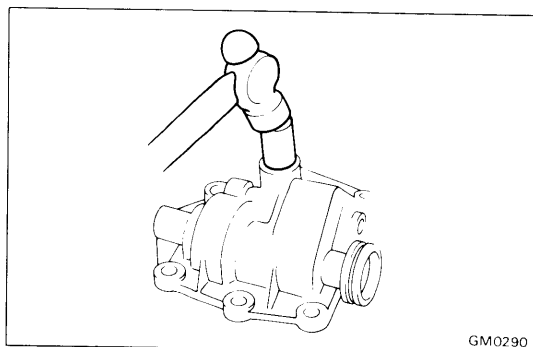

(b) Using a socket wrench and hammer, drive in a new oil seal.

(c) Coat the lip of the oil seal with MP grease.

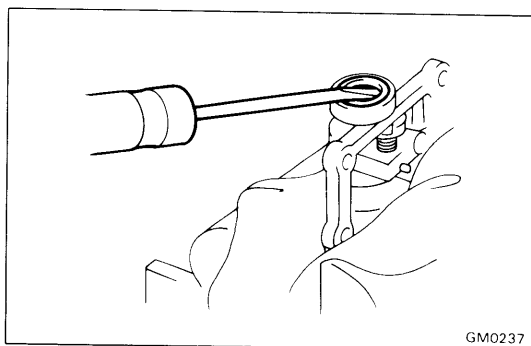

11. IF NECESSARY, REPLACE SHIFT OUTER LEVER OIL SEAL

(a) Using a screwdriver, pry out the oil seal.

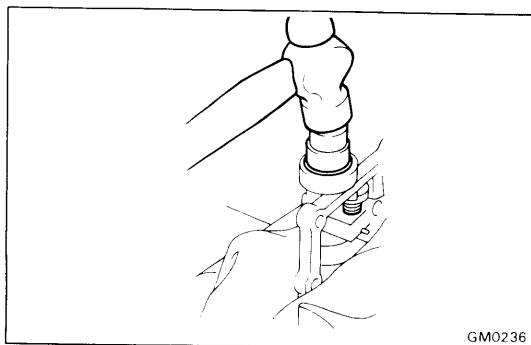

(b) Using a socket wrench and hammer, drive in a new oil seal.

(c) Coat the lip of the oil seal with MP grease.

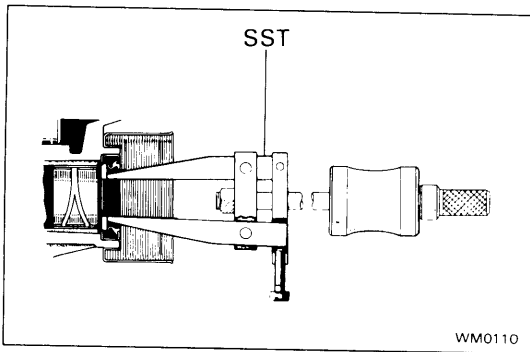

**12. (2WD)
IF NECESSARY, REPLACE EXTENSION HOUSING OIL
SEAL AND BUSHING**

(a) Using SST, remove the oil seal.

SST 09308-00010 or
09308-10010 with output shaft installed

(b) Heat the extension housing end to 80 — 100°C (176
— 212°F) in an oil bath.

(c) Using SST, remove the bushing and install a new
bushing.

SST 09307-30010

(d) Using SST, drive in a new oil seal.

SST 09325-20010

(e) Coat the lip of the oil seal with MP grease.

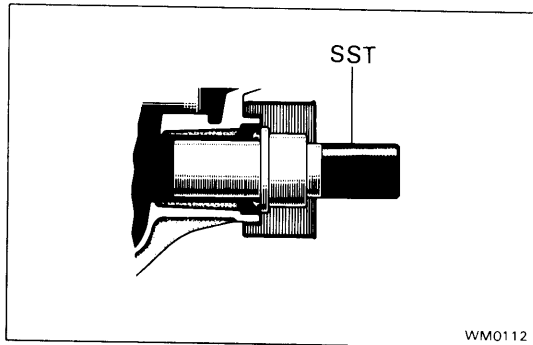
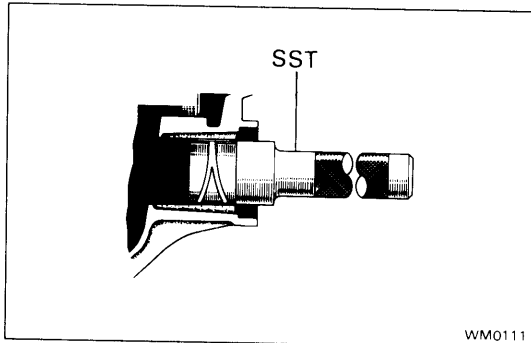

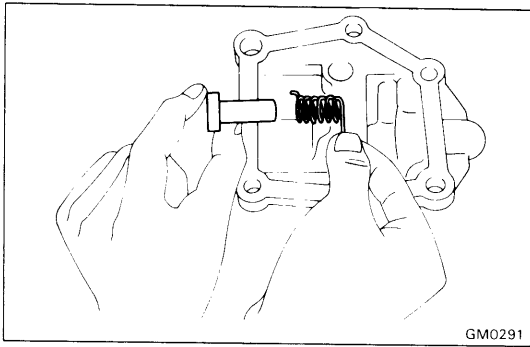

GM0291

ASSEMBLY OF TRANSMISSION

(See pages MT-6,7)

1. INSTALL REVERSE RESTRICT PIN AND COMPRESSION SPRING

- (a) Install the reverse restrict pin and compression spring.

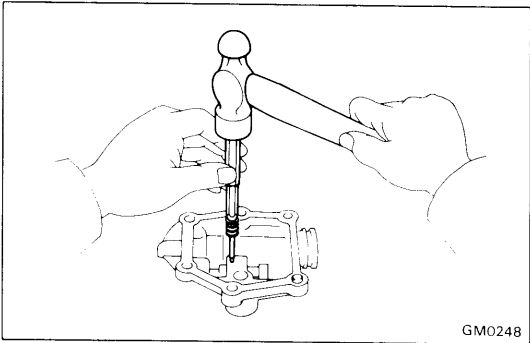

GM0248

- (b) Using a pin punch and hammer, drive in the slotted spring pin.

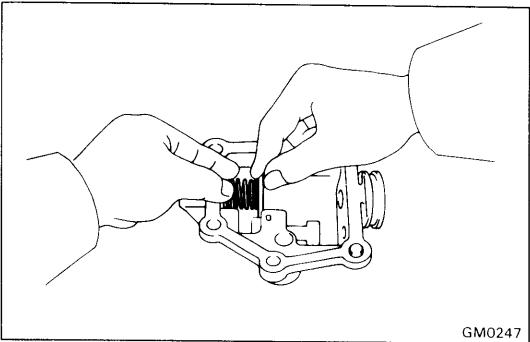

GM0247

2. INSTALL SEAT AND COMPRESSION SPRING

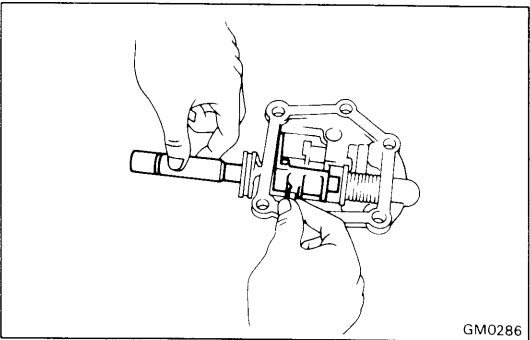

GM0286

3. INSTALL SHIFT AND SELECT LEVER AND SHAFT

- (a) Install the shift and select lever and shaft to the shift lever shaft housing.

NOTE: One of the spline teeth of the shaft has been eliminated. Therefore, be certain to correctly align this portion to the matching portion on the lever during assembly.

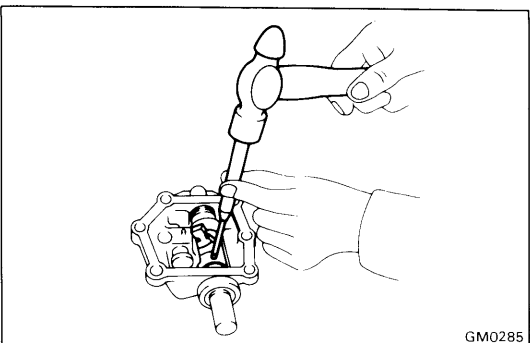

GM0285

- (b) Using a pin punch and hammer, drive in the slotted spring pin.

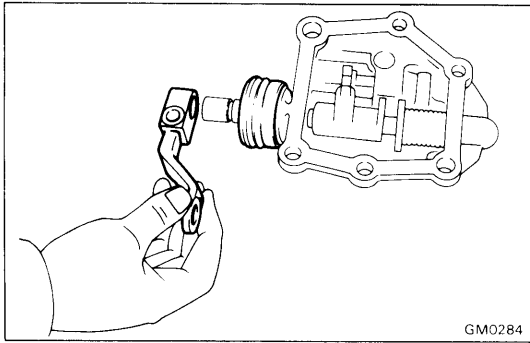

4. INSTALL SHIFT OUTER LEVER AND BOOT

Install the shift outer lever and boot to the shaft with the lever lock pin and nut. Torque the nut.

Torque: 120 kg-cm (9 ft-lb, 12 N·m)

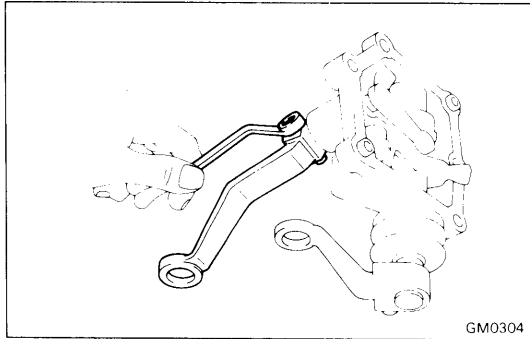

5. INSTALL SELECT OUTER LEVER AND LEVER SHAFT

Install the select outer lever, plate washer and lever shaft with the lever lock pin and nut. Torque the nut.

Torque: 80 kg-cm (69 in.-lb, 7.8 N·m)

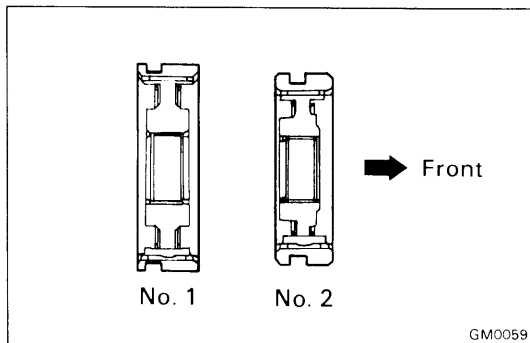

6. INSERT NO. 1 AND NO. 2 CLUTCH HUBS INTO HUB SLEEVES

(a) Install the clutch hub and shifting keys to the hub sleeve.

(b) Install the shifting key springs under the shifting keys.

CAUTION: Install the key springs positioned so that their end gaps are not in line.

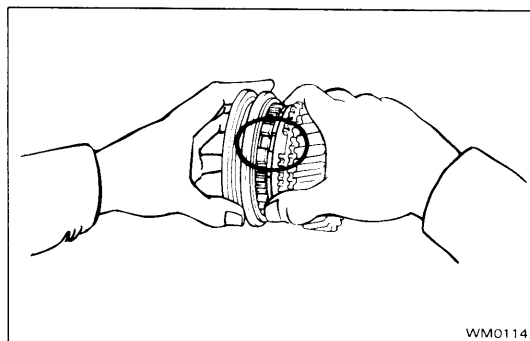

7. INSTALL THIRD GEAR AND NO. 2 HUB SLEEVE ASSEMBLY ON OUTPUT SHAFT

(a) Apply gear oil to the shaft and needle roller bearing.

(b) Place the synchronizer ring on the gear and align the ring slots with the shifting keys.

(c) Install the needle roller bearing in the 3rd gear.

(d) Using SST and a press, install the 3rd gear and No. 2 hub sleeve.

SST 09506-35010

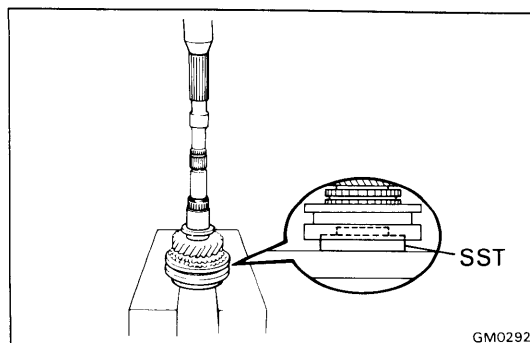

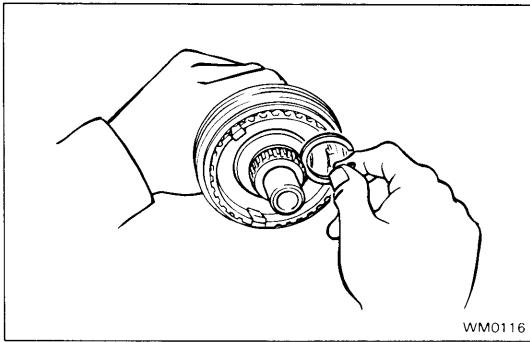

8. INSTALL SNAP RING

(a) Select a snap ring that will allow minimum axial play.

Mark	Thickness	mm (in.)
C-1	1.75 — 1.80	(0.0689 — 0.0709)
D	1.80 — 1.85	(0.0709 — 0.0728)
D-1	1.85 — 1.90	(0.0728 — 0.0748)
E	1.90 — 1.95	(0.0748 — 0.0768)
E-1	1.95 — 2.00	(0.0768 — 0.0787)
F	2.00 — 2.05	(0.0787 — 0.0807)
F-1	2.05 — 2.10	(0.0807 — 0.0827)

(b) Using snap ring pliers, install the snap ring.

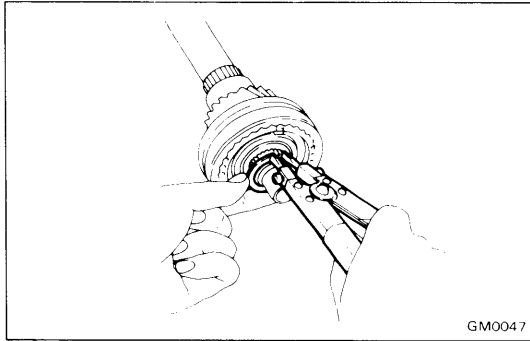

9. MEASURE THIRD GEAR THRUST CLEARANCE

Using a feeler gauge, measure the 3rd gear thrust clearance.

Standard clearance: 0.10 — 0.25 mm
(0.0039 — 0.0098 in.)

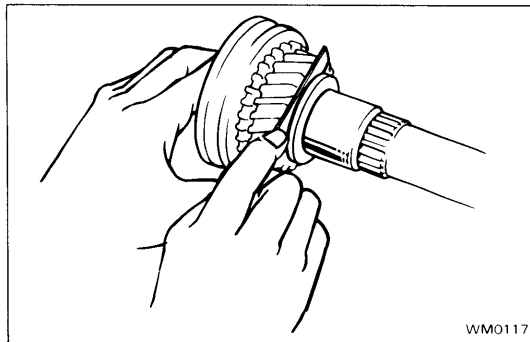

10. INSTALL SECOND GEAR AND NO. 1 HUB SLEEVE ASSEMBLY

- (a) Apply gear oil to the shaft and needle roller bearing.
- (b) Place the synchronizer ring on the gear and align the ring slots with the shifting keys.
- (c) Install the needle roller bearing in the 2nd gear.

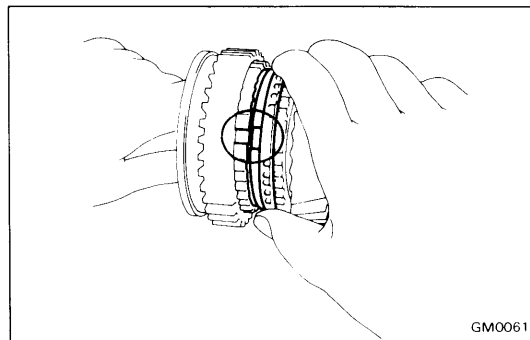

(d) Using SST and a press, install the 2nd gear and No. 1 hub sleeve.

SST 09316-60010 (09316-00020)

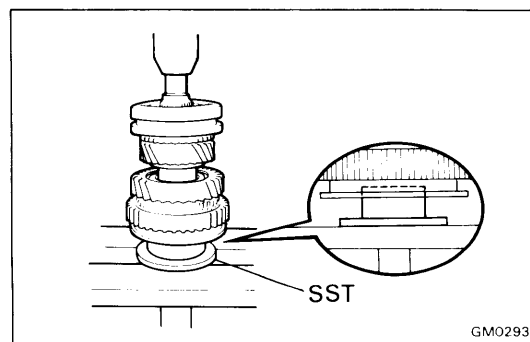

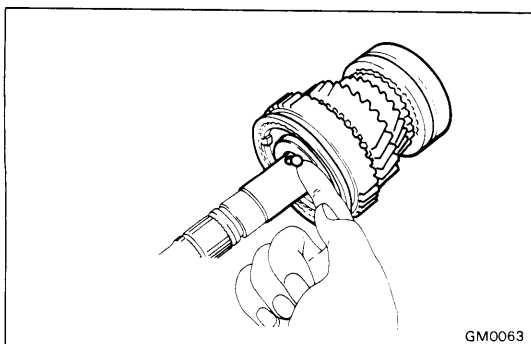

11. INSTALL LOCKING BALL AND FIRST GEAR ASSEMBLY

- (a) Install the locking ball in the shaft.
- (b) Apply gear oil to the needle roller bearing.
- (c) Assemble the 1st gear, synchronizer ring, needle roller bearing and bearing inner race.

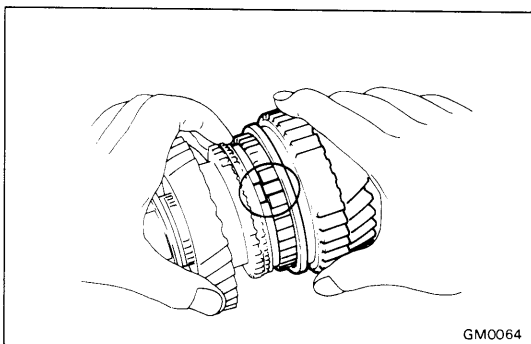

- (d) Install the assembly on the output shaft with the synchronizer ring slots aligned with the shifting keys.
- (e) Turn the inner race to align it with the locking ball.

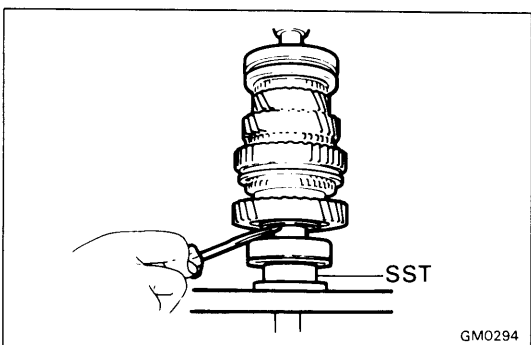

12. INSTALL OUTPUT SHAFT REAR BEARING

Using SST and a press, install the bearing on the output shaft with the outer race snap ring groove toward the rear.

NOTE: Hold the 1st gear inner race with a screwdriver to prevent it from falling.

SST 09316-60010 (09316-00020)

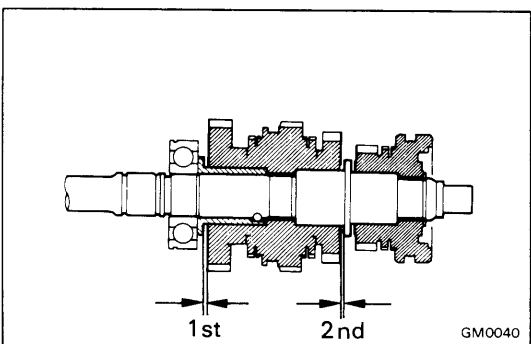

13. MEASURE FIRST AND SECOND GEAR THRUST CLEARANCE

Using a feeler gauge, measure the 1st and 2nd gear thrust clearance.

Standard clearance: 0.10 — 0.25 mm
(0.0039 — 0.0098 in.)

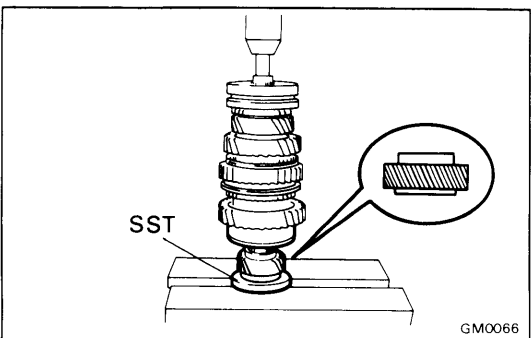

14. INSTALL FIFTH GEAR

Using SST and a press, install the 5th gear.

SST 09506-35010

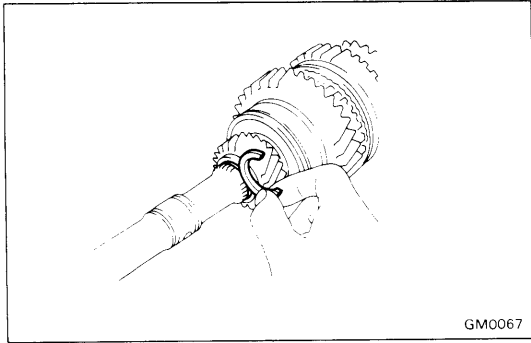

15. INSTALL SNAP RING

(a) Select a snap ring that will allow minimum axial play.

Mark	Thickness mm (in.)	Mark	Thickness mm (in.)
A	2.67 — 2.72 (0.1051 — 0.1071)	G	3.03 — 3.08 (0.1193 — 0.1213)
B	2.73 — 2.78 (0.1075 — 0.1094)	H	3.09 — 3.14 (0.1217 — 0.1236)
C	2.79 — 2.84 (0.1098 — 0.1118)	J	3.15 — 3.20 (0.1240 — 0.1260)
D	2.85 — 2.90 (0.1122 — 0.1142)	K	3.21 — 3.26 (0.1264 — 0.1283)
E	2.91 — 2.96 (0.1146 — 0.1165)	L	3.27 — 3.32 (0.1287 — 0.1307)
F	2.97 — 3.02 (0.1169 — 0.1189)		

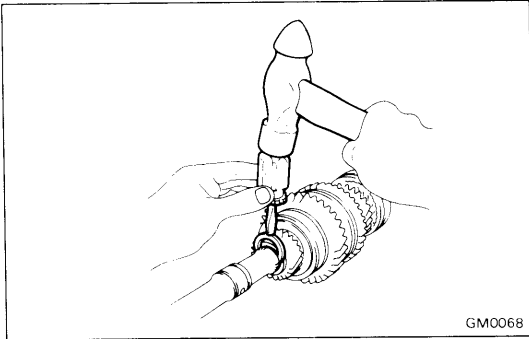

(b) Using a screwdriver and hammer, install the snap ring.

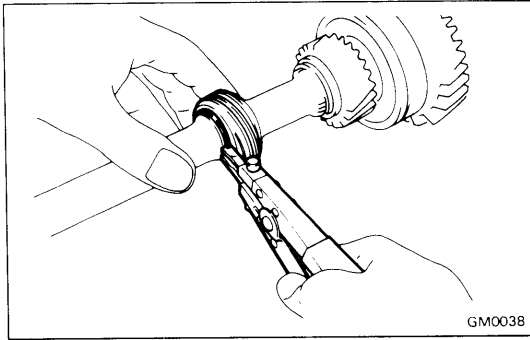

16. (2WD) INSTALL SPEEDOMETER DRIVE GEAR

- (a) Using snap ring pliers, install the front snap ring.
- (b) Install the ball and drive gear.
- (c) Using snap ring pliers, install the rear snap ring.

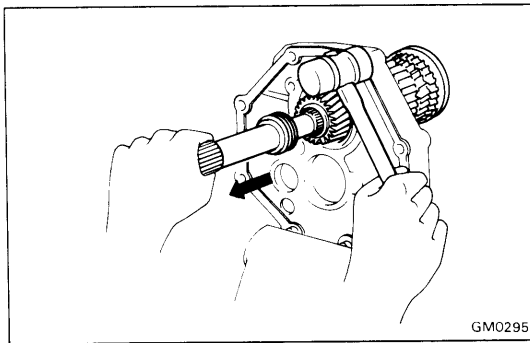

17. INSTALL OUTPUT SHAFT TO INTERMEDIATE PLATE

Install the output shaft into the intermediate plate by pulling on the output shaft and tapping on the intermediate plate.

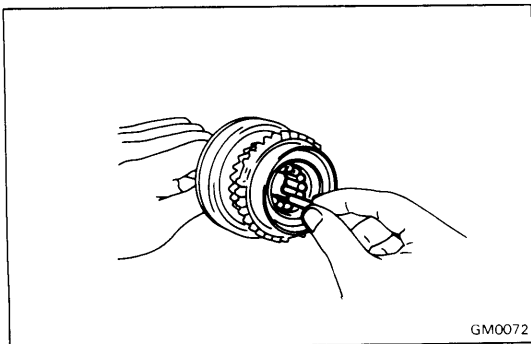

18. INSTALL INPUT SHAFT

(a) Apply MP grease to the 13 needle roller bearings and install them into the input shaft.

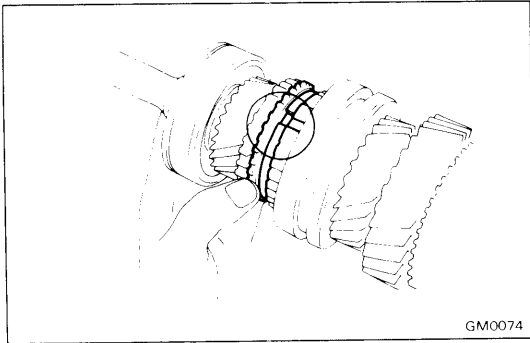

- (b) Install the input shaft to the output shaft with the synchronizer ring slots aligned with the shifting keys.

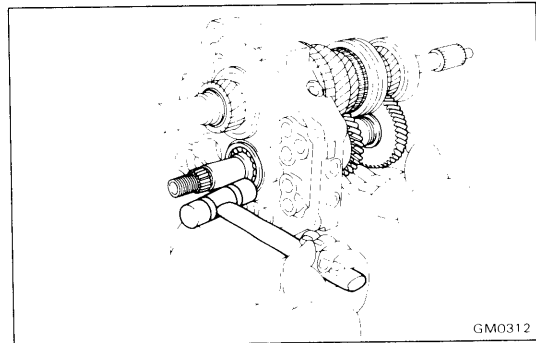

19. INSTALL COUNTER GEAR

Install the counter gear into the intermediate plate while holding the counter gear, and install the counter rear bearing with a plastic hammer.

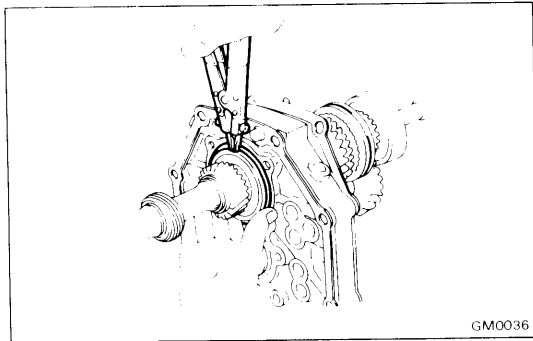

20. INSTALL BEARING SNAP RING

Using snap ring pliers, install the snap ring.

NOTE: Be sure the snap ring is flush with the intermediate plate surface.

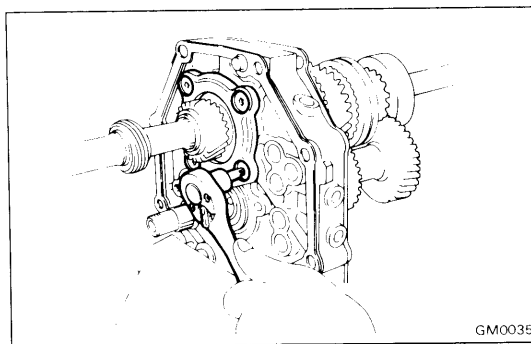

21. INSTALL REAR BEARING RETAINER

Using a torx socket wrench, install and torque the screws.

Torque: 185 kg-cm (13 ft-lb, 18 N·m)

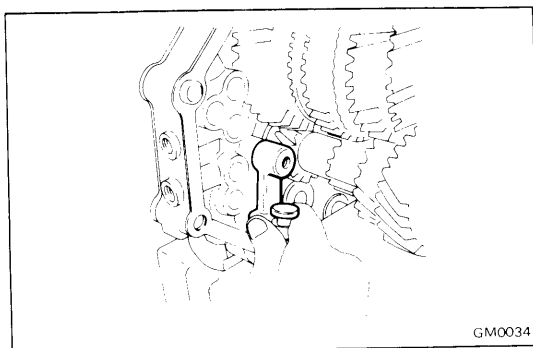

22. INSTALL REVERSE SHIFT ARM BRACKET

Install the reverse shift arm bracket and torque the bolts.

Torque: 185 kg-cm (13 ft-lb, 18 N·m)

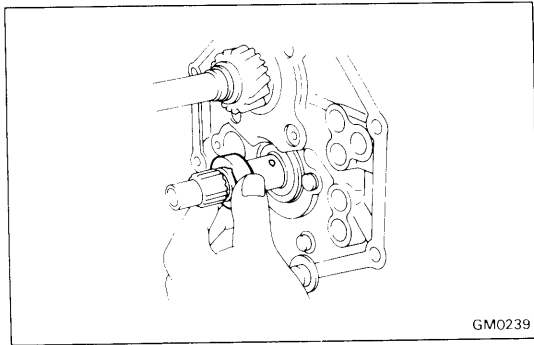

23. INSTALL BALL AND SPACER

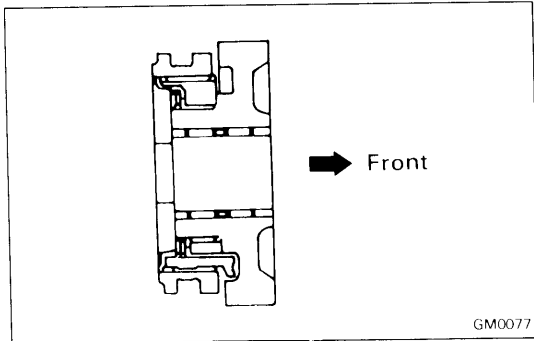

24. INSERT COUNTER FIFTH GEAR INTO NO. 3 HUB SLEEVE

- (a) Install the shifting keys and No. 3 hub sleeve onto the counter 5th gear.
- (b) Install the shifting key springs under the shifting keys.

CAUTION: Install the key springs positioned so that their end gaps are not in line.

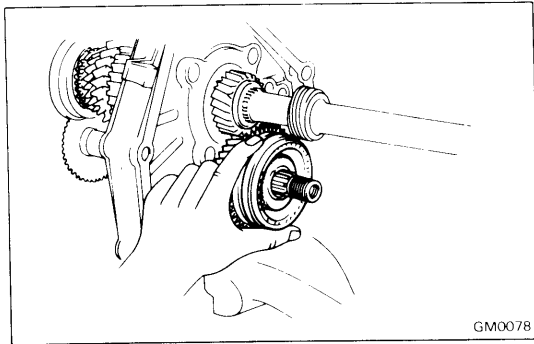

25. INSTALL COUNTER FIFTH GEAR WITH NO. 3 HUB SLEEVE ASSEMBLY AND NEEDLE ROLLER BEARINGS

- (a) Apply gear oil to the needle roller bearings.
- (b) Install the counter 5th gear with No. 3 hub sleeve and needle roller bearings.

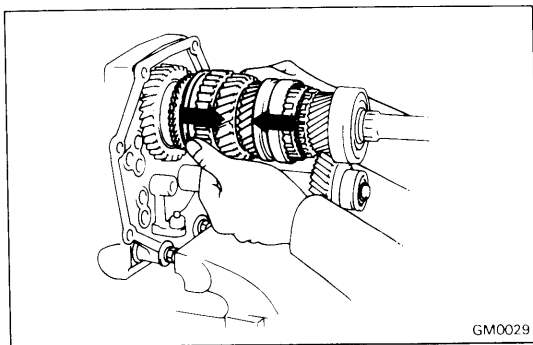

26. INSTALL SYNCHRONIZER RING, NO. 5 GEAR SPLINE PIECE AND LOCK NUT

- (a) Engage the gear double meshing.
- (b) Install the synchronizer ring onto No. 5 gear spline piece.

- (c) Align the synchronizer ring slots with the shifting keys. Install a new lock nut on the end of the counter gear and press fit the gear spline piece to the counter gear.

Torque: 1,200 kg-cm (87 ft-lb, 118 N·m)

- (d) Stake the lock nut.

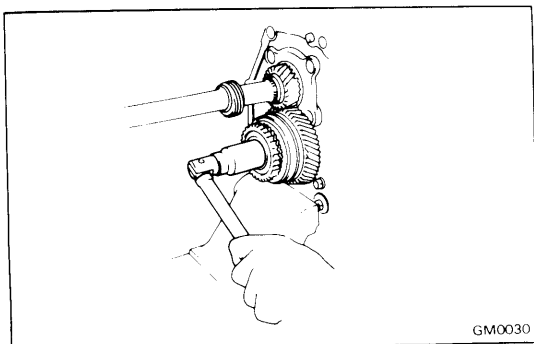

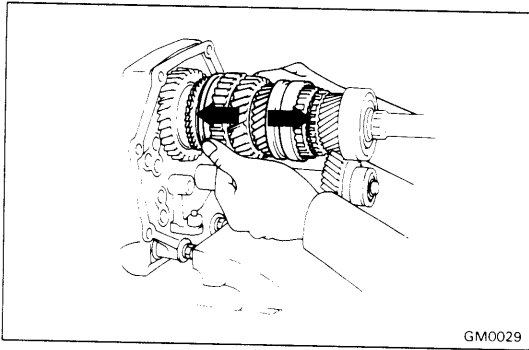

- (e) Disengage the gear double meshing.

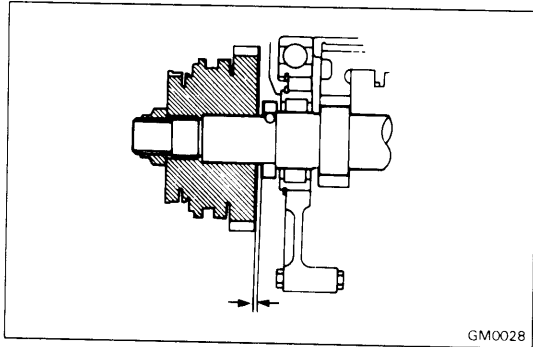

27. MEASURE COUNTER FIFTH GEAR THRUST CLEARANCE

Using a feeler gauge, measure the counter 5th gear thrust clearance.

Standard clearance: 0.10 — 0.30 mm
(0.0039 — 0.0118 in.)

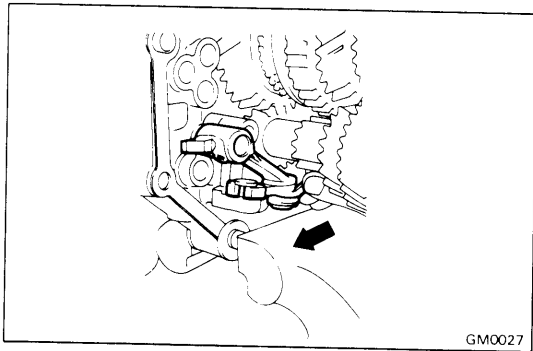

28. INSTALL REVERSE SHIFT ARM TO REVERSE SHIFT ARM BRACKET

Install the reverse shift arm to the pivot of the reverse shift arm bracket.

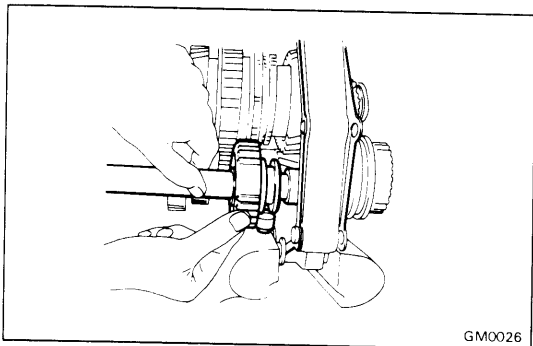

29. INSTALL REVERSE IDLER GEAR AND SHAFT

- Install the reverse idler gear on the shaft.
- Align the reverse shift arm shoe to the reverse idler gear groove and insert the reverse idler gear shaft to the intermediate plate.
- Install the reverse idler gear shaft stopper and torque the bolt.

Torque: 175 kg-cm (13 ft-lb, 17 N·m)

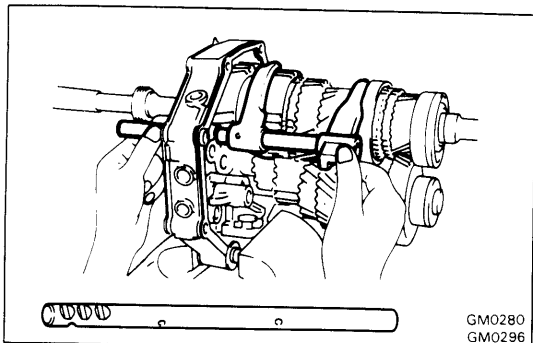

30. INSTALL NO. 1 SHIFT FORK SHAFT, NO. 1 AND NO. 2 SHIFT FORKS AND FIRST AND SECOND SHIFT HEAD

Place No. 1 and No. 2 shift forks into the groove of No. 1 and No. 2 hub sleeves, and install No. 1 fork shaft to No. 1 fork and the 1st and 2nd shift head through the intermediate plate.

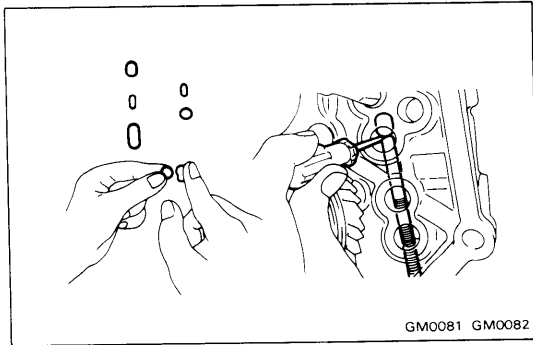

31. INSTALL NO. 2 SHIFT FORK SHAFT

- (a) Apply MP grease to the interlock pins.
- (b) Using a magnetic finger and screwdriver, install the interlock pin into the intermediate plate.

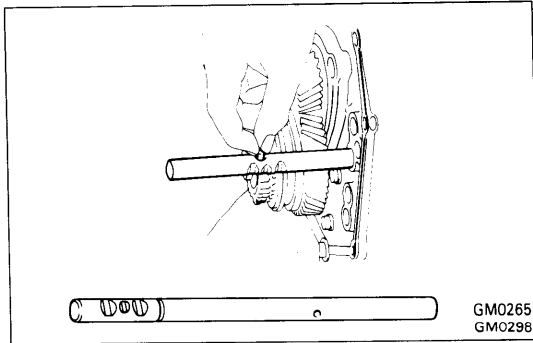

- (c) Install the interlock pin into the shaft hole.

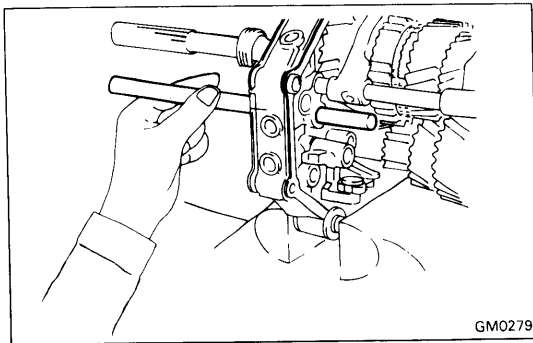

- (d) Install No. 2 fork shaft to No. 2 shift fork through the intermediate plate.

32. INSTALL NO. 3 SHIFT FORK SHAFT

- (a) Using a magnetic finger and screwdriver, install the interlock pin into the intermediate plate.

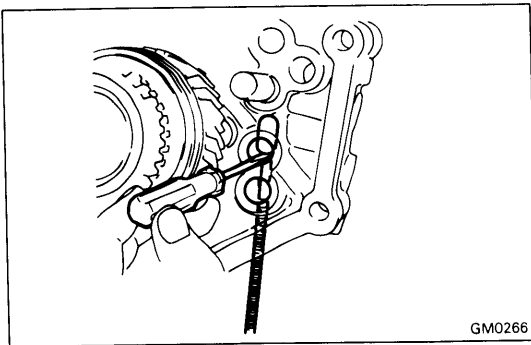

- (b) Install the interlock pin into the shaft hole.

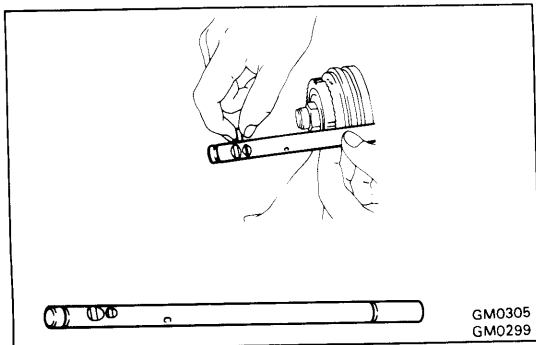

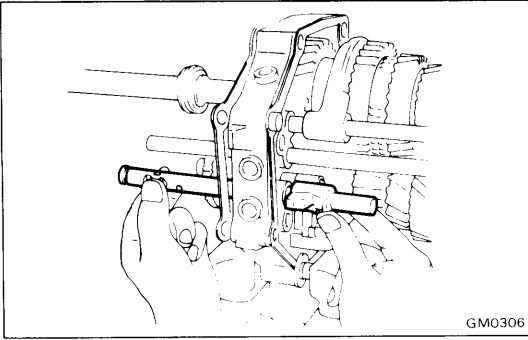

- (c) Install No. 3 fork shaft to the reverse shift arm through the intermediate plate.

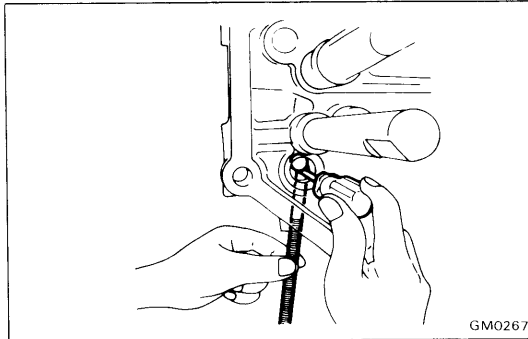

33. INSTALL NO. 4 SHIFT FORK SHAFT, NO. 3 SHIFT FORK AND REVERSE SHIFT HEAD

- (a) Using a magnetic finger and screwdriver, insert the locking ball into the intermediate plate.

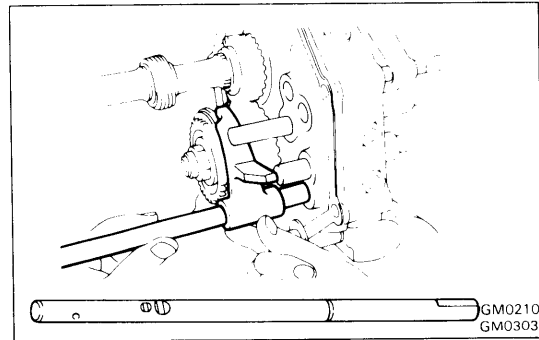

- (b) Place No. 3 shift fork into the groove of No. 3 hub sleeve and install No. 4 fork shaft to No. 3 shift fork.

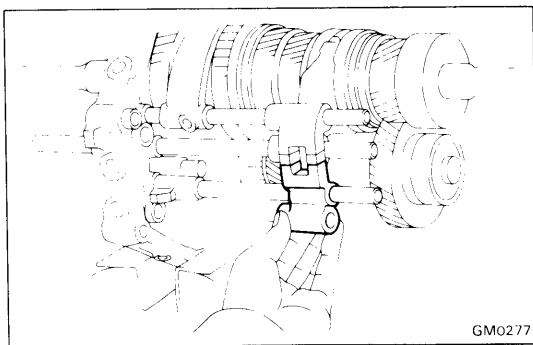

- (c) Install the reverse shift head to No. 3 fork shaft.

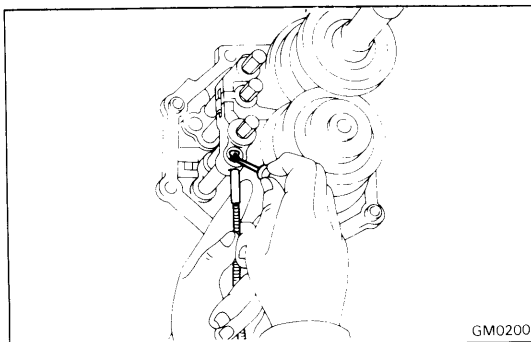

- (d) Using a magnetic finger and screwdriver, insert the locking ball into the reverse shift head hole and install No. 4 fork shaft to the reverse shift head.

34. CHECK INTERLOCK

- (a) Shift No. 1 fork shaft to the 1st speed position.
- (b) No. 2, No. 3 and No. 4 fork shafts should not move.

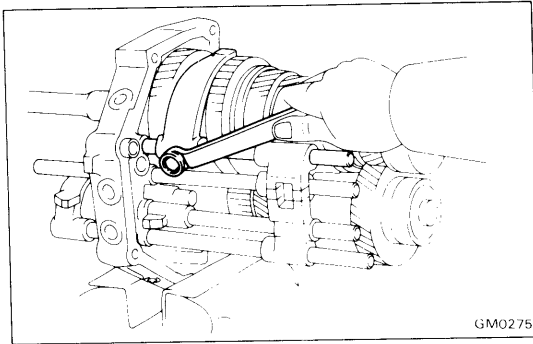

35. INSTALL SLOTTED SPRING PINS AND BOLT

- (a) Install the bolt to No. 1 shift fork.

Torque: 200 kg-cm (14 ft-lb, 20 N·m)

- (b) Using a pin punch and hammer, drive in the slotted spring pins to the reverse shift arm, 1st and 2nd shift head, No. 2 and No. 3 shift forks.

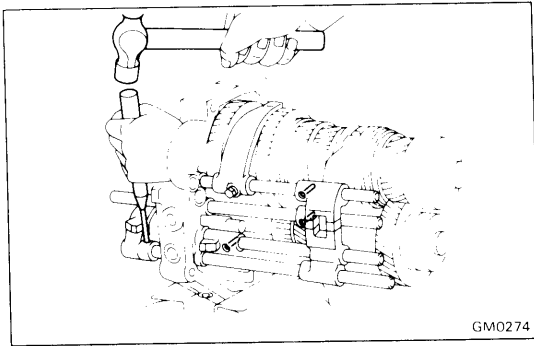

36. INSTALL E-RINGS

Using pliers, install the four E-rings.

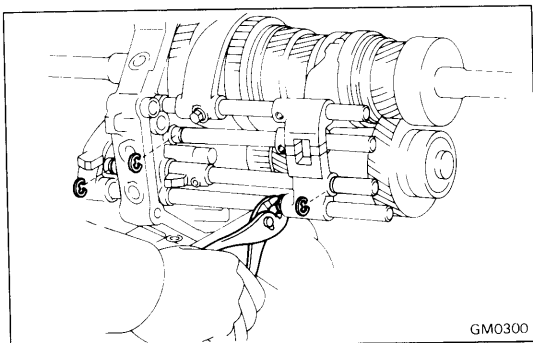

37. INSTALL LOCKING BALLS, SPRINGS AND STRAIGHT SCREW PLUGS

- (a) Apply sealant to the plug threads.

Sealant: Part No. 08833-00080, THREE BOND 1344, LOCTITE 242 or equivalent

- (b) Install the locking balls, springs and screw plugs, and then torque the screw plugs with a torx socket wrench.

Torque: 190 kg-cm (14 ft-lb, 19 N·m)

NOTE: Install the short spring into the bottom of the intermediate plate.

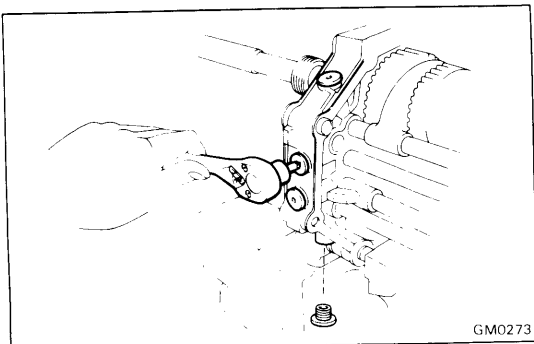

38. REMOVE INTERMEDIATE PLATE FROM VISE

- (a) Remove the intermediate plate from the vise.
- (b) Remove the bolts, nuts, plate washers and gaskets.

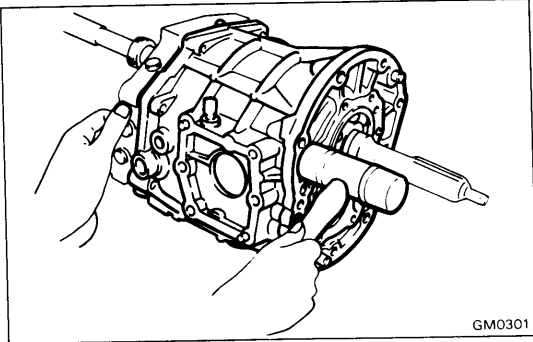
**39. INSTALL TRANSMISSION CASE WITH NEW GASKET TO INTERMEDIATE PLATE**

Align each bearing outer race, each fork shaft end and reverse idler gear shaft end with the case installation holes, and install the case. If necessary, tap on the case with a plastic hammer.

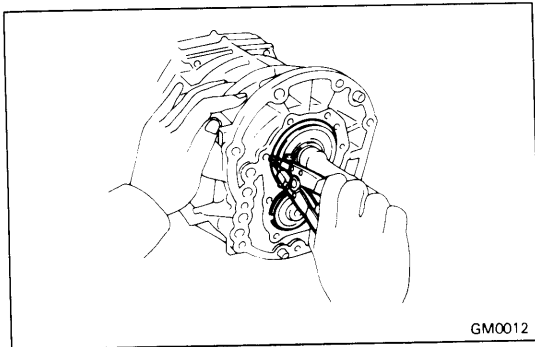
**40. INSTALL BEARING SNAP RINGS**

Using snap ring pliers, install the two snap rings.

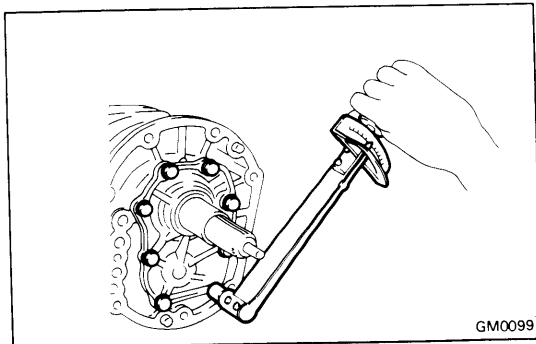
**41. INSTALL FRONT BEARING RETAINER WITH NEW GASKET**

- (a) Install the bearing retainer with a new gasket.
- (b) Apply sealant to the bolt threads.

Sealant: Part No. 08833-00080, THREE BOND 1344, LOCTITE 242 or equivalent

- (c) Install and torque the bolts.

Torque: 170 kg-cm (12 ft-lb, 17 N·m)

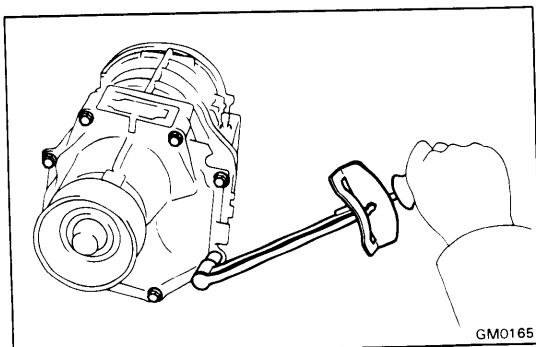
**42.-1 (2WD)****INSTALL EXTENSION HOUSING WITH NEW GASKET**

- (a) Install a new gasket to the intermediate plate.
- (b) Install the extension housing and torque the bolts.

Torque: 380 kg-cm (27 ft-lb, 37 N·m)

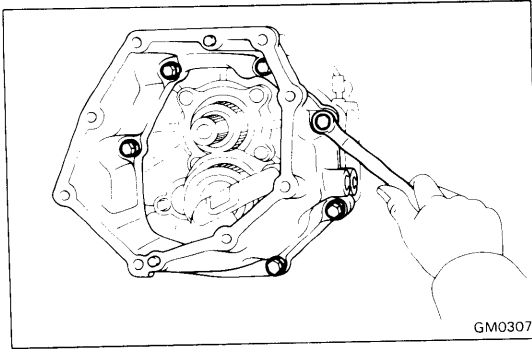

**42.-2 (4WD)
INSTALL TRANSFER ADAPTOR WITH NEW GASKET**

- (a) Install a new gasket to the intermediate plate.
- (b) Apply sealant to the three bolt threads of adaptor inner.

Sealant: Part No. 08833-00080, THREE BOND 1344, LOCTITE 242 or equivalent

- (c) Install the transfer adaptor and torque the bolts.

Torque: 380 kg-cm (27 ft-lb, 37 N·m)

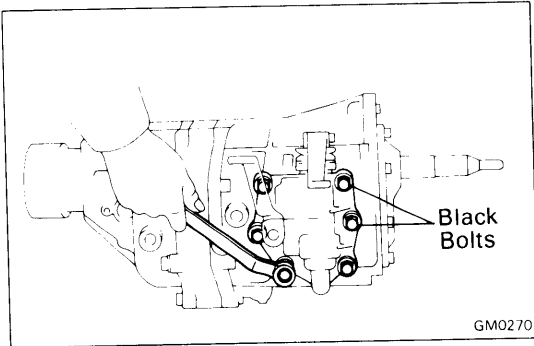

43. INSTALL SHIFT LEVER SHAFT HOUSING ASSEMBLY WITH NEW GASKET

- (a) Install a new gasket to the transmission case.
- (b) Apply sealant to the threads of all bolts except the two black bolts.

Sealant: Part No. 08833-00080, THREE BOND 1344, LOCTITE 242 or equivalent

- (c) Install the shift lever shaft housing and torque the bolts.

Torque: 170 kg-cm (12 ft-lb, 17 N·m)

44. AFTER INSTALLING SHIFT LEVER SHAFT HOUSING, CHECK FOLLOWING ITEMS:

- (a) Check to see that the input shaft and output shaft rotate smoothly.
- (b) Check to see that shifting can be made smoothly to all positions.

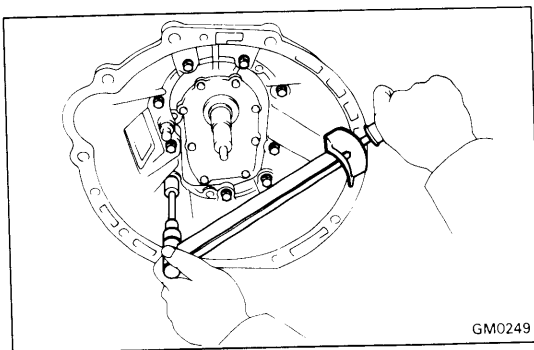

45. INSTALL CLUTCH HOUSING

- (a) Install the clutch housing.
- (b) Install and torque the bolts.

Torque: 380 kg-cm (27 ft-lb, 37 N·m)

46. INSTALL BACK-UP LIGHT SWITCH

Torque: 380 kg-cm (27 ft-lb, 37 N·m)

**47. (2WD)
INSTALL SPEEDOMETER DRIVEN GEAR**

48. INSTALL RELEASE FORK AND BEARING

- (a) Apply molybdenum disulphide lithium base grease to the following parts:
 - Release bearing hub inside groove
 - Input shaft spline
 - Release fork contact surface
- (b) Apply MP grease to the front surface of the release bearing.

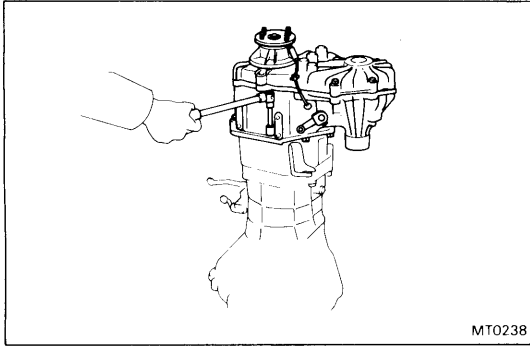

MT0238

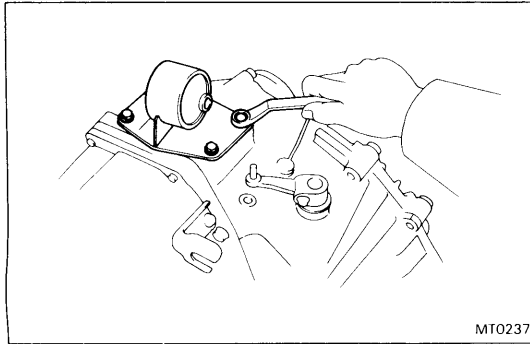

MT0237

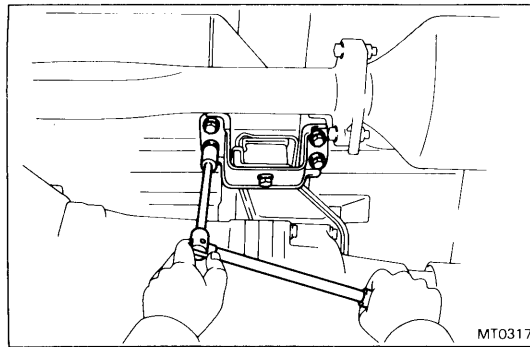

MT0317

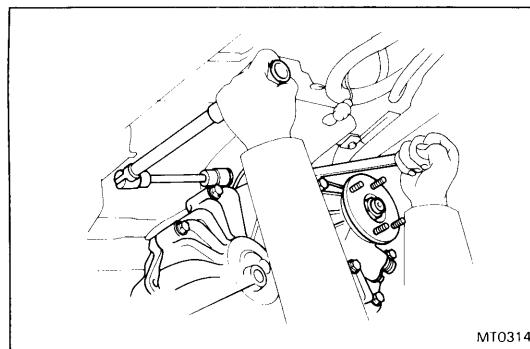

MT0314

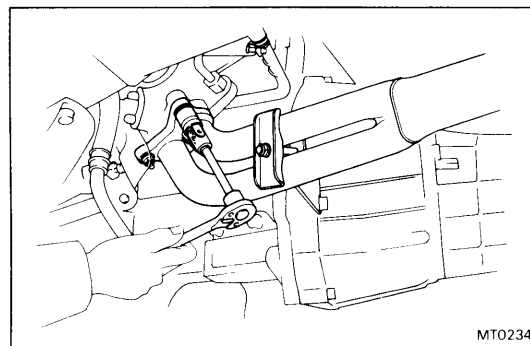

MT0234

INSTALLATION OF TRANSMISSION

1. (4WD)
INSTALL TRANSFER TO TRANSMISSION WITH NEW GASKET
 - (a) Place a new gasket to the transfer adaptor.
 - (b) Install the transfer to the transmission.
 - (c) Apply sealant to the two front bolt threads.
Sealant: Part No. 08833-00080, THREE BOND 1344, LOCTITE 242 or equivalent
 - (d) Install and torque the bolts.
Torque: 380 kg-cm (27 ft-lb, 37 N·m)
 - (e) Install the engine rear mounting.
Torque: 290 kg-cm (21 ft-lb, 28 N·m)

2. **PLACE TRANSMISSION AT INSTALLATION POSITION AND INSTALL TRANSMISSION MOUNTING BOLTS**
 - (a) Align the input shaft spline with the clutch disc, and push the transmission fully into position.
 - (b) Install and torque the transmission mounting bolts.
Torque:
Transmission mounting bolt 730 kg-cm (53 ft-lb, 72 N·m)
Stiffener plate bolt 380 kg-cm (27 ft-lb, 37 N·m)

- 3.-1 (2WD)
CONNECT ENGINE REAR MOUNTING
Torque: 120 kg-cm (9 ft-lb, 12 N·m)

- 3.-2 (4WD)
INSTALL ENGINE REAR MOUNTING BOLT
Torque: 500 kg-cm (36 ft-lb, 49 N·m)

4. **INSTALL STARTER AND CONTROL CABLE BRACKET**

5. **CONNECT EXHAUST FRONT PIPE**
 - (a) Connect the exhaust front pipe to the exhaust manifold.
Torque: 630 kg-cm (46 ft-lb, 62 N·m)
 - (b) Install the exhaust front pipe clamp to the bracket.

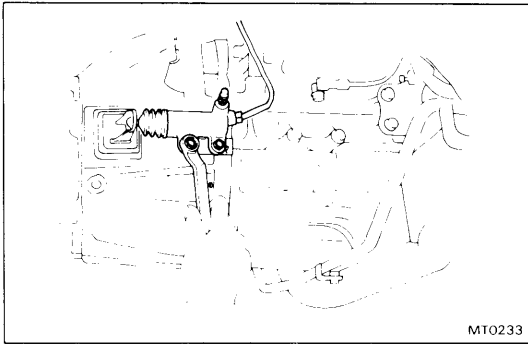

6. INSTALL CLUTCH RELEASE CYLINDER

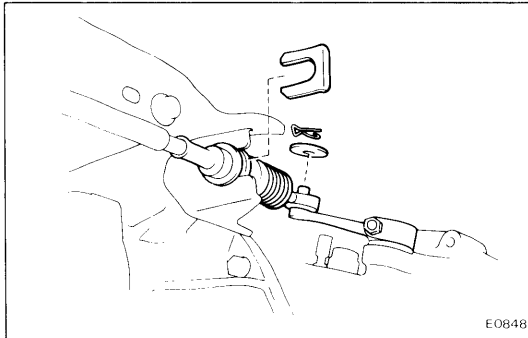

**7. (4WD)
CONNECT TRANSFER CONTROL CABLE**

- (a) Install the control cable to the bracket and clip.
- (b) Connect the control cable to the outer lever.

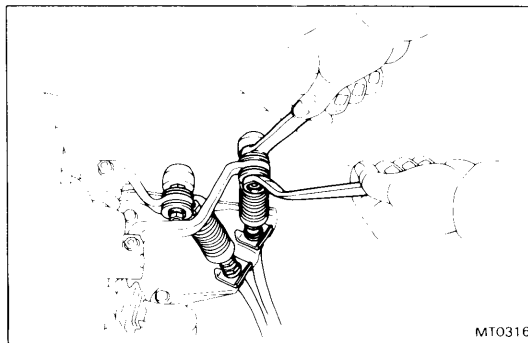

8. CONNECT TRANSMISSION CONTROL CABLES

- (a) Install the control cables to the bracket and clip.
- (b) Connect the control cables to the outer levers.

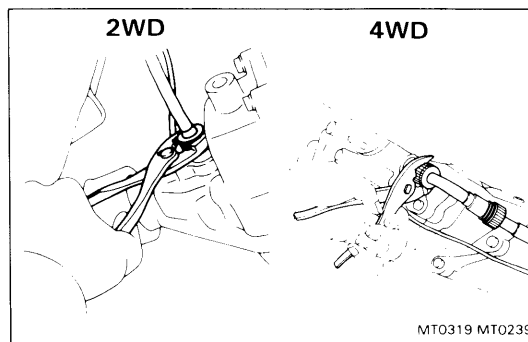

9. CONNECT SPEEDOMETER CABLE AND GROUND STRAP

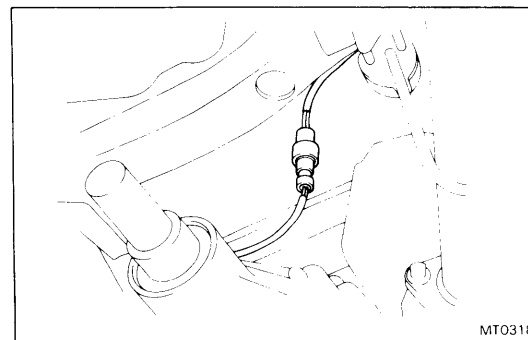

**10. (4WD)
CONNECT TRANSFER INDICATOR SWITCH CONNECTOR**

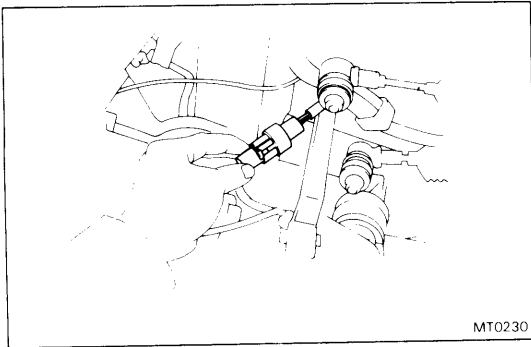
11. CONNECT BACK-UP LIGHT SWITCH CONNECTOR**12.-1 (2WD)
INSTALL PROPELLER SHAFT**

- (a) Remove SST and insert the yoke into the transmission. SST 09325-20010
- (b) Align the matchmarks on the flanges and connect the propeller shaft with the four bolts and nuts.
- (c) Torque the bolts and nuts.

Torque: 750 kg-cm (54 ft-lb, 74 N·m)

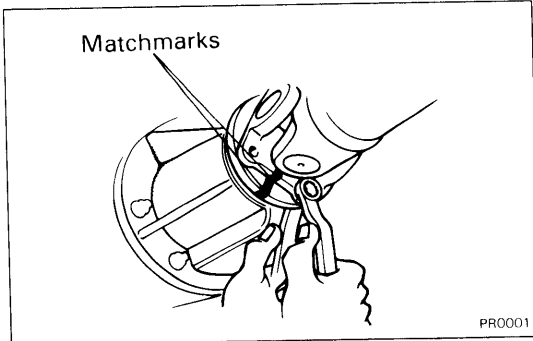
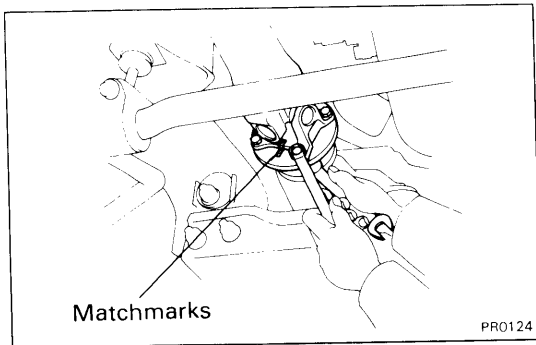
**12.-2 (4WD)
INSTALL FRONT AND REAR PROPELLER SHAFTS
(See page PR-6)****13. FILL TRANSMISSION WITH OIL**

Oil grade: API GL-4 or GL-5

Viscosity: SAE 75W-90

Capacity:

2WD 2.2 liters (2.3 US qts, 1.9 Imp. qts)

4WD 2.6 liters (2.7 US qts, 2.3 Imp. qts)

14. LOWER VEHICLE**15. CONNECT BATTERY CABLE TO NEGATIVE TERMINAL****16. PERFORM ROAD TEST**

Check for abnormal noise or operation.

SHIFT LEVER AND CONTROL CABLE COMPONENTS

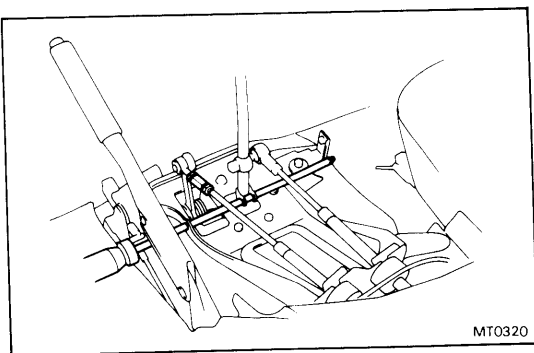
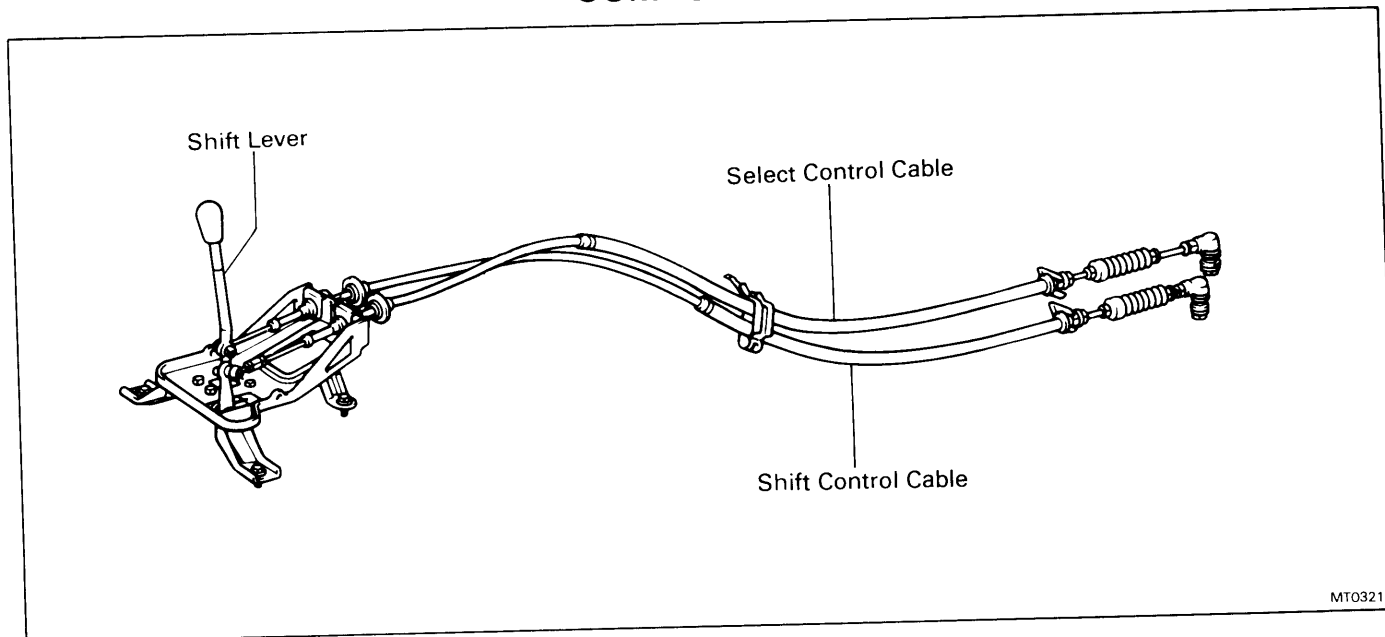

ADJUSTMENT OF SHIFT LEVER NEUTRAL POSITION

1. REMOVE CONSOLE ASSEMBLY
2. CONFIRM THAT SHIFT LEVER IS IN NEUTRAL POSITION
3. CHECK SHIFT LEVER NEUTRAL POSITION
Check that the guide pin inserts smoothly into the shift lever retainer hole and shift lever inspection hole.
NOTE: Use a 6 mm (0.24 in.) diameter guide pin.
4. IF NECESSARY, ADJUST SHIFT LEVER NEUTRAL POSITION
 - (a) Loosen the adjusting nut lock nuts and adjust the length of the select control cable so that the guide pin inserts smoothly into the holes.
 - (b) Tighten the lock nuts.
5. INSTALL CONSOLE ASSEMBLY

