

FRONT WINCH

	Page
CUTAWAY VIEW	10-2
POWER TAKE OFF	10-4
MECHANICAL WINCH	10-11
ELECTRIC WINCH	10-17

CUTAWAY VIEW

Fig. 10-1

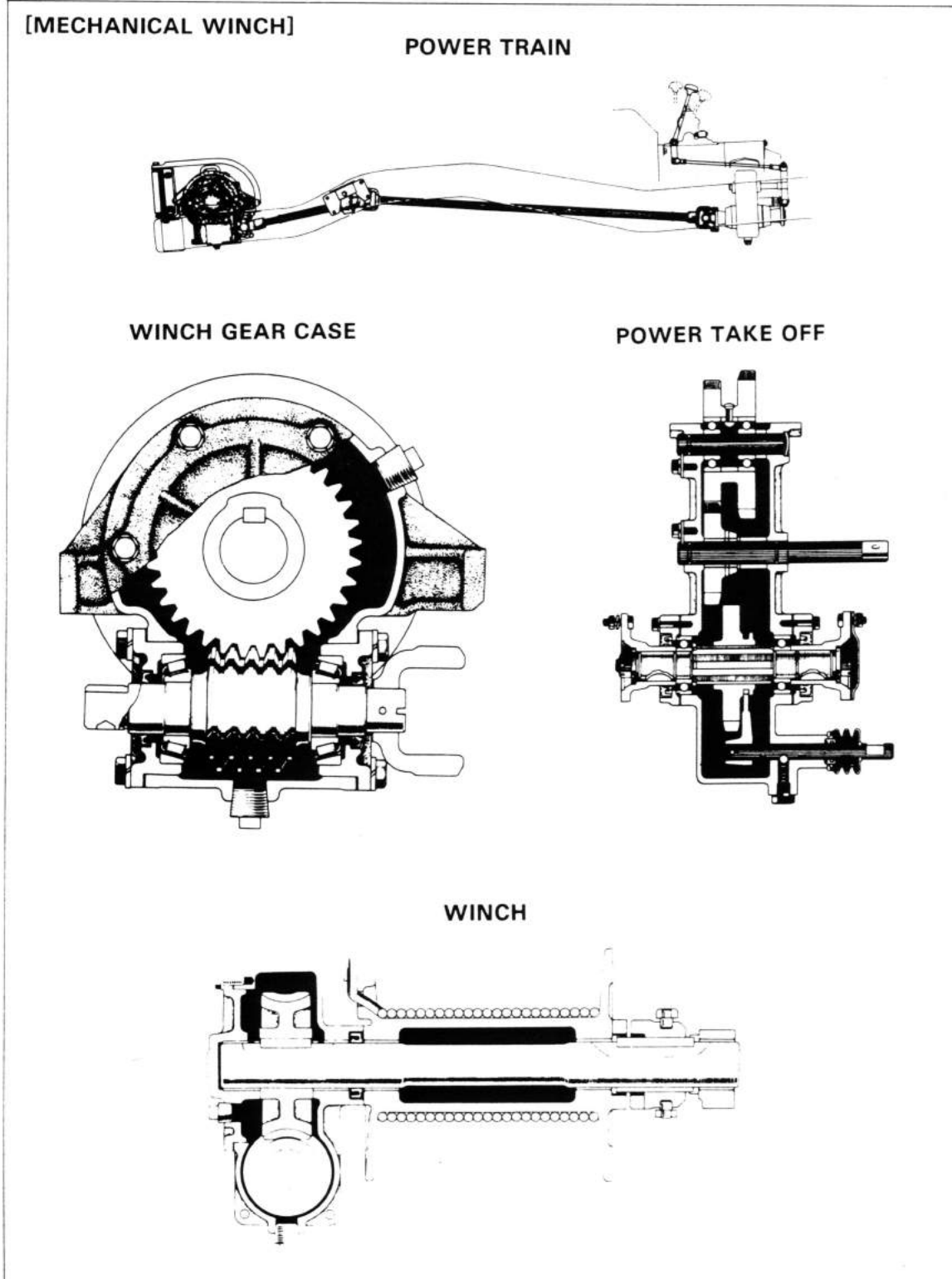
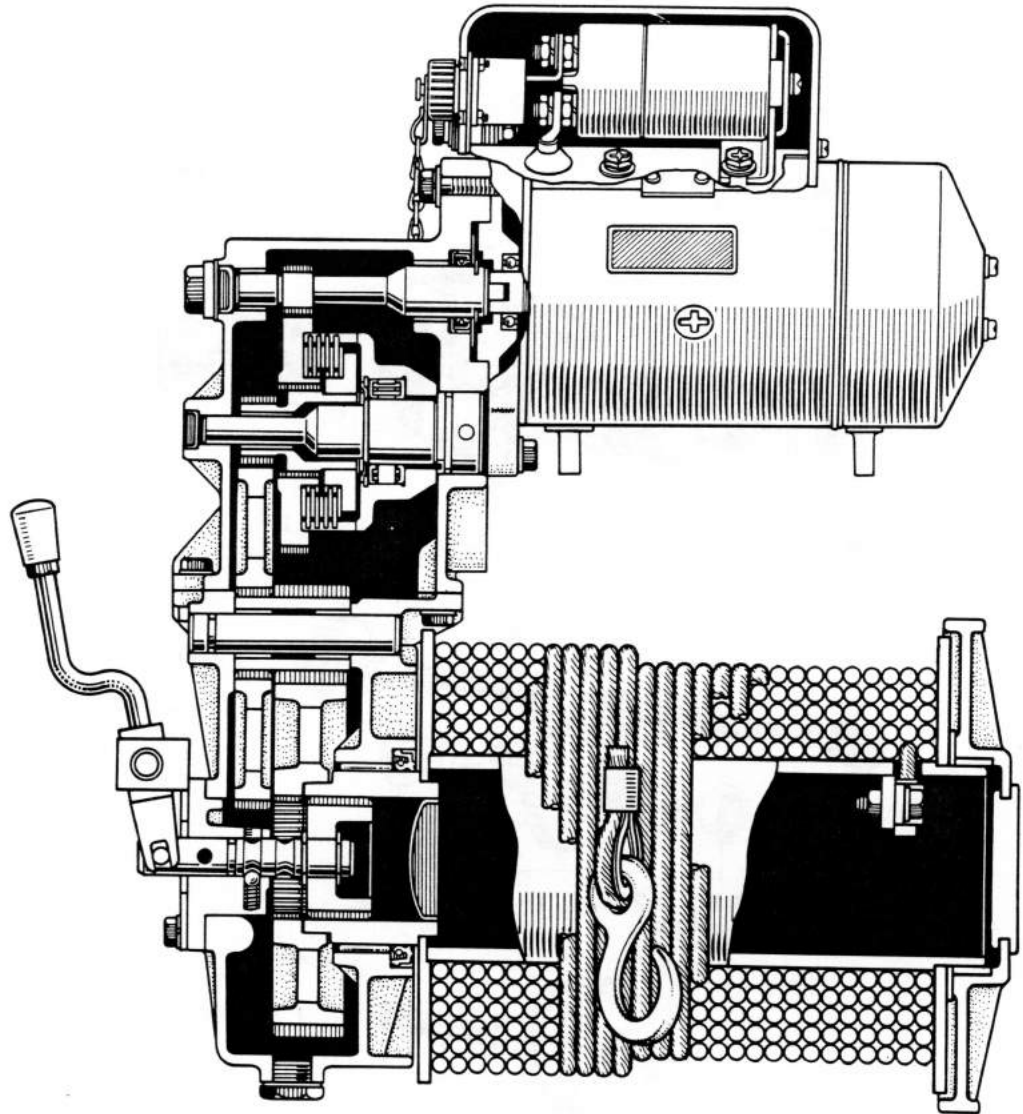

Fig. 10-2

[ELECTRIC WINCH]



POWER TAKE OFF**DISASSEMBLY**

Disassemble the parts in the numerical order shown in the figure.

Fig. 10-3

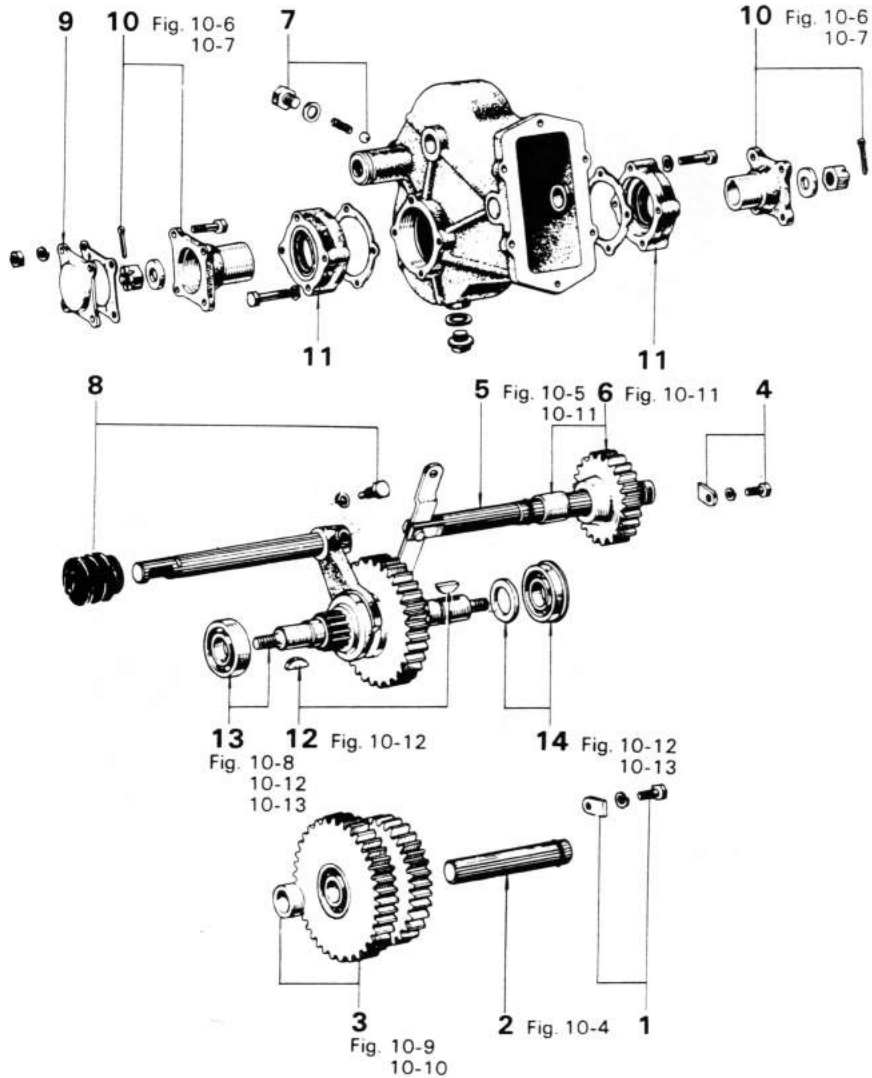

- | | |
|---------------------------------|---|
| 1. Lock Plate | 8. Lock Bolt, Fork Shaft, Boot & Shift Fork |
| 2. Input Gear Shaft | 9. Retainer Cap |
| 3. Spacer, Input Gear & Bearing | 10. Nut, Plate & Joint Flange |
| 4. Lock Plate | 11. Bearing Retainer |
| 5. Reverse Idler Shaft | 12. Woodruff Key |
| 6. Reverse Idler Gear & Spacer | 13. Output Shaft & Bearing |
| 7. Lock Ball & Spring | 14. Spacer & Bearing |

Fig. 10-4

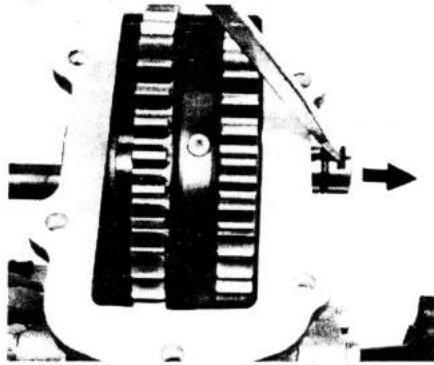

Remove the input gear shaft.

— Note —

If difficult to remove the shaft, first tap the shaft lightly towards the front, and remove the expansion plug.

Fig. 10-5

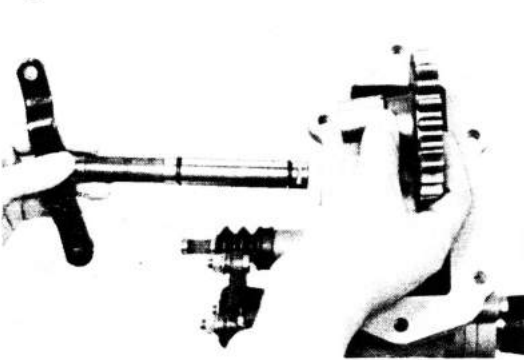

Remove the reverse idler shaft assembly.

Fig. 10-6

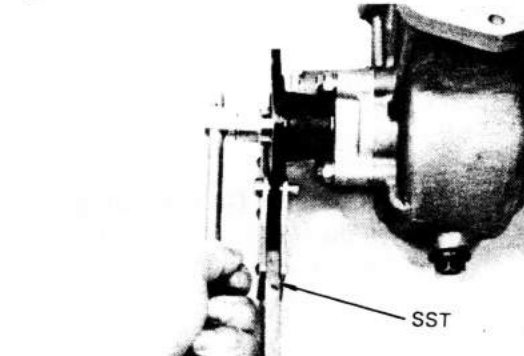

Remove the joint flange with SST.
SST [09330-00020]

Fig. 10-7

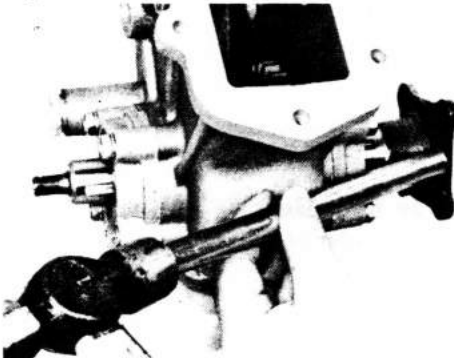

Remove the joint flange by lightly tapping its portion of woodruff key groove.

Fig. 10-8

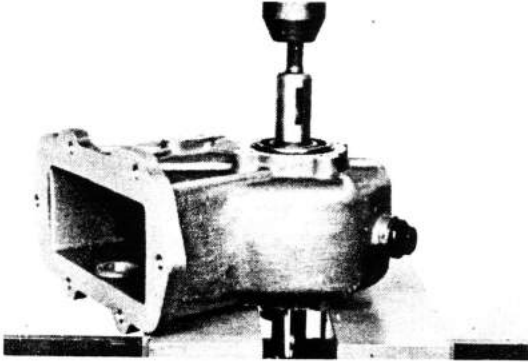

Remove the output shaft with the rear bearing using a press.

Fig. 10-9

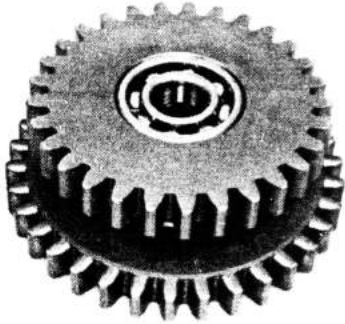
**INSPECTION****Input Gear & Bearing**

1. Inspect the gears for teeth wear or damage.
2. Inspect the bearings for wear or damage.

Fig. 10-10

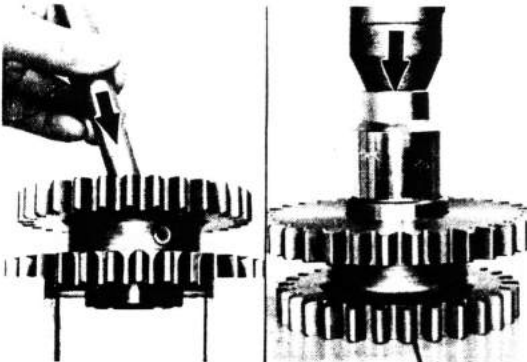
**Replace The Input Gear Bearing**

1. Remove the bearings with drift pin.
2. Install the bearings with socket wrench.

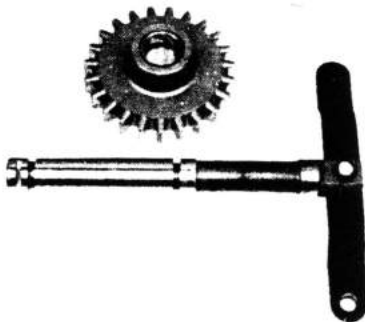
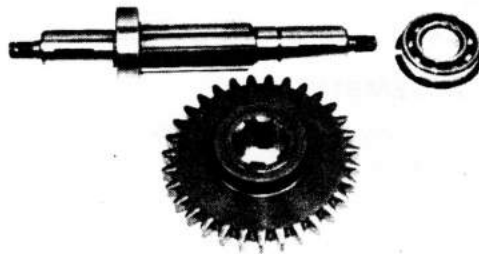

Fig. 10-11

**Reverse Idler Gear & Shaft**

Inspect for wear or damage.

Fig. 10-12

**Output Gear, Shaft & Bearing**

1. Inspect for wear or damage.

Fig. 10-13

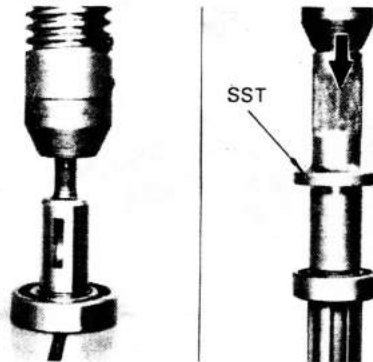
**Replace The Output Gear Bearing**

1. Remove the bearing with a press.
2. Install the bearing with a press and SST.
SST [09325-12010]



ASSEMBLY

Assemble the parts in the numerical order shown in the figure.

Fig. 10-14

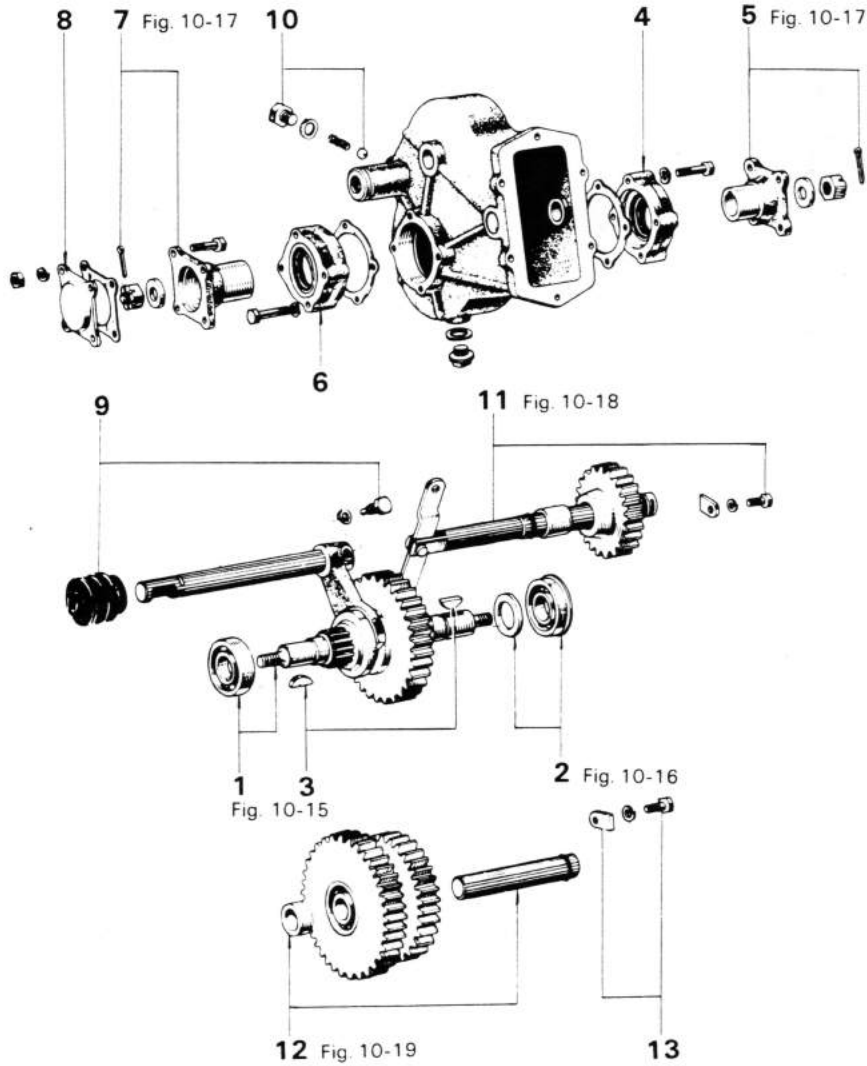

- | | | | |
|---|------------------------|----|------------------------------------|
| 1 | Output Shaft & Bearing | 8 | Retainer Cap |
| 2 | Spacer & Bearing | 9 | Shift Fork, Shaft & Boot |
| 3 | Woodruff Key | 10 | Lock Ball & Spring |
| 4 | Bearing Retainer | 11 | Reverse Idler Gear, Spacer & Shaft |
| 5 | Joint Flange | 12 | Input Gear & Shaft |
| 6 | Bearing Retainer | 13 | Lock Plate |
| 7 | Joint Flange | | |

Fig. 10-15

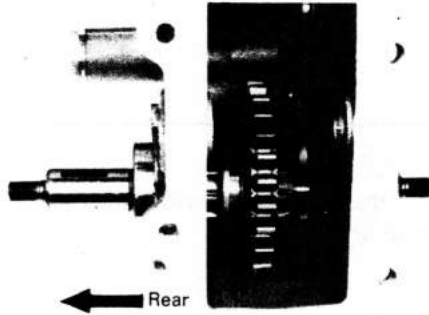

Position the output gear into the case with the shift fork groove towards the rear.

Fig. 10-16

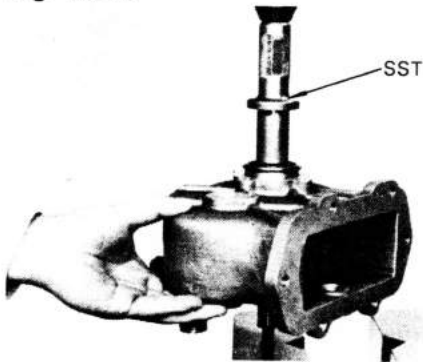

Install the bearing with a press and SST. SST [09325-12010]

Fig. 10-17

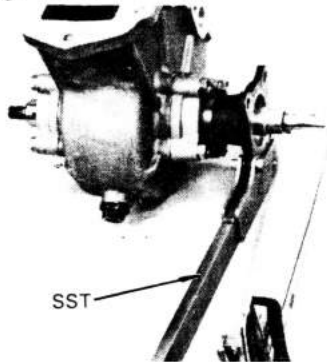

Tighten the nut with SST. SST [09330-00020]

Tightening torque: 3.5 – 5.5 kg-m
(26 – 39 ft-lb)

Fig. 10-18

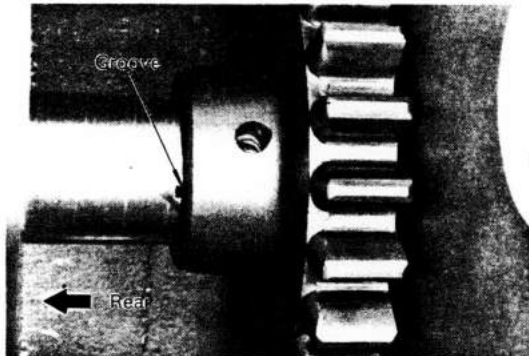

Place the reverse idler gear and the idler gear spacer into the case with the gear hub to the rear side.

The spacer should be installed between the gear hub and the case.

Fig. 10-19

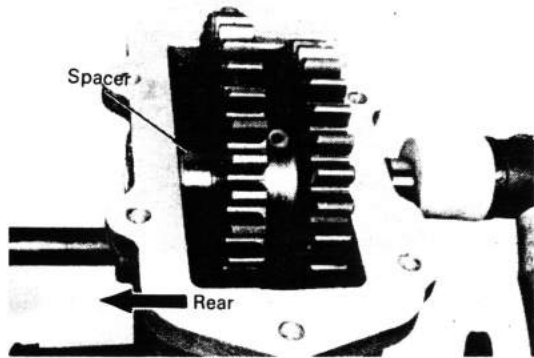

Install the input gear with the larger gear towards the rear.

MECHANICAL WINCH

DISASSEMBLY

Disassemble the parts in the numerical order shown in the figure.

Fig. 10-20

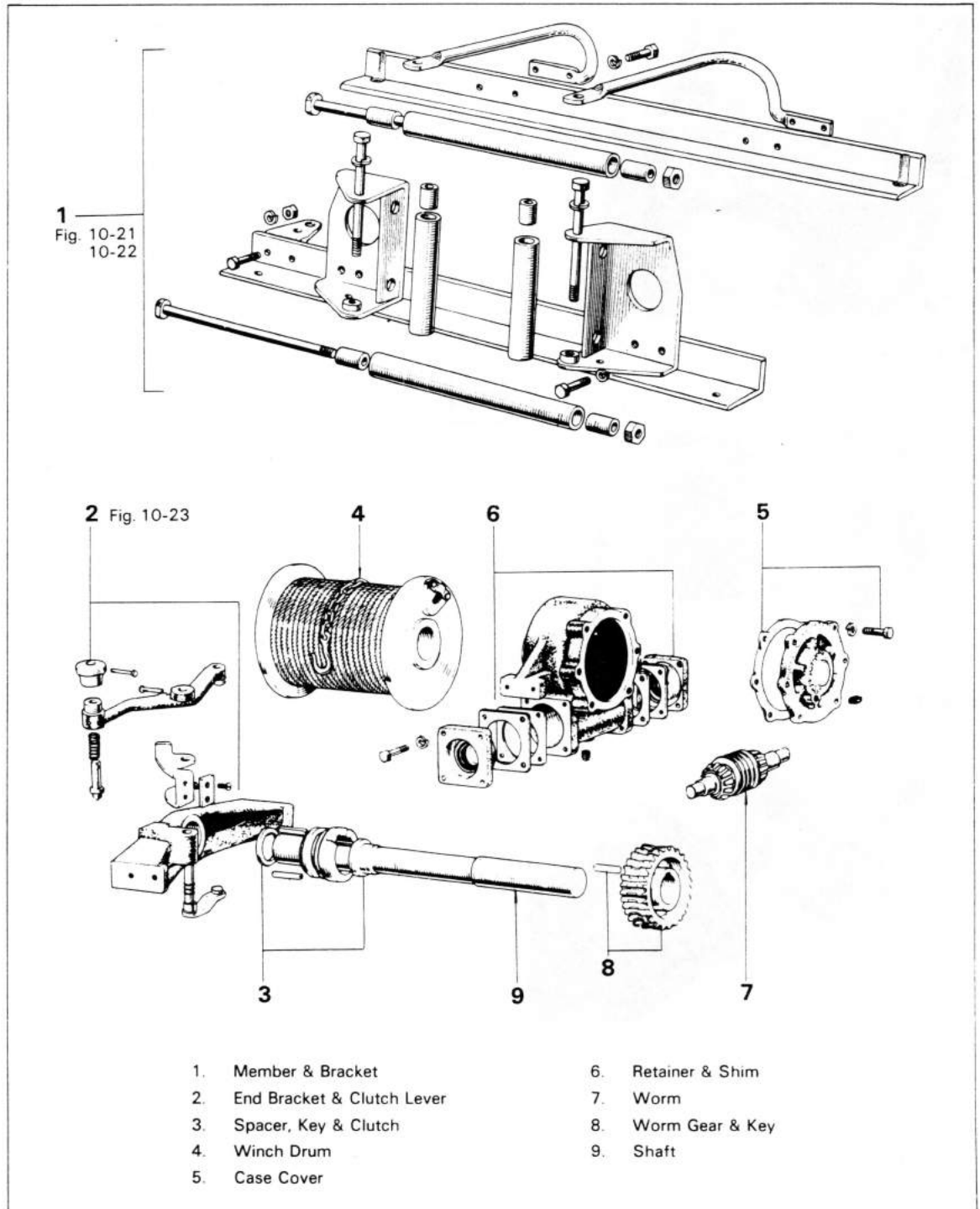
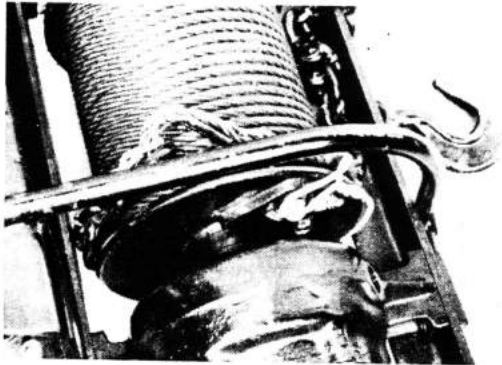
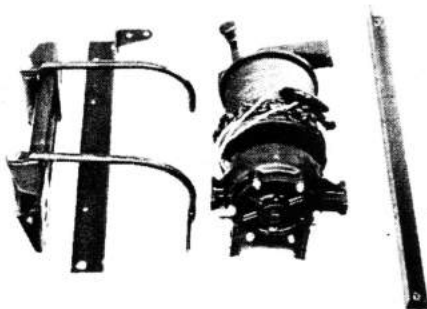

Fig. 10-21



Keep the wire rope end tied together with a wire as shown in the figure.

Fig. 10-22



Remove the front and rear base members, and the roller bracket supports.

Fig. 10-23

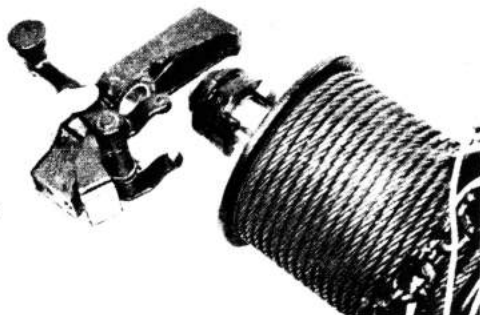

Remove the winch end bracket assembly.

Fig. 10-24

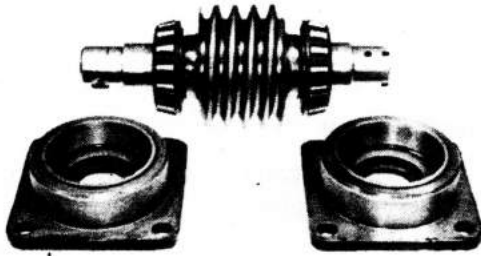

INSPECTION

Worm & Bearing

Inspect for wear or damage.

Fig. 10-25

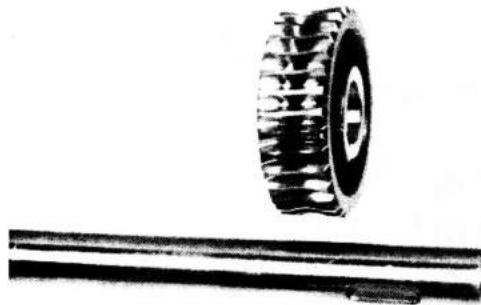

Worm Gear & Shaft

Inspect for wear or damage.

Fig. 10-26

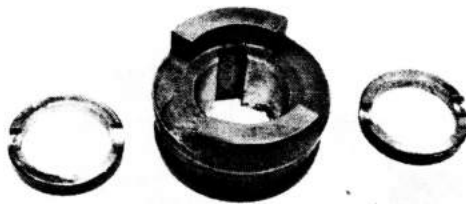

Clutch & Spacer

Inspect for wear or damage.

Fig. 10-27

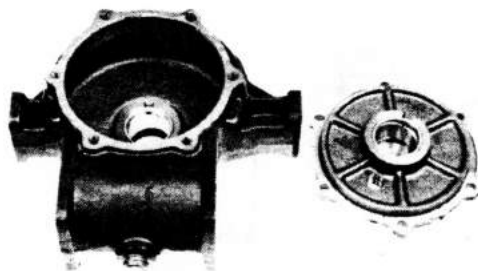

Gear Case & Cover

Inspect for cracks or wear.

ASSEMBLY

Assemble the parts in the numerical order shown in the figure.

Fig. 10-28

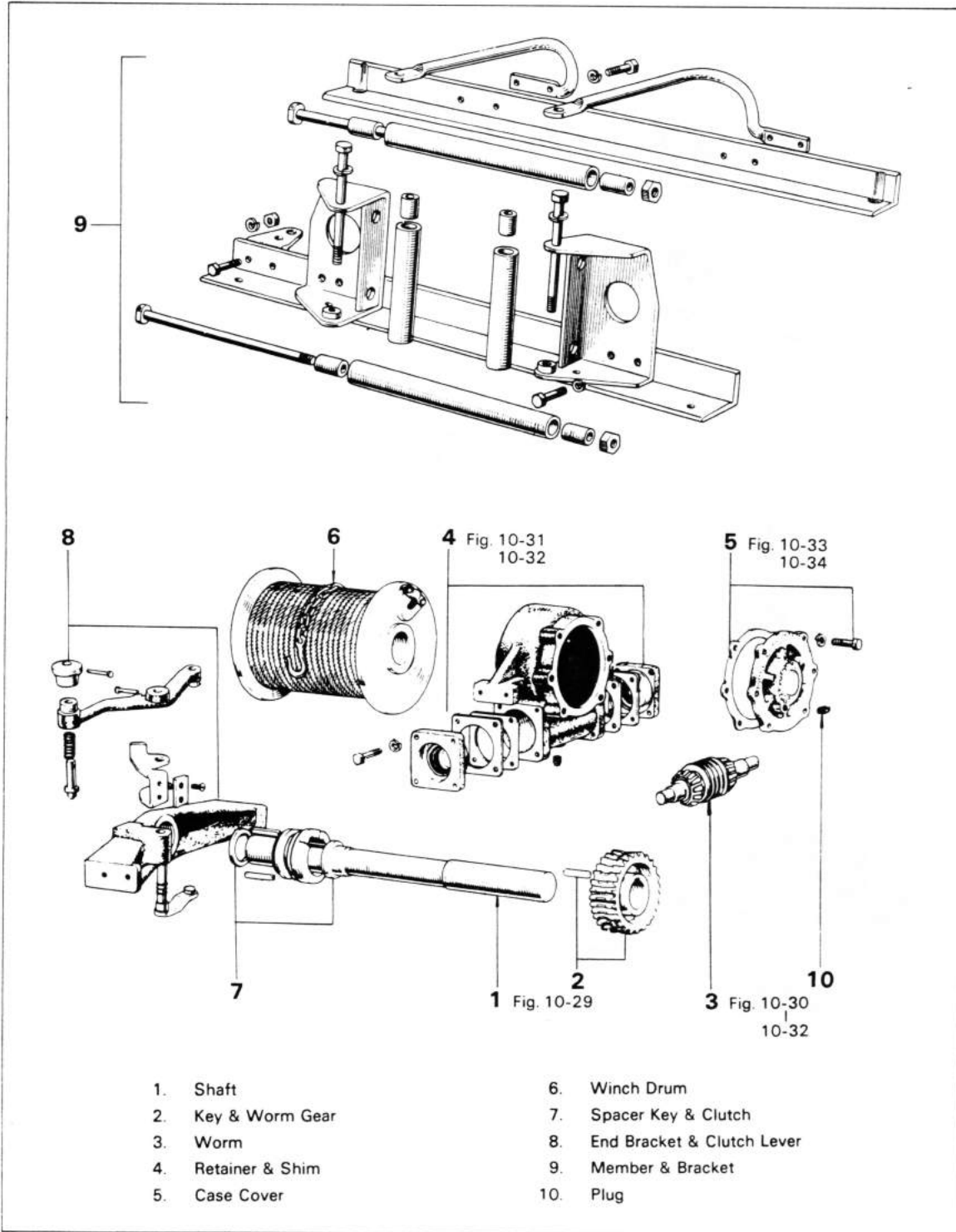
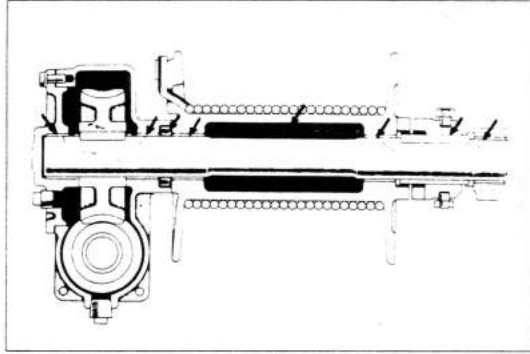
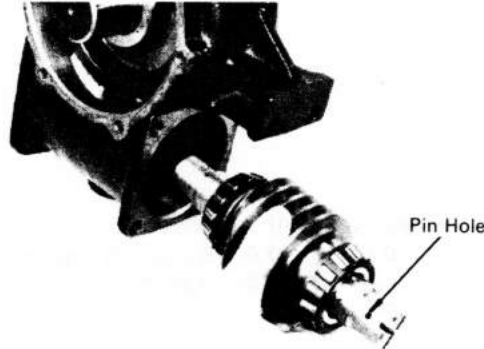

Fig. 10-29



Apply MP grease on all bushings, shaft and the clutch mechanism when assembling, and pack MP grease into the drum to about three-fourth of the drum volume.

Fig. 10-30



Place the worm into the case with the straight pin hole towards the rear.

Fig. 10-31

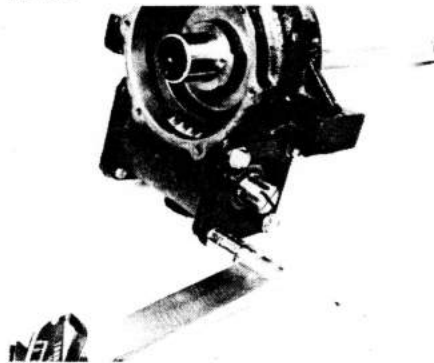

Install the worm bearing retainers with the adjusting shims and tighten the bearing retainer attaching bolts.

**Tightening torque: 1.9 – 3.1 kg-m
(14 – 22 ft-lb)**

– Note –

Apply liquid sealer onto the gasket surfaces to prevent oil leak.

Fig. 10-32



Rotate the worm, and check the condition for looseness or tightness, and also rock the worm to-and-fro, and check the worm end play.

The worm end play should be zero and it should rotate smoothly.

Adjusting shim thickness

Part No.	Thickness mm (in.)
38123-60010	0.228 (0.0090)
38124-60010	0.5 (0.020)

cardiagn.com

Fig. 10-33

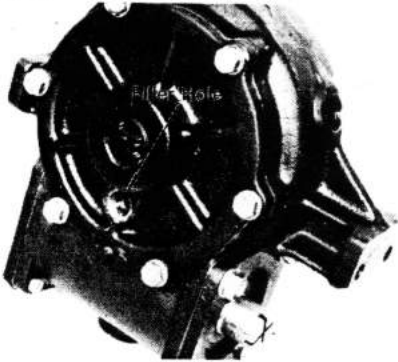

Install the case cover with its filler hole positioned downward.

Fig. 10-34

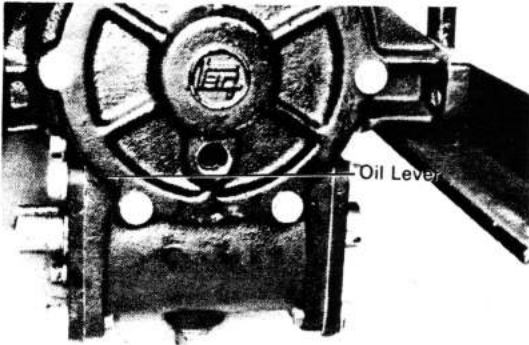

Fill the gear case with gear oil.

Gear case oil capacity:

0.6 liter (0.6 US qt., 0.5 Imp.qt.)

Type: SAE 90, API GL-4

ELECTRIC WINCH

REMOVAL

Remove the parts in the numerical order shown in the figure.

Fig. 10-35

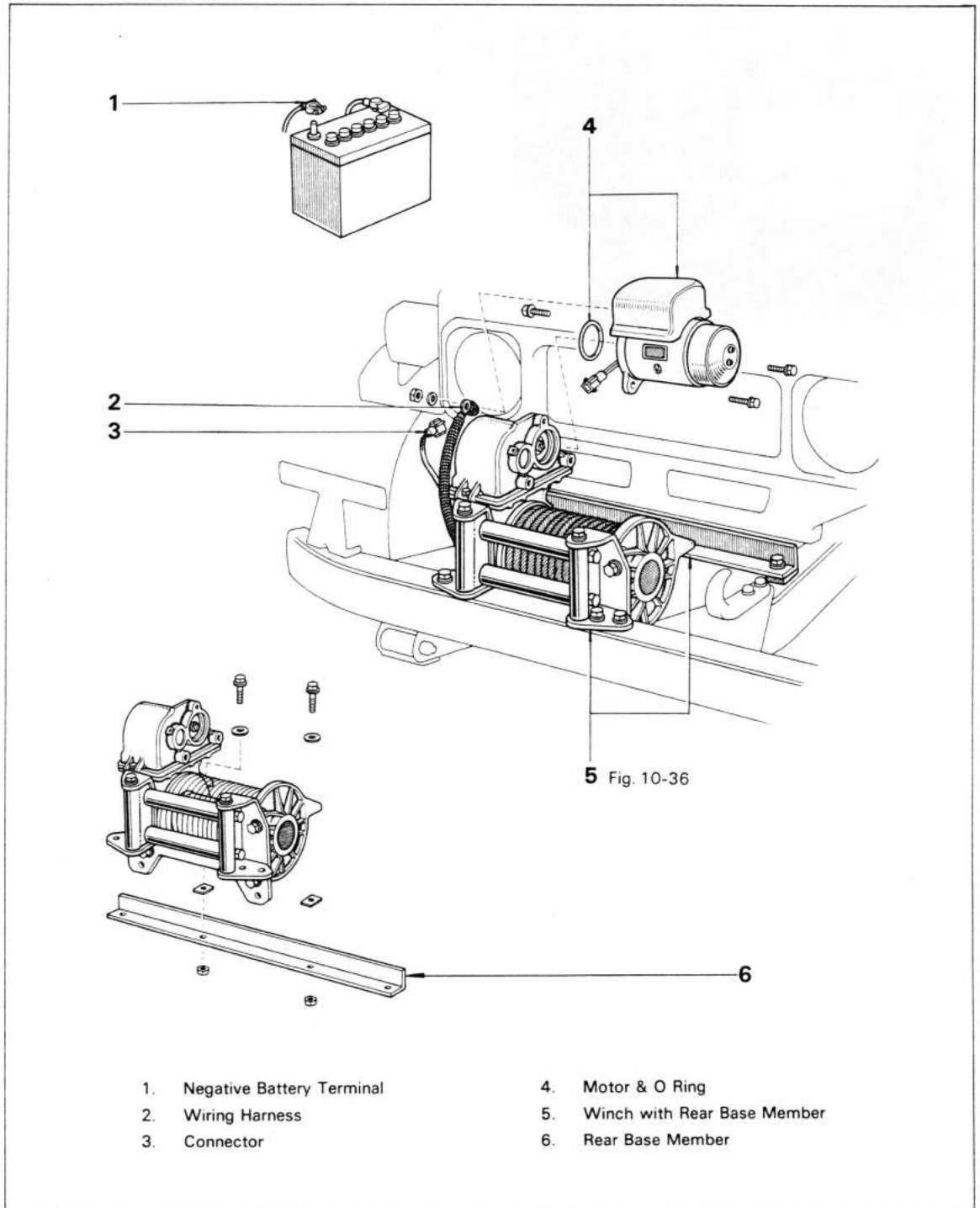

cardiagn.com

Fig. 10-36

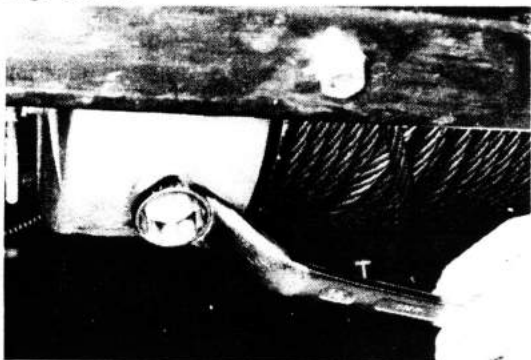

Drain the fluid.

DISASSEMBLY

1. Disassemble the winch in the numerical order shown in the figure.

Fig. 10-37

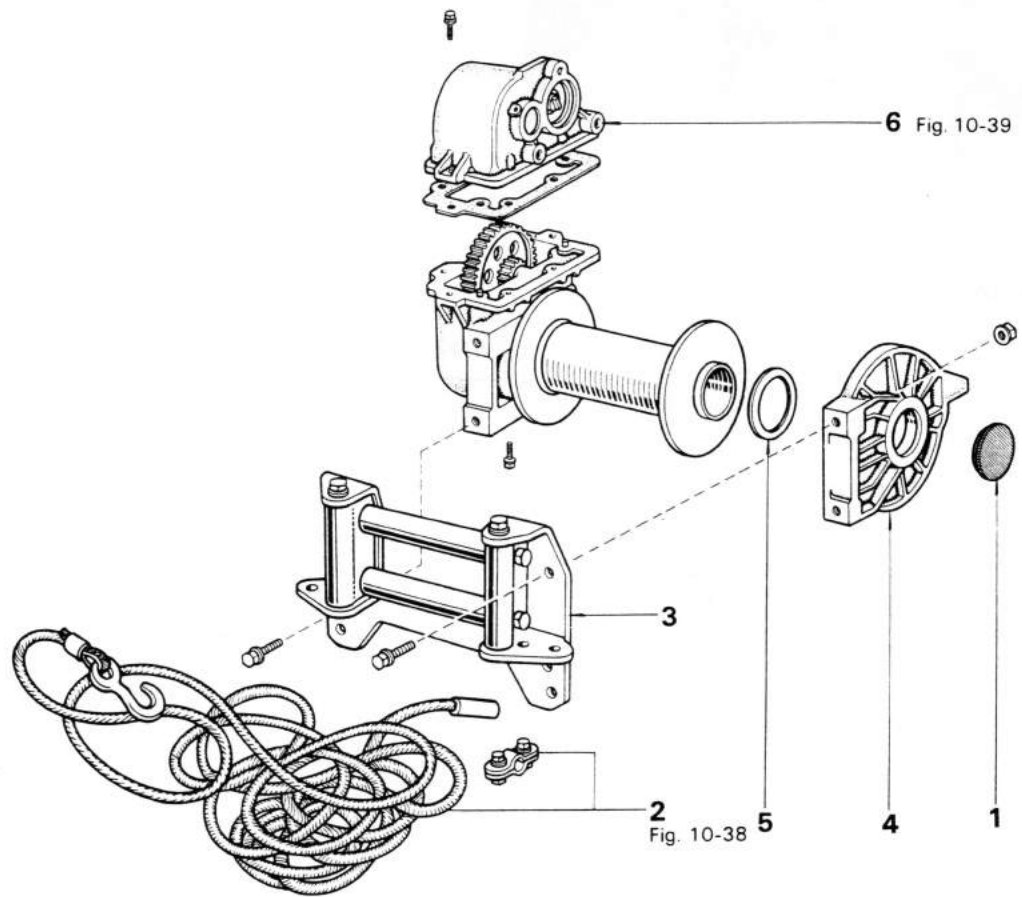

1. Housing Cover
2. Cable
3. Winch Set Plate
4. Winch Housing
5. Drum Spacer
6. Case Cover

Fig. 10-38

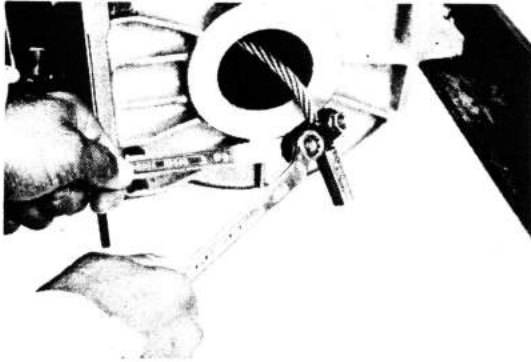

Remove the winch cable.

Fig. 10-39

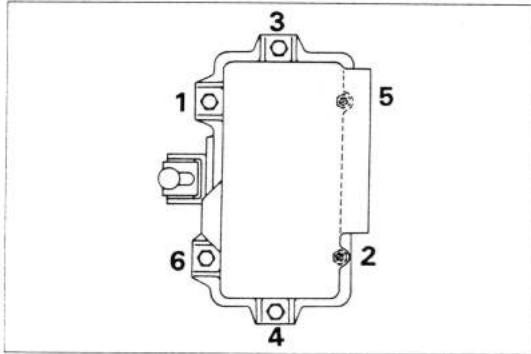

Loosen each bolt a little at a time, and in the sequence shown in figure.

2. Disassemble the case cover in the numerical order shown in the figure.

Fig. 10-40

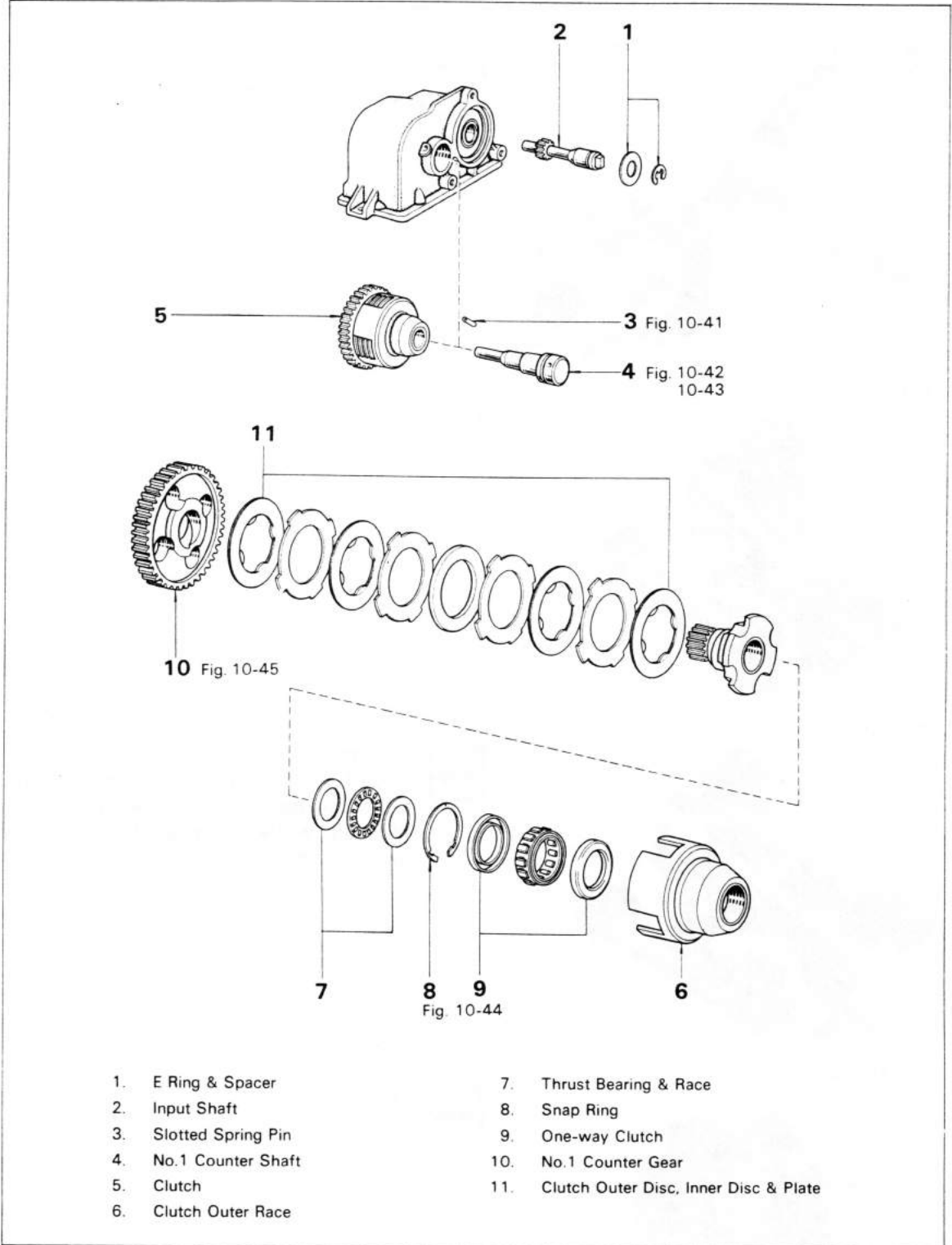

- | | |
|-----------------------|---|
| 1. E Ring & Spacer | 7. Thrust Bearing & Race |
| 2. Input Shaft | 8. Snap Ring |
| 3. Slotted Spring Pin | 9. One-way Clutch |
| 4. No.1 Counter Shaft | 10. No.1 Counter Gear |
| 5. Clutch | 11. Clutch Outer Disc, Inner Disc & Plate |
| 6. Clutch Outer Race | |

Fig. 10-41



Remove the slotted spring pin with a pin punch.

Fig. 10-42



Tap the case cover with a plastic hammer and remove the No.1 counter shaft.

Fig. 10-43



— Note —
If No.1 counter shaft is difficult to remove, lightly tap out the case cover with a plastic hammer while rotating the clutch sub-assembly by hand.

Fig. 10-44



Remove the snap ring.

Fig. 10-45



Remove No.1 counter gear.

3. Disassemble the winch case in the numerical order shown in the figure.

Fig. 10-46

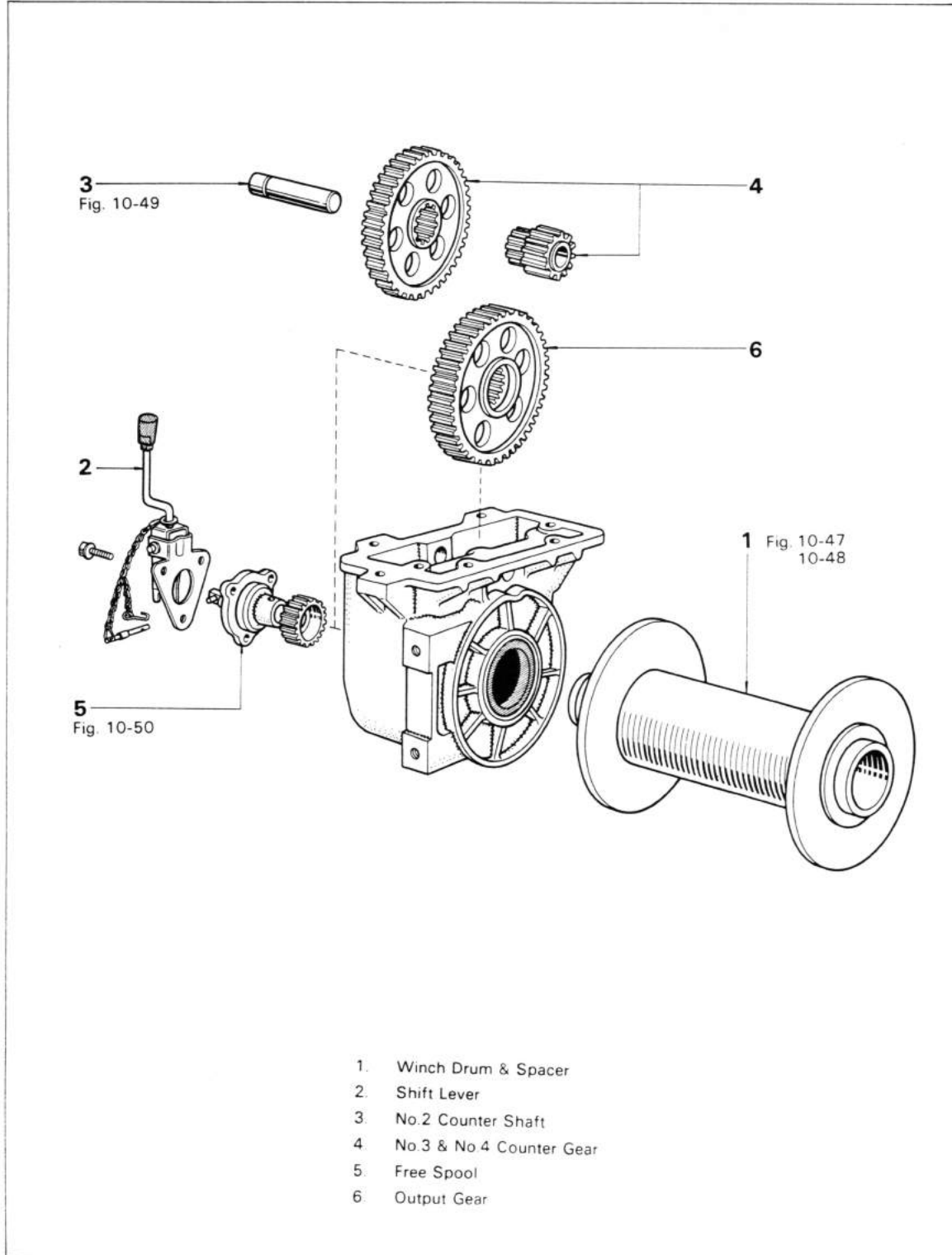
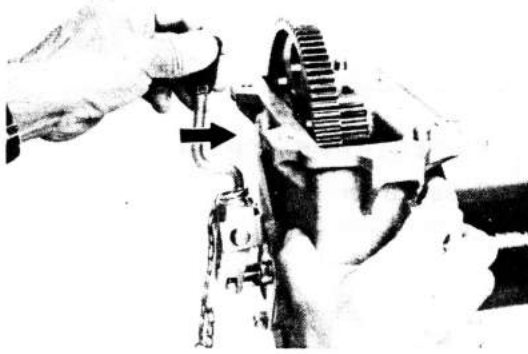
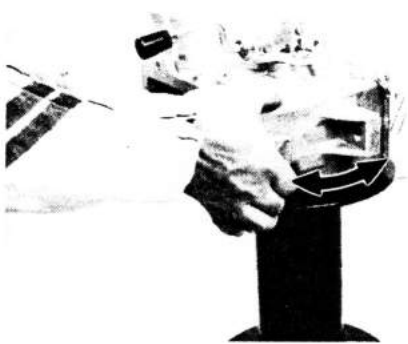

Fig. 10-47



Before removing the winch drum, shift the lever to the lock position.

Fig. 10-48



Remove the winch drum.

Fig. 10-49

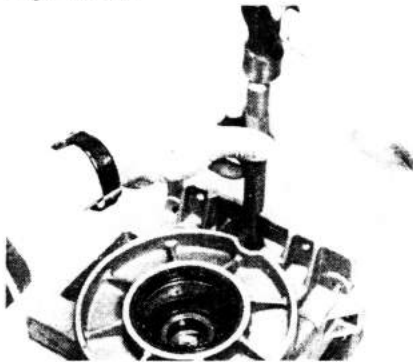

Tap out No.2 counter shaft.

Fig. 10-50



— Note —
Be careful when removing the shift retainer as the steel ball may fly out.

Fig. 10-51

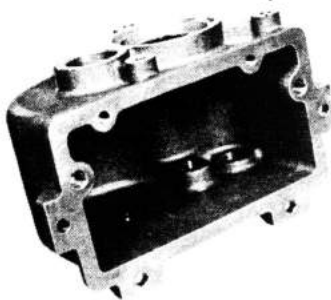

INSPECTION & REPAIR

Case Cover

Check for damage.

Fig. 10-52

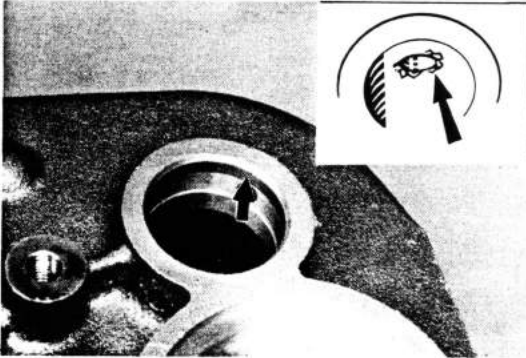

Check the slotted spring hole for bits of debris.

Fig. 10-53

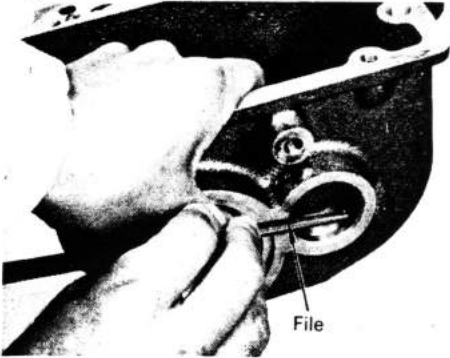

Thoroughly remove all debris from the hole as it will cause damage to the O ring.

Fig. 10-54

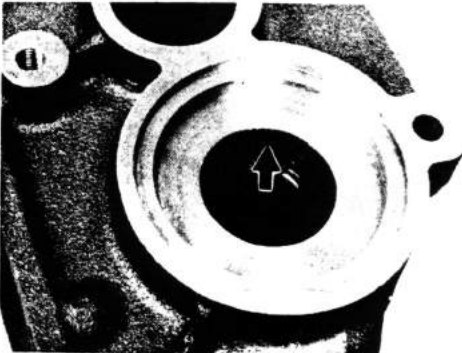

Oil Seal

1. Check the lip for wear or damage

Fig. 10-55

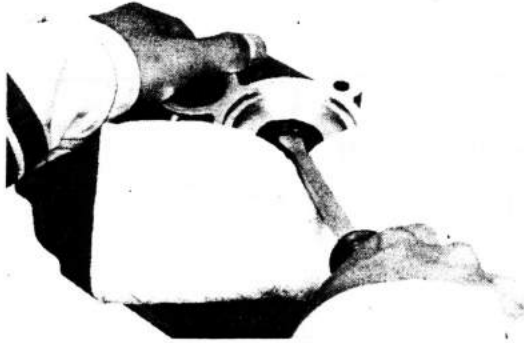

2. Replace the oil seal.
 - (1) Remove the oil seal.

Fig. 10-56

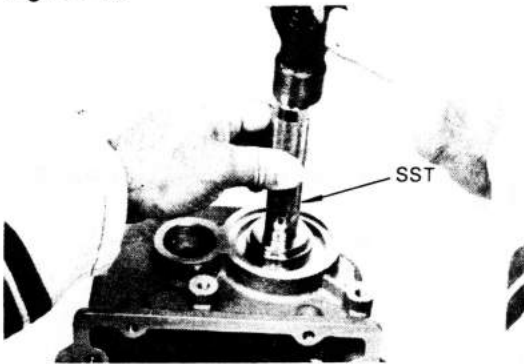

- (2) Install the oil seal with SST. SST [09608-30021]

Fig. 10-57

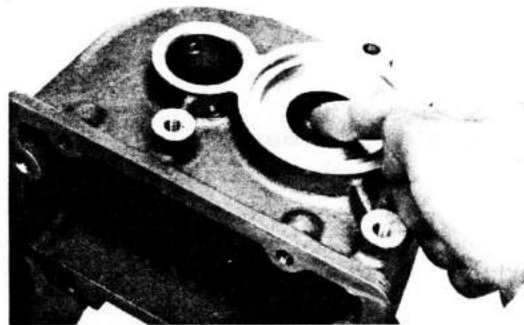

3. Coat the lip with MP grease.

Fig. 10-58

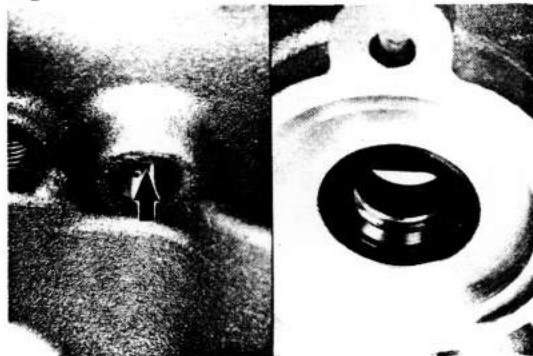

Bushing

Check for wear or damage. If found, replace the case cover.

Fig. 10-59

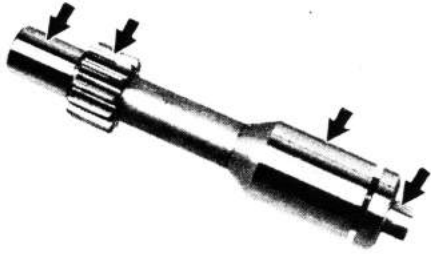

Input Shaft

Check for wear or damage.

Fig. 10-60

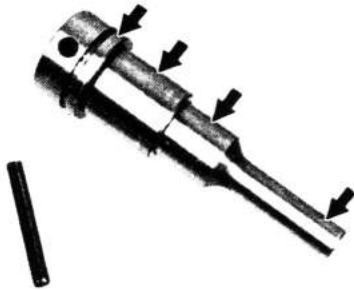

No.1 Counter Shaft & Slotted Spring Pin

Check for wear or damage.

Fig. 10-61

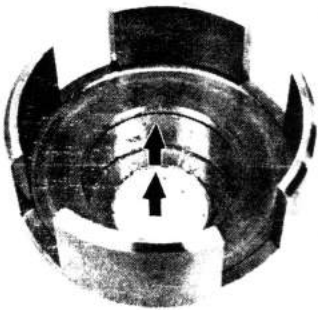

Outer Race & Bushing

Check for wear or damage.

Fig. 10-62

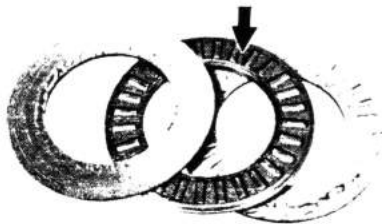

Thrust Bearing & Race

Check for burning, wear or damage

Fig. 10-63

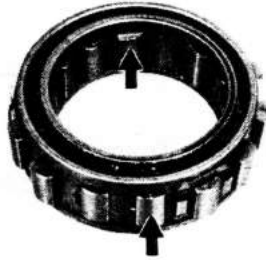

One-way Clutch

Check for wear or damage.

Fig. 10-64

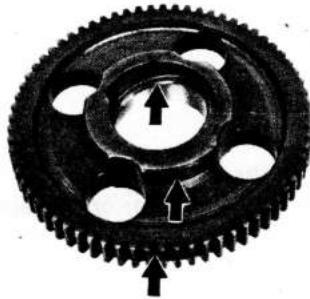

No.1 Counter Gear

Check for wear or damage.

Fig. 10-65



No.2 Counter Gear

1. Check for wear or damage.

Fig. 10-66

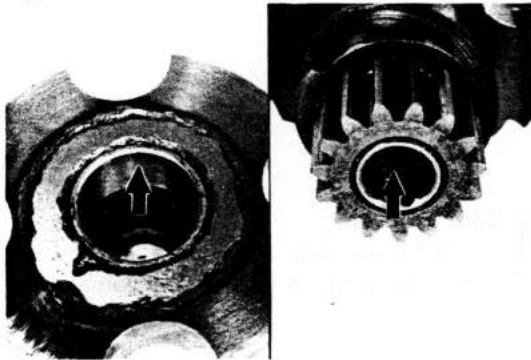

2. Check the bushing for wear or damage.

Fig. 10-67

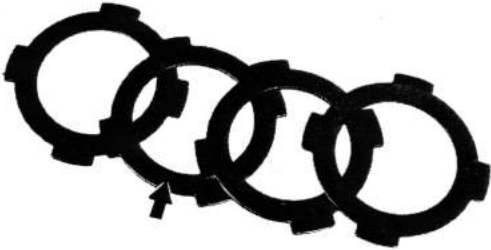

Clutch Outer Disc

Check for burning, wear or damage.

Fig. 10-68

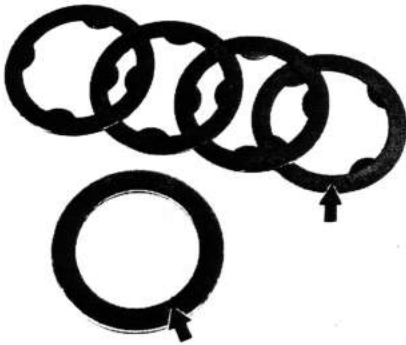

Clutch Inner Disc & Plate

Check for burning, wear or damage.

Fig. 10-69



Winch Drum

Check for damage.

Fig. 10-70



Shift Lever

Check for damage.
Check the bushing for wear or damage.

ris.

le as

Fig. 10-71

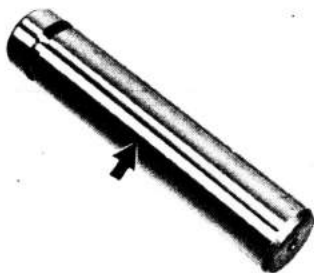

No.2 Counter Shaft

Check for wear or damage.

Fig. 10-72



No.3 Counter Gear

Check for wear or damage.

Fig. 10-73

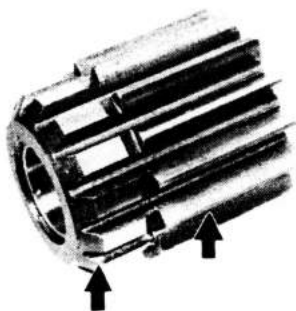

No.4 Counter Gear

1. Check for wear or damage.

Fig. 10-74

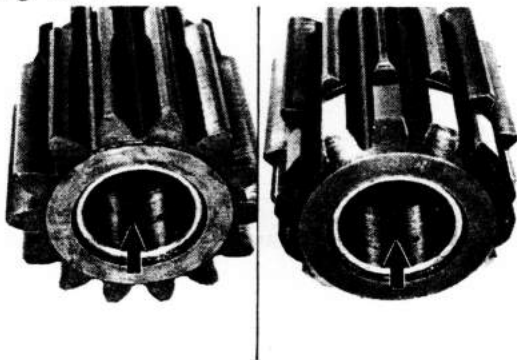

2. Check the bushing for wear or damage.

Fig. 10-75

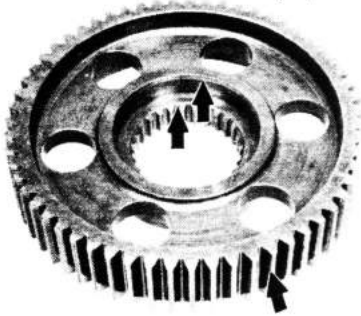

Output Gear

Check for wear or damage.

Fig. 10-76

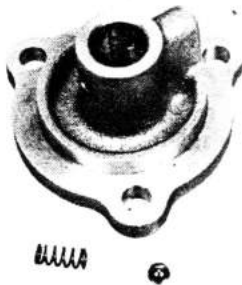

Shift Shaft Retainer, Spring & Ball

Check for wear or damage.

Fig. 10-77

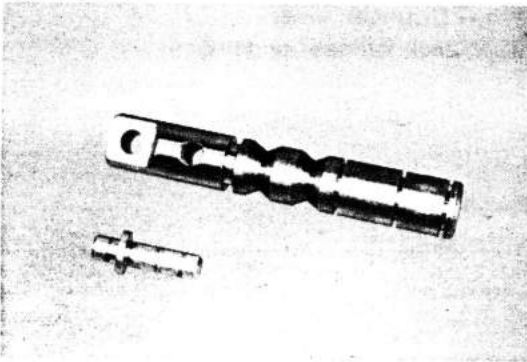

Sleeve Shift Shaft & Pin

Check for wear or damage.

Fig. 10-78



Inner Hub

Check for wear or damage.

Fig. 10-79

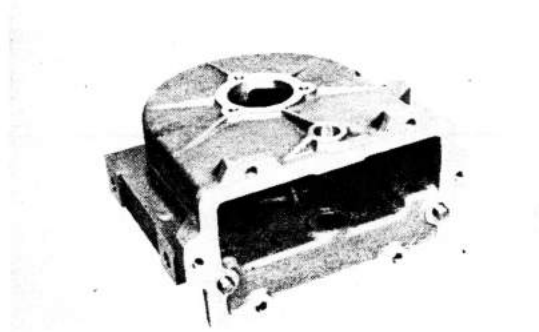

Winch Case

1. Check for wear or damage.

Fig. 10-80

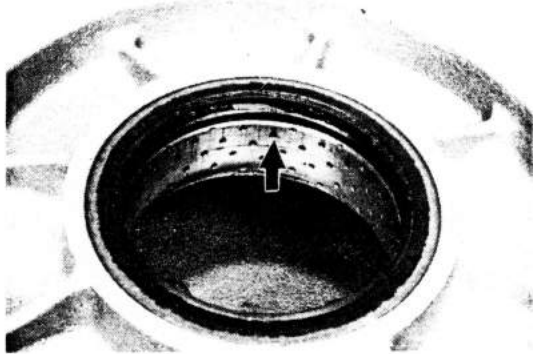

2. Check the bushing for wear or damage.

Fig. 10-81

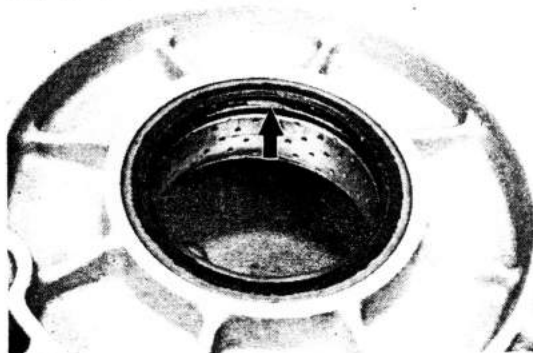

3. Check the oil seal for wear or damage.

Fig. 10-82

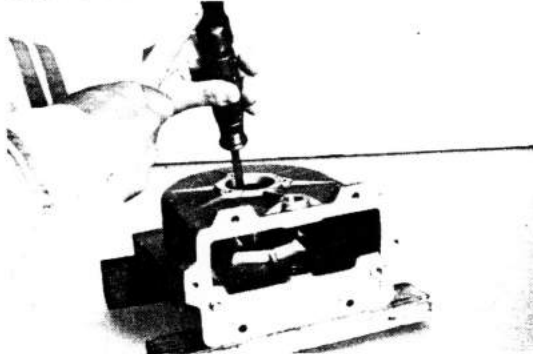

Replace The Oil Seal

1. Remove the oil seal.

Fig. 10-83

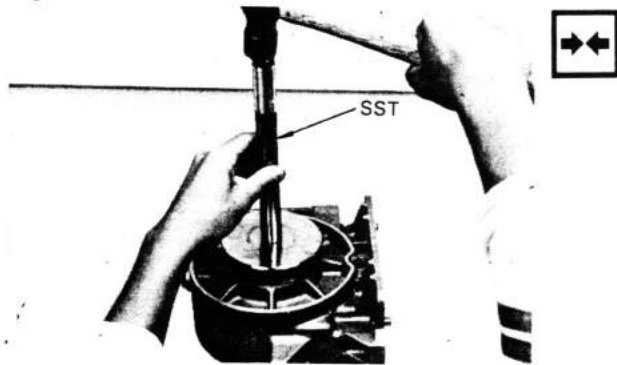

2. Install a new oil seal with SST.
SST [09550-55010]

Fig. 10-84



3. Coat the oil seal with MP grease.

ASSEMBLY

1. Assemble the case cover in the numerical order shown in the figure.

Fig. 10-85

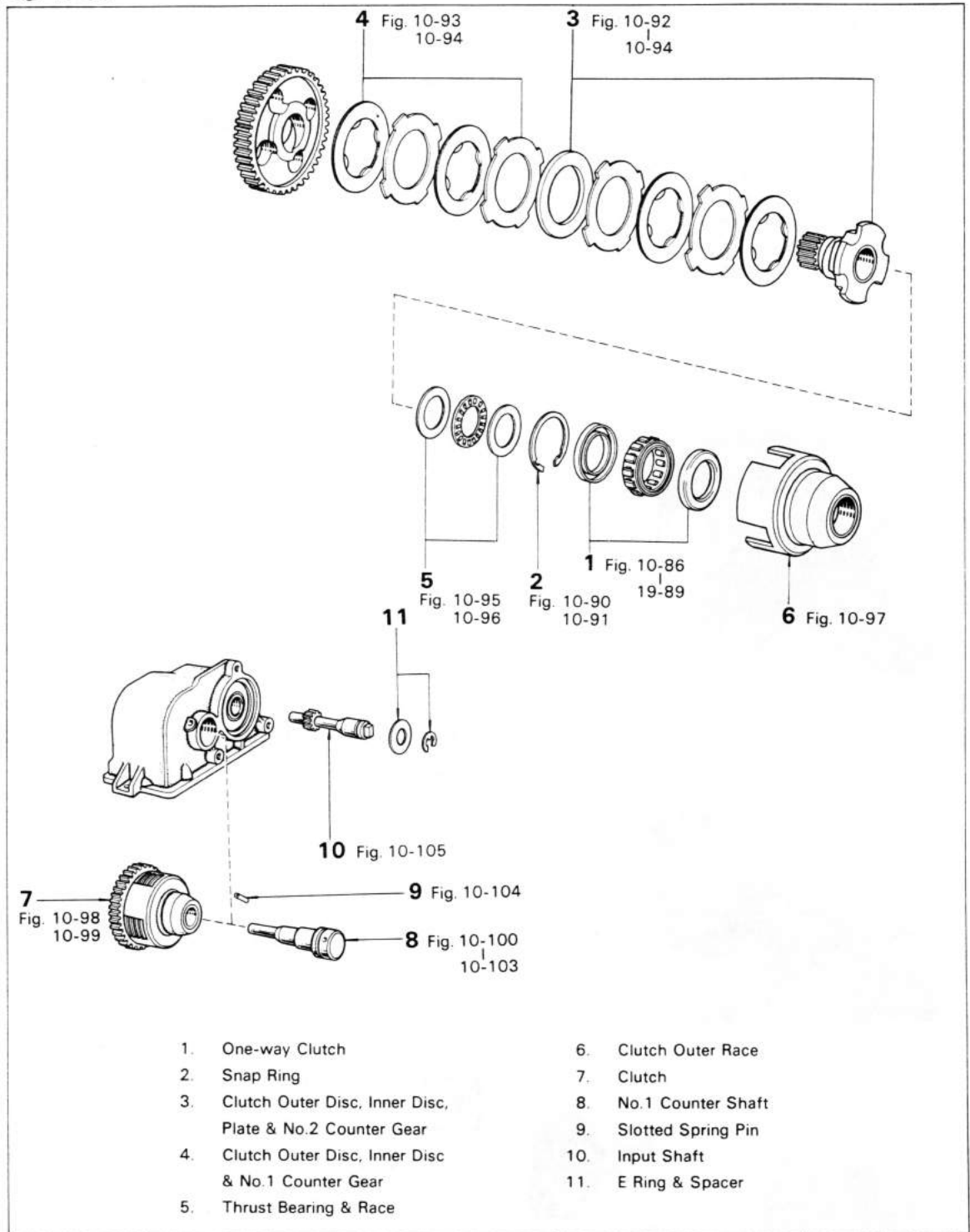

cardiagn.com

Fig. 10-86

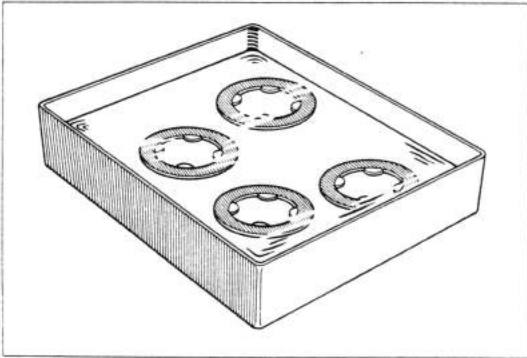

Before assembling new inner discs, soak them in automatic transmission fluid, for at least 30 minutes.

Fluid ATF Type F

Fig. 10-87



Coat the outer race bushing with MP grease.

Fig. 10-88

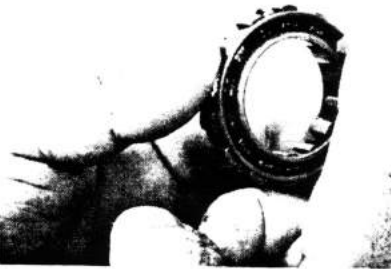

Coat the one-way clutch with MP grease.

Fig. 10-89

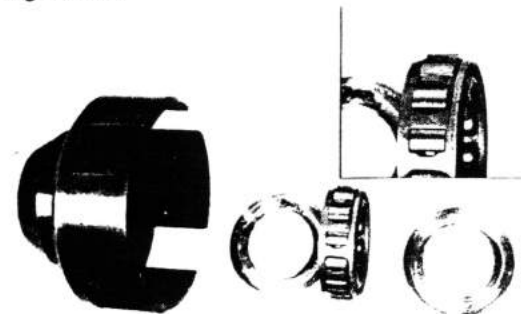

Assemble the one-way clutch as shown in the figure

Fig. 10-90



Install the snap ring.

— Note —

Confirm that the snap ring is securely installed.

Fig. 10-91



Check the one-way clutch.

Fig. 10-92

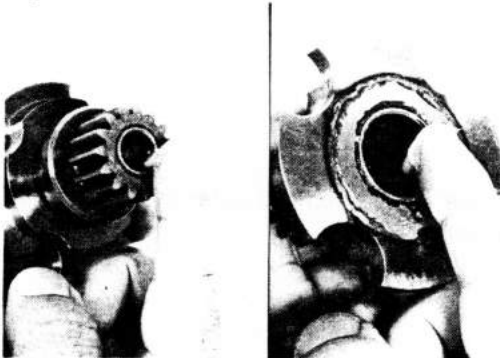

Coat the No.2 counter gear with MP grease.

Fig. 10-93

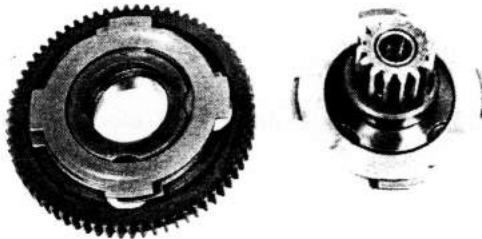

Align the notch and tab and assemble the clutch disc to the counter gear.

Fig. 10-94

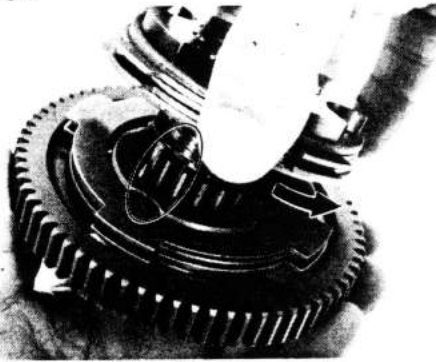

Hold the clutch disc and plate by hand and assemble the No.1 and No.2 counter gears as shown in the figure.

Fig. 10-95

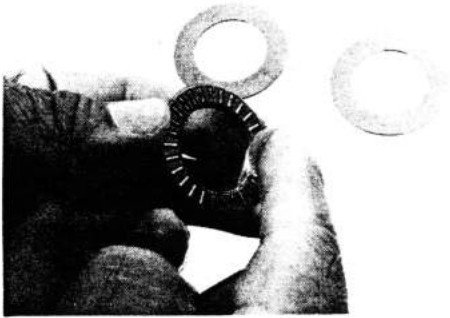

Coat the thrust bearing and race with MP grease.

Fig. 10-96



Before assembling the outer race, set up the disc flukes.

Fig. 10-97



Turn the No.2 counter gear clockwise and lock.

Fig. 10-98

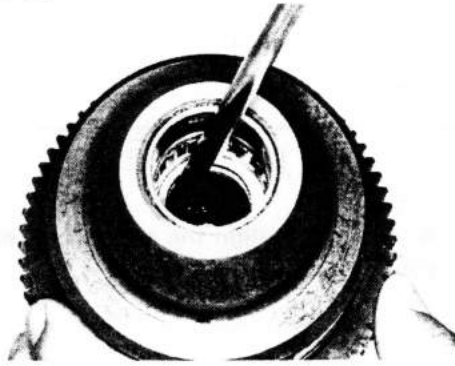

Confirm that the thrust bearing and race are aligned in the center.

Fig. 10-99



Coat the bearing parts of the case cover with MP grease.

Fig. 10-100

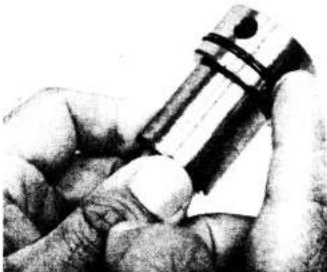

Install a new O ring and coat with MP grease.

Fig. 10-101



Hold No.1 counter gear by hand and push in No.1 counter shaft

Fig. 10-102

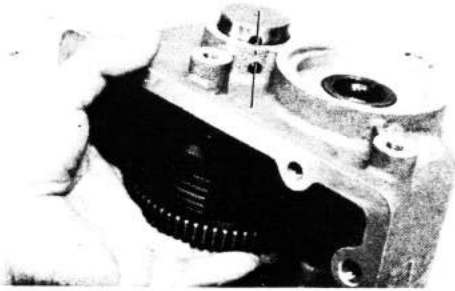

— Note —

At this time, align the case cover hole and counter shaft hole.

Fig. 10-103

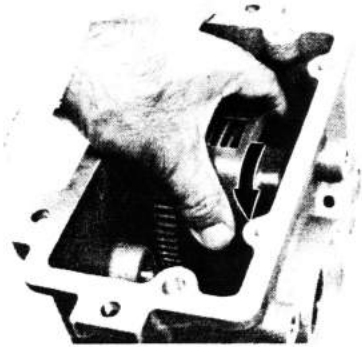

After assembling No.1 counter shaft if the holes are not aligned, rotate the outer race counterclockwise and align the holes.

Fig. 10-104



Tap in the slotted spring pin with a pin punch.

Fig. 10-105

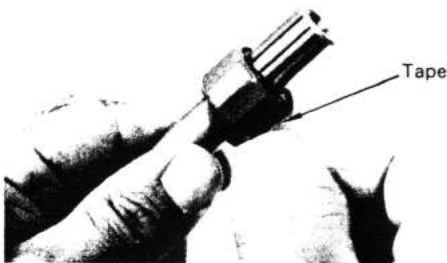

Before assembling the input shaft, wrap the gear with tape.

2. Assemble the winch case in the numerical order shown in the figure.

Fig. 10-106

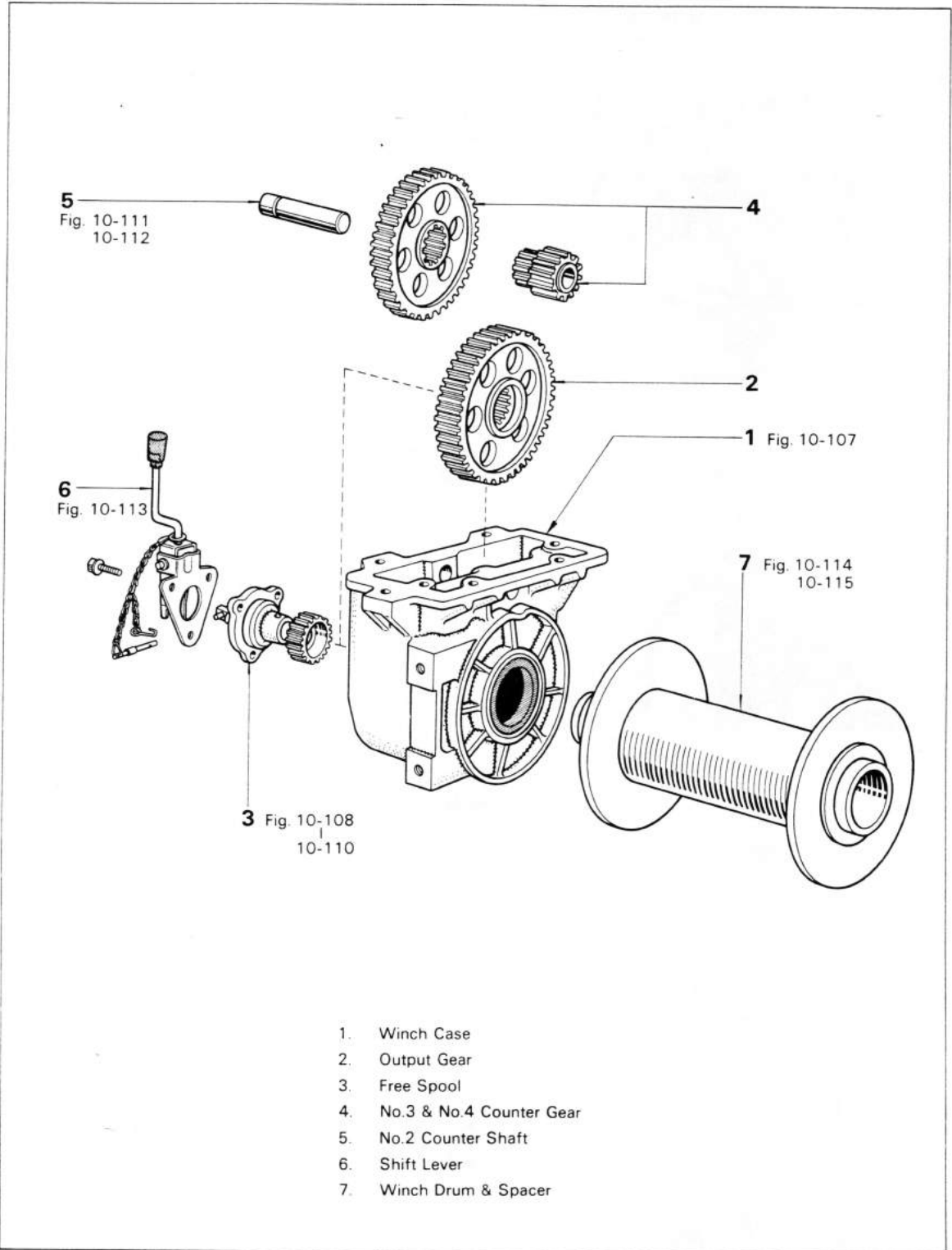

1. Winch Case
2. Output Gear
3. Free Spool
4. No.3 & No.4 Counter Gear
5. No.2 Counter Shaft
6. Shift Lever
7. Winch Drum & Spacer

Fig. 10-107

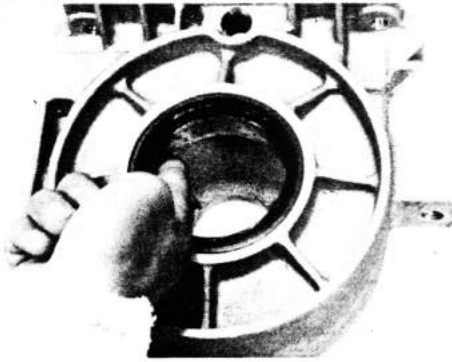

Coat the winch case bushing with MP grease.

Fig. 10-108



Coat the sleeve shift shaft and O ring with MP grease.

Fig. 10-109

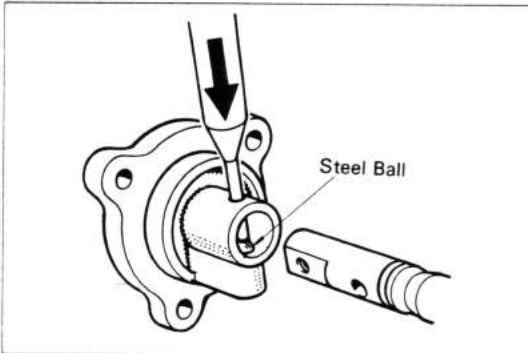

Install the shift shaft retainer and steel ball.

Fig. 10-110

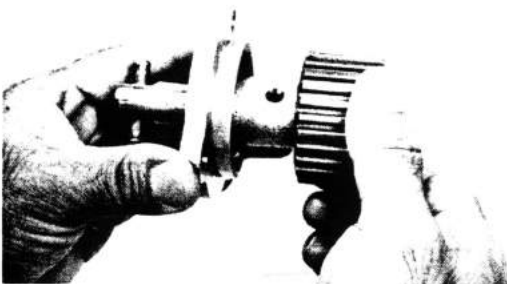

Make sure that the position of the shift shaft retainer is as shown in the figure.

Fig. 10-111



Coat No.2 counter shaft and a new O ring with Mp grease.

Fig. 10-112



Tap in No.2 counter shaft.

Fig. 10-113

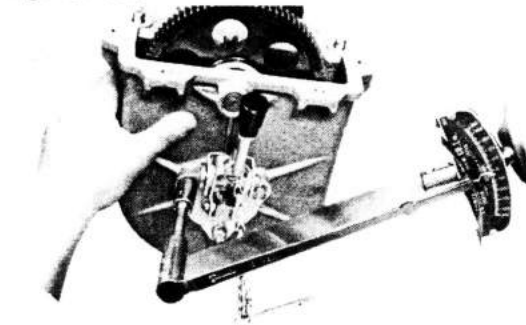

Tighten the shift lever support.

**Tightening torque: 1.5 – 2.2 kg-m
(11 – 15 ft-lb)**

Fig. 10-114



Coat the spacer with MP grease.

Fig. 10-115

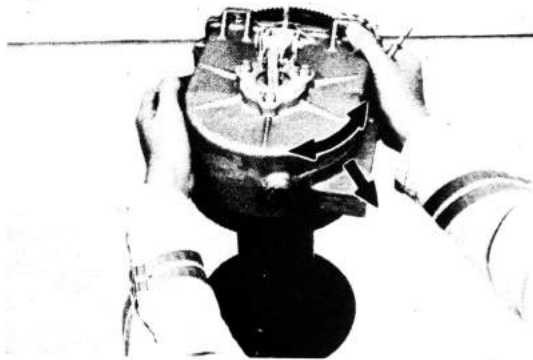

Install the winch drum.

3. Assemble the winch in the numerical order shown in the figure.

Fig. 10-116

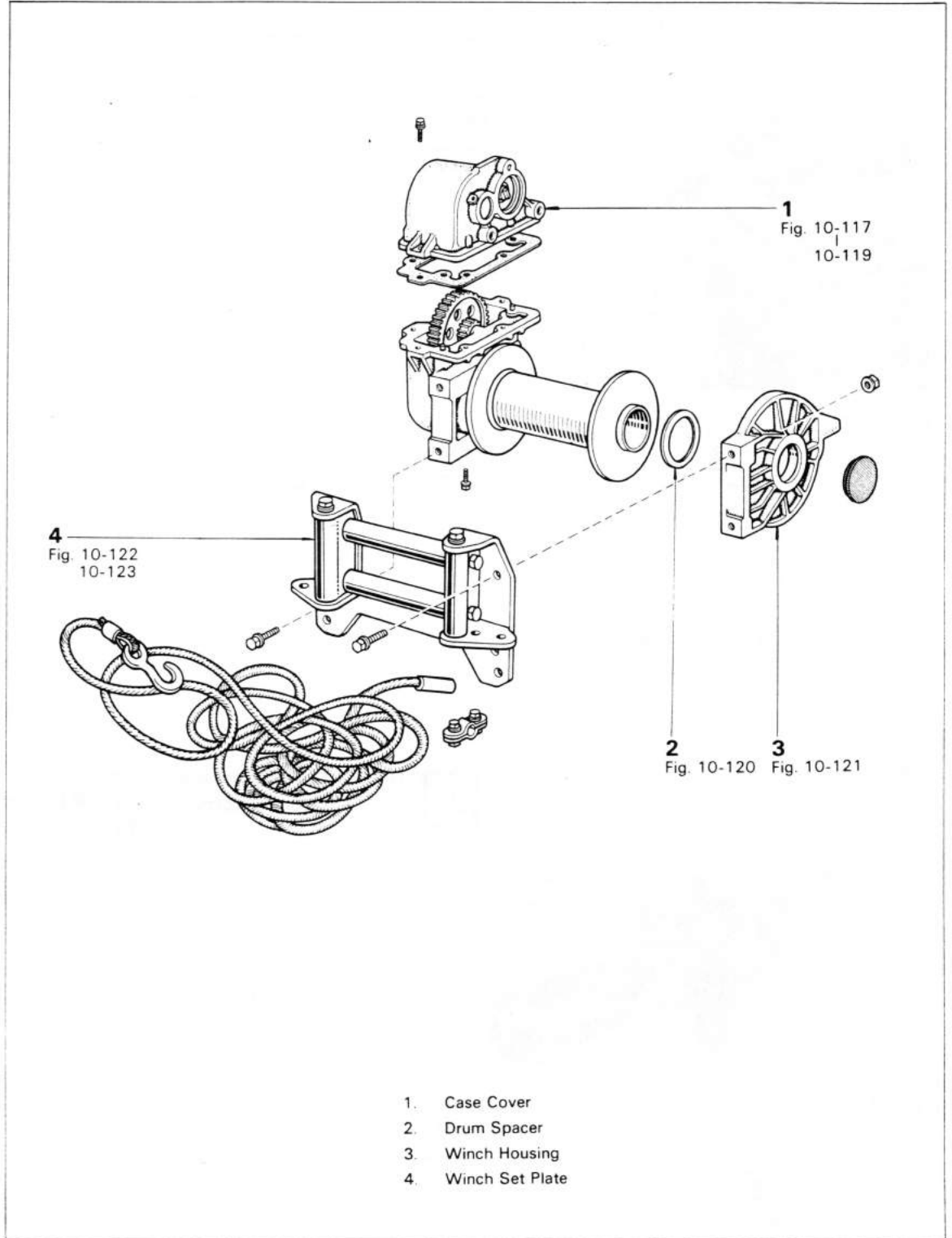
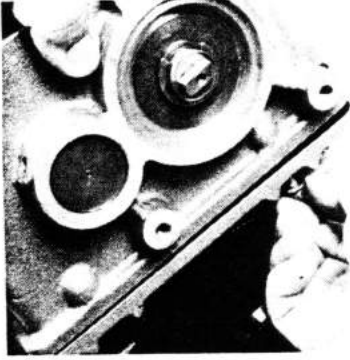
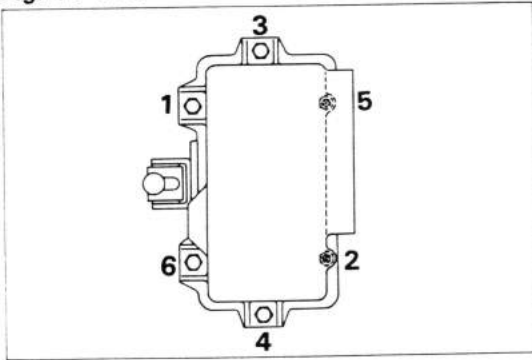

Fig. 10-117



First, install the bolt in the place shown in the figure.

Fig. 10-118



Tighten each bolt a little at a time, in the sequence shown in the figure.

Fig. 10-119

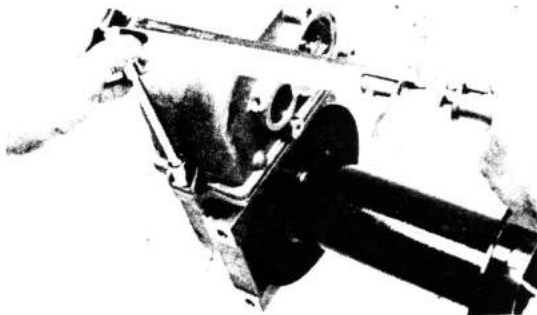

Tighten the bolts to specified torque.

**Tightening torque: 1.5 – 2.2 kg-m
(11 – 15 ft-lb)**

Fig. 10-120



Coat the drum spacer with MP grease.

Fig. 10-121

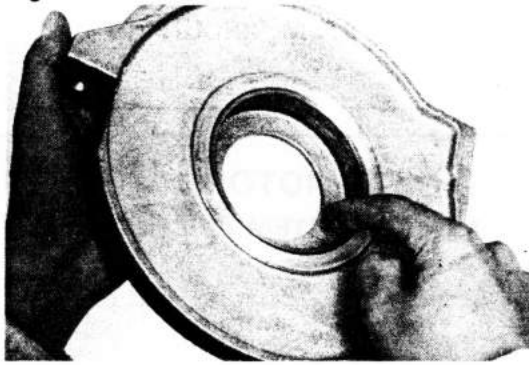

Coat the bushing of the housing with MP grease.

Fig. 10-122

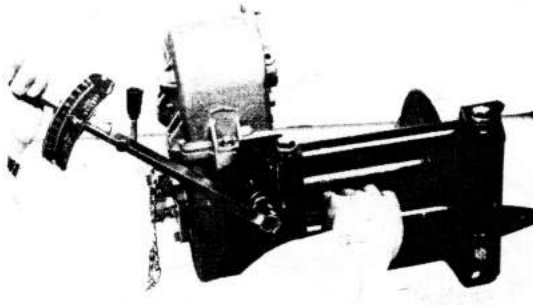

Tighten the bolts to specified torque.

**Tightening torque: 5.0 – 8.0 kg-m
(37 – 57 ft-lb)**

Fig. 10-123

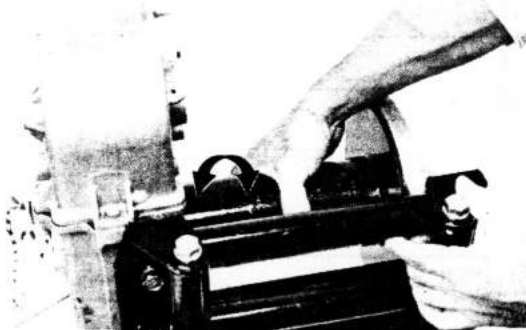

Check that the drum rotates smoothly.

WINCH MOTOR MOTOR SYSTEM CIRCUIT

Fig. 10-124

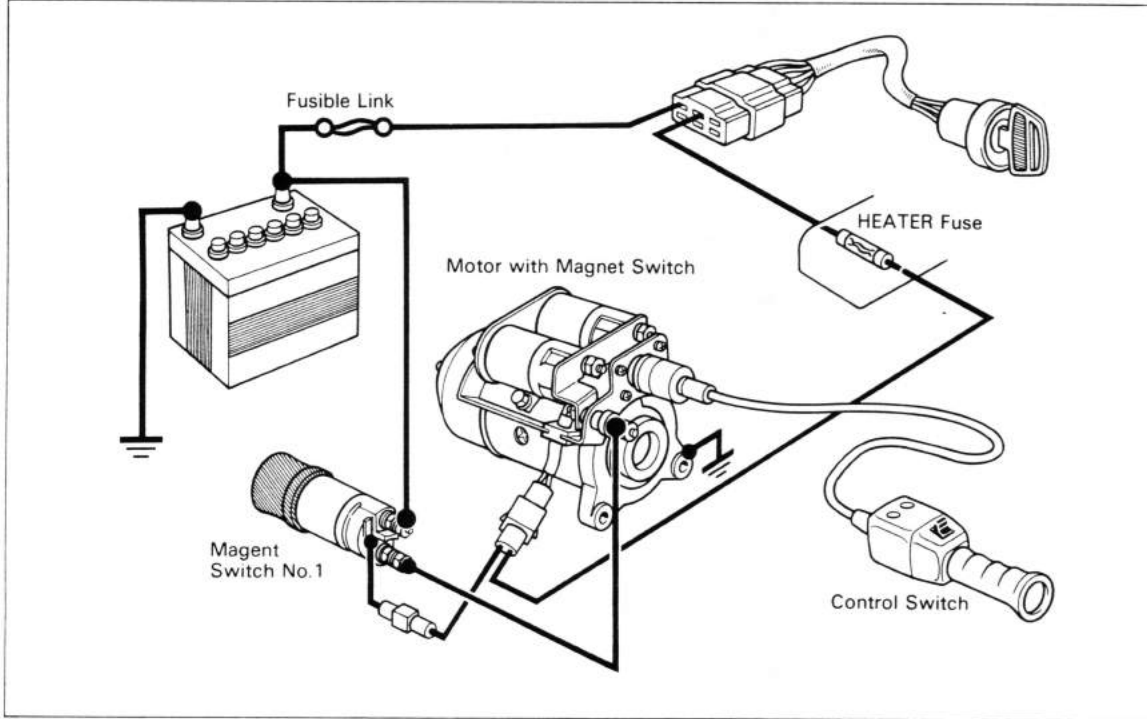
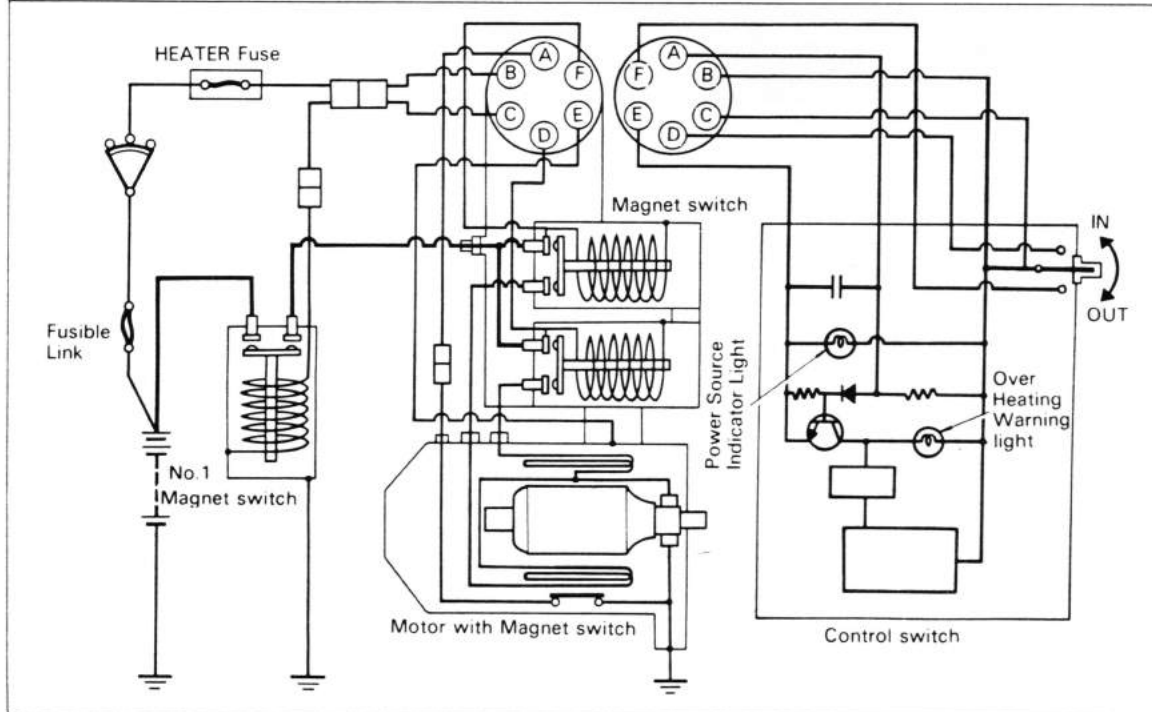

Fig. 10-125



DISASSEMBLY

1. Disassemble the parts in the numerical order shown in the figure.

Fig. 10-126

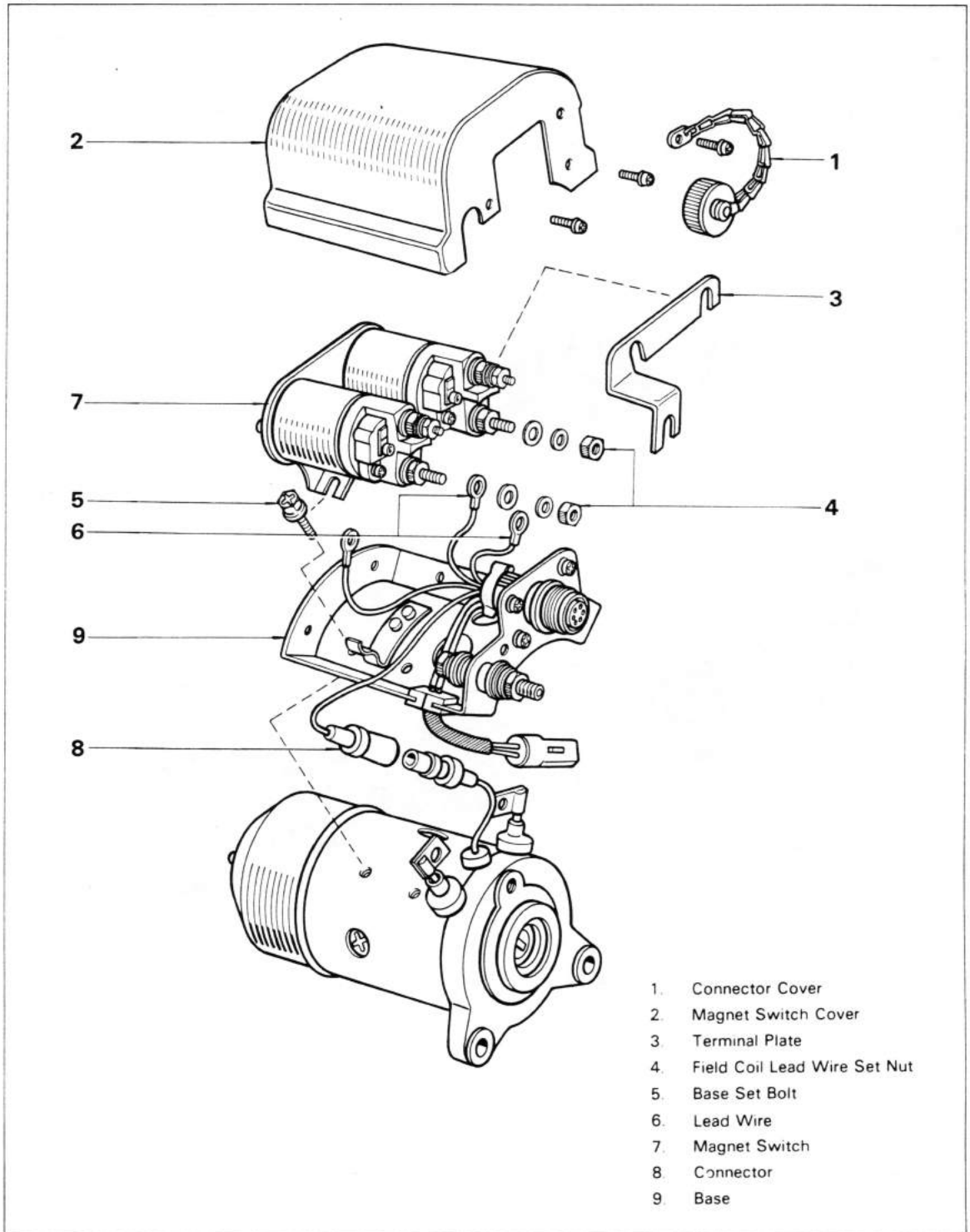

2. Disassemble the parts in the numerical order shown in the figure.

Fig. 10-127

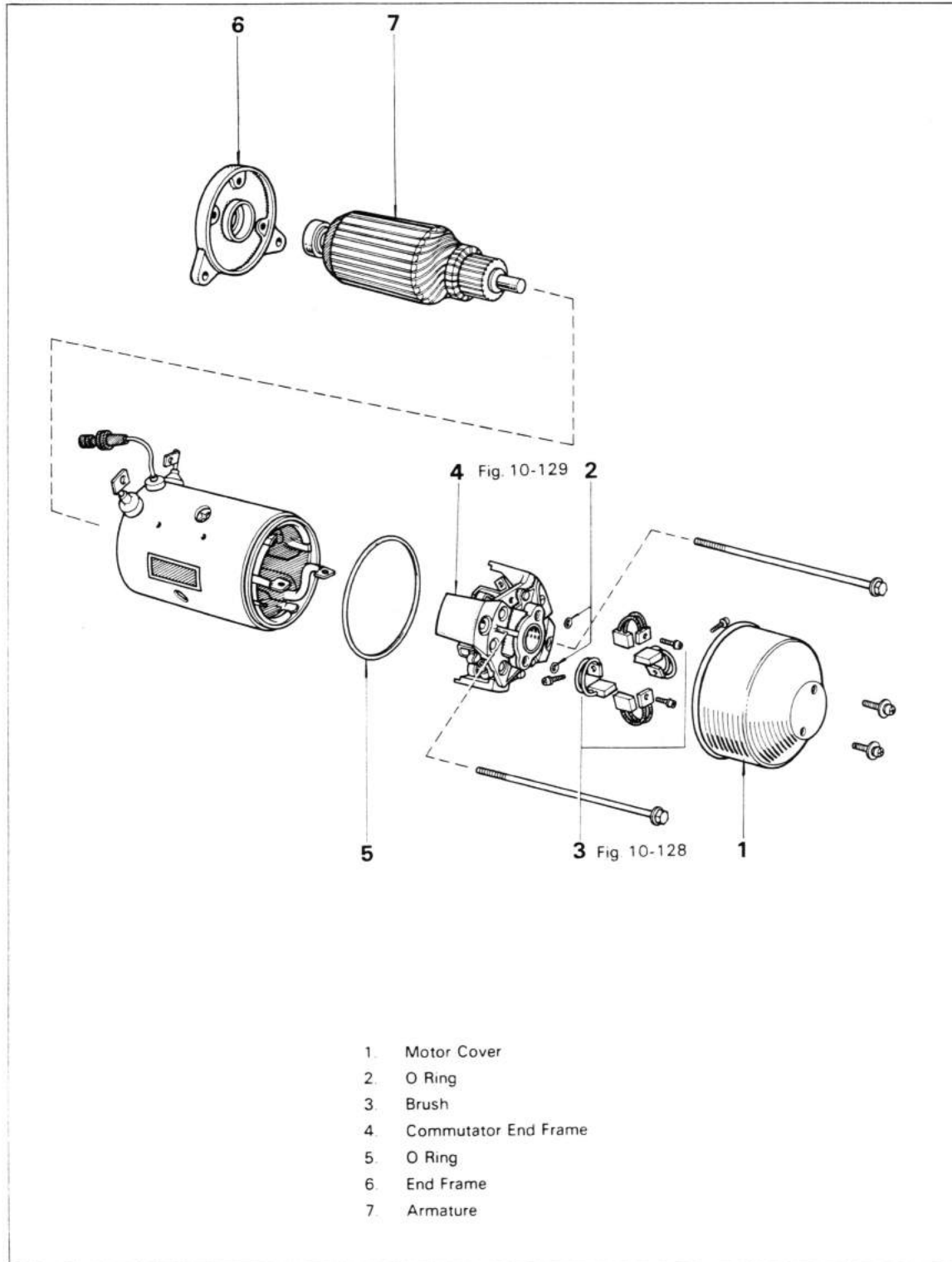
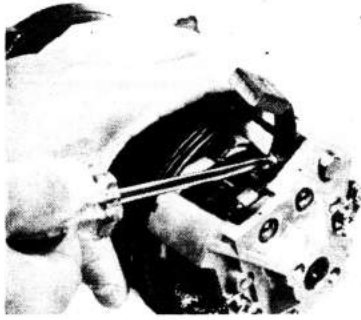
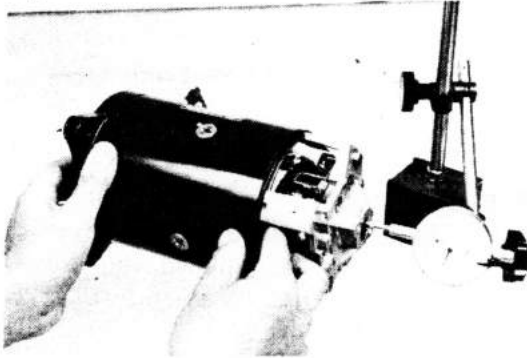

Fig. 10-128



Take off the brushes and remove the screw.

Fig. 10-129



Measure the armature shaft thrust clearance.

Thrust clearance:

0.05 – 0.50 mm

(0.0020 – 0.0197 in.)

Thrust washer thickness:

1.6 mm

(0.063 in.)

Fig. 10-130

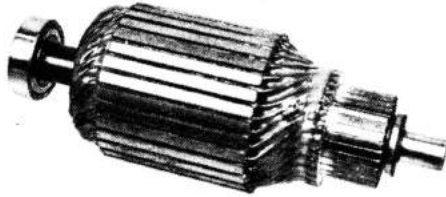
**INSPECTION & REPAIR****Armature Shaft**

Check for wear or damage.

Fig. 10-131

**Bearing**

1. Check to see that there is no drag on the bearing when it is turned with force.

Fig. 10-132

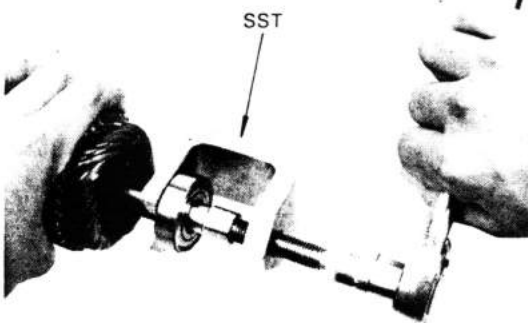

2. Replace the bearing.

- (1) Remove the bearing with SST.
SST [09611-12010]

Fig. 10-133



- (2) Install the bearing with a press.

Fig. 10-134



- (3) Check the bearing condition.

Fig. 10-135

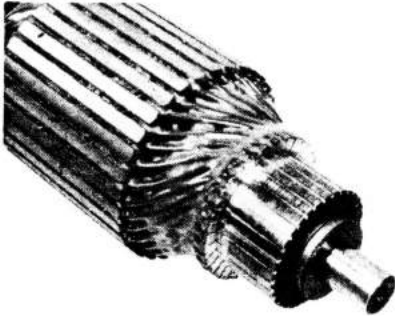

Commutator

Check for following items and repair or replace.

1. Dirty or burnt surface.
Correct by sandpaper if necessary.

Fig. 10-136

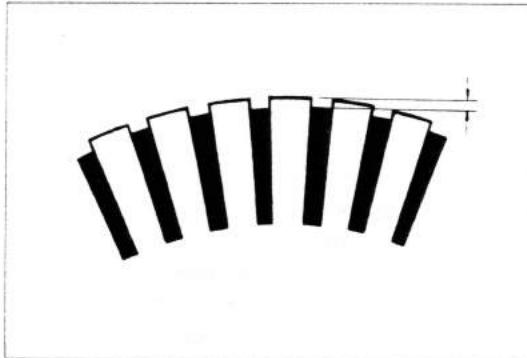

2. Depth of segment mica.

Mica depth:

STD	0.7 mm
	(0.028 in.)
Limit	0.3 mm
	(0.012 in.)

Fig. 10-137

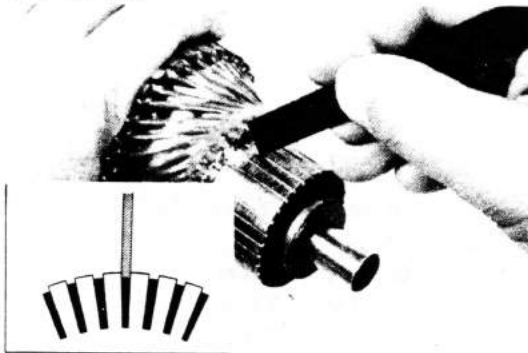

3. Correct with a hacksaw blade.
After correcting, eliminate chips using sandpaper.

Fig. 10-138

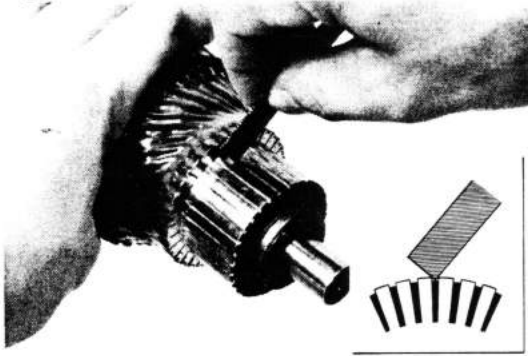

4. Smooth out the edge with a hacksaw blade.

Fig. 10-139



5. Use #400 sandpaper.

Fig. 10-140

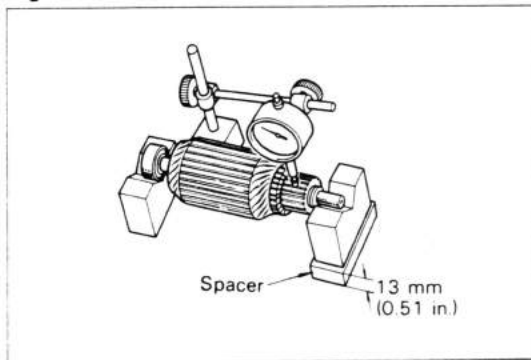

6. Measure the runout.

Runout:	
STD	0.05 mm (0.0020 in.)
Limit	0.20 mm (0.0079 in.)

Fig. 10-141



7. Surface wear: If below the limit, replace armature.

Outer diameter:	
STD	43 mm (1.69 in.)
Limit	41 mm (1.61 in.)

Fig. 10-142

**Armature Coil**

1. Ground test

Check commutator and armature coil core. If there is continuity, armature is grounded and must be replaced.

Fig. 10-143



2. Open circuit test

Check for continuity between the segments.

If there is no continuity at any test point, there is an open circuit and armature must be replaced.

Fig. 10-144

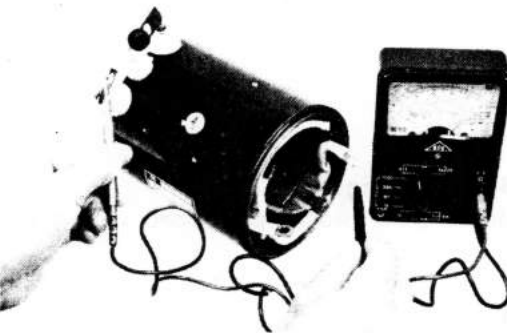
**Field Coil**

1. Open-circuit test

Check for continuity between lead wire and field coil brush soldered connection. If there is no continuity, there is an open-circuit in field coil and it should be replaced.

Fig. 10-145

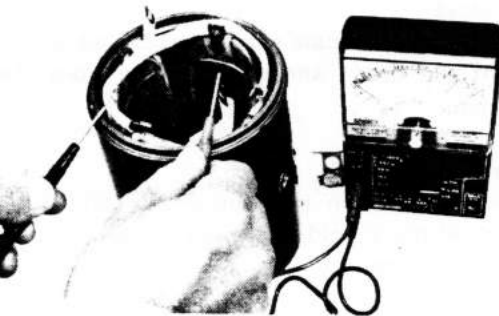

2. Ground test

Check for continuity between field coil end and field frame.

If there is continuity, repair or replace field coil.

Fig. 10-146

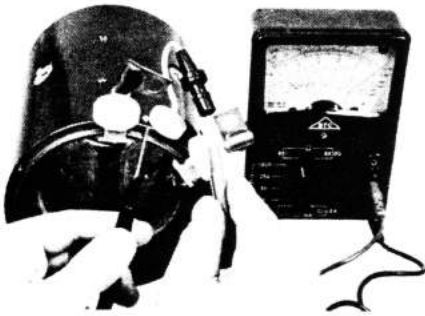
**Thermo Switch**

Check for continuity shown in the figure.

Fig. 10-147

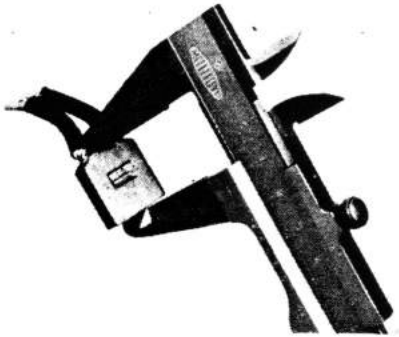
**Brush**

Measure brush length and replace if below limit.

Brush length:

STD	22 mm (0.87 in.)
Limit	15 mm (0.59 in.)

Fig. 10-148

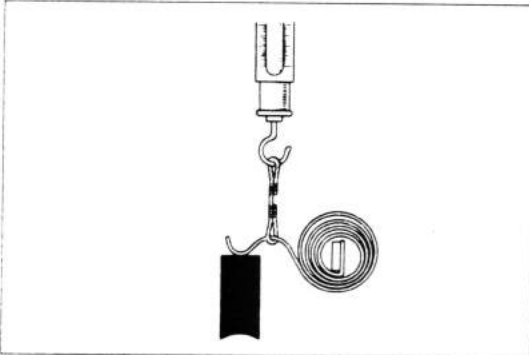
**Brush Spring**

Measure the brush spring load with a pull scale.

If the reading is below standard, replace the spring.

Tension:	3.2 – 4.0 kg (7.1 – 8.8 lb)
-----------------	--

– Note –

Take the pull scale reading at the very instant the brush spring separates from the brush.

Fig. 10-149

**Brush Holder**

Check insulation between (–) brush holder and (+) brush holder. Repair or replace if continuity is indicated.

Fig. 10-150

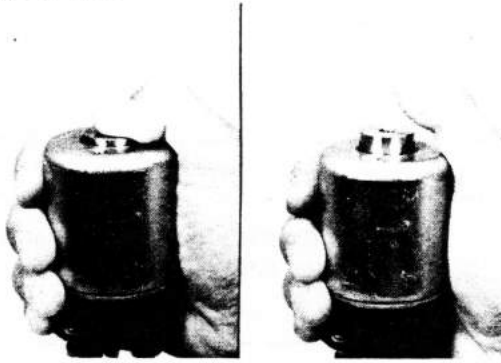
**Magnetic Switch**

1. Push in plunger and release it. Plunger should return quickly to its original position.

Fig. 10-151



2. Check for continuity.

Fig. 10-152



3. Check for no continuity.

Fig. 10-153

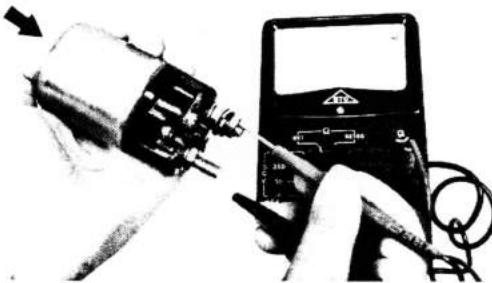

4. Push in the plunger until it stops. Check for continuity.

— Note —

Perform a switch operation test after assembling it to the motor.

ASSEMBLY

1. Assemble the parts in the numerical order shown in the figure.

Fig. 10-154

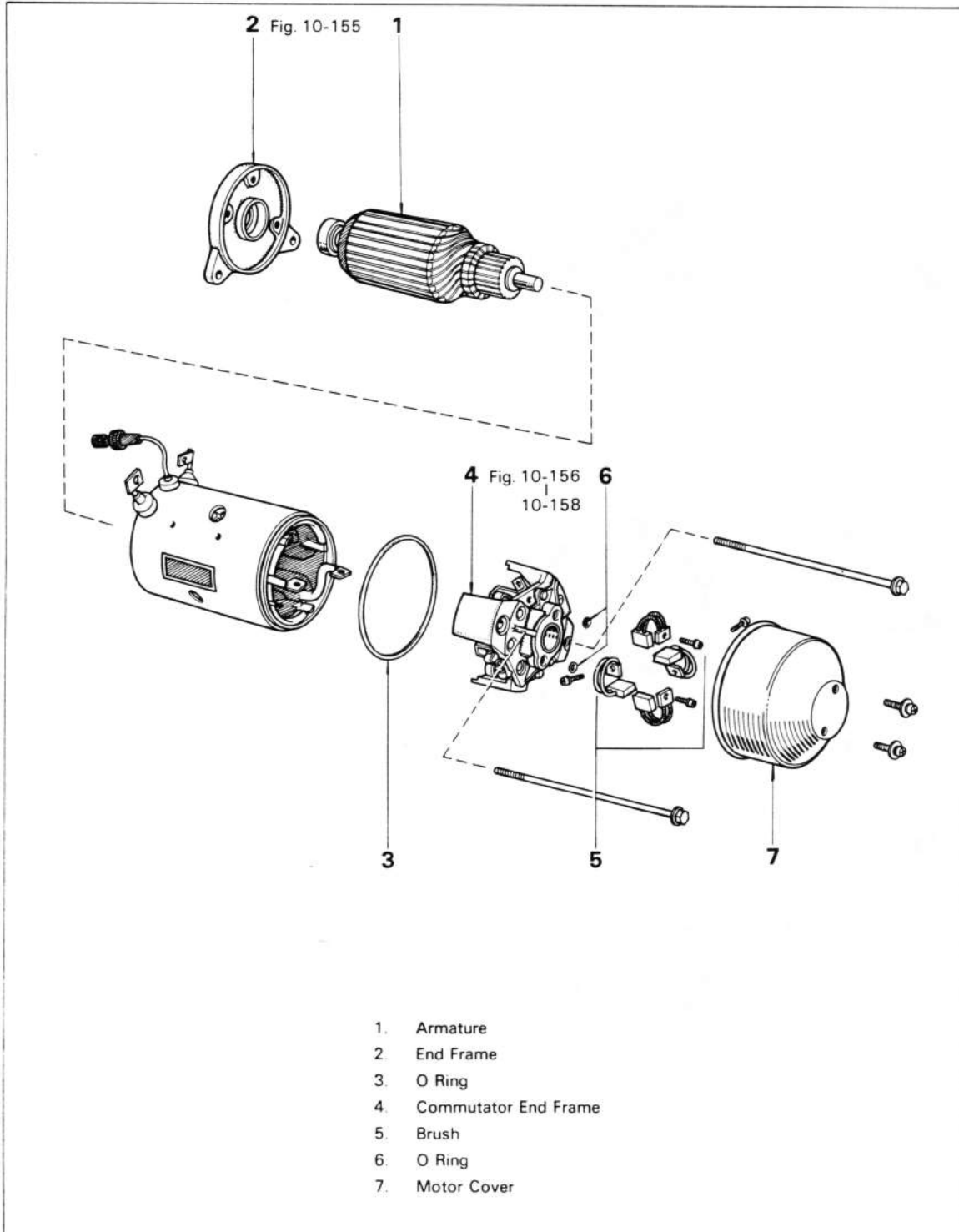
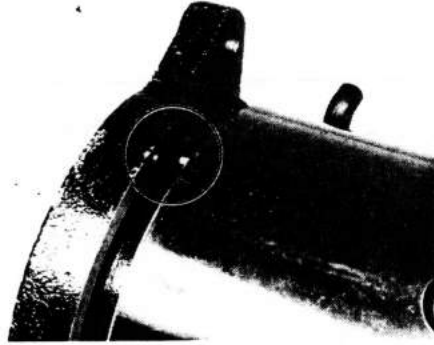
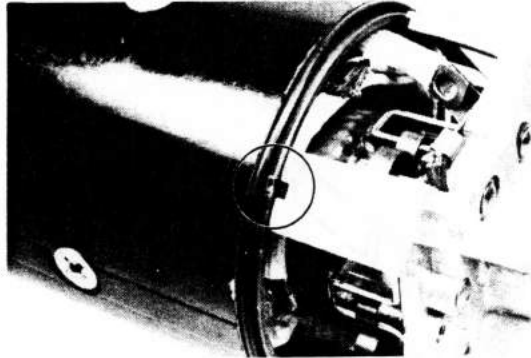

Fig. 10-155



Align yoke dowel with center bearing hole.

Fig. 10-156



Align yoke edge dowel with groove on commutator end frame.

Fig. 10-157



Apply retaining compound to the bolts.

— Note —
Use Lock-Tight.

Fig. 10-158

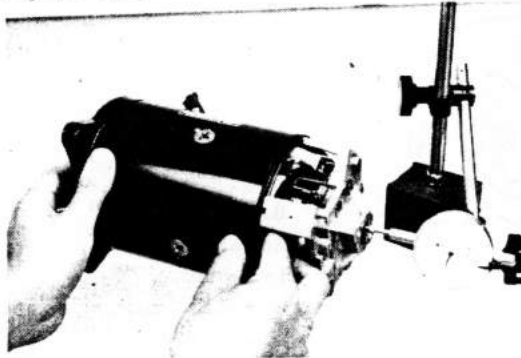

Recheck armature shaft thrust clearance.

Thrust clearance:

0.05 – 0.50 mm

(0.0020 – 0.0197 in.)

Thrust washer thickness:

1.6 mm

(0.063 in.)

2. Assemble the parts in the numerical order shown in the figure.

Fig. 10-159

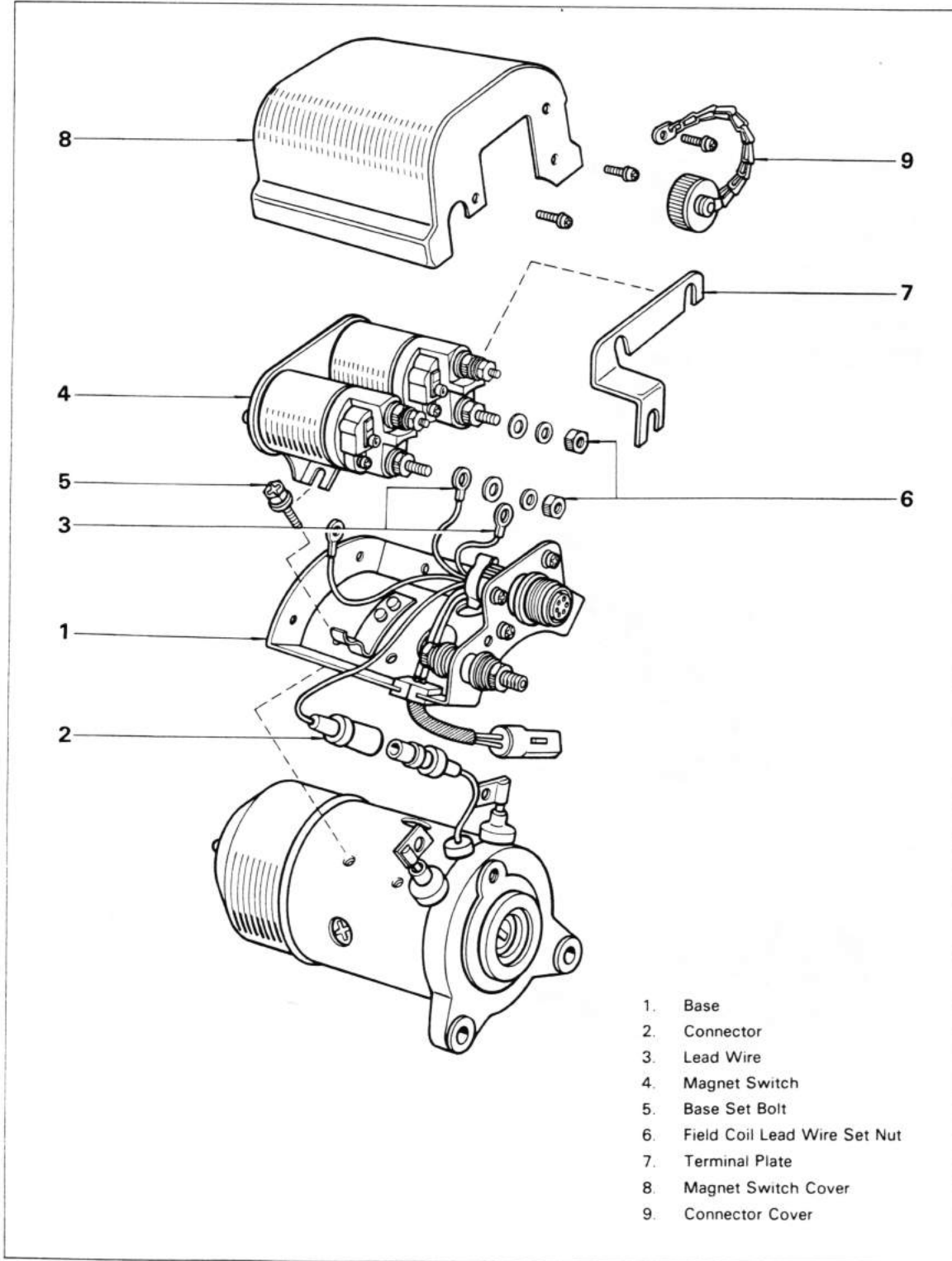

INSTALLATION

Install the parts in the numerical order shown in the figure.

Fig. 10-160

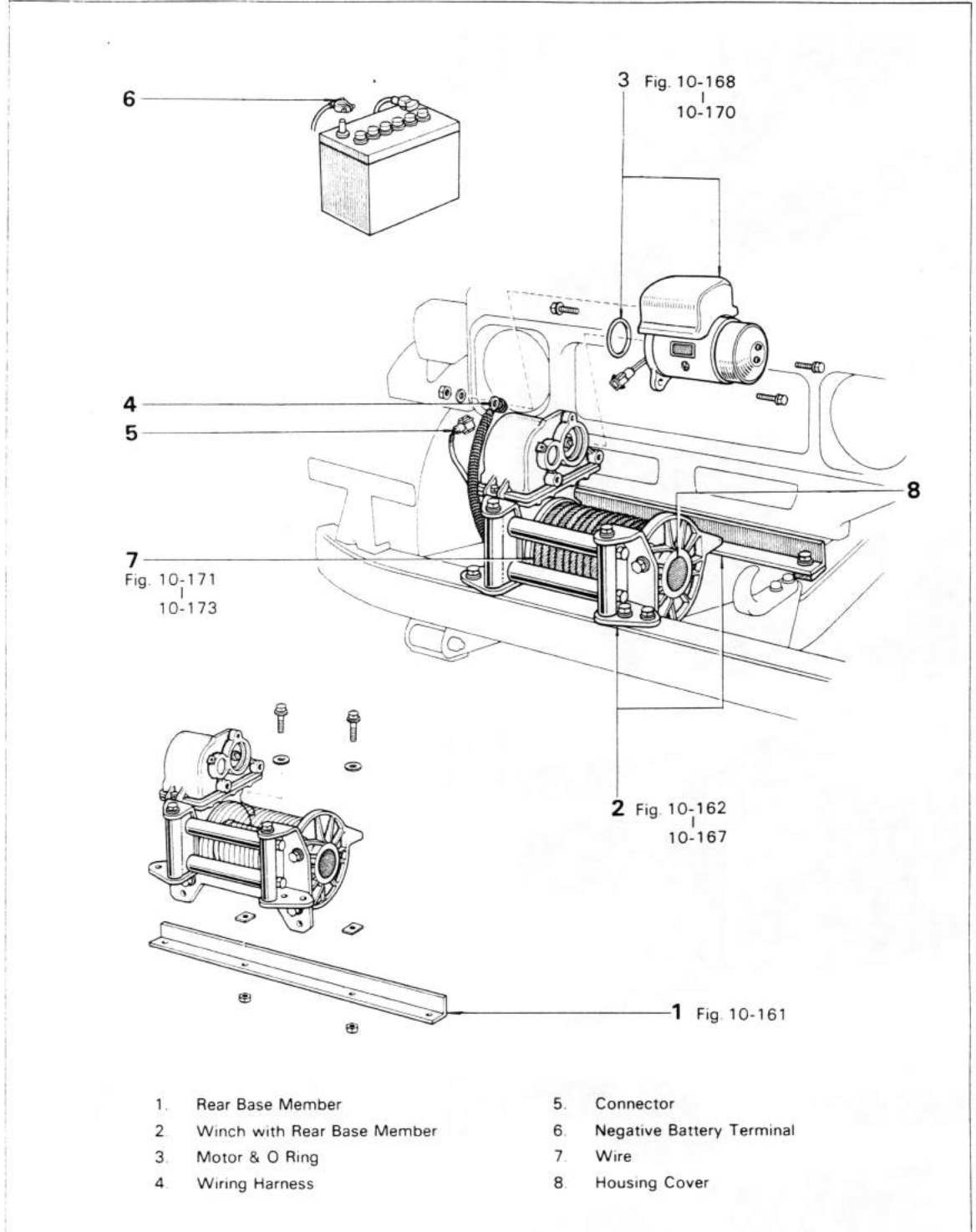

- | | |
|--------------------------------|------------------------------|
| 1. Rear Base Member | 5. Connector |
| 2. Winch with Rear Base Member | 6. Negative Battery Terminal |
| 3. Motor & O Ring | 7. Wire |
| 4. Wiring Harness | 8. Housing Cover |

cardiagn.com

Fig. 10-161

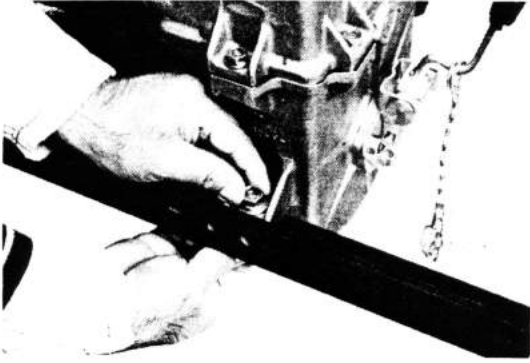

Temporarily install the rear base member.

Fig. 10-162

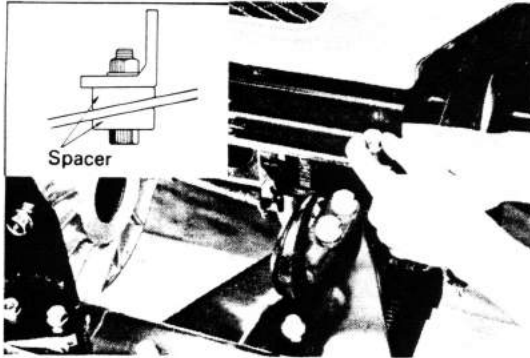

Install the winch mounted on the rear base member through a spacer to the frame.

Fig. 10-163

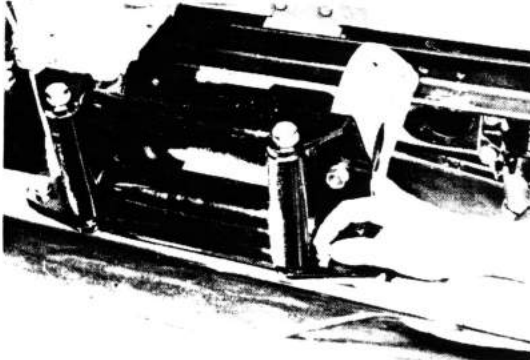

Install the winch front mounting bolt and temporarily tighten.

Fig. 10-164

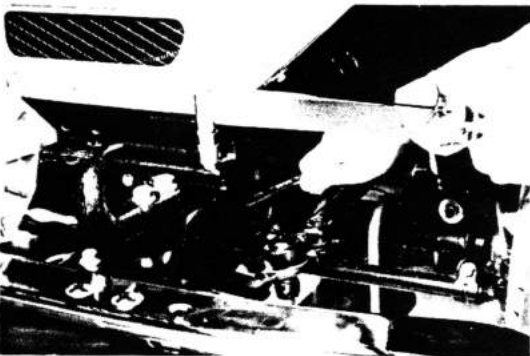

Tighten the rear base member mounting bolts.

**Tightening torque: 5.0 – 8.0 kg-m
(37 – 57 ft-lb)**

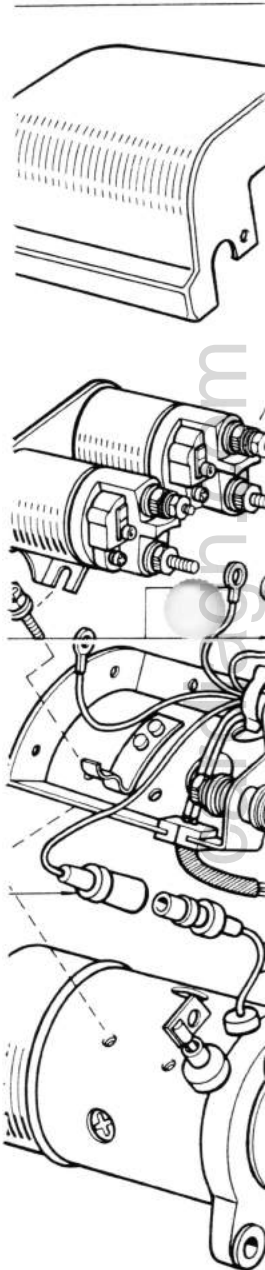
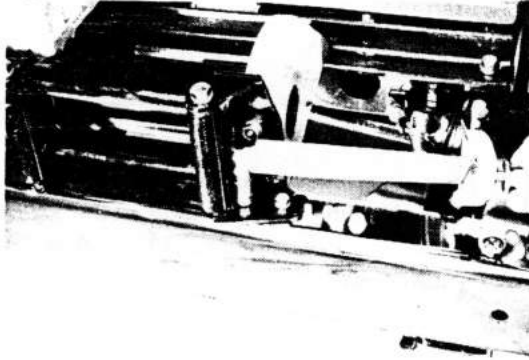

Fig. 10-165



Tighten the winch front mounting bolts.

**Tightening torque: 3.0 – 4.5 kg-m
(22 – 32 ft-lb)**

Fig. 10-166

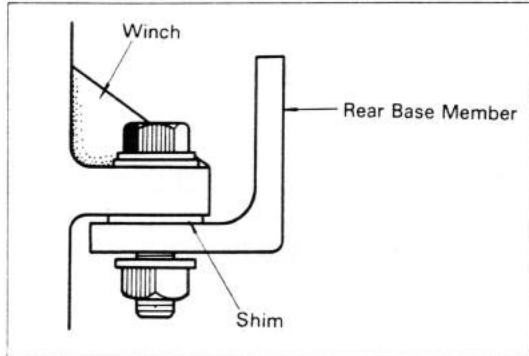

Check the clearance between the rear base member and winch rear mount.

If there is clearance, insert shims.

Fig. 10-167

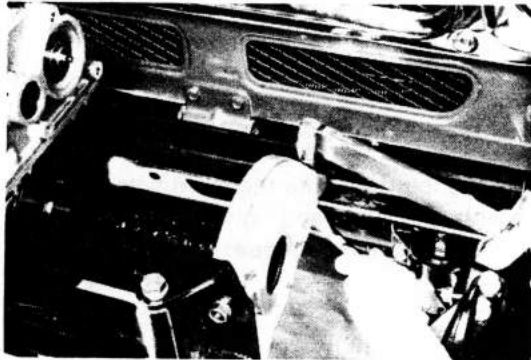

Tighten the winch rear mounting bolts.

**Tightening torque: 3.0 – 4.5 kg-m
(22 – 32 ft-lb)**

Fig. 10-168

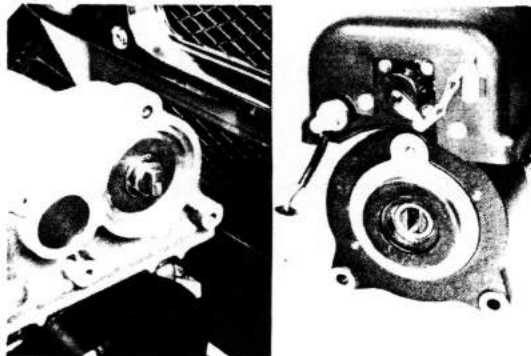

Align the protrusion and groove, and install the motor.

Fig. 10-169

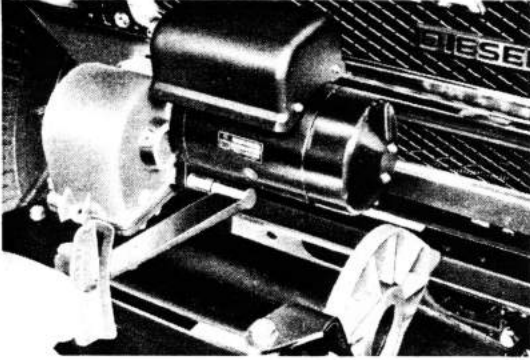

Tighten the motor mounting bolts.

**Tightening torque: 1.5 – 2.0 kg-m
(11 – 14 ft-lb)**

Fig. 10-170

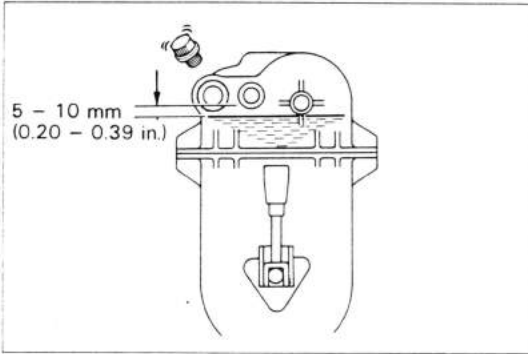

Fill with about 2 liters of automatic transmission fluid.

Fluid ATF Type F

Fig. 10-171



Insert the cable into the drum hole, install the cable lock plate and tighten the bolts.

**Tightening torque: 1.5 – 2.0 kg-m
(11 – 14 ft-lb)**

Fig. 10-172



Shift the lever to the lock position.