

## FRONT AXLE & FRONT SUSPENSION

DESCRIPTION .....	5 - 1
TROUBLE SHOOTING .....	5 - 2
STEERING KNUCKLE & AXLE SHAFT .....	5 - 5
Ball joint type .....	5 - 5
Removal & disassembly .....	5 - 7
Inspection & repair .....	5 - 8
Adjustment .....	5 -10
Assembly & installation .....	5 -16
Birfield constant velocity joint type .....	5 -19
Removal & disassembly .....	5 -21
Inspection & repair .....	5 -23
Adjustment .....	5 -26
Assembly & installation .....	5 -26
DIFFERENTIAL .....	5 -29
Removal .....	5 -29
Installation .....	5 -30
FRONT SUSPENSION .....	5 -31
Removal .....	5 -32
Inspection & repair .....	5 -32
Installation .....	5 -32

## DESCRIPTION

The front axle shaft is of the full-floating, banjo housing, hypoid gear hotchkiss drive type.

The front suspension consists mainly of the leaf springs and the double acting telescopic type hydraulic shock absorbers.

The leaf springs and the shock absorbers are mounted through the rubber bushings.

The front axle shaft is full-floating in which the load and the drive force of the front wheels are completely carried by the axle housing, and the front axle shafts serve only to transmit the driving torque.

The joints of the axle shafts are provided with two types; one is the ball joint type, and the other is the birfield constant velocity joint type.

The axle shaft and the joint have the construction as illustrated in figure 5-2 and figure 5-22.

The action of the axle shaft joints at the steering knuckles permit delivery of power to the wheels when they are turned from the straight ahead position.

The method of drive is the hotchkiss type in which the driving force is transmitted to the frame through the leaf springs, and has the advantages of simple construction, easy manufacturing and maintenance.

The differential is placed off center to the right side in order to provide more road clearance and to allow the front propeller shaft to be in the with the transfer case. The differential is almost identical with that used on the rear axle. As the differential gear are of hypoid type, it requires the use of hypoid gear lubricant.

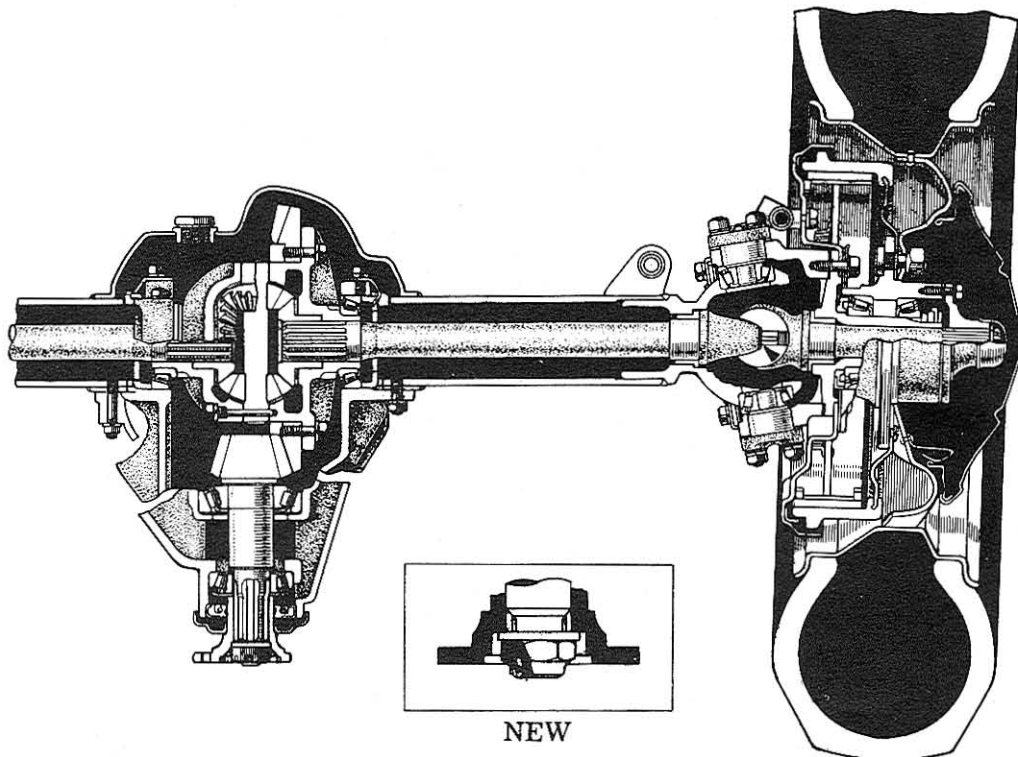

Fig. 5-1 Cross Section of Front Axle (Ball Joint Type)

G2437

## 5-2 FRONT AXLE & FRONT SUSPENSION - Description

### Specifications:

Axle housing type	Banjo
Front axle shaft type	Full-floating
Front ball joint type	Ball joint
	Birfield constant velocity (optional)

### Differential:

Gear type	Hoypod	
Reduction ratio	3.7	4.11
Number of gear teeth:		
Drive pinion	10	9
Ring gear	37	37
Differential pinion	10	10
Differential side gear	16	16
Lubricant capacity	Hypoid gear oil SAE 90 - 2.5 liters (2.6 US qts., 2.2 Imp qts)	

### Front Spring

	FJ40(L), FJ43(L), FJ45(L)	FJ55(L)
Number of leaf springs	7	7
Span of spring at no load	1106 mm (43.5")	1100 mm (43.3")
Width	70 mm (2.76")	70 mm (2.76")
Thickness	6 mm (0.24")	6 mm (0.24")
Camber at no load	128.6 mm (5.06")	128 mm (5.04")
Spring constant	5.2 kg/mm (291 lb/in)	5.18 kg/mm (290 lb/in)

### Front Shock Absorber

	FJ40(L), FJ43(L), FJ45(L)	FJ55(L)
Stroke	180 mm (7.09")	200 mm (7.87")
Maximum length	468 mm (18.43")	495 mm (19.49")
Minimum length	288 mm (11.34")	295 mm (11.61")
Damping force at 0.3m/sec:		
In Compression	25 kg (55.1 lb)	55 kg (121.3 lb)
In Rebound	72 kg (158.8 lb)	160 kg (352.8 lb)

## TROUBLE SHOOTING

The trouble shooting of the front axle covered in this part includes only those symptoms caused by the front wheel misalignment and the defective front axle parts.

The trouble shooting of the differential is excluded since the troubles are almost common to those of the rear axle differential.

### Symptoms & Probable Causes

### Remedies

#### 1. Hard steering

Jack up the front end and check by turning the steering wheel with two front wheels off the ground.

If the steering is easy, check the tire inflation.

If the steering is hard, check the steering system.

For hard steering, disconnect the pitman arm from the sector shaft, then operate the steering wheel.

If the steering is easy, check the steering linkage.

If the steering is hard, check the steering gear housing assembly.

- |                                                         |                                      |
|---------------------------------------------------------|--------------------------------------|
| a. Low tire pressure                                    | Inflate the tires to proper pressure |
| b. Incorrect front end alignment                        | Correct alignment                    |
| c. Lack of lubrication                                  | Lubricate                            |
| d. Defective knuckle bearing/s                          | Replace bearing/s                    |
| e. Improper knuckle bearing pre-load                    | Adjust and correct pre-load          |
| f. Steering gear housing improperly adjusted or damaged | Repair or replace                    |
| g. Bent steering main shaft                             | Replace main shaft                   |
| h. Improper adjustment of center arm shaft              | Repair center arm shaft              |
| i. Defective universal joint/s of intermediate shaft    | Repair or replace universal joint/s  |

2. Steering shimmy

This is caused by excessive play in the steering wheel or wobbles in the front wheels.

The phenomenon becomes evident on rough road or at high speed operation. Tests should be made under various conditions.

- |                                                             |                                  |
|-------------------------------------------------------------|----------------------------------|
| a. Tires improperly inflated                                | Inflate tires to proper pressure |
| b. Incorrect front end alignment                            | Adjust alignment                 |
| c. Unbalanced wheel and tire                                | Check and balance wheel and tire |
| d. Loose hub nuts                                           | Tighten                          |
| e. Bent wheel                                               | Repair or replace                |
| f. Damaged, worn or loose wheel bearing                     | Adjust or replace                |
| g. Worn steering knuckle bearing                            | Replace bearing                  |
| h. Steering knuckle bearing pre-load defective              | Adjust pre-load                  |
| i. Play between steering worm and sector shaft is excessive | Adjust play                      |
| j. Loose connection between steering gear housing & frame   | Tighten bolts                    |
| k. Loose connection between steering knuckle & knuckle arm  | Tighten nuts                     |
| l. Loose rod end                                            | Tighten                          |
| m. Loose front axle U-bolts                                 | Tighten                          |
| n. Front spring bracket pin or bushing worn                 | Replace                          |
| o. Worn steering gear                                       | Replace                          |
| p. Excessive wear of rod end                                | Replace rod end                  |
| q. Worn center arm shaft or bushing                         | Replace shaft or bushing         |

3. Steering wheel pulls

While driving, the steering wheel may pull to one side causing difficulty to steer straight ahead.

This phenomenon is due to abnormal front suspension or axle which may have been caused by collision, skidding, or excessive bouncing on rocks or uneven road surface, and may lead to serious accident.

- |                                                     |                                  |
|-----------------------------------------------------|----------------------------------|
| a. Uneven tire inflation                            | Inflate tires to proper pressure |
| b. Improper front end alignment                     | Adjust alignment                 |
| c. Broken or sagging front spring                   | Replace spring                   |
| d. Improperly adjusted brakes                       | Adjust brakes                    |
| e. Defective shock absorber                         | Replace shock absorber           |
| f. Distorted or incorrectly installed suspension    | Check and repair or replace      |
| g. Deformed frame                                   | Repair or replace                |
| h. Deformed rear axle housing                       | Repair or replace                |
| i. Wheel bearing tight or insufficiently lubricated | Adjust or lubricate              |
| j. Improperly adjusted or worn steering gear.       | Adjust or replace                |

4. Shock in steering wheel

When the front wheels bounce on uneven road surface, shocks are transmitted to the steering wheel.

- |                                      |                                |
|--------------------------------------|--------------------------------|
| a. Improper front end alignment      | Adjust alignment               |
| b. Over inflated tires               | Reduce to proper tire pressure |
| c. Improperly adjusted steering gear | Adjust steering gear           |
| d. Defective axle shaft joint        | Repair or replace              |

5. Wheel tramps

- |                                          |                                   |
|------------------------------------------|-----------------------------------|
| a. Over inflated or uneven tire pressure | Inflate to proper tire pressure   |
| b. Unbalanced wheel or tire              | Check and balance wheel with tire |
| c. Defective shock absorber              | Replace                           |
| d. Excessively worn tire                 | Replace tire                      |
| e. Excessively worn rod ends             | Replace rod ends                  |

6. Excessive or abnormal tire wear

- |                                  |                                           |
|----------------------------------|-------------------------------------------|
| a. Improper tire pressure        | Inflate or reduce to proper tire pressure |
| b. Improper front end alignment  | Adjust alignment                          |
| c. Unbalanced wheel with tire    | Check and balance                         |
| d. Excessive wheel bearing play  | Adjust bearing                            |
| e. Wobbling wheel                | Repair or replace wheel                   |
| f. Improper operation of vehicle | Correct operation                         |
| g. Excessive worn rod ends       | Replace rod ends                          |

\* \* \* \* \*

STEERING KNUCKLE & AXLE SHAFT

Ball Joint Type

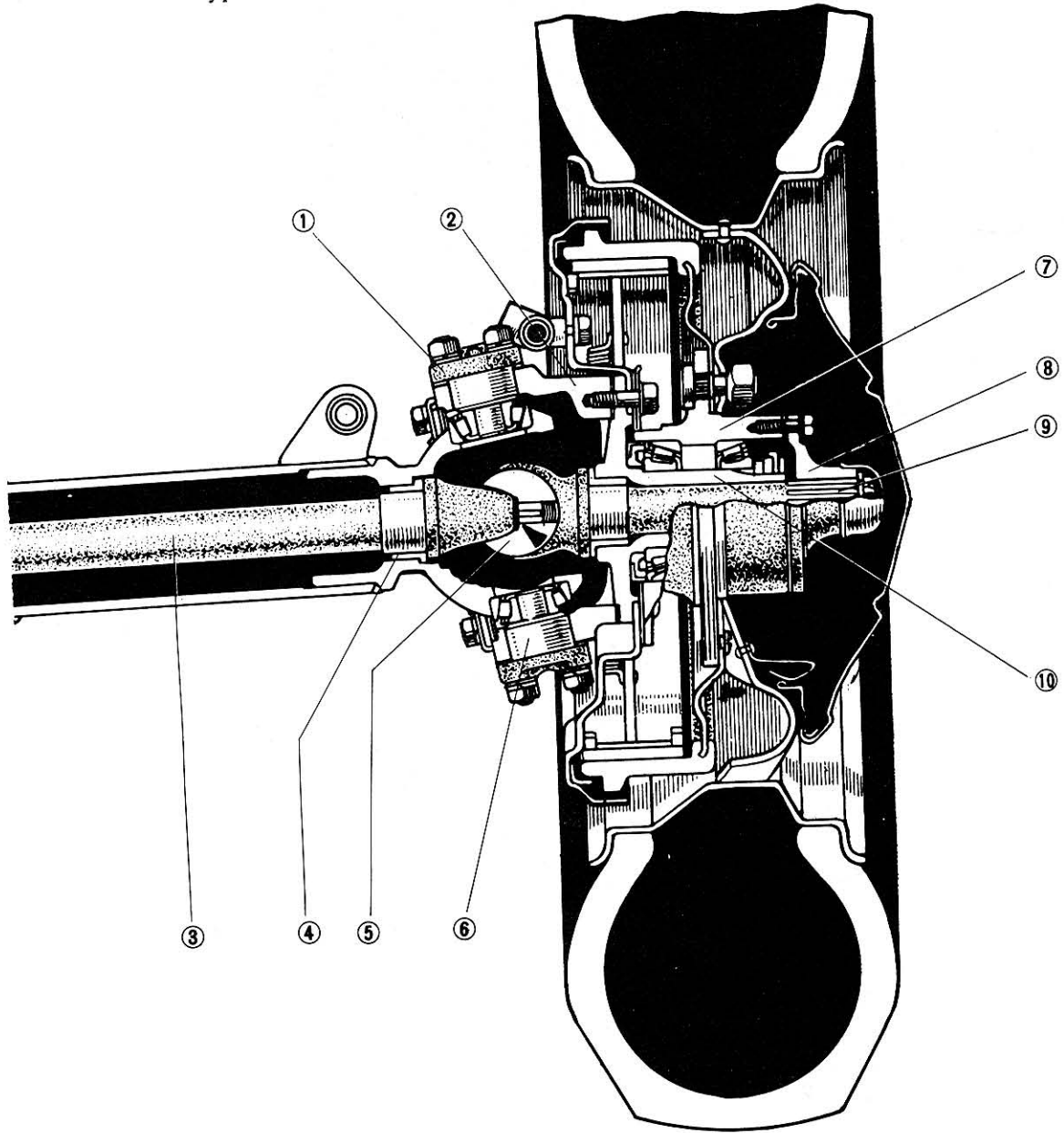

- |                           |                                 |
|---------------------------|---------------------------------|
| 1. Steering knuckle arm   | 6. Steering knuckle bearing cap |
| 2. Steering knuckle       | 7. Front axle hub               |
| 3. Front axle inner shaft | 8. Axle outer shaft flange      |
| 4. Bushing                | 9. Front axle outer shaft       |
| 5. Front drive joint ball | 10. Steering knuckle spindle    |

Fig.5-2 Cross Section View of Steering Knuckle & Axle Shaft G2438

cardiagn.com

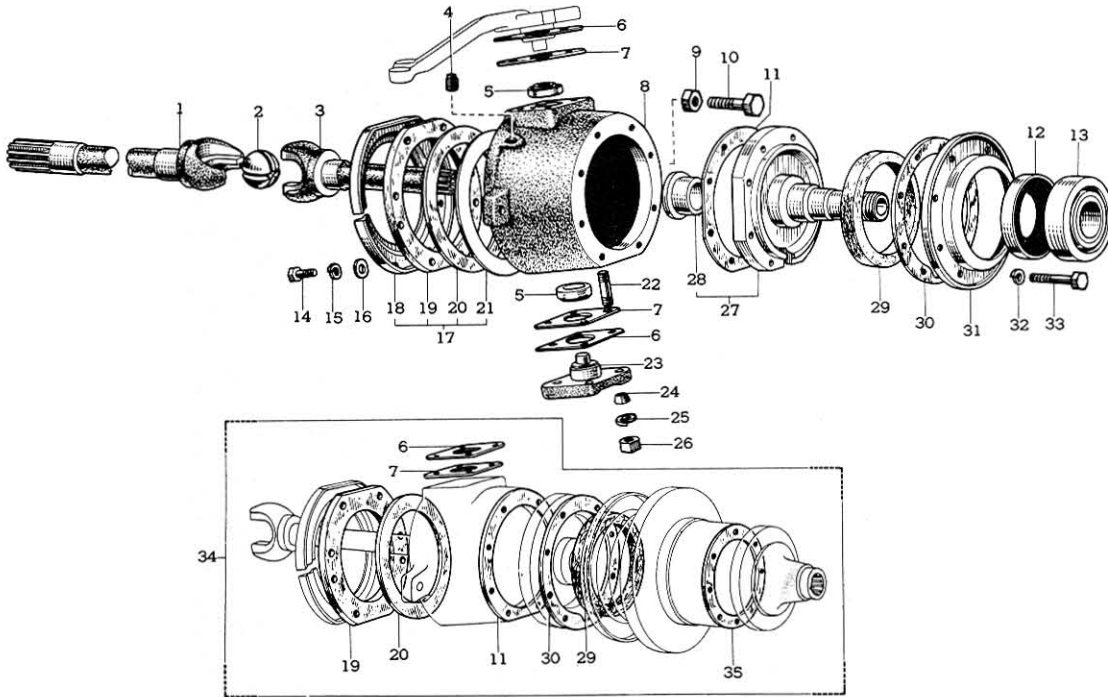

- |                                         |                                    |
|-----------------------------------------|------------------------------------|
| 1. Front axle inner shaft               | 19. Outer oil seal                 |
| 2. Front drive joint ball               | 20. Inner oil seal                 |
| 3. Front axle outer shaft               | 21. Oil seal inner ring            |
| 4. Plug                                 | 22. Stud bolt                      |
| 5. Steering knuckle bearing             | 23. Steering knuckle bearing cap   |
| 6. Steering knuckle adjusting shim No.1 | 24. Dowel                          |
| 7. Steering knuckle adjusting shim No.2 | 25. Lock washer                    |
| 8. Steering knuckle                     | 26. Nut                            |
| 9. Nut                                  | 27. Steering knuckle spindle       |
| 10. Bolt                                | 28. Knuckle spindle bushing        |
| 11. Gasket                              | 29. Dust seal                      |
| 12. Oil seal                            | 30. Oil retainer gasket            |
| 13. Front axle hub inner bearing        | 31. Oil retainer                   |
| 14. Bolt                                | 32. Lock washer                    |
| 15. Lock washer                         | 33. Bolt                           |
| 16. Washer                              | 34. Front axle gasket kit          |
| 17. Steering knuckle oil seal set       | 35. Axle outer shaft flange gasket |
| 18. Oil seal cover                      |                                    |

Fig.5-3 Steering Knuckle & Axle Shaft Components

G2439

Removal & Disassembly

1. Pry off the wheel cap, and loosen the hub nuts.
2. Jack up the front axle housing, and support the housing with suitable stands.
3. Remove the hub nuts and remove the wheel.
4. Plug the brake master cylinder reservoir to prevent brake fluid from running out from the disconnected brake flexible hose.
5. Remove the axle outer shaft flange cap, and then remove the shaft snap ring on the outer shaft.

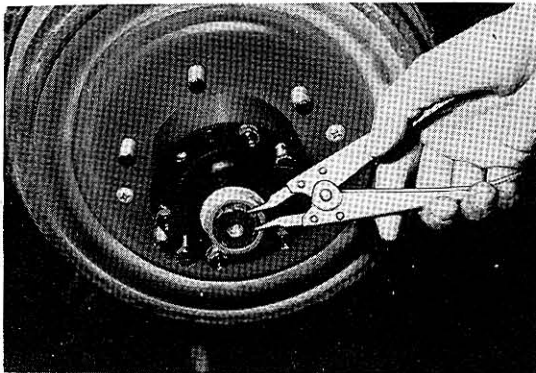

Fig.5-4 Removing Shaft V5107 Snap Ring

6. Remove the bolts retaining the axle outer shaft flange onto the front axle hub, then screw in the two service bolts into the shaft flange

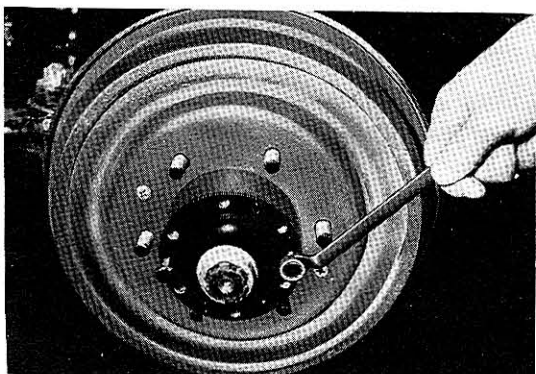

Fig.5-5 Axle Outer Shaft Frange Removal V5108

alternately, and remove the shaft flange with the gasket.

7. Remove the brake drum set screws and remove the brake drum.
8. Straighten the lock washer, and remove the front wheel adjusting nuts with the Front Wheel Adjusting Nut Wrench 09607-60010.

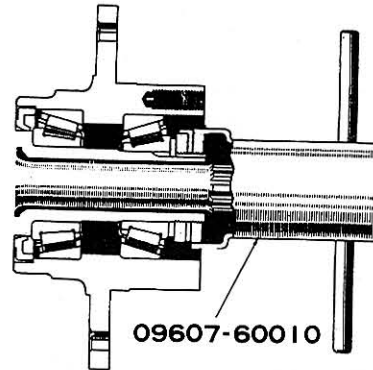

Fig.5-6 Front Wheel G2414 Adjusting Nut Removal

9. Remove the front axle hub together with the claw washer, bearings and the oil seal.
10. Remove the clip, and disconnect the brake flexible hose from the brake tube.
11. Cut and remove the lock wire, and remove the bolts retaining the brake backing plate onto the steering knuckle. Remove the brake backingplate together with the brake shoes, tension springs and the wheel cylinders.
12. Tap the steering knuckle spindle lightly with a mallet, and remove the steering knuckle spindle with the gasket. Care should be exercise since the outer shaft and the joint ball will also come off at the same time.
13. Slide the front axle inner shaft out of the axle housing.

14. Remove the screws, and take out the steering knuckle oil seal covers.
15. Remove the nuts retaining the steering knuckle arm onto the steering knuckle.  
Next, hold a short drift firmly onto the side of the dowel and strike it sharply to loosen the dowel. Remove the dowels from the steering knuckle arm.
16. Using the Steering Knuckle Bearing Remover 09606-60010, remove the steering knuckle arm from the steering knuckle.

**Caution:**

Do not lose the steering knuckle adjusting shim/s that are installed between the steering knuckle arm and the steering knuckle. Record the position and thickness of the shim/s so that they can be installed in their original position.

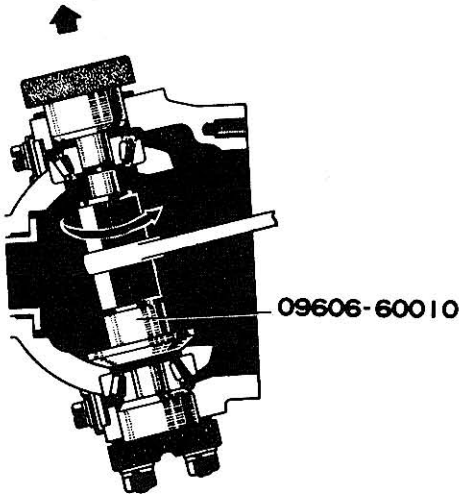

Fig.5-7 Steering Knuckle G2415 Arm Removal

17. Remove the steering knuckle bearing cap retaining nuts, and the dowels in the same manner as paragraph 15.  
Next, remove the steering knuckle bearing cap with the Steering

Knuckle Bearing Remover 09606-60010 as illustration. Remove the steering knuckle adjusting shim/s.

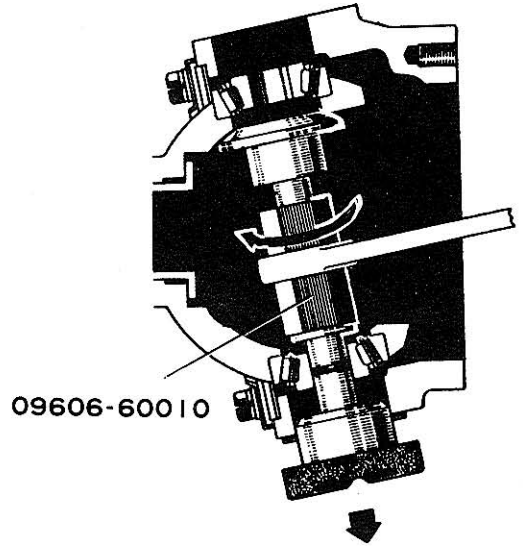

Fig.5-8 Steering Knuckle G2416 Bearing Cap Removal

18. Be careful not to drop the bearings on the ground, and remove the steering knuckle with the bearings from the axle housing.
19. Remove the steering knuckle oil seals outer and inner from the axle housing.
20. Pry off the oil seal in the front axle hub with a screwdriver, and then remove the bearing from the front axle hub.

Inspection & Repair

Clean all parts thoroughly with cleaning solvent, and dry with compressed air.

Inspect the following parts, and replace if defective.

1. Inspect the grooves on the joint ball for abnormal wear, cracks or other defects.
2. Inspect the joint portions of the

axle inner shaft and the outer shaft for abnormal wear, chips, warp-  
age or scores.

3. Inspect the splines on the axle inner shaft end for chips, nicks or excessive wear.
4. Inspect the machined surfaces of the axle inner shaft, and the outer shaft for scores or excessive wear. The specified diameter is 31.970 to 31.991 mm (1.2586 ~ 1.2595").
5. Inspect the bushing in the axle housing for scores, excessive wear or other defects. If necessary, replace the bushing.

a. To remove, use the Front Axle Shaft Bearing Puller 09619-60010, and remove the bushing from the axle housing as illustrated.

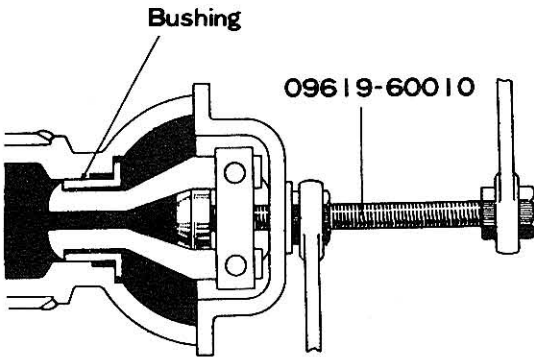

Fig.5-9 Bushing Removal G2417

b. To install, drive the bushing into the axle housing with the Front Axle & Drive Shaft Bearing Replacer 09618-60010.

**Caution:**

The bushings are provided with two kinds; the right side bushing with Part No. 90999-70061, and the left side bushing with Part No. 90999-70062.

6. Inspect the bushing in the steering knuckle spindle for scores, excessive wear or other defects. If necessary, replace the bushing.

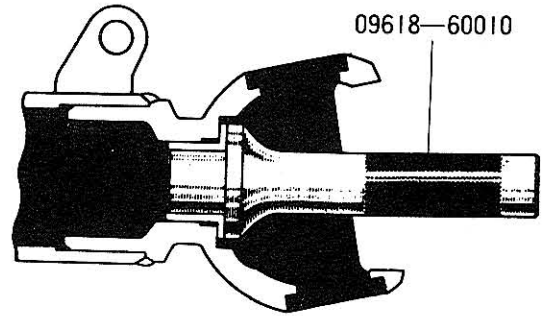

Fig.5-10 Bushing Installation G2418

a. To remove, use the Steering Worm Bearing Puller 09612-65010, and remove the bushing from the steering knuckle spindle.

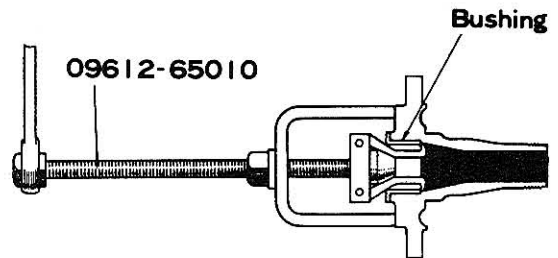

Fig.5-11 Bushing Removal G2419

b. Install the bushing into the steering knuckle spindle with the Front Axle & Drive Shaft Bearing Replacer 09618-60010 and a press.

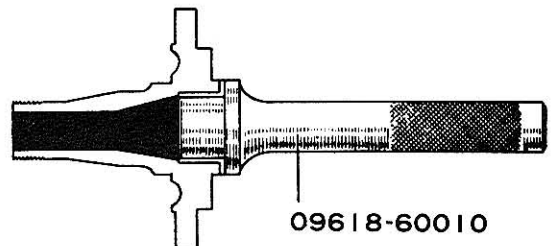

Fig.5-12 Bushing Installation G2420

cardiagn.com

7. Inspect the bearing fitting portions and the oil seal contact surface on the steering knuckle spindle for scores, pits or wear.
8. Check the steering knuckle arm, steering knuckle and the front axle hub for cracks or other defects.
9. Check the bearings for roughness, wear and rusty condition. Check the bearing for abnormal noise or damage by rotating the bearing after applying few drops of oil.

a. If necessary, remove the bearing cups from the axle housing with the Steering Worm Bearing Puller 09612-65010.

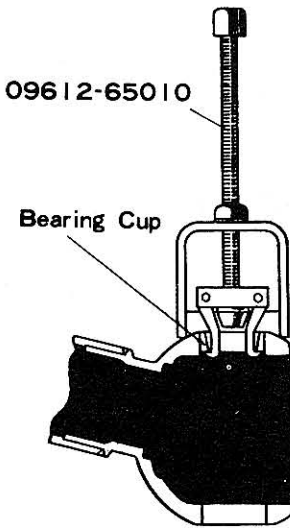

Fig.5-13 Knuckle Bearing G2421 Cup Removal

b. To install, use the Steering Knuckle Bearing Cup Replacer 09605-60010 and drive the bearing cups into the axle housing.

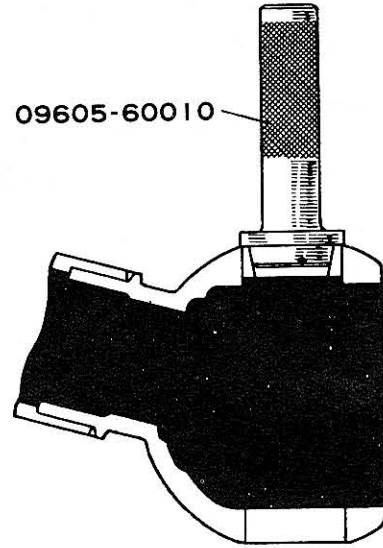

Fig.5-14 Knuckle Bearing G2422 Cup Installation

c. Drive out the inside bearing cup from the front axle hub using a brass rod.

Next, drive out the outside bearing cup in the same manner.

d. Drive the bearing cups into the front axle hub with a brass rod. Lubricate the inside bearing with multipurpose grease, and install it into the front axle hub.

Next, install a new oil seal into the front axle hub.

### Adjustment

Before assembling the steering knuckle onto the axle housing, the following adjustment should be performed.

The purpose of using the Steering Knuckle Centering Gauge 09634-60012 is to obtain true horizontal and vertical alignments of the front axle with respect to the ball joint through the outer shaft, ball joint through the axle inner shaft, and the steering knuckle upper bearing through the ball joint and the steering knuckle lower bearing.

Effecting the adjustments using the Steering Knuckle Centering Gauge, premature wear of the axle inner shaft bushing and outer shaft bushing and abnormal vibra-

tions produced while making a sharp turn on a curve can be reduced to a great extent.

Before proceeding with the adjustments, remove all grease from the related parts. Dry and inspect each part for wear and other defects, and replace if necessary.

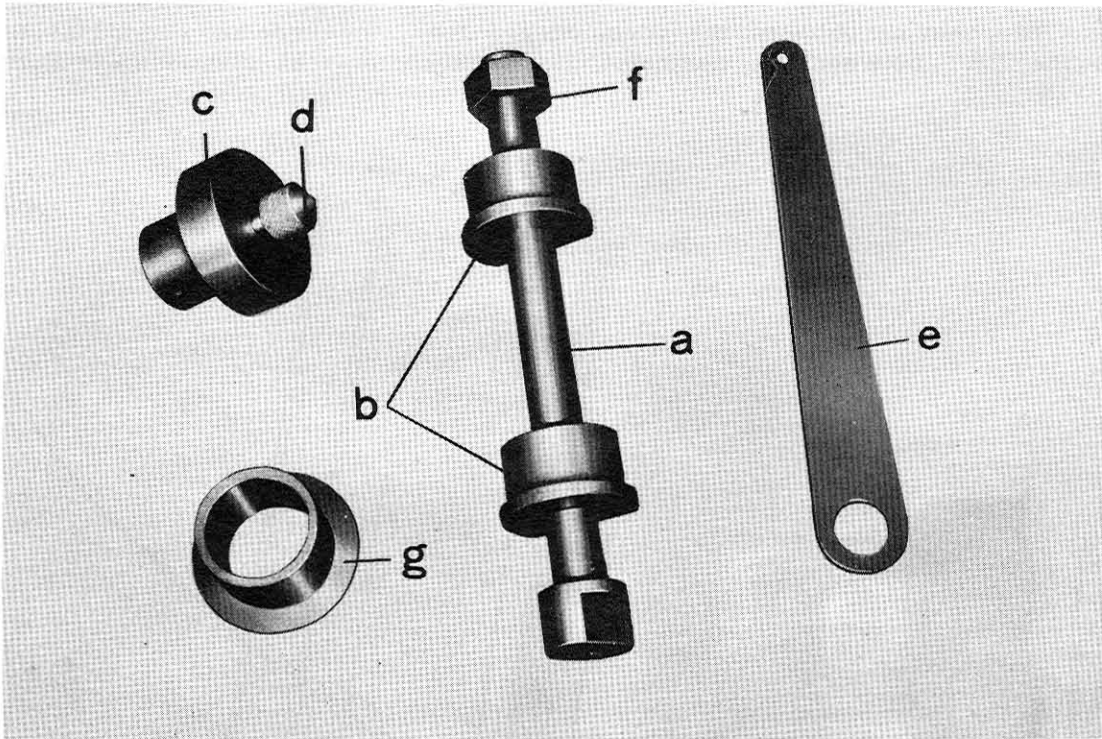

Fig.5-15 Steering Knuckle Centering Gauge

V5148

#### 1. Steering knuckle bearing pre-load.

a. Install the centering gauge adapter (c) with the plug (d) into the axle inner shaft bushing.

Caution:

The axle shaft of the birfield joint type is not provided with the bushing in the axle housing, therefore, before installing the centering gauge adapter (c), remove the oil seal in the axle housing end, and the centering gauge adapter (g) should be installed instead of the axle inner shaft bushing into the axle housing end, and then install the centering gauge adapter (c) with the plug (d) into the axle housing.

b. Install the centering gauge attachment (b) and the steering knuckle lower bearing onto the centering gauge rod (a), then assemble the centering gauge rod onto the axle housing end from the bottom as illustrated in figure 5-16.

c. Next, install the steering knuckle upper bearing, centering gauge attachment (b) and the centering gauge lever (e) onto the centering gauge rod (a), then install and tighten the centering gauge nut (f), but do not tighten excessively.

5-12 FRONT AXLE & FRONT SUSPENSION - Steering Knuckle & Axle Shaft

d. Attach a pull-scale to the end of the centering gauge lever (e), and while exerting a steady pull on the pull-scale at right angle to the lever, note the reading on the pull-scale.

If the reading is not within 2.0 ~ 2.5 kg (4.4 ~ 5.5 lb), loosen or tighten the nut until the specified pre-load is obtained.

e. After having obtained the specified pre-load, measure and record the distance "A" between the centering gauge attachments as illustrated in figure 5-16.

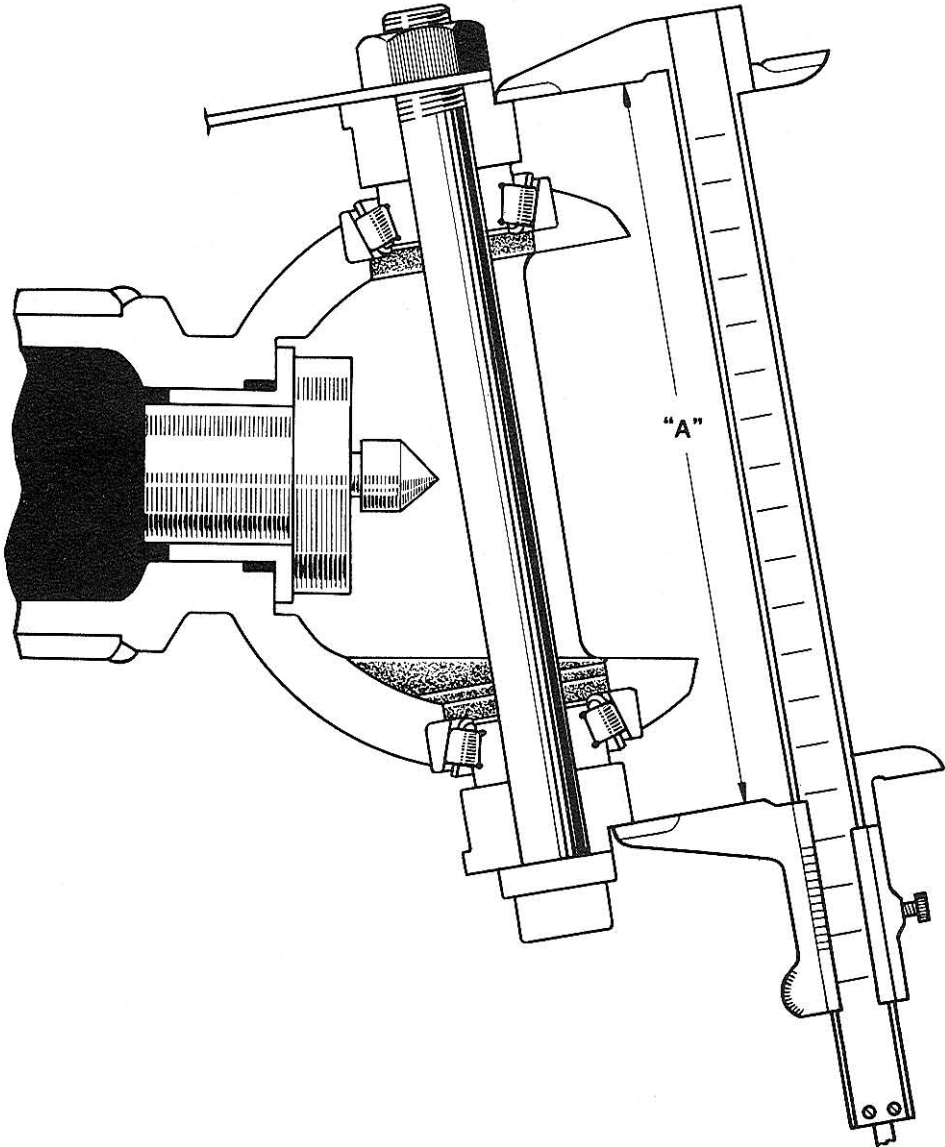

Fig.5-16 Measuring Distance "A"

G2423

f. Measure and record the height "B" of the steering knuckle as illustrated in figure 5-17.

cardiagn.com

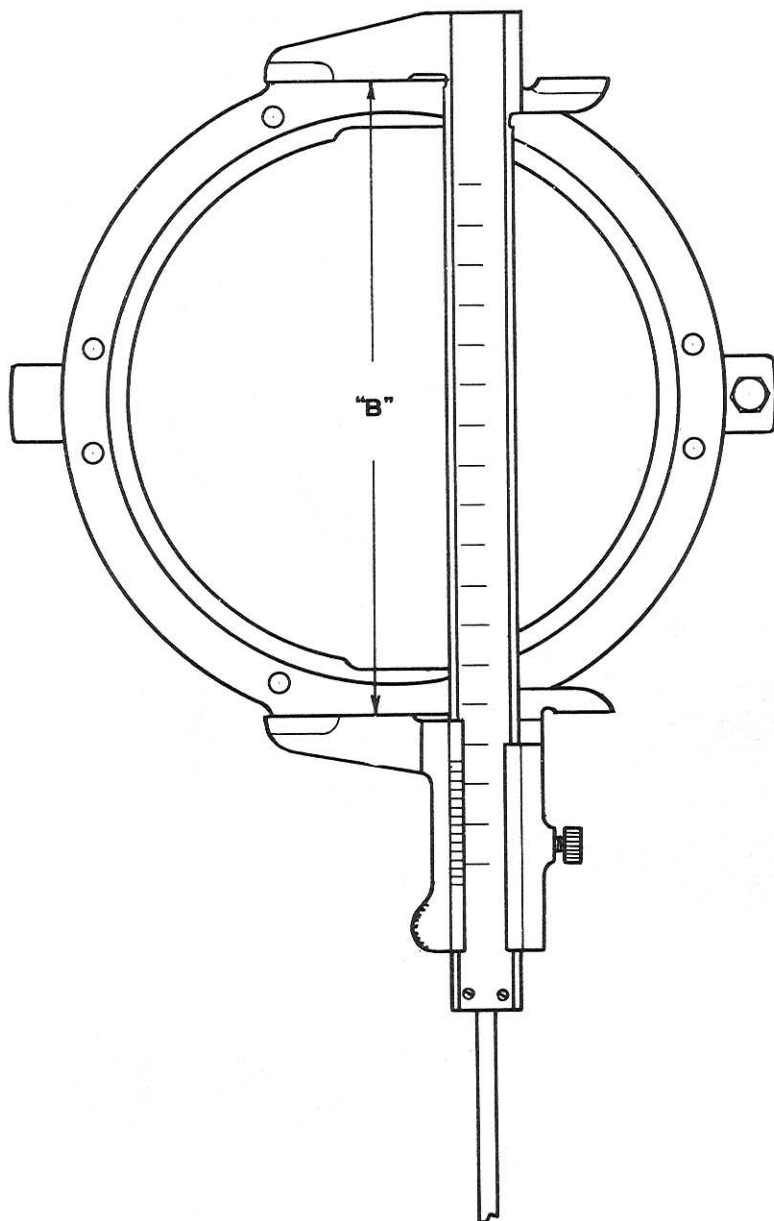

Fig.5-17 Measuring Height of Steering Knuckle

G2424

g. The difference between "A" and "B" is the total adjusting shim thickness that is required to maintain the correct bearing pre-load.

Total adjusting shim thickness "C" equals "A" minus "B".

Adjustment of upper and lower adjusting shim thickness.

Perform the following procedure with the Steering Knuckle Centering Gauge 09634-60012 in the assembled condition as per the previous paragraph.

a. Apply thin coat of red-lead onto the middle part of the centering gauge

## 5-14 FRONT AXLE & FRONT SUSPENSION - Steering Knuckle & Axle Shaft

rod so that a line can be produced when the centering gauge rod is revolved with respect to the plug.

Now, revolve the centering gauge rod while pressing the plug against the centering gauge rod and adapter to produce a clear line around the centering gauge rod as illustrated in figure 5-18.

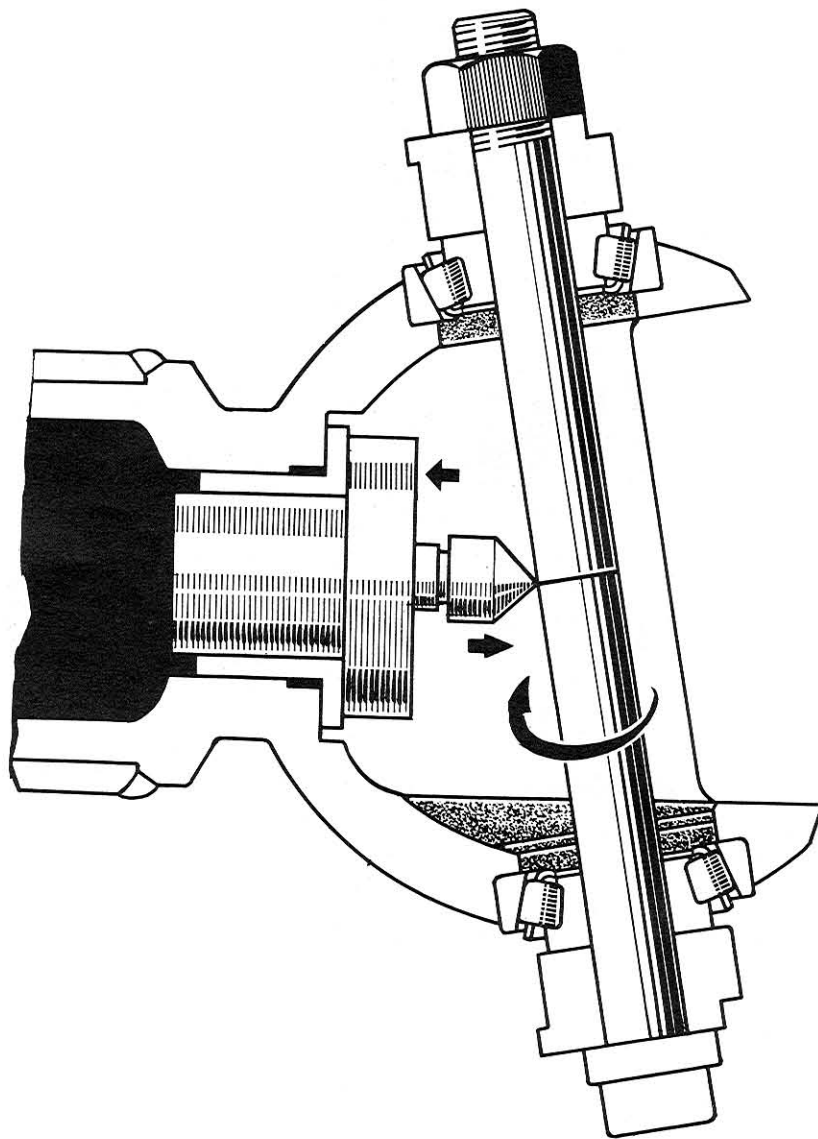

Fig.5-18 Scribing a Line on Centering Gauge Rod

G2425

b. Taking care not to rub off the scribed line on the centering gauge rod, remove the Steering Knuckle Centering Gauge from the axle housing.

c. Install the steering knuckle spindle onto the steering knuckle, and tighten the bolts to 1.5 ~ 2.2 m-kg (11 ~ 16 ft-lb) torque.

Next, install the centering gauge adapter (c) with the plug (d) into the steer

ing knuckle spindle, and install the centering gauge rod (a) and attachments (b) into the steering knuckle as illustrated in figure 5-19, and tighten the nut (f).

d. Mark another line on the centering gauge rod by revolving the centering gauge rod in the steering knuckle in the same manner as performed in paragraph 2-a.

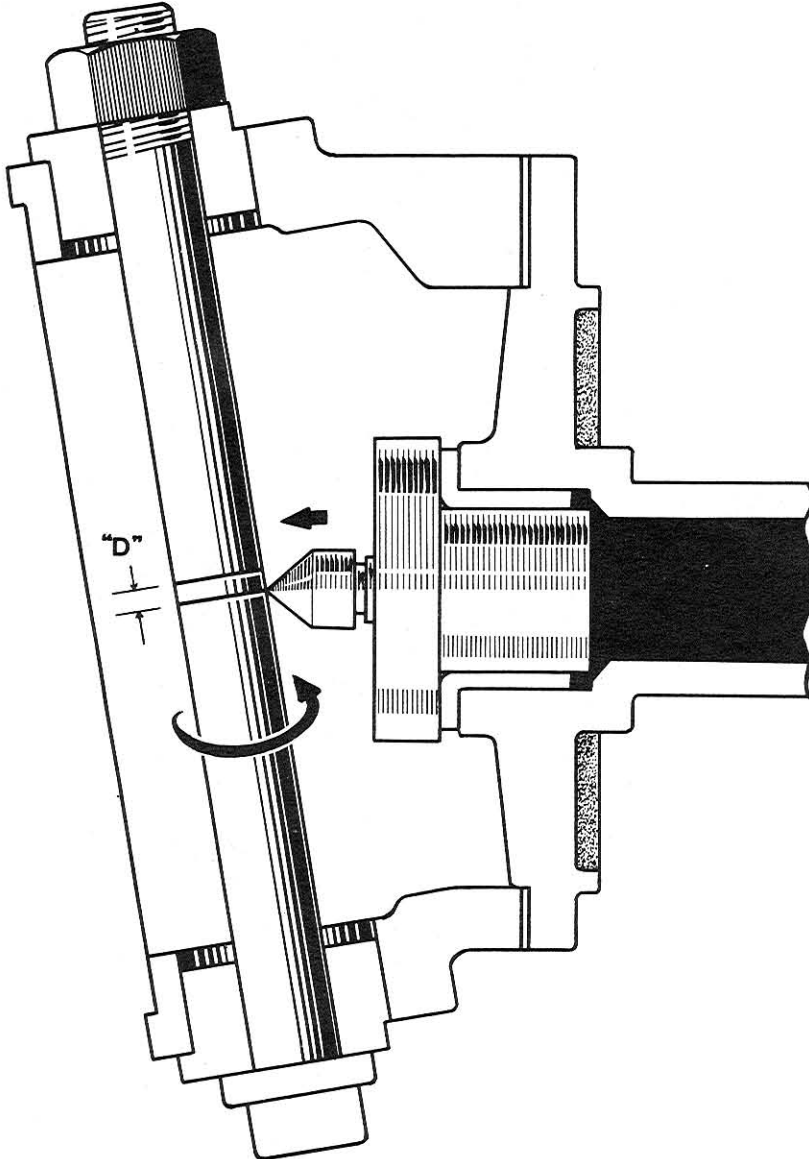

Fig.5-19 Scribing a Line on Centering Gauge Rod

G2426

e. Measure and record the distance "D" between the two scribed lines on the centering gauge rod.

Subtract 3 mm from the distance "D" just obtained.

The difference will be the adjusting shim thickness required for the steering knuckle lower bearing.

## 5-16 FRONT AXLE & FRONT SUSPENSION - Steering Knuckle & Axle Shaft

Lower bearing adjusting shim thickness "E" equals "D" minus 3 mm.

f. Steering knuckle upper bearing adjusting shim thickness will be determined by subtracting "E" from the total adjusting shim thickness "C". Upper bearing adjusting shim thickness equal "C" minus "E".

The knuckle bearing adjusting shims are provided as follows.

Part No. 43233-60010 - Thickness: 0.2 mm (0.008")

Part No. 43234-60010 - Thickness: 0.5 mm (0.020")

### 3. Adjustment of the shaft thrust clearance.

a. To check the axle inner shaft thrust clearance, install the Steering Knuckle Centering Gauge 09634-60012 onto the axle housing as described in the previous paragraph 1, and check the clearance between the plug (d) and the centering gauge rod (a) with a feeler gauge. This clearance is the thrust clearance between the bushing and the axle inner shaft. This clearance should be 0.5 ~ 1.0 mm (0.02 ~ 0.04"). Select and fit the front axle shaft spacer to obtain the specified clearance. The front axle shaft spacers are special service parts, and are provided as follows.

Part No. 04002-20160 - Thickness: 1.0 mm (0.04")

Part No. 04002-20460 - Thickness: 1.5 mm (0.06")

Part No. 04002-20560 - Thickness: 2.0 mm (0.08")

b. To check the outer shaft thrust clearance, install the Steering Knuckle Centering Gauge onto the steering knuckle as described in the previous paragraph 2-c, and check the clearance between the plug (d) and the centering gauge rod (a) with a feeler gauge. This clearance should be also 0.5 ~ 1.0 mm (0.02 ~ 0.04"). If necessary, adjust by selecting the front axle shaft spacer to obtain the specified clearance.

### Assembly & Installation

When assembling, the oil seals, gas-kets and the lock washers should be replaced.

To provide initial lubrication, apply a thin coating of multipurpose grease on all rotating or sliding portions, and the bearings before installation.

1. Place the steering knuckle oil seal set onto the axle housing.
2. Place the steering knuckle upper and lower bearings onto the bearing cups in the axle housing, then install the steering knuckle.
3. Install the steering knuckle bearing adjusting shims which were determined during the previous adjustment onto the steering knuckle arm, and then install the steering knuckle arm with the adjusting shims

onto the steering knuckle. Next, install the steering knuckle bearing cap and the bearing adjusting shims onto the steering knuckle into the bearing.

4. Insert the dowels into the steering knuckle arm, and the steering knuckle bearing cap, then tighten the retaining nuts to 6 ~ 7.5 m·kg (43 ~ 54 ft·lb) torque.
5. Next, check the bearing pre-load of the steering knuckle. Attach a pull-scale to the end hole of the steering knuckle arm at right angle. The reading of the pull-scale should be 1.8 ~ 2.3 kg (3.9 ~ 5.0 lb). If necessary, re-adjust the bearing pre-load.

Caution:

1. Preload checking should be performed without the axle shaft, steering knuckle spindle, and etc.
2. Install the same number of steering knuckle bearing adjusting shims which were determined at the previous adjustment on both upper and lower of the steering knuckle.

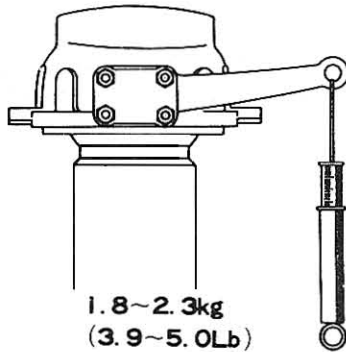

Fig.5-20 Checking Steering G2427 Knuckle Bearing Pre-load

6. Install the front axle shaft spacer which were determined at the previous adjustment onto the axle inner shaft, and then install the axle inner shaft into position until the splines on the shaft end is fully meshed with the differential side gear splines.
7. Pack the steering knuckle with multipurpose grease to about 3/4 of the interior area. Place the front drive joint ball on to the axle inner shaft.
8. Install the outer shaft and the front axle shaft spacer into the steering knuckle spindle, and then install the steering knuckle spindle with the gasket onto the steering knuckle.
9. Assemble the brake backing plate with the knuckle spindle oil retainer and the gasket onto the steering knuckle spindle.

Tighten the backing plate retaining bolts to 1.5 ~ 2.2 m·kg (11 ~ 16 ft·lb) torque, and secure with a steel wire. Install the steering knuckle oil seal covers and secure the retaining screws.

10. Pack the axle hub with multipurpose grease, and assemble the axle hub together with the brake drum onto the steering knuckle spindle, then install the axle hub outer bearing.
11. Install the claw washer and tighten the front wheel adjusting nut with the Front Wheel Adjusting Nut Wrench 09607-60010. Rotate the brake drum to-and-fro to seat the bearings into place. Next, loosen the adjusting nut 1/8 to 1/6 of a turn, and check the brake drum rotation. If the brake drum rotates properly, install the lock washer and tighten the lock nut with the Front Wheel Adjusting Nut Wrench 09607-60010. Bend the tabs of the lock washer, and lock the nuts.

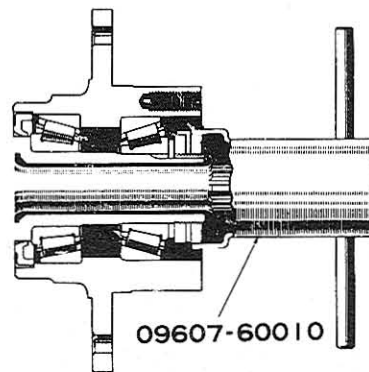

Fig.5-21 Tightening Lock G2414 Nut

12. After the adjustment, install the

5-18 FRONT AXLE & FRONT SUSPENSION - Steering Knuckle & Axle Shaft

axle outer shaft flange with the gasket.  
Tighten the flange retaining bolts to 1.5 ~ 2.2 m-kg (11 ~ 16 ft-lb) torque.

13. Install the shaft snap ring onto the outer shaft.  
Install a bolt into the outer shaft end, and while pulling the outer shaft outward install the snap ring onto the shaft.  
Install the axle outer shaft flange cap onto the outer shaft flange.
14. Check if the axle shaft is free from binding in the steering knuckle spindle by turning the steering knuckle from one extreme end to the other.
15. Connect the steering tie-rod end with the steering knuckle arm, and tighten the nut securely.  
Install the cotter pin.

16. Connect the brake flexible hose with the brake tube.  
Bleed the air from the hydraulic line.  
Adjust the brakes. Refer to Brake Adjustment on page 7-5.
17. Install the wheel, remove the stands and lower the vehicle onto the ground.  
Tighten the hub nuts securely, and fit the wheel cap.
18. During road testing of the vehicle, check the ease of the steering control, by turning the steering wheel to the right and to the left.

\* \* \* \* \*

Birfield Constant Velocity Joint Type

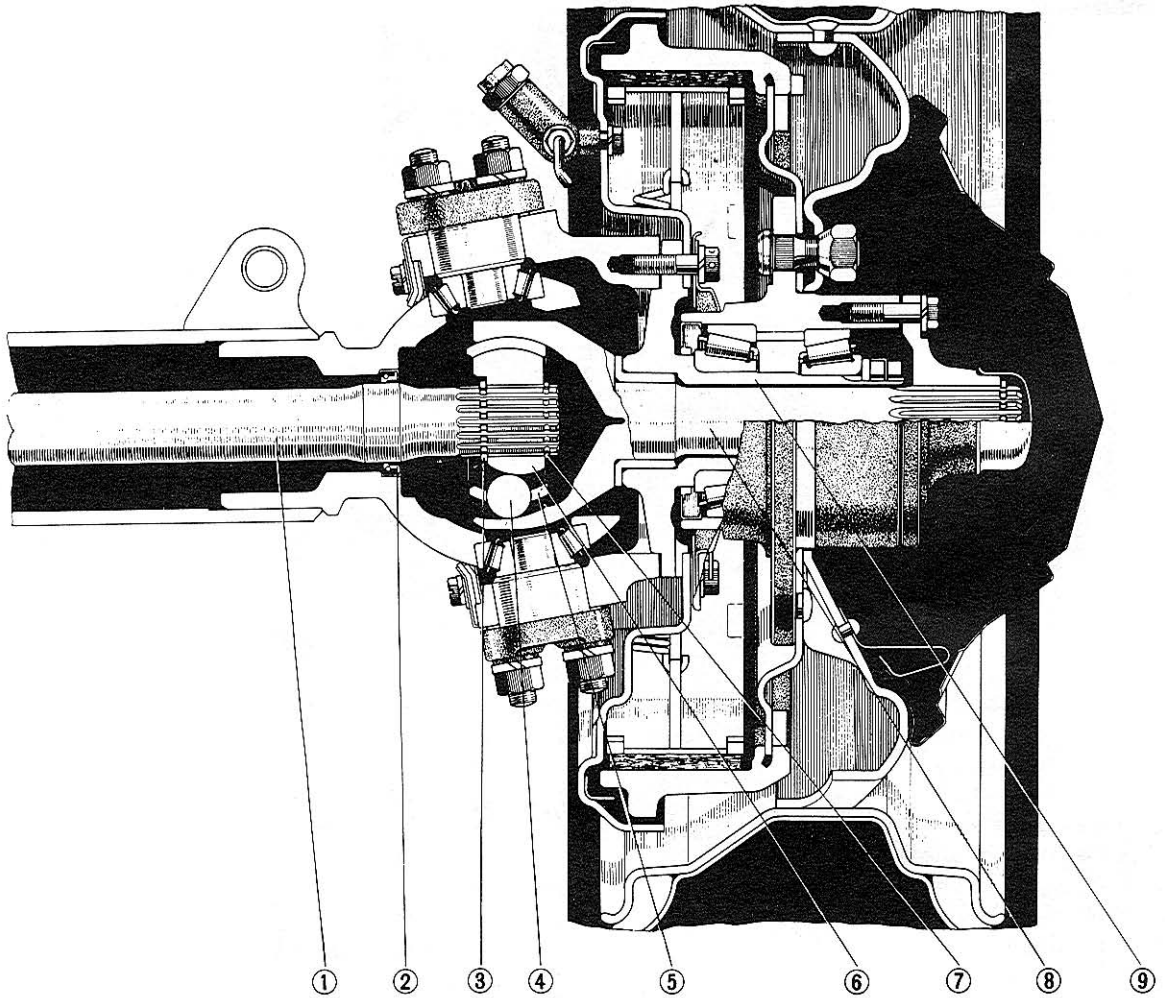

- 1. Front axle inner shaft
- 2. Oil seal
- 3. Shaft snap ring
- 4. Bearing ball
- 5. Joint cage

- 6. Joint inner race
- 7. Shaft snap ring
- 8. Front axle outer shaft
- 9. Steering knuckle spindle

Fig.5-22 Cross Section View of Steering Knuckle & Axle Shaft Y5732

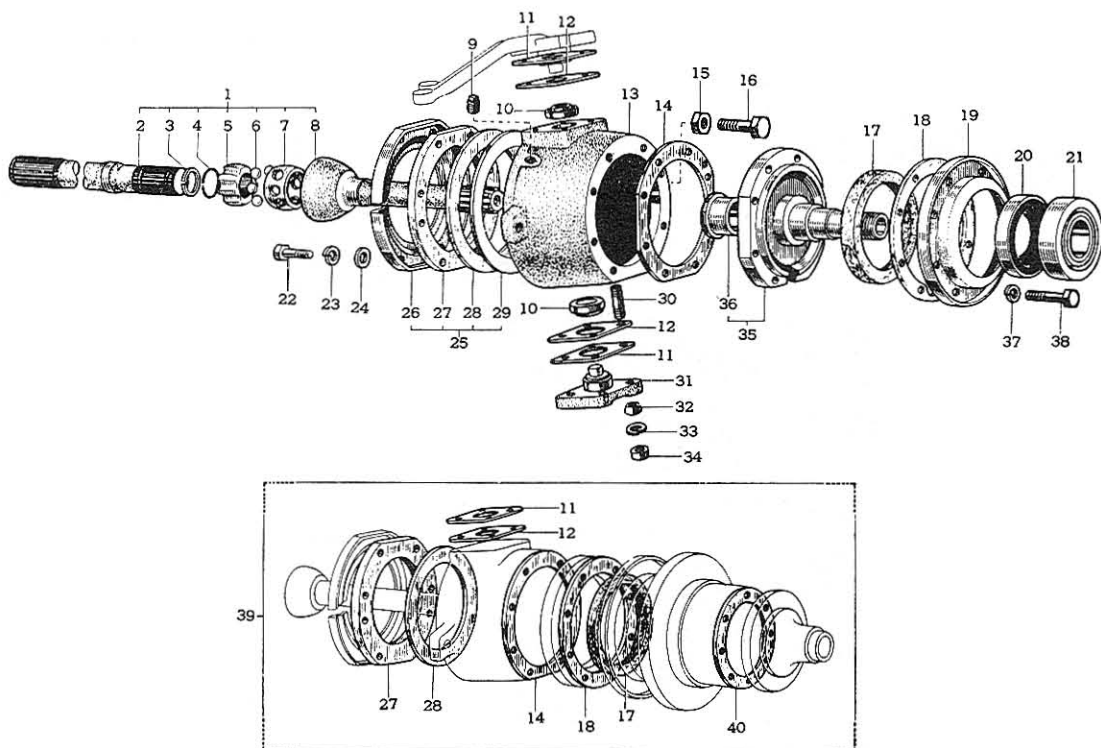

- |                               |                                  |
|-------------------------------|----------------------------------|
| 1. Front drive shaft assembly | 21. Axle hub inner bearing       |
| 2. Axle inner shaft           | 22. Bolt                         |
| 3. Shaft snap ring            | 23. Lock washer                  |
| 4. Shaft snap ring            | 24. Washer                       |
| 5. Joint inner race           | 25. Oil seal set                 |
| 6. Ball                       | 26. Oil seal cover               |
| 7. Joint cage                 | 27. Outer oil seal               |
| 8. Axle outer shaft           | 28. Inner oil seal               |
| 9. Plug                       | 29. Oil seal inner ring          |
| 10. Steering knuckle bearing  | 30. Stud bolt                    |
| 11. Adjusting shim No.1       | 31. Steering knuckle bearing cap |
| 12. Adjusting shim No.2       | 32. Dowel                        |
| 13. Steering knuckle          | 33. Lock washer                  |
| 14. Gasket                    | 34. Nut                          |
| 15. Lock nut                  | 35. Steering knuckle spindle     |
| 16. Bolt                      | 36. Bushing                      |
| 17. Dust seal                 | 37. Lock washer                  |
| 18. Oil retainer gasket       | 38. Bolt                         |
| 19. Oil retainer              | 39. Front axle gasket kit        |
| 20. Oil seal                  | 40. Flange gasket                |

Fig. 5-23 Steering Knuckle & Axle Shaft Components

G2440

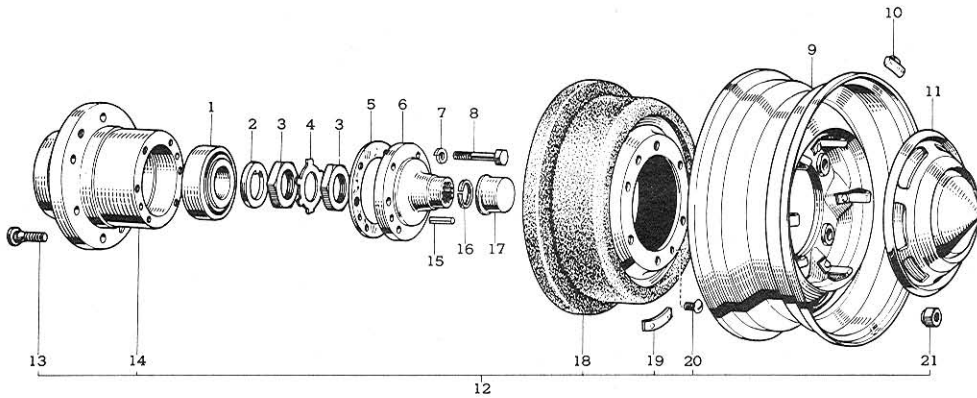

- |                                                                                                                                                                                                                                                                                                                                                    |                                                                                                                                                                                                                                                                                                                                                            |
|----------------------------------------------------------------------------------------------------------------------------------------------------------------------------------------------------------------------------------------------------------------------------------------------------------------------------------------------------|------------------------------------------------------------------------------------------------------------------------------------------------------------------------------------------------------------------------------------------------------------------------------------------------------------------------------------------------------------|
| <ol style="list-style-type: none"> <li>1. Axle hub outer bearing</li> <li>2. Claw washer</li> <li>3. Front wheel adjusting nut</li> <li>4. Lock washer</li> <li>5. Flange gasket</li> <li>6. Axle outer shaft flange</li> <li>7. Lock washer</li> <li>8. Bolt</li> <li>9. Disc wheel</li> <li>10. Balance weight</li> <li>11. Wheel cap</li> </ol> | <ol style="list-style-type: none"> <li>12. Front axle hub &amp; brake drum assembly</li> <li>13. Hub bolt</li> <li>14. Front axle hub</li> <li>15. Straight pin</li> <li>16. Shaft snap ring</li> <li>17. Axle outer shaft flange cap</li> <li>18. Brake drum</li> <li>19. Balance piece</li> <li>20. Brake drum set screw</li> <li>21. Hub nut</li> </ol> |
|----------------------------------------------------------------------------------------------------------------------------------------------------------------------------------------------------------------------------------------------------------------------------------------------------------------------------------------------------|------------------------------------------------------------------------------------------------------------------------------------------------------------------------------------------------------------------------------------------------------------------------------------------------------------------------------------------------------------|

Fig.5-24 Front Disc Wheel & Drum Components

G2441

Removal & Disassembly

1. Pry off the wheel cap, and loosen the hub nuts.
2. Jack up the front axle housing, and support the axle housing with stands.
3. Remove the hub nuts and remove the wheel.
4. Plug the brake master cylinder reservoir to prevent brake fluid from running out from the disconnect the brake flexible hose.
5. Remove the axle outer shaft flange cap, and then remove the shaft snap ring from the axle outer shaft.
6. Remove the axle outer shaft flange retaining bolts, then next, screw in the two service bolts into the shaft flange alternately, and remove the shaft flange with the gasket.

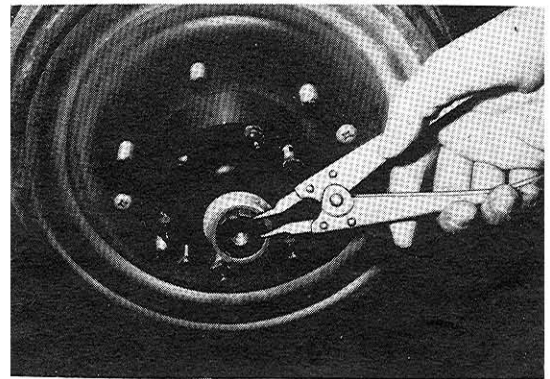

Fig.5-25 Removing Shaft V5107 Snap Ring

7. Remove the brake drum set screws and remove the brake drum.
8. Straighten the lock washer tabs, and remove the front wheel adjusting nuts with the Front Wheel Adjusting Nut Wrench 09607-60010.
9. Remove the front axle hub with the claw washer, bearing and the oil seal.

cardiagn.com

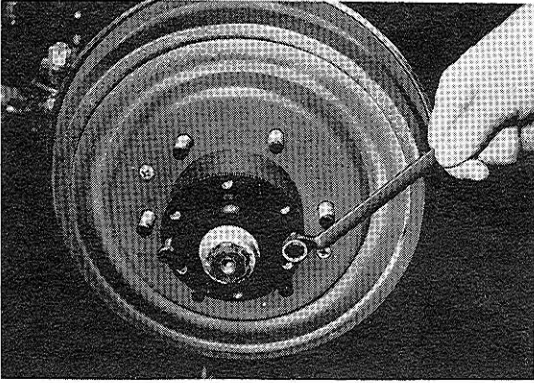

Fig.5-26 Removing Axle V5108  
Outer Shaft Flange

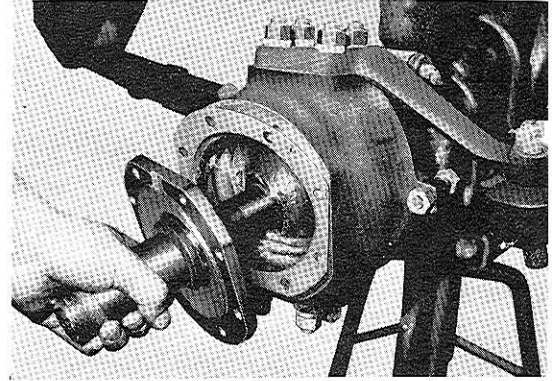

Fig.5-28 Removing Steering V5109  
Knuckle Spindle

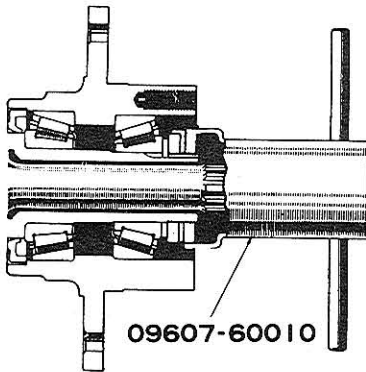

Fig.5-27 Front Wheel Ad- G2414  
justing Nut Removal

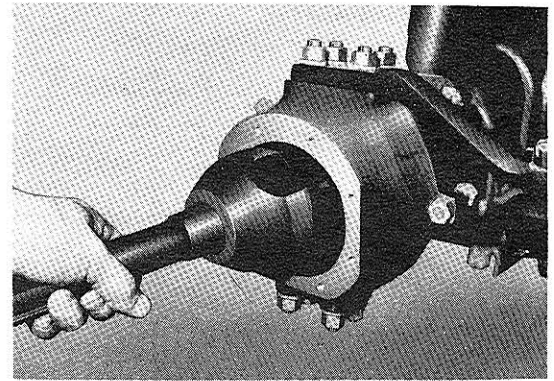

Fig.5-29 Removing Front V5110  
Drive Shaft

10. Remove the clip, and disconnect the brake flexible hose from the brake tube.
11. Cut and remove the lock wire, and remove the bolts retaining the brake backing plate onto the steering knuckle. Remove the brake backing plate assembly.
12. Tap the steering knuckle spindle lightly with a mallet, and remove it with the gasket.
13. Pull out the front drive shaft assembly from the axle housing.

14. Remove the steering knuckle oil seal covers.
15. Disconnect the tie-rod end from the steering knuckle arm using the Tie-rod End Puller 09611-20011.
16. Remove the nuts retaining the steering knuckle arm on the steering knuckle. Next, hold a short drift firmly onto the side of the dowel, and strike it sharply to loosen the dowel. Remove the dowels from the steering knuckle arm.
17. Next, using the Steering Knuckle Bearing Remover 09606-60010 remove the steering knuckle arm from the steering knuckle.

**Caution:**

Do not lose the steering knuckle adjusting shims which are installed between the steering knuckle arm

and the steering knuckle. Record the position, and thickness of the shims so that they can be installed in their original location.

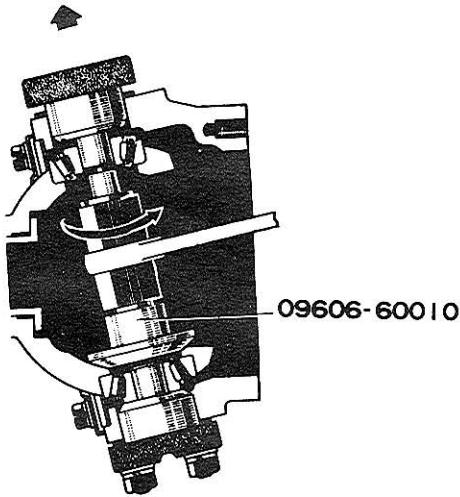

Fig.5-30 Steering Knuckle G2415 Arm Removal

18. Remove the steering knuckle bearing cap retaining nuts, and the dowels in the same manner as in paragraph 16.

Next, remove the steering knuckle bearing cap with the Steering Knuckle Bearing Remover 09606-60010.

Remove the steering knuckle adjusting shims.

19. Be careful not to drop the steering knuckle bearings onto the ground, and remove the steering knuckle with the bearings from the axle housing.
20. Remove the steering knuckle outer and inner oil seals from the axle housing.
21. Pry off the oil seal in the front axle hub with a screwdriver, and remove the bearing from the front axle hub.

Inspection & Repair

Clean all disassembled parts thoroughly with cleaning solvent and dry with compressed air.

Inspect the following parts, and replace if defective.

1. Inspect the splines on the front drive shaft end for chips, nicks or excessive wear.
2. Check the oil seal and bushing contact surface on the front drive shaft for scores or excessive wear.
3. Check the joint of the front drive shaft for smooth operation, and if necessary, replace the defective parts.  
Inspect each of the disassembled parts for wear, scores and cracks.

a. To disassemble the joint, secure the front axle inner shaft in a vise, and apply a brass rod against the joint inner race, and drive out the front axle outer shaft with the joint inner race off the front axle inner shaft.

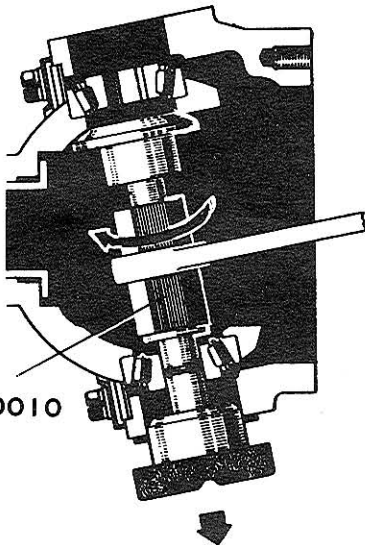

Fig.5-31 Steering Knuckle G2416 Bearing Cap Removal

The snap ring on the front axle inner shaft end will break by the impact.

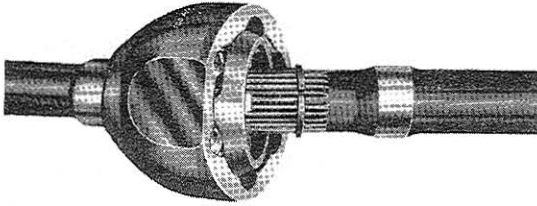

Fig. 5-32 Joint Disassembly V3947

b. Push down on one side of the joint inner race, and remove the bearing ball onto the other side from the cage.  
In the same manner, remove the rest of the bearing balls.

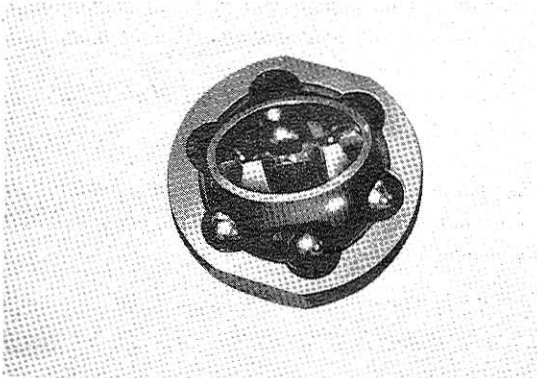

Fig. 5-33 Bearing Ball Removal V5111

c. The cage has two large openings among the six which are symmetrically located.  
Turn the cage together with the joint inner race in the housing of the front axle outer shaft 1/2 of a turn to bring them to upright position.  
Through the openings, manage to remove both parts out of the housing.

d. Through the large openings, remove the joint inner race from the cage.

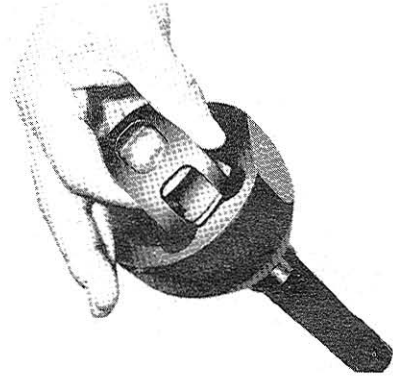

Fig. 5-34 Removing Cage V5112 & Joint Inner Race

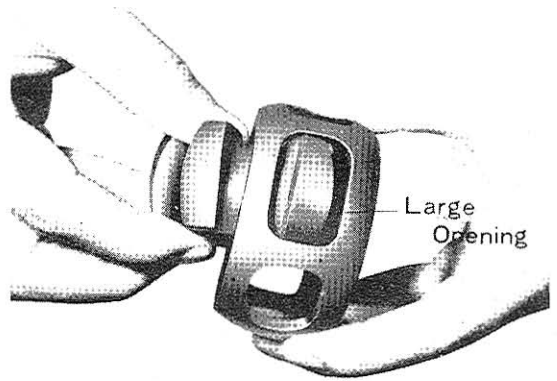

Fig. 5-35 Removing Joint Inner Race V5113

e. Before assembly, lubricate the joint related parts with multipurpose grease.  
To assemble, install the joint inner race into the joint cage with the flat end of the joint inner race facing towards the joint cage narrower side.

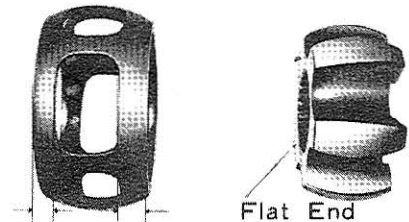

Fig. 5-36 Joint Inner Race V5114 & Joint Cage

f. Assemble the joint cage and the joint inner race into the housing of the front axle outer shaft with the protrusions of the joint inner race facing outward, then assemble the bearing balls into the cage.

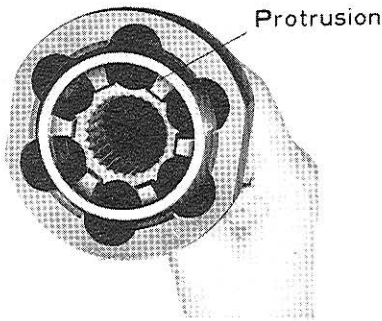

Fig. 5-37 Joint Inner Race V5115 & Cage Assembly

g. Install a new snap ring (inner) into the groove of the front axle inner shaft end. Squeeze the snap ring, and fit the axle inner shaft into the joint inner race until the outer shaft snap ring contacts with the inner race. With the front axle inner shaft in this position, the inner shaft snap ring will expand to lock the front axle inner shaft in place.

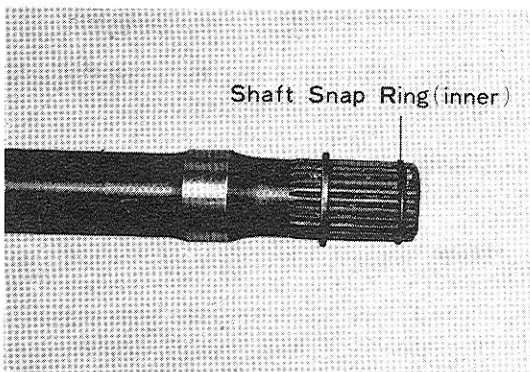

Fig. 5-38 Shaft Snap Ring V5116 Installation

If necessary, replace the bushing.

a. To remove, use the Steering Worm Bearing Puller 09612-65010 and remove the bushing from the steering knuckle spindle.

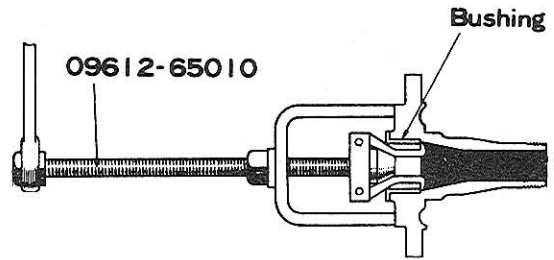

Fig. 5-39 Bushing Removal G2419

b. Install the bushing into the steering knuckle spindle with the Front Axle & Drive Shaft Bearing Replacer 09618-60010 and a press.

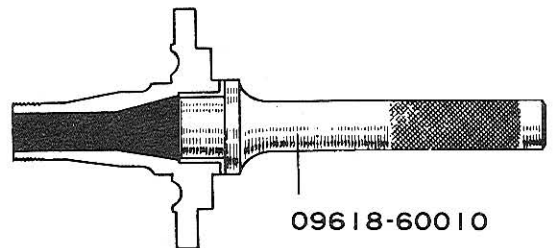

Fig. 5-40 Bushing Installation G2420

- h. Check the assembled joint for smooth movement.
4. Inspect the bushing in the steering knuckle spindle for scores, excessive wear or other defects.

5. Inspect the bearing fitting portions and the oil seal contacting surface on the steering knuckle spindle for scores, pits or wear.
6. Check the steering knuckle arm, steering knuckle and the front axle hub for cracks or other defects.
7. Check the bearings for roughness, wear and rusty condition. Check the bearing for abnormal noise or damage by rotating the bearings after applying few drops

of oil.

a. If necessary, remove the bearing cups from the axle housing with the Steering Worm Bearing Puller 09612-65010.

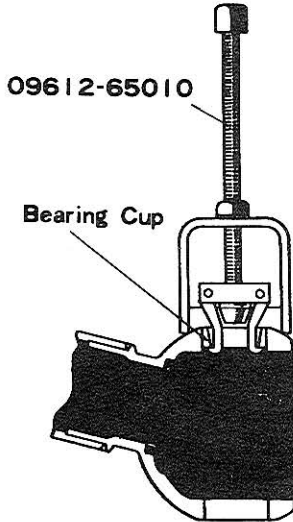

Fig.5-41 Knuckle Bearing G2421 Cup Removal

b. To install, use the Steering Knuckle Bearing Cup Replacer 09605-60010, and drive the bearing cups into the axle housing.

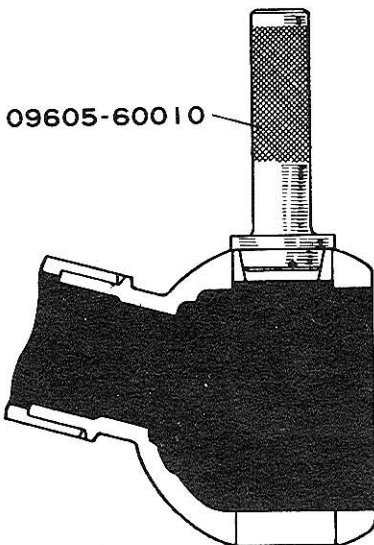

Fig.5-42 Knuckle Bearing G2422 Cup Installation

c. Drive out the inside bearing cup from the front axle hub with a brass rod.

Next, drive out the outside bearing cup in the same manner.

d. Drive the bearing cups into the front axle hub with a brass rod. Lubricate the inside bearing with multipurpose grease, and install it into the front axle hub.

Next, install a new oil seal into the front axle hub.

### Adjustment

Before assembling the steering knuckle onto the axle housing, the following adjustment should be performed.

For adjustment, refer to Adjustment on page 5-10.

1. Steering knuckle bearing pre-load.
2. Adjustment of upper and lower adjusting shim thickness.

### Assembly & Installation

When assembling, the oil seals, gaskets and the lock washer should be replaced.

Lubricate with multipurpose grease before installation.

1. Place the steering knuckle oil seal set onto the axle housing.
2. Place the steering knuckle upper and lower bearings onto the bearing cups into the axle housing, then install the steering knuckle.
3. Install the steering knuckle adjusting shims which were determined at the previous adjustment onto the steering knuckle arm, and then install the steering knuckle arm with the adjusting shims onto the steering knuckle.

Next, install the steering knuckle bearing cap and the bearing adjusting shims onto the steering knuckle into the bearing.

4. Insert the dowels into the knuckle arm, and install the steering knuckle bearing cap, then tighten the retaining nuts to 6.0 ~ 7.5 m-kg (43 ~ 54 ft-lb) torque.
5. Next, check the steering knuckle bearing pre-load by attaching a pull-scale to the end hole of the steering knuckle arm at right angle. The reading of the pull-scale should be 1.8 ~ 2.3 kg (3.9 ~ 5.0 lb). If necessary, re-adjust the bearing pre-load.

Caution:

1. Pre-load checking should be performed without the front drive shaft, steering knuckle spindle, and etc.
2. Install the same number of the steering knuckle bearing adjusting shims which were determined at the previous adjustment on both upper and lower of the steering knuckle.

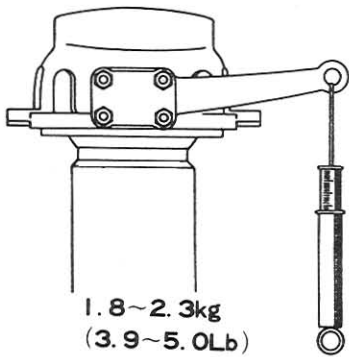

Fig.5-43 Checking Steering G2427 Knuckle Bearing Pre-load

6. Install the steering knuckle oil seal covers onto the steering knuckle.
7. Install the front drive shaft into position until the splines on the shaft end is fully meshed with the differential side gear splines.
8. Pack the steering knuckle with multipurpose grease for about 3/4 of the interior area.

9. Assemble the steering knuckle spindle with the gasket.
10. Install the brake backing plate assembly onto the steering knuckle spindle. Tighten the backing plate retaining bolts to 1.5 ~ 2.2 m-kg (11 ~ 16 ft-lb) torque, and secure with a new steel wire.
11. Pack the axle hub with multipurpose grease, and assemble the axle hub together with the brake drum onto the steering knuckle spindle, then install the axle hub outer bearing.
12. Install the claw washer and tighten the front wheel adjusting nut with the Front Wheel Adjusting Nut Wrench 09607-60010. Rotate the brake drum to-and-fro to seat the bearings into place. Next, loosen the adjusting nut 1/8 to 1/6 of a turn, and check the brake drum rotation. If the brake drum rotates properly, install the lock washer and tighten the lock nut securely with the Front Wheel Adjusting Nut Wrench 09607-60010.

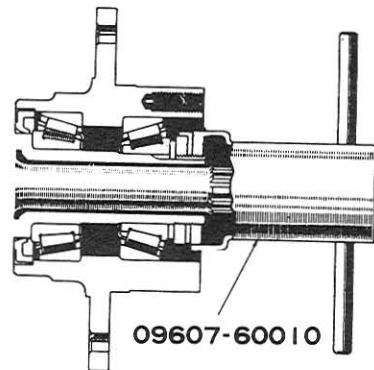

Fig.5-44 Tightening Lock G2414 Nut

- Bend the tabs of the lock washer, and lock the nuts.
13. Install the axle outer shaft flange with the gasket.  
Tighten the flange retaining bolts to 1.5 ~ 2.2 m-kg (11 ~ 16 ft-lb) torque.
  14. Install a bolt into the outer shaft end, and while pulling the outer shaft, install the snap ring onto the shaft.  
Next, install the axle outer shaft flange cap onto the axle outer shaft flange.
  15. Check if the front drive shaft is free from binding in the steering knuckle spindle by turning the steering knuckle from the extreme end to the other.
  16. Connect the steering tie-rod end with the steering knuckle arm, and tighten the nut securely.
  17. Connect the brake flexible hose to the brake tube.  
Bleed the air from the hydraulic line.  
Adjust the brakes. Refer to Brake Adjustment on page 7-5.
  18. Install the wheel, remove the stands and lower the vehicle onto the ground.  
Tighten the hub nuts securely, and fit the wheel cap.
  19. During road testing the vehicle, check the ease of the steering control, by turning the steering wheel to the right and to the left.

\* \* \* \* \*

DIFFERENTIAL

The differential on the front axle is of a hypoid gear type. As the construction of the front differential is almost identical with that utilized on the rear axle. For operation, and other procedures except Removal and Installation, refer to Differential in Rear Axle & Rear Suspension section.

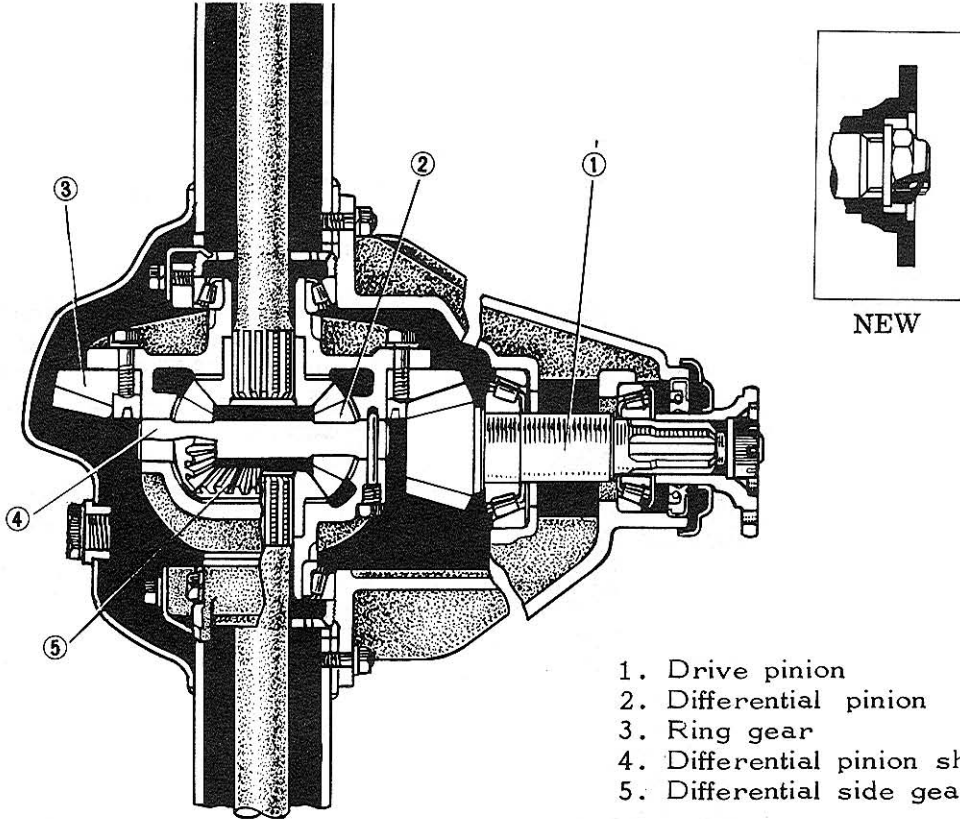

- 1. Drive pinion
- 2. Differential pinion
- 3. Ring gear
- 4. Differential pinion shaft
- 5. Differential side gear

Fig.5-45 Cross Section of Front Differential G1327

Removal

1. Pry off the wheel caps, and loosen the hub nuts.
2. Jack up the front axle housing, and support the housing with stands.
3. Remove the hub nuts, and remove the wheels.
4. Remove the bolts and disconnect the front propeller shaft from the universal joint flange on the differential.
5. Drain the differential gear lubricant.
6. Remove the axle outer shaft flange cap, and then remove the shaft snap ring on the outer shaft.
7. Remove the axle outer shaft flange retaining bolts, and remove the axle outer shaft flange to screw in the two service bolts into the shaft flange alternately.
8. Straighten the lock washer, and remove the front wheel adjusting nuts with the Front Wheel Adjusting Nut Wrench 09607-60010.
9. Remove the brake drum together with the front axle hub.

10. Cut and remove the lock wire, and remove the bolts retaining the brake backing plate onto the steering knuckle without removing the brake flexible hose connection, then place the brake backing plate onto the front spring.
  11. Remove the steering knuckle spindle with the gasket from the steering knuckle, and then remove the outer shaft, front drive ball joint and the front axle inner shaft.
  12. Remove the nuts retaining the differential carrier onto the front axle housing, and remove the differential carrier assembly.
1. When installing, all gaskets and lock washers should be replaced.
  2. To prevent oil leak, apply liquid sealer onto the differential carrier gasket.
  3. The tightening torque of the differential carrier retaining nuts should be 4.0 ~ 5.5 m·kg (29 ~ 40 ft·lb).
  4. For adjustment of the front axle hub bearing, refer to Assembly & Installation (paragraph 11) on page 5-17.
  5. Refill the axle housing with hypoid gear lubricant up-to the filler hole. Use grade SAE 90. The capacity is 2.5 liters (2.6 US qts., 2.2 Imp. qts).

Installation

Follow the removal procedures in the reverse order.

\* \* \* \* \*

FRONT SUSPENSION

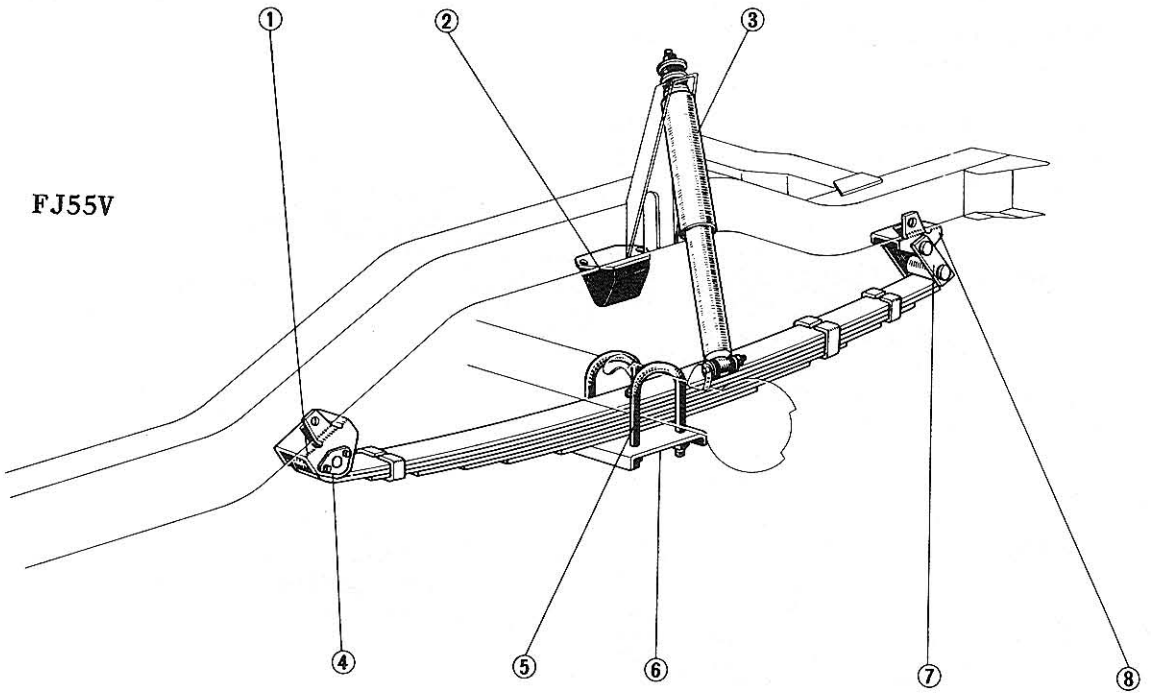

FJ40

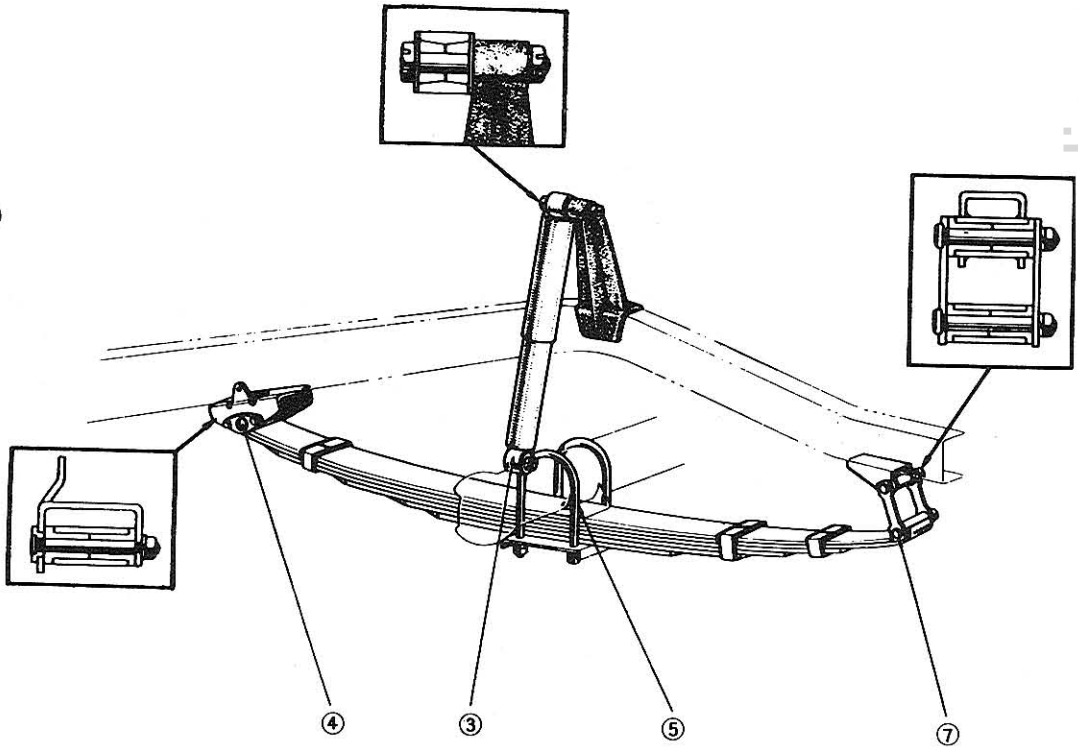

- 1. Spring bracket
- 2. Front spring bumper
- 3. Shock absorber
- 4. Spring bracket pin

- 5. U-bolt
- 6. Spring U-bolt seat
- 7. Spring shackle
- 8. Spring bracket

Fig.5-46 Front Suspension Components

cardiagn.com

Removal

1. Pry off the wheel cap, and loosen the hub nuts.
2. Jack up the front end of the vehicle and place stands under the frame and under the front axle housing.
3. Remove the hub nuts, and remove the wheel.
4. Remove the nuts, cushion, and the cushion retainer, then disconnect the shock absorber upper end from the bracket.
5. Remove the cotter pin and the nut at lower end of the shock absorber and then remove the shock absorber.
6. Loosen and remove the U-bolt nuts, and remove the U-bolt seat and the U-bolts.
7. Adjust the axle housing height with a jack until the weight is off the spring.  
Remove the nuts, and take out the spring shackle inner plate.  
Next, pry the spring shackle with a suitable bar, and remove the spring shackle and the rubber bushings.

8. Remove the two bolts retaining the spring bracket pin onto the spring bracket.

Be careful and drive out the spring bracket pin, then remove the front spring.

Remove the rubber bushings from the spring.

Inspection & Repair

Refer to Rear Suspension on page 4-21.

Installation

Follow the removal procedures in the reverse order.

Caution:

1. Make sure that the spring center bolt head is properly positioned in the hole provided in the spring seat on the axle housing.

2. The nuts on the spring shackle and the spring bracket pin must be tightened firmly after applying weight on the spring.

3. Tightening torque should be as follows:

U-bolt nuts:

6.9 ~ 9.7 m-kG (50 ~ 70 ft-lb)

Spring shackle & spring bracket pin nut:

5.0 ~ 8.0 m-kG (36 ~ 58 ft-lb)

\* \* \* \* \*