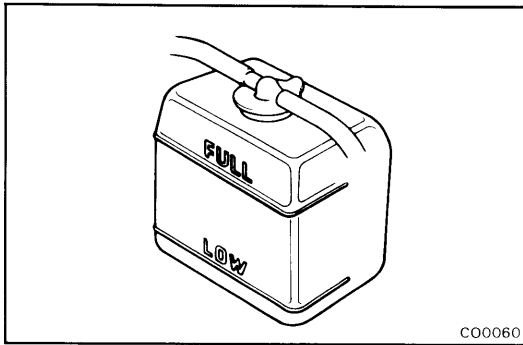

COOLING SYSTEM

	Page
TROUBLESHOOTING	CO-2
CHECK AND REPLACEMENT OF ENGINE COOLANT	CO-3
WATER PUMP	CO-4
THERMOSTAT	CO-6
RADIATOR	CO-7

TROUBLESHOOTING

Problem	Possible cause	Remedy	Page
Engine overheats	Fan belt loose or missing	Adjust or replace belt	CH-3
	Dirt, leaves or insects on radiator or condenser	Clean radiator or condenser	CO-7
	Hoses, water pump, thermostat housing, radiator, heater, core plugs or head gasket leakage	Repair as necessary	
	Thermostat faulty	Check thermostat	CO-6
	Ignition timing retarded	Adjust timing	IG-14
	Fluid coupling faulty	Replace fluid coupling	CO-4
	Radiator hose plugged or rotted	Replace hose	
	Water pump faulty	Replace water pump	CO-4
	Radiator plugged or cap faulty	Check radiator	CO-7
Cylinder head or block cracked or plugged	Repair as necessary		

NOTE: If the engine tends to overheat, removal of the thermostat will adversely effect cooling efficiency.



C00060

CHECK AND REPLACEMENT OF ENGINE COOLANT

1. CHECK ENGINE COOLANT LEVEL AT RESERVE TANK

The coolant level should be between the "LOW" and "FULL" lines.

If low, check for leaks and add coolant up to the "FULL" line.

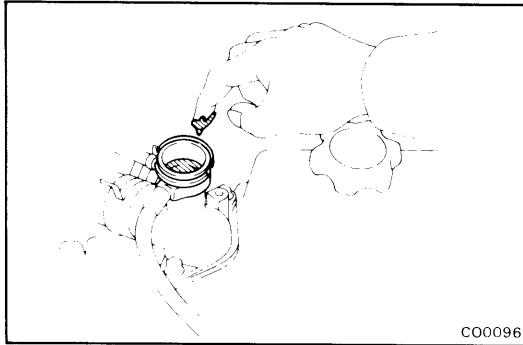

C00096

2. CHECK ENGINE COOLANT QUALITY

There should not be any excessive deposits of rust or scales around the radiator cap or radiator filler hole, and the coolant should be free from oil.

If excessively dirty, replace the coolant.

3. REPLACE ENGINE COOLANT

- (a) Remove the radiator cap or water outlet cap.
- (b) Drain the coolant from the radiator and engine drain cocks. (Engine drain cock is at left front of engine block.)
- (c) Close the drain cocks.
- (d) Fill the system with coolant.

Use a good brand of ethylene-glycol base coolant, mixed according to the manufacturer's directions.

Coolant capacity (w/H eater):

2WD	w/o Rear heater	7.9 liters (8.3 US qts, 7.0 Imp. qts)
	w/ Rear heater	8.4 liters (8.9 US qts, 7.4 Imp. qts)
4WD	w/o Rear heater	7.0 liters (7.4 US qts, 6.2 Imp. qts)
	w/ Rear heater	7.5 liters (7.9 US qts, 6.6 Imp. qts)

- (e) Install the radiator cap (water outlet cap).
- (f) Start the engine and check for leaks.
- (g) Recheck the coolant level and refill as necessary.

WATER PUMP COMPONENTS

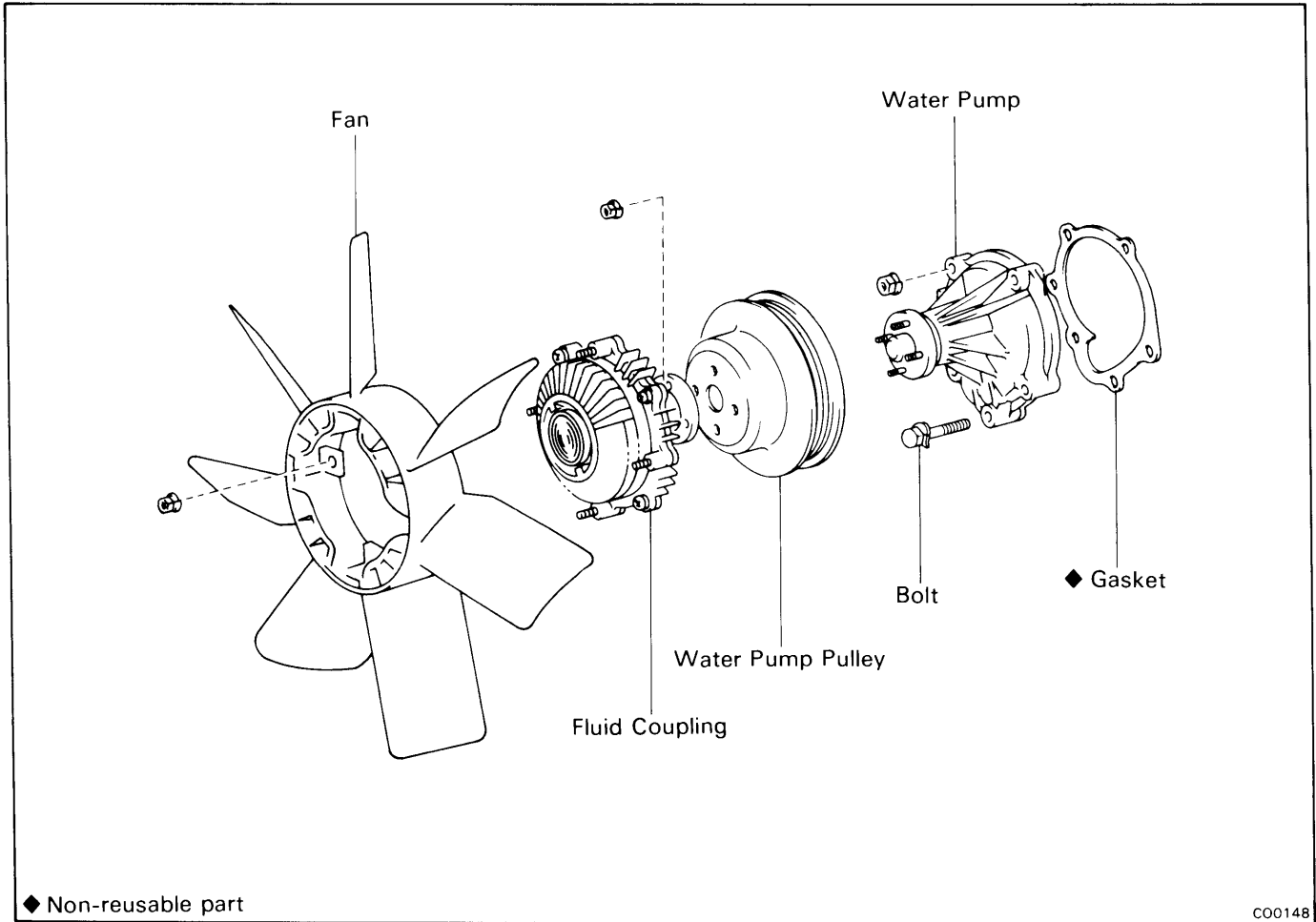

REMOVAL OF WATER PUMP

1. DRAIN COOLANT (See page CO-3)
2. REMOVE DRIVE BELT

3. REMOVE FAN AND WATER PUMP PULLEY

Remove the four nuts holding the fluid coupling to the pulley seat, and remove the fan and fluid coupling assembly and the pump pulley.

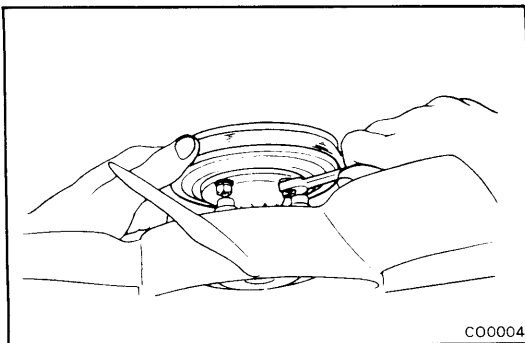

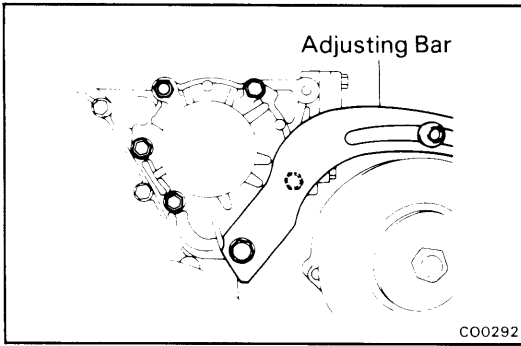

4. REMOVE WATER PUMP

- (a) Remove the bolt and disconnect the drive belt adjusting bar from the water pump.
- (b) Remove the nut, four bolts, water pump and gasket.

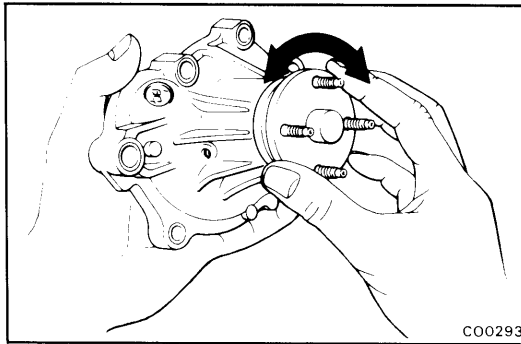

INSPECTION OF WATER PUMP COMPONENTS

1. INSPECT WATER PUMP

Turn the pulley seat and check that the water pump bearing moves smoothly and quietly.

If necessary, replace the water pump.

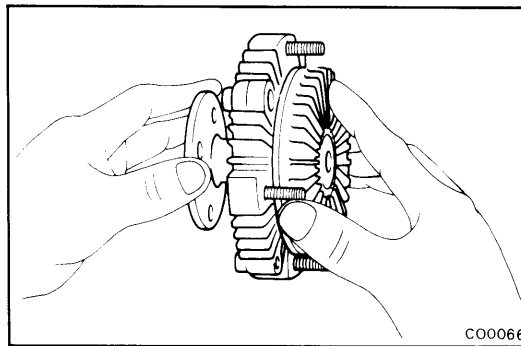

2. INSPECT FLUID COUPLING

Check the fluid coupling for damage and silicon oil leakage.

If necessary, replace the fluid coupling.

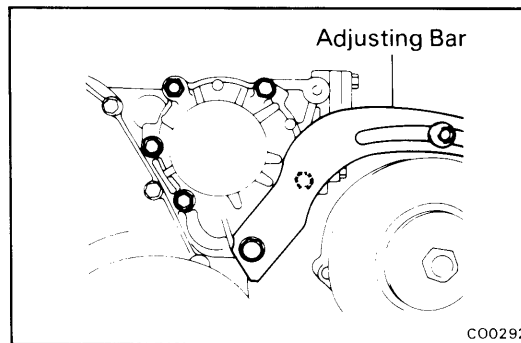

INSTALLATION OF WATER PUMP

(See page CO-4)

1. INSTALL WATER PUMP

Place a new water pump gasket to the timing chain case and install the water pump and drive belt adjusting bar with the nut and five bolts.

Torque:

Water pump	185 kg-cm
	(13 ft-lb, 18 N·m)
Adjusting bar	400 kg-cm
	(29 ft-lb, 39 N·m)

2. INSTALL WATER PUMP PULLEY AND FAN

Install the pump pulley and the fluid coupling and fan assembly with the four nuts.

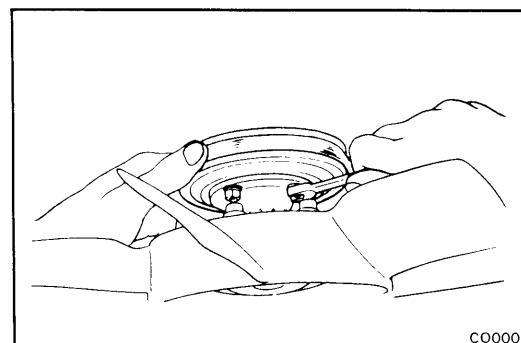

3. **INSTALL AND ADJUST DRIVE BELT**
(See page CH-13)
4. **REFILL WITH COOLANT** (See page CO-3)
5. **START ENGINE AND CHECK FOR LEAKS**

THERMOSTAT

REMOVAL OF THERMOSTAT

1. **DRAIN COOLANT** (See page CO-3)
2. **DISCONNECT RADIATOR OUTLET HOSE FROM WATER INLET**
3. **REMOVE WATER INLET AND THERMOSTAT**

Remove the two nuts, water inlet, gasket and thermostat from the timing chain case.

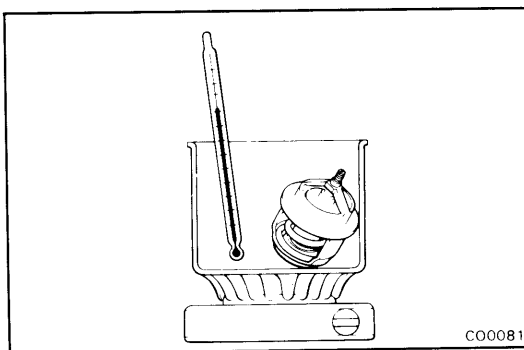
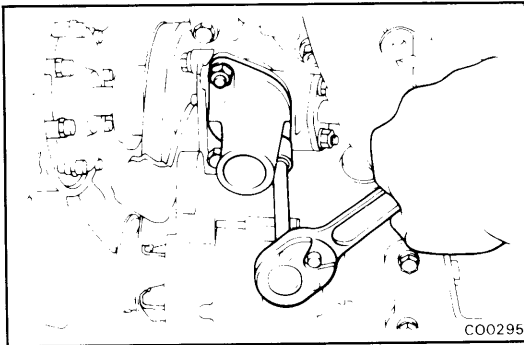

INSPECTION OF THERMOSTAT

NOTE: The thermostat is numbered according to the valve opening temperature.

- (a) Immerse the thermostat in water and heat the water gradually.

- (b) Check the valve opening temperature and valve lift.

If the valve opening temperature and valve lift are not within the following specifications, replace the thermostat.

Valve opening temperature:

80 – 84°C (176 – 183°F)

Valve lift:

8 mm (0.31 in.) or more at 95°C (203°F)

- (c) Check that the valve spring is tight when the thermostat is fully closed. Replace as necessary.

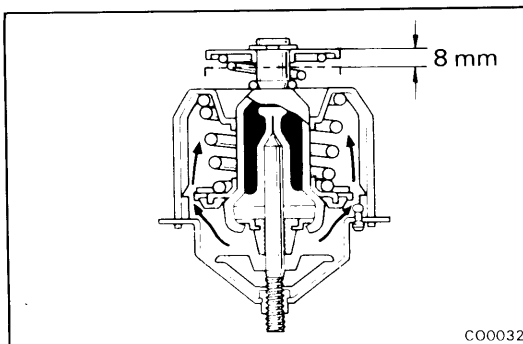

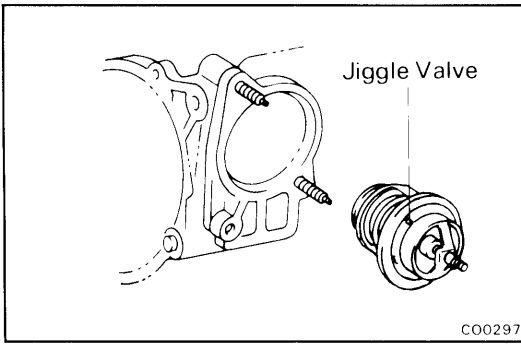

INSTALLATION OF THERMOSTAT

1. INSTALL THERMOSTAT AND WATER INLET

- (a) Install a new gasket to the thermostat and place the thermostat with the jiggle valve at the upper left as shown.

- (b) Install the water inlet with the two nuts.

Torque: 120 kg-cm (9 ft-lb, 12 N·m)

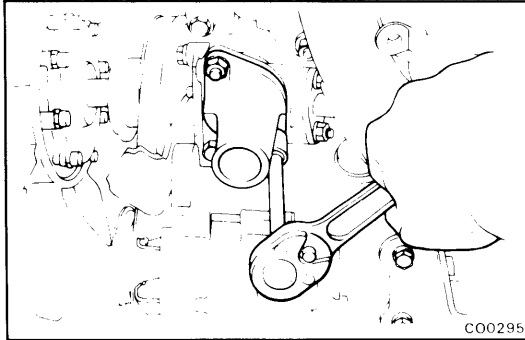

2. CONNECT RADIATOR OUTLET HOSE TO WATER INLET

3. REFILL WITH COOLANT (See page CO-3)

4. START ENGINE AND CHECK FOR LEAKS

RADIATOR

CLEANING OF RADIATOR

Using water or a steam cleaner, remove any mud and dirt from the radiator core.

CAUTION: If using a high pressure type cleaner, be careful not to deform the fins of the radiator core. If the cleaner nozzle pressure is 30 – 35 kg/cm² (427 – 498 psi, 2,492 – 3,432 kPa), keep a distance of at least 40 – 50 cm (15.75 – 19.69 in.) between the radiator core and cleaner nozzle.

INSPECTION OF RADIATOR

1. INSPECT WATER OUTLET CAP

Using a radiator cap tester, pump the tester until the relief valve opens. Check that the valve opens between 0.75 kg/cm² (10.7 psi, 74 kPa) and 1.05 kg/cm² (14.9 psi, 103 kPa).

Check that the pressure does not drop rapidly when pressure on the cap is below 0.6 kg/cm² (8.5 psi, 59 kPa).

If either check is not within limits, replace the cap.

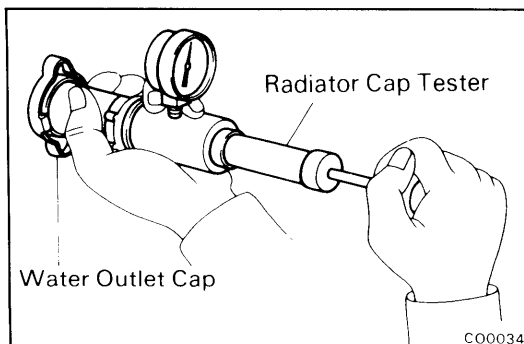

2. INSPECT COOLING SYSTEM FOR LEAKS

- Fill the radiator with coolant and attach a pressure tester.
- Warm up the engine.
- Pump it to 1.2 kg/cm² (17 psi, 118 kPa), check that pressure does not drop.

If the pressure drops, check for leaks from the hoses, radiator or water pump. If no external leaks are found, check the heater core, cylinder block and head.

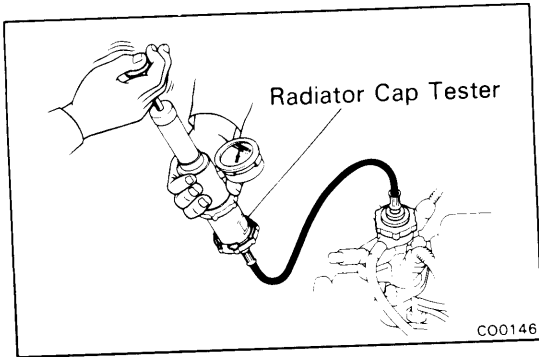

REMOVAL OF RADIATOR

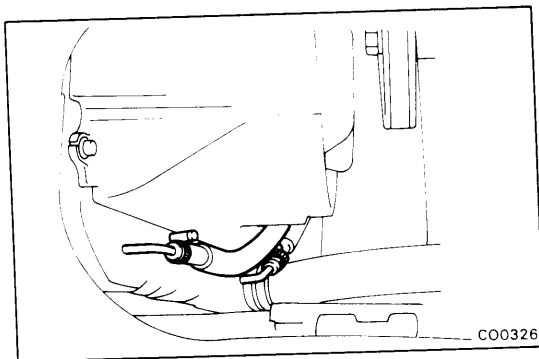
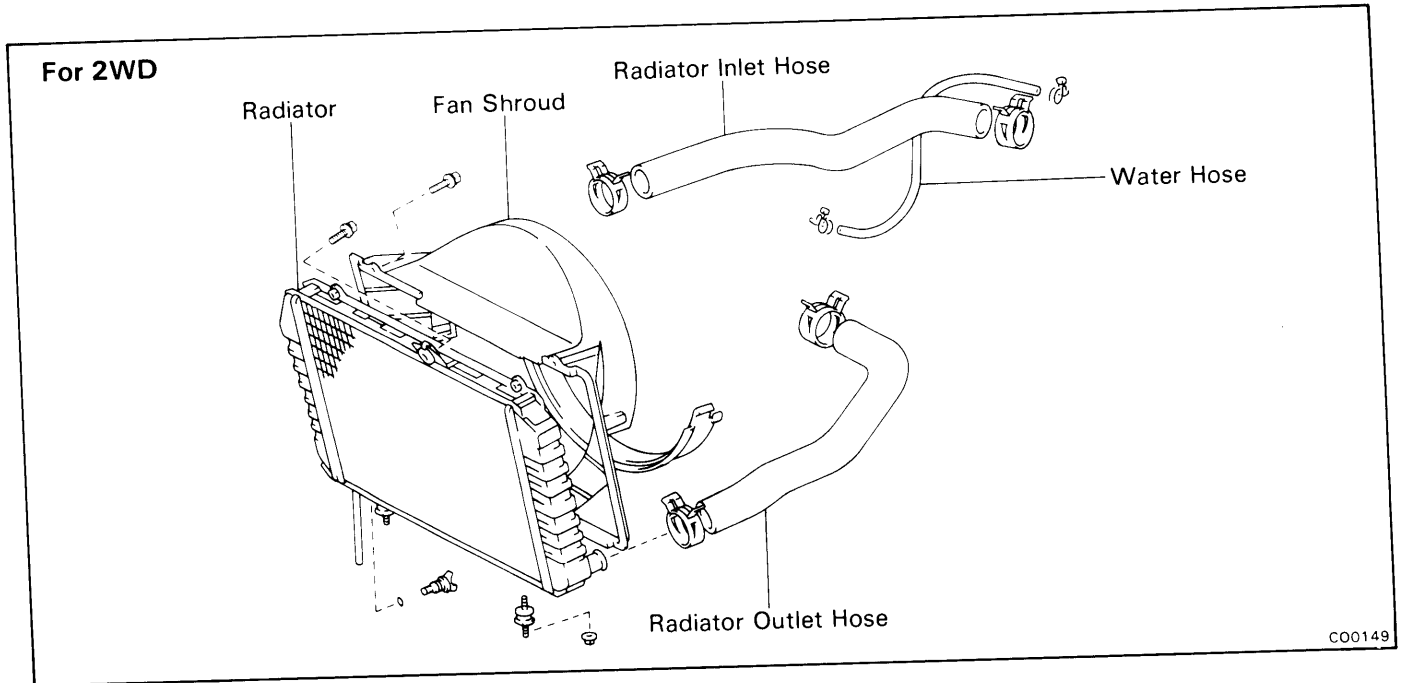

1. DRAIN COOLANT (See page CO-4)

2. [A/T] DISCONNECT OIL COOLER HOSES

- Remove and lay the washer fluid tank to one side without disconnecting the hoses.
- Disconnect the two cooler hoses from the radiator.

NOTE:

- Be careful as some oil will leak out. Catch it in a suitable container.
- Plug the hose to prevent oil from escaping.

3. REMOVE FAN SHROUD

4. DISCONNECT RADIATOR HOSES AND COOLANT RESERVOIR HOSE FROM RADIATOR

5. REMOVE RADIATOR UPPER BOLT

6. RAISE VEHICLE

CAUTION: Be sure the vehicle is securely supported.

7. REMOVE ENGINE UNDER COVER**8. REMOVE RADIATOR**

Remove the nuts and pull out the radiator from the frame.

INSTALLATION OF RADIATOR

(See page CO-8)

1. INSTALL RADIATOR**2. INSTALL ENGINE UNDER COVER****3. LOWER VEHICLE****4. INSTALL RADIATOR UPPER BOLT****5. CONNECT RADIATOR HOSES AND COOLANT RESERVOIR HOSE TO RADIATOR****6. INSTALL FAN SHROUD****7. [A/T]
CONNECT OIL COOLER HOSES****8. REFILL WITH COOLANT (See page CO-3)****9. START ENGINE AND CHECK FOR LEAKS****10. [A/T]
CHECK AUTOMATIC TRANSMISSION FLUID LEVEL**

Fluid type: ATF DEXRON® II

CAUTION: Do not overfill.

