

BRAKE

	Page
CUTAWAY VIEW	9-2
ADJUSTMENT	9-6
BRAKE PEDAL	9-10
BRAKE HOSE & TUBE	9-12
MASTER CYLINDER	9-15
BRAKE BOOSTER	9-28
VACUUM PUMP	9-64
FRONT BRAKE	9-71
REAR BRAKE	9-90
PARKING BRAKE	9-101
P & B VALVE (PROPORTIONING & BYPASS VALVE)	9-109
LSPV (LOAD SENSING PROPORTIONING VALVE)	9-111

CUTAWAY VIEW

Fig. 9-1

**TANDEM MASTER CYLINDER
(For Disc Brake)**

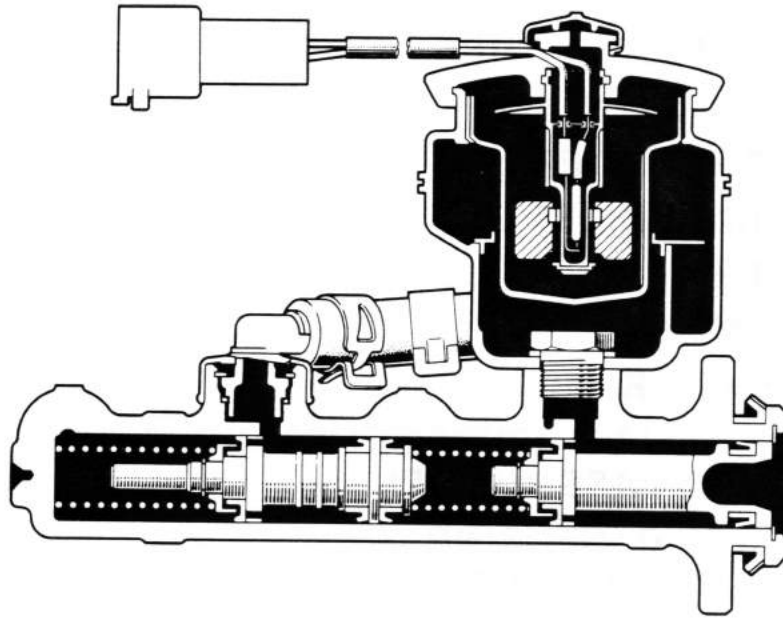

**TANDEM MASTER CYLINDER
(For Drum Brake)**

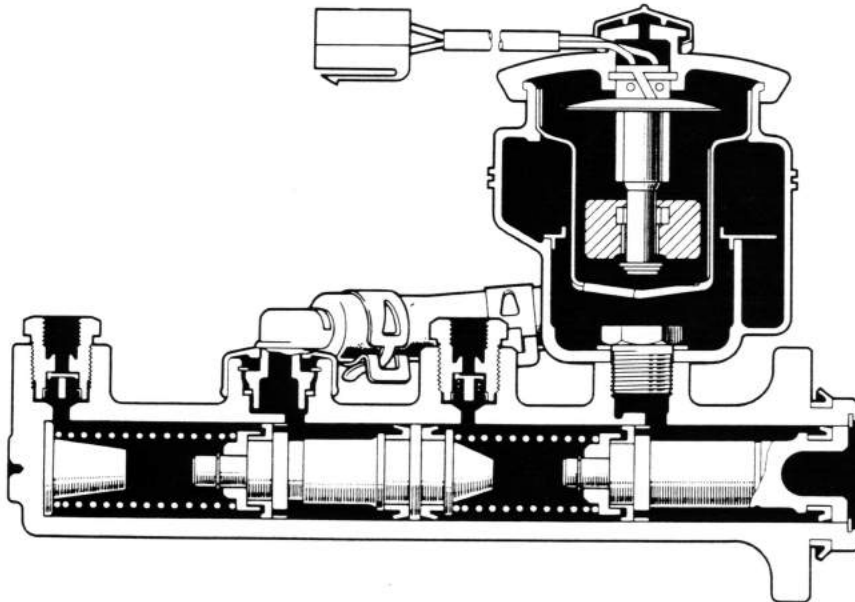
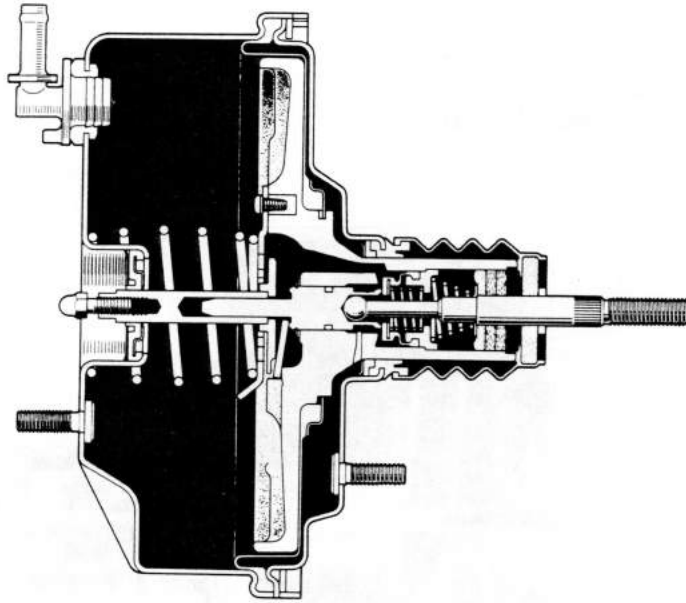

Fig. 9-2

**BRAKE BOOSTER
(7.5 in. For Drum Brake)**



**BRAKE BOOSTER
(9.0 in. For Drum & Disc Brake)**

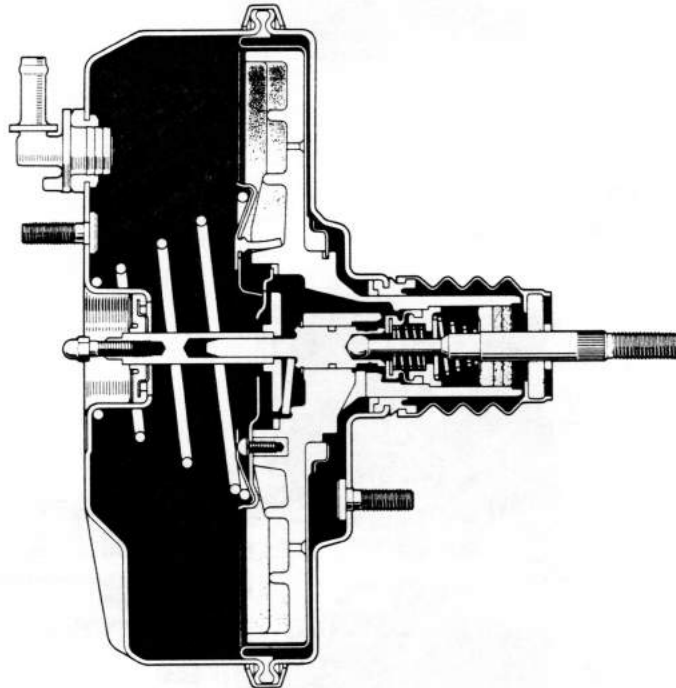
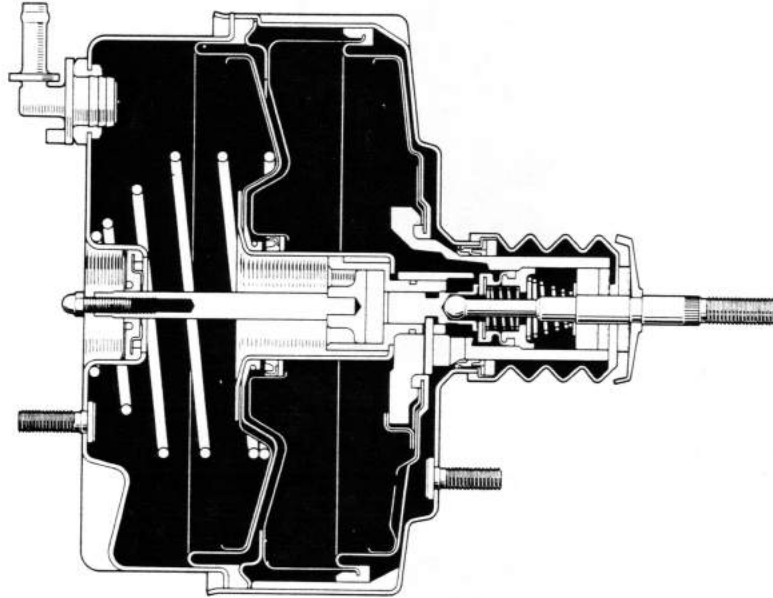

Fig. 9-3

BRAKE BOOSTER
(7.5 in. Tandem Type : AISIN)



BRAKE BOOSTER
(7.5 in. Tandem Type : JKC)

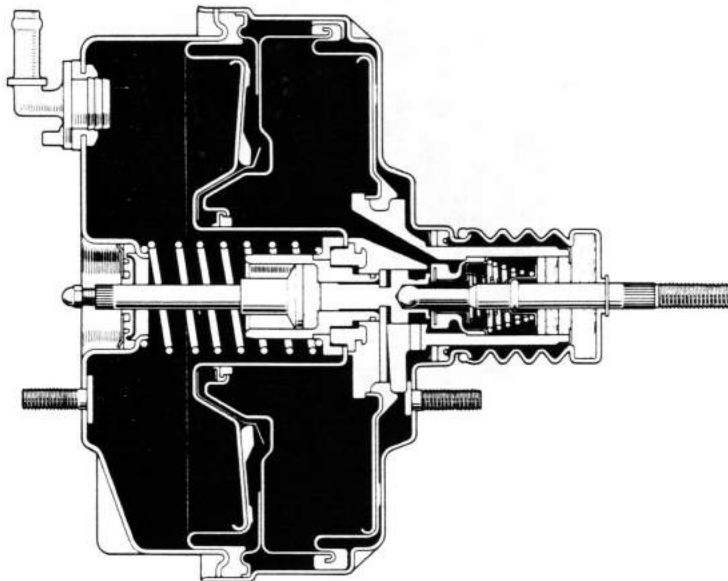
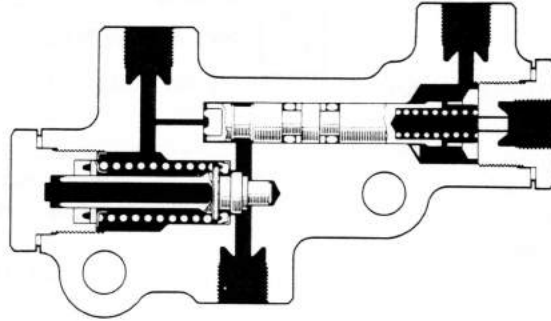

Fig. 9-4

P & B VALVE



LSPV

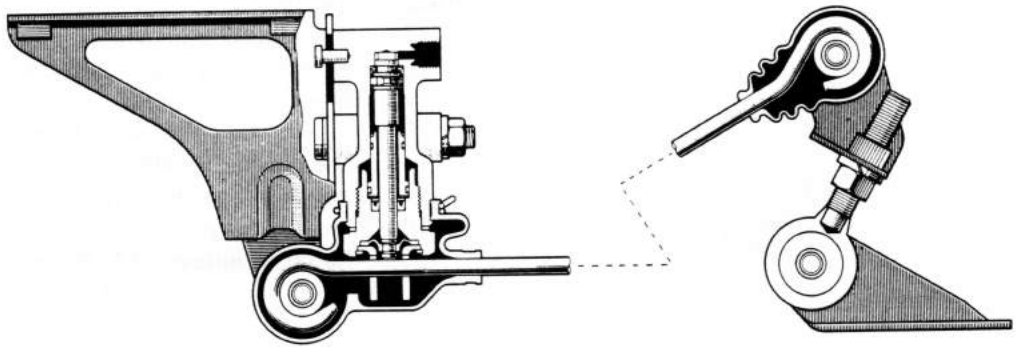
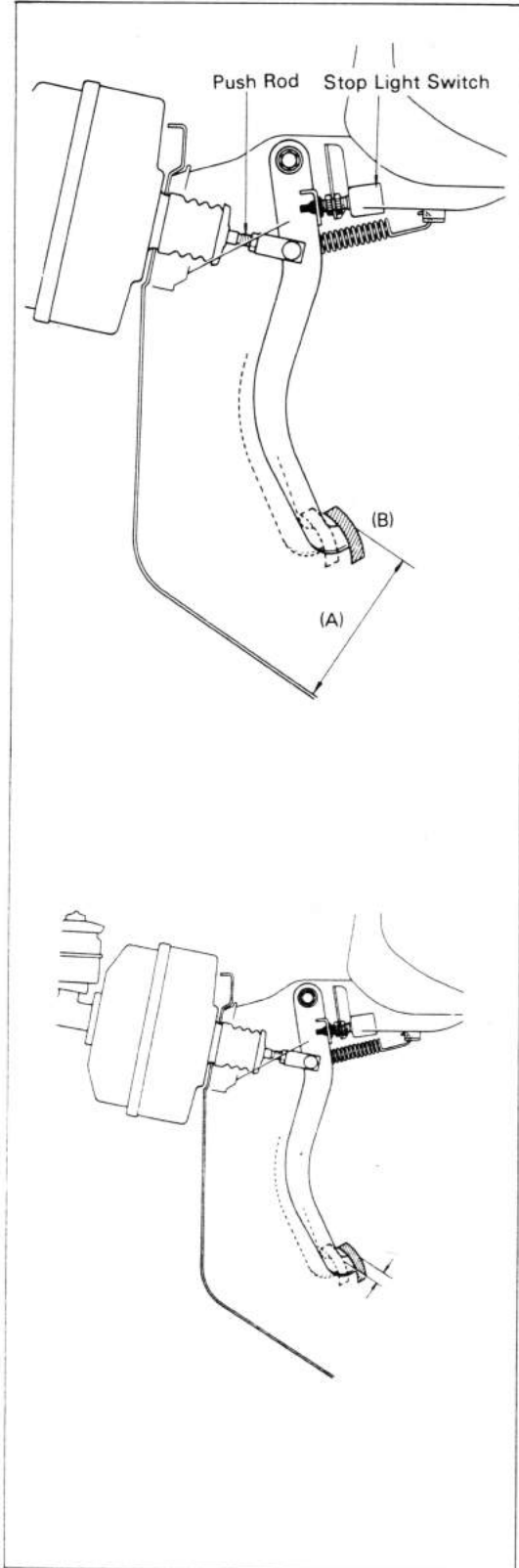

Fig. 9-5



ADJUSTMENT

BRAKE PEDAL

Pedal Height (A)

1. Measure the pedal height between the pedal top and asphalt sheet.

Pedal height:

**FJ, BJ, HJ 4 _ series 215 mm
(8.46 in.)**

**FJ, BJ, HJ 6 _ series 192 mm
(7.55 in.)**

2. Adjust the pedal height.
 - (1) Sufficiently loosen the stop light switch.
 - (2) Adjust the pedal height by turning the push rod.
 - (3) Return the stop light switch until its body lightly contacts the pedal stopper.

Pedal Freeplay

1. Stop the engine and depress the brake pedal several times until there is no more vacuum left in the booster.
2. Press down the pedal with fingers until initial resistance is felt. The amount of play sensed at this time should be within the specified range.

**Pedal freeplay: 3 – 6 mm
(0.12 – 0.24 in.)**

– Note –

1. If the pedal freeplay is not within the specified range, adjust the pedal height by the method described in Pedal Height so as to provide the proper amount of pedal freeplay.
2. The pedal freeplay is not the amount of stroke up to the time the booster piston starts to move.

Fig. 9-6

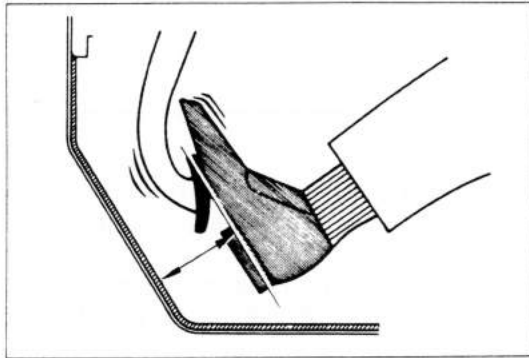

Fig. 9-7

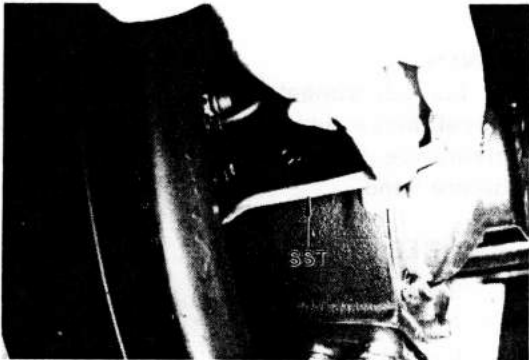

Fig. 9-8

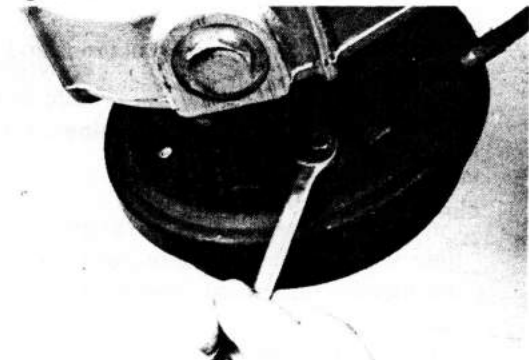
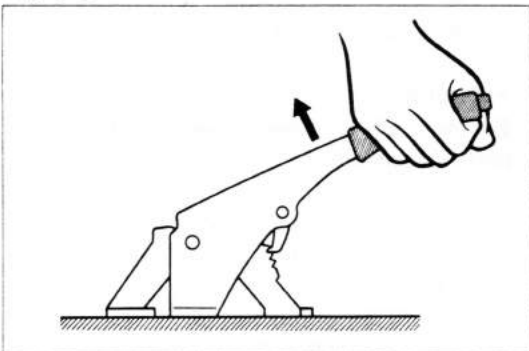

Fig. 9-9



SHOE CLEARANCE

Check The Pedal Reserve Distance

Depress the brake pedal and check the pedal reserve distance.

Pedal reserve distance:

Disc brake

FJ, BJ 40-42-43 series

More than 115 mm (4.53 in.)

FJ, BJ, HJ60 series

More than 105 mm (4.13 in.)

Drum brake

FJ, BJ 40-42-43 series

More than 110 mm (4.33 in.)

FJ, BJ, HJ 45-46-47-60 series

More than 100 mm (3.94 in.)

Adjust The Shoe Clearance

Front Brake

1. Jack up the vehicle so that the wheels turn freely.
2. Turn the wheel and spread the shoes by screwing the adjusting nut until the wheel locks with SST.
SST [09704-10010]
3. While pumping the pedal, close the shoes until the wheel turn freely.

The standard number of notches to be backed off : 5 notches

PARKING BRAKE

Center Brake Type

1. Turn the adjuster counterclockwise until the brake shoes are fully expanded.
2. Return the adjuster one notch.
3. Check the brake drums to see that the brakes are not dragging after pulling the parking brake lever all the way back and then releasing it.
If dragging, return the adjuster another notch.



Parking Brake Lever

1. Pull the parking brake lever and check its distance.

Parking brake lever distance:

FJ, BJ, HJ 60 series

7 - 9 clicks at 20 kg (44 lb)

FJ, BJ 40-42-43 series

8 - 10 clicks at 20kg (44 lb)

3 - 6 clicks at 25 kg (55 lb)

with center brake

Fig. 9-10

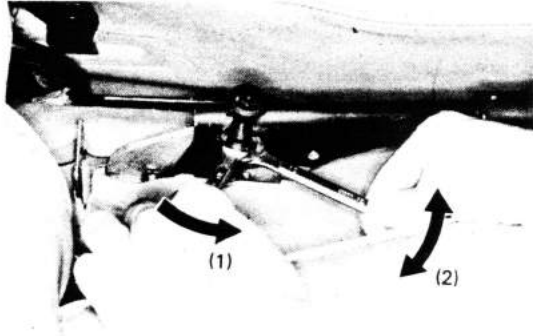

Fig. 9-11

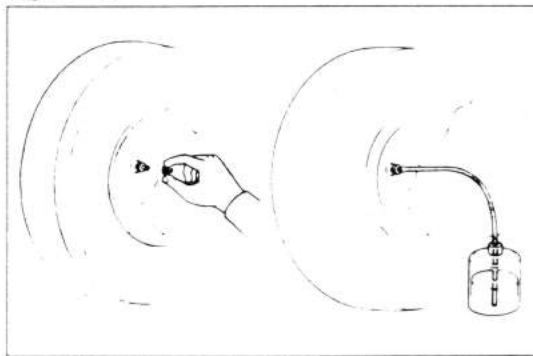

Fig. 9-12

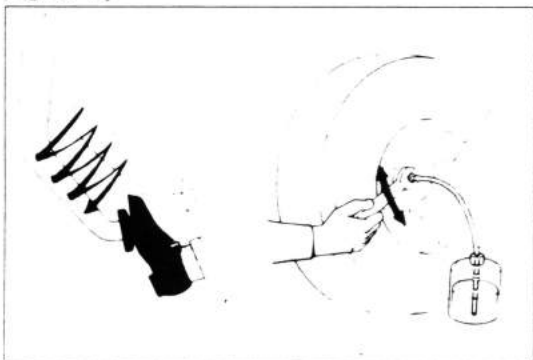
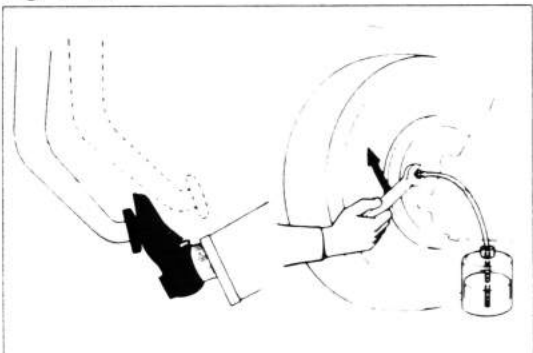

Fig. 9-13



2. If the parking brake lever does not have the specified travel, adjust parking brake cables.

- (1) Loosen the adjusting cap.
- (2) Adjust the amount of lever travel by turning the nut.
- (3) Fully tighten the adjusting cap by hand.

— Note —

In the adjustment of the parking brake travel, make sure that the rear brake shoe clearance has been correctly adjusted before hand.

AIR BLEEDING

1. Remove the bleeder plug cap. Attach a vinyl tube to the wheel cylinder bleeder plug and insert the other end into a container.

— Note —

1. **Begin bleeding air from the wheel cylinder with the longest hydraulic line.**
2. **Bleed air from the bypass pipe (with LSPV).**

2. Depress the brake pedal several times and then while holding it depressed, loosen the bleeder plug about one-third to one-half turn.
3. When the fluid pressure in the cylinder is almost depleted, retighten the plug.
4. Repeat this operation until there are no more air bubbles in the hydraulic line.

— Caution —

Do not allow brake fluid to remain on painted surface.

5. When the bubbles stop, depress and hold the brake pedal, and then tighten the bleeder plug.

Tightening torque:

**0.9 – 1.3 kg-m
(79 – 112 in.-lb)**

Fig. 9-14

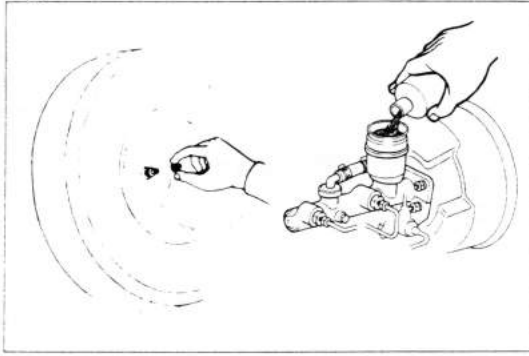

6. Attach the bleeder plug cap.
7. After bleeding, apply fluid pressure to the line and check for leakage.
8. Replenish the fluid in the reservoir to the specified level.

BRAKE PEDAL REMOVAL

Remove the parts in the numerical order shown in the figure.

Fig. 9-15

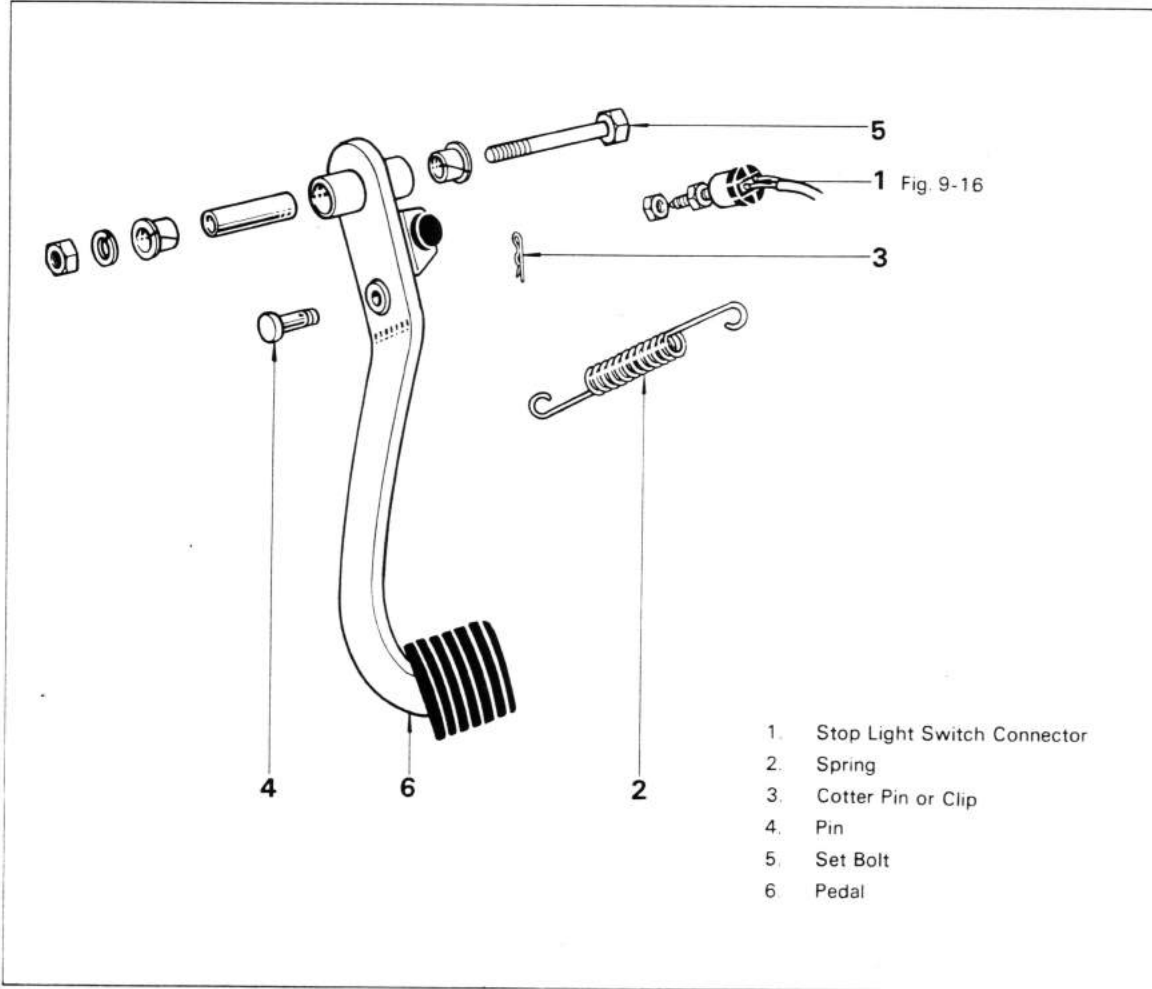
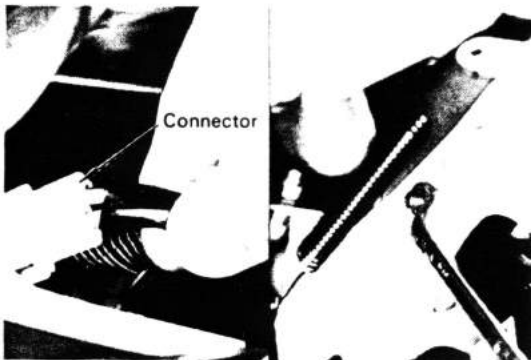

Fig. 9-16



Disconnect the stop light switch connector and remove the pedal.

Fig. 9-17

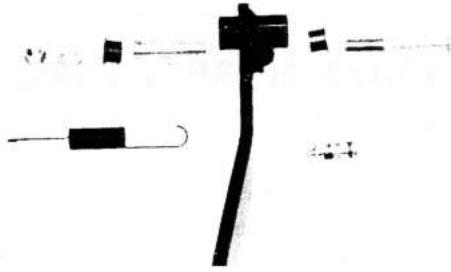

Fig. 9-18

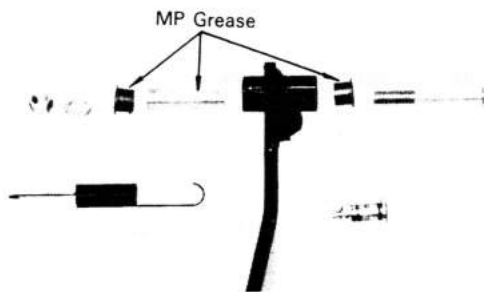

Fig. 9-19



Fig. 9-20

SEE
BRAKE PEDAL
ADJUSTMENT
SECTION
Fig. 9-5

**INSPECTION**

Inspect the removed parts for wear or damage, and replace parts if necessary.

**INSTALLATION**

1. Install in reverse sequence of removal.

– Note –

Coat the bushings with MP grease.



2. Install the bolt.

Tightening torque:

**3.0 – 4.5 kg-m
(22 – 32 ft-lb)**

3. Adjust the pedal height and play.

BRAKE HOSE & TUBE

REMOVAL

Remove the parts in the numerical order shown in the figure.

— Note —

Only servicing for the main components is described.

Fig. 9-21

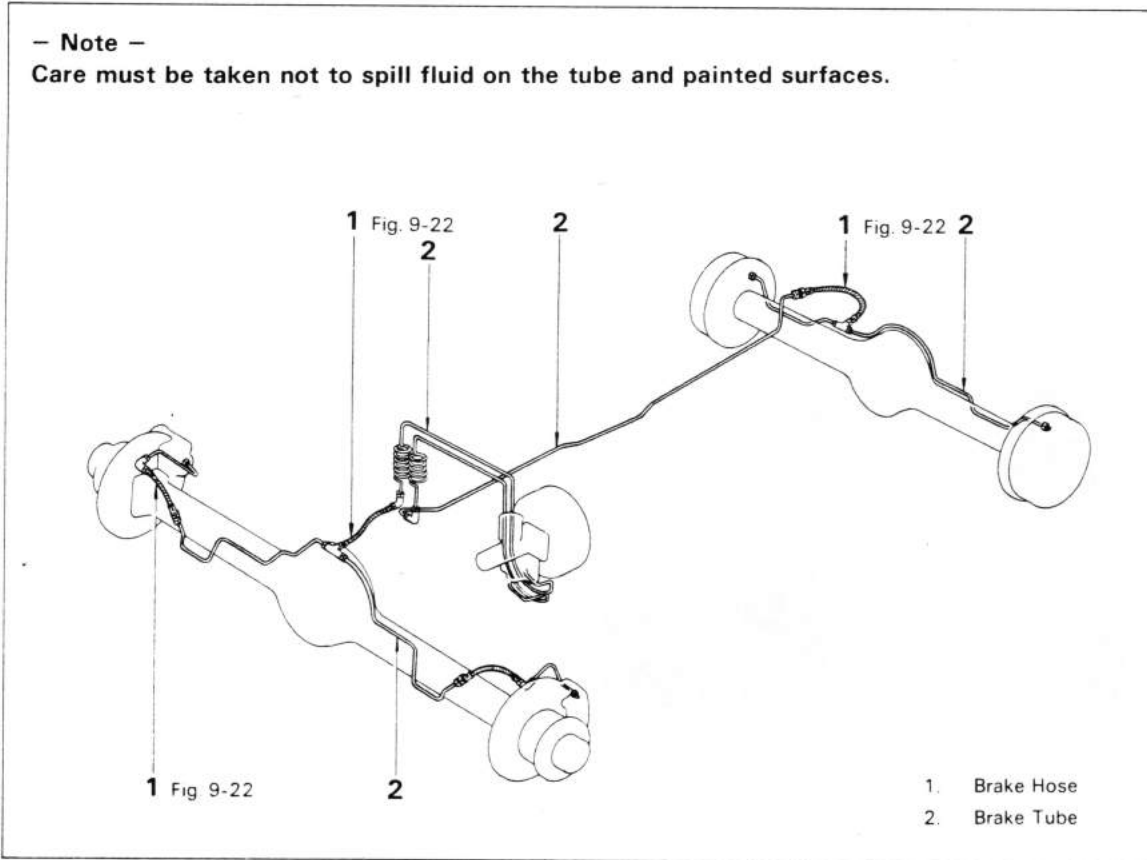
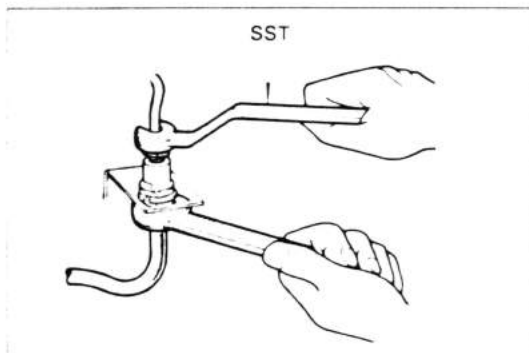
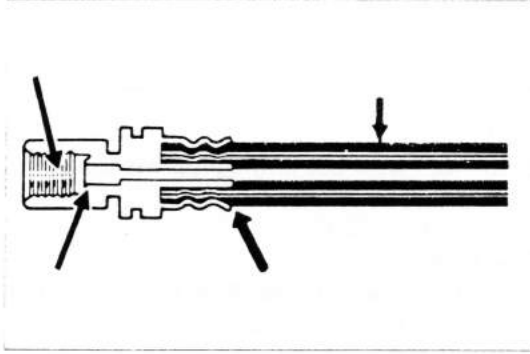

Fig. 9-22



Disconnect the hose and tube with a wrench and SST.
SST [09751-36011]

Fig. 9-23



INSPECTION

Brake Hose

1. Inspect the hose for damage, cracks or swelling.
2. Inspect the threads and tapered portion for damage.

Fig. 9-24

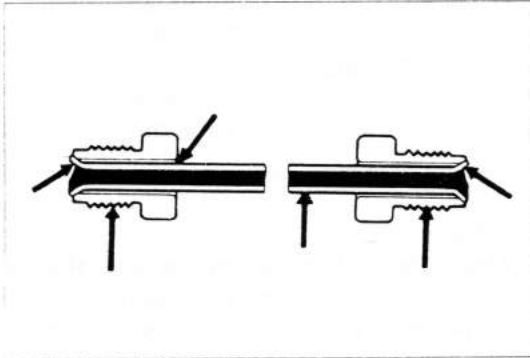

Brake Tube

1. Inspect the tube for damage, cracks, dents or corrosion.
2. Inspect the threads for damage.

INSTALLATION

Install the parts in the numerical order shown in the figure.

Fig. 9-25

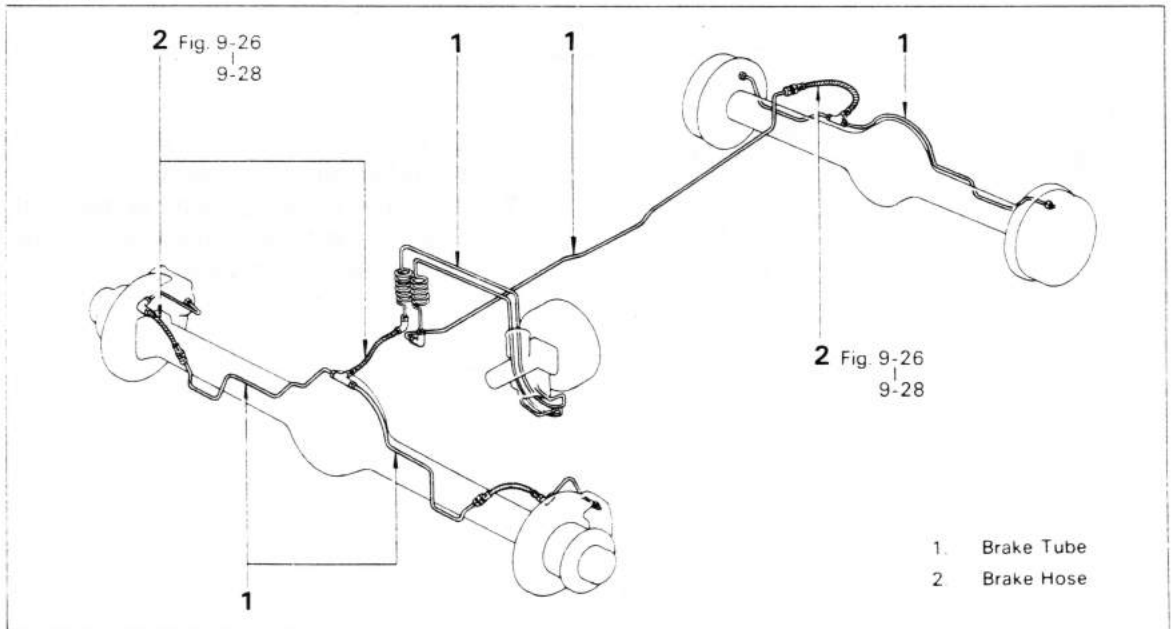

cardiagn.com

Fig. 9-26

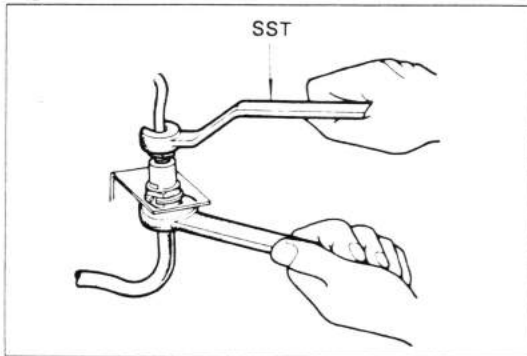

Connect the tubes to the proper places with a wrench and SST.

SST [09751-36011]

— Note —

All hoses should be free from excessive bending twisting or pulling.

Tightening torque:

Brak tube union nut

1.3 – 1.8 kg-m

(10 – 13 ft-lb)

Flexible hose

2.0 – 2.7 kg-m

(15 – 19 ft-lb)

Fig. 9-27

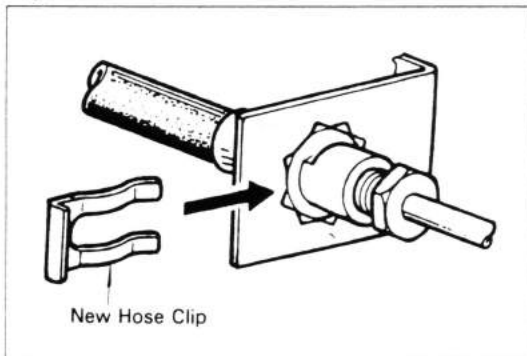

Install a new hose clip.

— Note —

After installation, check to see that all hoses and tubes have sufficient clearance to prevent contacting any sharp edges, moving components or the exhaust pipe.

Fig. 9-28

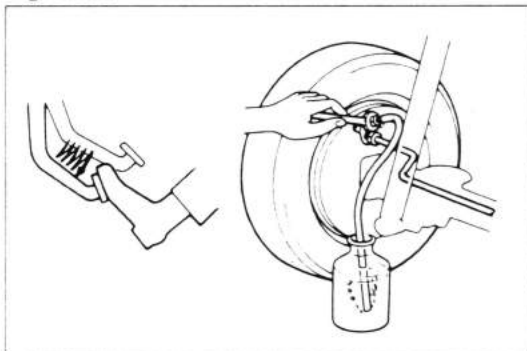

Bleed the air from the brake line.
(See Fig. 9-11 to 9-14)

— Note —

1. Care must be taken not to spill fluid on the tube and painted surface.
2. After the bleeding, depress the brake pedal strongly and check the connection for leaks or oozing.

MASTER CYLINDER**REMOVAL**

Remove the parts in the numerical order shown in the figure.

Fig. 9-29

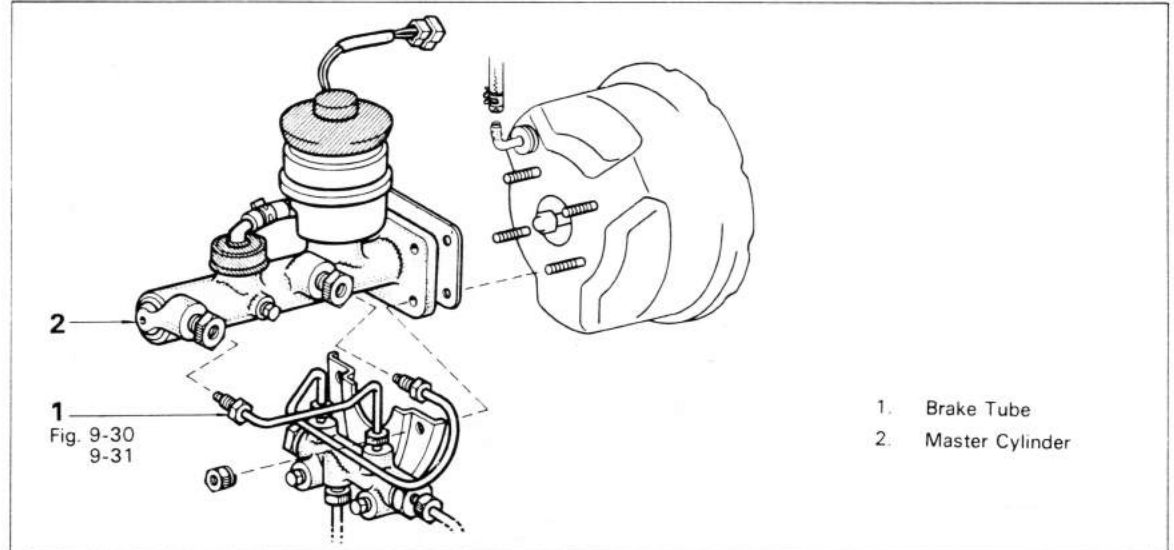
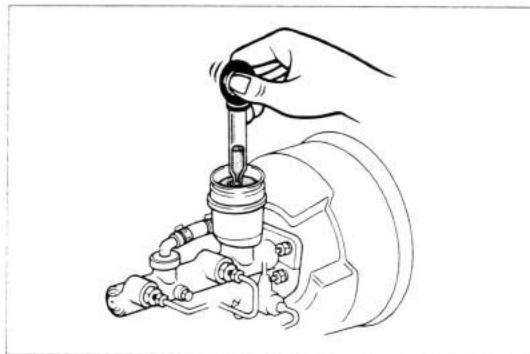
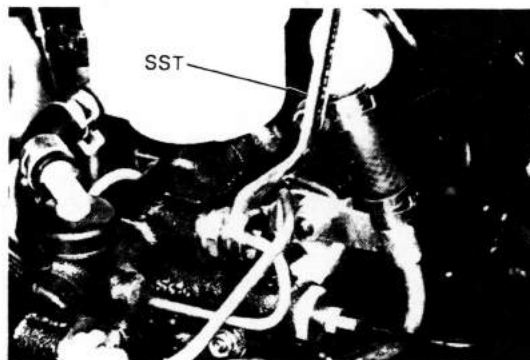

Fig. 9-30



Take out fluid with a syringe or such.

Fig. 9-31



Disconnect the brake tube from the master cylinder with SST.
SST [09751-36011]

— Note —

Do not allow brake fluid together painted surfaces.

DISASSEMBLY

Disassemble the parts in the numerical order shown in the figure.

Fig. 9-32

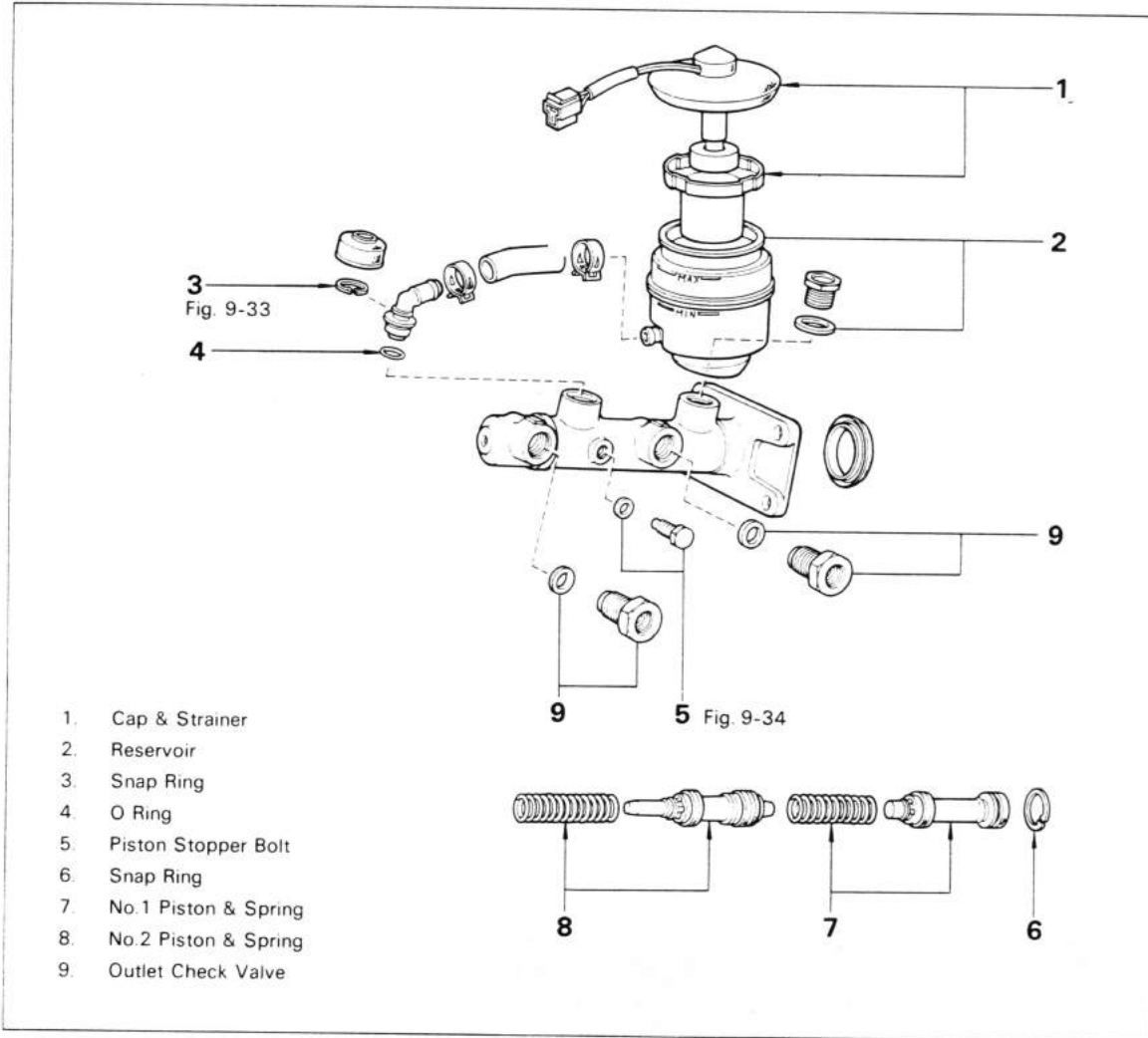

- 1. Cap & Strainer
- 2. Reservoir
- 3. Snap Ring
- 4. O Ring
- 5. Piston Stopper Bolt
- 6. Snap Ring
- 7. No. 1 Piston & Spring
- 8. No. 2 Piston & Spring
- 9. Outlet Check Valve

Fig. 9-33

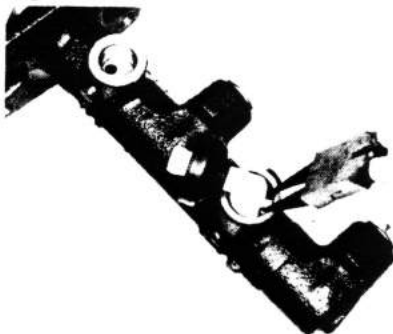

Remove the snap ring, and take out the elbow.

Fig. 9-34

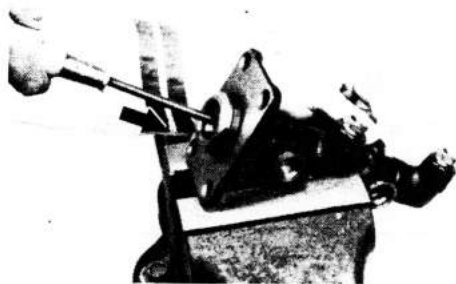

Remove the piston stopper bolt with the pistons pushed in all the way.

Fig. 9-35

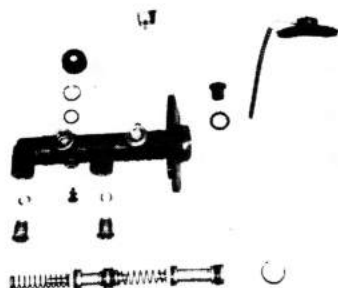
**INSPECTION**

Inspect the all disassembled parts for wear or damage, and replace parts if necessary.

— Note —

1. Wash the disassembled parts with brake fluid.
2. Do not reuse the piston cup.

Fig. 9-36

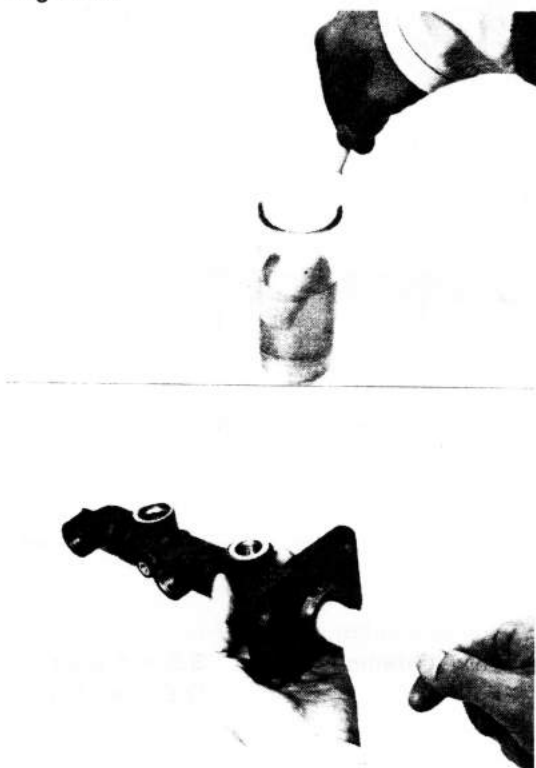
**MASTER CYLINDER INNER WALL CLEANING**

1. Use a thin wooden stick having soft white cloth wound on its tip and sook in the new brake fluid.
2. Insert the stick into the cylinder halfway and rotate to clean the inner wall.

— Note —

Do not push and pull the stick to clean the inner wall.

3. Fill the new brake fluid in the cylinder and shake to clean the inner wall.
4. Air blow to remove the fluid and dust in the master cylinder.
5. Make sure that there are no dust and scratch on the inner wall.

ASSEMBLY

Assemble the parts in the numerical order shown in the figure.

Fig. 9-37

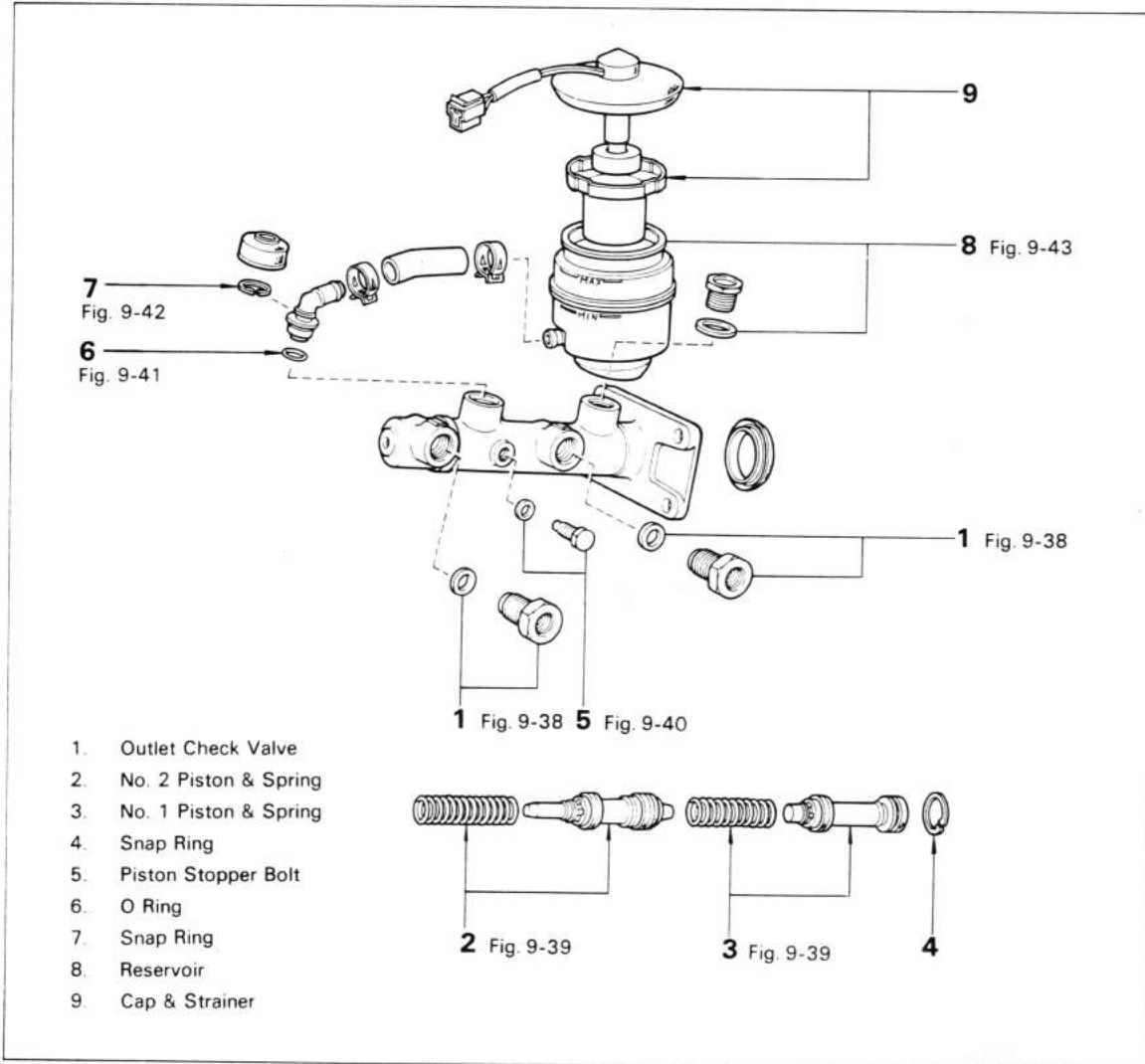

Fig. 9-38



Install the outlet check valve.

Tightening torque: 3.5 – 5.5 kg-m
(26 – 39 ft-lb)

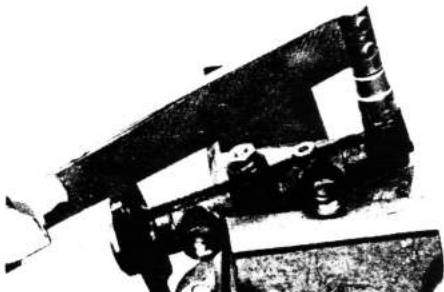
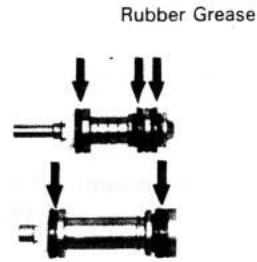

Fig. 9-39



— Note —
Before assembly, coat rubber grease on the parts indicated by arrows.

Fig. 9-40



Install the piston stopper bolt with pistons pushed in all the way.

Tightening torque: 0.8 – 1.5 kg-m
(70 – 130 in.-lb)

Fig. 9-41

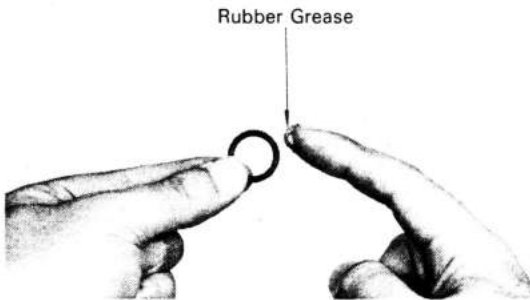

Apply rubber grease to the O ring and install the O ring to the elbow.

Fig. 9-42

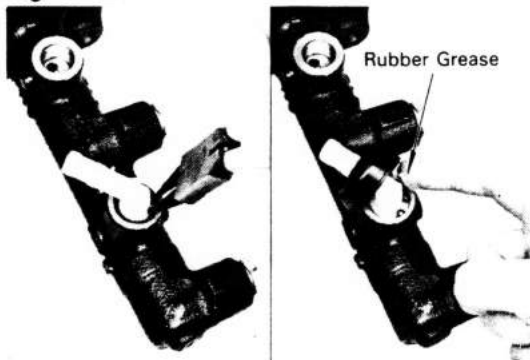

After assembling the snap ring, insert rubber grease between elbow and boots.

Fig. 9-43

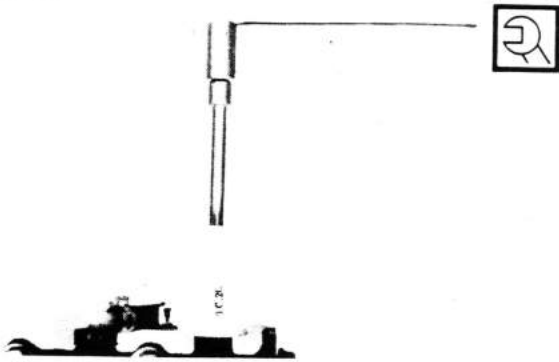

Tighten the reservoir set bolt

Tightening torque: 2.0 – 3.0 kg-m
(15 – 21 ft-lb)

– Note –

When tightening the reservoir tank, keep it
from turning.

DISASSEMBLY

Disassemble the parts in the numerical order shown in the figure.

Fig. 9-44

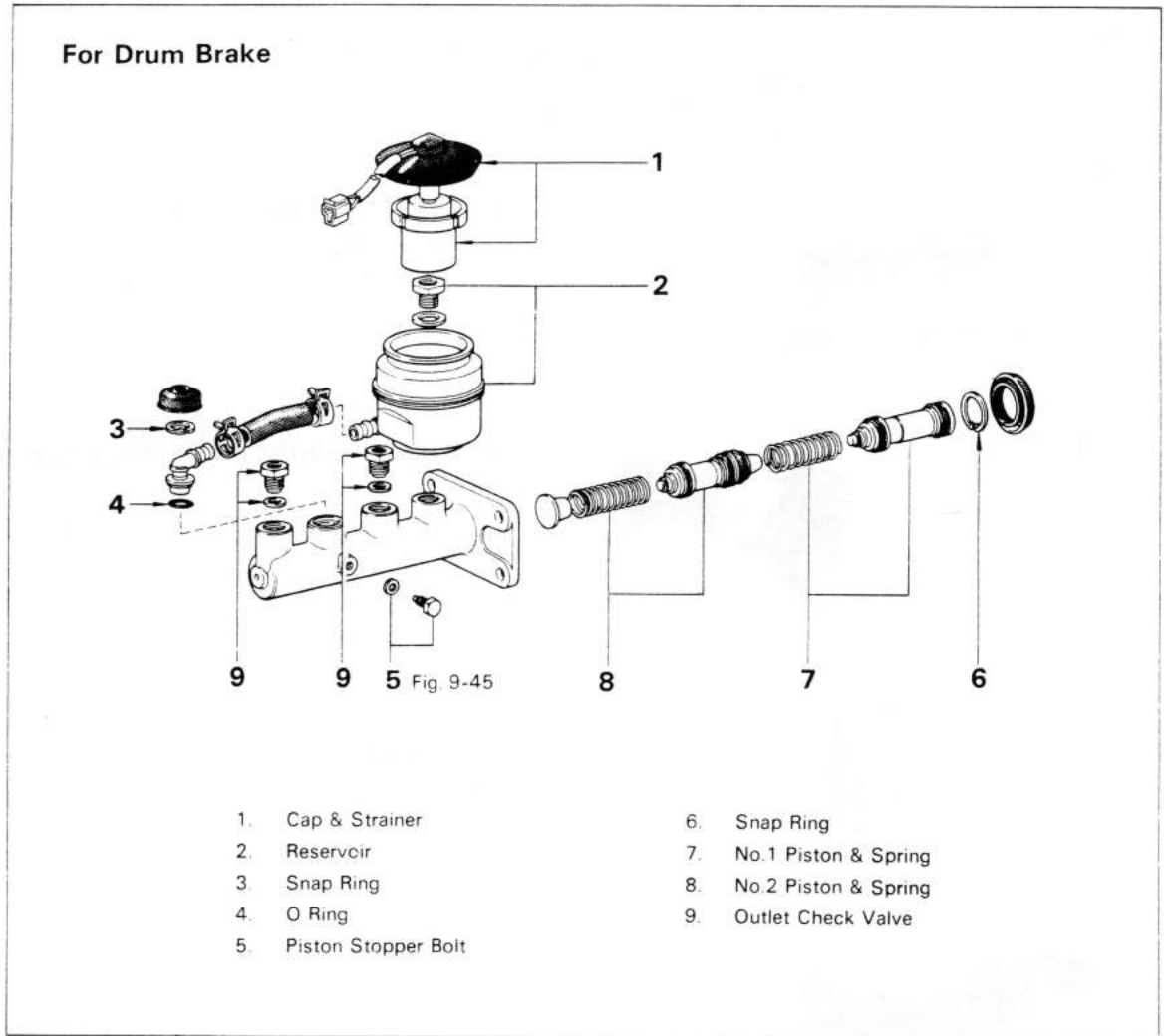
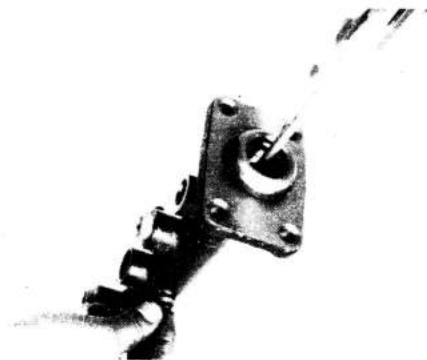
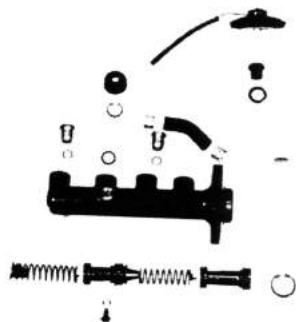

Fig. 9-45



Remove the piston stopper bolt with the pistons pushed in all the way.

Fig. 9-46

**INSPECTION**

Inspect the all disassembled parts for wear or damage, and replace parts if necessary.

— Note —

1. Wash the disassembled parts with brake fluid.
2. Do not reuse the piston cap.

Fig. 9-47

**MASTER CYLINDER INNER WALL CLEANING**

1. Use a thin wooden stick having soft white cloth wound on its tip and soak in the new brake fluid.
2. Insert the stick into the cylinder halfway and rotate to clean the inner wall.

— Note —

Do not push and pull the stick to clean the inner wall.

3. Fill the new brake fluid in the cylinder and shake to clean the inner wall.
4. Air blow to remove the fluid and dust in the master cylinder.
5. Make sure that there are no dust and scotch on the inner wall.

ASSEMBLY

Assemble the parts in the numerical order shown in the figure.

Fig. 9-48

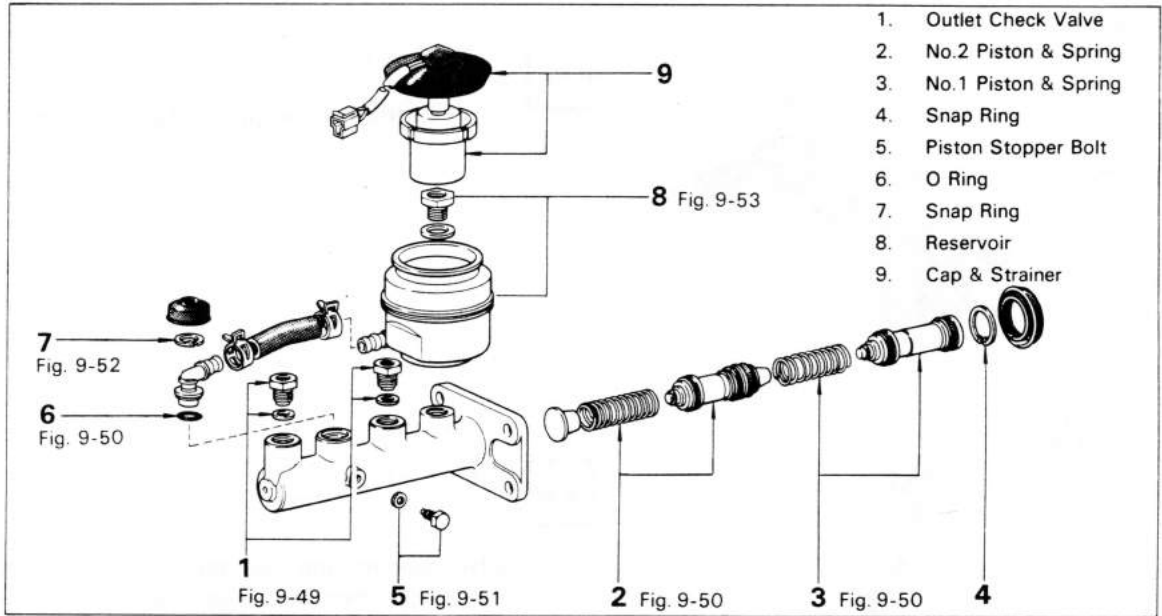
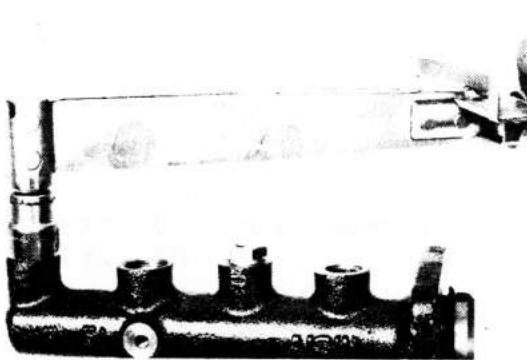

Fig. 9-49



Install the outlet check valve.

**Tightening torque: 3.5 – 5.5 kg-m
(26 – 39 ft-lb)**

Fig. 9-50

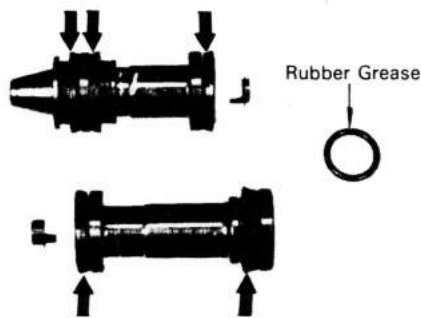

Before assembly, coat rubber grease on the parts indicated by arrows.

Fig. 9-51



Install the piston stopper bolt with pistons pushed in all the way

Tightening torque: 0.8 – 1.5 kg-m
(70 – 130 in.-lb)

Fig. 9-52

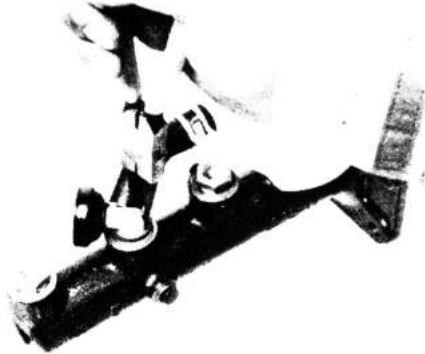

Push in the elbow and install the snap ring.

– Note –

After assembling the snap ring, insert rubber grease between elbow and boots.

Fig. 9-53

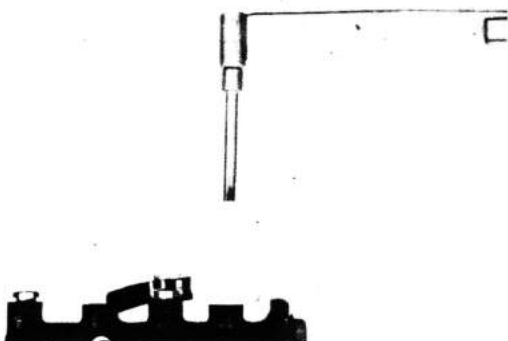

Install the master cylinder reservoir.

Tightening torque: 2.0 – 3.0 kg-m
(15 – 21 ft-lb)

INSTALLATION

Install the parts in the numerical order shown in the figure.

Fig. 9-54

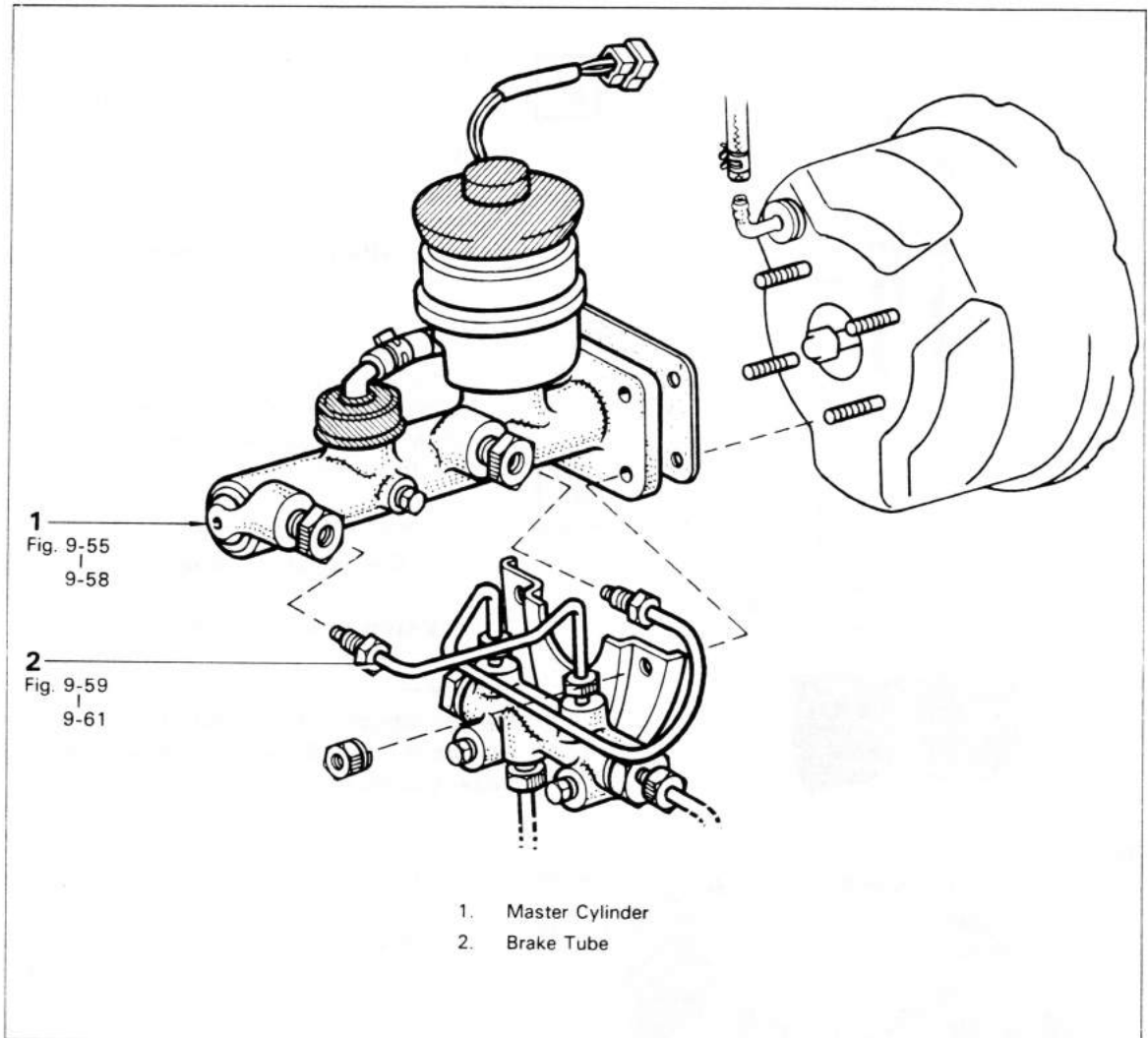
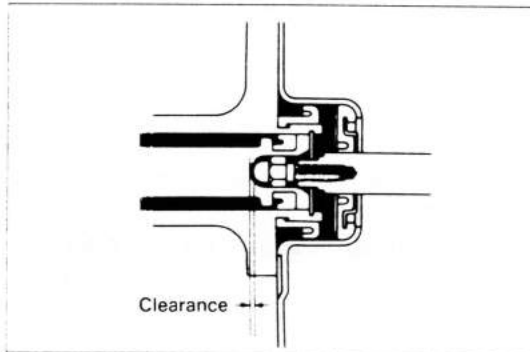

Fig. 9-55

**Adjust The Booster Push Rod Length**

The length of booster push rod is adjusted to provide the specified clearance between the push rod end and the master cylinder piston.

Clearance:

STD at Idling vacuum

0.1 - 0.5 mm

(0.004 - 0.020 in.)

Fig. 9-56

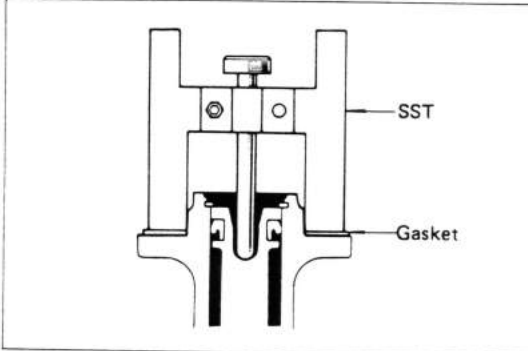

1. With the SST set as shown in the figure, push the pin until it contacts the piston rod.
SST [09737-00010]

— Note —

Measure with the gasket installed.

2. The internal booster should be at atmospheric pressure.
3. Then, with the SST placed upside down as shown in the figure, adjust the push rod length so that SST stands as high as the push rod.

SST [09737-00010]

**Clearance: 0 mm
(0 in.)**

Between SST and push rod

— Note —

By the above adjustment, the clearance will be 0.1 – 0.5 mm (0.004 – 0.020 in.) under the idling vacuum.

Fig. 9-57

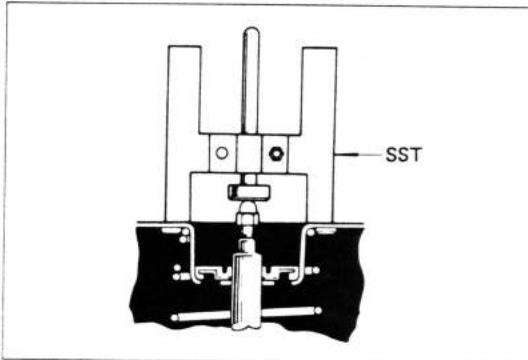

Fig. 9-58



4. Tighten the master cylinder mounting nuts.

**Tightening torque: 1.0 – 1.6 kg-m
(8 – 11 ft-lb)**

Fig. 9-59

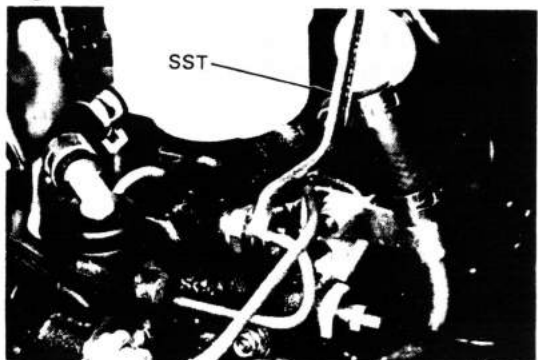

Connect the brake tube with SST.
SST [09751-36011]

**Tightening torque: 1.3 – 1.8 kg-m
(10 – 13 ft-lb)**

Fig. 9-60

**SEE
BRAKE PEDAL
ADJUSTMENT
SECTION
Fig. 9-5**

Adjust the pedal height and play.

Fig. 9-61

**SEE
AIR BLEEDING
SECTION
Fig. 9-11 to 9-14**

Bleed the air from the system.

BRAKE BOOSTER

REMOVAL

Remove the parts in the numerical order shown in the figure.

Fig. 9-62

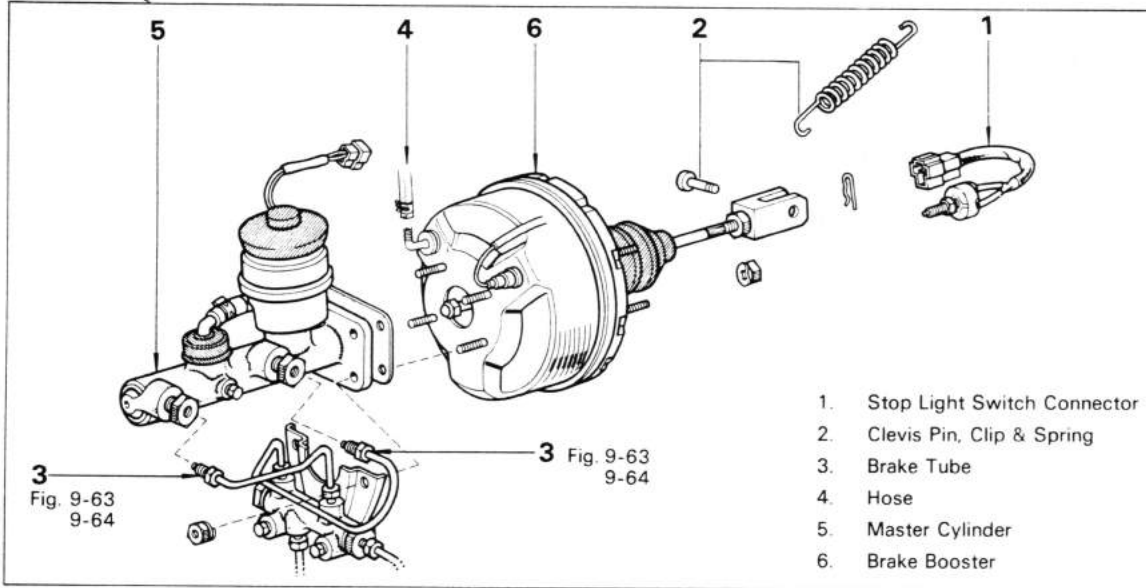
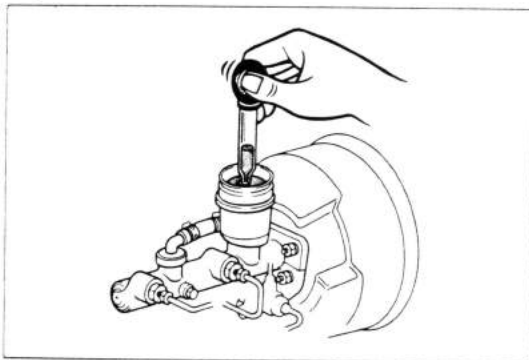
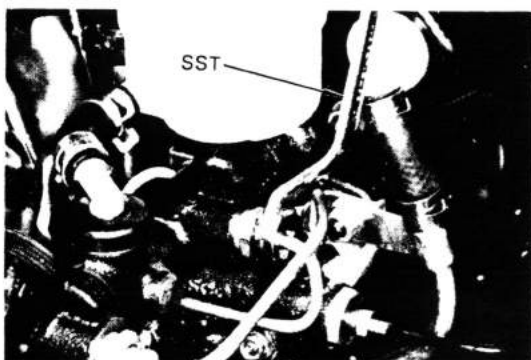

Fig. 9-63



Take out the fluid with a syringe or such.

Fig. 9-64



Disconnect the brake tube with SST.
 SST [09751-36011]

— Note —

Do not allow any brake fluid to get on painted surfaces.

DISASSEMBLY
(7.5 in. SINGLE TYPE: AISIN)

Disassemble the parts in the numerical order shown in the figure.

Fig. 9-65

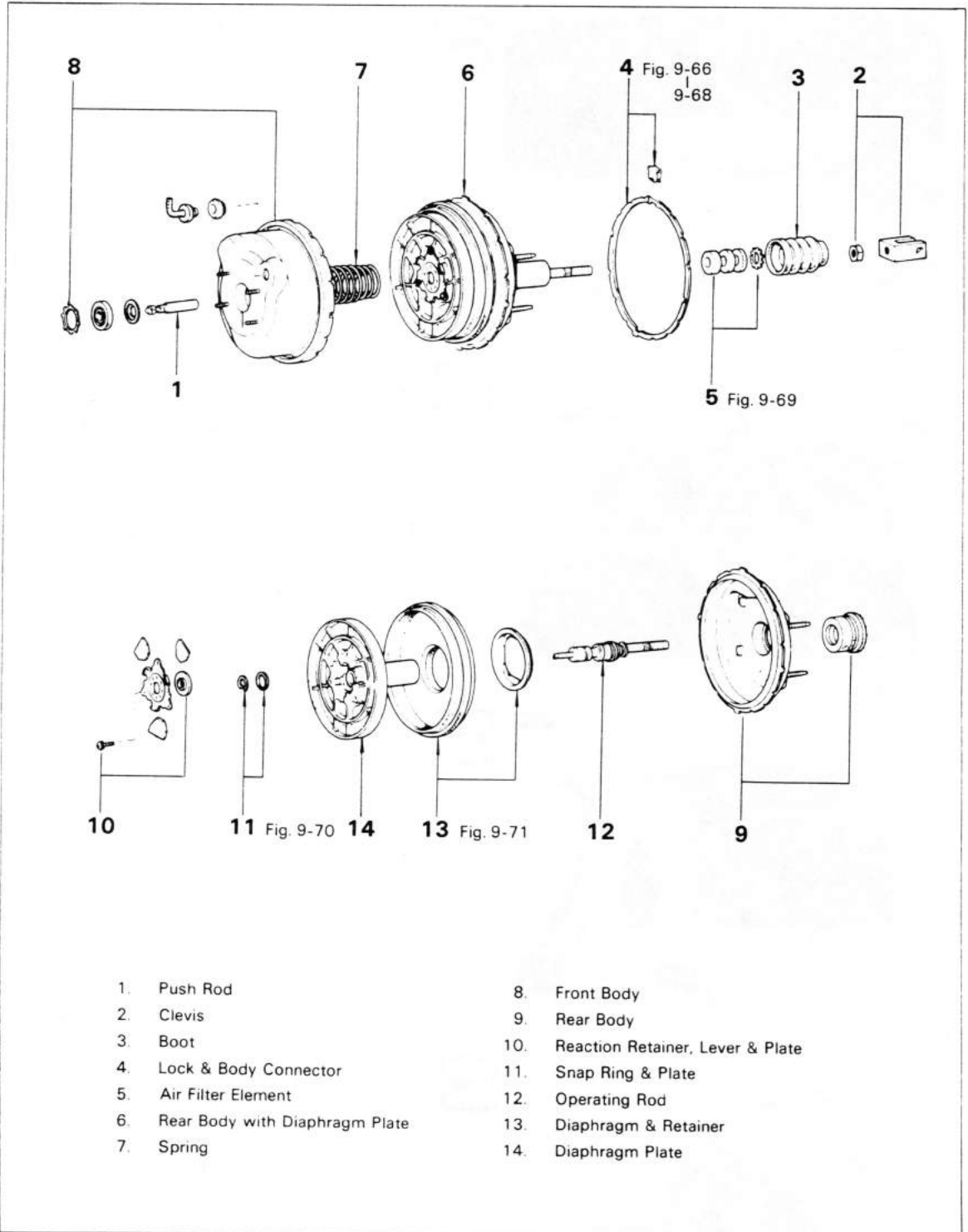

- | | |
|-----------------------------------|--------------------------------------|
| 1. Push Rod | 8. Front Body |
| 2. Clevis | 9. Rear Body |
| 3. Boot | 10. Reaction Retainer, Lever & Plate |
| 4. Lock & Body Connector | 11. Snap Ring & Plate |
| 5. Air Filter Element | 12. Operating Rod |
| 6. Rear Body with Diaphragm Plate | 13. Diaphragm & Retainer |
| 7. Spring | 14. Diaphragm Plate |

Fig. 9-66

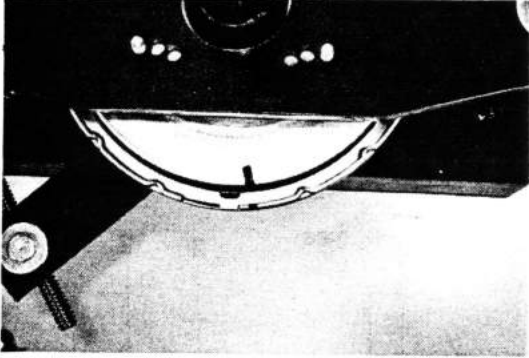

1. Place matchmarks on the front body and rear body.
2. Pry out the lock with a screwdriver.

Fig. 9-67

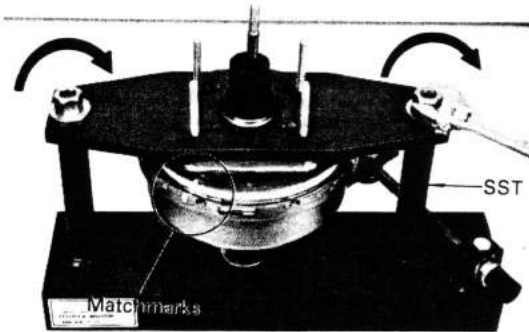

Set the booster to the SST.
SST (09753-00010) of set [09738-00020]

**Tightening torque: 1.1 – 1.3 kg-m
(8 – 9 ft-lb)**

– Note –

Tighten the left and right nuts uniformly.

Fig. 9-68

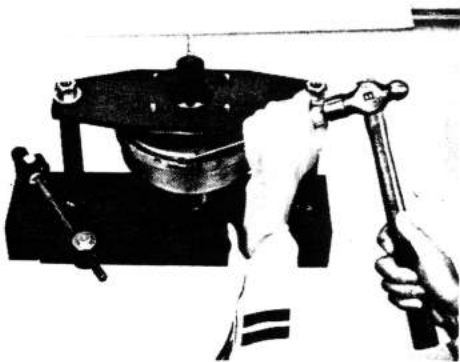

- Remove the body connector by turning it counterclockwise with a screwdriver.

Fig. 9-69

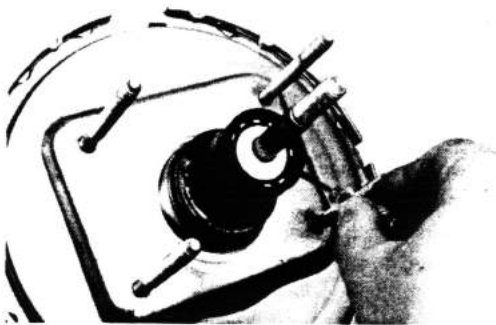

- Remove the snap ring and plate with snap ring pliers.

Fig. 9-70

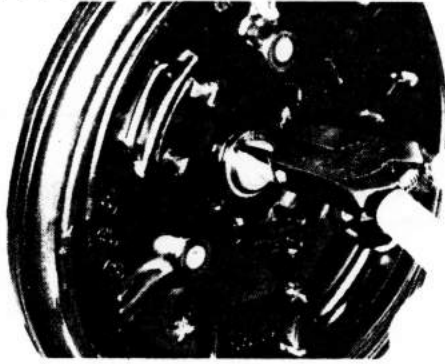

Pry out the circular ring with a screw driver and pull out the air valve together with the air filter elements.

Fig. 9-71

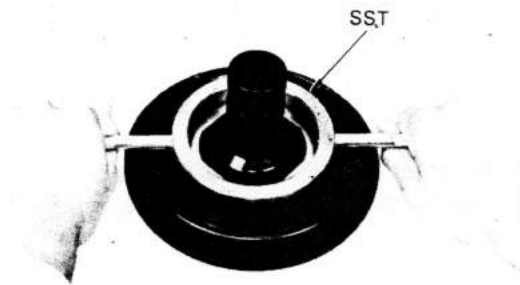

Remove the diaphragm retainer with SST. SST [09736-30020]

Fig. 9-72

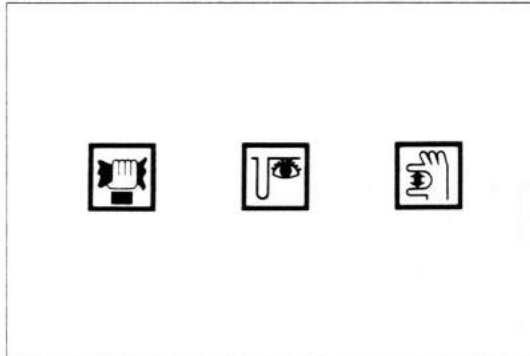

INSPECTION & REPAIR

Inspect the disassembled parts on the following points and repair or replace if necessary.

Fig. 9-73

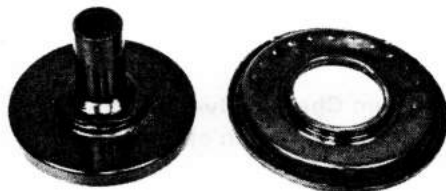

Diaphragm & Booster Piston

Inspect the diaphragm and booster piston for wear, damage or cracks.

Fig. 9-74

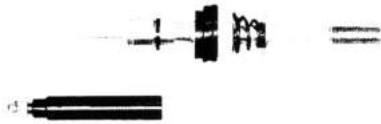

Booster Air Valve & Piston Rod

Inspect for wear, damage or bending.

Fig. 9-75

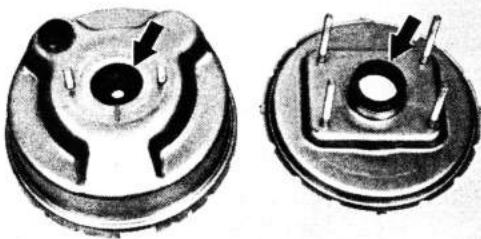

Booster Body, Seal & Bearing

Inspect the booster bodies, seal and bearing for wear or damage.

Fig. 9-76

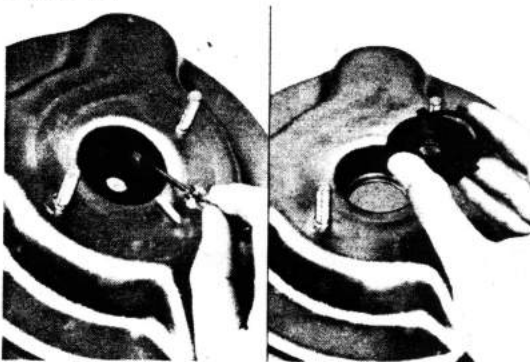

Replace The Seal

1. Remove the seal from the shell by prying.
2. Install a new seal.



Fig. 9-77

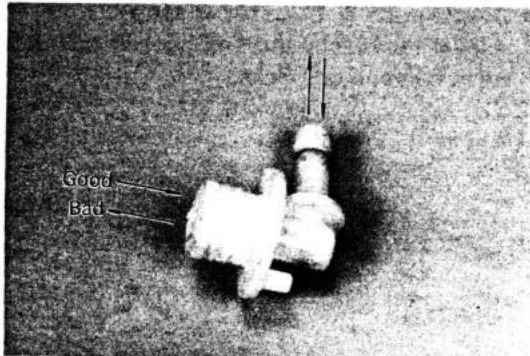

Vacuum Check Valve

Check the operation of the valve.

ASSEMBLY

Assemble the parts in the numerical order shown in the figure.

Fig. 9-78

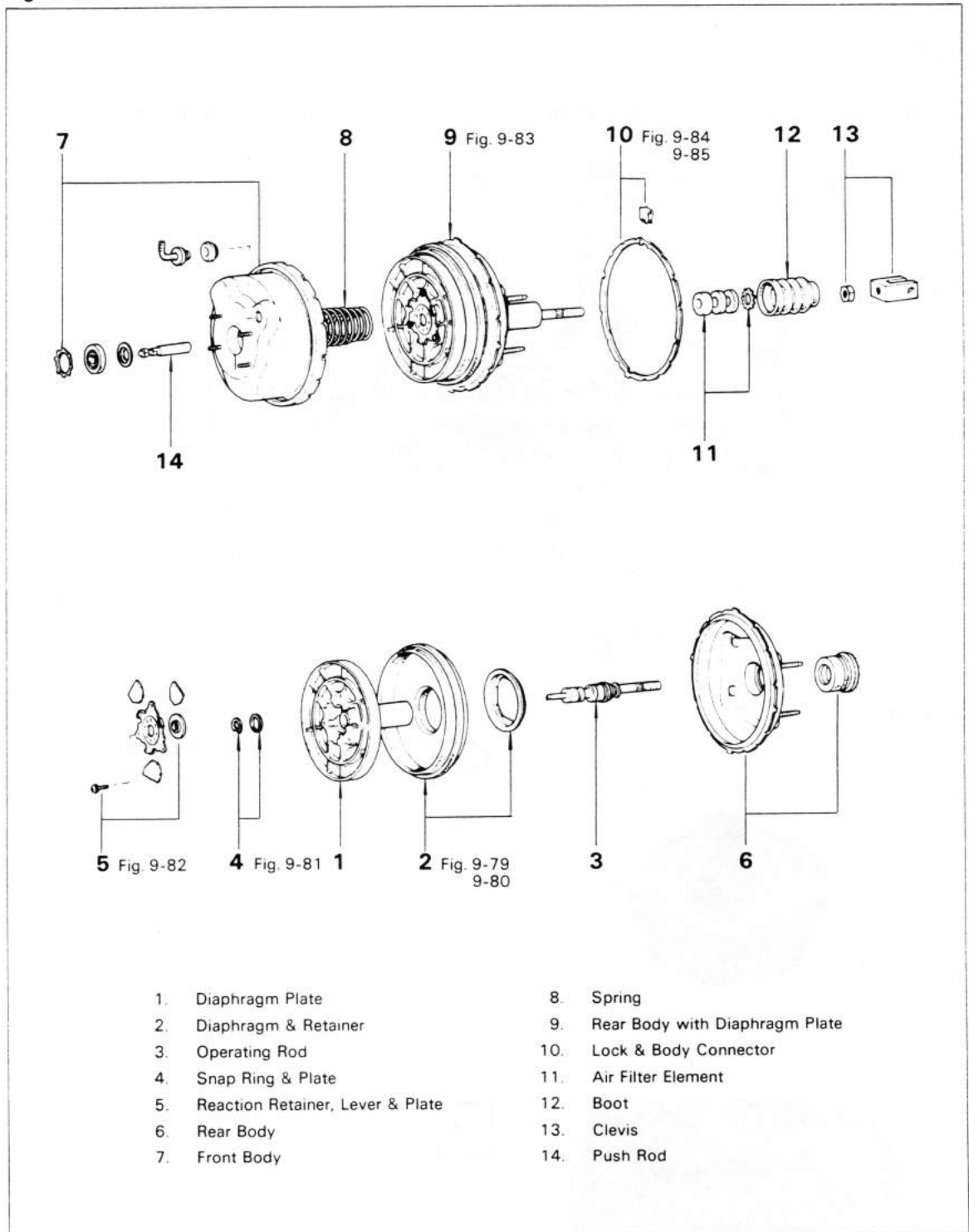

Fig. 9-79

— Note —

Before assembly, coat the parts shown below with silicon grease (furnished in repair kit).

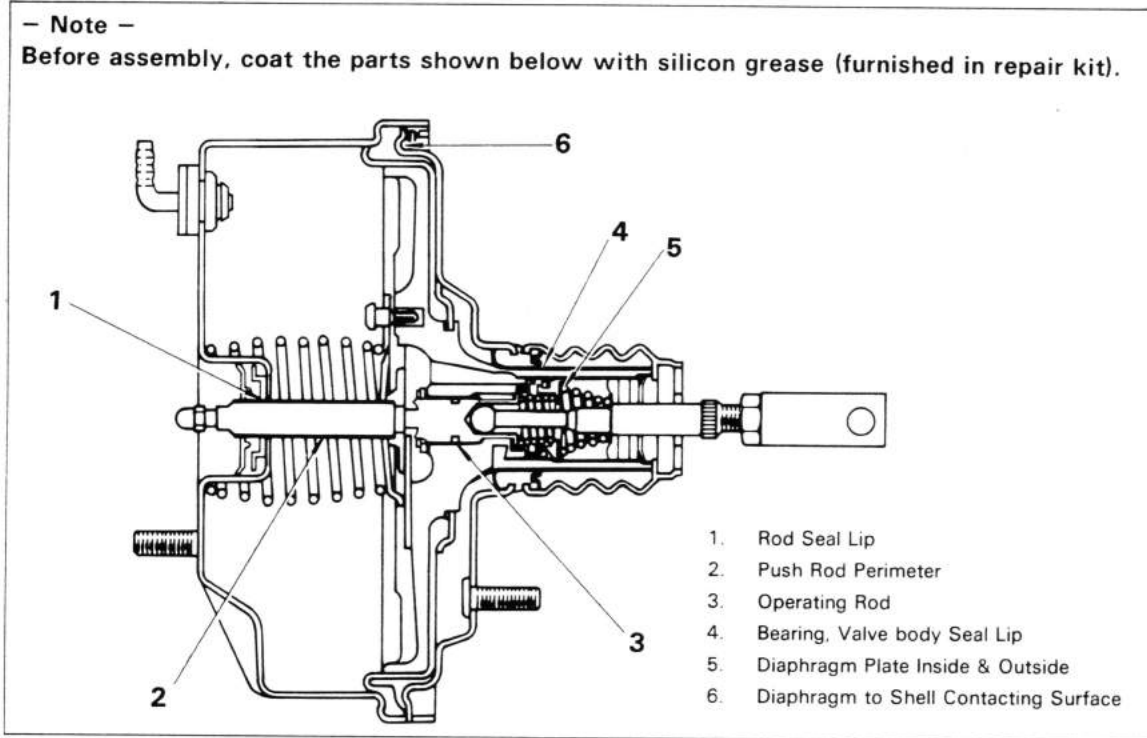
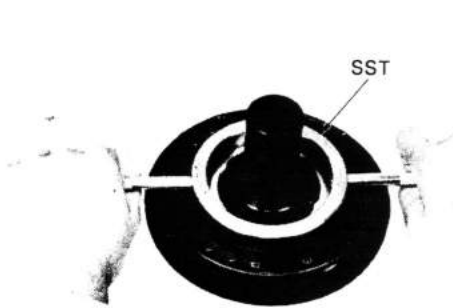

Fig. 9-80



Install the retainer by turning the SST about 45°.
 SST [09736-30020]

Fig. 9-81



Install the snap ring onto the air valve.

Fig. 9-82



Install the reaction levers and plate with its protrusion directed upward.

Fig. 9-83

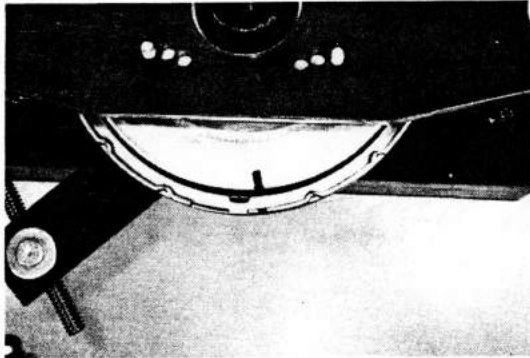

Face the body connector in the direction shown in the figure.

Fig. 9-84

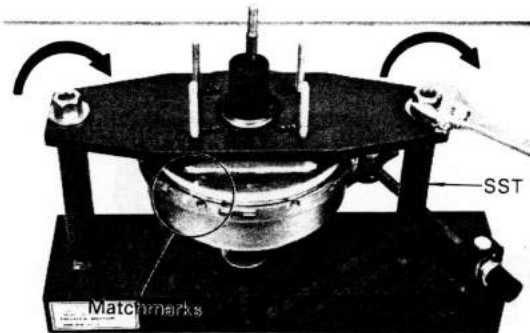

Set the booster to SST.
SST (09753-00010) of set [09738-00020]
Tightening torque: 1.1 – 1.3 kg-m
(8 – 9 ft-lb)

– Note –

1. Align the matchmarks on the body.
2. Tighten the left and right nuts evenly.

Fig. 9-85

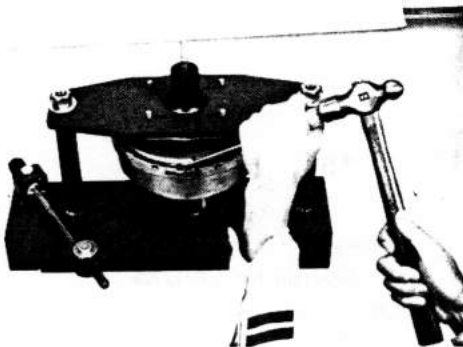

Turn the body connector clockwise with a screwdriver.

DISASSEMBLY

(9.0 in. SINGLE TYPE : AISIN)

Disassemble the parts in the numerical order shown in the figure.

Fig. 9-86

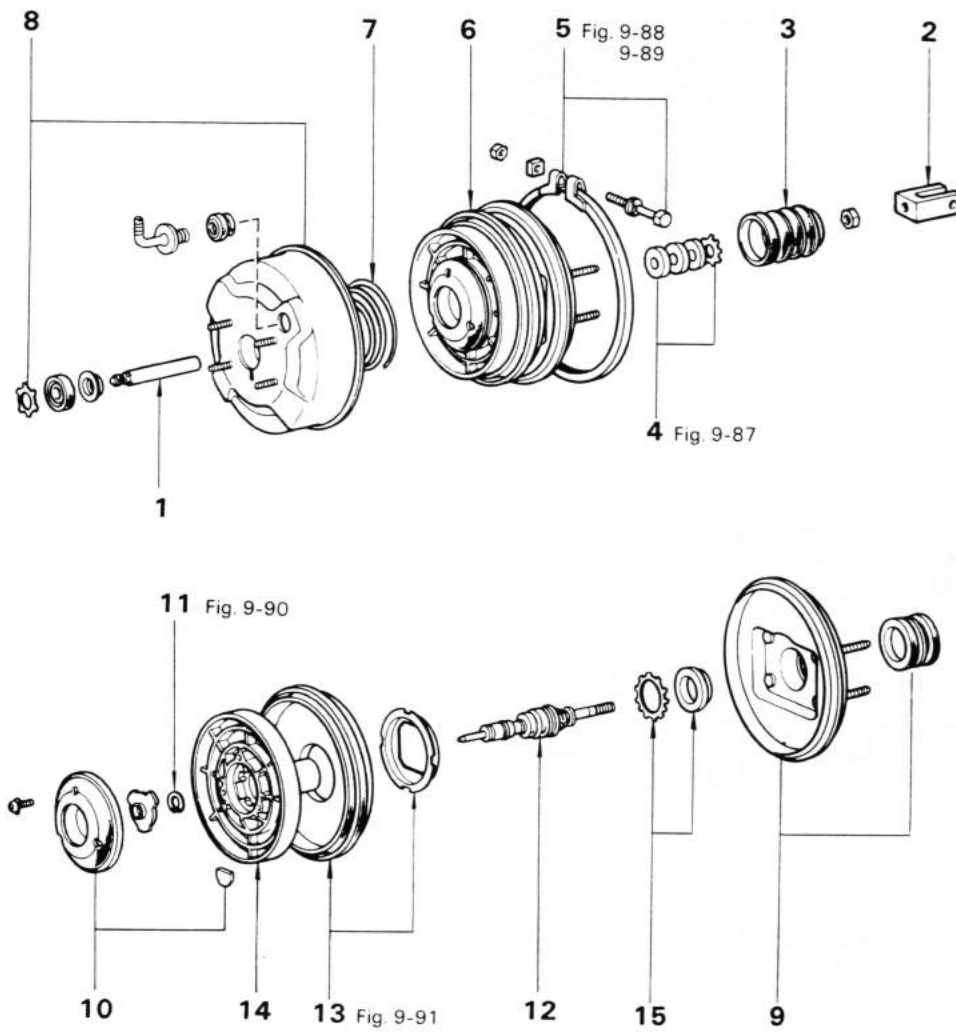

- | | |
|-----------------------------------|---|
| 1. Push Rod | 9. Rear Body |
| 2. Clevis | 10. No.2 Reaction, No. 1 Retainer,
Plate & Lever |
| 3. Boot | 11. Snap Ring |
| 4. Air Filter Element | 12. Operating Rod |
| 5. Booster Band | 13. Diaphragm & Retainer |
| 6. Rear Body with Diaphragm Plate | 14. Diaphragm Plate |
| 7. Spring | 15. Piston Bearing & Circular Internal Ring |
| 8. Front Body | |

Fig. 9-87

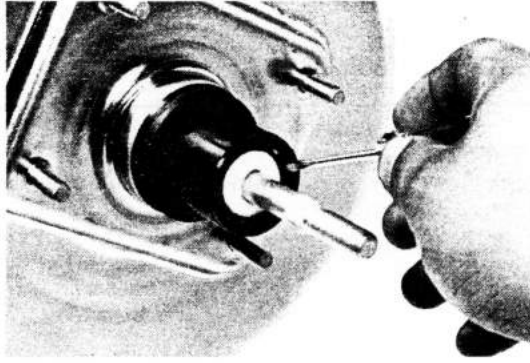

Remove the retainer and filter elements with a screwdriver.

Fig. 9-88

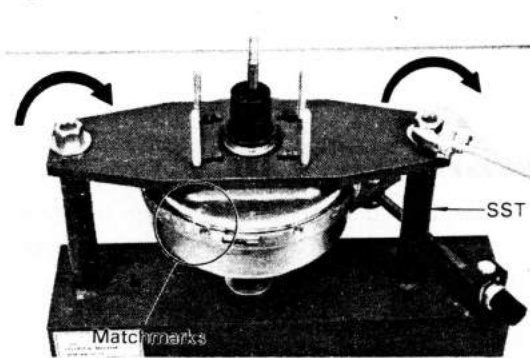

Place matchmarks on the front and rear body, and fix to the SST.
SST (09753-00010) of set [09738-00020]

Fig. 9-89

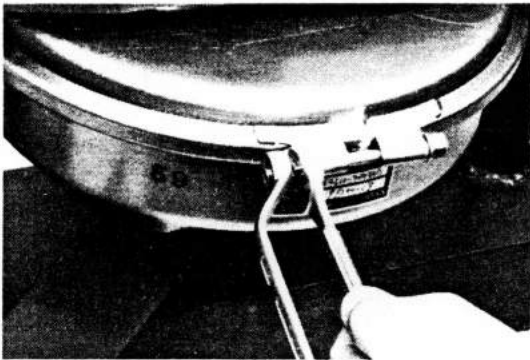

1. Remove the booster band lock nut.
2. Remove the booster band.

Fig. 9-90

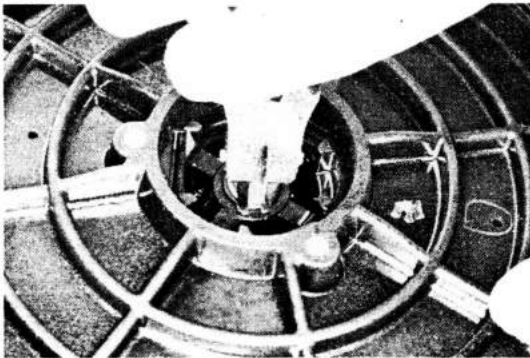

Remove the snap ring

Fig. 9-91



Remove the diaphragm and the diaphragm plate with SST.
SST [09736-30020]

Fig. 9-92

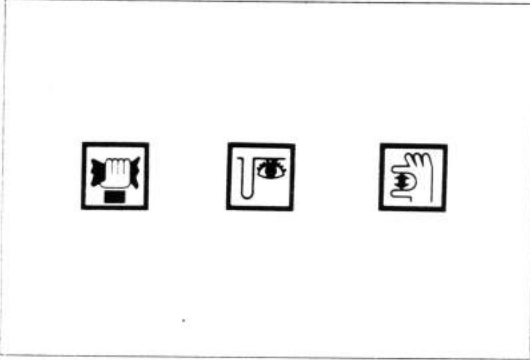

INSPECTION & REPAIR

Inspect the disassembled parts on the following points, and repair or replace parts if necessary.

Fig. 9-93

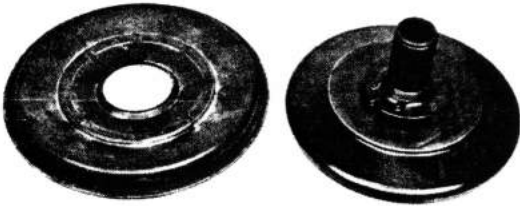

Diaphragm & Diaphragm Plate

Inspect the diaphragm and diaphragm plate for wear, damage or cracks.

Fig. 9-94

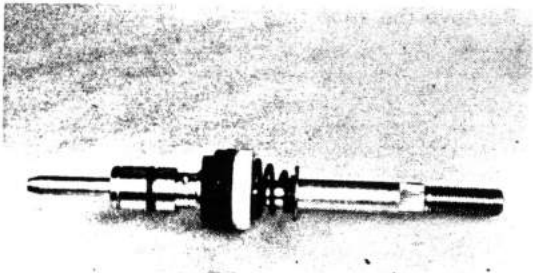

Valve Operating Rod

Inspect the valve operating rod for wear or damage.

Fig. 9-95

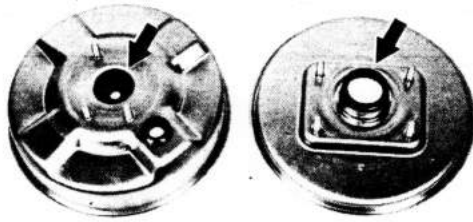
**Body & Body Seal**

Inspect the seals for wear or damage.

Fig. 9-96

**Replace The Seal**Remove the seal from the shell.
Install the new seal.

Fig. 9-97

**Replace The Bearing**Remove the bearing from the shell and install
a new bearing.

Fig. 9-98

**Vacuum Check Valve**

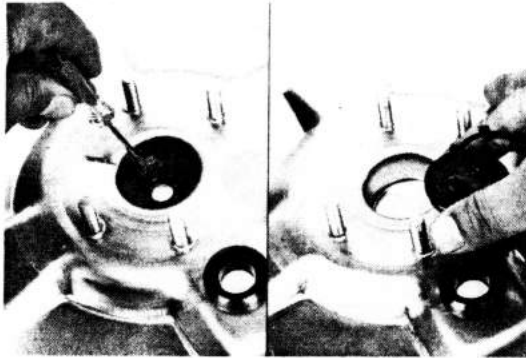
Check the operation of the valve.

ASSEMBLY

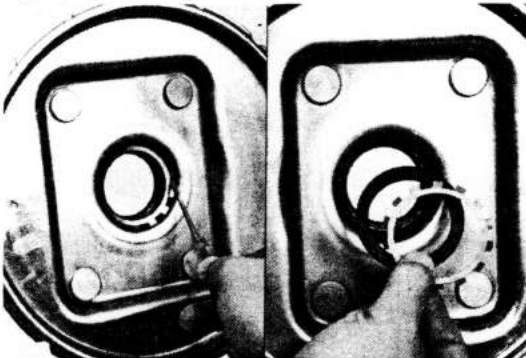
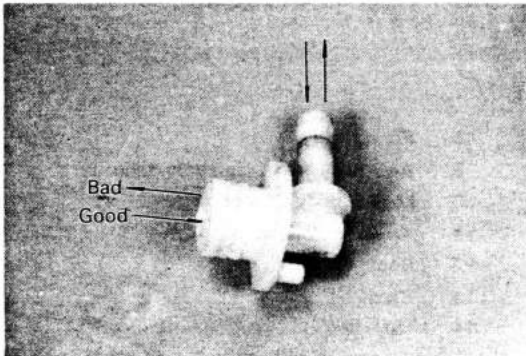
Assemble the parts in numerical order shown in the figure.

Fig. 9-99

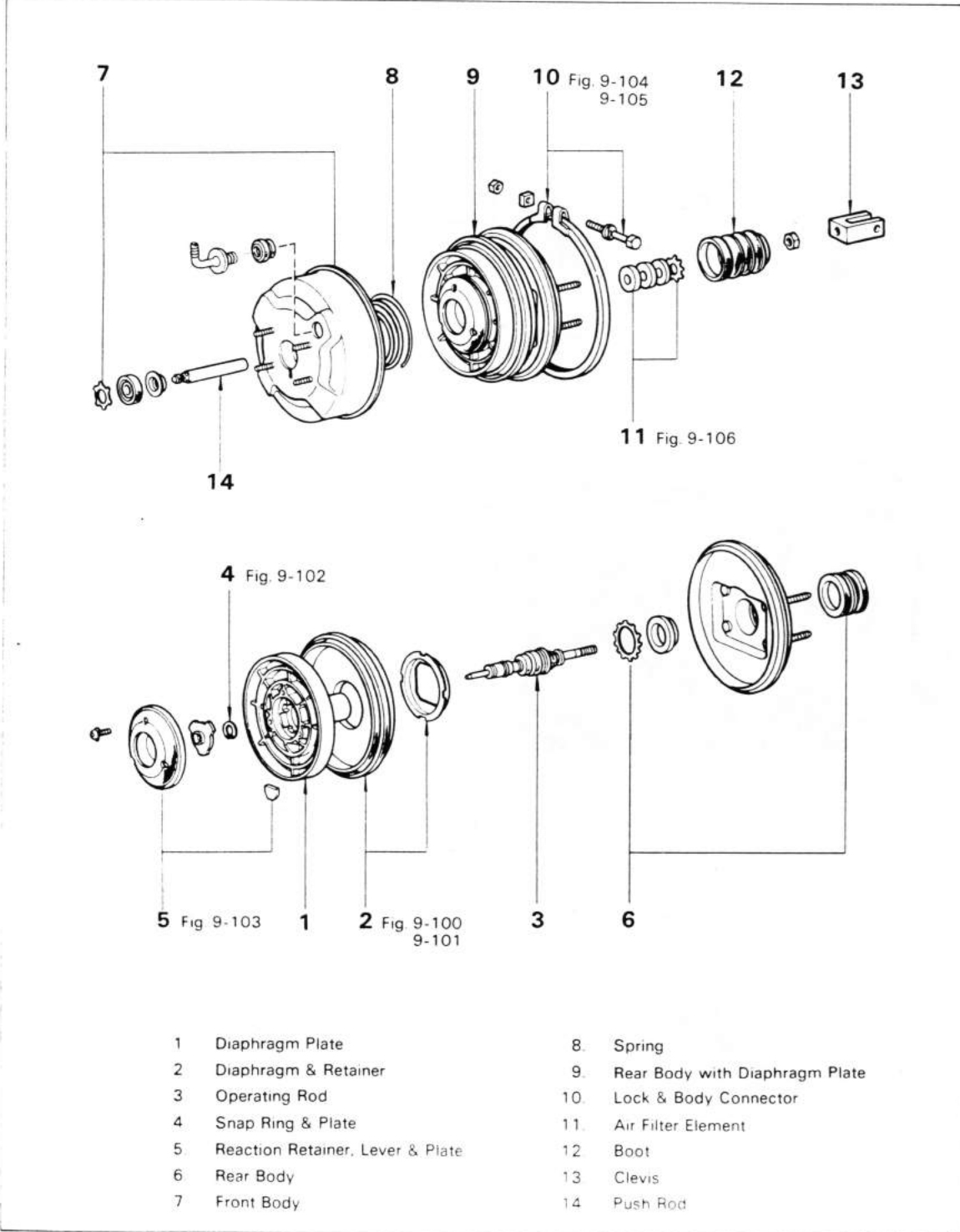

- | | | | |
|---|----------------------------------|-----|--------------------------------|
| 1 | Diaphragm Plate | 8. | Spring |
| 2 | Diaphragm & Retainer | 9. | Rear Body with Diaphragm Plate |
| 3 | Operating Rod | 10. | Lock & Body Connector |
| 4 | Snap Ring & Plate | 11. | Air Filter Element |
| 5 | Reaction Retainer, Lever & Plate | 12. | Boot |
| 6 | Rear Body | 13. | Clevis |
| 7 | Front Body | 14. | Push Rod |

Fig. 9-100

— Note —

Before assembly, coat the parts shown below with silicon grease (furnished in repair kit).

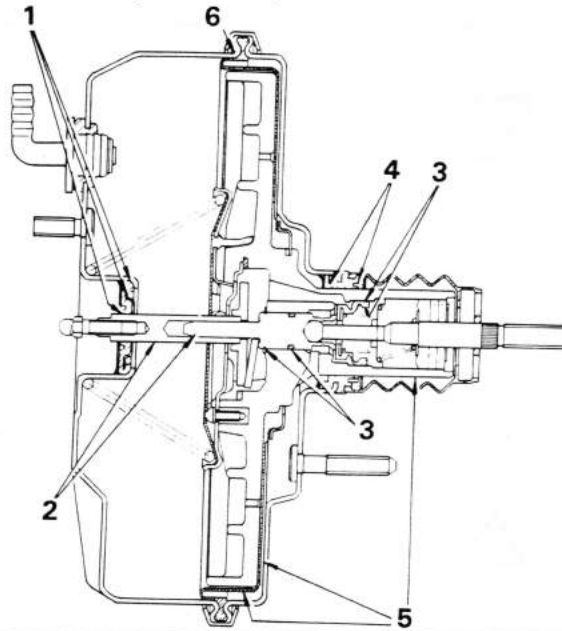

1. Rod Seal Lip & Perimeter
2. Push Rod
3. Operating Rod & Seal
4. Bearing, Valve Body Seal Lip
5. Diaphragm Plate Inside & Outside
6. Diaphragm to Shell Contacting Surface
& to Retainer Contacting Surface

Fig. 9-101



Install the retainer by turning about 45° with SST.
SST [09736-30020]

Fig. 9-102

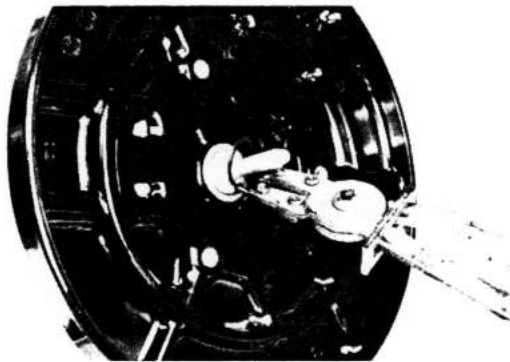

Install the plate and snap ring onto the valve operating rod.

Fig. 9-103

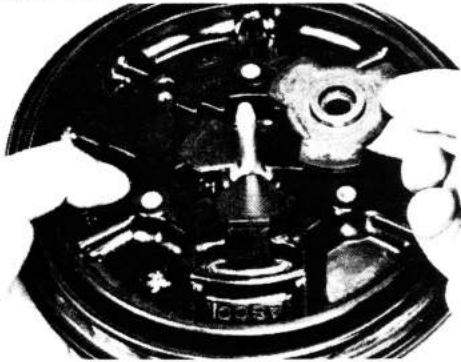

Install the reaction levers and plate with its protrusion directed upward.

Fig. 9-104

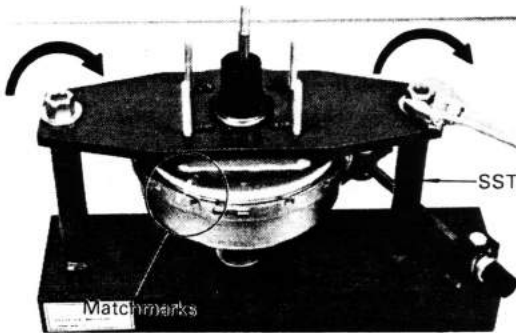

Align the matchmarks and fix to the SST. SST (09753-00010) of set [09738-00020]

Fig. 9-105

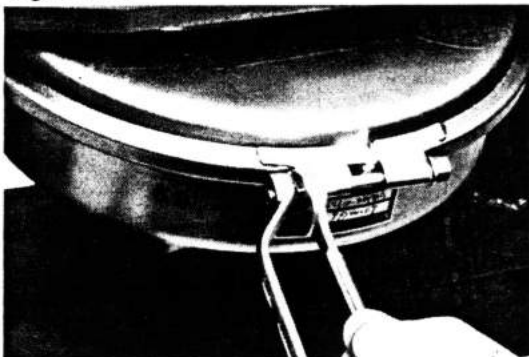

Install the booster band with SST. SST (09753-00010) of set [09738-00020]

Fig. 9-106

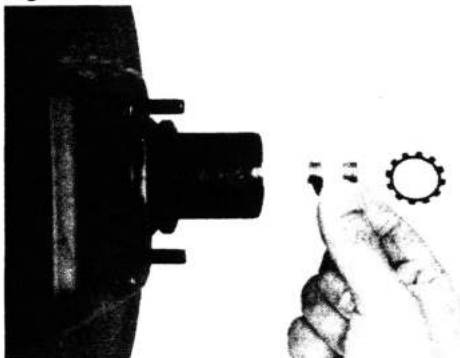

Install the air filter elements and retainer.

DISASSEMBLY

(7.5 in. TANDEM TYPE : AISIN)

Disassemble the parts in the numerical order shown in the figure.

Fig. 9-107

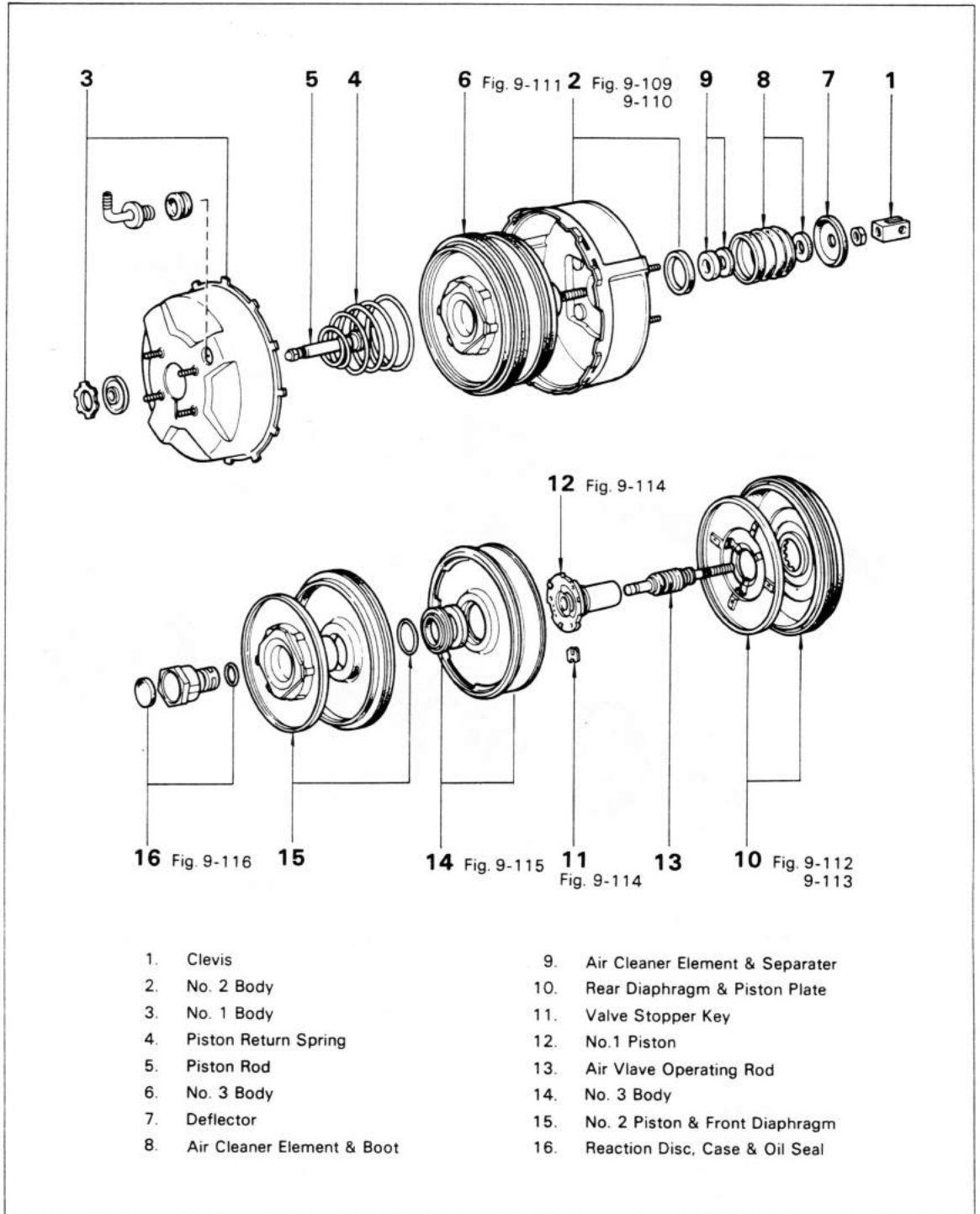

- | | |
|-------------------------------|------------------------------------|
| 1. Clevis | 9. Air Cleaner Element & Separator |
| 2. No. 2 Body | 10. Rear Diaphragm & Piston Plate |
| 3. No. 1 Body | 11. Valve Stopper Key |
| 4. Piston Return Spring | 12. No.1 Piston |
| 5. Piston Rod | 13. Air Valve Operating Rod |
| 6. No. 3 Body | 14. No. 3 Body |
| 7. Deflector | 15. No. 2 Piston & Front Diaphragm |
| 8. Air Cleaner Element & Boot | 16. Reaction Disc, Case & Oil Seal |

cardiagn.com

(7.5 in. TANDEM TYPE : JKC)

Disassemble the parts in the numerical order shown in the figure.

Fig. 9-108

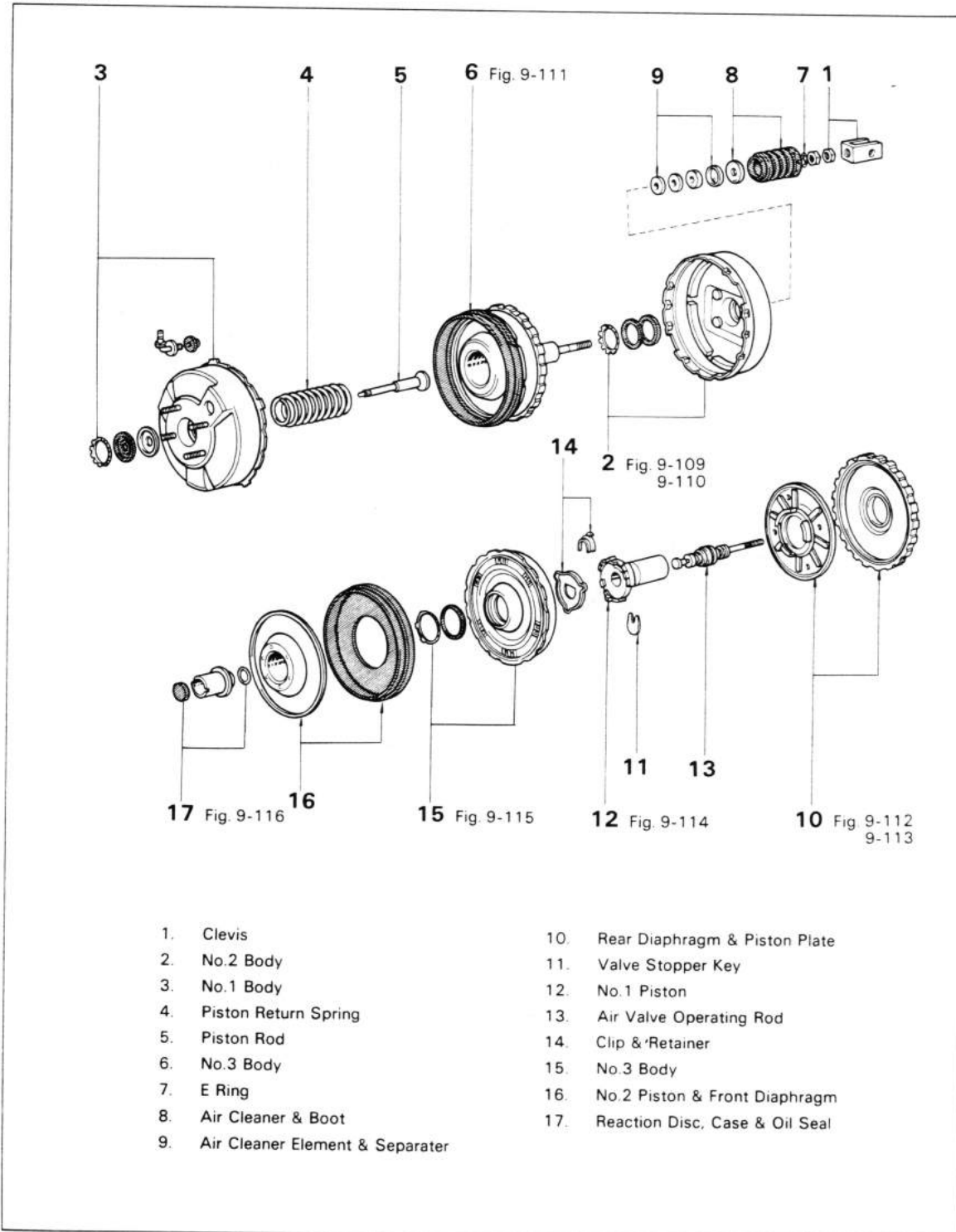

- | | |
|------------------------------------|------------------------------------|
| 1. Clevis | 10. Rear Diaphragm & Piston Plate |
| 2. No.2 Body | 11. Valve Stopper Key |
| 3. No.1 Body | 12. No.1 Piston |
| 4. Piston Return Spring | 13. Air Valve Operating Rod |
| 5. Piston Rod | 14. Clip & Retainer |
| 6. No.3 Body | 15. No.3 Body |
| 7. E Ring | 16. No.2 Piston & Front Diaphragm |
| 8. Air Cleaner & Boot | 17. Reaction Disc, Case & Oil Seal |
| 9. Air Cleaner Element & Separator | |

Fig. 9-109

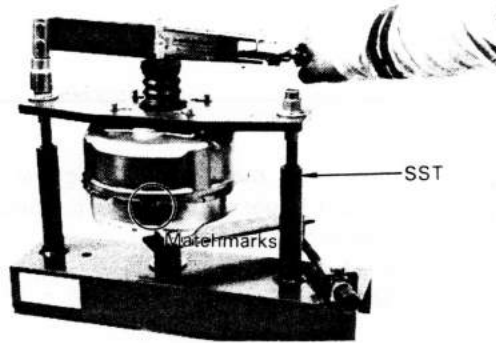

Disconnect the body.

1. Place matchmarks on the No.1 and No.2 body.
2. Install the booster to the SST and tighten the nut.

SST [09738-00020]

Tightening torque:

1.3 – 1.8 kg-m

(10 – 13 ft-lb)

– Note –

Tighten the right and left nuts evenly.

Fig. 9-110

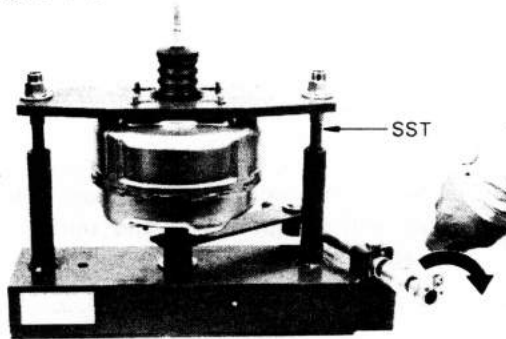

3. Turn the joint handle of the SST to separate No.1 body and No.2 body.

SST [09738-00020]

Fig. 9-111

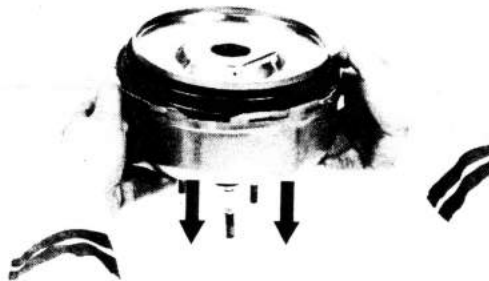

With the valve operating rod facing downward, No.2 body and remove the No.3 body.

Fig. 9-112

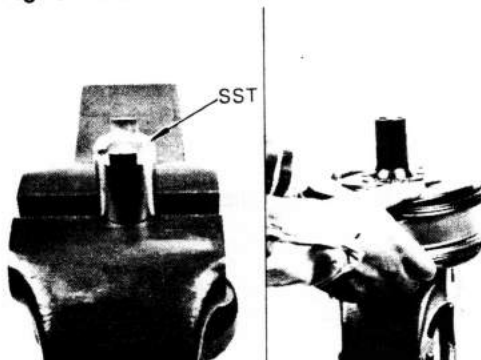

Disassemble the No.3 body.

1. Clamp SST in a vise and insert the No.3 body into it.

SST [09738-00020]

Fig. 9-113



2. Of the 4 ribs, push in two diagonal ones with your finger and turn the piston plate counterclockwise. Then remove the diaphragm and piston plate.

Fig. 9-114

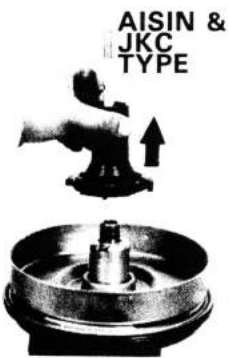

3. Push in the valve operating rod, pull out the valve stopper key and remove the piston No.1.

Fig. 9-115



4. Remove the No.3 body.

Fig. 9-116

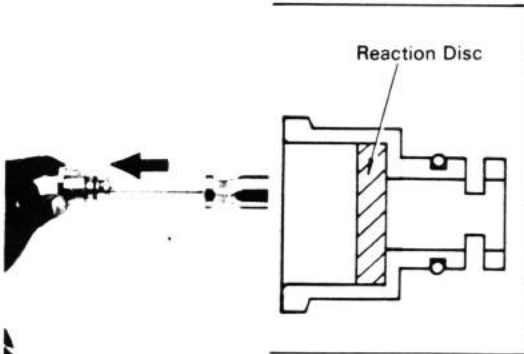

- Remove the reaction disc from the case.

Fig. 9-117
AISIN TYPE



INSPECTION & REPAIR

Rear Diaphragm & Plate

Inspect for wear, damage or cracks.

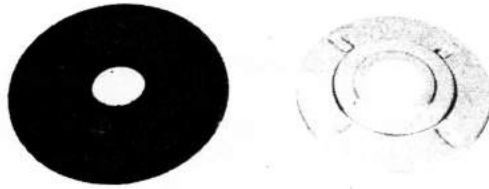

JKC TYPE

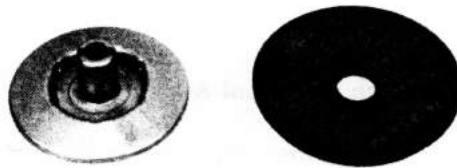

Fig. 9-118
AISIN TYPE



Front Diaphragm & No.2 Piston

Inspect the diaphragm No.2 piston and oil seal for wear, damage or cracks.



JKC TYPE

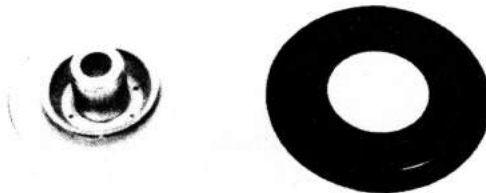

Fig. 9-119

**Replace The Seal & Bearing**

AISIN TYPE

1. Remove the seal and bearing from the No.3 body with SST.

SST [09726-35010] No.1

[09753-30020]

[09608-20011] No.2

Fig. 9-120

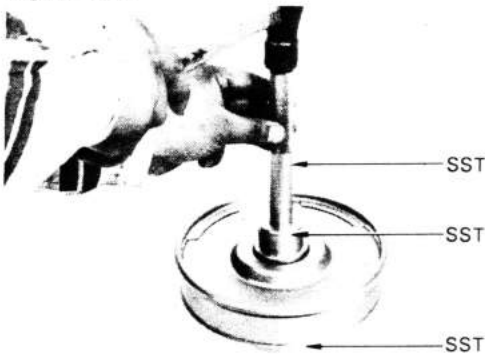

2. Install the seal and bearing to the No.3 body with SST.

SST [09726-35010] No.1

[09753-30020]

- Note -

1. Coat the outside of the oil seal with silicon grease.
2. Be careful not to crack the bearing during assembly.

Fig. 9-121

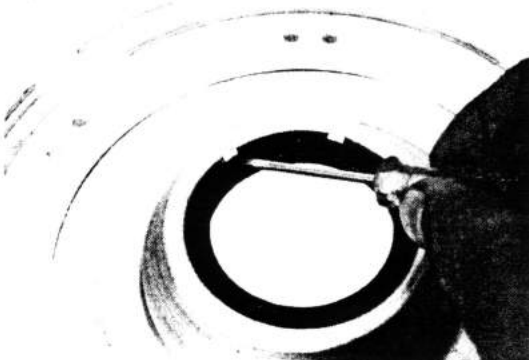
**Replace The Seal & Bearing**

JKC TYPE

1. Remove the circular ring and seal from the No.3 body.

Fig. 9-122

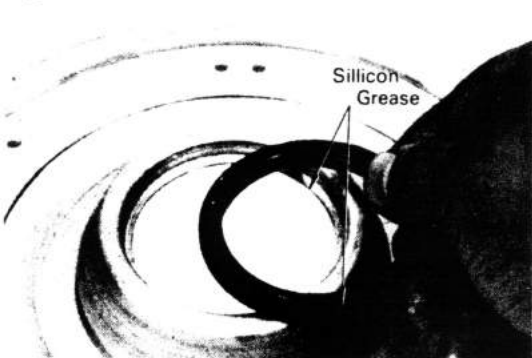

2. Apply silicon grease onto the seal and install them into the No.3 Body.

Fig. 9-123

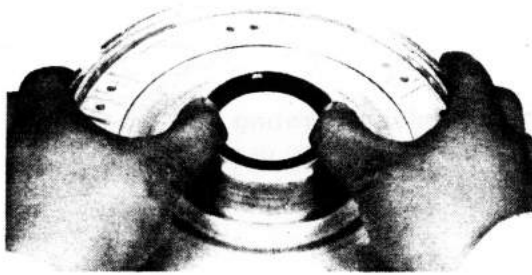

3. Install a circular ring into the No.2 piston.

Fig. 9-124

AISIN TYPE



Piston Rod

Inspect for wear, damage or bend.

JKC TYPE



Fig. 9-125

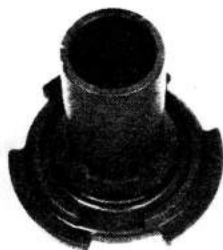

Booster Piston

Inspect for scratches, cracks or deformation.

Fig. 9-126
AISIN TYPE



Air Valve Operating Rod

Inspect for wear or damage.

JKC TYPE



Fig. 9-127

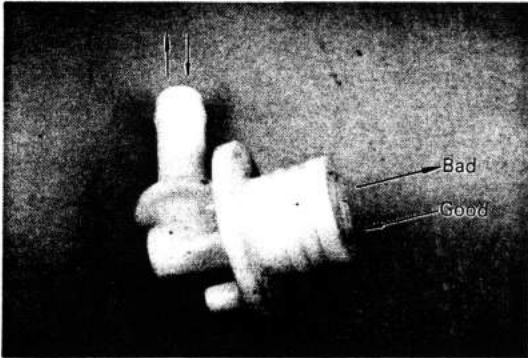

Vacuum Check Valve

Check the operation of the valve

Fig. 9-128

AISIN TYPE



Booster Body, Seal & Bearing

Inspect the booster bodies, seals and bearing for wear or damage.

Fig. 9-129
JKC TYPE

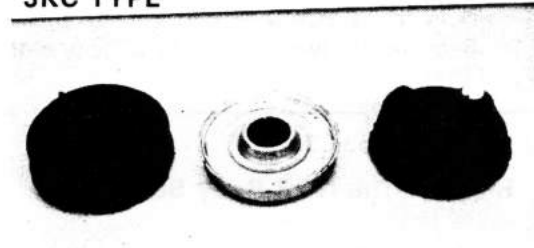

Booster Body, Seal & Bearing

Inspect the booster bodies, seals and bearing for wear or damper.

Fig. 9-130

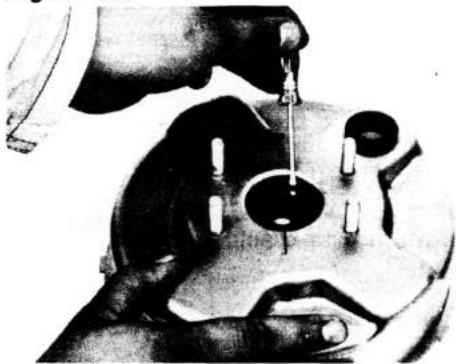

Replace The No.1 Body Seal

AISIN TYPE

1. Remove the circular ring and seal from the No.1 body seal.

Fig. 9-131

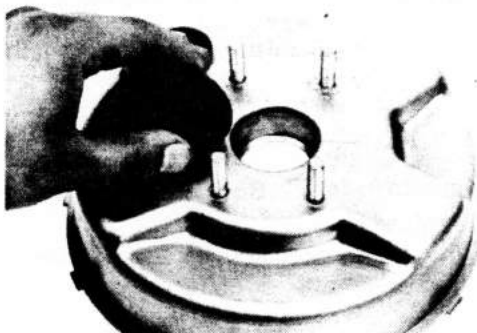

2. Apply silicon grease onto the seal and install them into the No.1 body.

Fig. 9-132

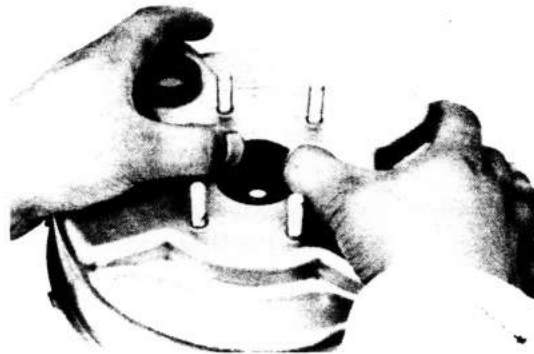

3. Install a circular ring into the No.1 body.

Fig. 9-133

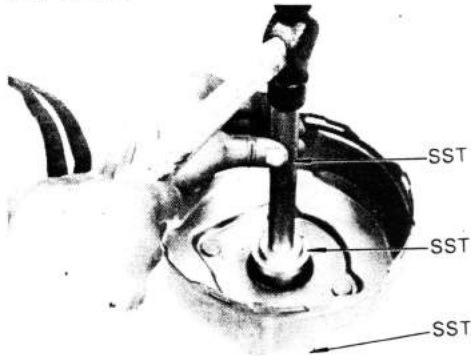
**Replace The No.2 Body Seal**

AISIN TYPE

1. Remove the seal from the No.2 body with SST.

SST [09726-35010] No.1
 [09753-30020]
 [09608-20011] No.2

Fig. 9-134

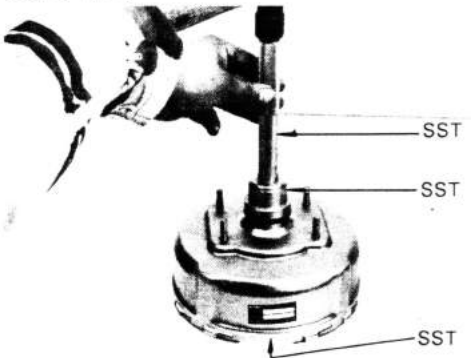

2. Install a new seal to the No.2 body seal with SST.

SST [09726-35010] No.1
 [09608-35010]
 [09753-30020]
 [09608-20011] No.2

- Note -

Be careful not to crack the bearing during assembly.

Fig. 9-135

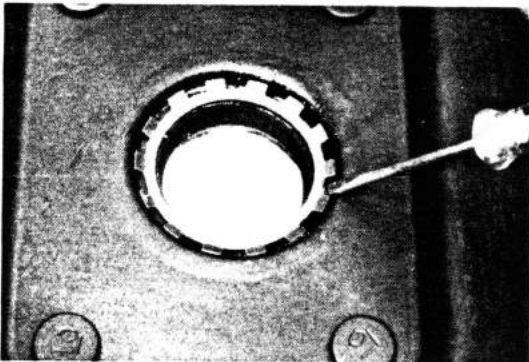
**Replace The No.2 Body Seal**

JKC TYPE

1. Remove the circular ring and seal from the No.2 body seal.

Fig. 9-136



2. Apply silicon grease onto the seal and install them into the No.2 body.

Fig. 9-137

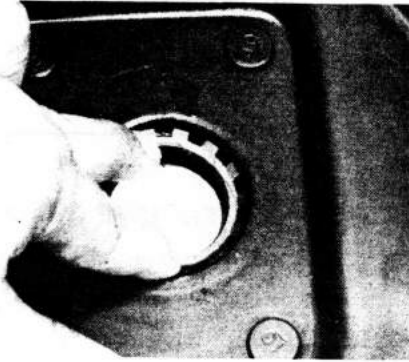

3. Install a circular ring into the No.2 body.

Fig. 9-138

AISIN TYPE



Reaction Disc & Case

Inspect for wear, damage, cracks or corrosion.

JKC TYPE

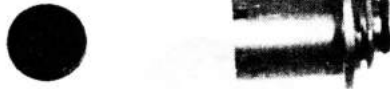

**ASSEMBLY
(7.5 in. TANDEM TYPE : AISIN)**

Assemble the parts in the numerical order shown in the figure.

Fig. 9-139

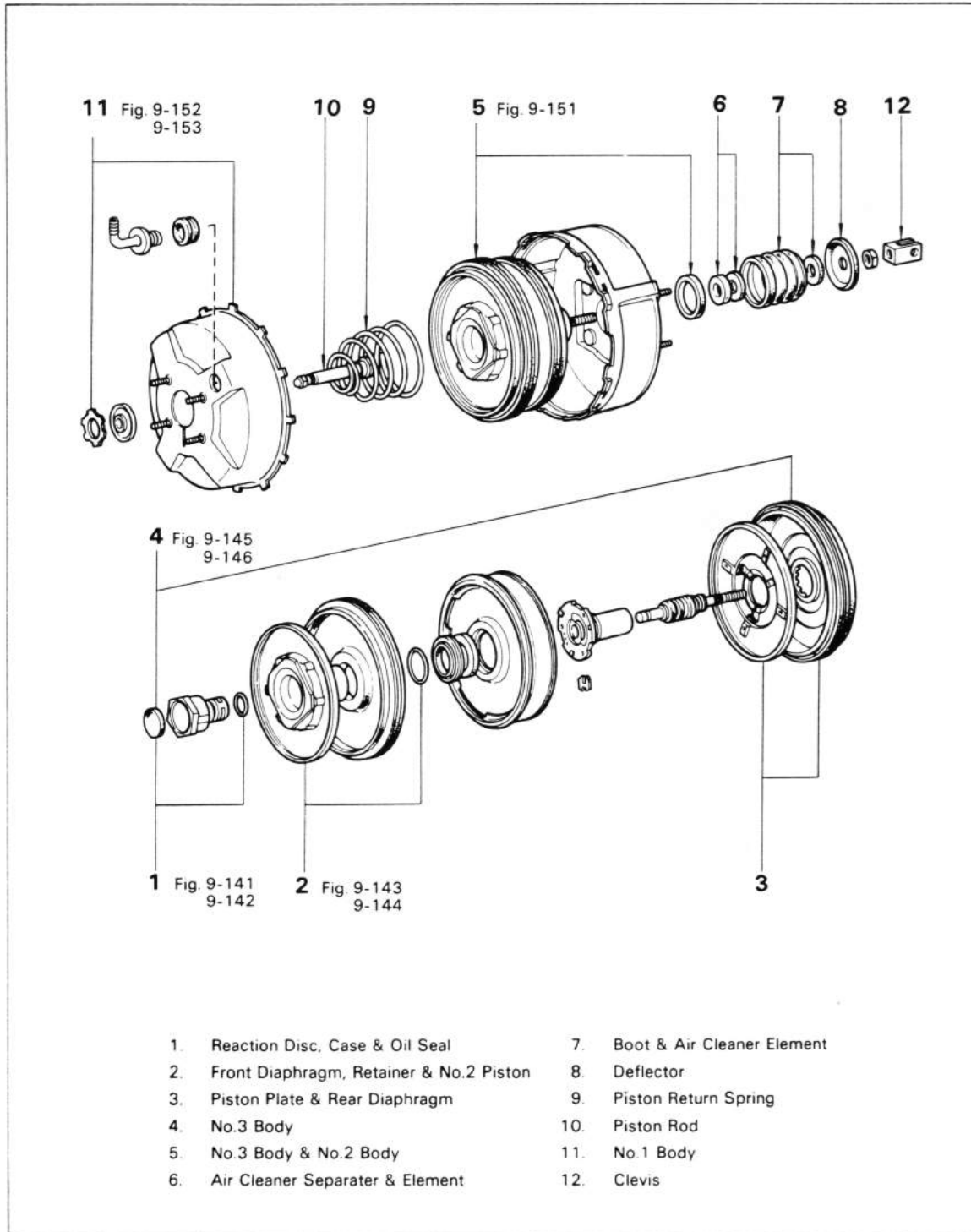

(7.5 in. TANDEM TYPE : JKC)

Assemble the parts in the numerical order shown in the figure.

Fig. 9-140

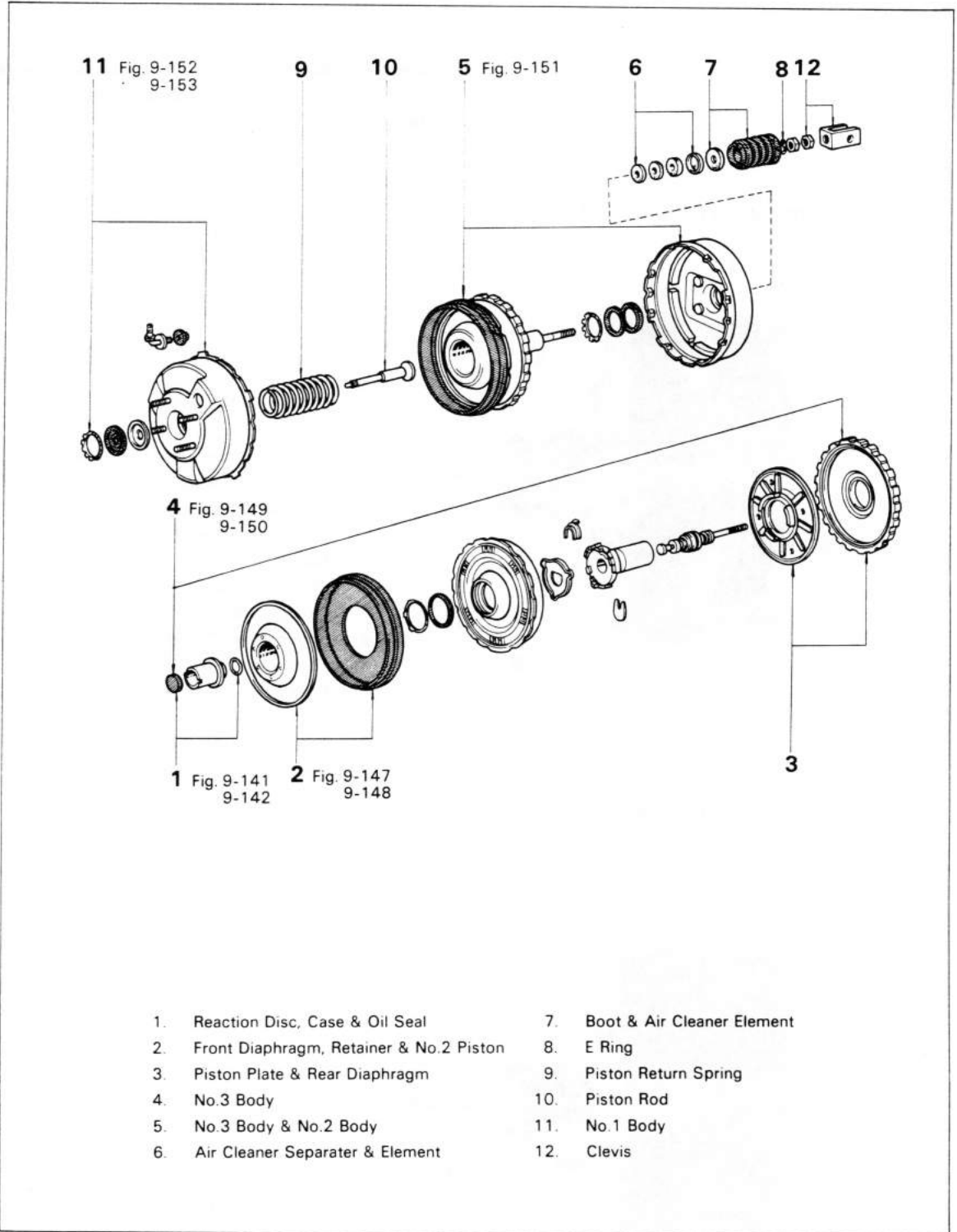

- | | |
|--|-------------------------------|
| 1. Reaction Disc, Case & Oil Seal | 7. Boot & Air Cleaner Element |
| 2. Front Diaphragm, Retainer & No.2 Piston | 8. E Ring |
| 3. Piston Plate & Rear Diaphragm | 9. Piston Return Spring |
| 4. No.3 Body | 10. Piston Rod |
| 5. No.3 Body & No.2 Body | 11. No.1 Body |
| 6. Air Cleaner Separator & Element | 12. Clevis |

— Note —

Before assembly, coat the parts shown below with silicon grease (furnished in repair kit).

Fig. 9-141

(7.5 in. TANDEM TYPE : AISIN)

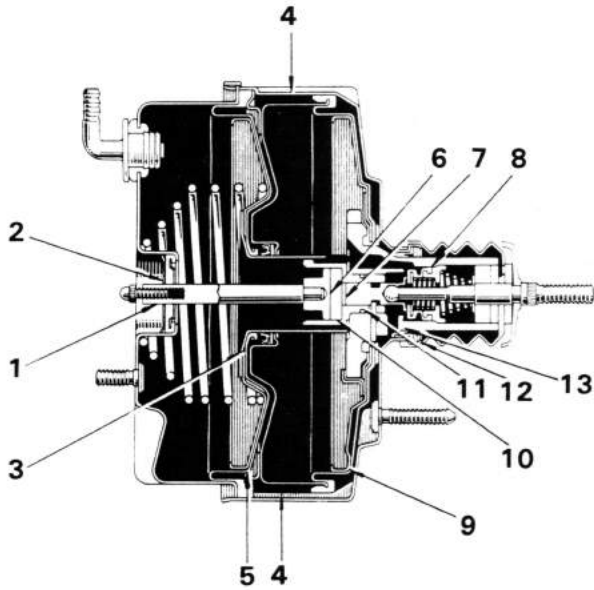

1. Piston Rod Perimeter
2. Seal Lip
3. Inner Circumference of Front Diaphragm
4. Inner Surface of No.2 Body
5. Outer Circumference of No.2 Piston
6. Contact Surface of Piston Rod & Reaction Disc
7. Contact Surface of Reaction Disc & Operating Rod
8. Control Valve Perimeter
9. Piston Plate Perimeter
10. Reaction Disc Perimeter
11. O Ring
12. Contact Surface of Boot & No.2 Body
13. Contact Surface of No.1 Piston & Seal
14. Contact Surface of No.2 Piston & Seal & Bearing of No.3 body

(7.5 in. TANDEM TYPE : JKC)

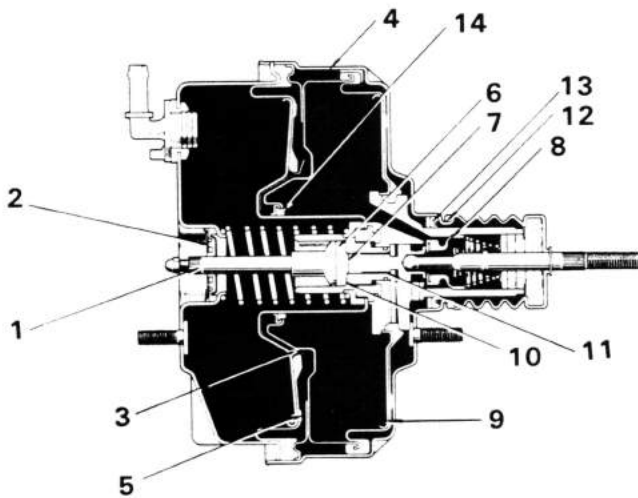

cardiagn.com

Fig. 9-142

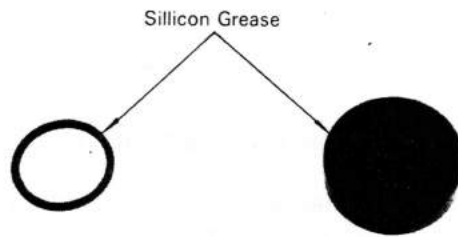

Coat the outer surface of the reaction disc and O ring with silicon grease.

Fig. 9-143

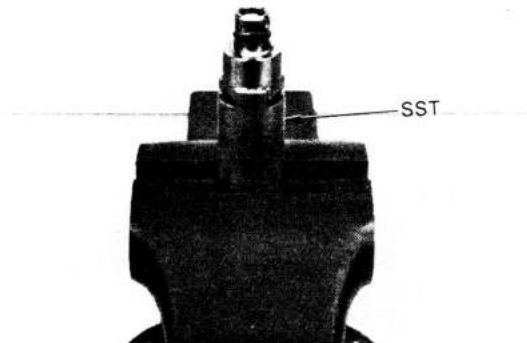

AISIN TYPE

Assemble the No.3 body

1. Clamp SST in a vise and install the reaction disc case.
SST [09753-30010]

Fig. 9-144

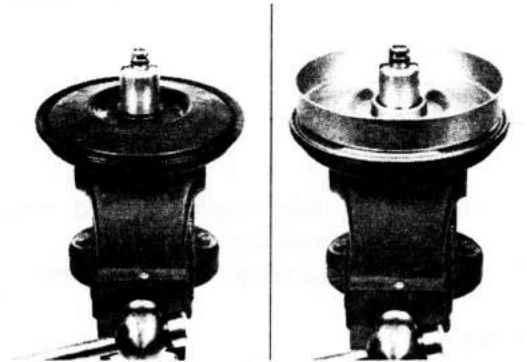

2. Install the front diaphragm and No.2 piston to the reaction disc case.
3. Install the No.3 body to the No.2 piston.

— Note —

1. Align the notched holes of the reaction disc case and No.2 piston in a right angle.
2. Coat the outer surface of the piston with silicon grease.

Fig. 9-145

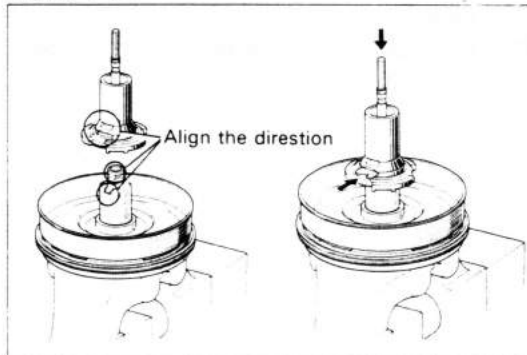

4. Push in the valve operating rod and valve stop key, and install the No.1 piston and No.2 piston.

— Note —

Align the reaction disc case, No.1 piston and No.2 piston in the same direction.

Fig. 9-146

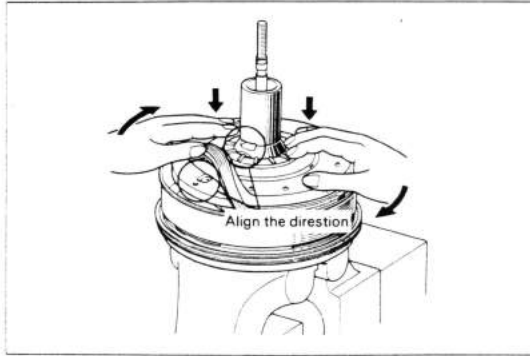

5. Install the rear diaphragm and piston plate.

- (1) When assembling, align the key hole of the No.1 piston with the round dent of the piston plate.
- (2) Of the 4 ribs, turn two diagonal ones clockwise to assemble.

Fig. 9-147

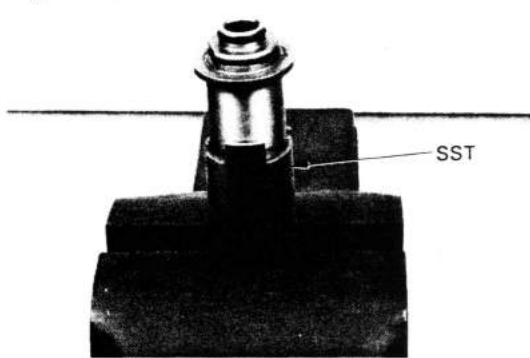

JKC TYPE

Assemble the No.3 body.

1. Clamp SST in a vise and install the reaction disc case.
SST [09753-30010]

Fig. 9-148

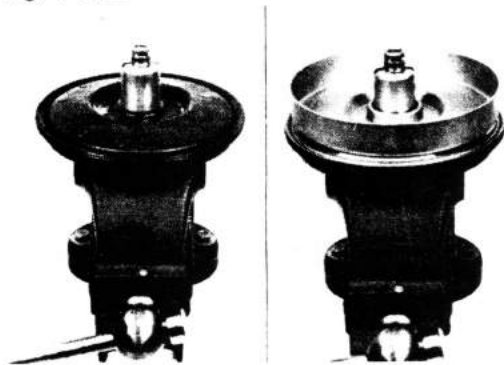

2. Install the front diaphragm and No.2 piston to the reaction disc case.
3. Install the No.3 body to the No.2 Piston.

— Note —

1. **Align the notched holes of the reaction disc case and No.2 piston in a right angle.**
2. **Coat the outer surface of the piston with silicon grease.**

Fig. 9-149



Install the retainer and clip as shown in the figure.

Fig. 9-150

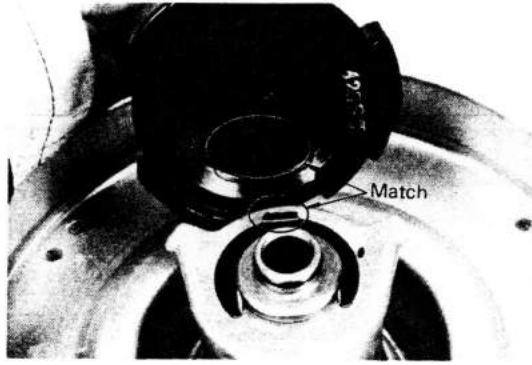

Match the hole and crip.

Fig. 9-151



AISIN TYPE

Install the No.2 body to the No.3 body assembly.

— Note —

Coat the inner surface of the No.2 body with silicon grease.

Fig. 9-152

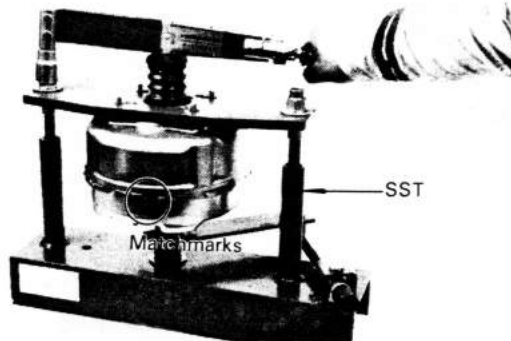

Install the No.1 body return spring, piston rod and No.2 body to SST and tighten the nut. SST [09738-00020]

**Tightening torque: 1.3 – 1.8 kg-m
(10 – 13 ft-lb)**

— Note —

1. Align the matchmarks on NO.1 body and No.2 body.
2. Tighten the both nuts evenly.

Fig. 9-153

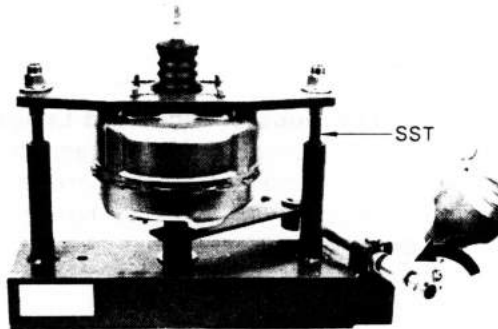

Assemble the body by turning the joint handle of the SST. SST [09738-00020]

INSTALLATION

Install the parts in the numerical order shown in the figure.

Fig. 9-154

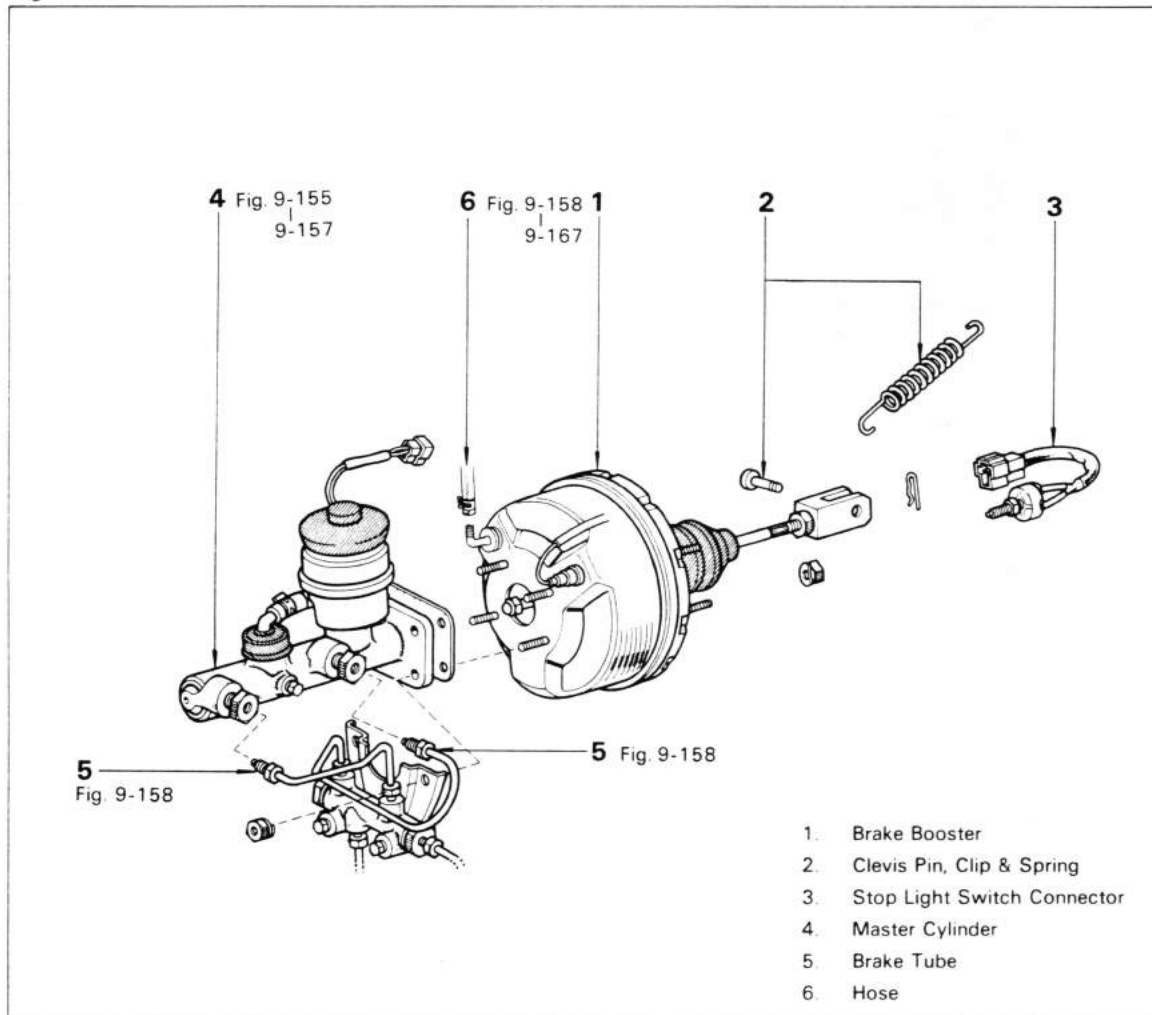
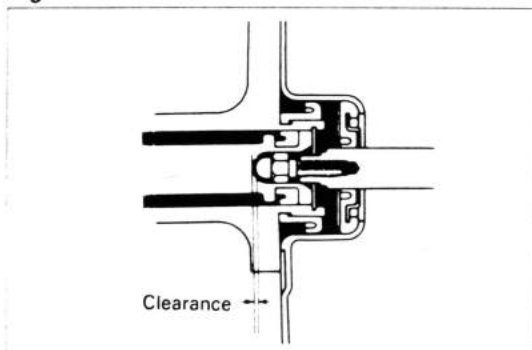

Fig. 9-155



Adjust The Booster Push Rod Length

The length of booster push rod is adjusted to provide the specified clearance between the push rod end and the master cylinder piston.

Clearance:

STD at Idling vacuum
 0.1 – 0.5 mm
 (0.004 – 0.020 in.)

Fig. 9-156

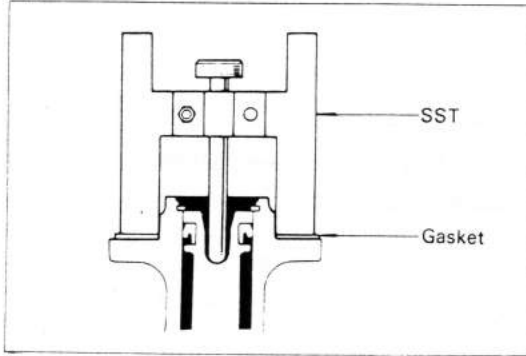

1. Set the SST on the master cylinder and push the pin until it contacts the piston.
SST [09737-00010]

—Note—

Measure the master cylinder together with the gasket.

Fig. 9-157

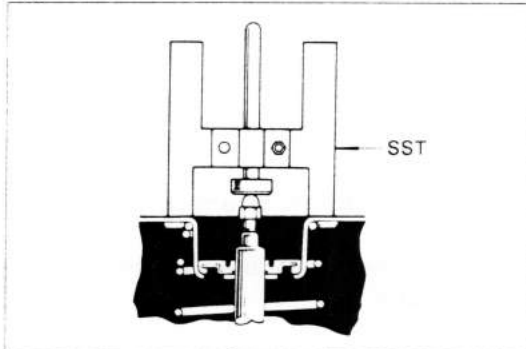

2. Turn the SST upside down and place it on the booster. Adjust the booster push rod length until the rod end contacts the pin head.

SST[09737-00010]

**Clearance: 0 mm
(0 in.)**

Between SST and push rod

3. Adjust push rod length.
4. By the above adjustment, the clearance will be 0.1 – 0.5 mm (0.004 – 0.020 in.) under the vacuum.

Fig. 9-158

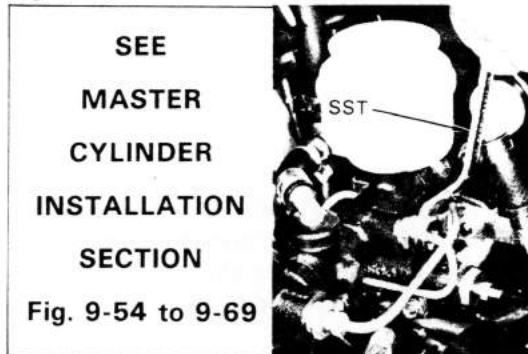

- Install the master cylinder and connect the brake tube with SST.
SST [09751-36011]

Fig. 9-159

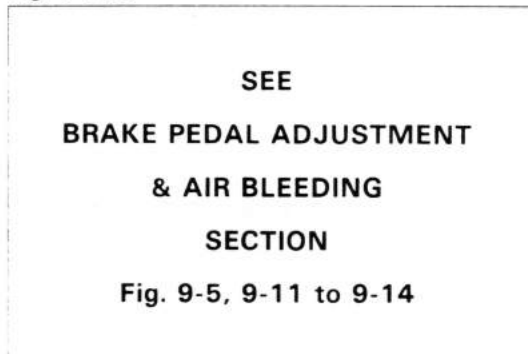

After installing, adjust the pedal height and play, and bleed air from the system.

Fig. 9-160

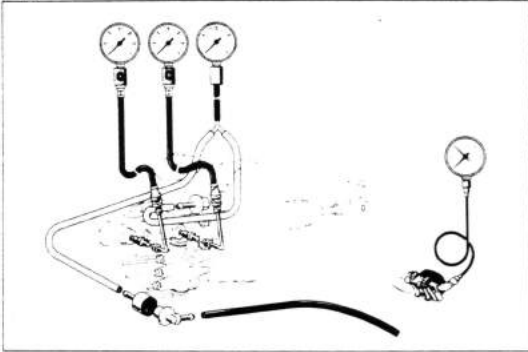
**ON-VEHICLE INSPECTION****Inspect Booster Operating**

Use the brake booster tester to inspect booster operating condition. If tester is not available check the brake booster by the following procedure. It is not necessary to pinpoint the exact place of trouble but sufficient to attain general knowledge of the condition.

Fig. 9-161

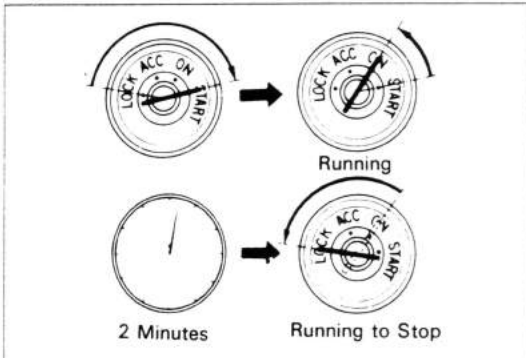
**Check The Air Tightness**

1. Start the engine.
2. Stop the engine after running for 1 or 2 minutes.

Fig. 9-162

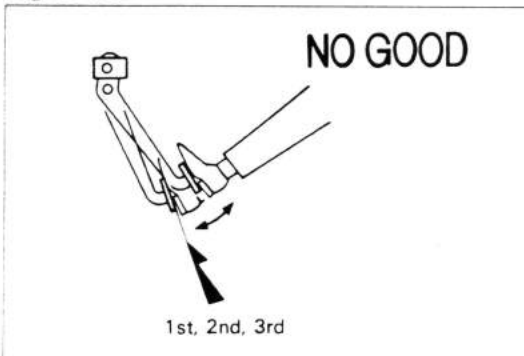

3. Pump the brake pedal several times. If the pedal goes down deep the 1st time but gradually rises after the 2nd and 3rd times, it is in good condition.

Fig. 9-163

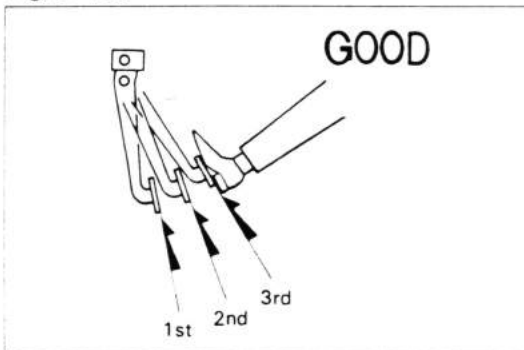

4. If there is no change in pedal height when depressed the 2nd and successive time, it is defective.

—Note—

If defective, inspect the vacuum lines and sealing parts, and replace any faulty part. When this has been done repeat the entire test!

Fig. 9-164

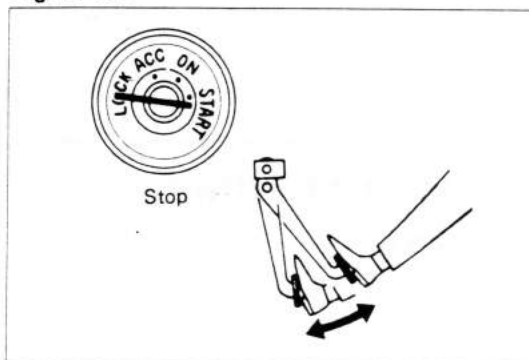
**Check The Operation**

1. With the engine stopped, pump the brake pedal several times with the same pressure. Insure that the pedal height does not change.

Fig. 9-165

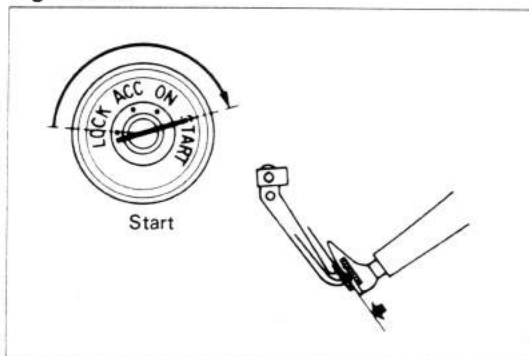

2. Start the engine while the brake pedal is depressed. If the pedal goes down slightly at this time, it is in good condition. If there is no change in pedal height, it is defective.

Fig. 9-166

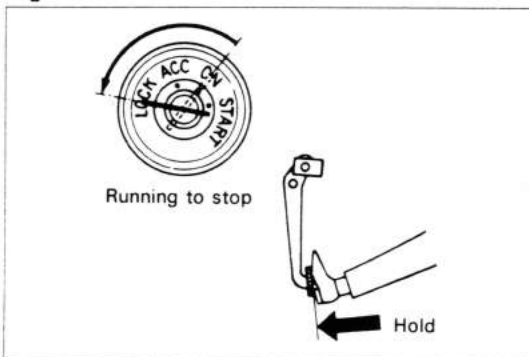
**Check The Air Tightness Under The Load**

1. With the engine running, depress the brake pedal. Then stop the engine while keeping the brake pedal depressed.

Fig. 9-167

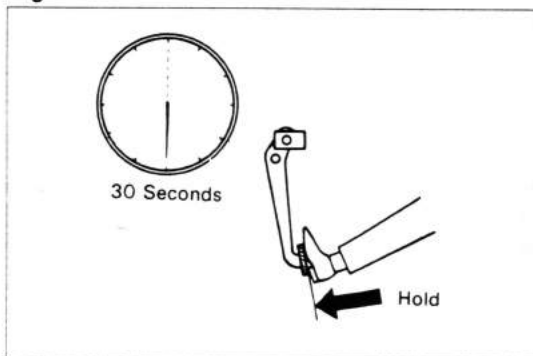

2. Hold depressed for 30 seconds. If the pedal height does not change, it is in good condition. If the pedal rises, it is defective.

VACUUM PUMP

REMOVAL

Remove the parts in the numerical order shown in the figure.

Fig. 9-168

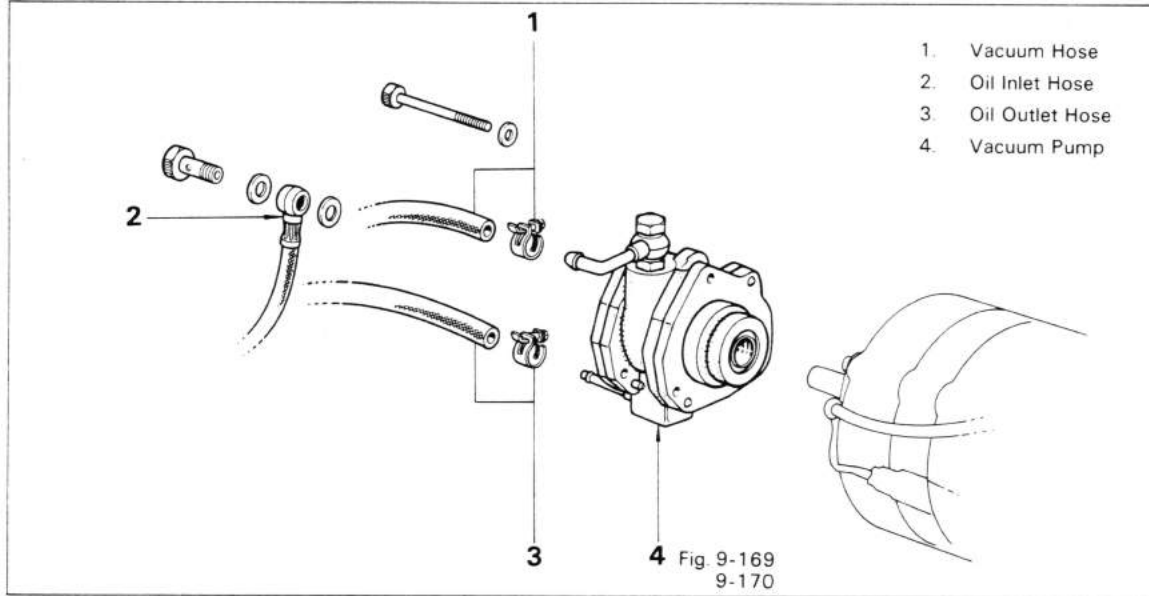
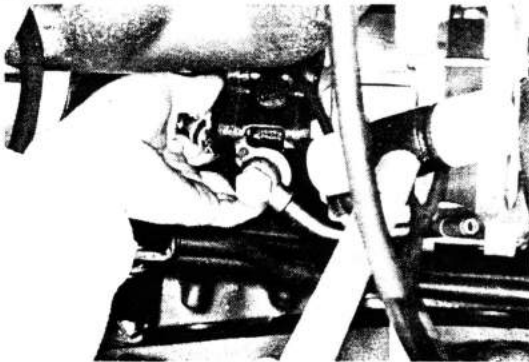

Fig. 9-169



Tap the pump with a plastic hammer until there is a clearance between it and the alternator surface.

Fig. 9-170



Pry with a screwdriver and remove the vacuum pump.

DISASSEMBLY

Disassemble the parts in the numerical order shown in the figure.

Fig. 9-171

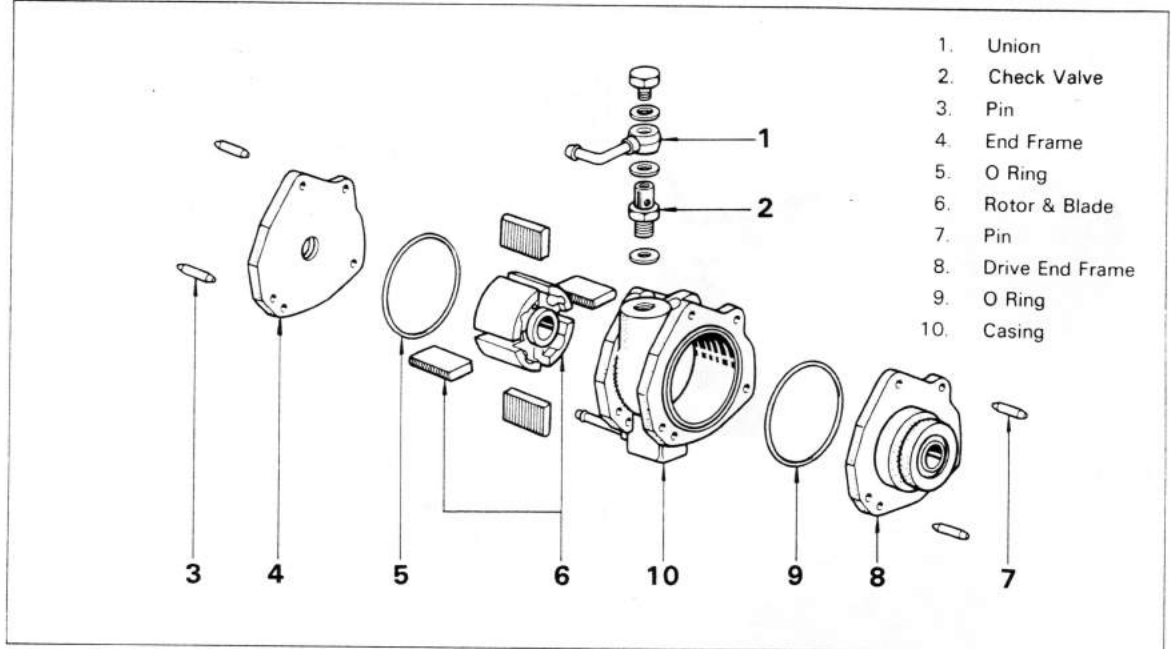

Fig. 9-172

**INSPECTION & REPAIR****Casing**

Inspect for wear or damage.

Fig. 9-173

**End Frame**

Inspect for wear or damage.

Fig. 9-174

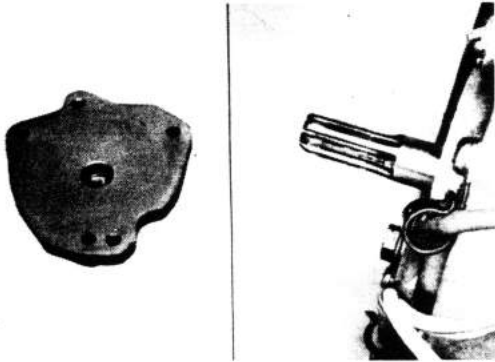

Bushing & Shaft

Inspect for wear or damage.

Bushing bore diameter:

**Limit 16.14 mm
(0.6354 in.)**

Fig. 9-175

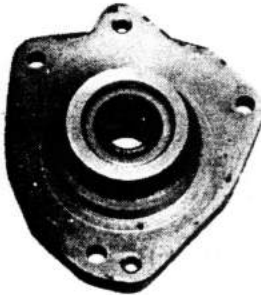

Oil Seal

Inspect for wear or damage.

Fig. 9-176

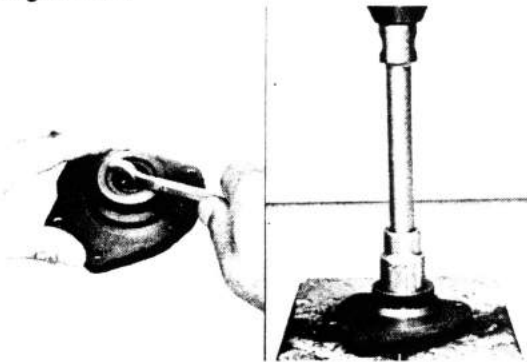

Replace The Oil Seal

1. Remove the oil seal.
2. Drive in the oil seal with a socket wrench.



Fig. 9-177

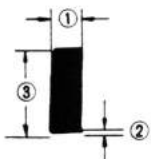

Blade

Inspect for wear or damage.

mm (in.)

Item	Series	2H, B
①	Height limit	11.6 (0.457)
②	Width limit	6.9 (0.272)
③	Length limit	34.9 (1.374)

Fig. 9-178

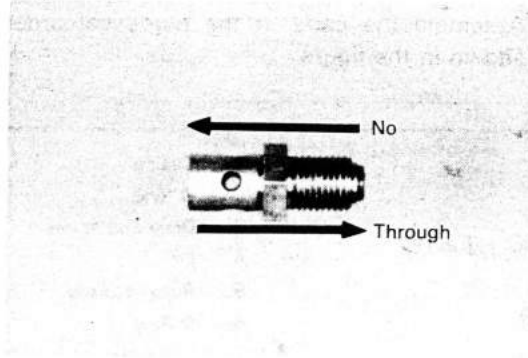

Check Valve

Check to see that the lead is in the direction shown in the figure.

Fig. 9-179

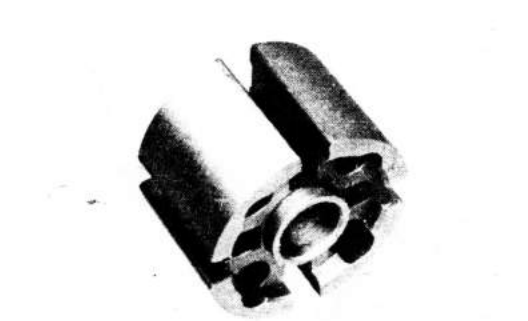

Rotor

1. Inspect for wear or damage.

Fig. 9-180

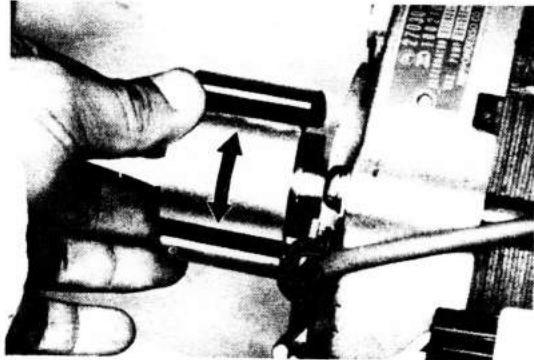

2. Inspect the rotor play.

Wear:

**Limit 2.4 mm
(0.094 in.)**

Fig. 9-181

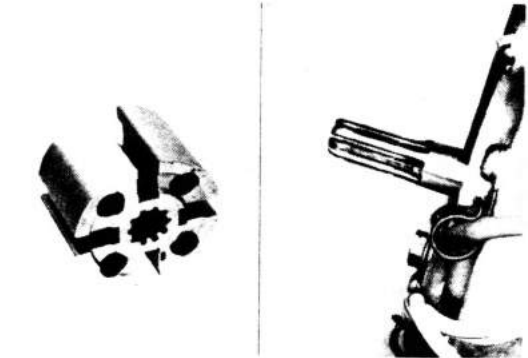

Spline

Inspect for wear or damage.

ASSEMBLY

Assemble the parts in the numerical order shown in the figure.

Fig. 9-182

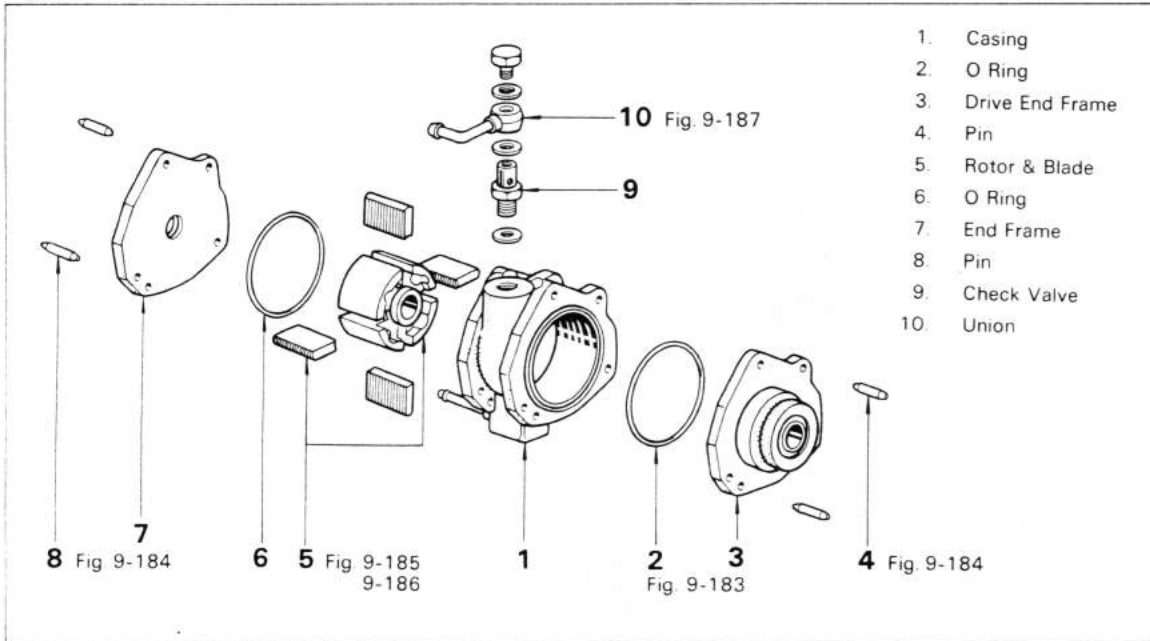

Fig. 9-183



Use new O ring.

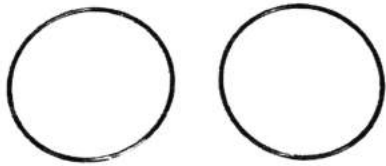

Fig. 9-184



Strike out 5 mm (0.20 in.)

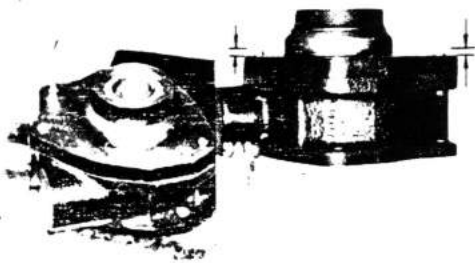

Fig. 9-185



Face the rounded side toward the outside.

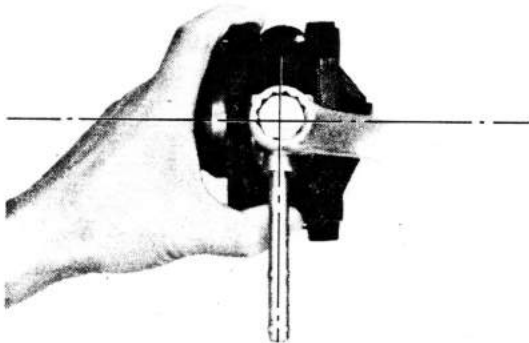

Fig. 9-186



Be sure that the blade and rotor surfaces are even.

Fig. 9-187



Face the union in the direction shown in the figure.

**Tightening torque: 1.2 – 1.6 kg-m
(9 – 11 ft-lb)**

INSTALLATION

Install the parts in the numerical order shown in the figure.

Fig. 9-188

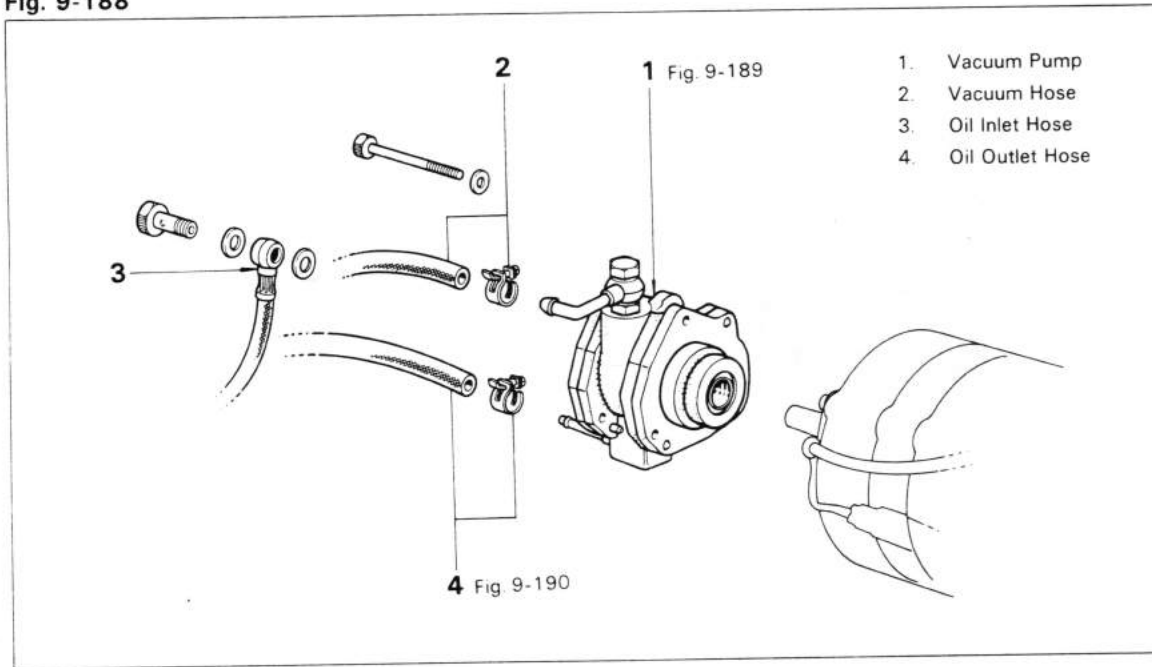
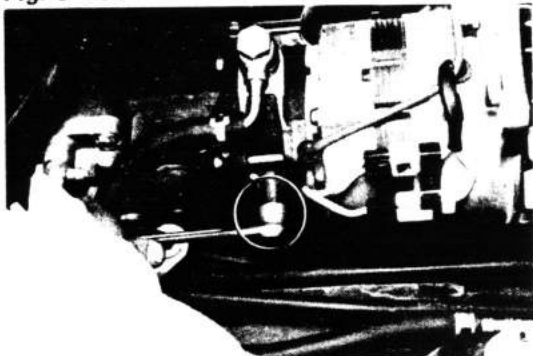

Fig. 9-189



Apply MP grease to the oil seal lip.

Fig. 9-190



While the engine is idling, loosen the outlet union bolt and confirm that oil leaks out.

FRONT BRAKE (DRUM TYPE)

REMOVAL

Remove the parts in the numerical order shown in the figure.

Fig. 9-191

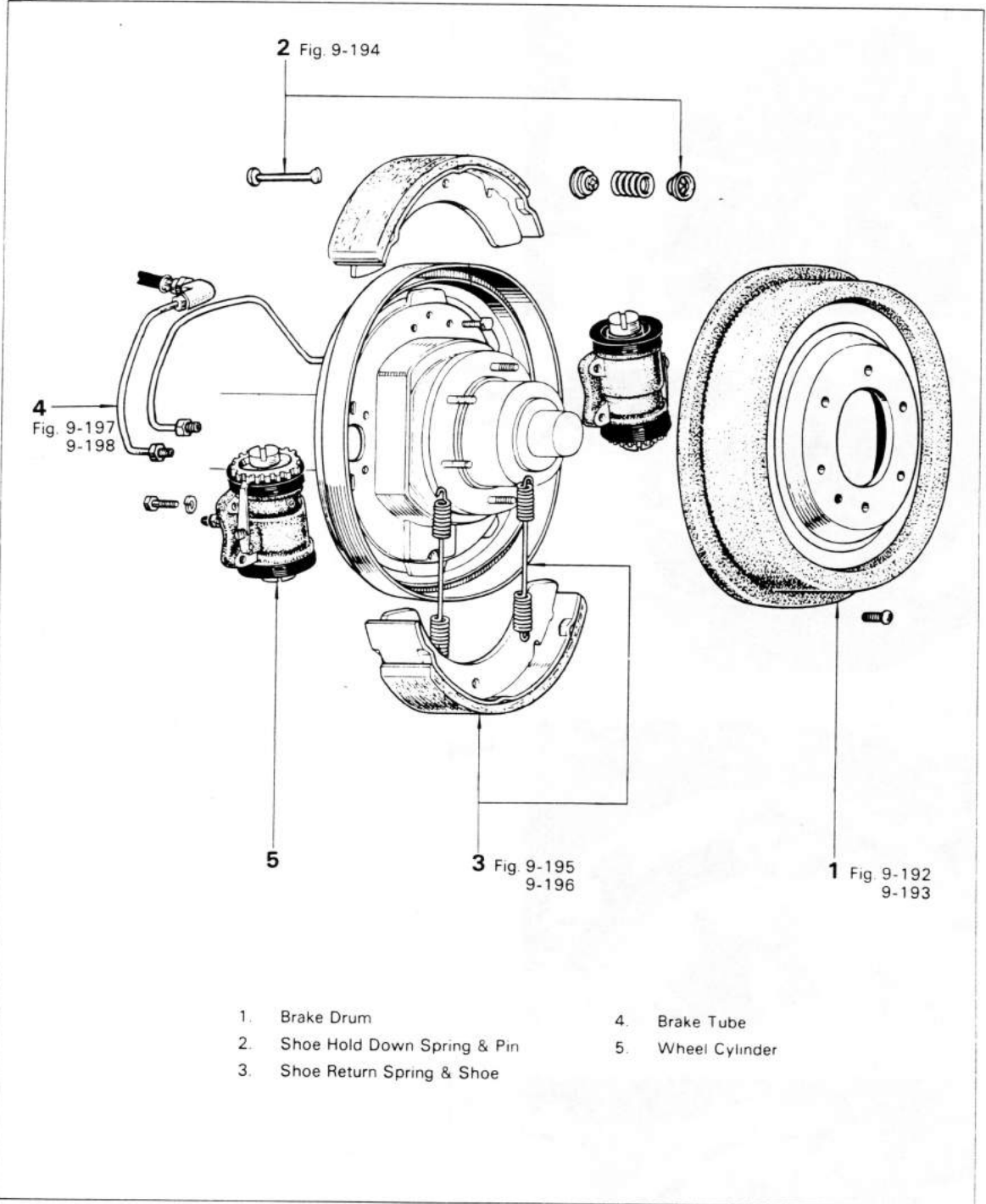

- | | |
|--------------------------------|-------------------|
| 1. Brake Drum | 4. Brake Tube |
| 2. Shoe Hold Down Spring & Pin | 5. Wheel Cylinder |
| 3. Shoe Return Spring & Shoe | |

Fig. 9-192

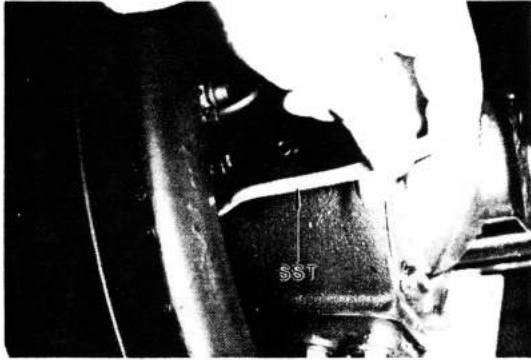

Return the wheel cylinder adjusting nut with SST.
SST [D9704-10010]

Fig. 9-193

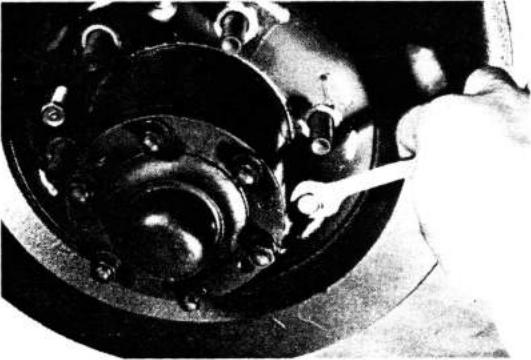

Remove the drum by screwing service bolt.

Fig. 9-194

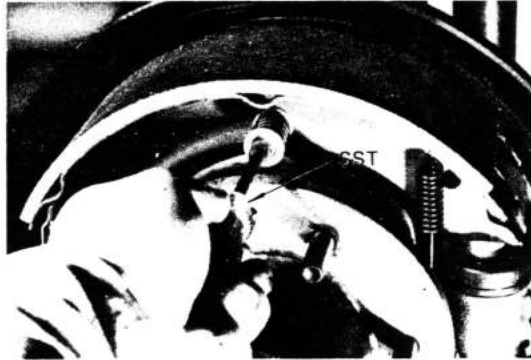

Remove the snap ring with SST.
SST [09718-00010]

Fig. 9-195



Remove the shoes and return spring
1. Remove the shoes from the adjusting nut side first.

—Note—
Do not damage the boots.

Fig. 9-196

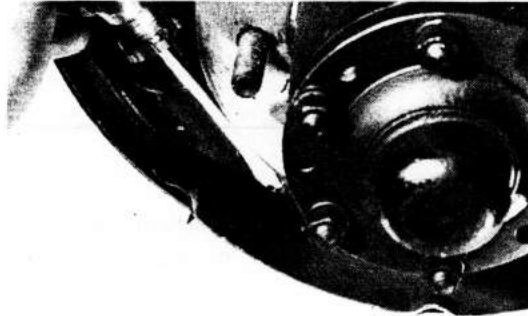

2. Remove the shoe return spring with driver.

Fig. 9-197

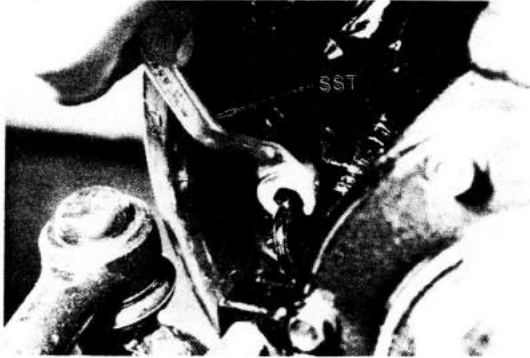

Loosen the union nut with SST.
SST [09751-36011]

Fig. 9-198

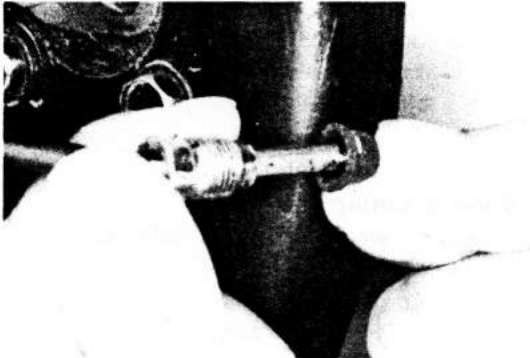

Assemble the bleeder plug cap to the brake tube.

Fig. 9-199

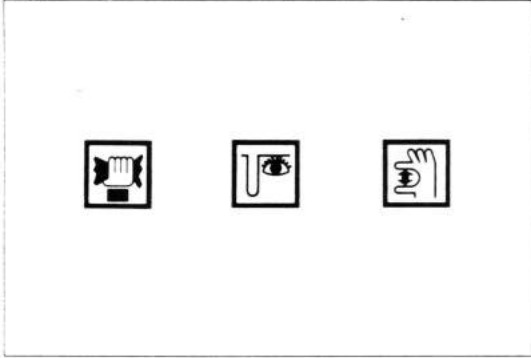
**INSPECTION**

Inspect the disassembled parts on the following points and repair or replace parts if necessary.

Fig. 9-200

**Spring & Pin**

Inspect for damage or deformation.

Fig. 9-201

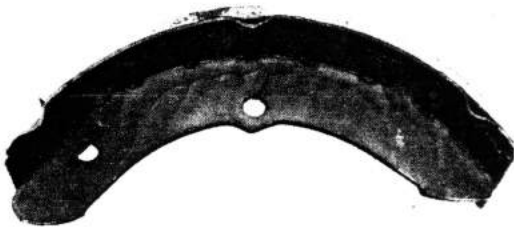
**Shoe & Lining**

Inspect for wear, damage or deformation.

Lining thickness:

Limit 1.5 mm
(0.059 in.)

Fig. 9-202

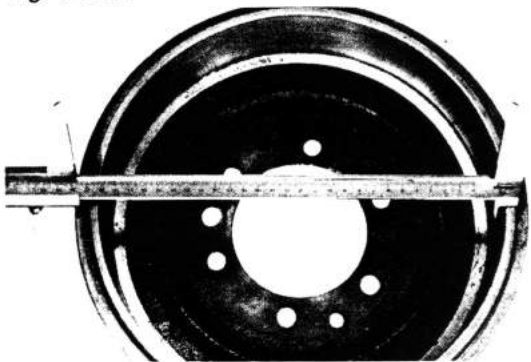
**Brake Drum**

Inspect for wear, damage or cracks.

Drum inner diameter:

STD 295 mm
(11.61 in.)
Limit 297 mm
(11.69 in.)

Fig. 9-203

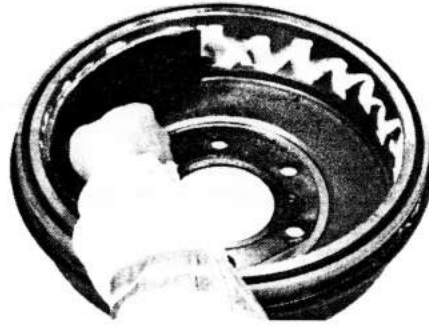

Inspect the brake lining and drum for proper contact.

Fig. 9-204

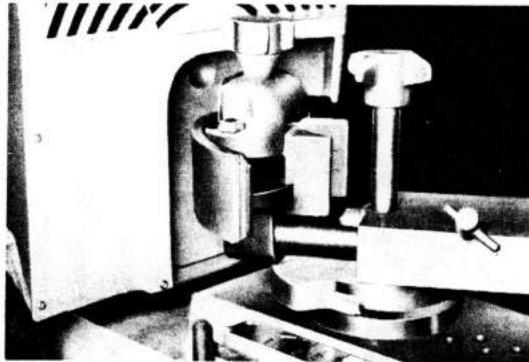

If the contact between brake lining and drum is improper, repair the lining with a brake shoe grinder, or replace the brake shoe assembly.

Fig. 9-205



Wheel Cylinder

1. Inspect the cups for damage or deformation.
2. Inspect the boots for damage or cracks.
3. Inspect the cylinder body bore and piston for wear, damage, rust, or corrosion.
4. Inspect the adjusting nut and bolt for damage or deformation.

Fig. 9-206

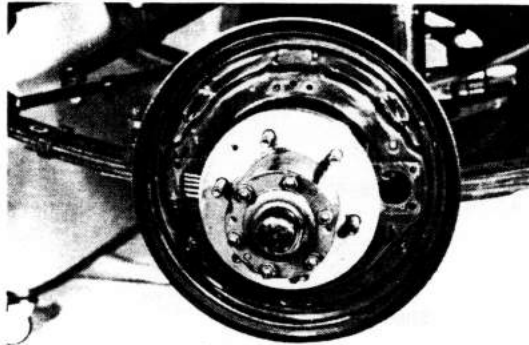

Backing Plate

Inspect for damage, cracks, or deformation. For removal and installation, refer to the Front Axle section installation.

INSTALLATION

Install the parts in the numerical order shown in the figure.

Fig. 9-207

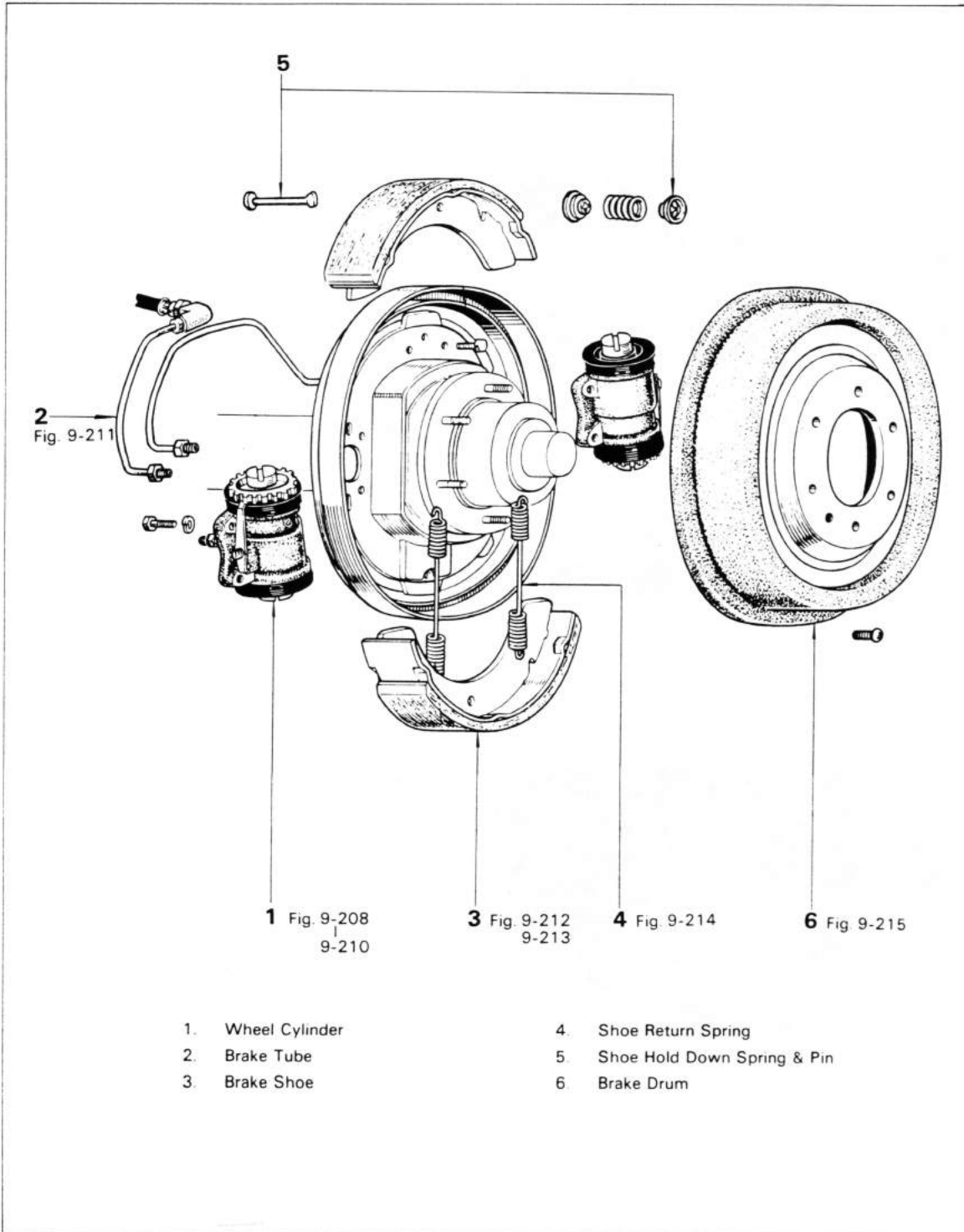

- 1. Wheel Cylinder
- 2. Brake Tube
- 3. Brake Shoe

- 4. Shoe Return Spring
- 5. Shoe Hold Down Spring & Pin
- 6. Brake Drum

Fig. 9-208

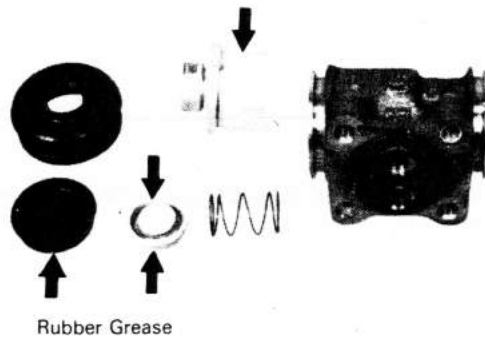

Coat the piston and cup with rubber grease.

Fig. 9-209

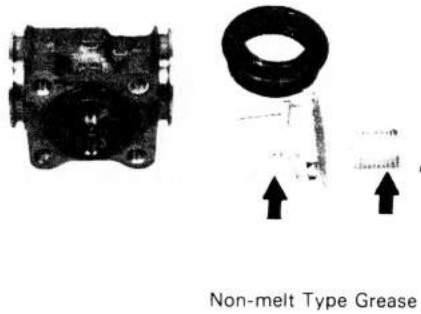

Coat the adjusting nut and bolt with non-melt type grease.

Fig. 9-210

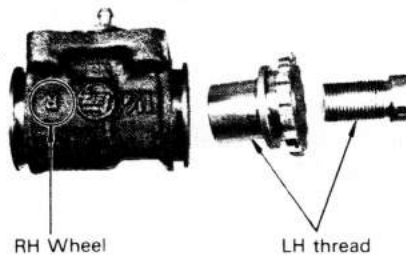

Install the left hand thread adjusting nut and bolt at the RH wheel brake.

Fig. 9-211

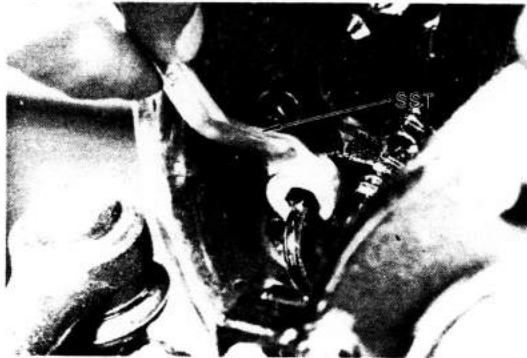

Tighten the union nut with SST.
SST [09751-36011]

Tightening torque: 1.3-1.8 kg-m
(10-13 ft-lb)

Fig. 9-212

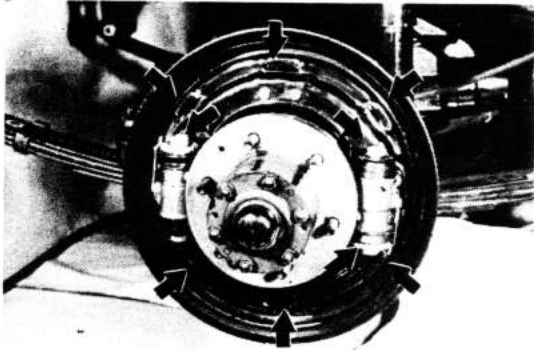

Apply non-melt type grease to the place indicated by the arrow.

Fig. 9-213

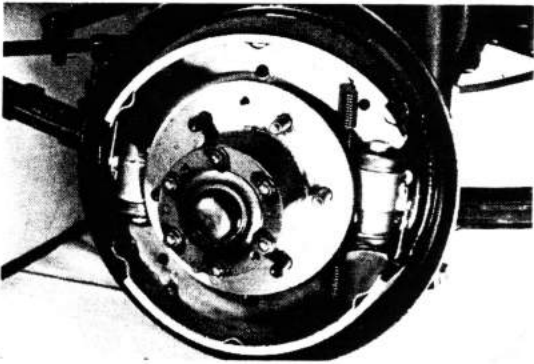

Install the shoe return spring as shown in the figure.

Fig. 9-214

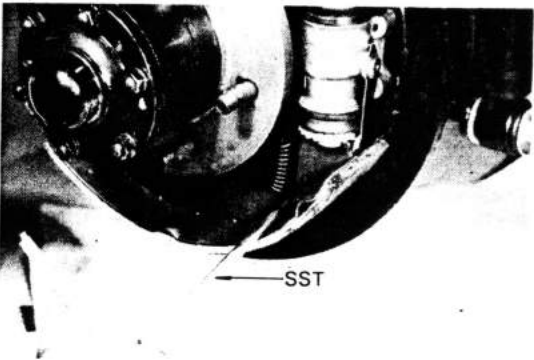

Install the rear side return spring to the outer side with SST.
SST [09703-30010]

Fig. 9-215

SEE
AIR BLEEDING & BRAKE
SHOE CLEARANCE
ADJUSTMENT SECTION
Fig. 9-5, 9-11 to 9-14

Bleed the air from the system.
Adjust the brake shoe clearance with SST.
SST [09704-10010]

FRONT BRAKE (DISC TYPE)**BRAKE PAD****REMOVAL**

Remove the parts in the numerical order shown in the figure.

Fig. 9-216

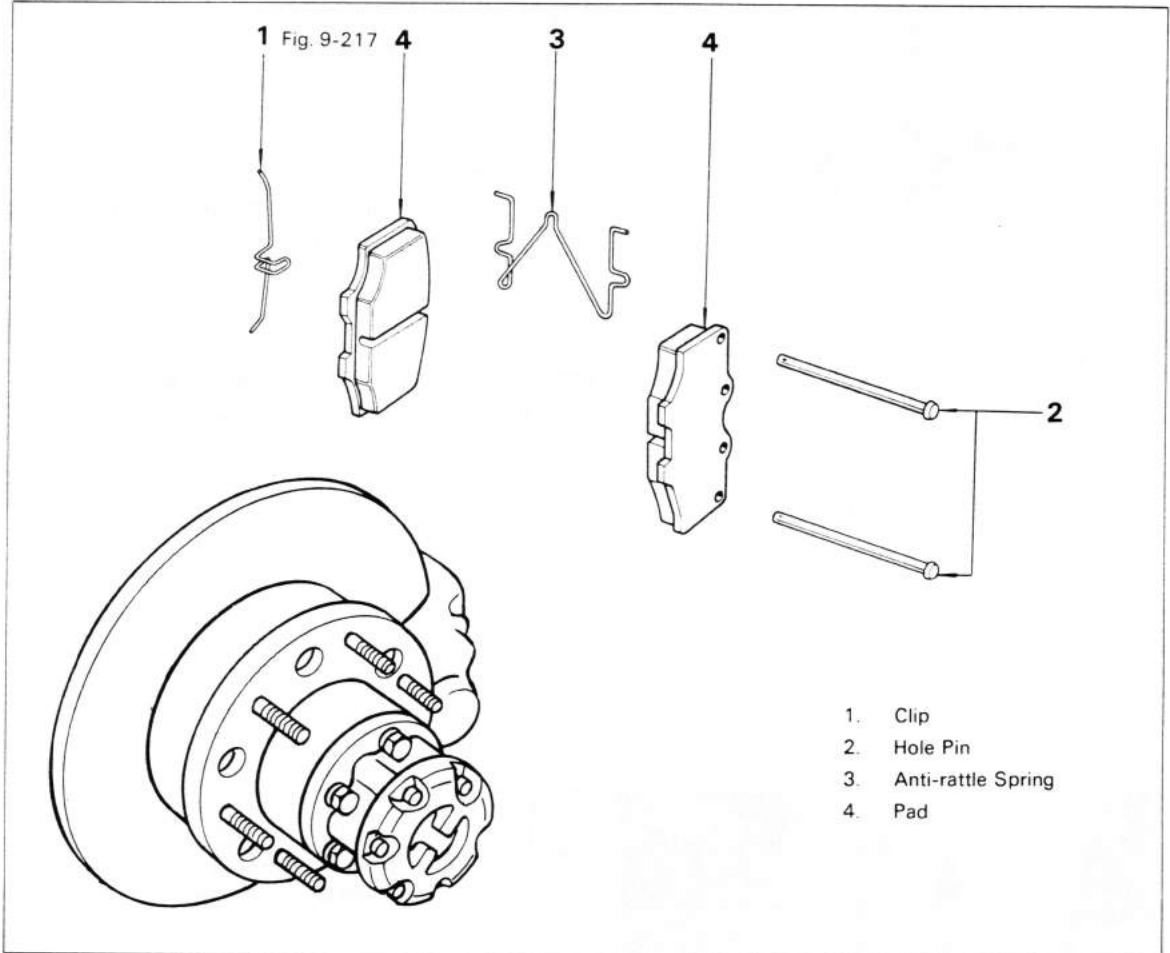
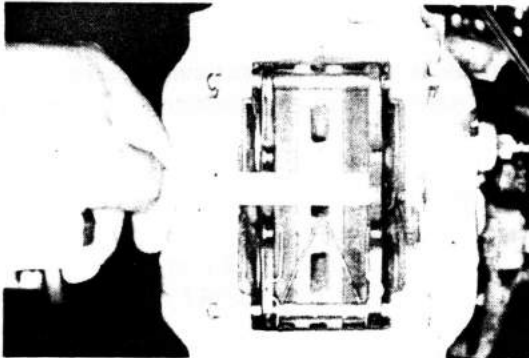

Fig. 2-217



Check the brake pad thickness.

Brake pad lining thickness:

**Limit 1.0 mm
(0.039 in.)**

Fig. 9-218

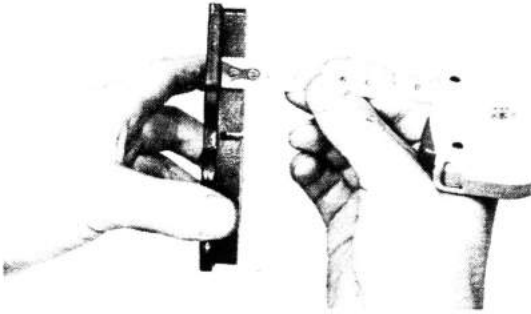
**INSPECTION****Brake Pad**

Measure the lining thickness.

Lining thickness:

Limit 1.0 mm
(0.039 in.)

—Note—

Replace pads when the lining has one-sided or uneven wear.

Fig. 9-219

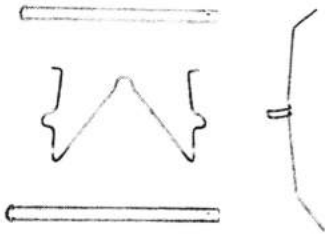
**Anti-rattle Spring, Hole Pin & Clip**

Inspect for damage or weakening.

Fig. 9-220

**Disc**

1. Measure the disc thickness.

Disc thickness:

STD 20 mm
(0.79 in.)

Limit 19 mm
(0.75 in.)

—Note—

Check the lining contact surfaces for scoring. Repair or replace the disc as necessary.

Fig. 9-221

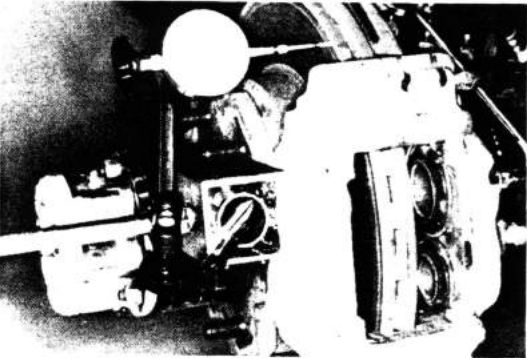

2. Measure the disc runout.

Runout:

Limit 0.12 mm
(0.0047 in.)

—Note—

Check the looseness of the front wheel bearing before measurement.

INSTALLATION

Install the parts in the numerical order shown in the figure.

Fig. 9-222

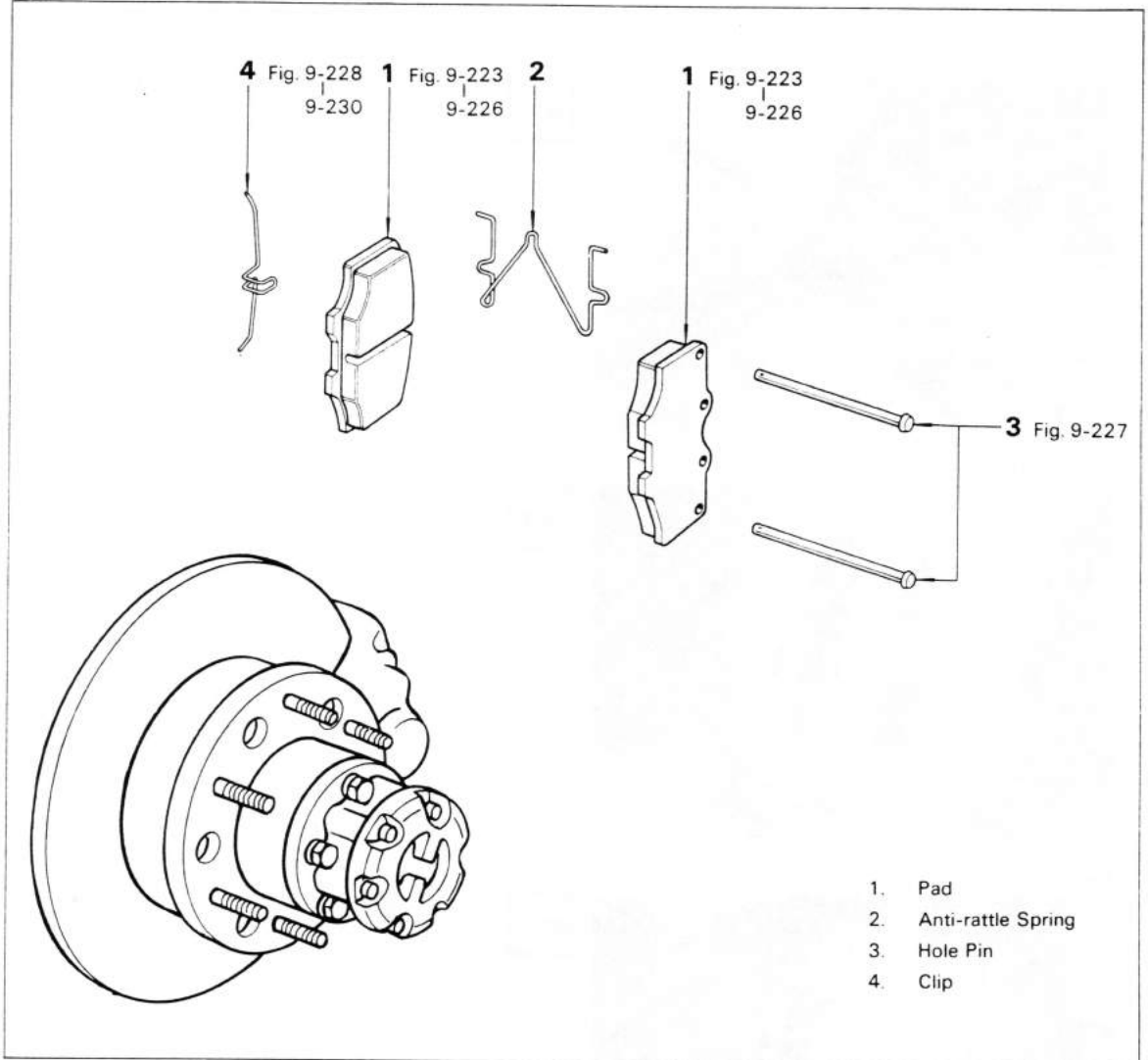
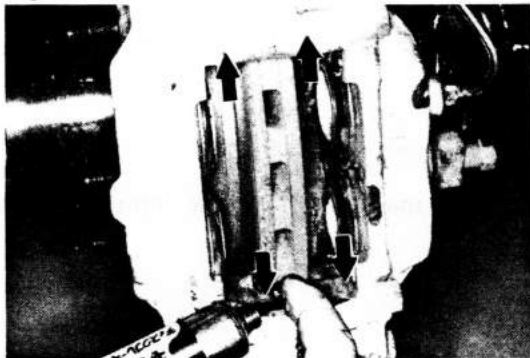
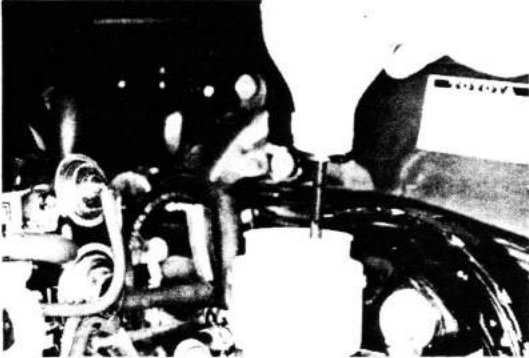

Fig. 9-223



Coat disc brake grease on the disc brake cylinder that the pads slide on.

Fig. 9-224



Draw out a small amount of brake fluid from the reservoir.

Fig. 9-225

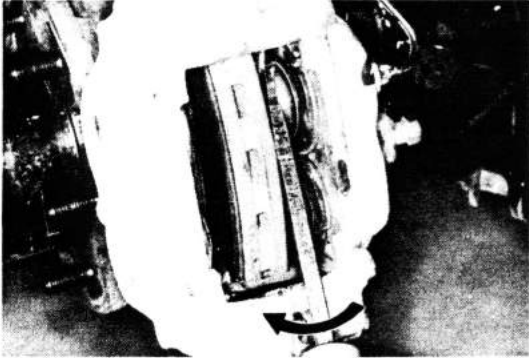

Push both pistons into the cylinder.

Fig. 9-226

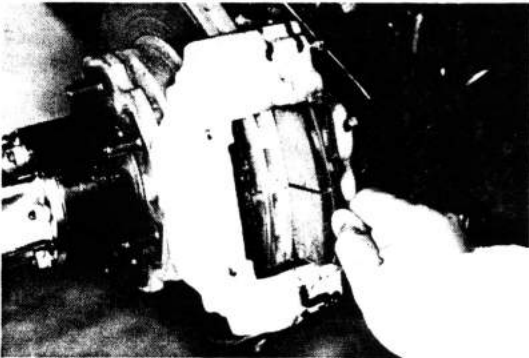

Install the pads.

Fig. 9-227

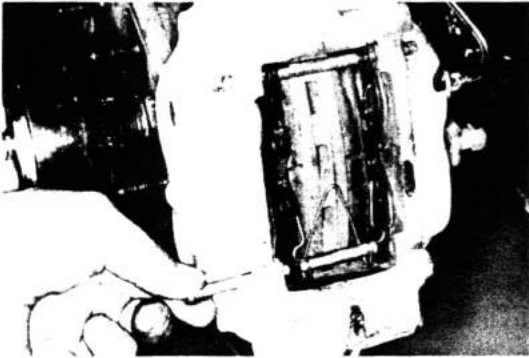

Install the pins through the anti-rattle spring.

Fig. 9-228

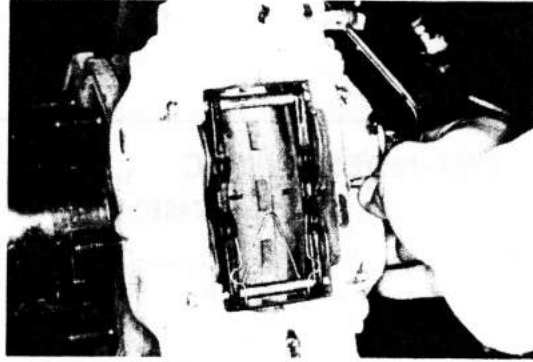

Install the clip.

Fig. 9-229

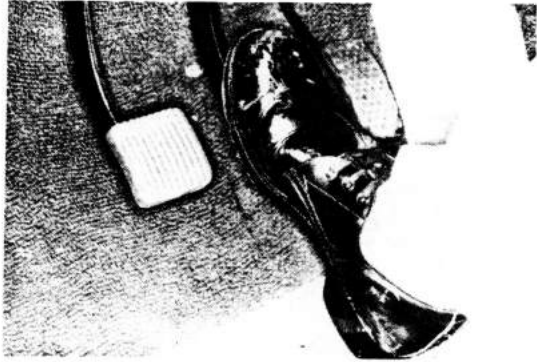

Depress the brake pedal.

Fig. 9-230

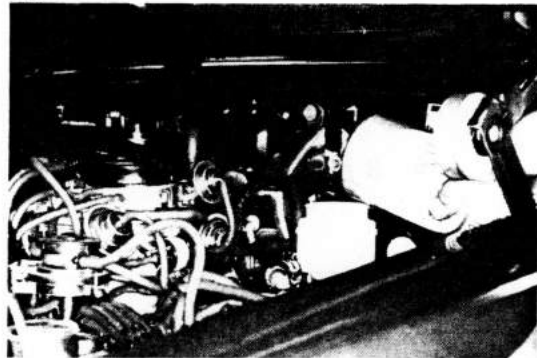

Replenish the brake fluid to the MAX line.

**CYLINDER & DISC
REMOVAL & DISASSEMBLY**

Remove and disassemble the parts in the numerical order shown in the figure.

Fig. 9-231

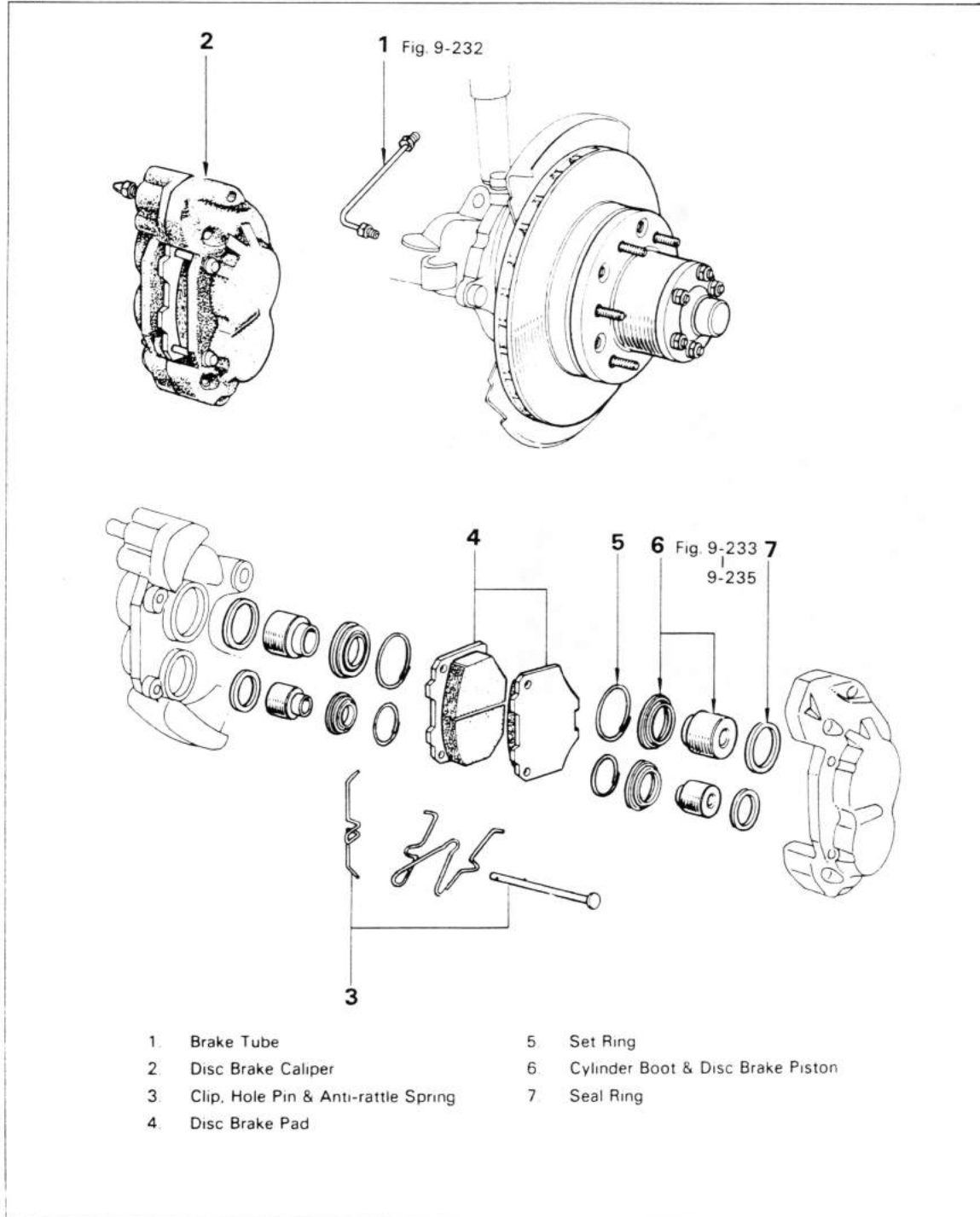
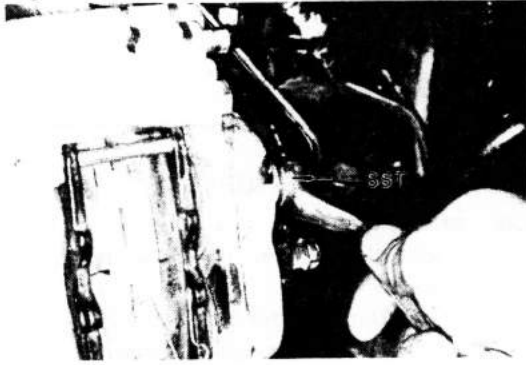

Fig. 9-232



Disconnect the brake tube with SST.
SST [09751-36011]

—Note—

After disconnecting, install the air bleeder cap to the tube.

Fig. 9-233

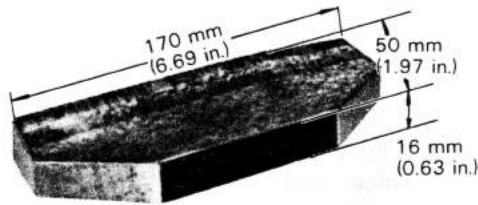

As shown in the figure, place a backing board into the caliper slot, and insert a pad at one side.

Fig. 9-234

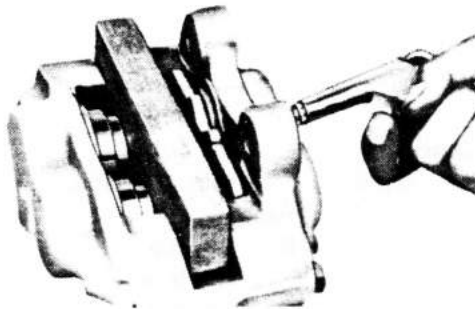

Remove the pistons one at a time by compressed air.

Fig. 9-235

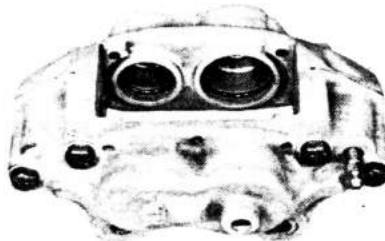

—Caution—

1. Do not loosen the caliper bolts.
2. Do not separate the caliper.

Fig. 9-236

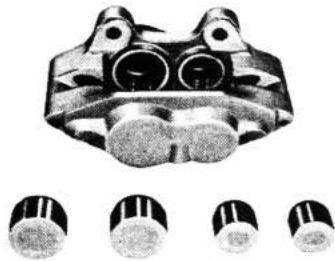
**INSPECTION & REPAIR****Caliper & Piston**

1. Inspect the caliper for deformation or cracks.
2. Inspect the cylinder bore and piston for eccentric wear, damage or corrosion.

Fig. 9-237

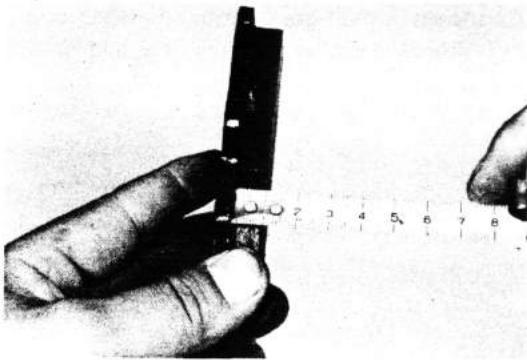
**Pad**

Inspect for thickness and one-sided wear.

Thickness:

STD	at lining
	10 mm (0.39 in.)
Limit	at lining
	1.0 mm (0.039 in.)

Fig. 9-238

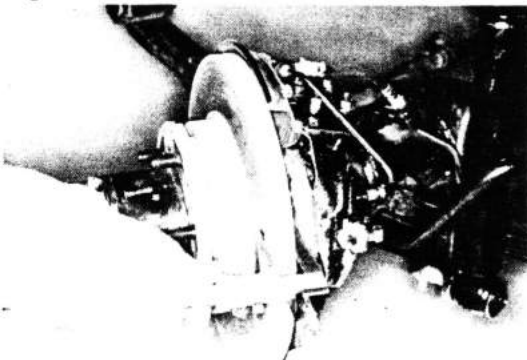
**Disc**

1. Inspect for thickness and runout.

Thickness:

STD	20 mm
	(0.79 in.)
Limit	19 mm
	(0.75 in.)

Fig. 9-239

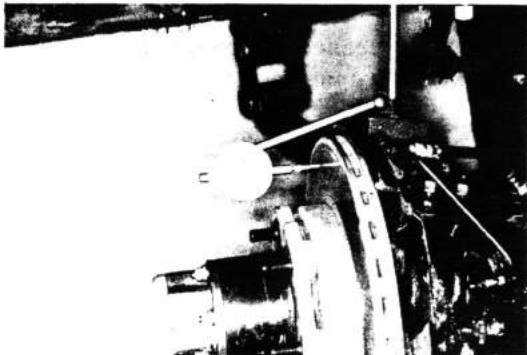
**Runout:**

Limit	0.12 mm
	(0.0047 in.)

—Note—

There must not be any excessive looseness in the front wheel bearings when the runout is measured.

INSTALLATION

Install the parts in the numerical order shown in the figure.

Fig. 9-240

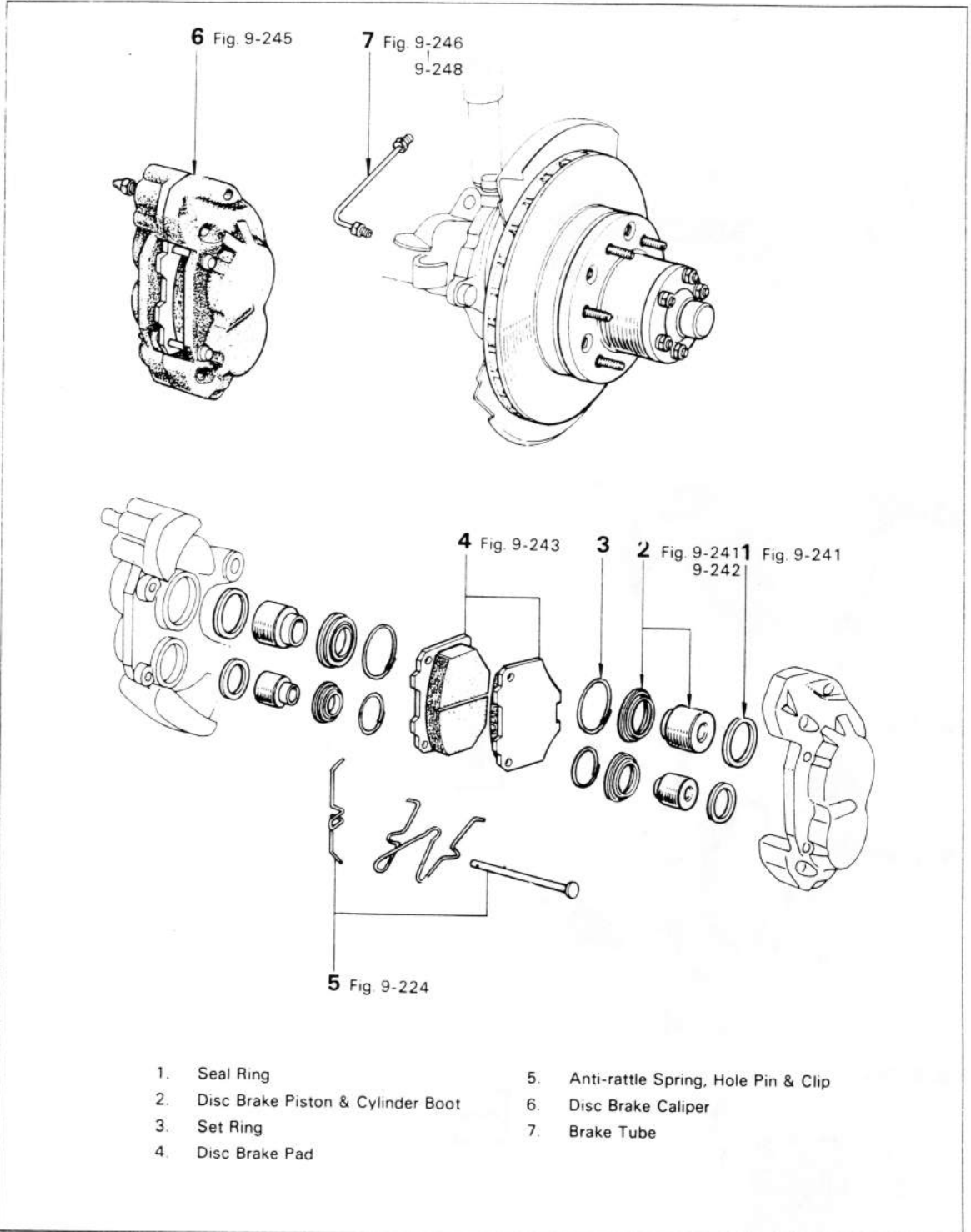

- | | |
|--------------------------------------|--|
| 1. Seal Ring | 5. Anti-rattle Spring, Hole Pin & Clip |
| 2. Disc Brake Piston & Cylinder Boot | 6. Disc Brake Caliper |
| 3. Set Ring | 7. Brake Tube |
| 4. Disc Brake Pad | |

Fig. 9-241

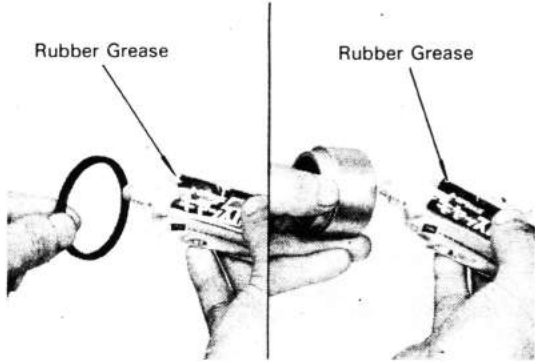

Apply rubber grease to the new seal and the piston.

Fig. 9-242

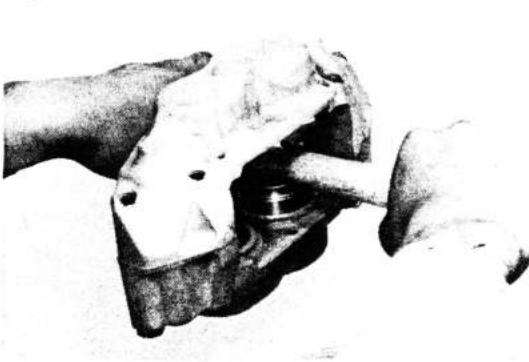

Do not pry the piston into the cylinder.

Fig. 9-243

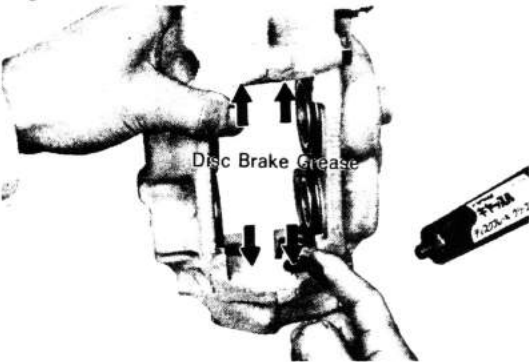

Coat disc brake grease on the disc cylinder that the pads slide on.

Fig. 9-244

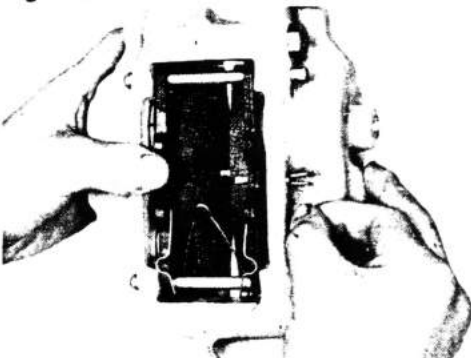

Install the clip.

Fig. 9-245

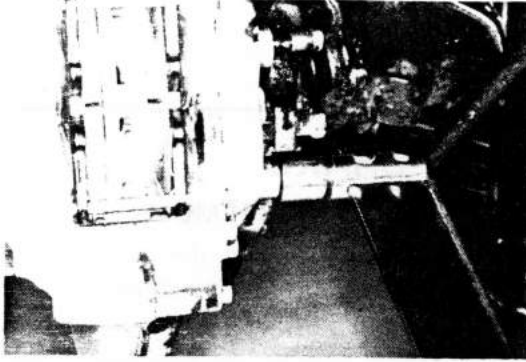

Tighten the caliper mounting bolts

Tightening torque: 10.0–15.0 kg-m
(73–108 ft-lb)

Fig. 9-246

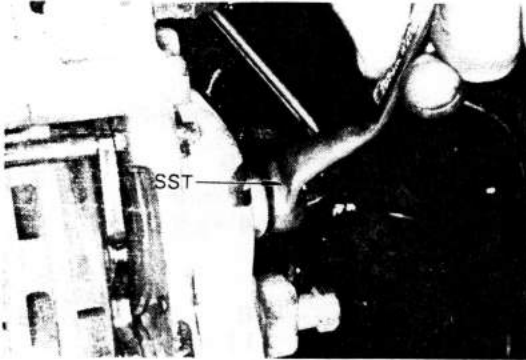

1. Connect the brake tube to the caliper with SST.

SST [09751-36011]

Tightening torque:

1.3 – 1.8 kg-m
(10 – 13 ft-lb)

Fig. 9-247

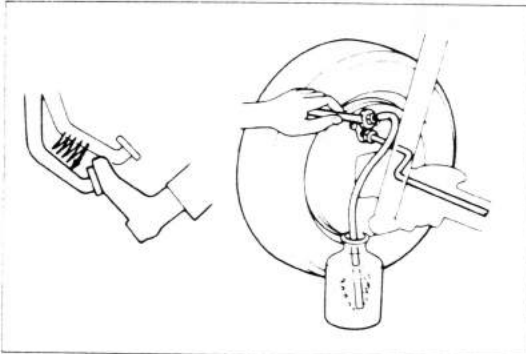

2. Bleed the air from the system.

Fig. 9-248

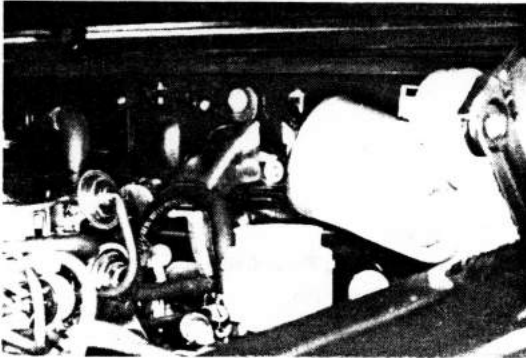

3. Replenish the brake fluid to the MAX line.

REAR BRAKE

REMOVAL & DISASSEMBLY

Remove and disassemble the parts in the numerical order shown in the figure.

Fig. 9-249

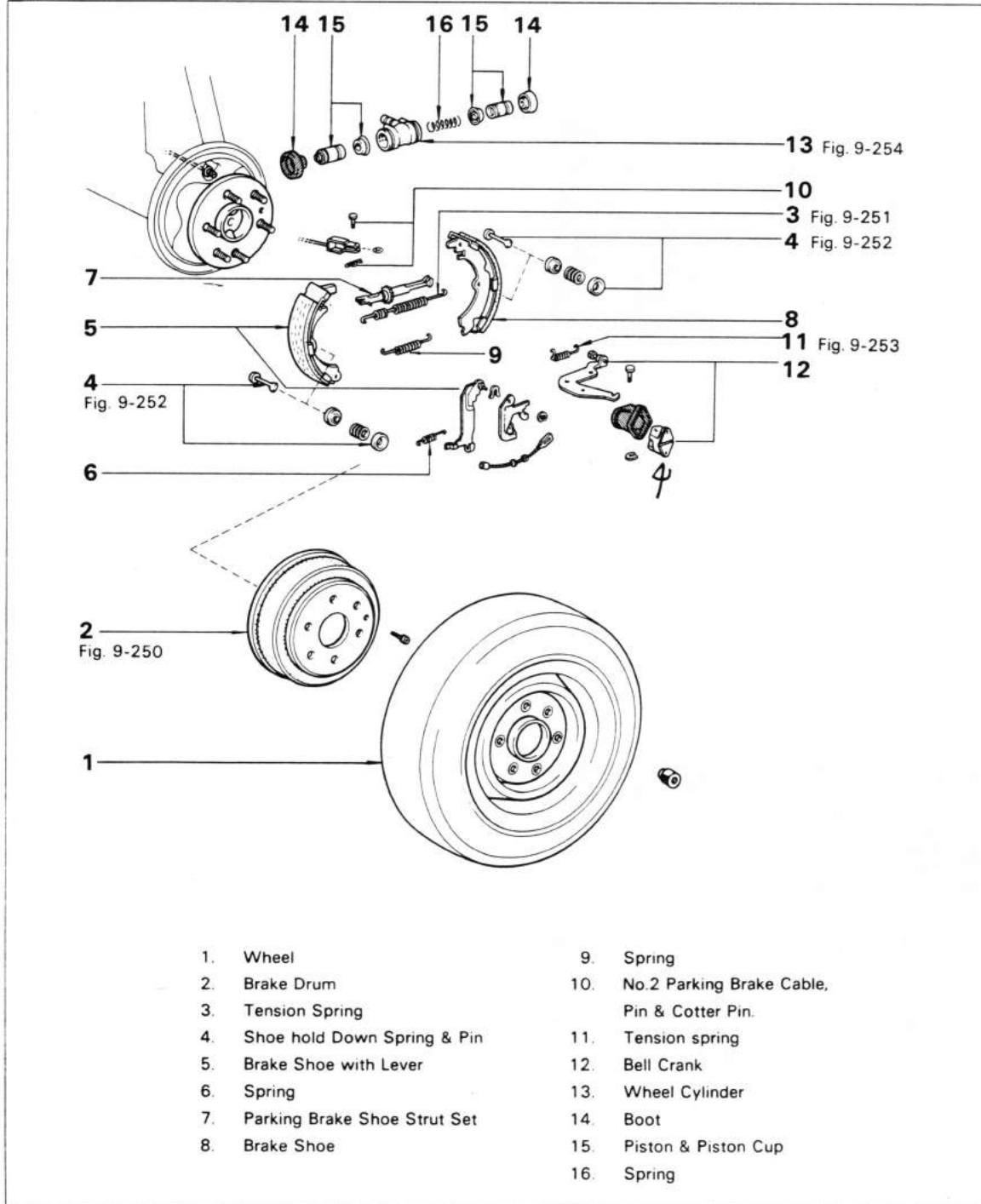

cardiagn.com

Fig. 9-250

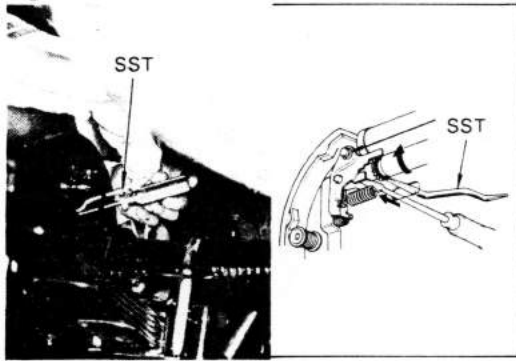

The drum may be difficult to remove because of little clearance between it and the shoe. Always allow sufficient clearance before drum removal.

1. Push back the automatic adjuster lever with a screwdriver.
2. Shorten the adjuster with SST. SST [09704-10010]

Fig. 9-251

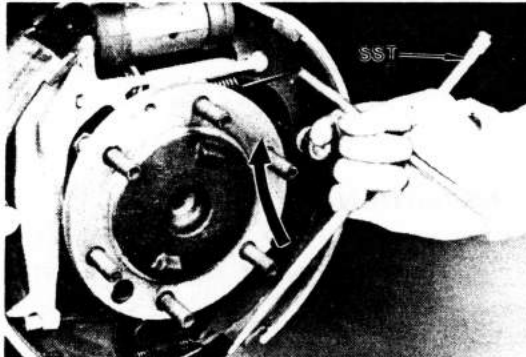

Remove the tension spring with SST. SST [09703-30010]

Fig. 9-252

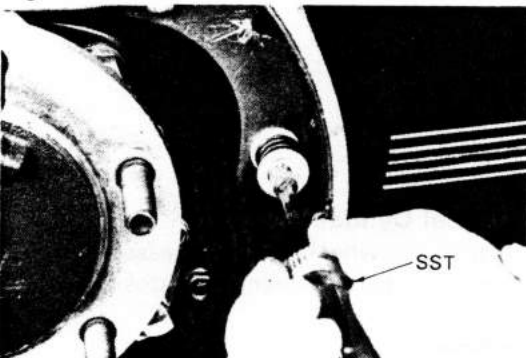

Remove the shoe hold down spring with SST. SST [09718-00010]

Fig. 9-253



Remove the tension spring from the bell crank.

Fig. 9-254

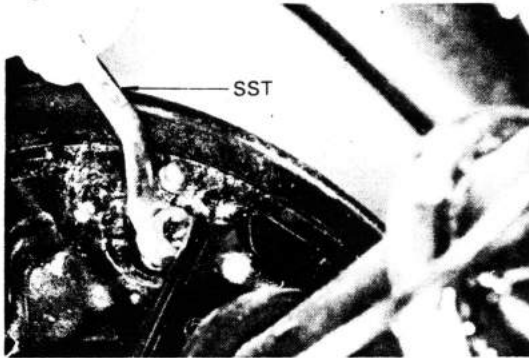

Disconnect the brake tube and remove the wheel cylinder with SST. SST (09751-36011)

—Note—

Do not remove the wheel cylinder unless necessary.

Fig. 9-255

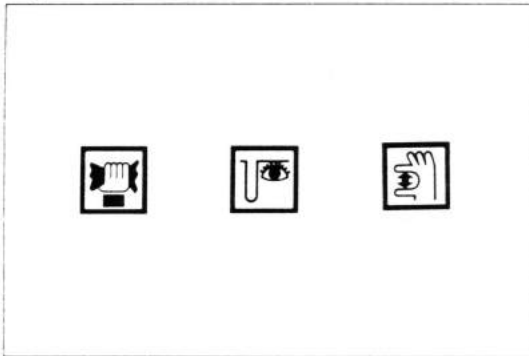

INSPECTION & REPAIR

Inspect the disassembled parts on the following points and repair or replace parts if necessary.

Fig. 9-256

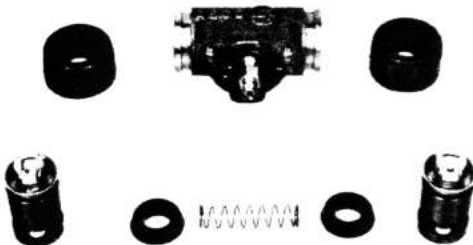

Wheel Cylinder

Inspect the wheel cylinder disassembled parts for wear, damage, crack or corrosion.

—Note—

1. **Clean the wheel cylinder components parts with brake fluid.**
2. **Do not reuse the piston cups and the boots.**

Fig. 9-257

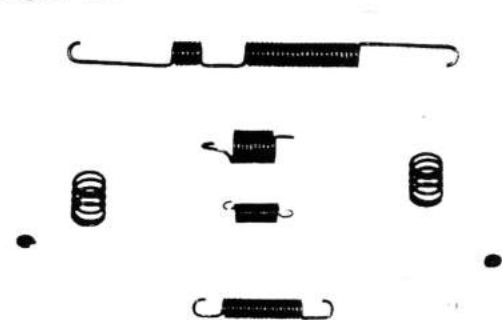

Spring

Inspect for damage or weakening.

Fig. 9-258

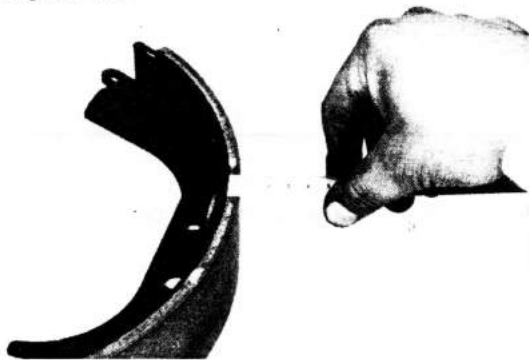
**Brake Shoe & Lining**

1. Inspect for wear, damage or deformation.

Lining thickness:

**Limit 1.5 mm
(0.059 in.)**

—Note—

When any lining requires replacement, it should be replaced as a set for both rear wheels to maintain effective brakes.

Fig. 9-259



2. Inspect the brake lining and drum for proper contact.

Fig. 9-260

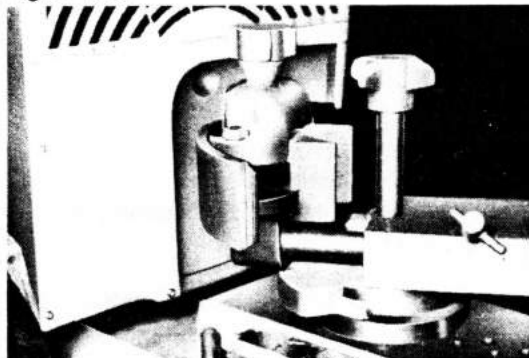

3. If the contact between the brake lining and drum is improper, repair the lining with a brake shoe grinder, or replace the brake shoe assembly.

Fig. 9-261

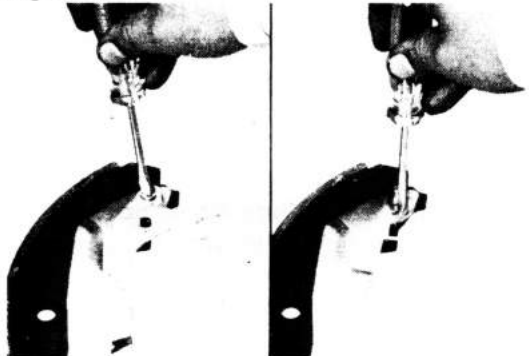
**Replace The Brake Shoe**

1. Remove the E ring and C washer

Fig. 9-262



2. Inspect for wear or damage.

Fig. 9-263

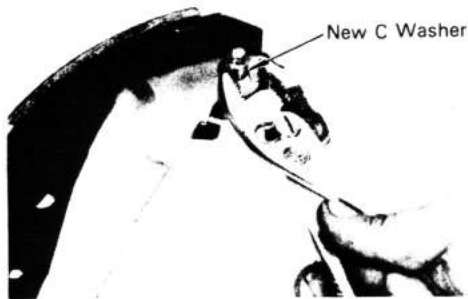

3. Stake a new C washer and E ring.

Fig. 9-264



4. Make sure that the lever moves smoothly.

Fig. 9-265



Parking Brake Shoe Strut Set
Inspect the strut set for wear or damage.

Fig. 9-266

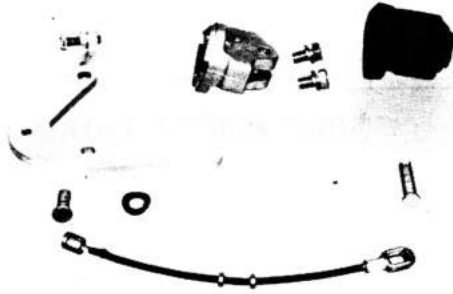
**Bell Crank**

1. Inspect the pins and other fasteners for wear or damage.
2. Inspect the boot for wear or damage.
3. Inspect the bell crank for bending or damage.

Fig. 9-267

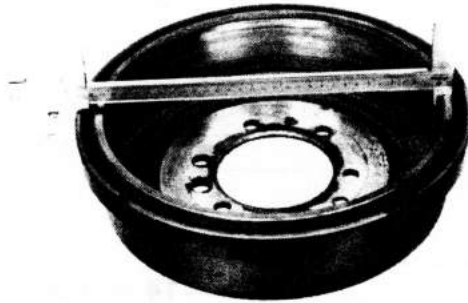
**Brake Drum**

1. Inspect the brake drum for wear, scoring or cracks.
2. Measure the brake drum inner diameter.

Drum inner diameter:

STD 295 mm
(11.61 in.)

Limit 297 mm
(11.69 in.)

Fig. 9-268

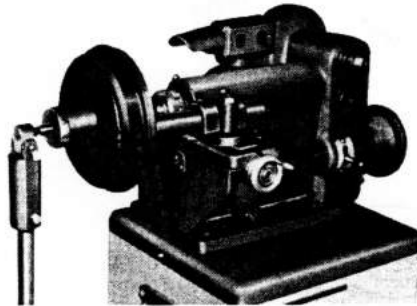

3. Using a drum lathe, rebore the brake drum if necessary.

Fig. 9-269

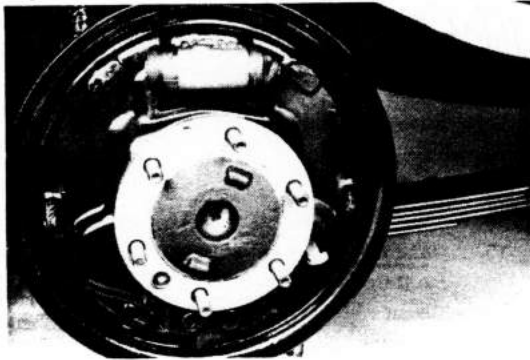
**Backing Plate**

Inspect for damage or weakening.

ASSEMBLY & INSTALLATION

Assemble and install the parts in the numerical order shown in the figure.

Fig. 9-270

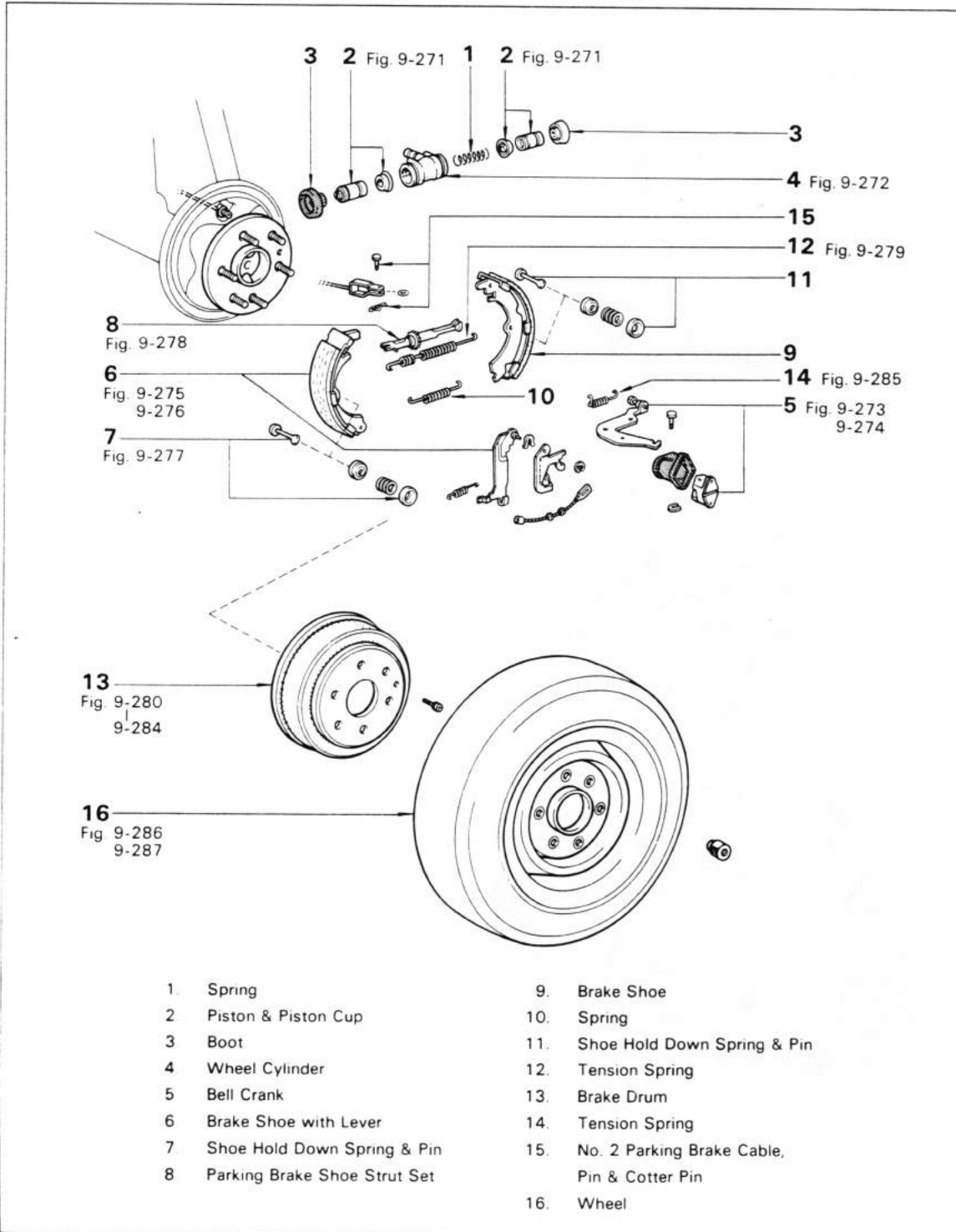
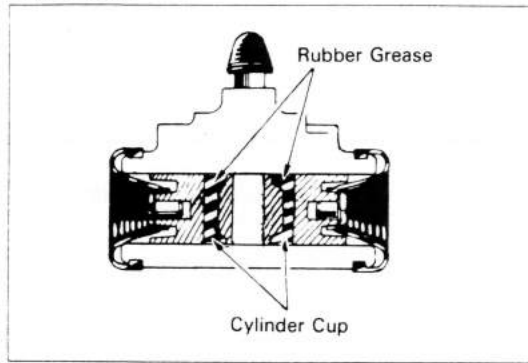
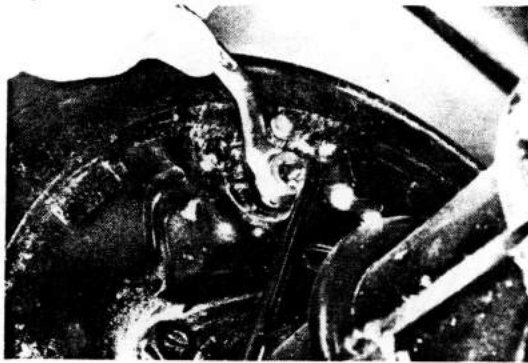

Fig. 9-271



Coat the cylinder cups with rubber grease. Be sure to install the cylinder cups in the correct direction.

Fig. 9-272



1. Install the wheel cylinder.
Tightening torque:
0.8 – 1.2 kg-m
(70 – 104 in.-lb)
2. Connect the brake tube with SST.
SST [09751-36011]
Tightening torque:
1.3 – 1.8 kg-m
(10 – 13 ft-lb)

Fig. 9-273

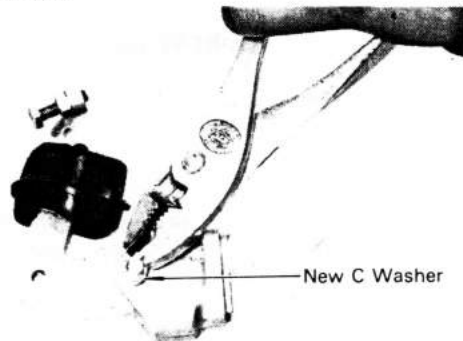

Install the bell crank to the bracket.

—Note—
A new C washer must be used.

Fig. 9-274

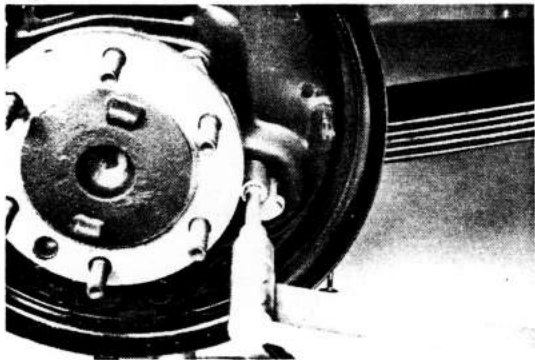

Tighten the bell crank bracket bolts.

Tightening torque: 1.0 – 1.6 kg-m
(7 – 11 ft-lb)

Install the parts as shown in the figure.

Fig. 9-275

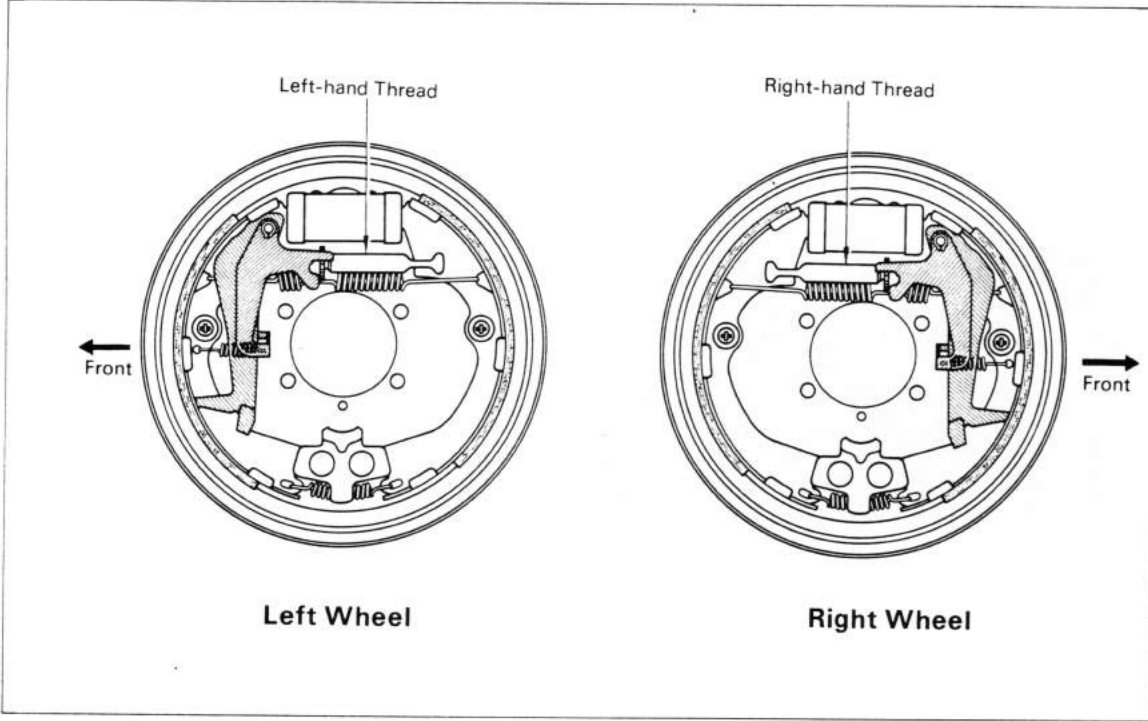
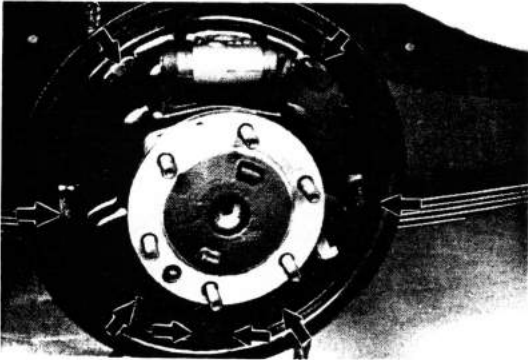

Fig. 9-276



Coat non-melt type grease on the backing plate at surfaces contacting the shoes.

Fig. 9-277



Install the shoe hold down spring with SST. SST [09718-00010]

Fig. 9-278

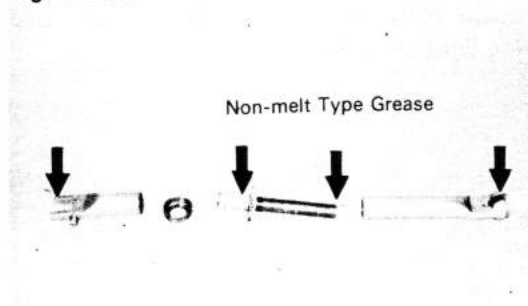

Coat on non-melt type grease to the adjuster bolt threads and insertion end.

Fig. 9-279



Install the spring to the shoe with SST. SST [09703-30010]

Fig. 9-280

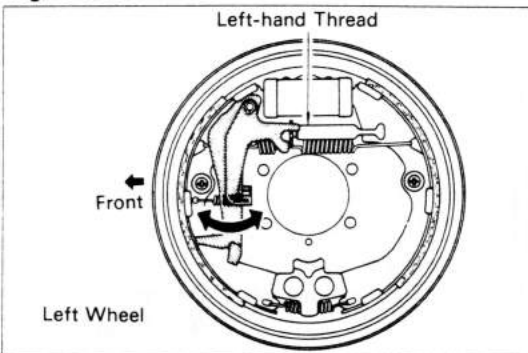

Check the operation of the automatic adjuster mechanism.

Fig. 9-281

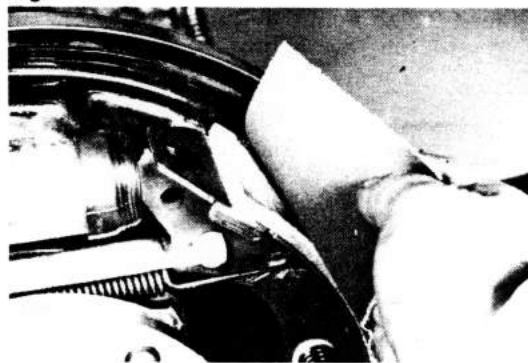

Polish the drum and shoe surfaces with sandpaper.

Fig. 9-282



Clean the inner drum with sandpaper, applying light pressure.

Fig. 9-283

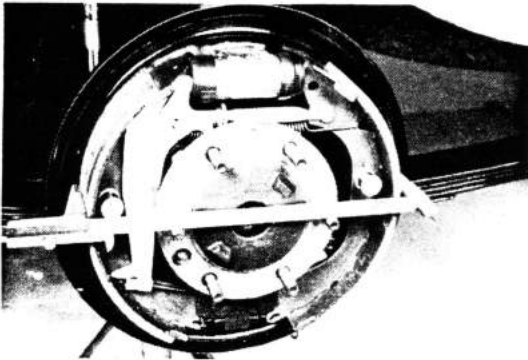

Before installing the drum, adjust the clearance between the shoes and drum.

1. Measure the shoes outer diameter.

Fig. 9-284

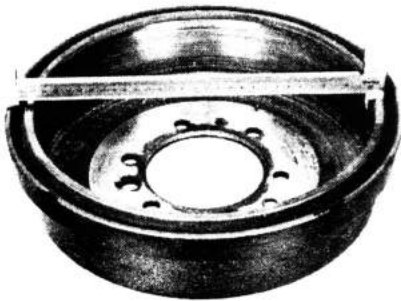

2. Measure the inner diameter of drum.
3. Adjust the clearance by turning the adjuster bolt.

**Shoe clearance: 0.6 mm
(0.024 in.)**

Fig. 9-285

SEE
AIR BLEEDING
SECTION
Fig. 9-11 to 9-14

Bleed the air from the system.

Fig. 9-286

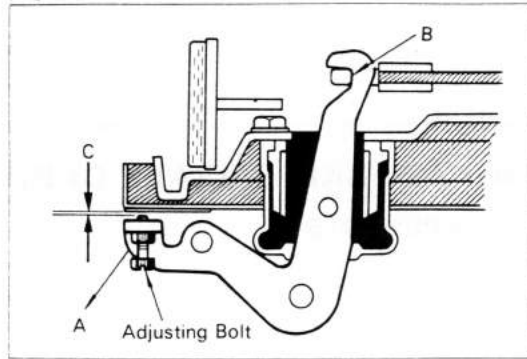

Adjust the bell crank.

1. Lightly pull the bell crank in direction A until there is no slack at part B. Under this condition, turn the adjusting bolt so that dimension C will be 0.4 – 0.8 mm (0.016 – 0.031 in.)
2. After adjustment, lock the adjusting bolt with the lock nut.

Tightening torque:

**0.4 – 0.7 kg-m
(35 – 60 in.-lb)**

Fig. 9-287

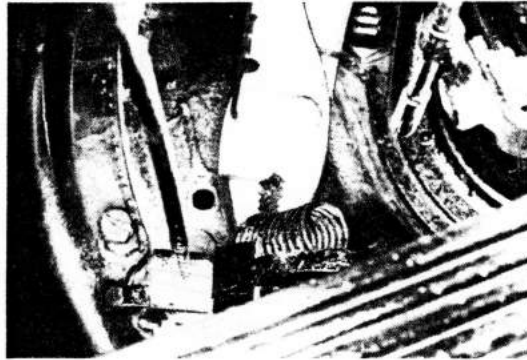

3. Install the tension spring.

PARKING BRAKE PARKING BRAKE LEVER COMPONENTS

Fig. 9-288

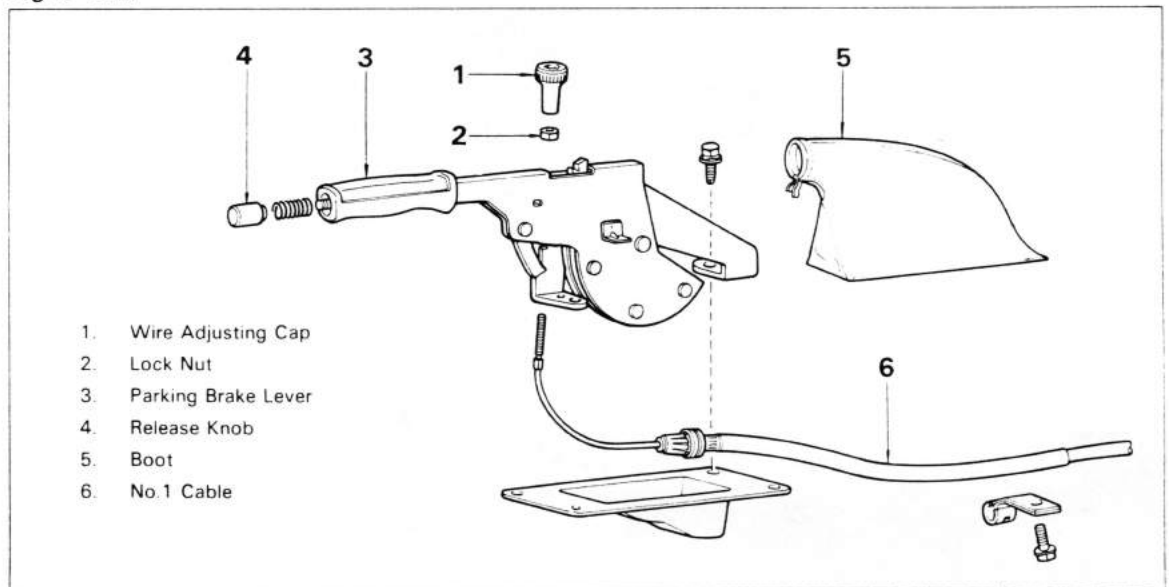

1. Wire Adjusting Cap
2. Lock Nut
3. Parking Brake Lever
4. Release Knob
5. Boot
6. No.1 Cable

NO. 2 PARKING BRAKE CABLE COMPONENTS

Fig. 9-289

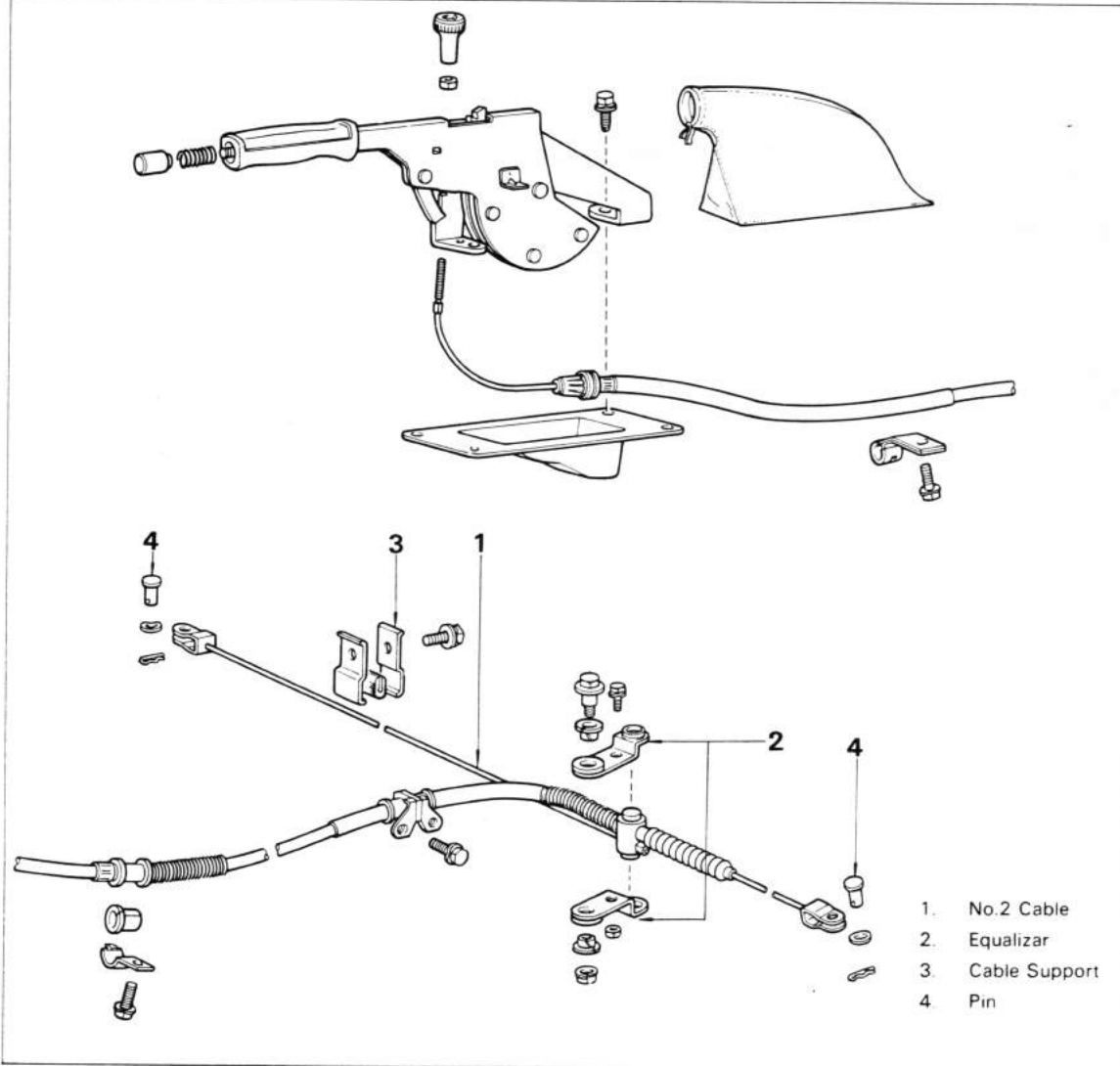
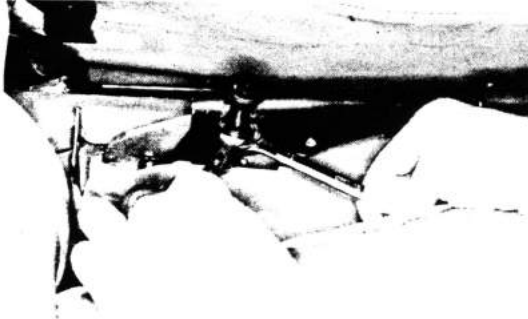

Fig. 9-290



REMOVAL

If the wire adjusting cap is tight and difficult to get loose, loosen in the manner shown in the figure.

Fig. 9-291

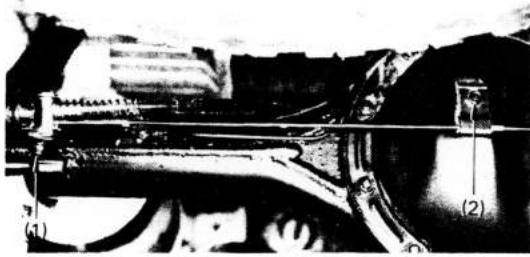

Remove the equalizer (1) and support lever (2).

Fig. 9-292

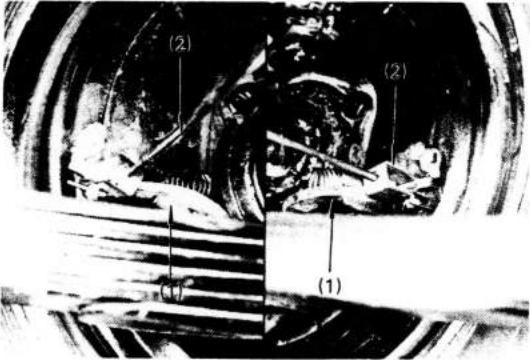

Disconnect the bell crank (1) and parking brake cable No. 2 (2).

Fig. 9-293

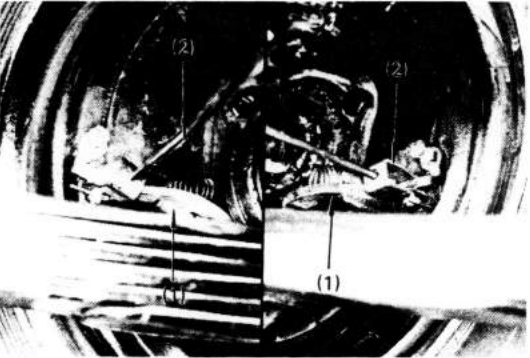

INSTALLATION

1. Connect the bell crank (1) and parking brake cable No. 2 (2).

Fig. 9-294

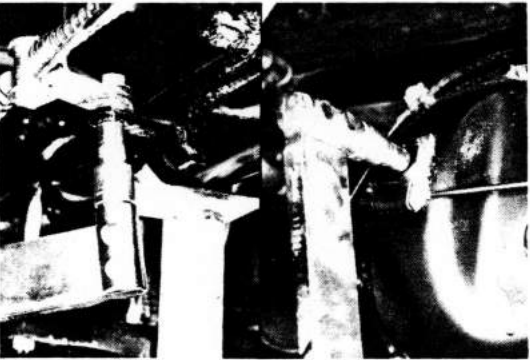

2. Install the equalizer and support lever.

Fig. 9-295

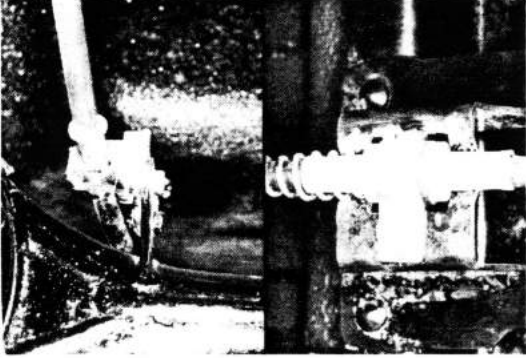

3. Install the cable bracket and clip.

Fig. 9-296

**SEE
PARKING BRAKE
ADJUSTMENT
SECTION
Fig. 9-8 to 9-10**

4. Adjust the parking brake control handle travel after installation.

CENTER BRAKE COMPONENTS

Fig. 2-297

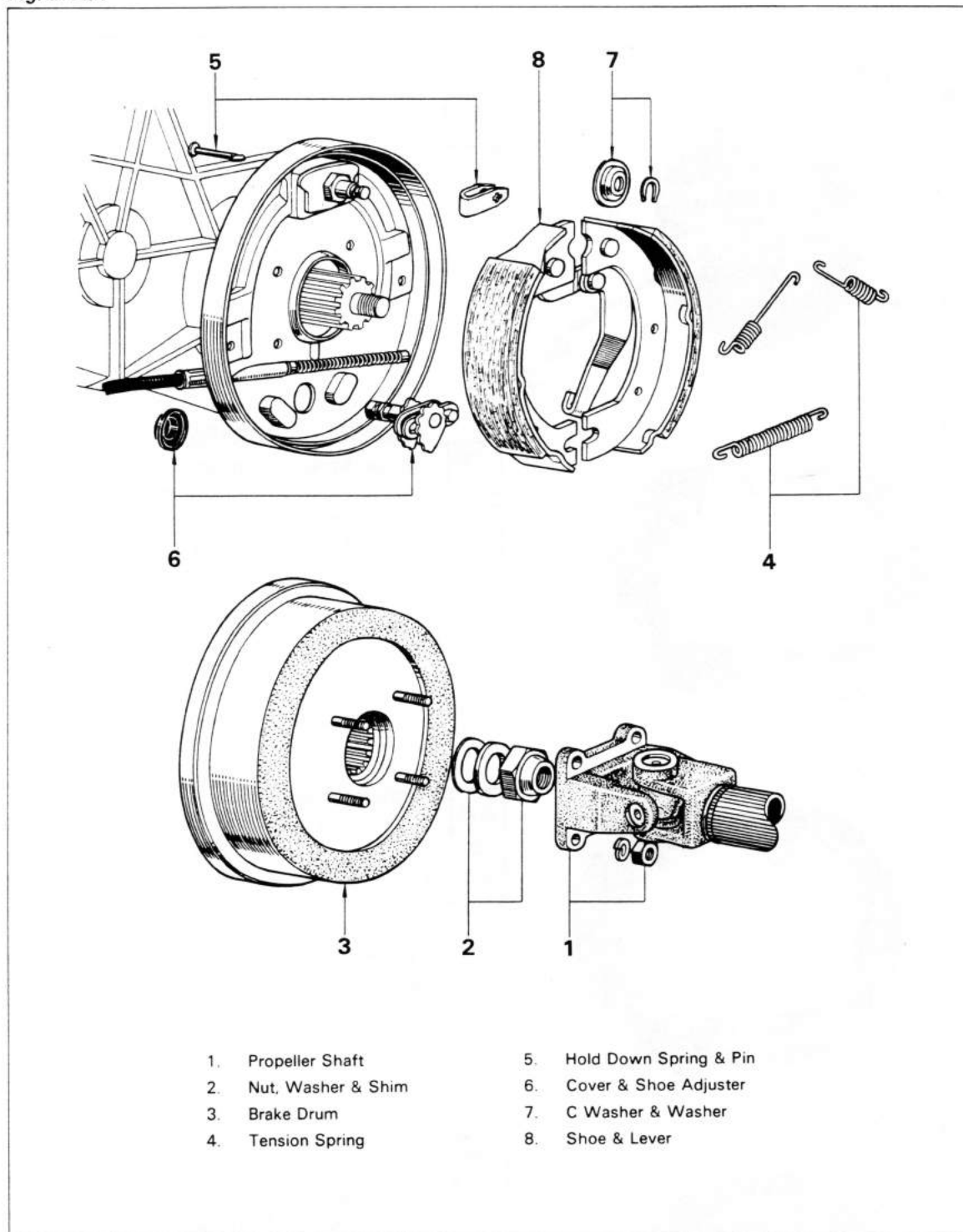

- | | |
|-----------------------|---------------------------|
| 1. Propeller Shaft | 5. Hold Down Spring & Pin |
| 2. Nut, Washer & Shim | 6. Cover & Shoe Adjuster |
| 3. Brake Drum | 7. C Washer & Washer |
| 4. Tension Spring | 8. Shoe & Lever |

Fig. 9-298

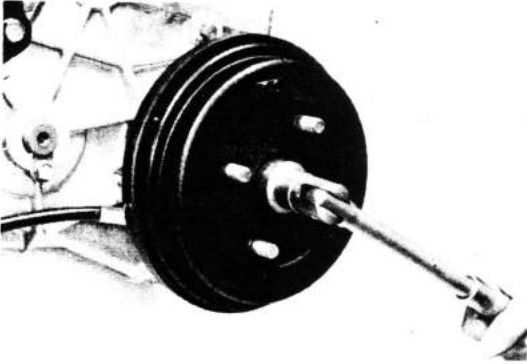

1. With the vehicle in front drive, engage the parking brake and foot brake.
2. Remove the nut after unlocking its staked parts.

Fig. 9-299

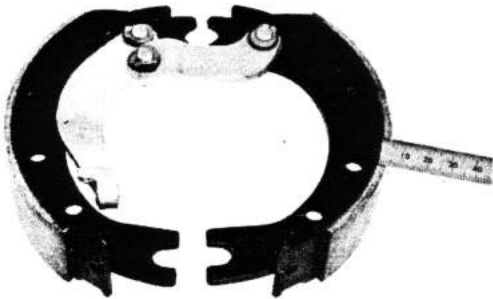
**INSPECTION & REPAIR****Brake Shoe & Lining**

Inspect for wear, damage or deformation.

**Lining thickness:**

Limit 1.5 mm
(0.059 in.)

Fig. 9-300

**Replace The Shoe**

1. Remove the C washers and replace the shoe.
2. Coat non-melt type grease on the pins, and install the shoe assembly.

—Note—

Illustration shows LHD vehicle.

Fig. 9-301

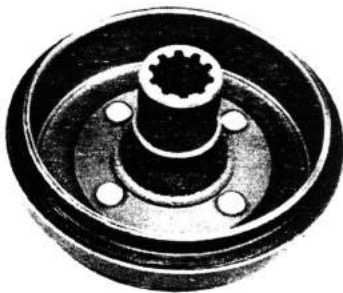
**Brake Drum**

Inspect the inner surface for wear or damage.

Drum inner diameter:

Limit 161 mm
(6.34 in.)

Fig. 9-302

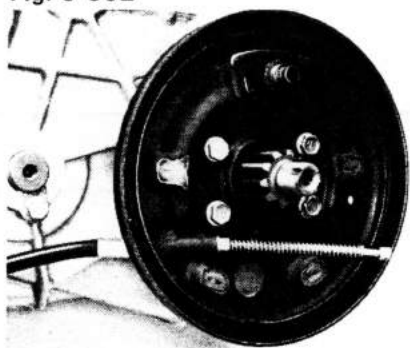
**Backing Plate & Parking Brake Cable**

1. Inspect the backing plate for wear or cracks.
2. Inspect the parking brake cable for damage and its sliding condition.

Fig. 9-303

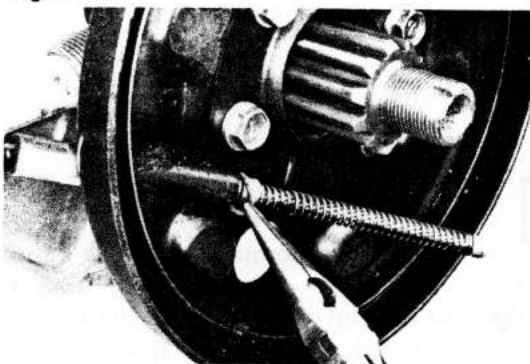
**Replace The Parking Brake Cable**

1. At the backing plate, remove and reinstall the C washer.
2. At the parking brake lever, refer to the procedures described in Transmission Removal and Installation.

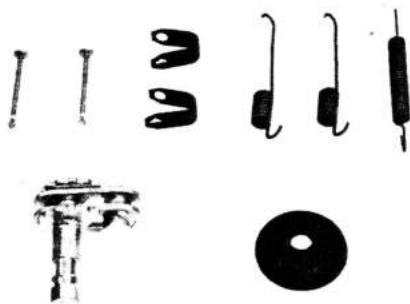
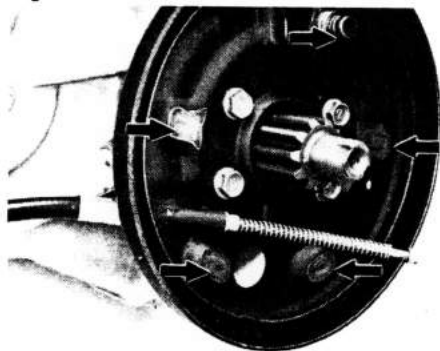

Fig. 9-304

**Adjuster, Spring & Pin**

Inspect for wear or damage.

Fig. 9-305



Apply non-melt type grease to the place indicated by arrow.

Fig. 9-306

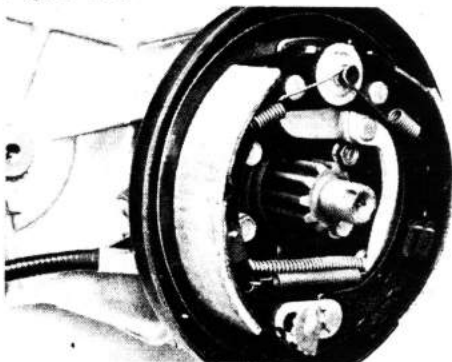

Install the lower side tension spring from the inner side.

Fig. 9-307

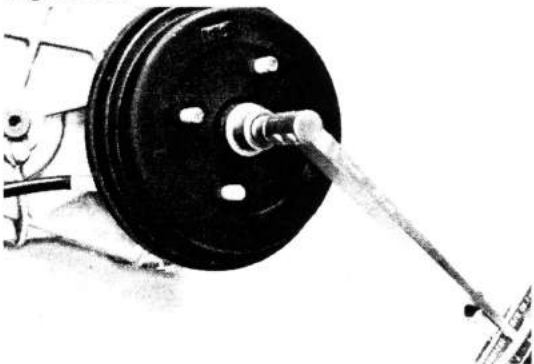

Tighten the nut at the specified torque, and stake the nut to prevent loosening.

**Tightening torque: 14 – 17 kg-m
(102 – 122 ft-lb)**

Adjust the parking brake after installation by methods described under Adjustment.

P & B VALVE (PROPORTIONING & BYPASS VALVE)

INSPECTION

Inspect on the following points.

1. Brake fluid leakage
2. Hydraulic pressure

Using two pressure gauges, measure the hydraulic pressures in the master cylinder and rear wheel cylinder. If they conform to the values shown in the diagrams below, the condition is good.

—Note—

1. Do not attempt to disassemble or adjust the P and B valve.
2. If the P valve is found to be defective, replace the entire P and B valve assembly.

Fig. 9-308

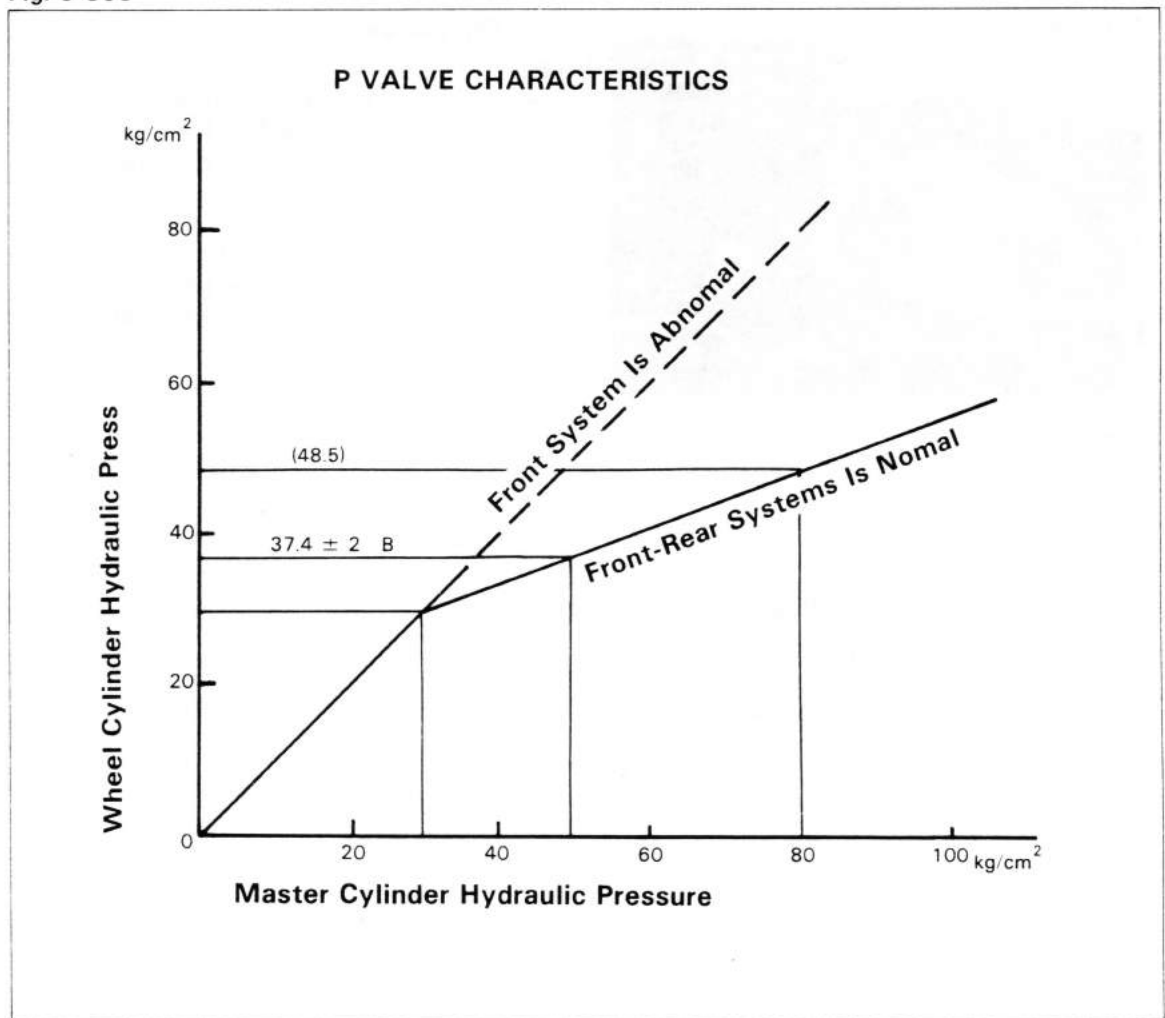

Fig. 9-309

**REMOVAL**

Remove the following parts.

1. Brake pipe
SST [09751-36011]
2. Bolt
3. P & B valve

Fig. 9-310

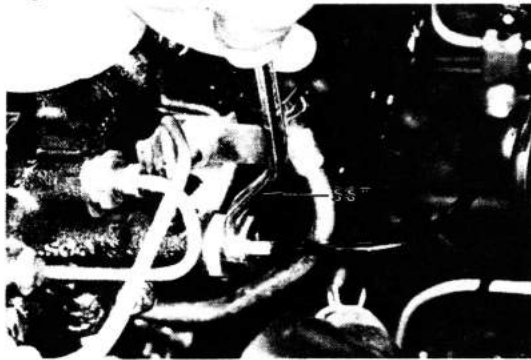
**INSTALLATION**

1. Install the P and B valve
Tightening torque:
0.4 – 1.0 kg-m
(35 – 86 in.-lb)
2. Connect the brake pipes with SST.
SST [09751-36011]
Tightening torque:
1.3 – 1.8 kg-m
(10 – 13 ft-lb)

Fig. 9-311

SEE
AIR BLEEDING
SECTION
Fig. 9-11 to 9-14

3. Bleed the air from the system.

LSPV (LOAD SENSING PROPORTIONING VALVE) COMPONENTS

Fig. 9-312

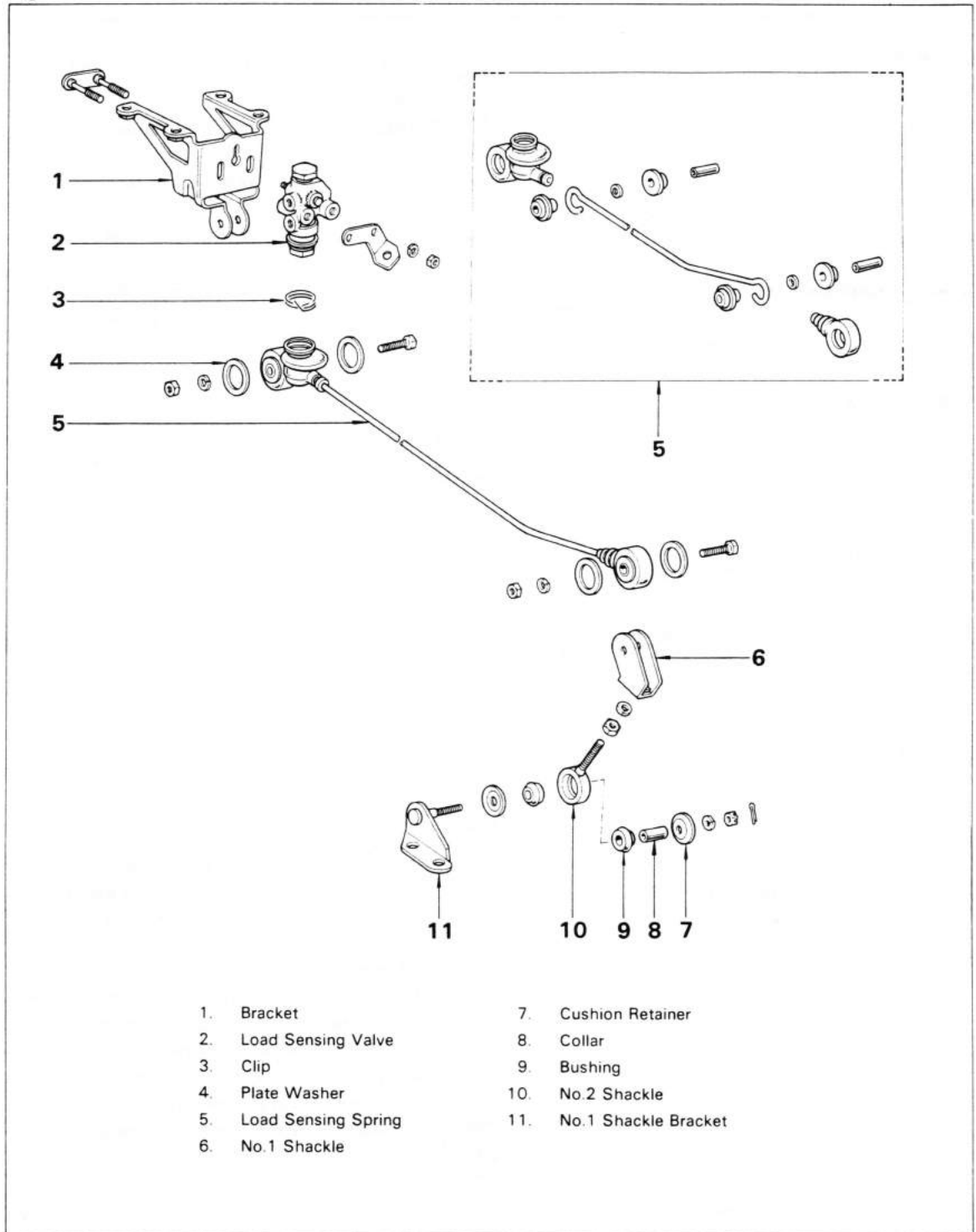
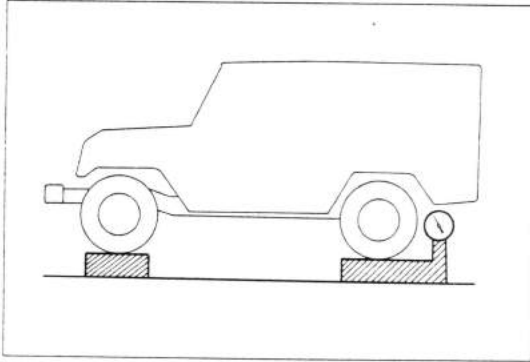

Fig. 9-313

**FLUID PRESSURE INSPECTION & REPAIR****Inspect The Fluid Pressure**

1. Set the rear axle load.

Rear axial load (include vehicle weight):

**6_series 1,200 kg
(2,646 lb)**

**4_series 1,150 kg
(2,535 lb)**

Fig. 9-314

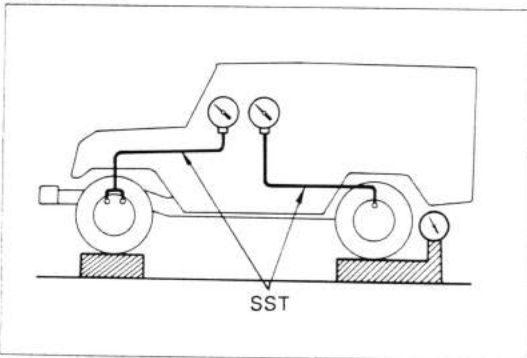

2. Install the LSPV gauge (SST) and bleed the air.

SST [09709-29017]

Fig. 9-315

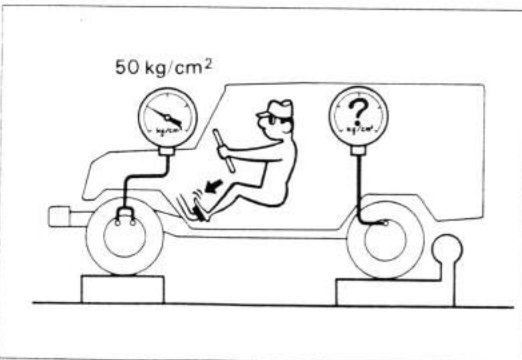

3. Raise the front brake pressure to 50 kg/cm² (711 psi) and check the rear brake pressure.

Rear brake pressure:

**40 ± 5 kg/cm²
(569 ± 71 psi)**

—Note—

1. Brake pedal should not be depressed twice and/or returned while setting to the specified fluid pressure.
2. Read the value of the rear wheel cylinder pressure two seconds after adjusting the specified fluid pressure.

Fig. 9-316

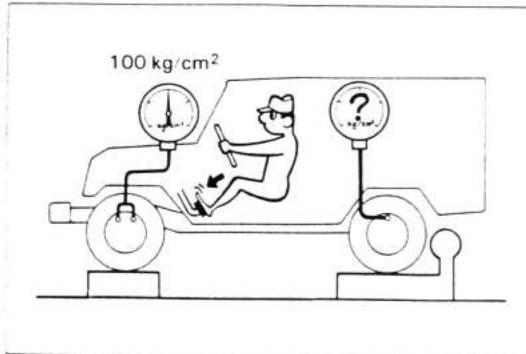

4. Raise the front brake pressure to 100 kg/cm² (1,422 psi) and check the rear brake pressure.

Rear brake pressure:

**58 ± 7 kg/cm²
(825 ± 100 psi)**

Fig. 9-317

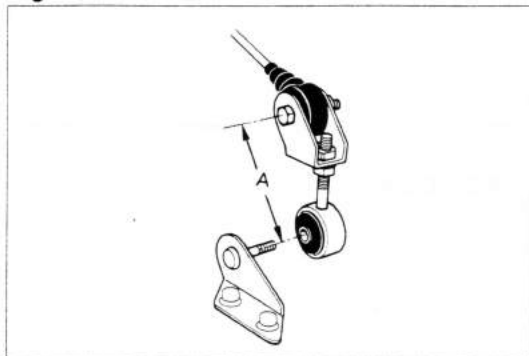

Fig. 9-318

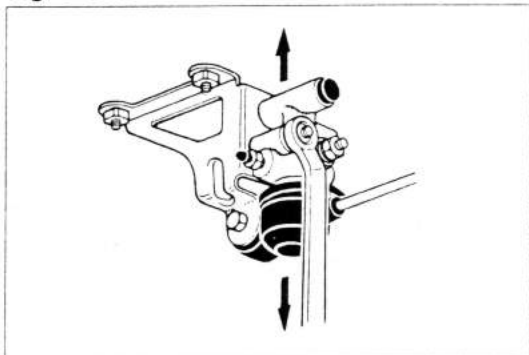

Fig. 9-319

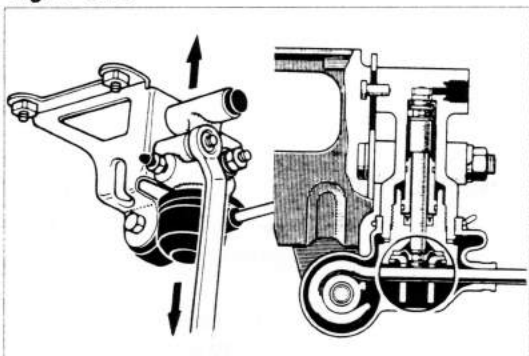
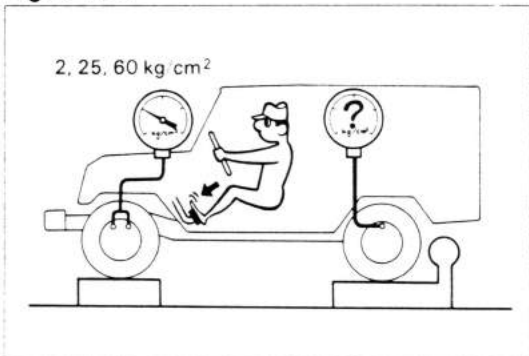

Fig. 9-320



Adjust The Fluid Pressure

- Adjust the length of the No. 2 shackle.
 Low pressure — Lengthen A
 High pressure — Shorten A

Model	Initial set	Adjusting range
FJ,BJ,HJ6_series	78 mm (3.07 in.)	72 – 84 mm (2.83 – 3.31 in.)
FJ40	90 mm (3.54 in.)	84 – 93 mm (3.31 – 3.66 in.)
FJ,BJ,HJ4_series except FJ40	120 mm (4.72 in.)	114 – 126 mm (4.49 – 4.96 in.)



–Note–

One turn of the No. 2 shackle changes the fluid pressure about 0.6 kg/cm² (8.5 psi).

- In event pressure cannot be adjusted by the No. 2 shackle, raise or lower the position of the valve body.

Low pressure — Lower

High pressure — Raise

Tightening torque:

**1.0 – 1.6 kg-m
(8 – 11 ft-lb)**



- Adjust the length of the No. 2 shackle again.

Inspect The Load Sensing Valve

If it cannot be adjusted, inspect the valve housing in the following manner.

- Assemble the valve body in the uppermost position.

–Note–

When the brakes are applied, the piston will move down about 1 mm (0.04 in.). Even at this time, the piston should not contact or move the load sensing spring.



- In this position, check the rear wheel cylinder pressure.

kg/cm² (psi)

Front wheel	Rear wheel
5 (71)	5 (71)
25 (356)	10.4 – 14.4 (148 – 205)
60 (835)	21.9 – 28.9 (312 – 411)

- If the measured value is not within standard, replace LSPV assembly.

cardiagn.com

Fig. 9-321

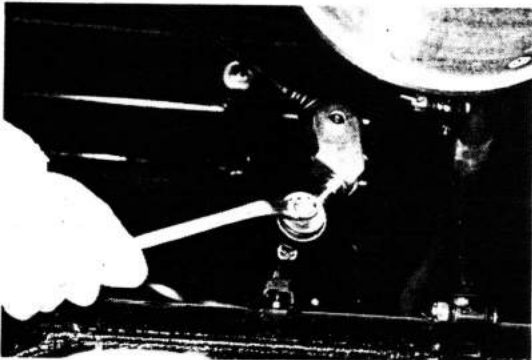
**REMOVAL**

1. Disconnect the No. 2 shackle from the bracket.

Fig. 9-322

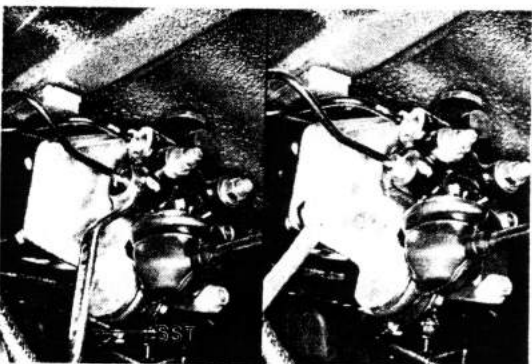

2. Disconnect the brake tube unions with SST.
SST [09751-36011]
3. Remove the load sensing valve bracket.

Fig. 9-323

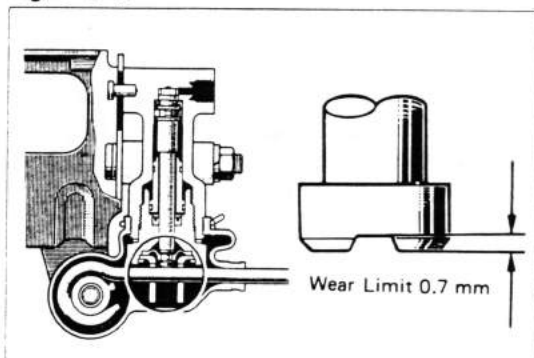
**INSPECTION**

1. Inspect the valve piston pin and load sensing spring contact surfaces for wear.

Wear:

Limit 0.7 mm
(0.028 in.)

Fig. 9-324

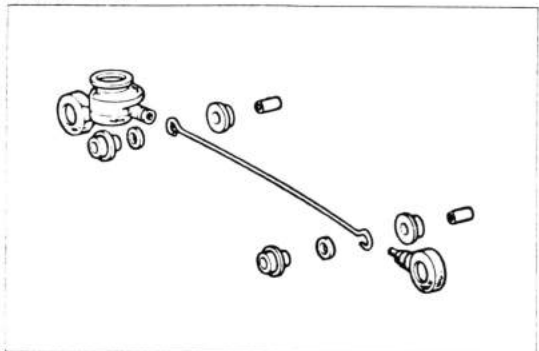

2. Inspect the load sensing spring, shackle bracket, etc. for any noticeable rust or damage.

Fig. 9-325

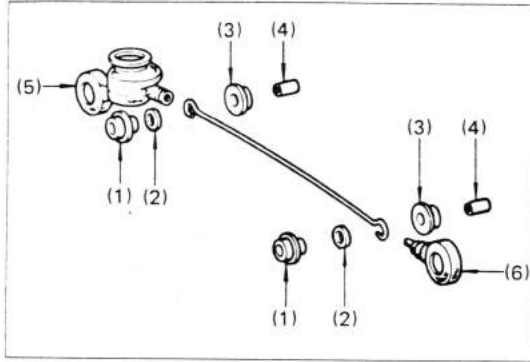
**INSTALLATION**

1. Assemble the following parts to the load sensing spring.
 - (1) Bushing
 - (2) Rubber plate
 - (3) Bushing
 - (4) Collar
 - (5) Load sensing valve boot
 - (6) Load sensing spring boot

Fig. 9-326

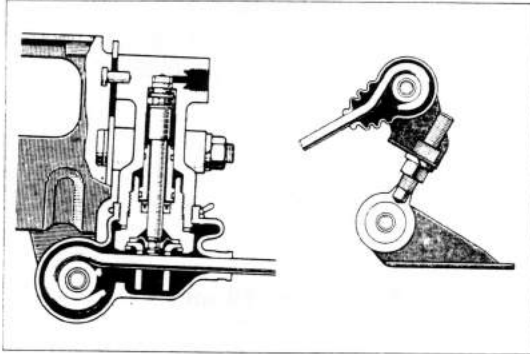
**-Note-**

1. Do not mistake the valve side for the shackle side of the load sensing spring.
2. Apply rubber grease to all rubbing areas.

Fig. 9-327



2. Assemble the LSPV to the bracket.

-Note-

Fingertighten the LSPV mounting bolts.

Fig. 9-328

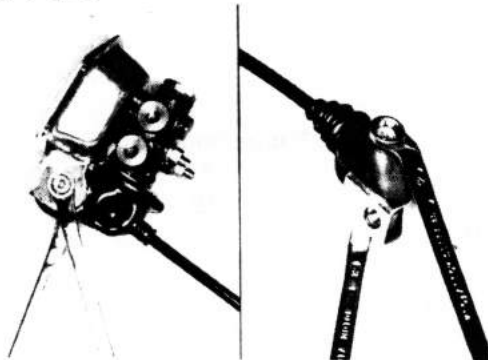

3. Connect the LSPV and No. 1 shackle to the load sensing spring.

Tightening torque:

1.5 – 2.2 kg-m
(11 – 15 ft-lb)

Fig. 9-329

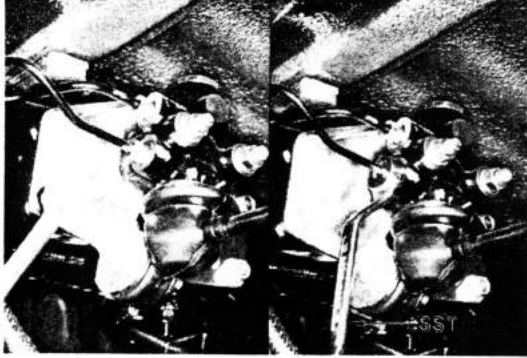

4. Install the LSPV to the frame.

Tightening torque:

**1.5 – 2.2 kg-m
(11 – 15 ft-lb)**

5. Connect the brake tube to the LSPV with SST.

SST [09751-36011]

Tightening torque:

**1.3 – 1.8 kg-m
(10 – 13 ft-lb)**

Fig. 9-330

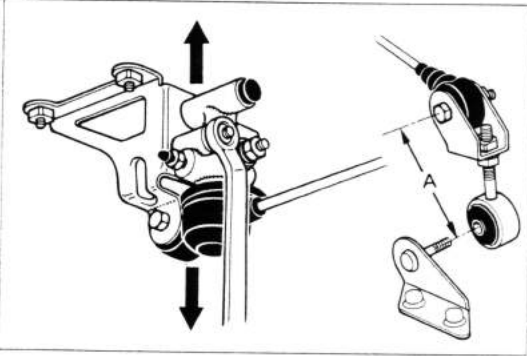

6. Assemble the No. 2 shackle to the No. 1 shackle and set the length of the No. 2 shackle.

Initial set: 78 mm

(3.07 in.)

7. Connect the No. 2 shackle to the bracket.
8. Bleed the brake line. (Refer to AIR BLEEDING See Fig. 9-11 to 9-14).

Fig. 9-331

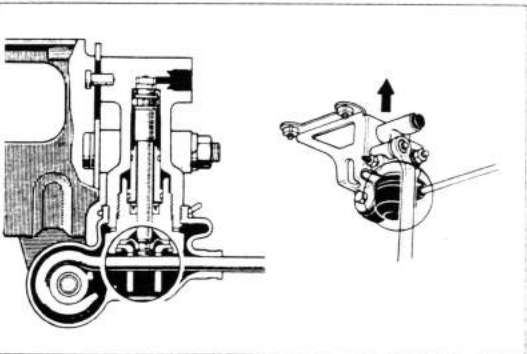

9. Set the LSPV body in the following procedure.

- (1) Set the rear axle load.
- (2) When pulling down the load sensing spring, confirm that the valve piston moves down smoothly.
- (3) Position the valve body so that the valve piston lightly contacts load sensing spring
- (4) Tighten the valve body mounting nuts.

Tightening torque:

1.0 – 1.6 kg-m

(8 – 11 ft-lb)

Fig. 9-332

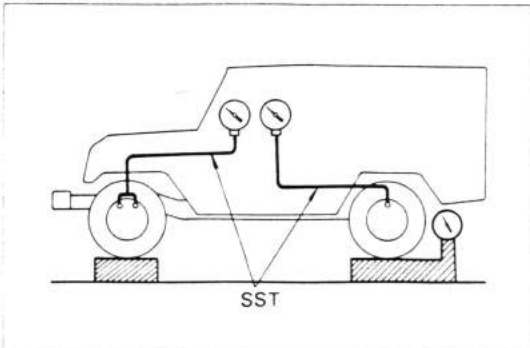

10. Install the LSPV gauge (SST) and bleed the air.
SST [09709-29017]

11. Inspect and adjust the LSPV fluid pressure