

BODY ELECTRICAL

	Page
WIRING COLOR CODE & BULKHEAD TYPE CONNECTOR HANDLING & INSPECTION	13-2
SWITCHES & RELAYS LOCATION	13-3
LIGHT COMPONENTS	13-10
RELAY BLOCK	13-13
FUSIBLE LINK	13-14
FUSE BLOCK	13-15
IGNITION SWITCH	13-18
COMBINATION SWITCH	13-23
LIGHTING	13-33
TURN SIGNAL & HAZARD WARNING LIGHT	13-38
FRONT WIPER & WASHER	13-44
REAR WIPER & WASHER	13-55
HEADLIGHT CLEANER	13-61
SPEEDOMETER & COMBINATION METER	13-64
BRAKE WARNING SYSTEM	13-77
REAR WINDOW DEFOGGER	13-81
SEAT BELT WARNING	13-83
HEATER	13-85
RADIO & STEREO TAPE PLAYER	13-111

WIRING COLOR CODE & BULKHEAD TYPE CONNECTOR HANDLING & INSPECTION

1. WIRING COLOR CODE

Wire colors are indicated by an alphabetical code.

The 1st letter indicates the basic wire color and the 2nd indicates the stripe color.

B = Black	Br = Brown	G = Green
Gr = Grey	L = Light Blue	Lg = Light Green
O = Orange	P = Pink	R = Red
W = White	Y = Yellow	

Example: RG indicates a Red wire with a Green line.

2. BULKHEAD TYPE CONNECTOR HANDLING & INSPECTION

To remove the connector, push the lock levers shown in Fig. 13-1 and pull out.

When checking the continuity or voltage with a circuit tester, insertion of the test probe into the receptacle connector may open the fitting to the connector and result in poor contact. Therefore, insert the test probe only from the wire harness side as shown in Fig. 13-2.

Fig. 13-1

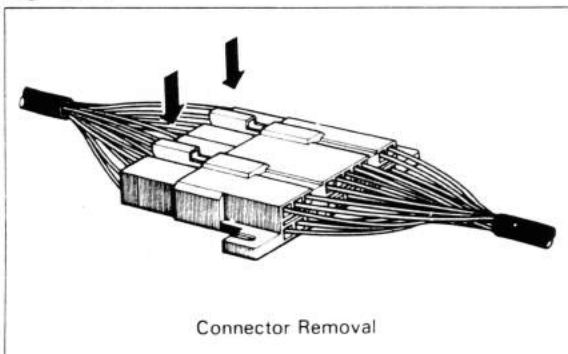

Fig 13-2

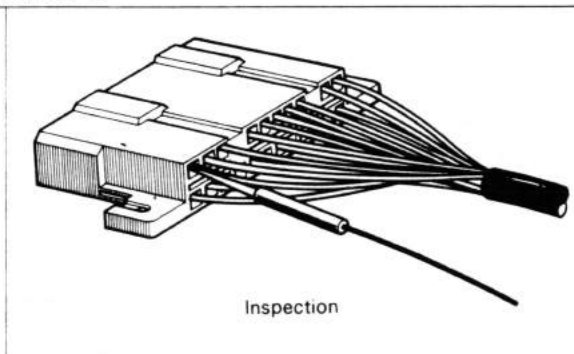

Fig. 13-3

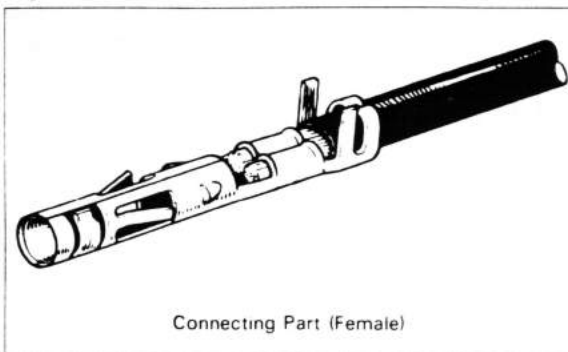
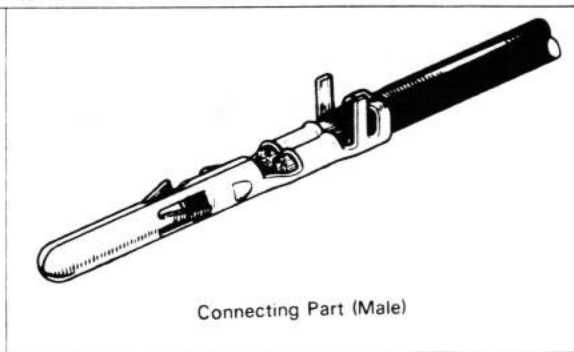

Fig 13-4



SWITCHES & RELAYS LOCATION

Fig. 13-5

FJ Series

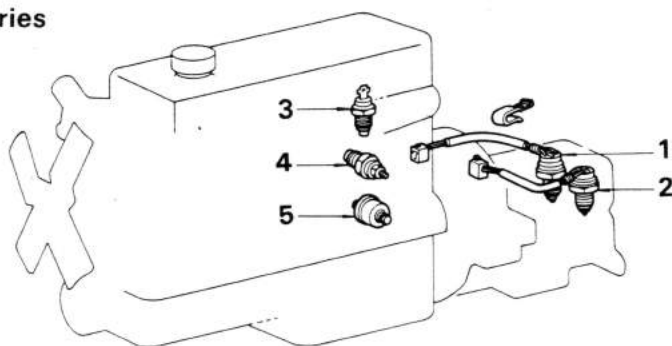

BJ Series

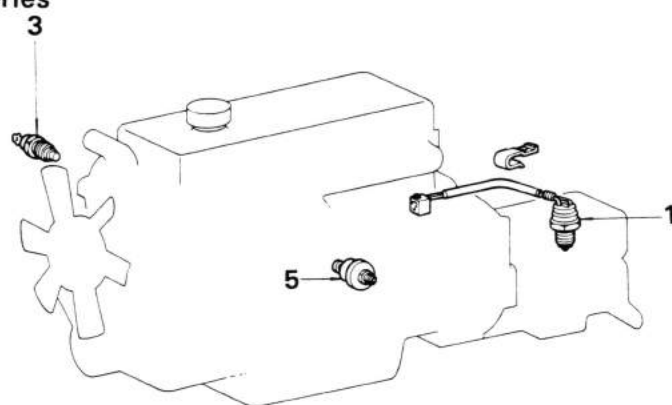

HJ Series

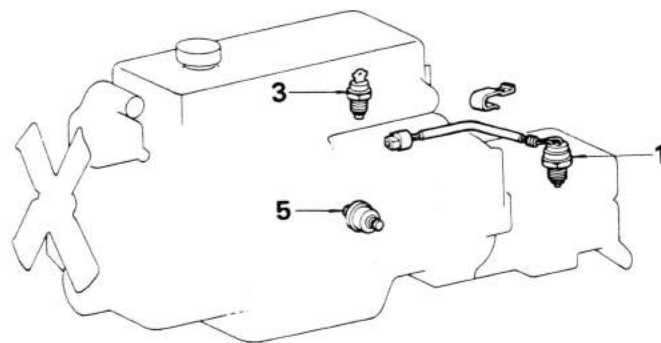

- 1. Back-up Light Switch
- 2. Shift Point Sensor
- 3. Water Temperature Sender Gauge

- 4. Manifold Temperature Sensor
- 5. Oil Pressure Sender Gauge

Fig. 13-6

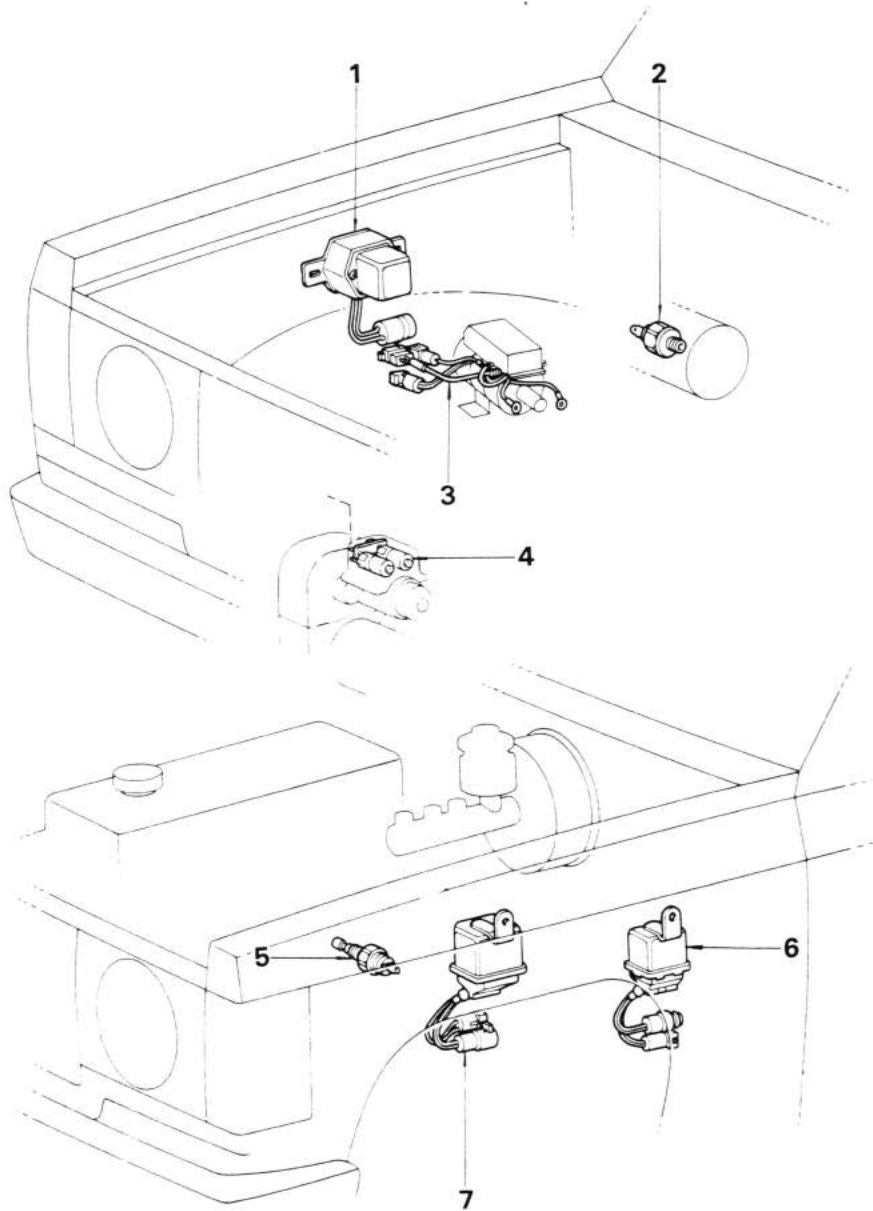

- 1 Generator Regulator
- 2 Vacuum Warning Switch
- 3 Igniter
- 4 Electric Winch Magnet Switch

- 5 Vacuum Switch
- 6 Glow Plug Relay
- 7 Stater Relay

Fig. 13-7

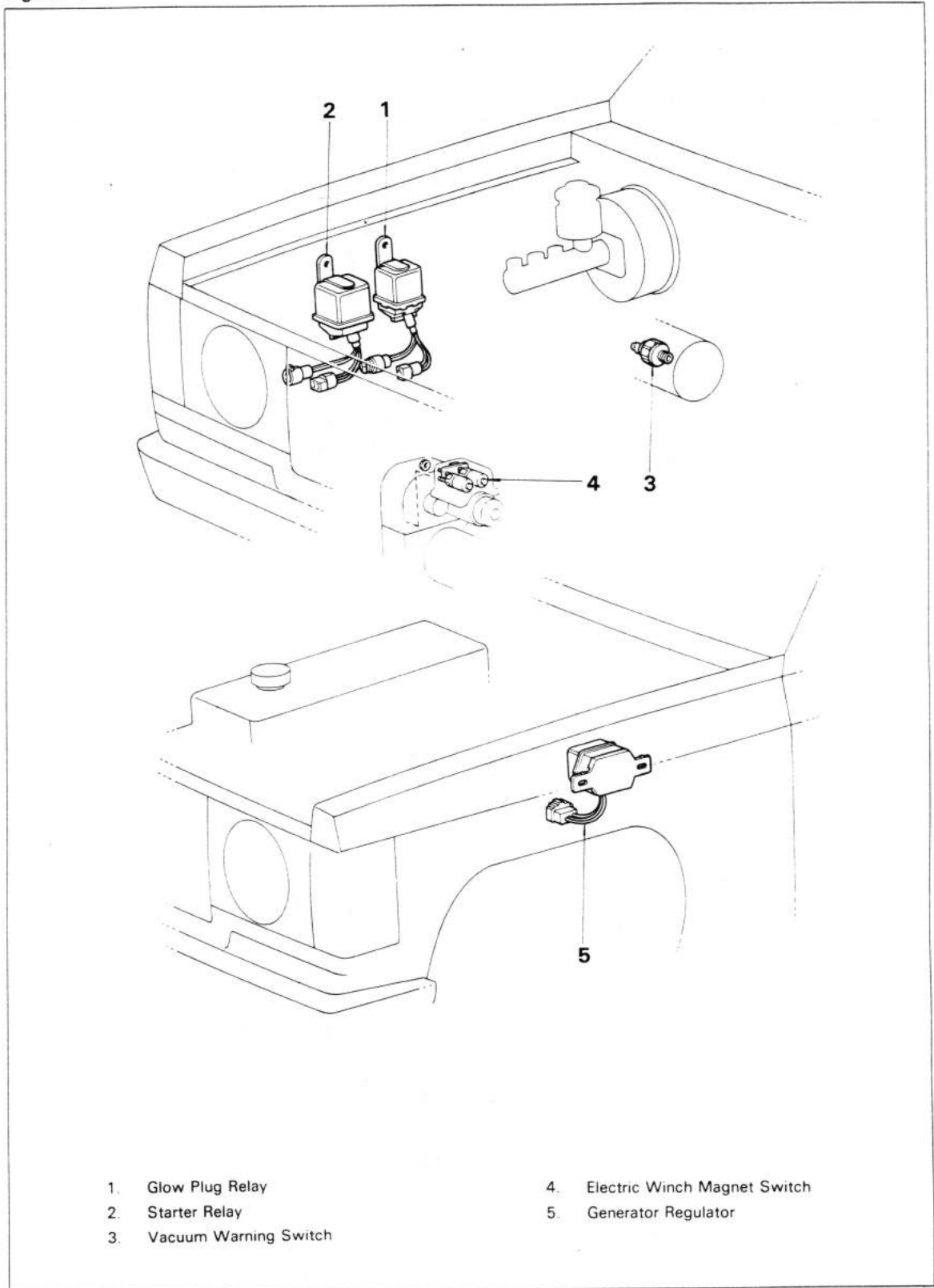

cardiagn.com

Fig. 13-8

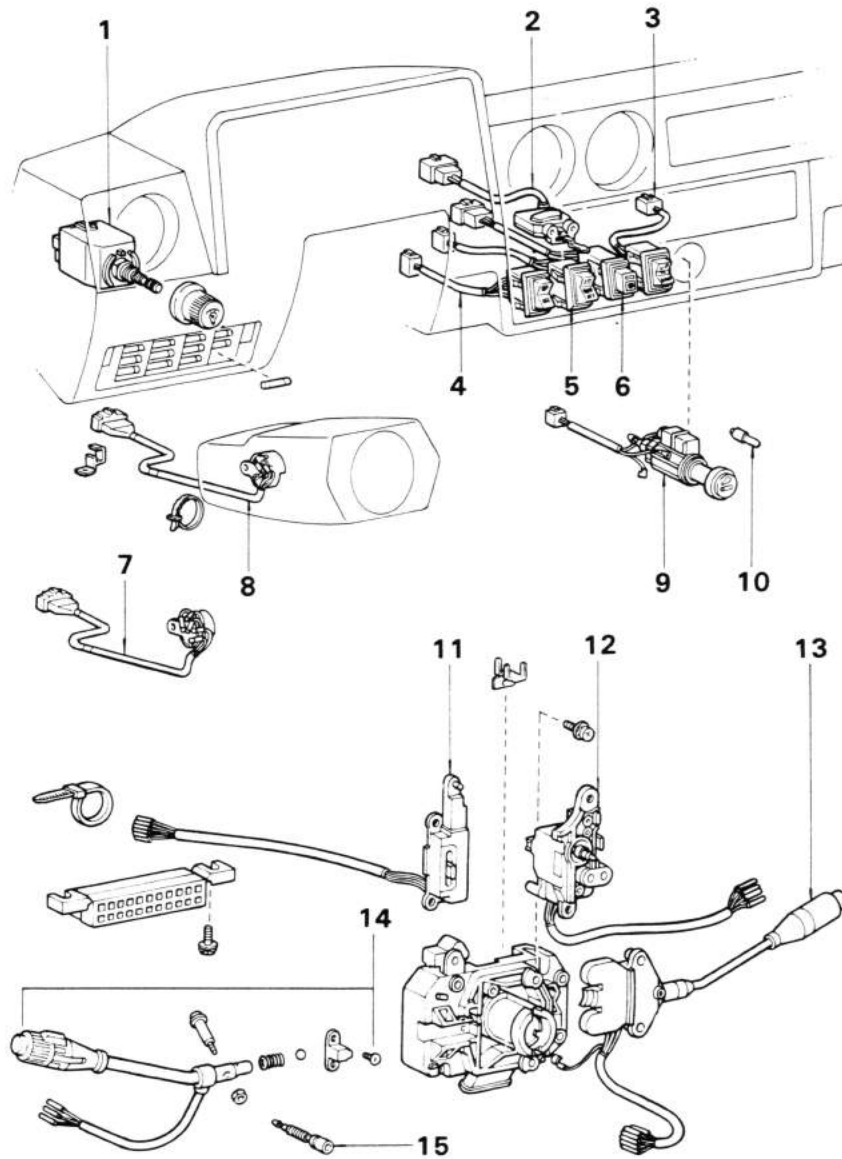

- 1 Light Control Rheostat
- 2 Front Heater Blower Switch
- 3 Antenna Switch
- 4 Windshield Wiper Switch
- 5 Rear Heater Blower Switch
- 6 Defogger Switch
- 7 Starter Switch
- 8 Ignition Switch

- 9 Cigarette Lighter
- 10 Cigarette Lighter Bulb
- 11 Hazard Warning Signal Switch
- 12 Headlight Dimmer Switch
- 13 Windshield Wiper Switch
- 14 Light Control Switch
- 15 Horn Contact Plate

Fig. 13-9

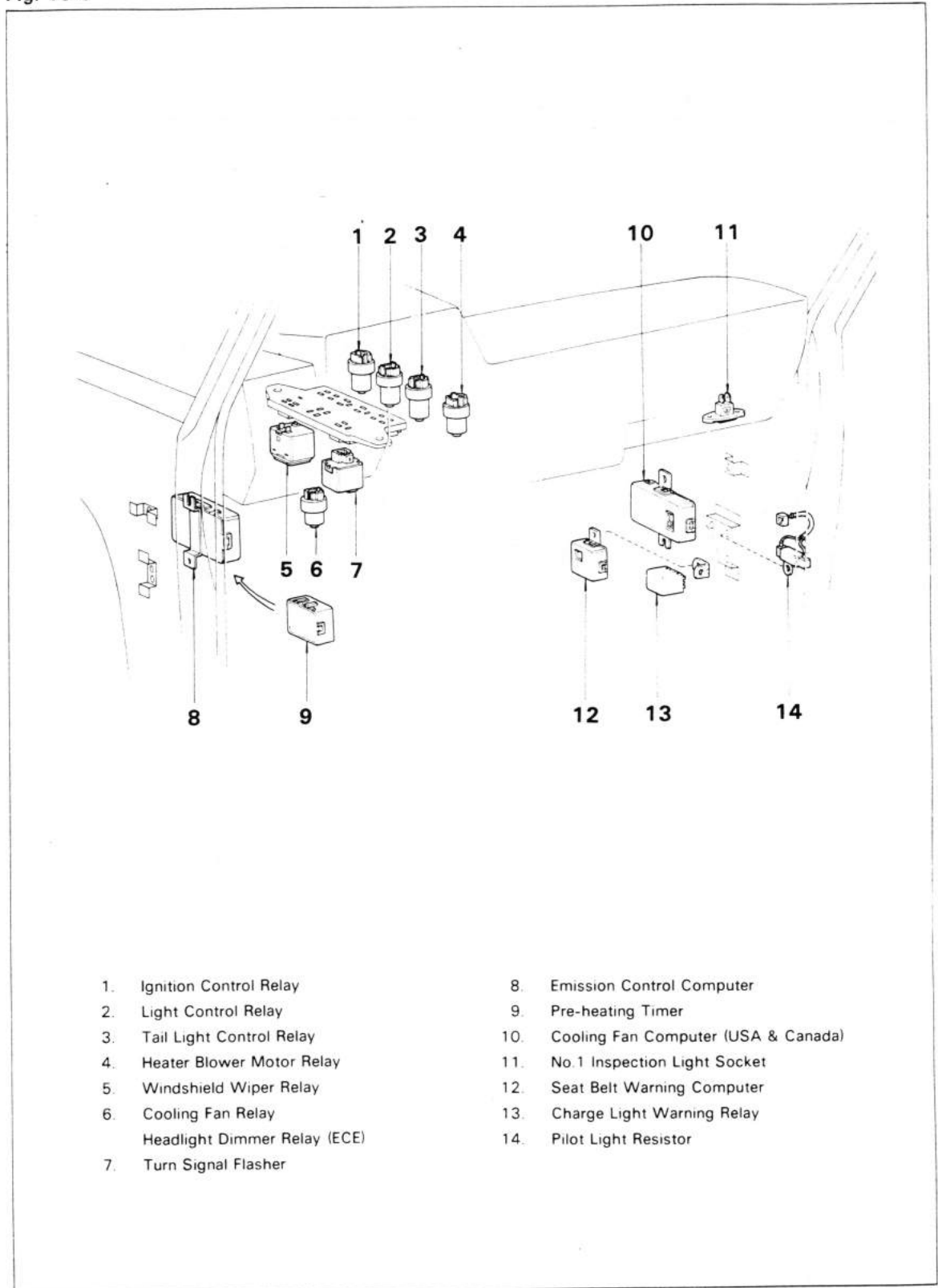

- | | |
|--|---|
| 1. Ignition Control Relay | 8. Emission Control Computer |
| 2. Light Control Relay | 9. Pre-heating Timer |
| 3. Tail Light Control Relay | 10. Cooling Fan Computer (USA & Canada) |
| 4. Heater Blower Motor Relay | 11. No.1 Inspection Light Socket |
| 5. Windshield Wiper Relay | 12. Seat Belt Warning Computer |
| 6. Cooling Fan Relay
Headlight Dimmer Relay (ECE) | 13. Charge Light Warning Relay |
| 7. Turn Signal Flasher | 14. Pilot Light Resistor |

Fig. 13-10

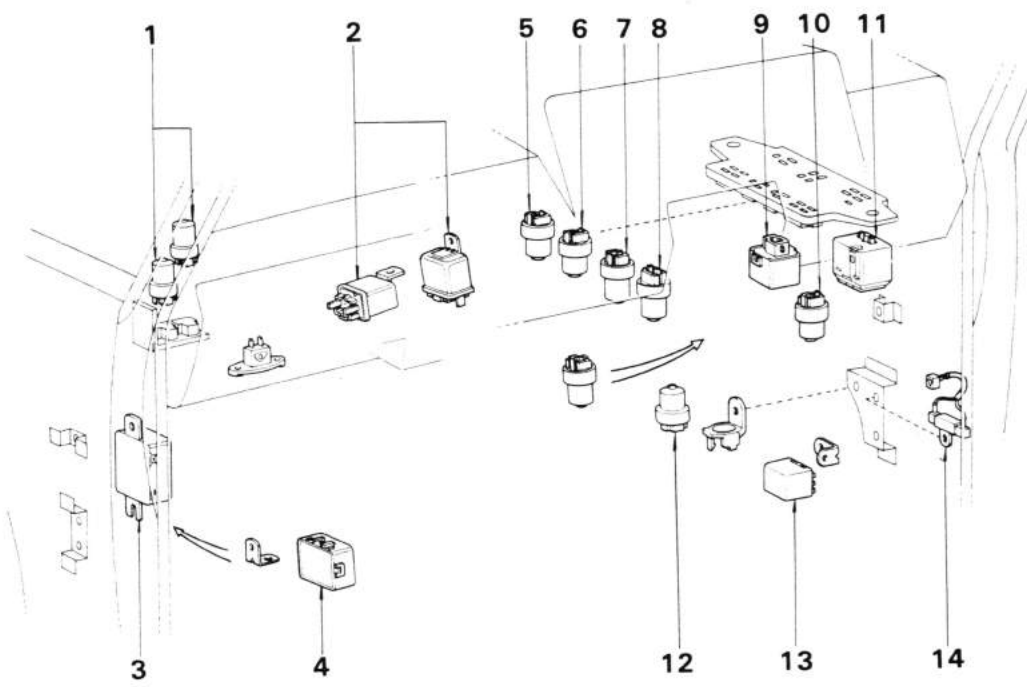

- 1. Turn Signal Cancelling Relay
- 2. Windshield Wiper Relay
- 3. Emission Control Computer
- 4. Pre-heating Timer
- 5. Heater Blower Motor Relay
- 6. Tail Light Control Relay
- 7. Light Control Relay

- 8. Ignition Control Relay
- 9. Turn Signal Flasher
- 10. Headlight Dimmer Relay (ECE)
Valve Check Relay (ARL)
- 11. Windshield Wiper Relay
- 12. Red Indicator Relay
- 13. Charge Light Warning Relay
- 14. Pilot Light Resistor

Fig. 13-11

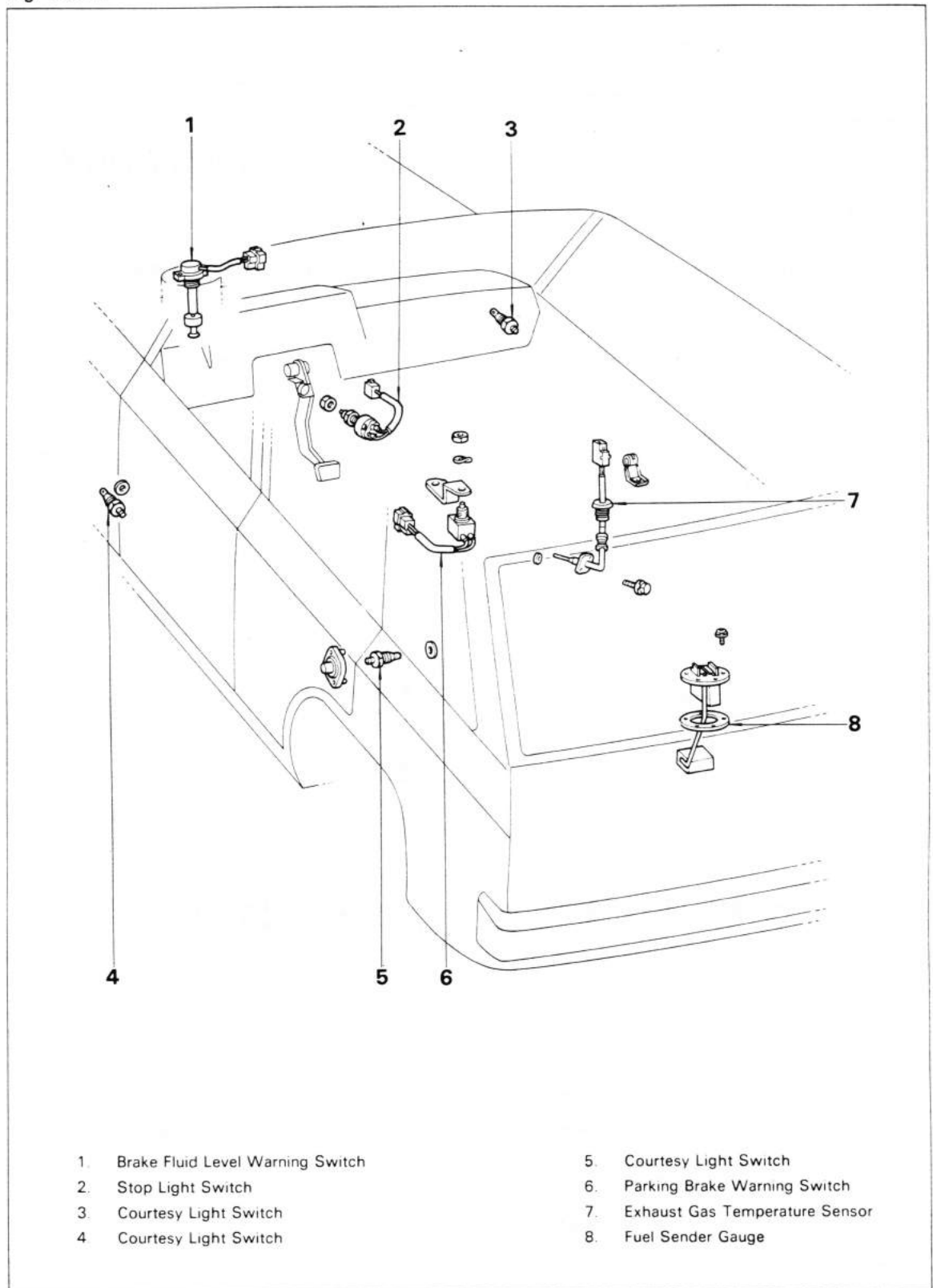

LIGHT COMPONENTS

Fig. 13-12

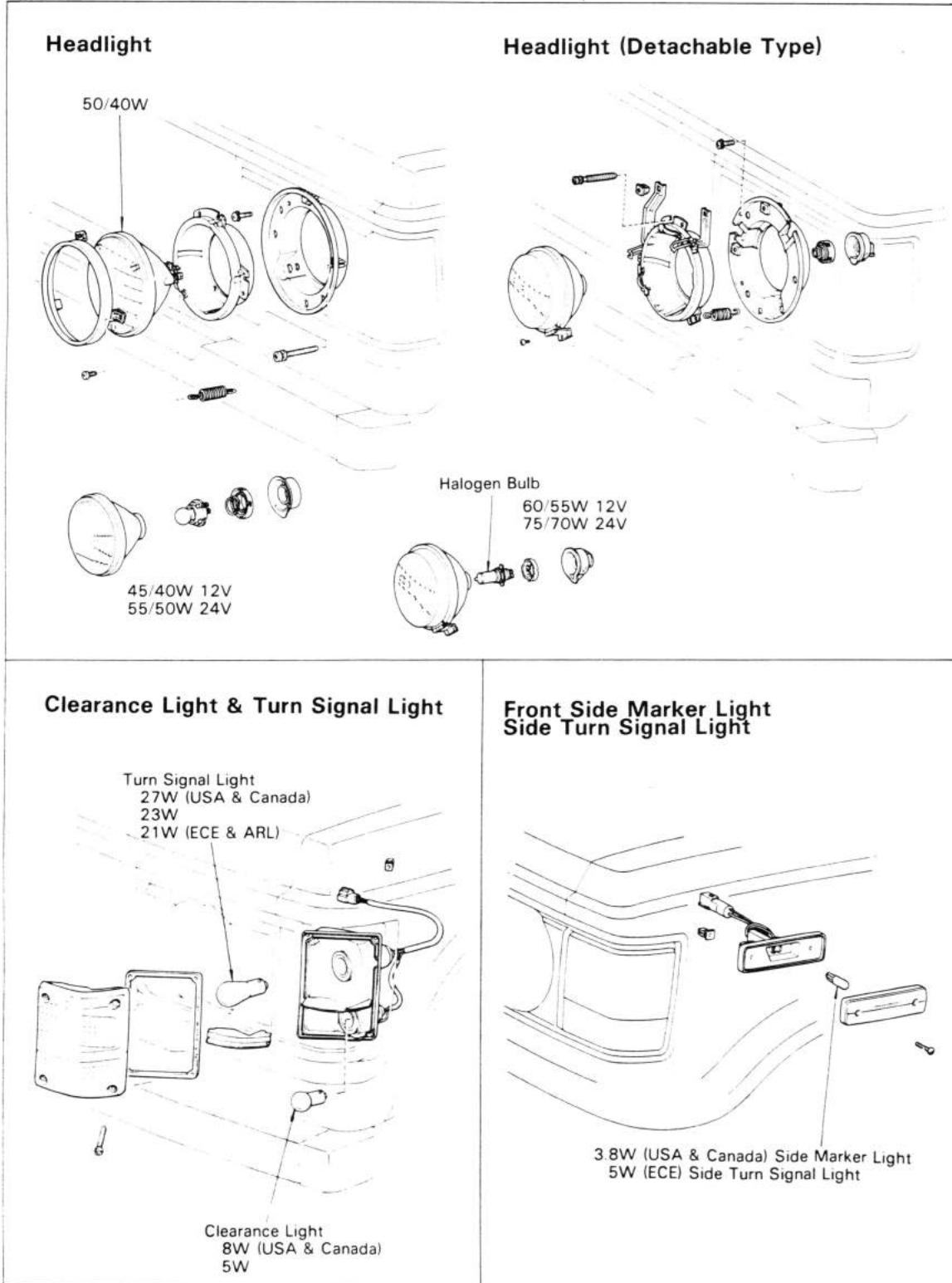
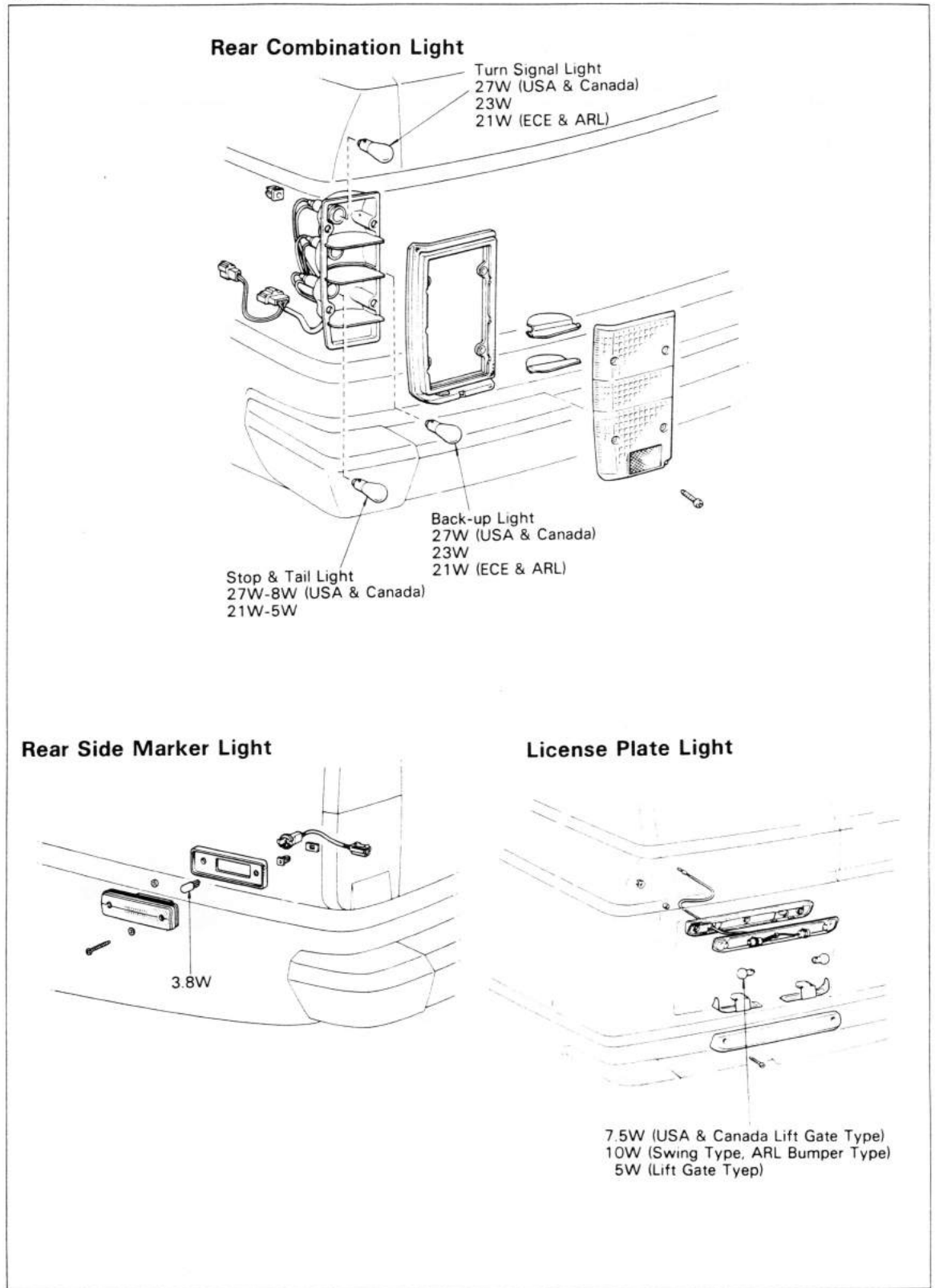
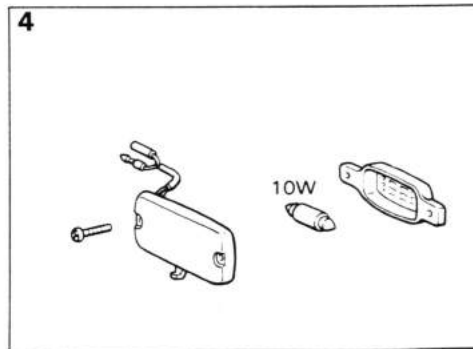
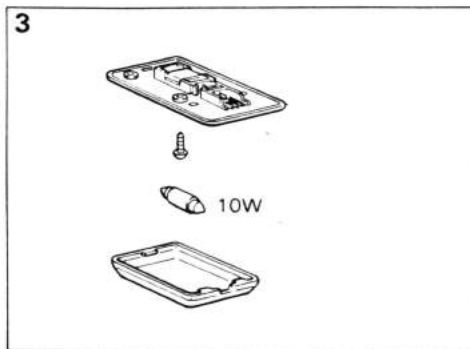
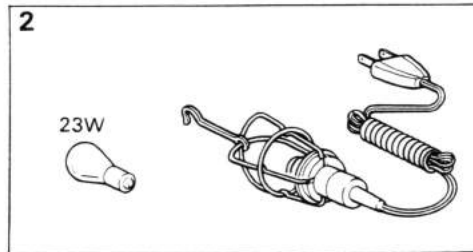
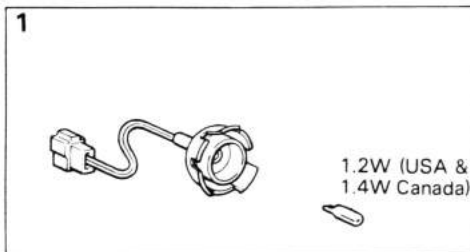
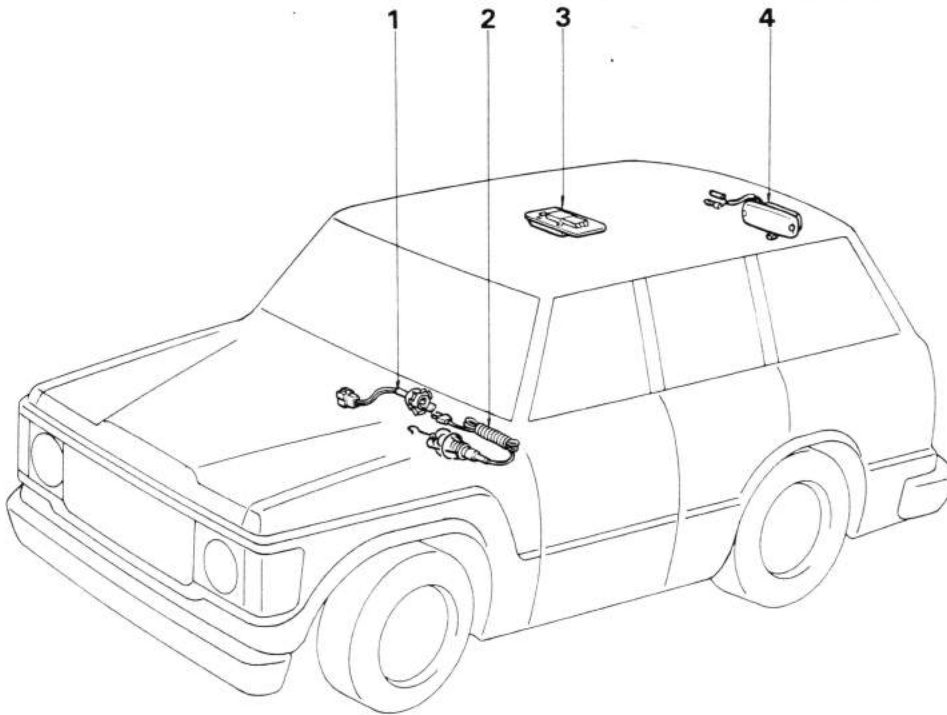

Fig. 13-13



cardiagn.com

Fig. 13-14



- 1. Glovebox Light
- 2. Inspection Light
- 3. Interior Light
- 4. Luggage Compartment Light

RELAY BLOCK

Fig. 13-15

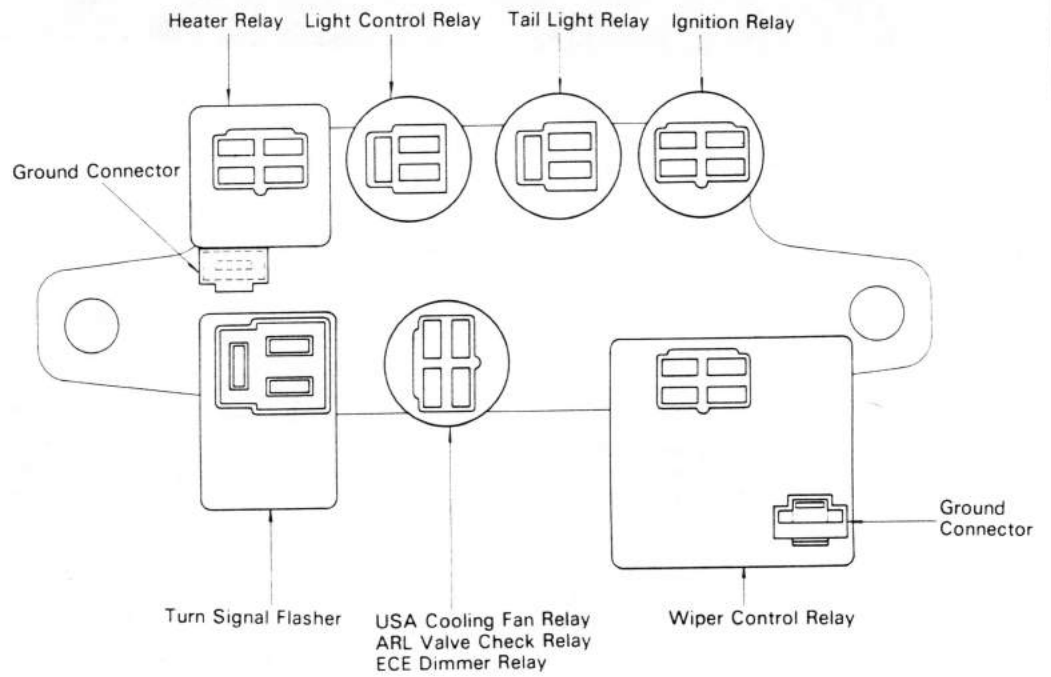
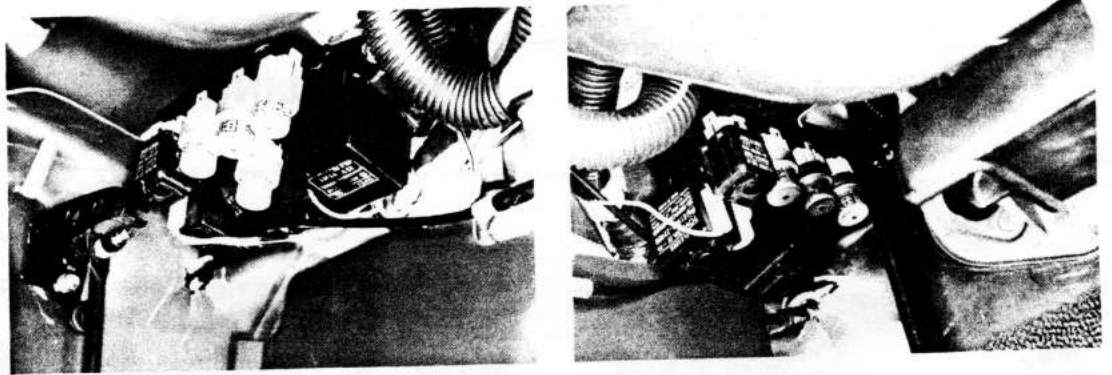

FUSIBLE LINK

Fig. 13-16

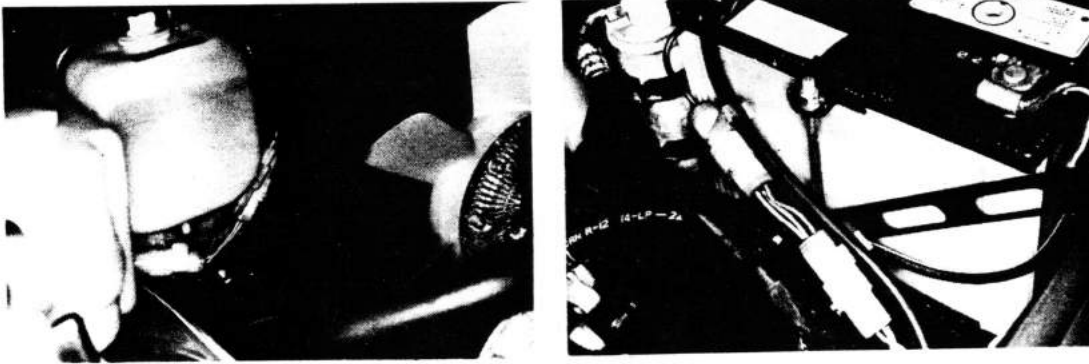

FJ Series

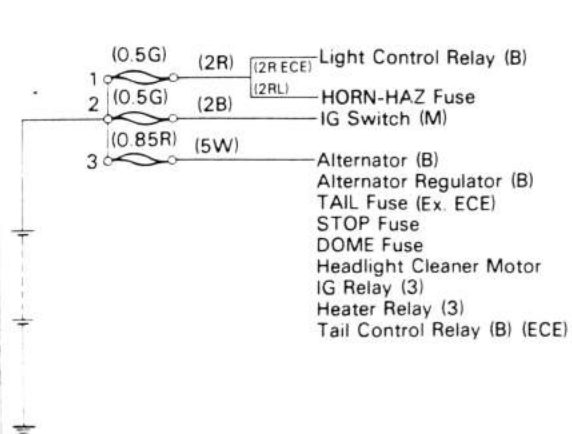

BJ, HJ Series

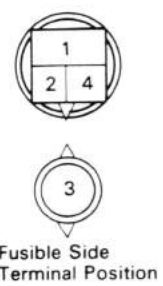
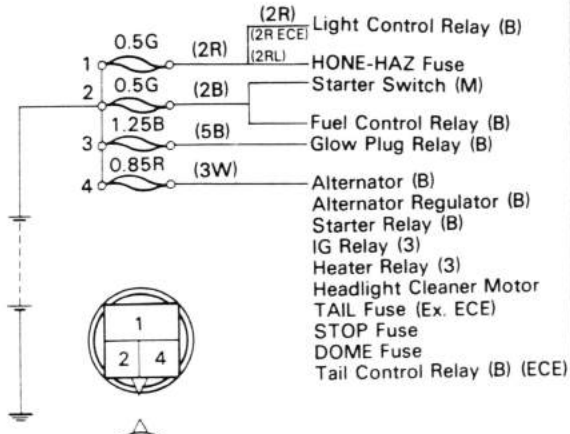

FUSE BLOCK

REPLACE FUSE

Install new fuse with correct amperage rating.

— Caution —

Turn off all electrical components and ignition switch before replacing a fuse. Do not exceed the fuse amp rating.

If a fuse continues to blow, a short circuit is indicated. The system must be checked by a qualified technician.

FUSE BLOCK LOCATION

Fig. 13-17

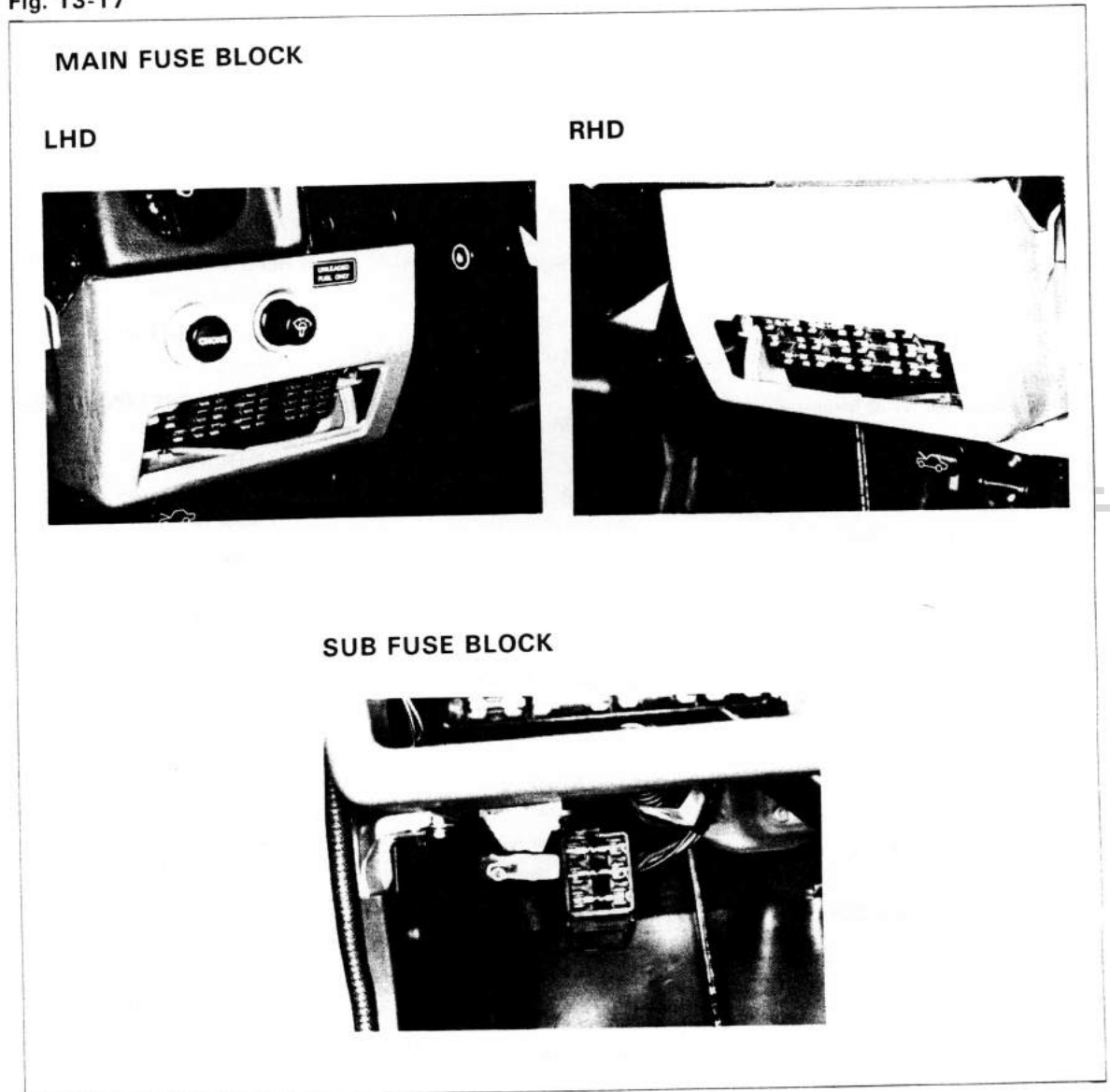

Fuses & Circuits

Each fuse is connected to the following circuits.

FJ Series

[From IG SWITCH (IG)]

GAUGES 5A

Oil Pressure Gauge
Water Temperature Gauge
Fuel Gauge
Bolt Gauge
Tachometer
Charge Light
Brake Fluid Level Indicator Light
IG Relay
Heater Relay
Brake Warning Light (ARL)
Parking Brake Indicator Light (ARL)

CHARGE 5A

Charge Light
Alternator Regulator (L)

CHARGE 5A (W/IC Regulator)

Alternator (L)
Charge Light Relay (A)

TURN 10A

Turn & Hazard Switch (B₁)

WIPER 15A

Fr. Wiper Switch (B)
Wiper Control Relay (B)
Fr. Wiper Motor (B)
Fr. Washer Motor
Rr. Wiper Switch
Rr. Wiper Motor
Backup Light Switch
Rr. Heater Blower Motor
Headlight Cleaner
Electric Winch Control Switch (B)

[From IG SWITCH (ACC)]

RADIO 5A

Radio
Stereo

CIGL 15A

Cigarette Lighter
Mirror Antenna

[From FUSIBLE LINK (0.5) G]

HORN HAZ 10A

Turn & Hazard Switch (B₁)
Horn

[From FUSIBLE LINK (0.85) R]

TAIL 15A

Tail Light Relay
To
Headlight Cleaner Control Relay
Glovebox Light
Tail Light
Clearance Plate Light
License Light
Fr. Side Marker Light
Rr. Side Marker Light
Defogger Light
Speedometer Light
Combination Meter Light
Tachometer Light
Heater Control Light
Cigarette Lighter Light

STOP 10A

Stop Light Switch

DOME 5A

Inspection Socket
Interior Light
Luggage Compartment Light
Cooling Fan Computer (USA)
Cooling Fan Relay (USA)

[From HEATER RELAY]

A/C 10A

Air Conditioner

[From IG RELAY]

ENGINE 10A

Outvent Valve
Fuel Cut Solenoid
Alternator Regulator (IG)
Charge Light Relay (IG)
Seat Belt Warning Relay
Emission Control Computer
Cooling Fan Computer (USA)

DEFOG 20A

Defogger Switch

[From LIGHT RELAY]

HEAD LH 10A

Headlight LH

HEAD RH 10A

Headlight RH

[From DIMMER RELAY]

(ECE)

HEAD (LH) Lo (10A)

Headlight LH Lo

HEAD (RH) Lo (10A)

Headlight RH Lo

HEAD (LH) Hi (10A)

Headlight LH Hi

HEAD (RH) Hi (10A)

Headlight RH Hi

[From TAIL LIGHT CONTROL RELAY]

(ECE)

TAIL LH (10A)

Tail Light LH

Clearance Light LH

TAIL RH (10A)

Headlight Cleaner Control Relay

Tail Light (RH)

Clearance Light (RH)

License Plate Light

Speedometer Light

Cigarette Lighter Light

Glovebox Light

Heater Control Light

Combination Meter Light

Tachometer Light

BJ, HJ Series

[From STARTER SWITCH (G)]

- GLOW 5A**
 Glow Plug Relay (G)
 Glow Indicator Light
 Glow Timer

[From STARTER SWITCH (ST)]

- STARTER 5A**
 Glow Plug Relay (ST)
 Fuel Control Relay (ST B)
 Starter Relay (ST)
 Brake Warning Valve Check Relay (ARL)

[From IG RELAY]

- ENGINE 15A**
 Alternator Regulator (IG)
 Oil Pressure Gauge
 Water Temperature Gauge
 Fuel Gauge
 Bolt Gauge
 Sediment Indicator Light
 Tachometer
 Charge Light
 Brake Indicator Light
 Seat Belt Warning Relay (Canada)
 Brake Warning Light (ARL)
 PKD Light
 Alternator (IG) W/IC
 Charge Light Relay (IG) Regulator

- CHARGE 5A**
(W/O IC Regulator)
 Charge Light
 Alternator Regulator (L)

- CHARGE 5A**
(W/IC Regulator)
 Alternator (L)
 Charge Light Relay (A)

[From STARTER (ON)]

- TURN 10A**
 Turn & Hazard Switch (B)

- WIPER 15A**
 Fr. Wiper Switch (B)
 Fr. Wiper Motor
 Fr. Washer Motor
 Rr. Wiper Switch (B)
 Rr. Wiper Motor
 Rr. Washer Motor
 Back-up Switch
 Rr. Heater Blower Motor
 Electric Winch Control Switch (B)

[From STARTER SWITCH (ACC)]

- RADIO 5A**
 Resister 24V only
 Radio
 Stereo

- CIG.L 15A**
 Cigarette Lighter
 Motor Antenna

[From FUSIBLE LINK (0.85)]

- TAIL 15A**
 Tail Light Relay
 To
 Glovebox Light
 Tail Light
 Clearance Light
 License Plate Light
 Fr. Side Marker
 Rr. Side Marker Light
 Defogger Light
 Speedometer Light
 Combination Light
 Tachometer Light
 Heater Control Light
 Cigarette Lighter Light

IC Rheostat

- STOP 10A**
 Stop Light Switch

- DOME 5A**
 Inspection Socket
 Interior Light
 Luggage Compartment Light

- [From FUSIBLE LINK (0.5)]
HORN-HAZ 10A
 Turn & Hazard Switch (B₂)

- [From HEATER RELAY]
 A/C 10A
 Air Conditioner

- [From IG RELAY]
DEFOG 20A
 Defogger Relay

[From LIGHT CONTROL RELAY]

- HEAD LH 10A**
 Headlight LH
HEAD RH 10A
 Headlight RH

[From DIMMER RELAY] (ECE)

- HEAD (LH) Lo (10A)**
 Headlight LH Lo
HEAD (RH) Lo (10A)
 Headlight RH Lo
HEAD (LH) Hi (10A)
 Headlight LH Hi
HEAD (RH) Hi (10A)
 Headlight RH Hi

[From TAIL LIGHT CONTROL RELAY] (ECE)

- TAIL LH (10A)**
 Tail Light LH
 Clearance Light LH

- TAIL RH (10A)**
 Headlight Cleaner Relay
 Tail Light (RH)
 Clearance Light (RH)
 License Plate Light
 Speedometer Light
 Cigarette Lighter Light
 Glovebox Light
 Heater Control Light
 Combination Meter Light
 Tachometer Light
 Voltage Converter (24V)

cardiagn.com

IGNITION SWITCH CIRCUIT DIAGRAM

Fig. 13-18

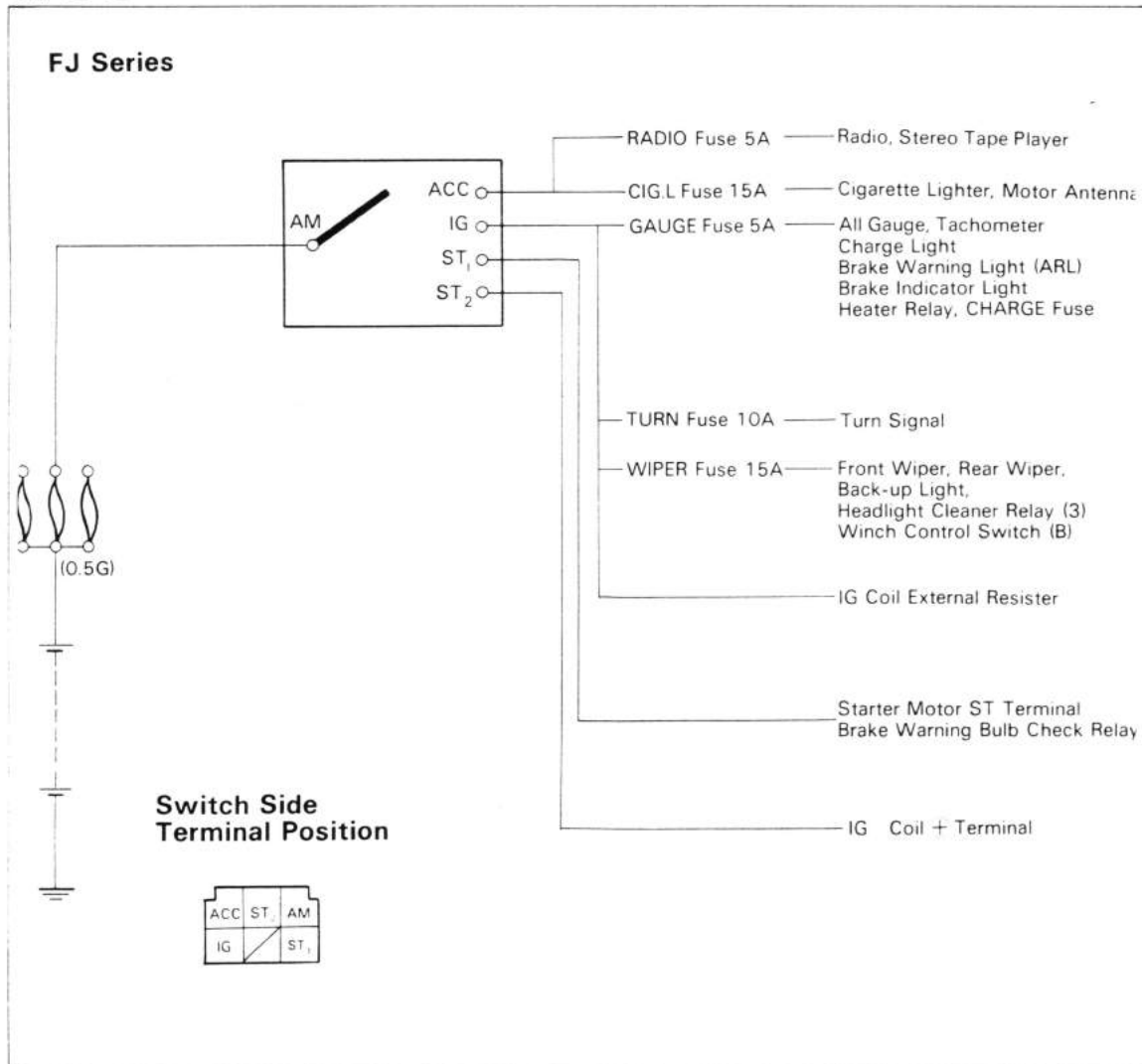
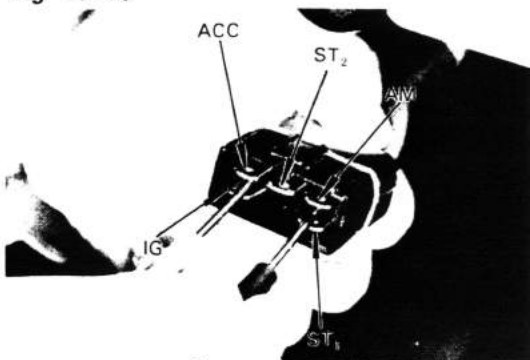

Fig. 13-19



ON-VEHICLE INSPECTION



Check continuity between terminals.

Terminal Position \ Terminal	AM	ACC	IG	ST1	ST2
LOCK					
ACC	○—○				
ON	○—○—○				
START	○—○—○—○—○				

CIRCUIT DIAGRAM

Fig. 13-20

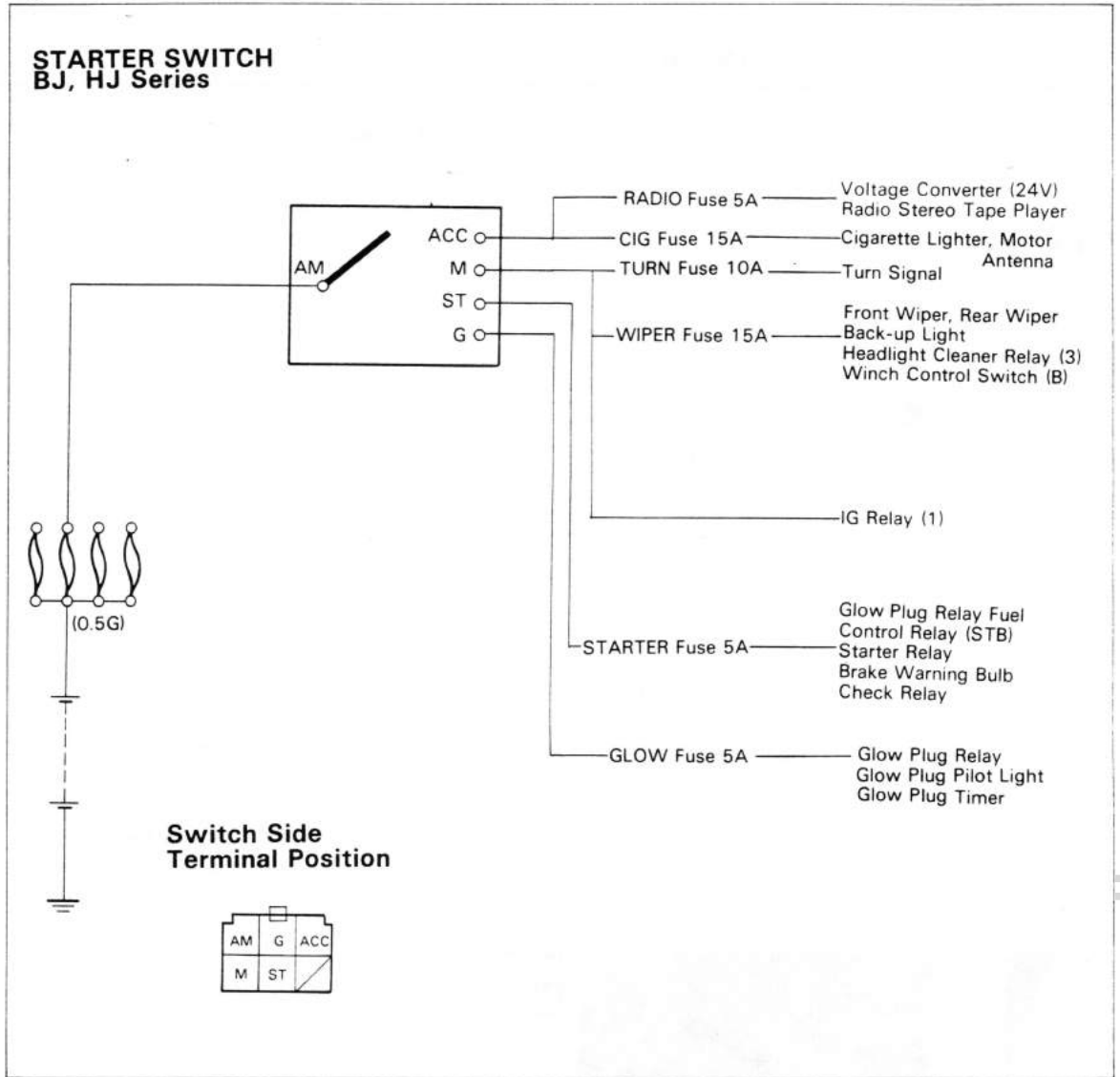
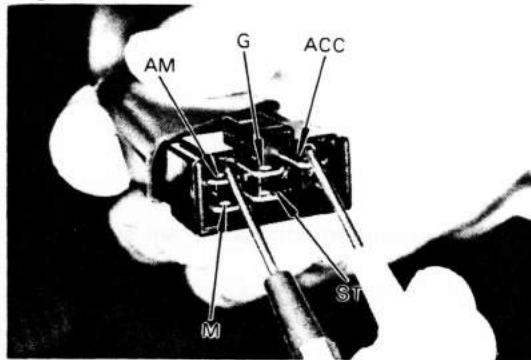

Fig. 13-21



ON-VEHICLE INSPECTION



Check continuity between terminals.

Terminal Position	AM	ACC	M	G	ST
LOCK					
ACC	○—○				
ON	○—○—○				
GLOW	○—○—○—○				
START	○—○—○—○—○				

cardiagn.com

REMOVAL

Remove the parts in the numerical order shown in the figure.

Fig. 13-22

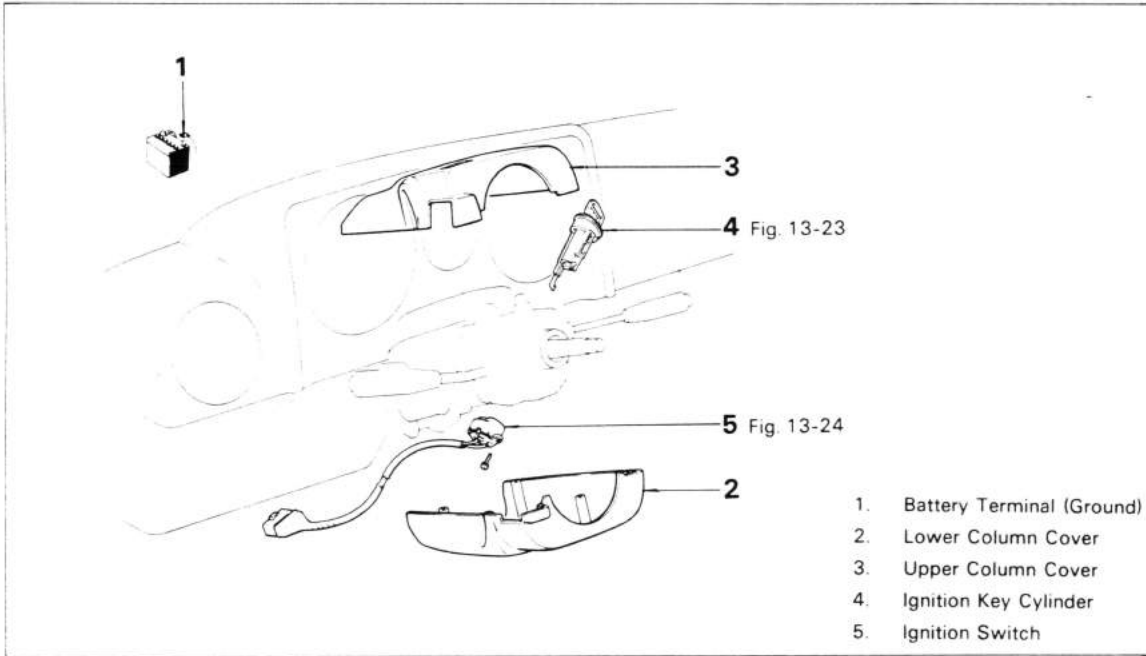

Fig. 13-23



Turn ignition key to ACC and with the pin pushed in with a wire, pull out the key cylinder.

Fig. 13-24



Remove the ignition switch set screw.

INSTALLATION

Install the parts in the numerical order shown in the figure.

Fig. 13-25

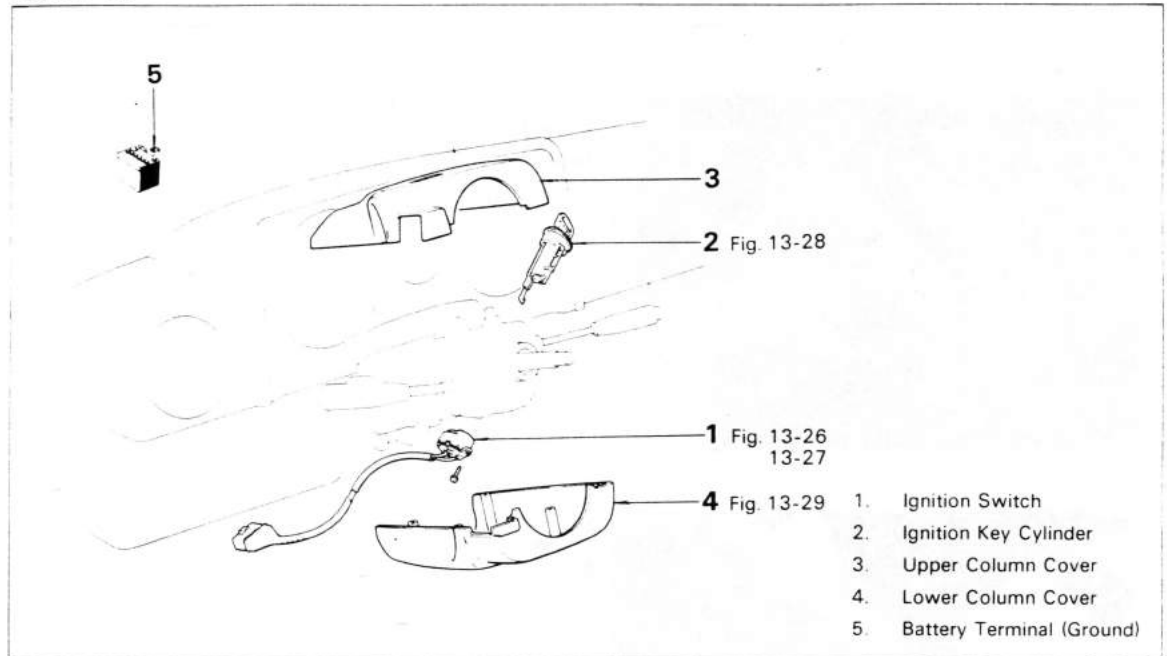
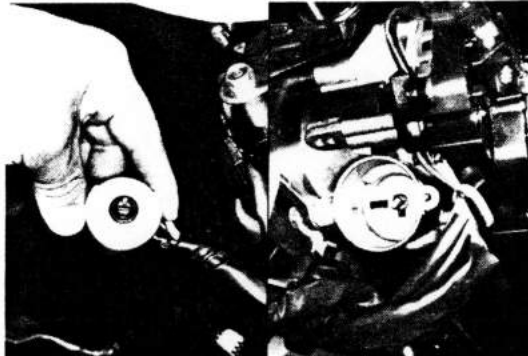
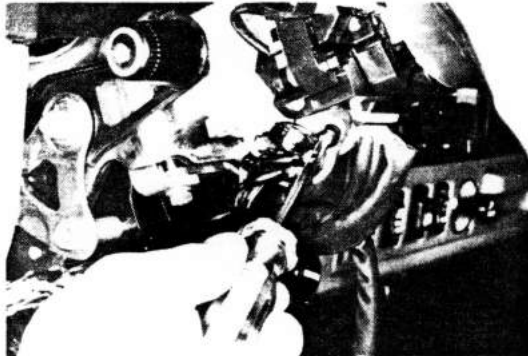

Fig. 13-26



Install the ignition switch with the switch recess and the bracket tab correctly positioned.

Fig. 13-27



Install the ignition switch.

Fig. 13-28

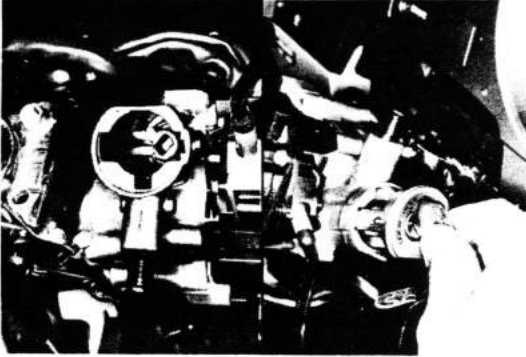

Position the bracket as shown in the left figure.
With the key in the ACC position, install the key cylinder.

Fig. 13-29

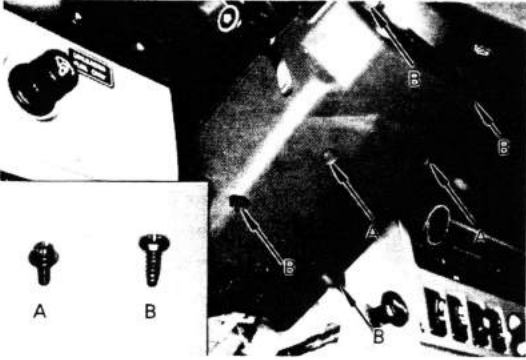

Install the cover set screws as shown in the figure.

Fig. 13-30



Fig. 13-31

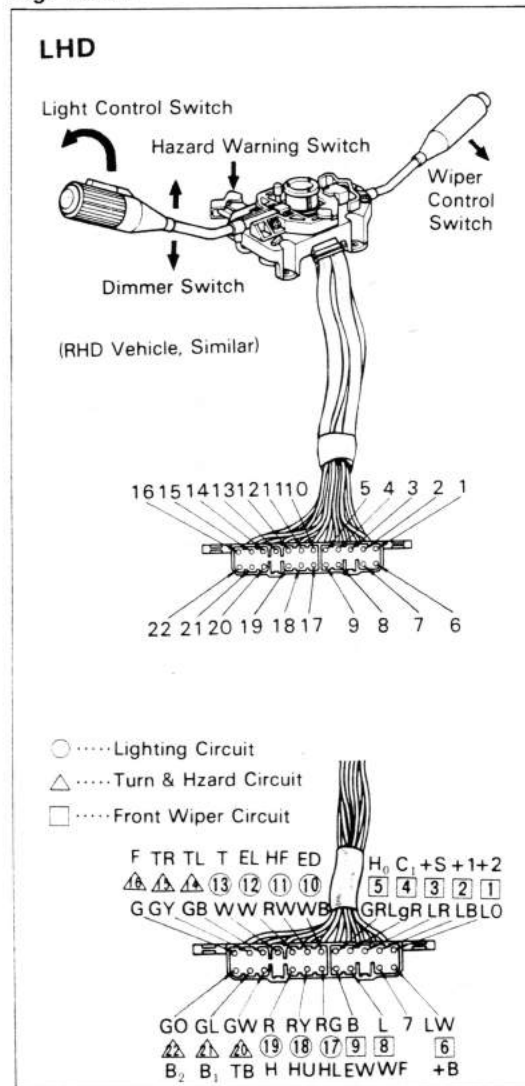

COMBINATION SWITCH



INSPECTION

Remove the following parts.

1. Column cover
2. Wiring connector
3. Connector

Check the continuity between the terminals. If there is continuity between the terminals as shown in the table below, the switch is in good condition.

Light control & dimmer switch

Switch position	Terminal (Wire color) (No.)	T (W) (12)	H (R) (19)	EL (W) (13)	ED (WB) (10)	HU (R) (18)	HL (RG) (17)	HF (RW) (11)
	Light control	OFF						
	ONE STEP	○	○					
	TWO STEP	○	○	○				
Dimmer	Headlight U				○	○		
	Headlight L				○	○	○	
	Headlight F				○	○	○	

Turn signal & hazard warning switch

Switch Position	Terminal (Wire color) (No.)	TL (GB) (14)	TB (GW) (20)	TR (GY) (15)	B1 (GL) (21)	F (G) (16)	B2 (GO) (22)
	Turn	R		○	○	○	○
N					○	○	
Signal	L	○	○		○	○	
	Hazard	○	○	○		○	○

Wiper control switch

Switch position	Terminal (Wire color) (No.)	B (LW) (6)	+S (LR) (3)	+1 (LB) (2)	+2 (LO) (1)	C _q (LgR) (4)	E _w (B) (9)	W _F (L) (8)
	OFF			○	○			
*INT			○	○		○		
LO		○		○				
HI		○			○			
WASHER								○

*...Intermittent Type.

cardiagn.com

REMOVAL

Remove the parts in the numerical order shown in the figure.

Fig. 13-32

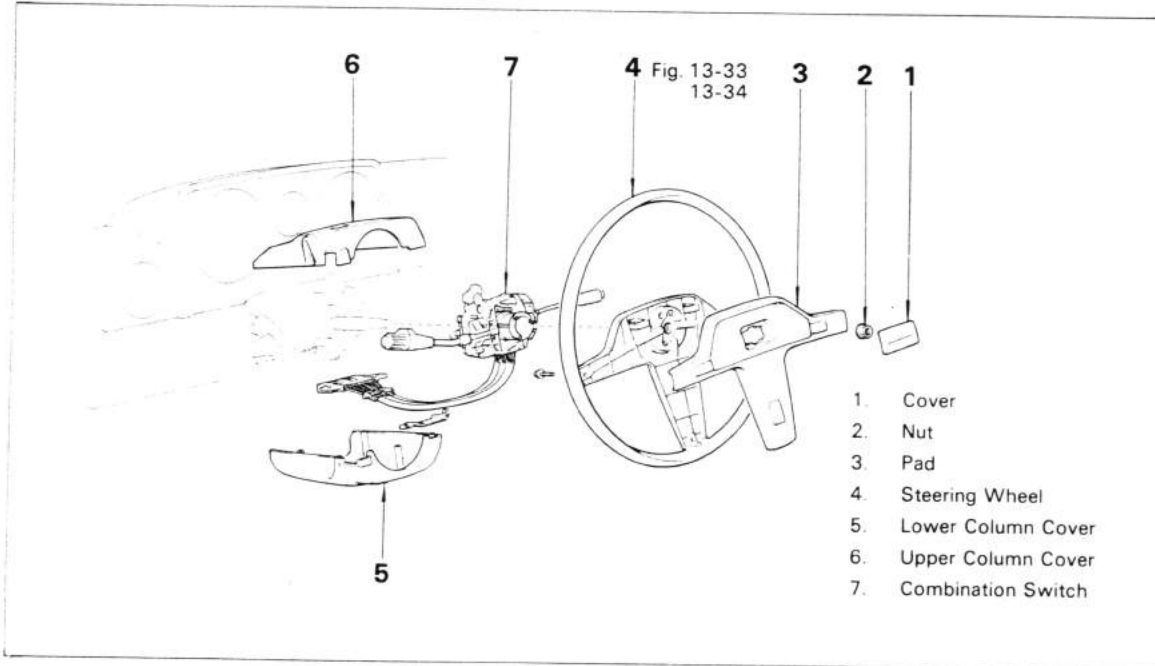
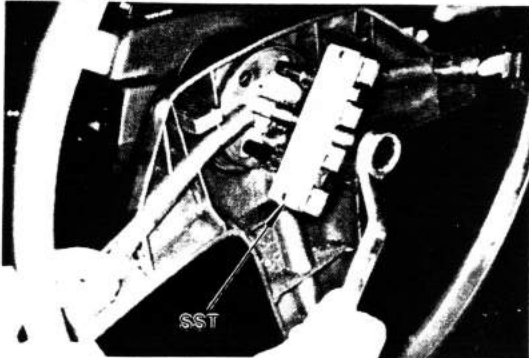

Fig. 13-33



Place matchmarks on the steering wheel and the steering shaft.

Fig. 13-34



Remove steering wheel with SST.
SST [09609-20010]

DISASSEMBLY

Disassemble the parts in the numerical order shown in the figure.

Fig. 13-35

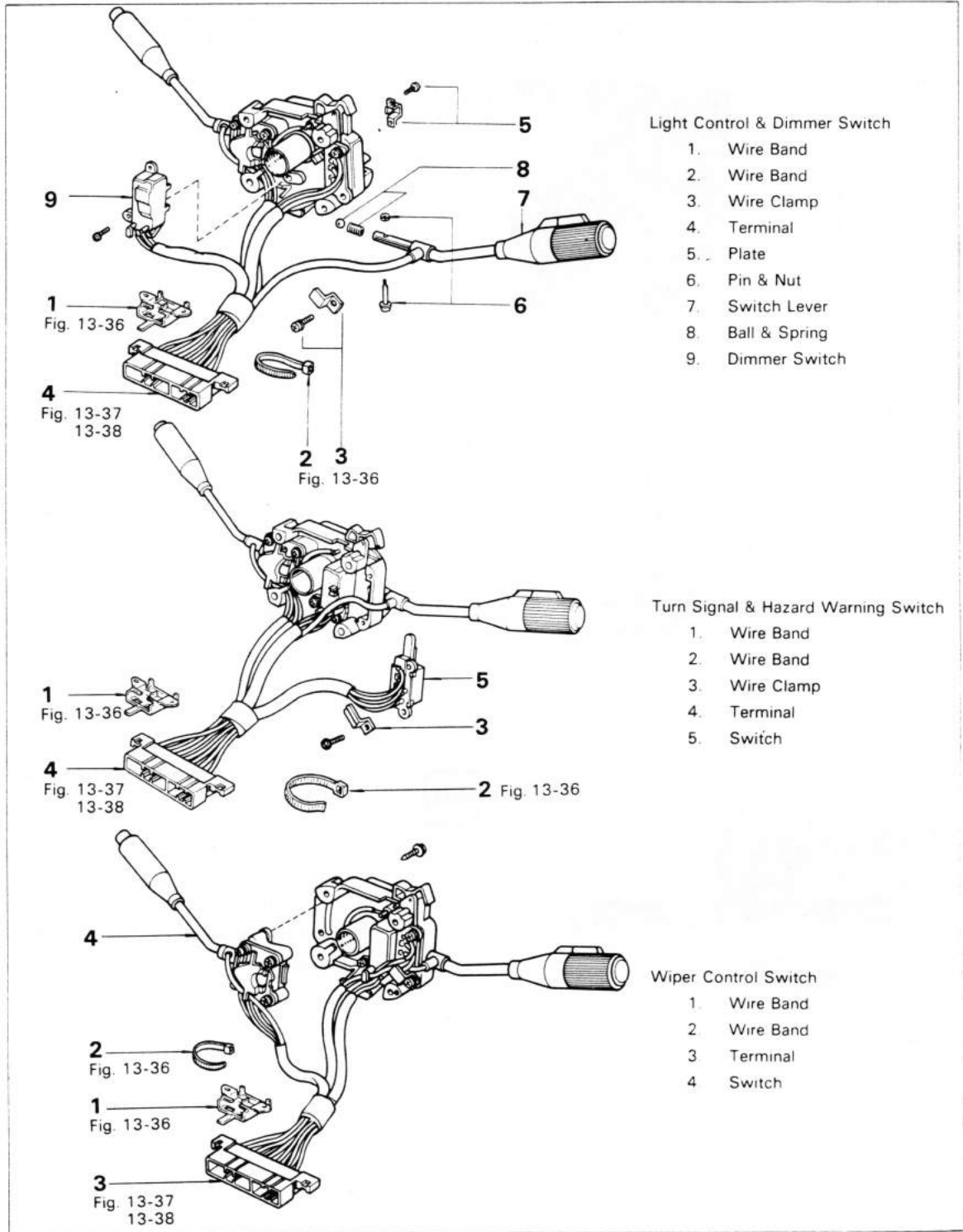
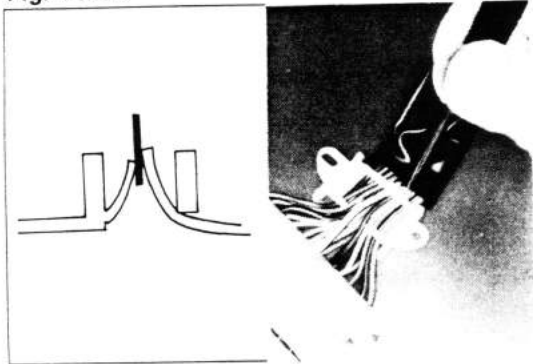
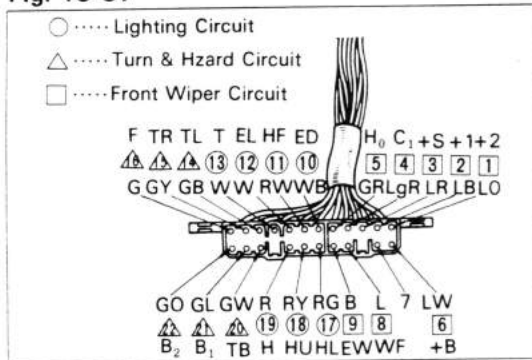

Fig. 13-36



Remove the wiring band with screwdriver.

Fig. 13-37



Each terminal of circuit is installed following number.

Light control & Dimmer switch

○ mark 10, 11, 12, 13, 17, 18, 19

Turn signal & Hazard warning switch

△ Mark 14, 15, 16, 20, 21, 22

Wiper control switch

□ Mark 1, 2, 3, 4, 6, 8, 9

Fig. 13-38

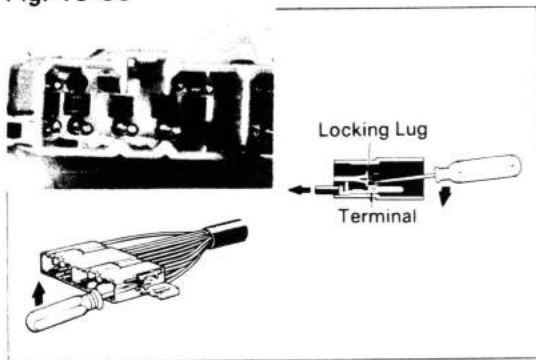

Remove the terminals from the bulkhead connector.

1. From the open end, insert a miniature screwdriver between the locking lugs and terminal.

2. Pry up the locking lugs with the screwdriver and pull the terminal out from the rear.

ASSEMBLY

Assemble the parts in the numerical order shown in the figure.

Fig. 13-39

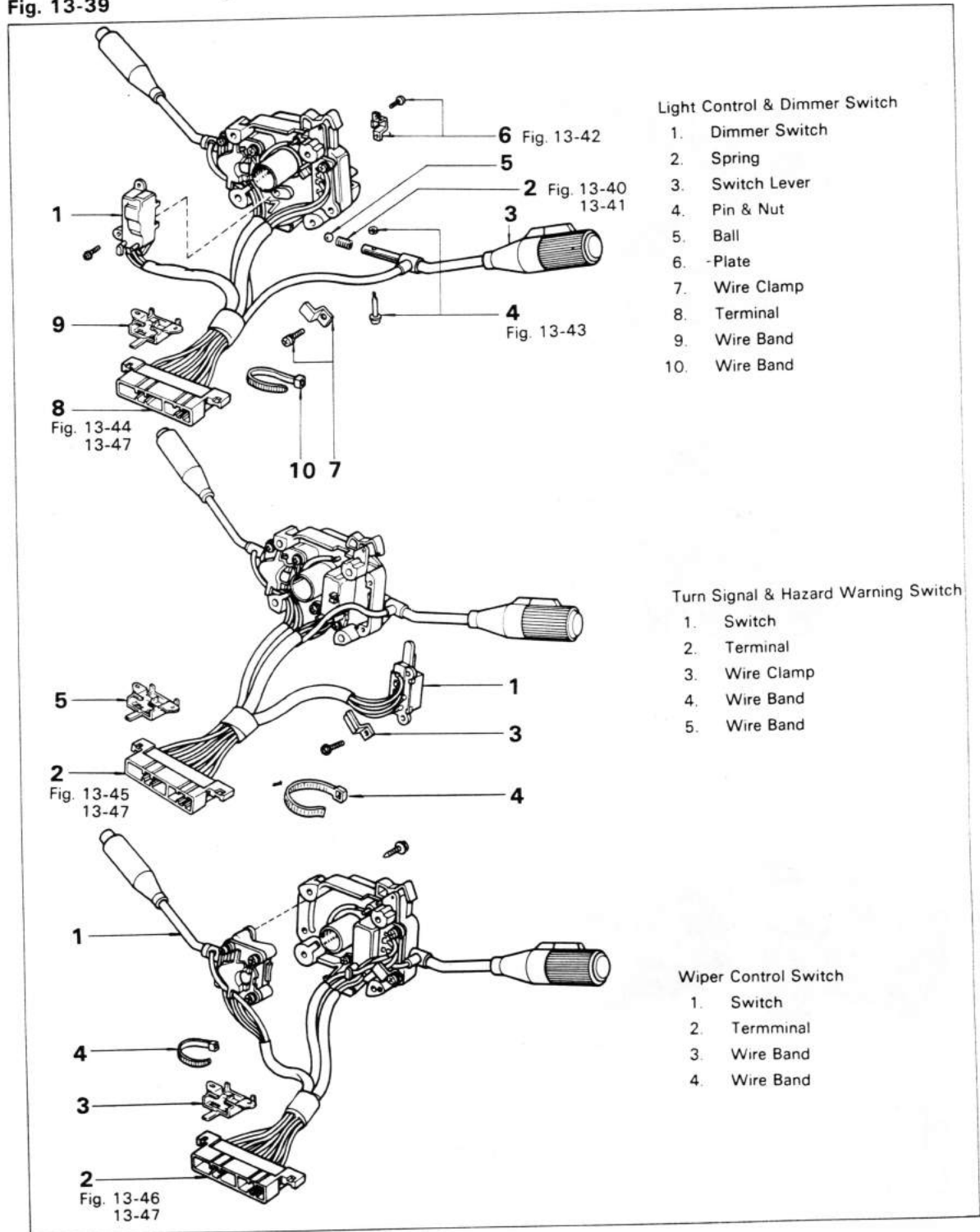

Light Control & Dimmer Switch

- 1. Dimmer Switch
- 2. Spring
- 3. Switch Lever
- 4. Pin & Nut
- 5. Ball
- 6. Plate
- 7. Wire Clamp
- 8. Terminal
- 9. Wire Band
- 10. Wire Band

Turn Signal & Hazard Warning Switch

- 1. Switch
- 2. Terminal
- 3. Wire Clamp
- 4. Wire Band
- 5. Wire Band

Wiper Control Switch

- 1. Switch
- 2. Terminal
- 3. Wire Band
- 4. Wire Band

cardiagn.com

Fig. 13-40



Install the spring into the lever.

Fig. 13-41

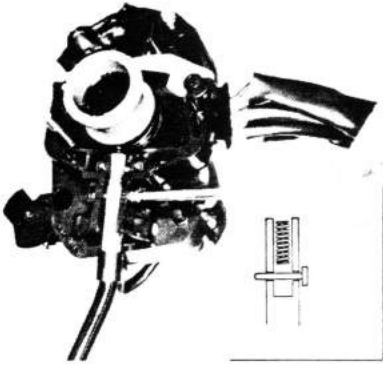

Place the spring position as shown in the figure when installing the switch lever.

Fig. 13-42

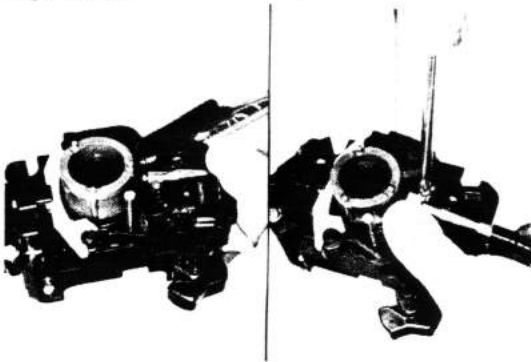

Put on the steel ball on the spring and install the plate while turn on the lever in the Hi beam side.

Fig. 13-43

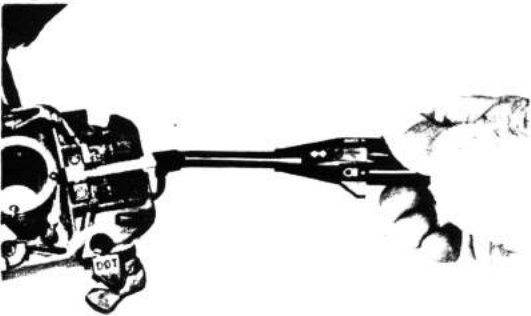

Insure that the switch operates smoothly.

Fig. 13-44

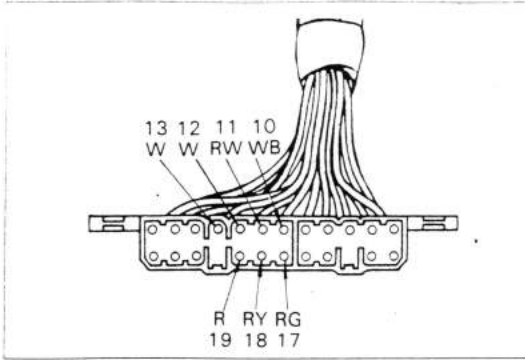

Install the lighting circuit terminals as shown in the figure.

Fig. 13-45

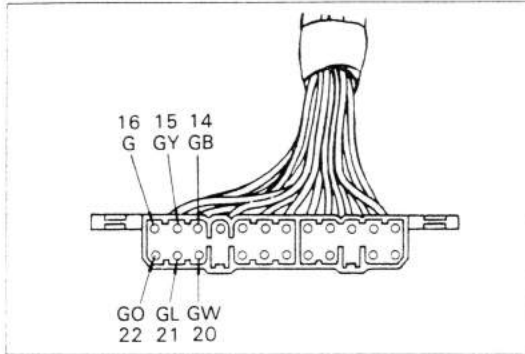

Install the turn signal and hazard warning circuit terminals as shown in the figure.

Fig. 13-46

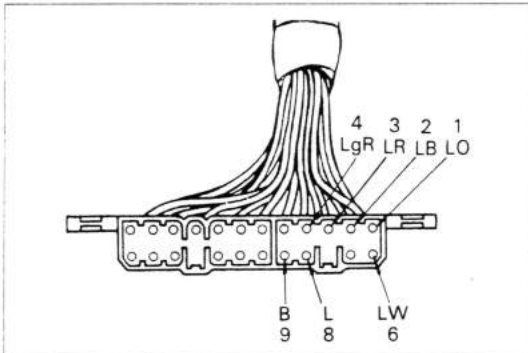

Install the front wiper circuit terminals as shown in the figure.

Fig. 13-47

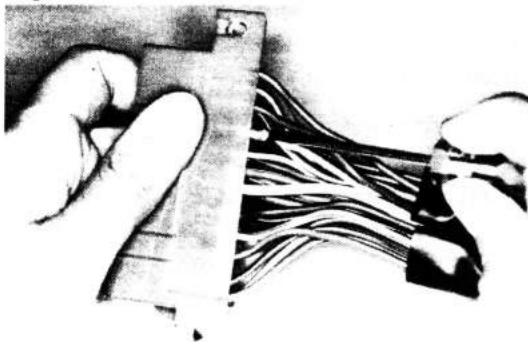

Insert the terminal until terminal is caught on a projection in the connector. Make sure that terminal is not removal.

INSTALLATION

Install the parts in the numerical order shown in the figure.

Fig. 13-48

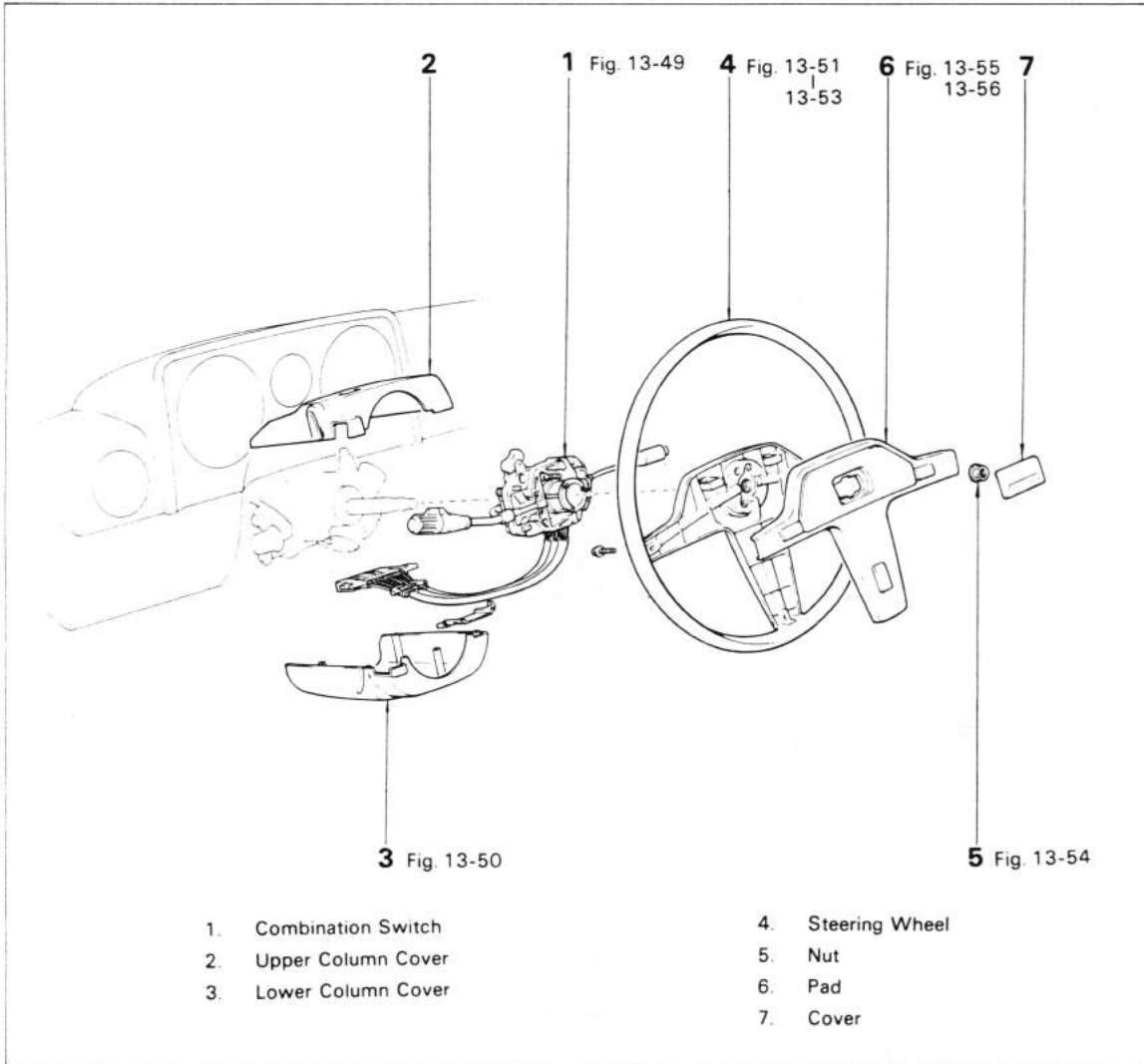
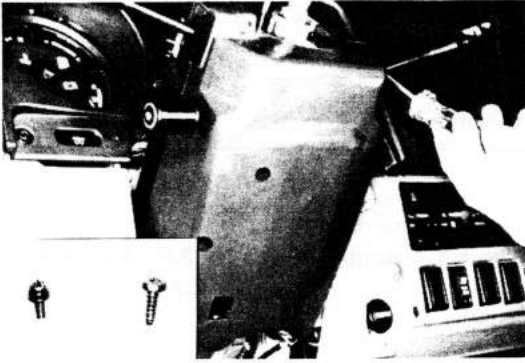

Fig. 13-49



Install the wire harness band and connector.

Fig. 13-50



Install the cover.

Fig. 13-51

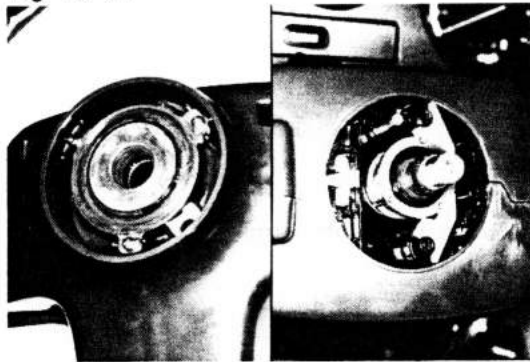

Align auto-cancel mechanism pin and hole.

Fig. 13-52

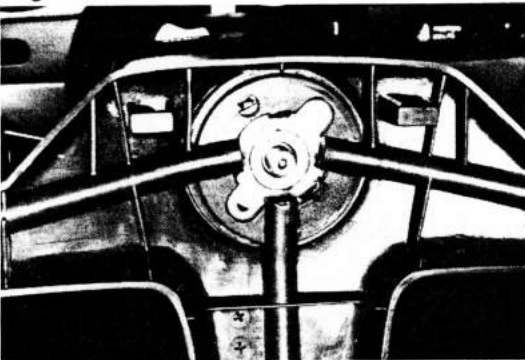

Align the matchmarks on main shaft and steering wheel.

Fig. 13-53

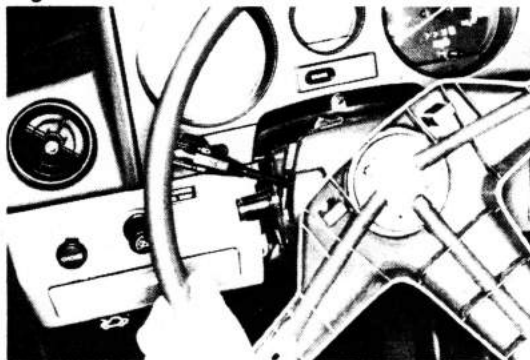

Check auto-cancel action.

Fig. 13-54

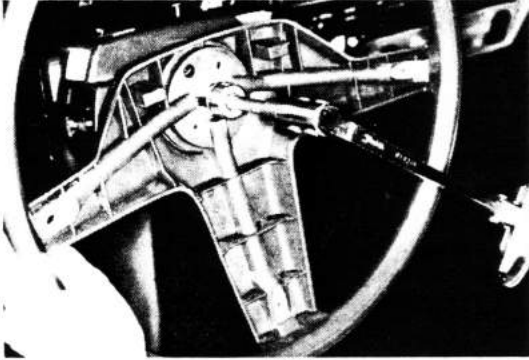

Tighten the nut.

Tightening torque: 3.0–4.0 kg-m
(22–28 ft-lb)

Fig. 13-55



Connect the horn terminal.

Fig. 13-56

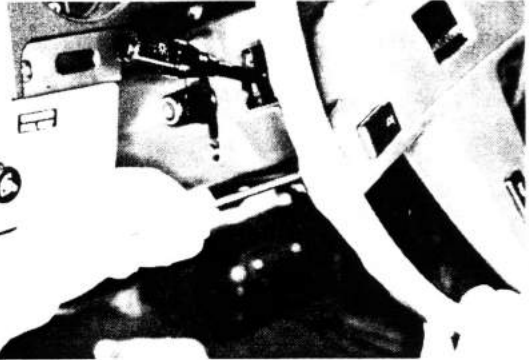

Install the pad set screw facing the back side.

LIGHTING CIRCUIT DIAGRAM

Fig. 13-57

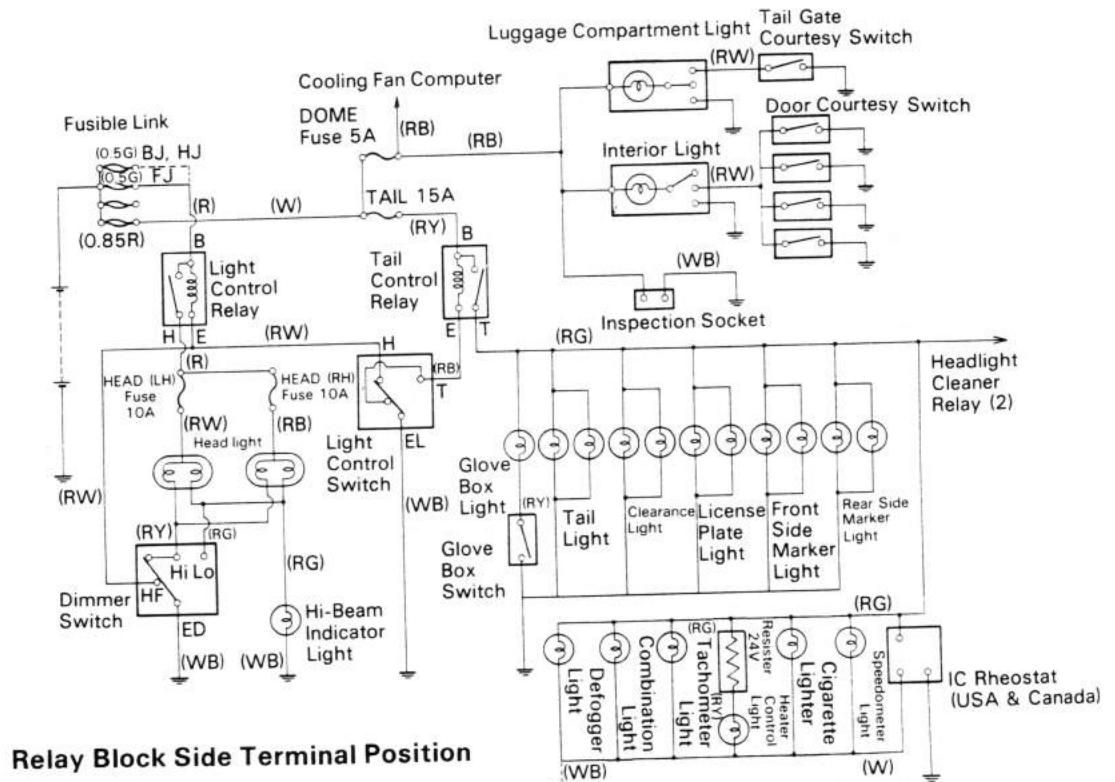
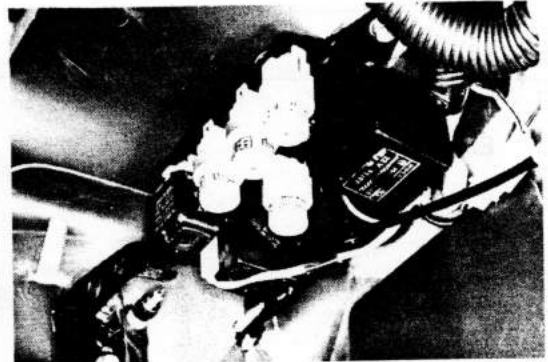
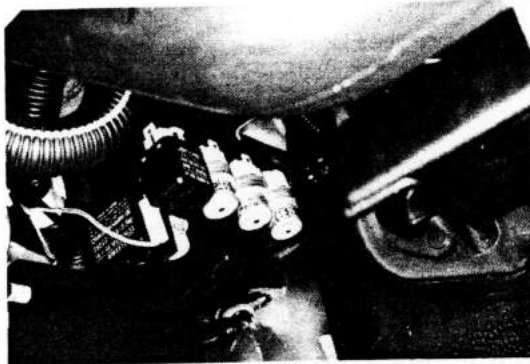

Relay Block Side Terminal Position

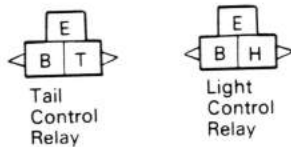

Except USA & Canada

cardiagn.com

Fig. 13-58

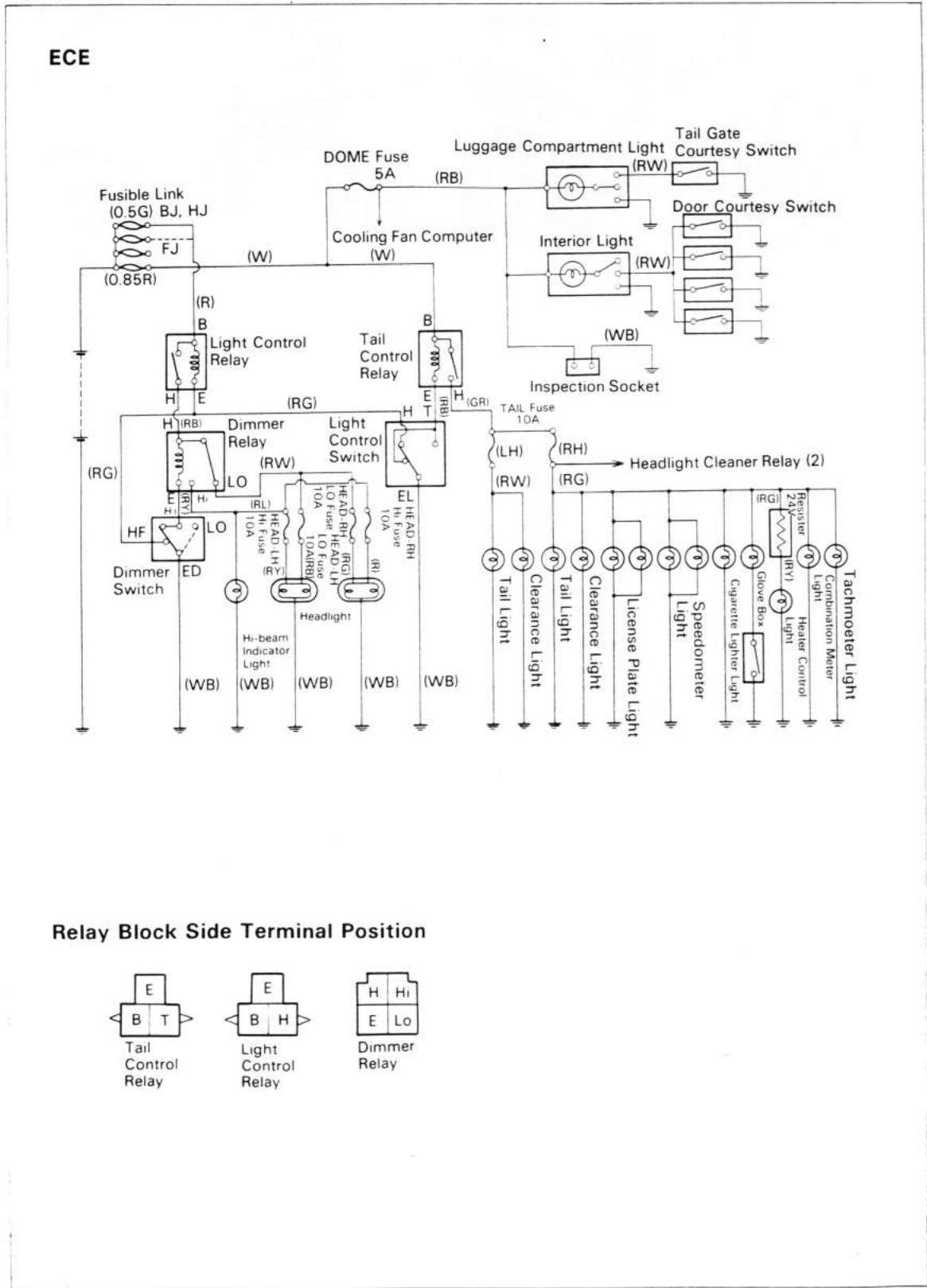
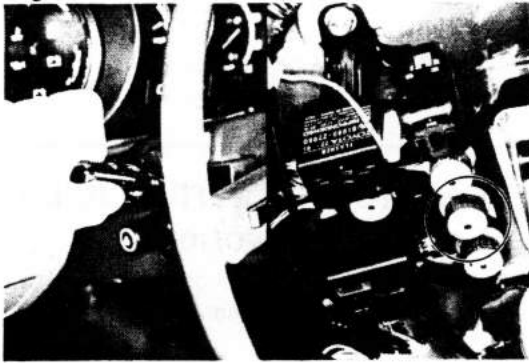

Fig. 13-59



TAIL LIGHT CONTROL RELAY ON-VEHICLE INSPECTION

1. Turn on the switch, check to see that there is an operational noise.

Fig. 13-60

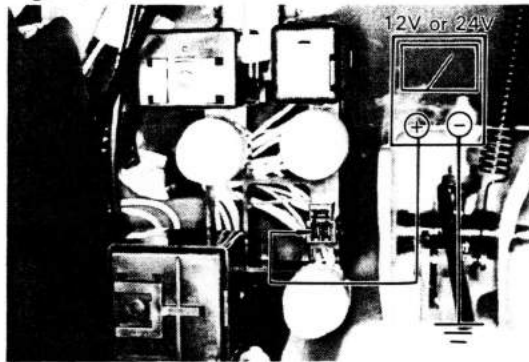

2. Battery voltage should be on terminal.

Fig. 13-61

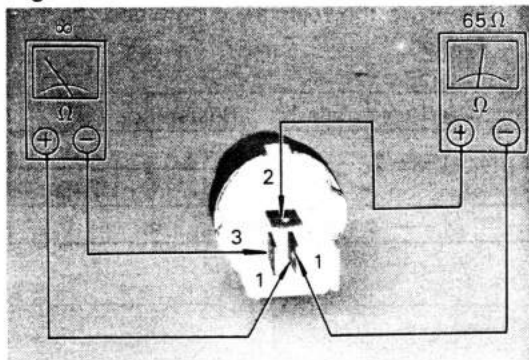

3. Measure the resistance between the terminals.

Between terminal	Resistance (Ω)	
	1 — 2	12V
	65	245
1 — 3	∞	

Fig. 13-62

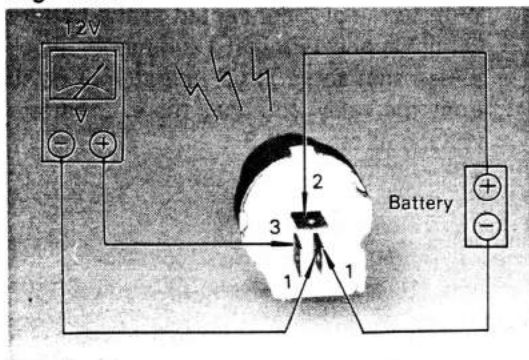

4. With terminal 2 connected to the battery (+) cable and terminal 1 grounded, check to see that there is an operational noise from the relay and that there is battery voltage at terminal 3.

Fig. 13-63

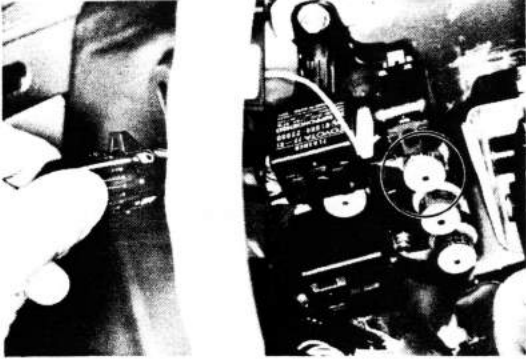

HEADLIGHT CONTROL RELAY

ON-VEHICLE INSPECTION

1. Turn on the switch, check to see that there is an operational noise.

Fig. 13-64

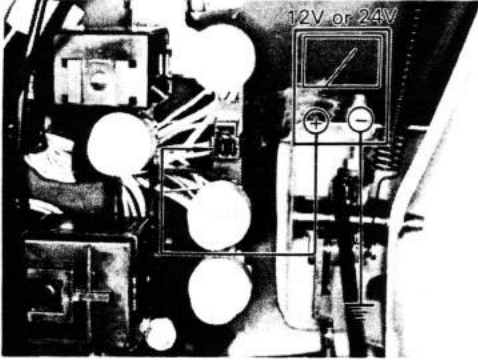

2. Battery voltage should be on terminal 1.

Fig. 13-65

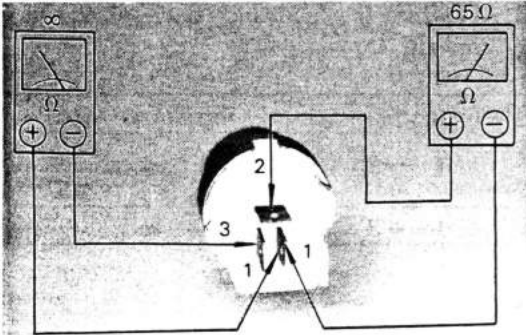

3. Measure the resistance between the terminals.

Between terminals	Resistance (Ω)	
	1 — 2	12V
	65	245
1 — 3	∞	

Fig. 13-66

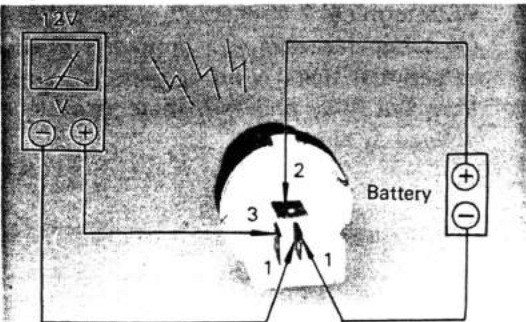

4. With terminal 2 connected to the battery (+) cable and terminal 1 grounded, check to see that there is an operational noise from the relay and that there is battery voltage at terminal 3.

Fig. 13-67

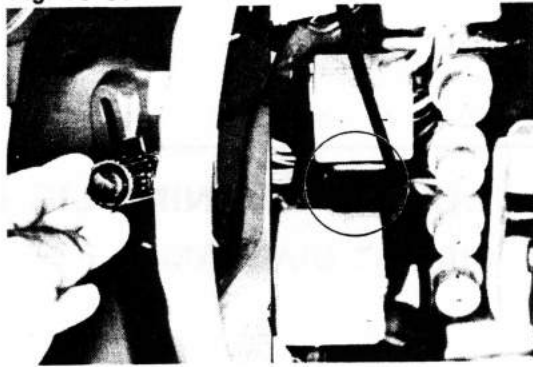

Fig. 13-68

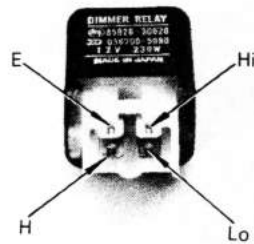
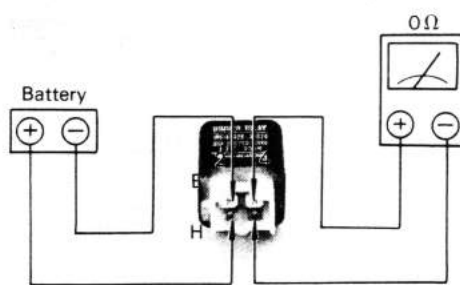

Fig. 13-69



HEADLIGHT DIMMER RELAY (Only Europe)



Turn on the dimmer switch check to see that there is an operating noise from the relay.



2. Measure resistance between terminals.

Between Terminals	Resistance (Ω)	
	12V	24V
H–E	15	226
H–Hi	∞	∞
H–Lo	0	0



3. With terminal H connected to the battery (+) cable and terminal E grounded. Check to see that there is an operating noise from the relay and that there is battery voltage at terminal Hi.

TURN SIGNAL & HAZARD WARNING LIGHT CIRCUIT DIAGRAM

Fig. 13-70

WITH 12V BATTERY

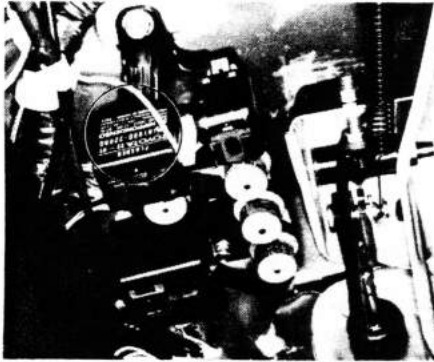

TURN SIGNAL FLASHER

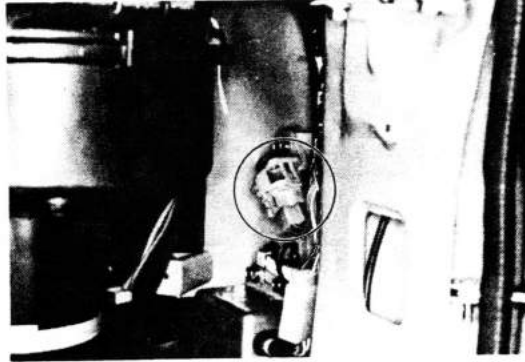

RED INDICATOR LIGHT RELAY

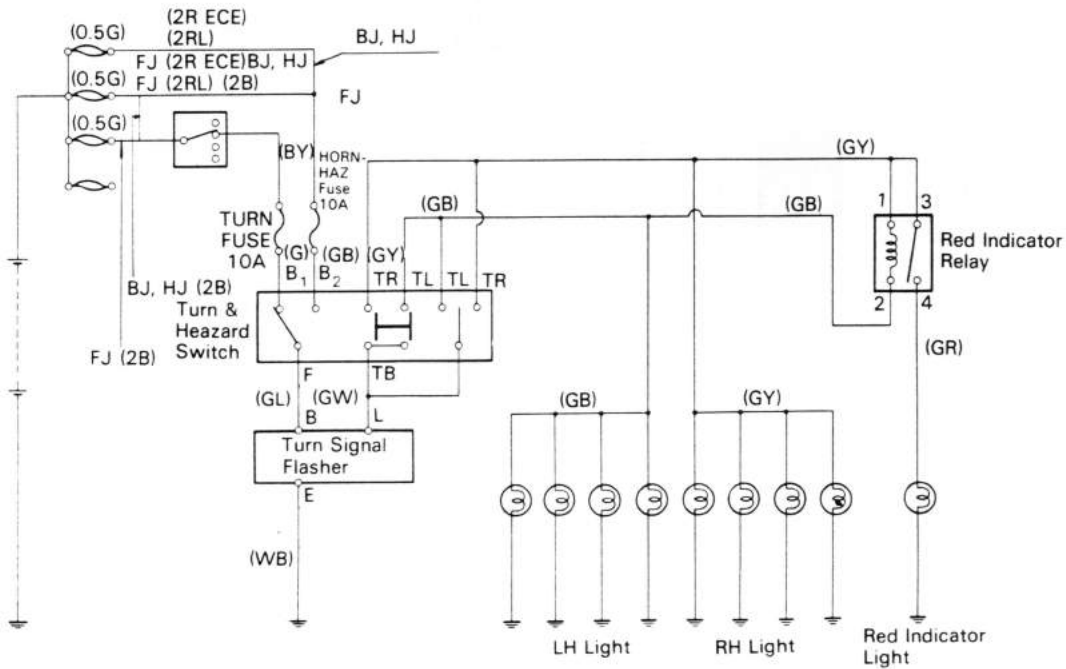

Relay Block Side Terminal Position

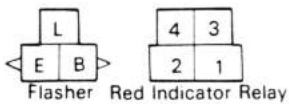

cardiagn.com

Fig. 13-71

WITH 24V BATTERY

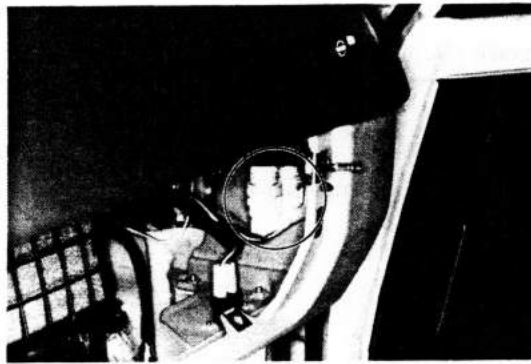

TURN SIGNAL RELAY

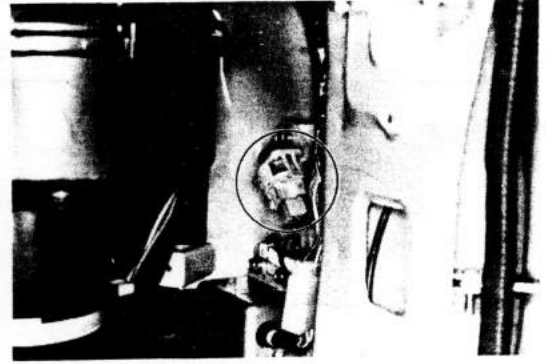

RED INDICATOR LIGHT RELAY

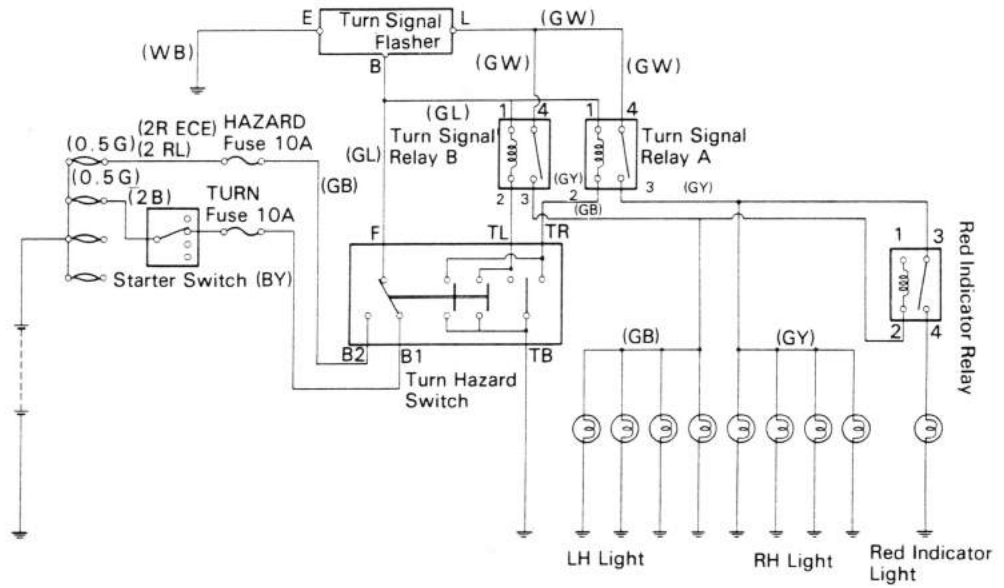

Relay Block Side Terminal Position

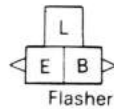

Flasher



Red Indicator Relay



Turn Signal Relay

cardiagn.com

Fig. 13-72

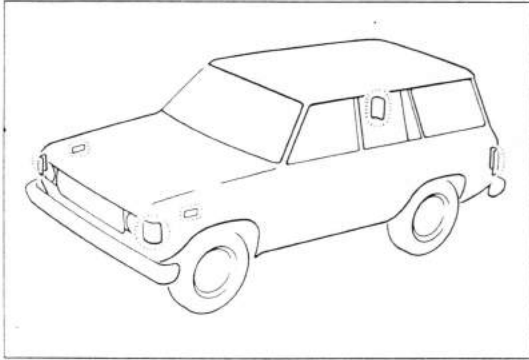

1. The turn signal lights should flash 70 – 100 times per minute.

Fig. 13-73

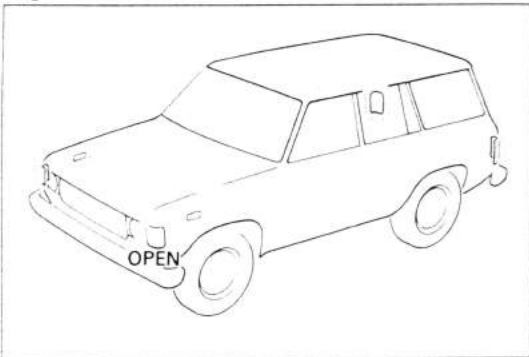

2. If one of the front or rear turn signal lights has an open circuit, the number of flashes should be more than 120 per minute.

Fig. 13-74

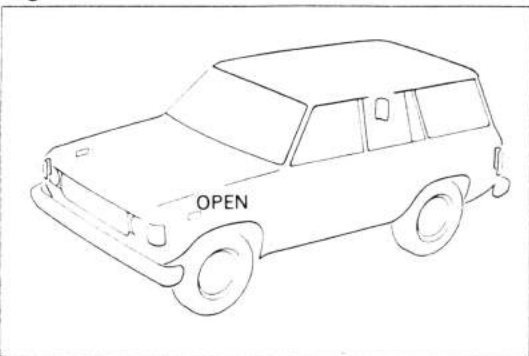

3. If one of the side turn signal lights has an open circuit, the number of flashes should increase by about 10 per minute.

Fig. 13-75

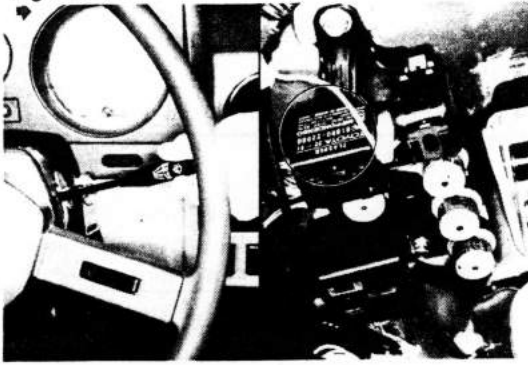

TURN SIGNAL FLASHER

INSPECTION

1. Turn on the switch, check to see that there is an operational noise.

Fig. 13-76

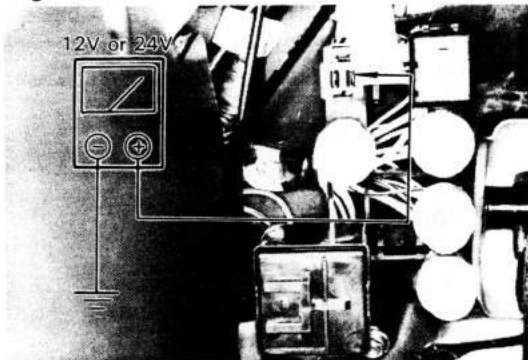

2. Battery voltage should be on terminal B.

Fig. 13-77

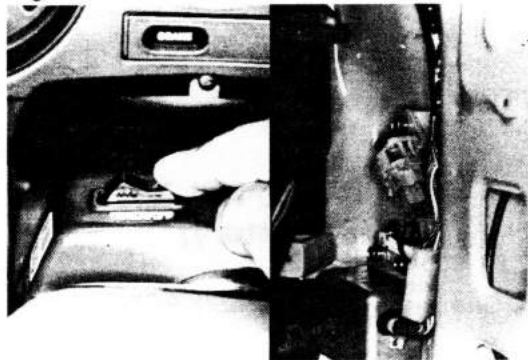

RED INDICATOR RELAY

INSPECTION

1. Turn on and off the hazard warning switch, check to see that there is an operational noise.

Fig. 13-78

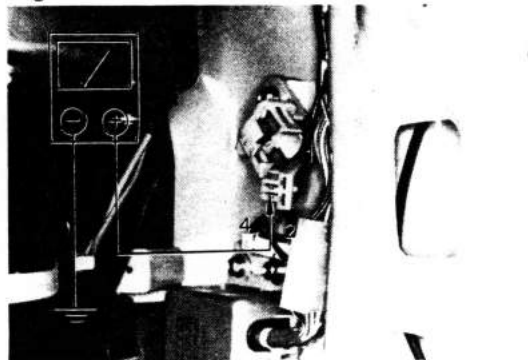

2. Battery voltage should be on terminal 1, 2 and 4.

Fig. 13-79

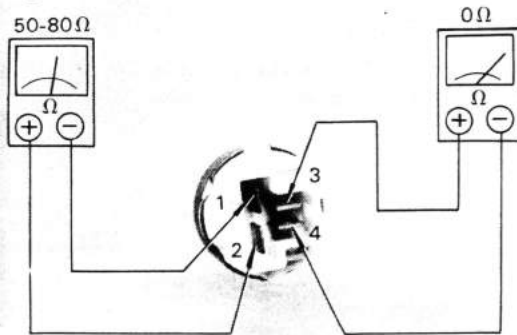

3. Check the resistance between terminals. If each resistance value as shown below, the relay is in good condition.

Between terminals	Resistance (Ω)
1 — 2	approx. 50-80
3 — 4	0

Fig. 13-80

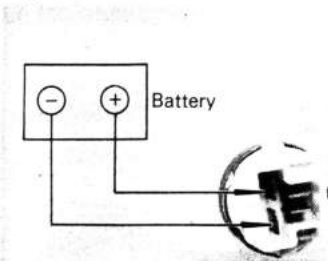

4. With terminal 1 connected to the battery (+) cable and terminal 2 (-) cable, check to see that there is an operational noise.

Fig. 13-81

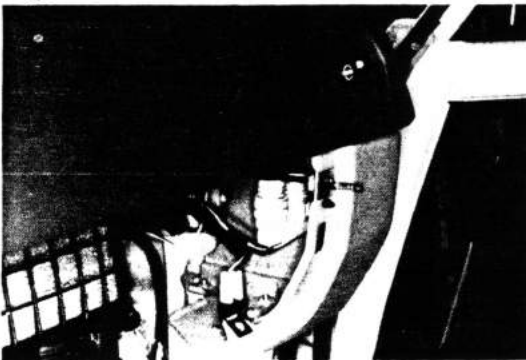

TURN SIGNAL RELAY (With 24V Battery)

The relays were installed near the glove compartment.

Fig. 13-82



Remove the relays and bracket together.

Fig. 13-83

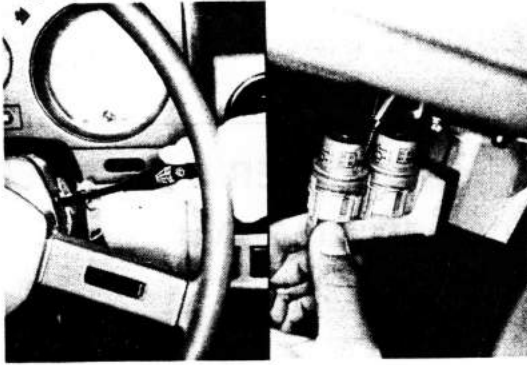

INSPECTION

1. Turn on and off the switch, check to see that there is an operational noise.

Fig. 13-84

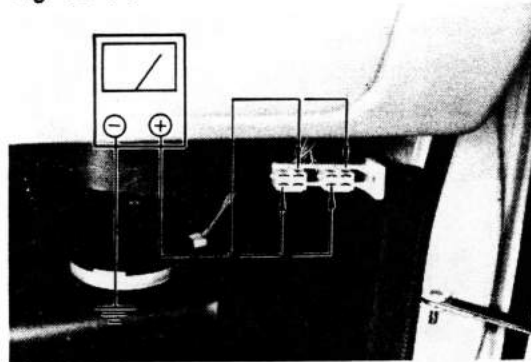

2. Battery voltage should be on terminal 1 and 4.

Fig. 13-85

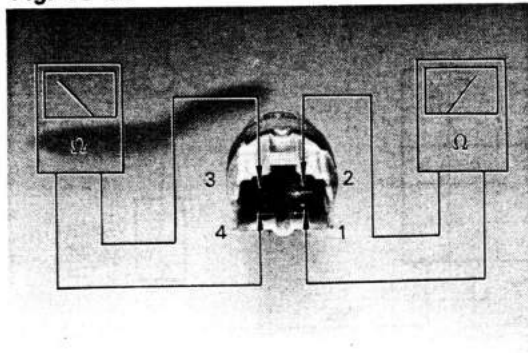

3. Check the resistance between terminals.

Between terminals	Resistance (Ω)	
	12V	24V
1 — 2	75	245
3 — 4	0	0

Fig. 13-86

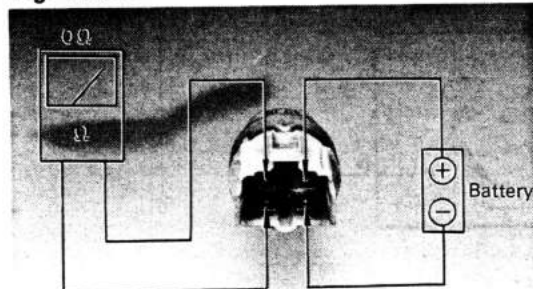

4. With terminal 2 connected to the battery (+) cable and terminal 1 cable, check to see that there is an operational noise from the relay.

FRONT WIPER & WASHER CIRCUIT DIAGRAM

Fig. 13-87

WITH 12V BATTERY

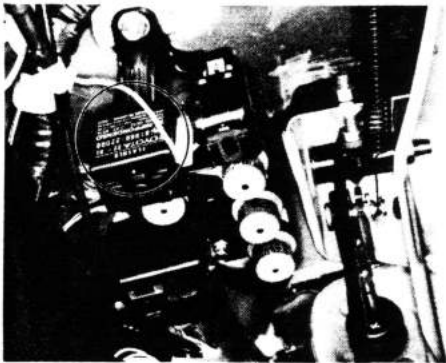

Wiper Control Relay

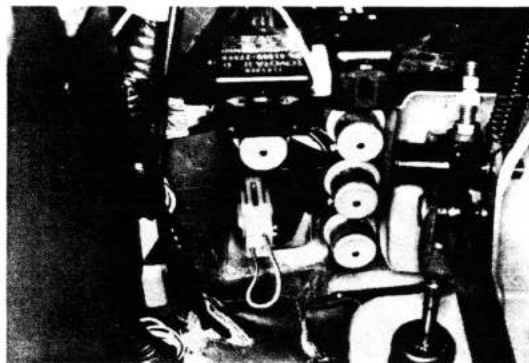

Without Relay

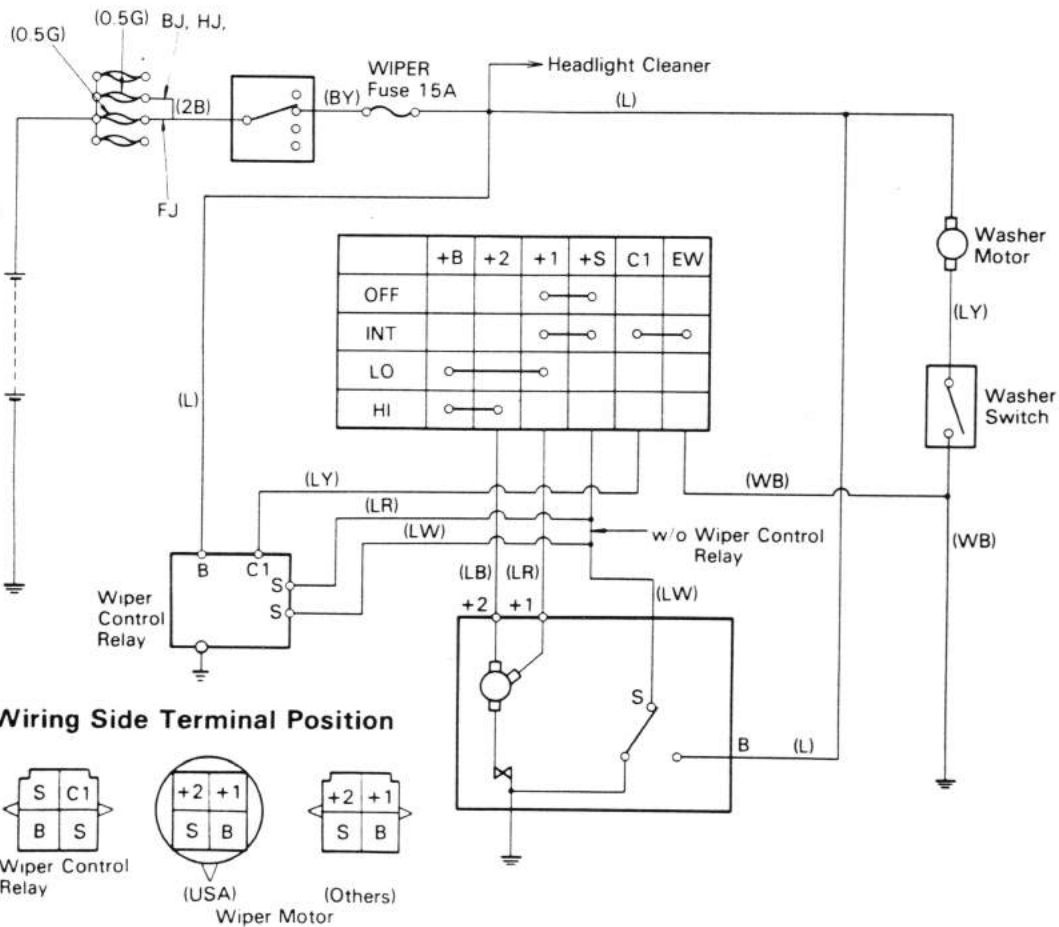

cardiagn.com

Fig. 13-88

WITH 24V BATTERY

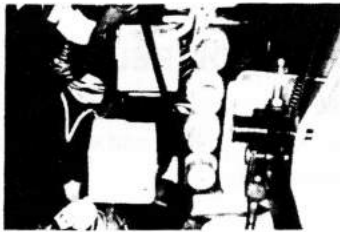

Wiper Control Relay

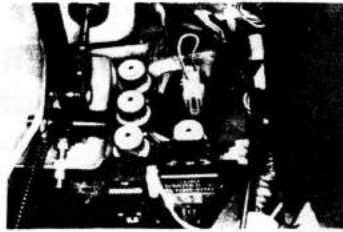

Without Relay

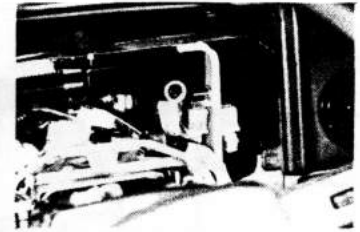

Wiper Relay

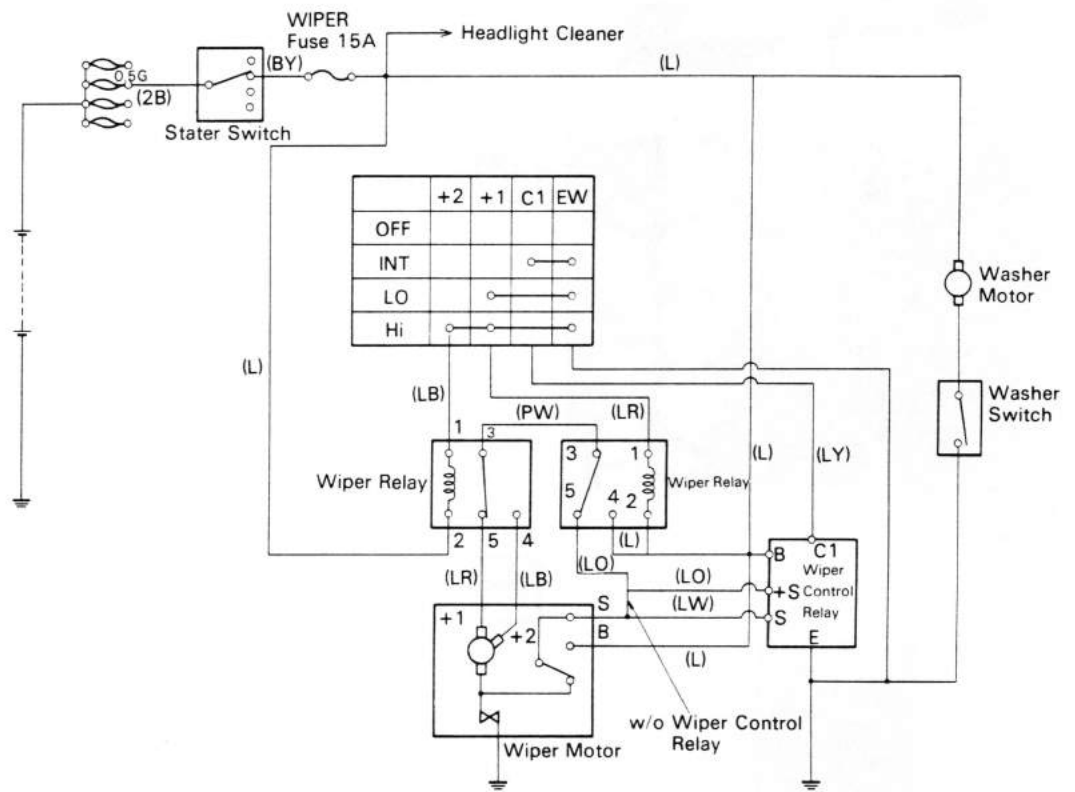

Wiring Side Terminal Position

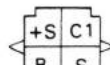

Wiper Control Relay



Wiper Motor

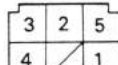

Wiper Relay (A & B)

Fig. 13-89

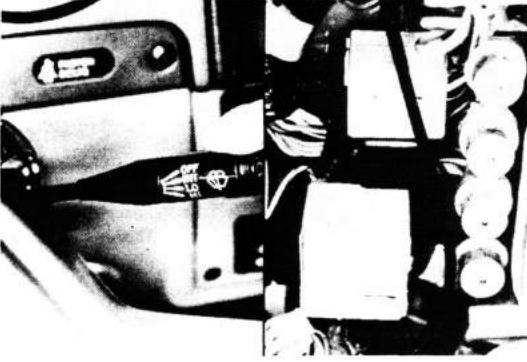
**WIPER CONTROL RELAY****INSPECTION**

1. Turn wiper switch to INT. and verify wiper control relay noise.

Fig. 13-90

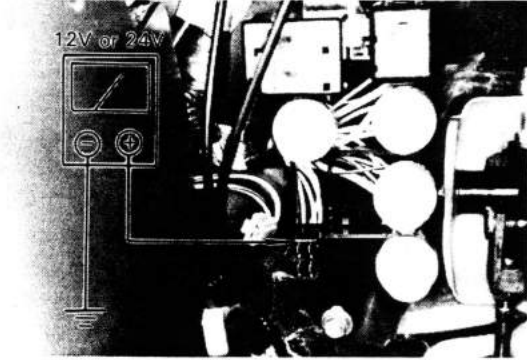

2. Battery voltage should be on terminal B.

Fig. 13-91



3. If no defects are found in the above inspection replace the wiper control relay.

– Note –

If wipers, other than the intermittent wiper, do not operate properly, repair beforehand.

Fig. 13-92

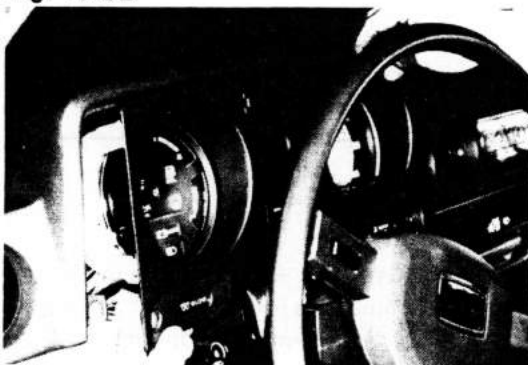

WIPER RELAY (for 24V)



Remove the combination meter.

— Note —

The relays were installed behind the combination meter.

Fig. 13-93

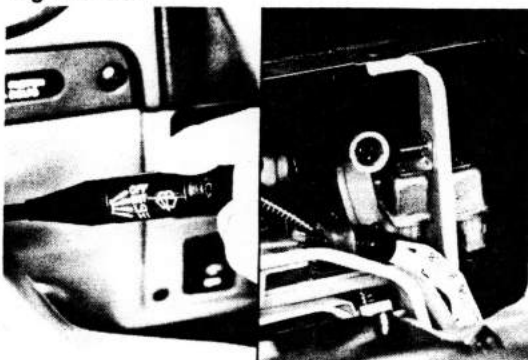

INSPECTION



1. Turn on the switch, check that there is an operating noise.

Fig. 13-94

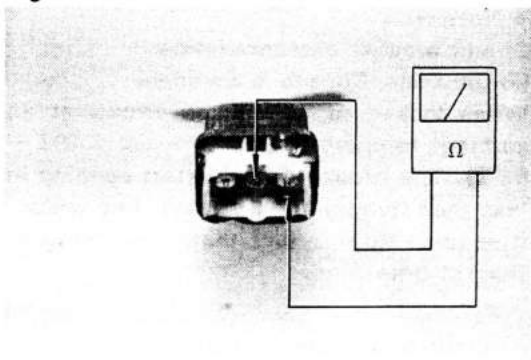

2. Check continuity between terminals.

Between Terminals	Resistance (Ω)
1 — 2	240
3 — 4	∞
3 — 5	0

Fig. 13-95

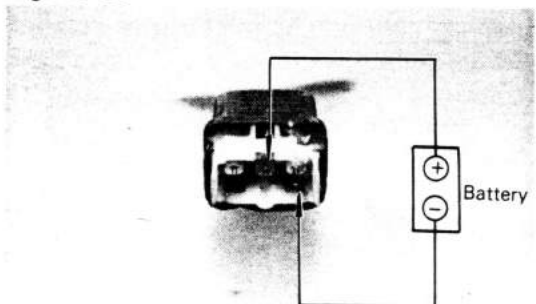

3. With terminal 1 connected to the battery (+) terminal and terminal 2 connected to the battery (-) terminal, check that there is relay operational noise.

Fig. 13-96

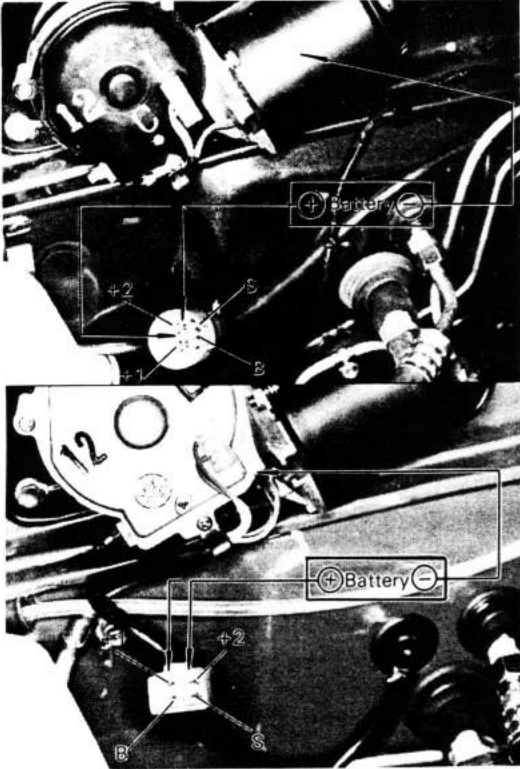
**WIPER MOTOR & LINK****INSPECTION**

With terminal +2 or +1 connected to the battery (+) terminal and motor body connected to the battery (-) terminal, confirm that the motor rotates smoothly.

Fig. 13-97

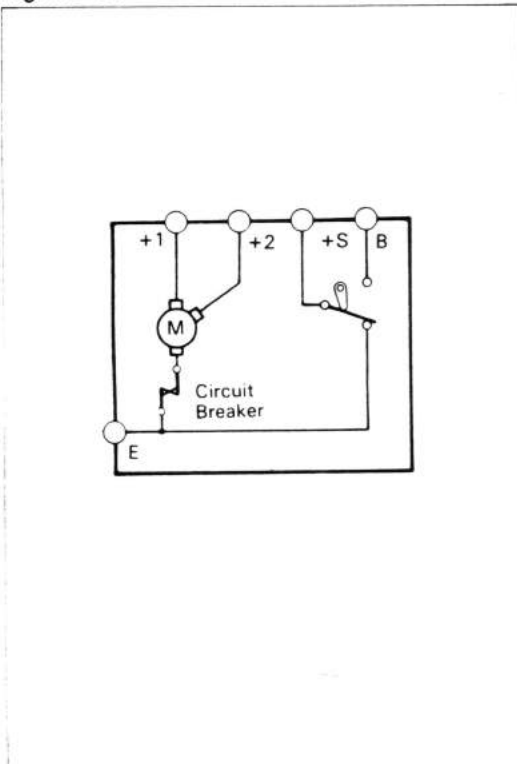

— Note —

Circuit breaker characteristics:
(Frigid Zone, Canada & Sweden)

When locked in low speed circuit at an ambient temperature of 20 – 30°C (68 – 86°F): The breaker should start opening in less than five minutes the 1st time tried.

It should return in less than three minutes the 1st time tried.

REMOVAL

Remove the parts in the numerical order shown in the figure.

Fig. 13-98

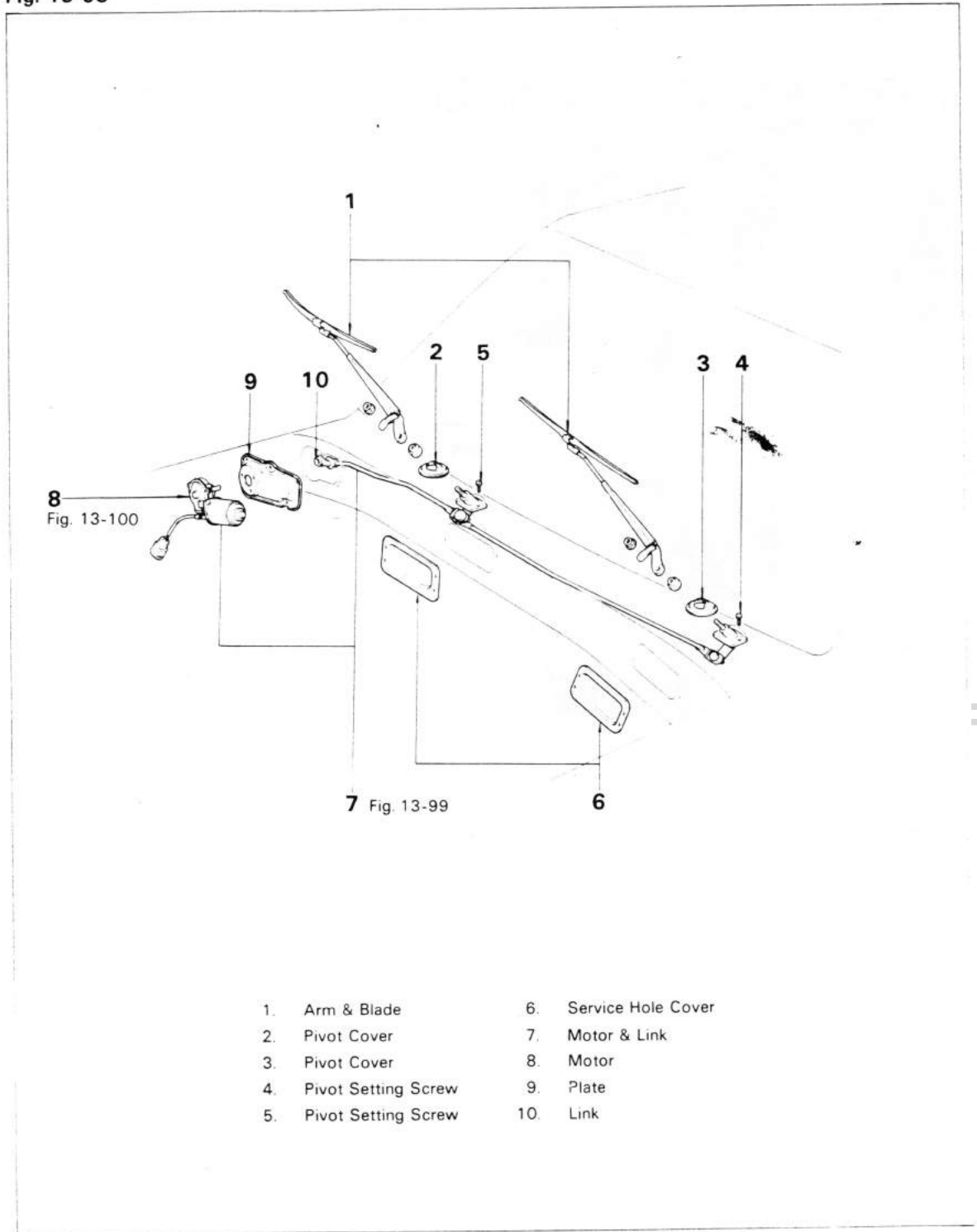

- | | |
|------------------------|-----------------------|
| 1. Arm & Blade | 6. Service Hole Cover |
| 2. Pivot Cover | 7. Motor & Link |
| 3. Pivot Cover | 8. Motor |
| 4. Pivot Setting Screw | 9. Plate |
| 5. Pivot Setting Screw | 10. Link |

Fig. 13-99



Remove the motor and link together.

Fig. 13-100



Pry the link with screwdriver and disconnect the link from the motor.

INSTALLATION

Install the parts in the numerical order shown in the figure.

Fig. 13-101

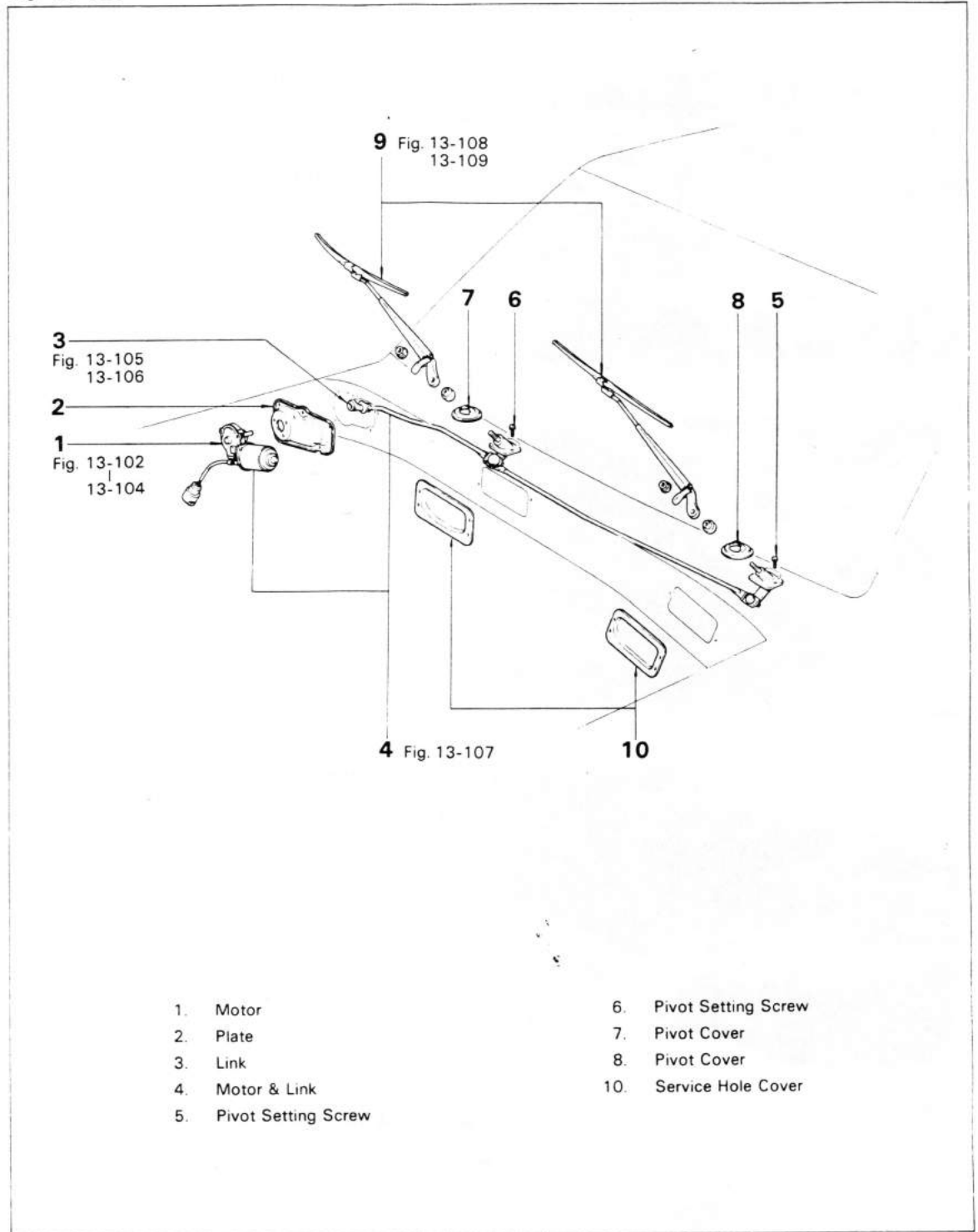

- | | |
|------------------------|------------------------|
| 1. Motor | 6. Pivot Setting Screw |
| 2. Plate | 7. Pivot Cover |
| 3. Link | 8. Pivot Cover |
| 4. Motor & Link | 10. Service Hole Cover |
| 5. Pivot Setting Screw | |

Fig. 13-102

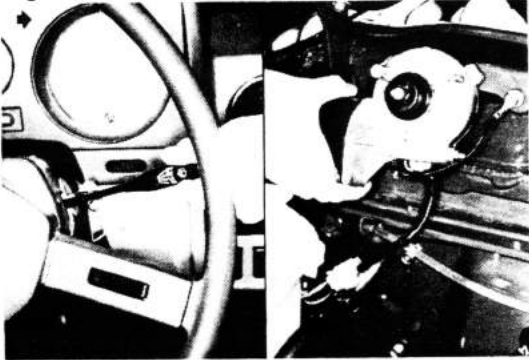

Before installing the motor, connect the motor link.

1. Temporarily connect the connector.
2. Turn on the wiper switch and stop the motor at the automatic stop position.

Fig. 13-103

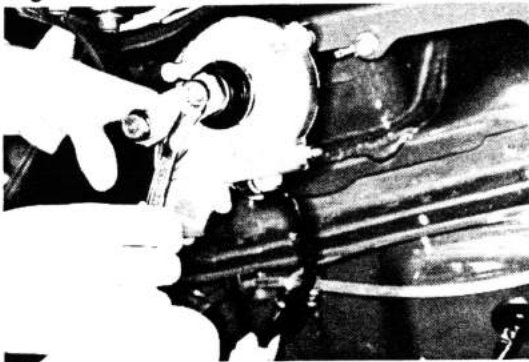

3. Install the motor arm.

Fig. 13-104

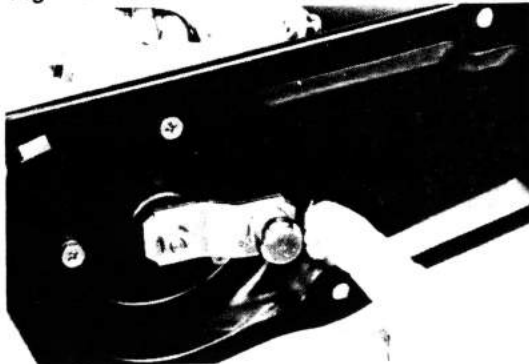

4. Install the motor link as shown in the figure.

Fig. 13-105



Coat MP grease at the joint parts.

Fig. 13-106



After connecting the motor and link, install the motor.

Fig. 13-107

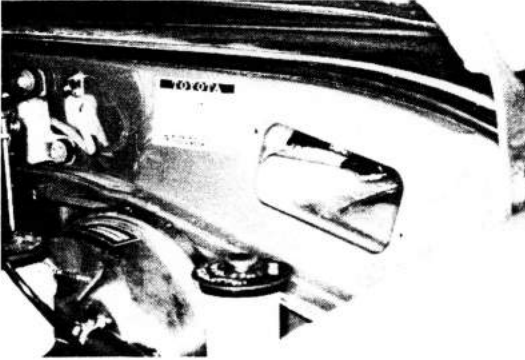

Install the link under the reinforcement.

Fig. 13-108

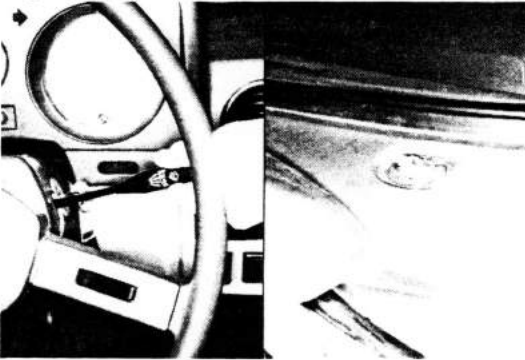

Install the wiper arm.

1. Place the wire motor in the automatic stop position.

Fig. 13-109

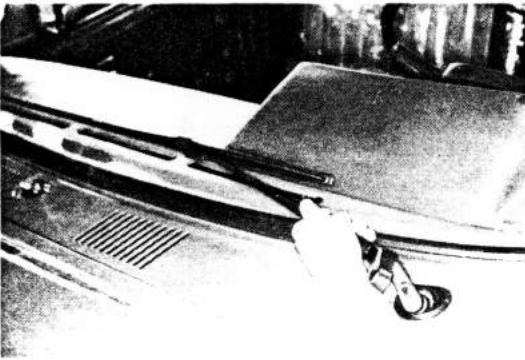

2. Install the wiper arm at the lower position.

FRONT WASHER COMPONENTS

Fig. 13-110

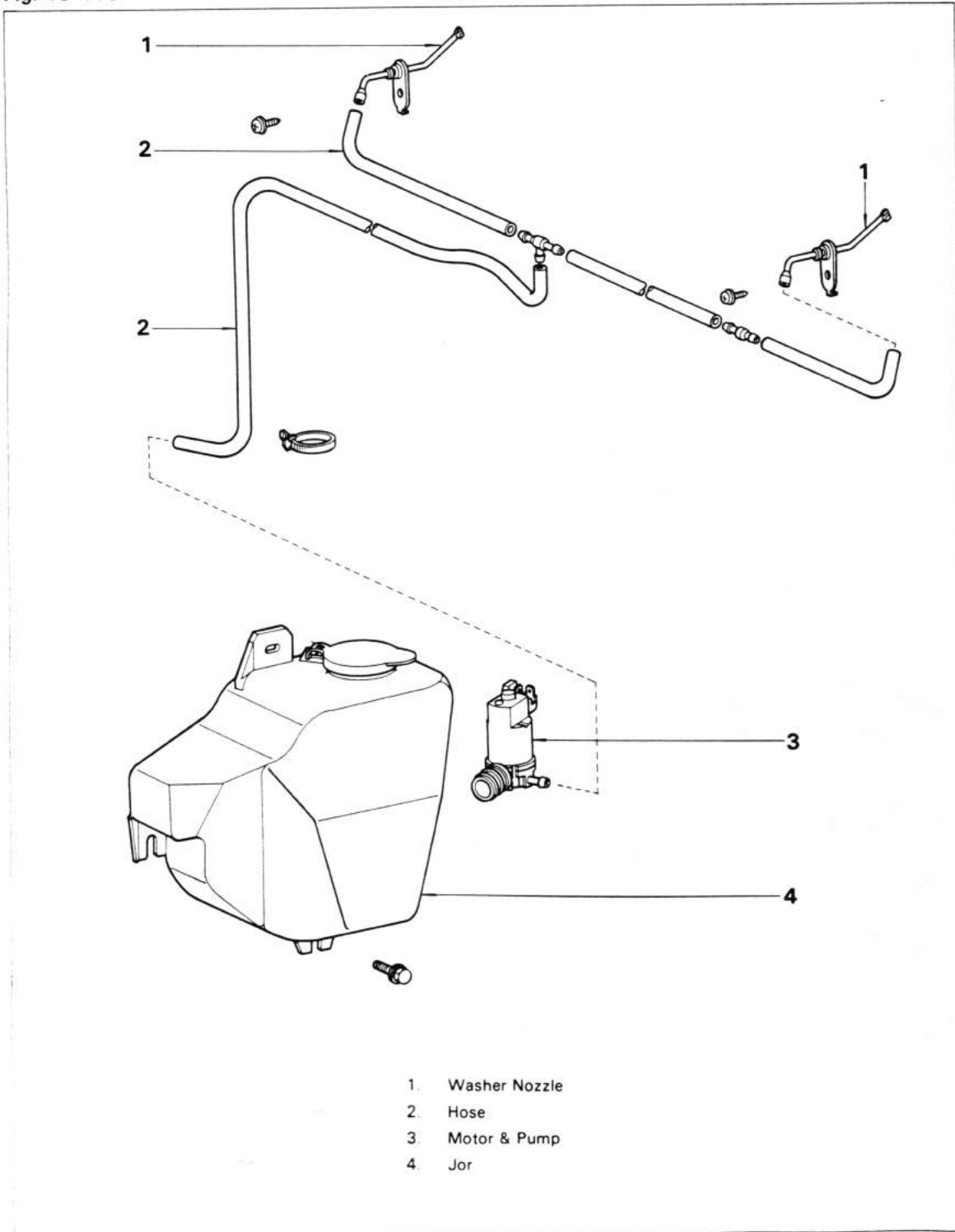

REAR WIPER & WASHER CIRCUIT DIAGRAM

Fig. 13-111

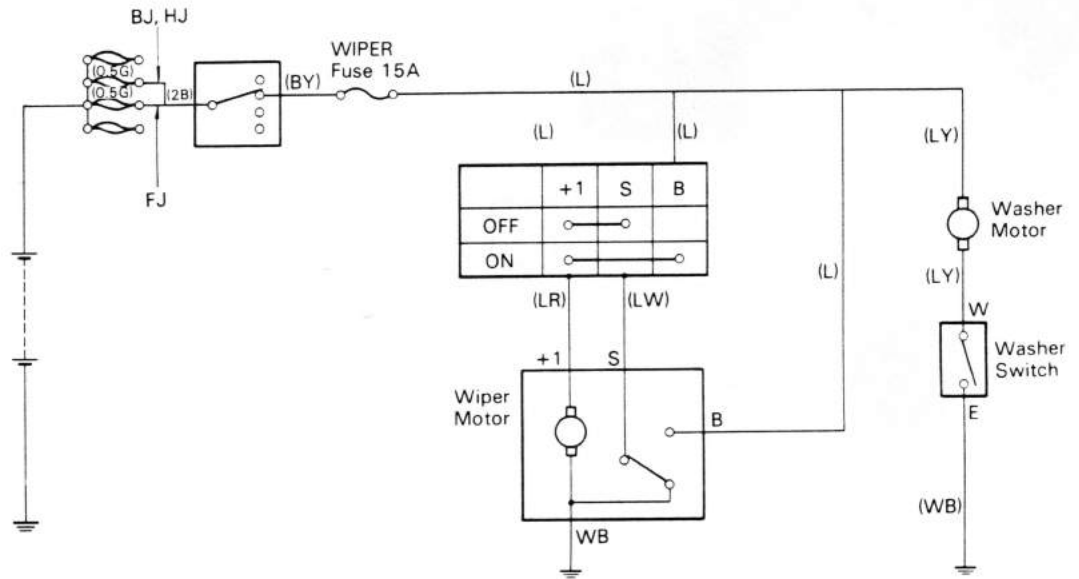

Wiring Side Terminal Position

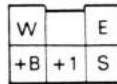

Rear Wiper Switch



Wiper Motor

cardiagn.com

Fig. 13-112



REAR WIPER SWITCH INSPECTION

1. Remove the switch.
2. Remove the center panel.
3. Disconnect the connector.

Fig. 13-113

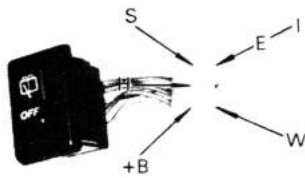

4. Check the continuity between the terminals.

		S	+1	+B	E	W
Wiper	OFF	○—○				
	ON		○—○			
Washer					○—○	

Fig. 13-114

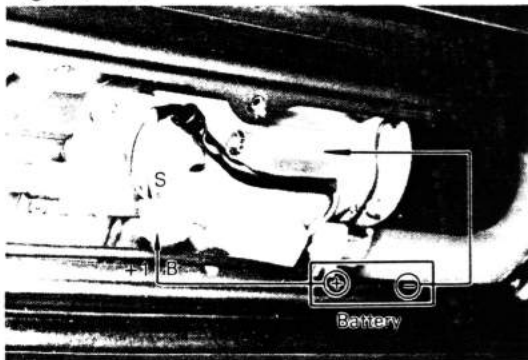

WIPER MOTOR INSPECTION

With terminal (+1) connected to the battery (+) terminal and motor body connected to the battery (-) terminal, confirm that the motor rotates smoothly.

REMOVAL

Remove the parts in the numerical order shown in the figure.

Fig. 13-115

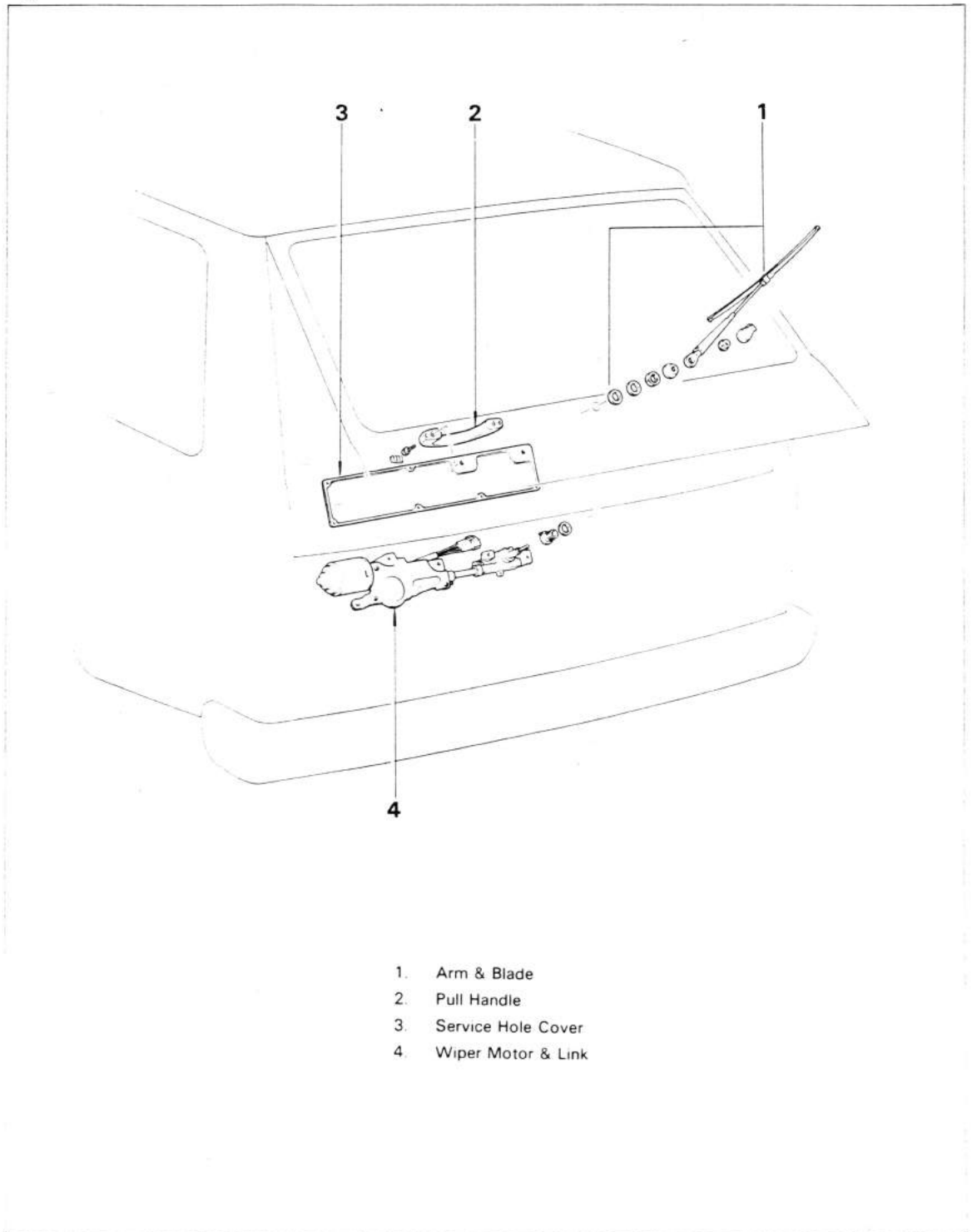

- 1. Arm & Blade
- 2. Pull Handle
- 3. Service Hole Cover
- 4. Wiper Motor & Link

INSTALLATION

Install the parts in the numerical order shown in the figure.

Fig. 13-116

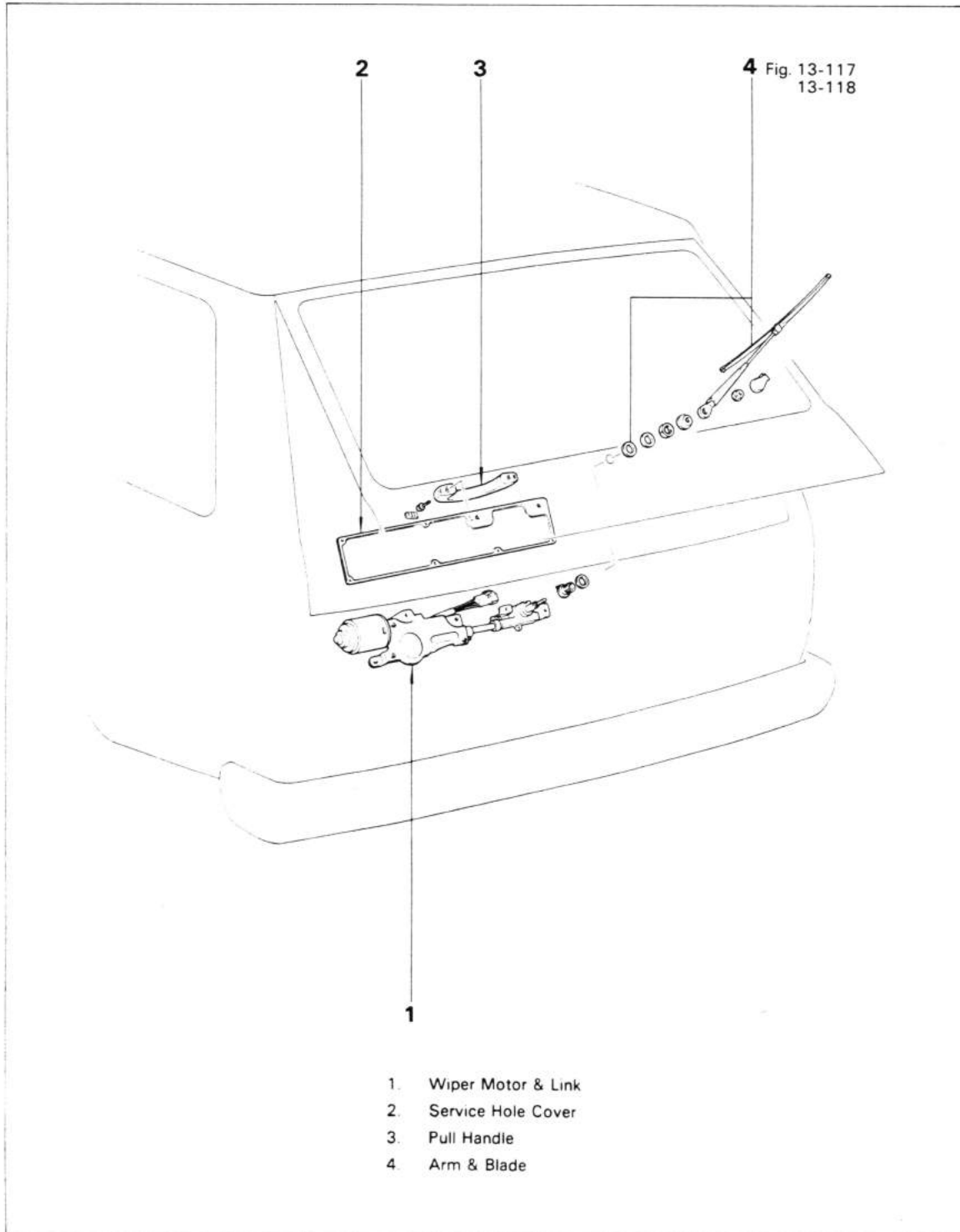
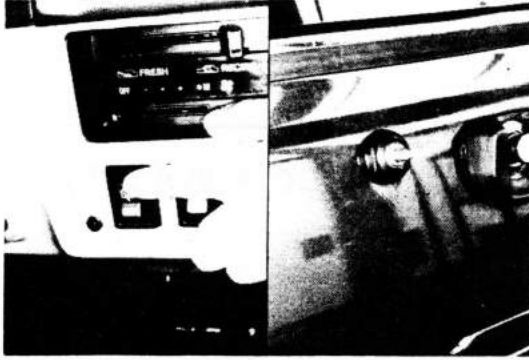
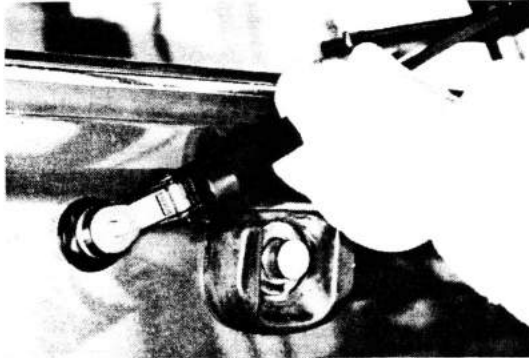

Fig. 13-117



Before installing the wiper arm, place the wiper motor in the automatic stop position.

Fig. 13-118



Install the wiper arm with lower position.

REAR WINDOW WASHER COMPONENTS

Fig. 13-119

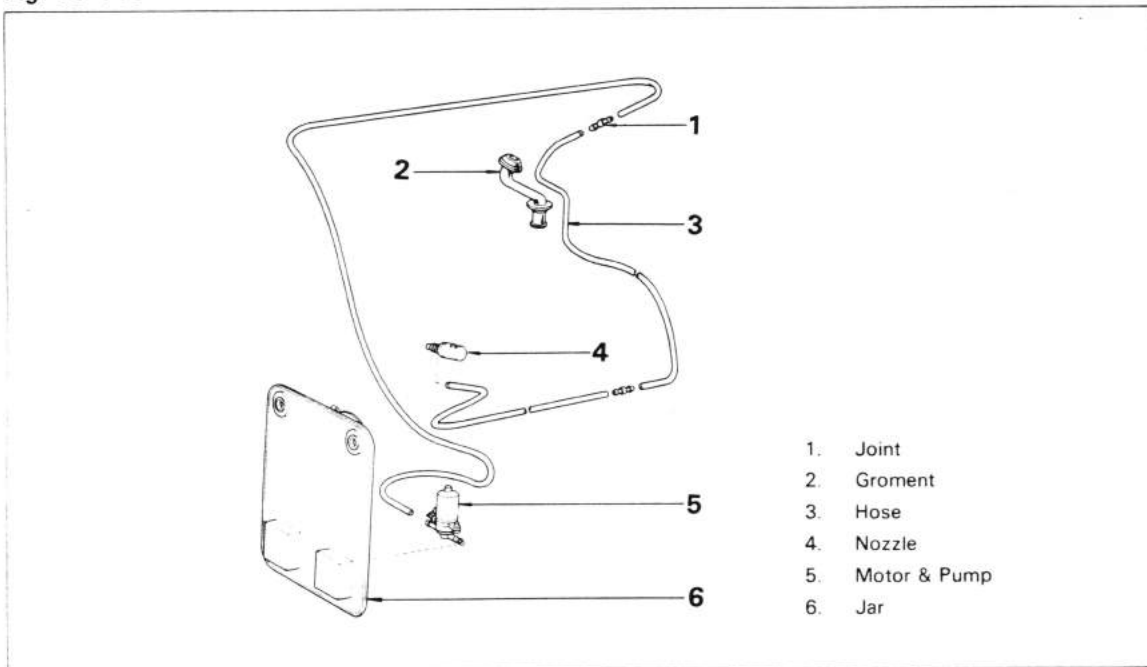
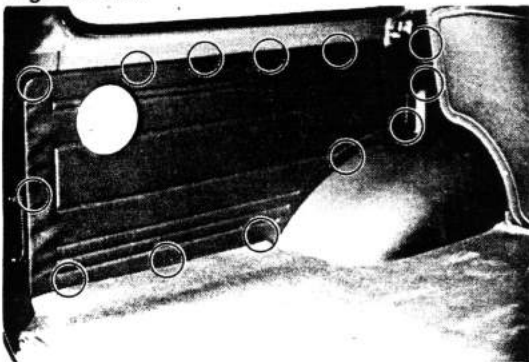

Fig. 13-120



REMOVAL

The clips are located as shown in the figure.

— Note —

The washer tank is installed behind the trim.

Fig. 13-121

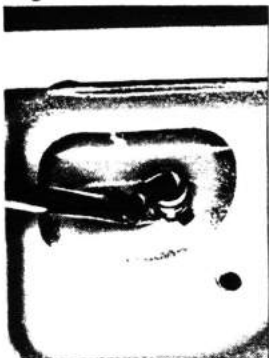

Push up one lock clip a screwdriver when remove the nozzle.

HEADLIGHT CLEANER COMPONENTS

Fig. 13-122

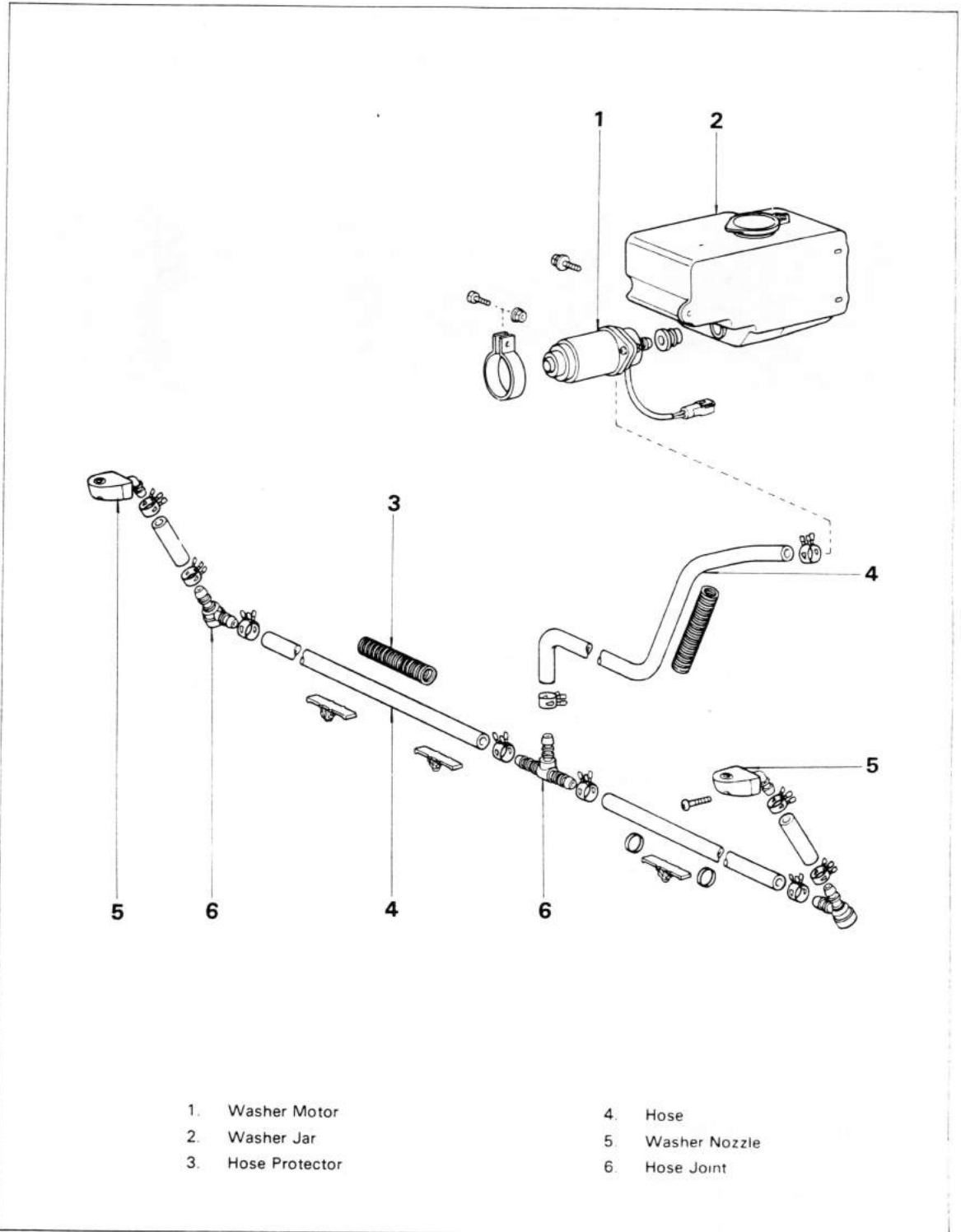

- 1. Washer Motor
- 2. Washer Jar
- 3. Hose Protector

- 4. Hose
- 5. Washer Nozzle
- 6. Hose Joint

cardiagn.com

CIRCUIT DIAGRAM

Fig. 13-123

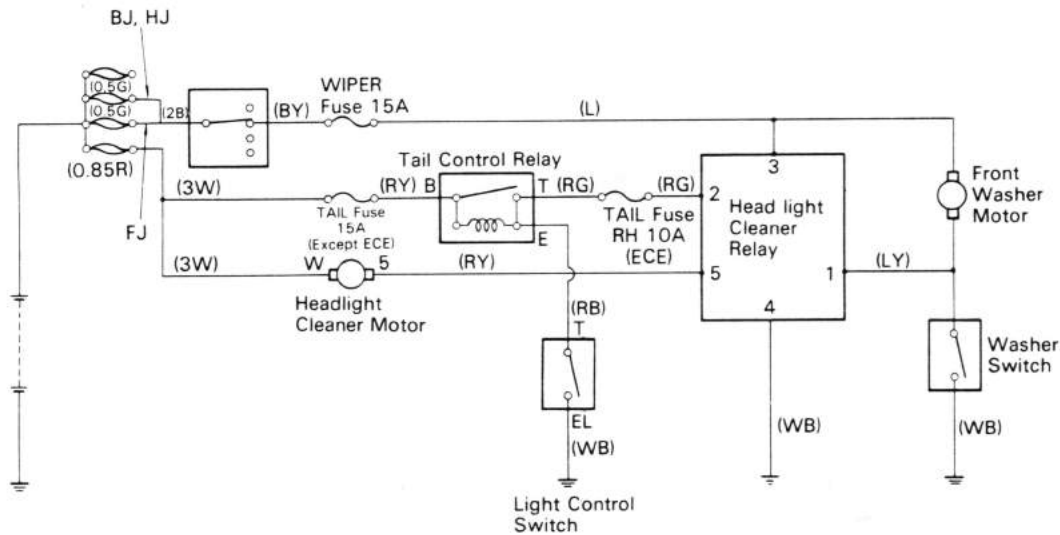

Wiring Side Terminal Position

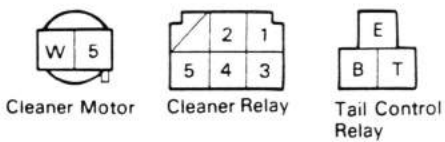

cardiagn.com

Fig. 13-124

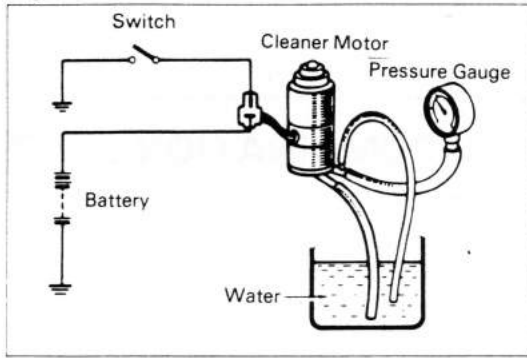

INSPECTION



Mount a pressure gauge to the outlet union, and check the motor discharge pressure.

Discharge pressure:
1.8 kg/cm² Over
(26 psi)

Fig. 13-125

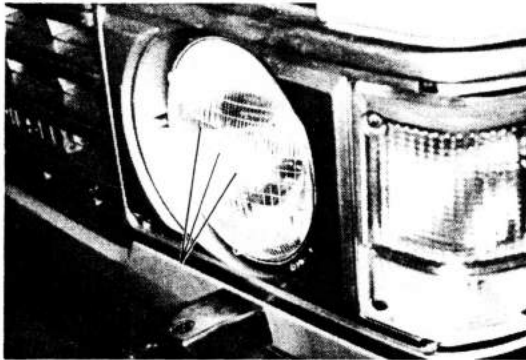

— Note —

If one nozzle starts spraying extremely faster than the other, replace the nozzle assembly.

Fig. 13-126

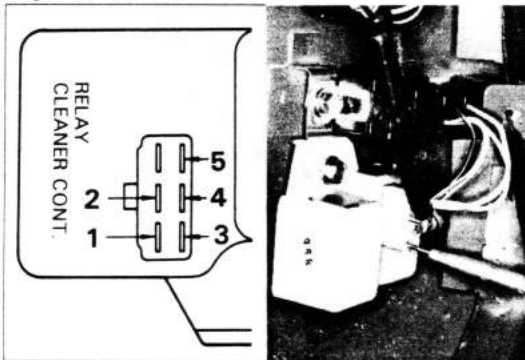

Battery voltage should be on terminals 3, 2 and 5.

Fig. 13-127

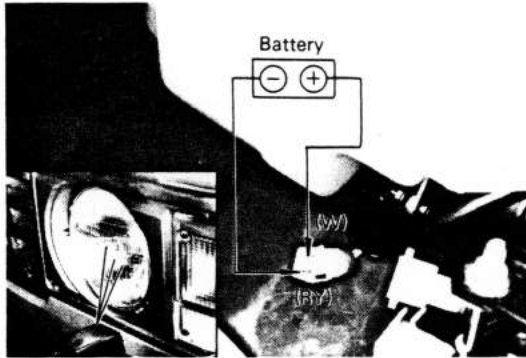

CLEANER MOTOR



When connecting the battery voltage to the connector, the water is injected from the nozzle.

SPEEDOMETER & COMBINATION METER

REMOVAL

Remove the parts in the numerical order shown in the figure.

Fig. 13-128

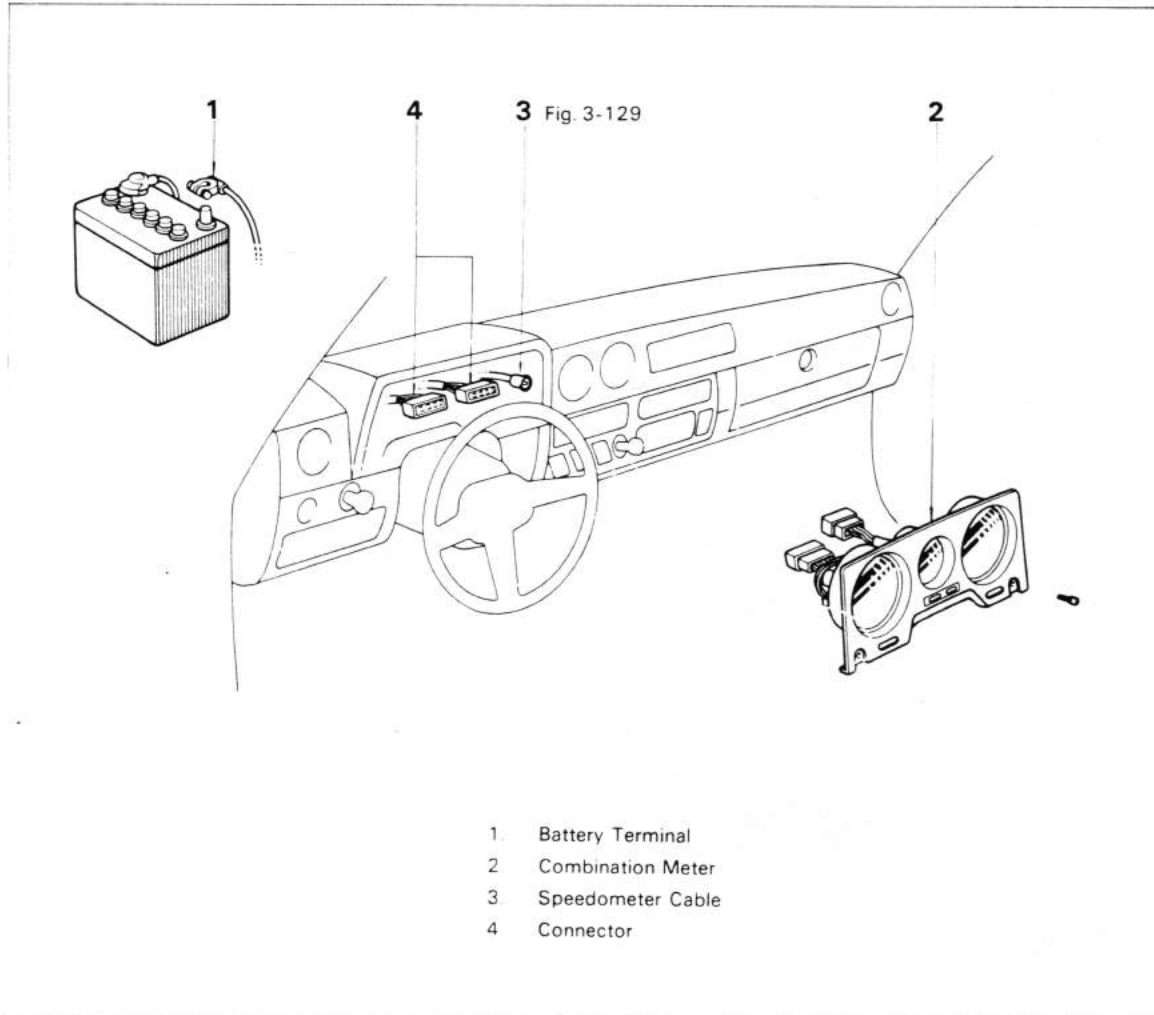
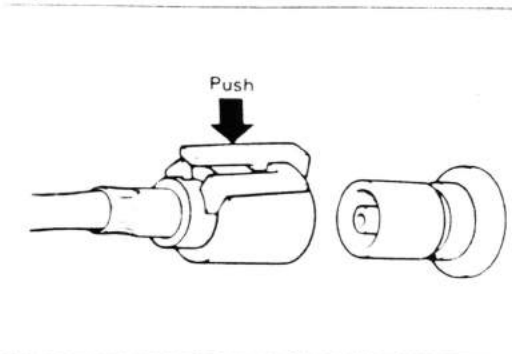

Fig. 13-129



Before removing the combination meter, pull out the cable while pushing the lock lever.

INSPECTION

Fig. 13-130

12V

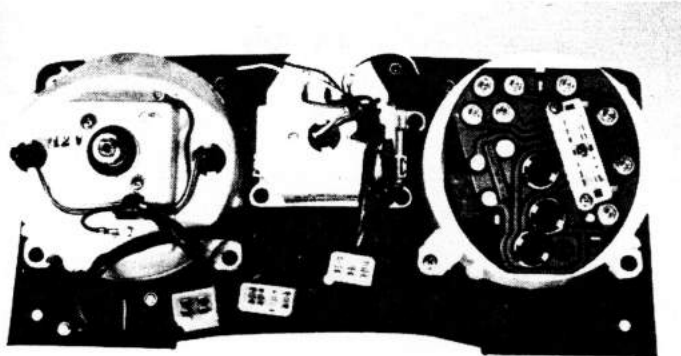

24V

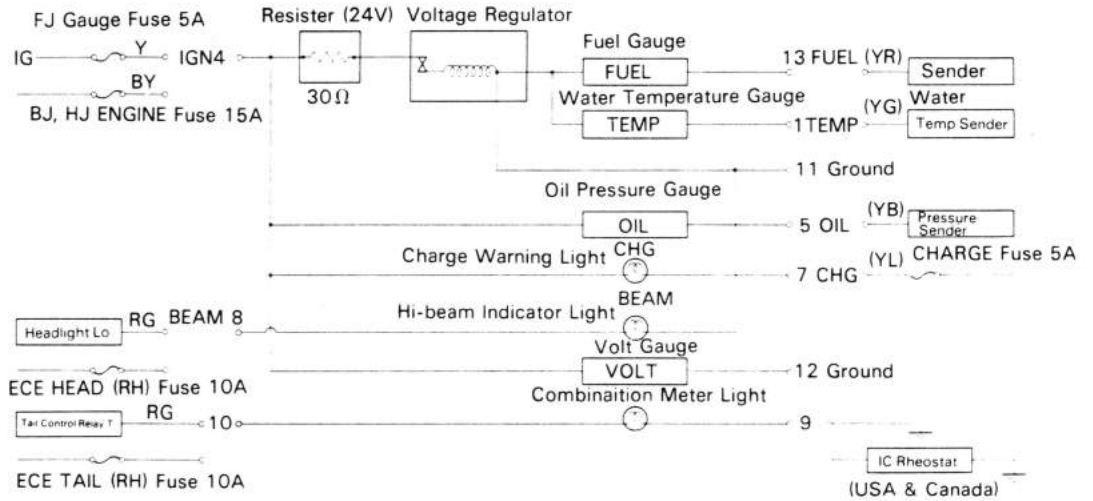
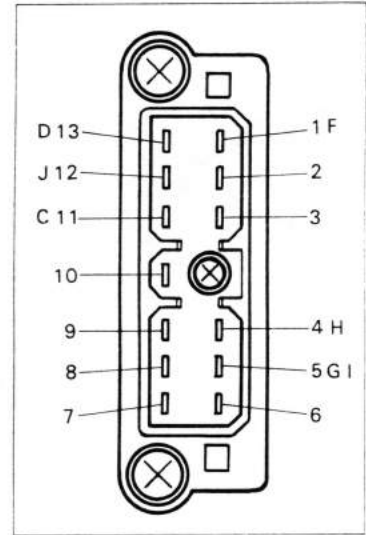
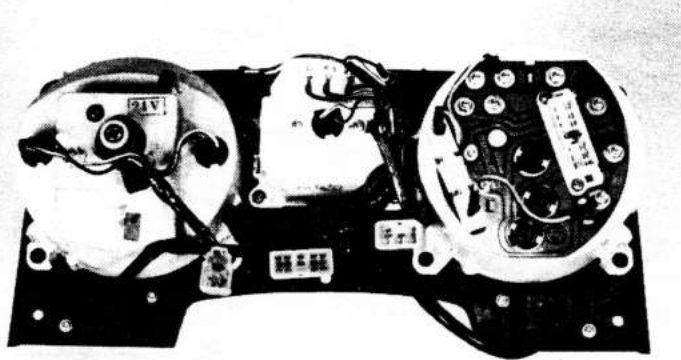

INSTALLATION

Install the parts in the numerical order shown in the figure.

Fig. 12-131

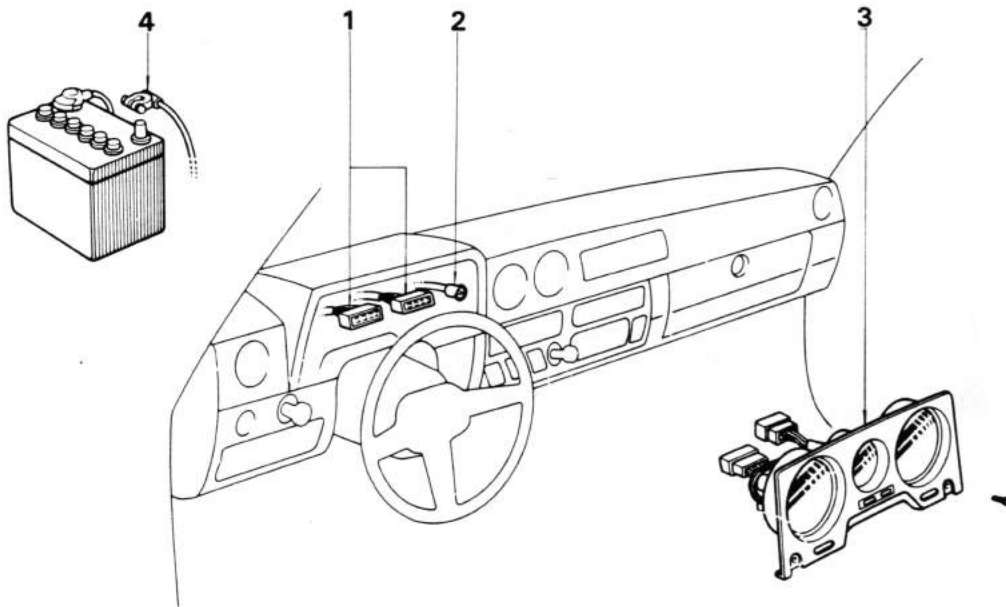

1. Connector
2. Speedometer Cable
3. Combination Meter
4. Battery Terminal

Fig. 13-132

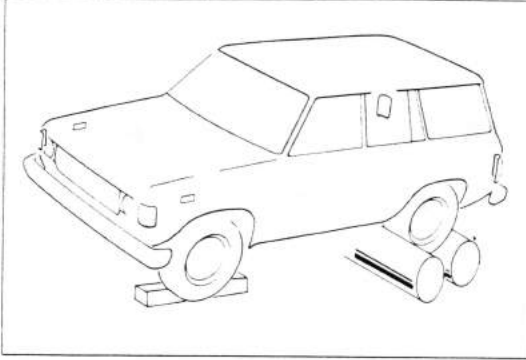

SPEEDOMETER

ON-VEHICLE INSPECTION

Using a speedometer tester, inspect the meter for indicating error, pointer vibration, abnormal noise and the operation of the odometer.

— Note —

It must be noted that tire wear and tire over-and under-inflation will contribute toward indication error, and that pointer vibration is often caused by a loose cable.

Fig. 13-133

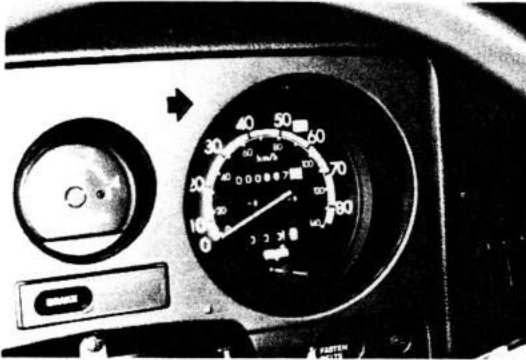

Speedometer allowable error

Std. indication (km/h)	Allowable error (km/h)
20	18 — 23
40	40 — 44
60	60 — 64.5
80	80 — 85
100	100 — 105
120	121 — 126.5
140	140 — 146

ENGINE TACHOMETER CURCUIT DIAGRAM

Fig. 13-134

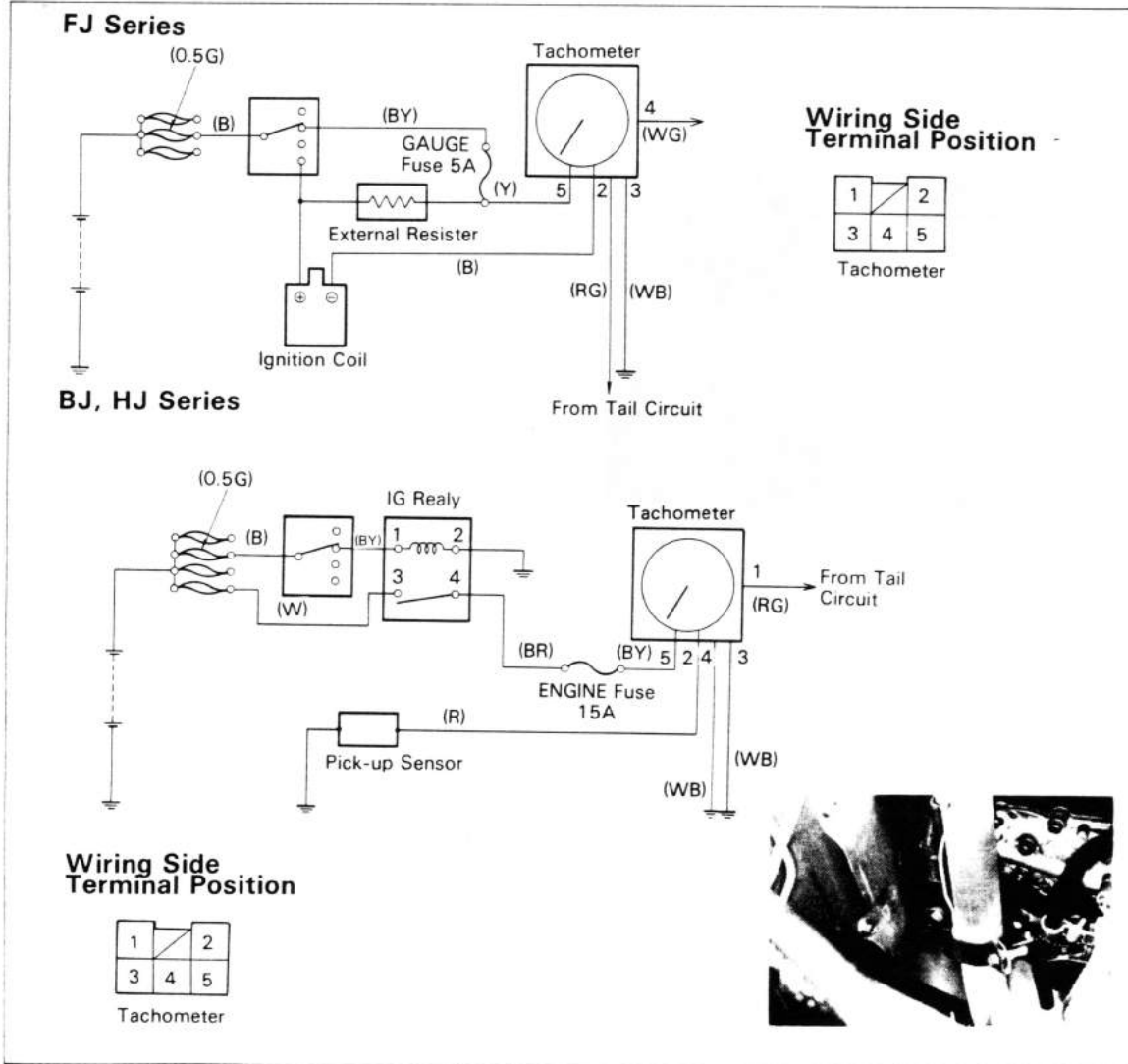
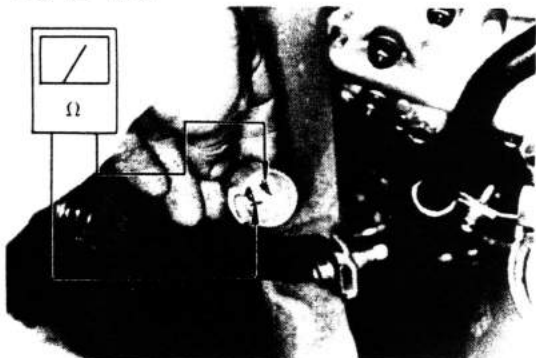

Fig. 13-135



INSPECTION

Pick-up Sensor (for 3B & 2H)

Check the resistance between the terminals.

Resistance: About 500Ω

Fig. 13-136

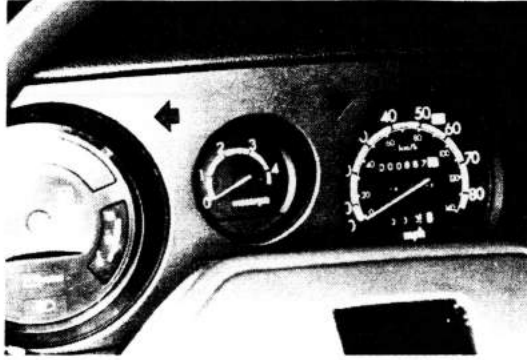

1. Connect a tune-up test tachometer, and start the engine.
2. Compare the tester and tachometer indications, and if the error is too great, replace the tachometer.

— Caution —

1. Do not reverse battery connections as this tachometer is intended only for use in (-) ground vehicles. A reversed connection could damage the transistors and diodes contained inside.
2. In removing or installing the tachometer, be careful not to drop it or subject it to heavy shocks.

Tachometer allowable range

rpm	1,000	2,000	3,000
20°C 13V	± 100	± 125	± 150

COMPONENTS

Fig. 13-137

BJ, HJ Series Pick-up Sensor

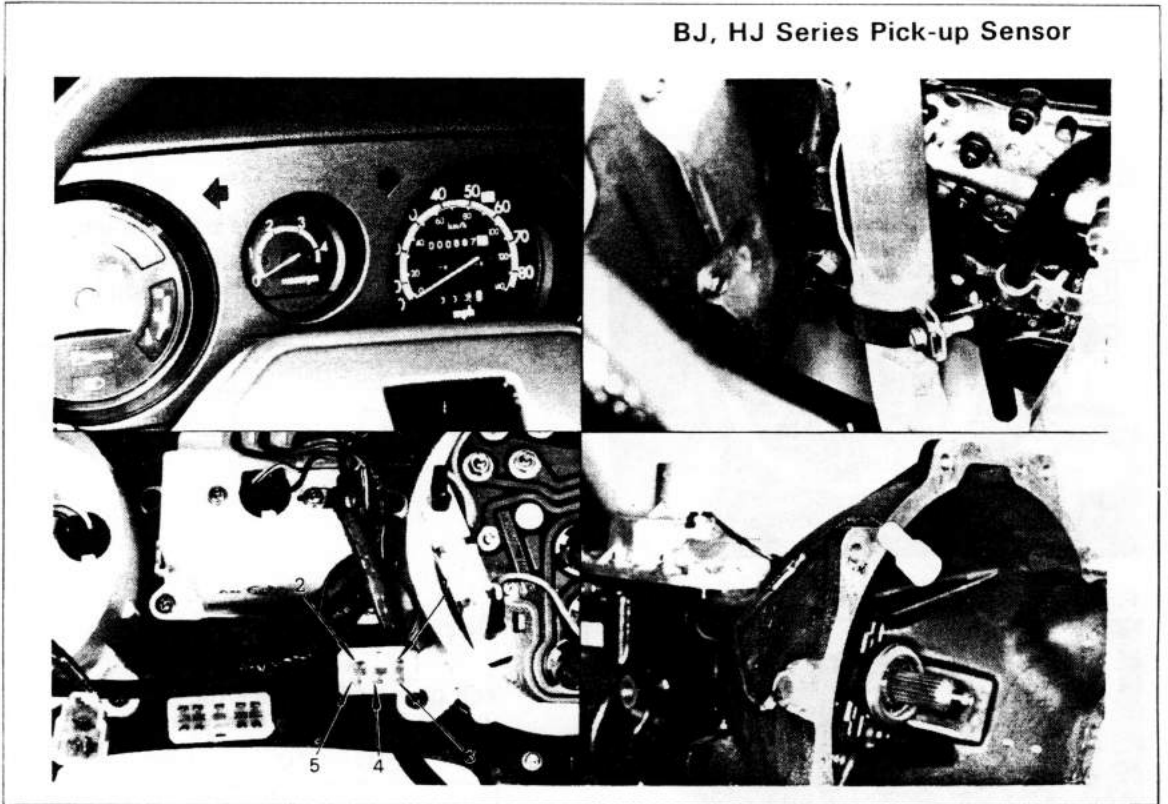

cardiagn.com

VOLTAGE METER CIRCUIT DIAGRAM

Fig. 13-138

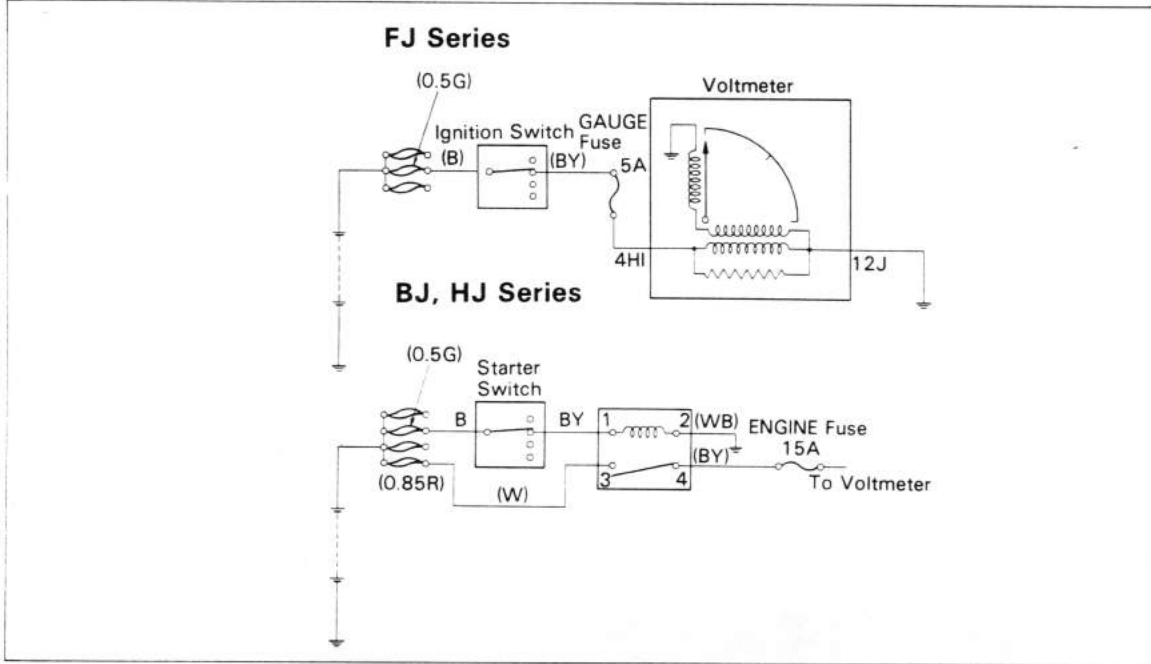
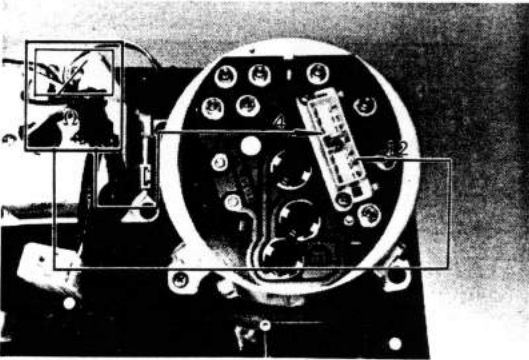

Fig. 13-139



INSPECTION



Measure the resistance between terminals. If each resistance value as shown in the table below, the relay is in good condition.

Between terminals	Resistance (Ω)
J - I	approx. 650

Fig. 13-140



Check the indicator value.

Volt gauge allowable error
W/12V Battery

V	10	12	14
Error	+ 0.4 - 0.6	\pm 0.3	+ 0.6 - 0.4

W/24V Battery

V	20	24	28
Error	+ 0.8 - 1.2	\pm 0.6	+ 1.2 - 0.8

FUEL GAUGE CIRCUIT DIAGRAM

Fig. 13-141

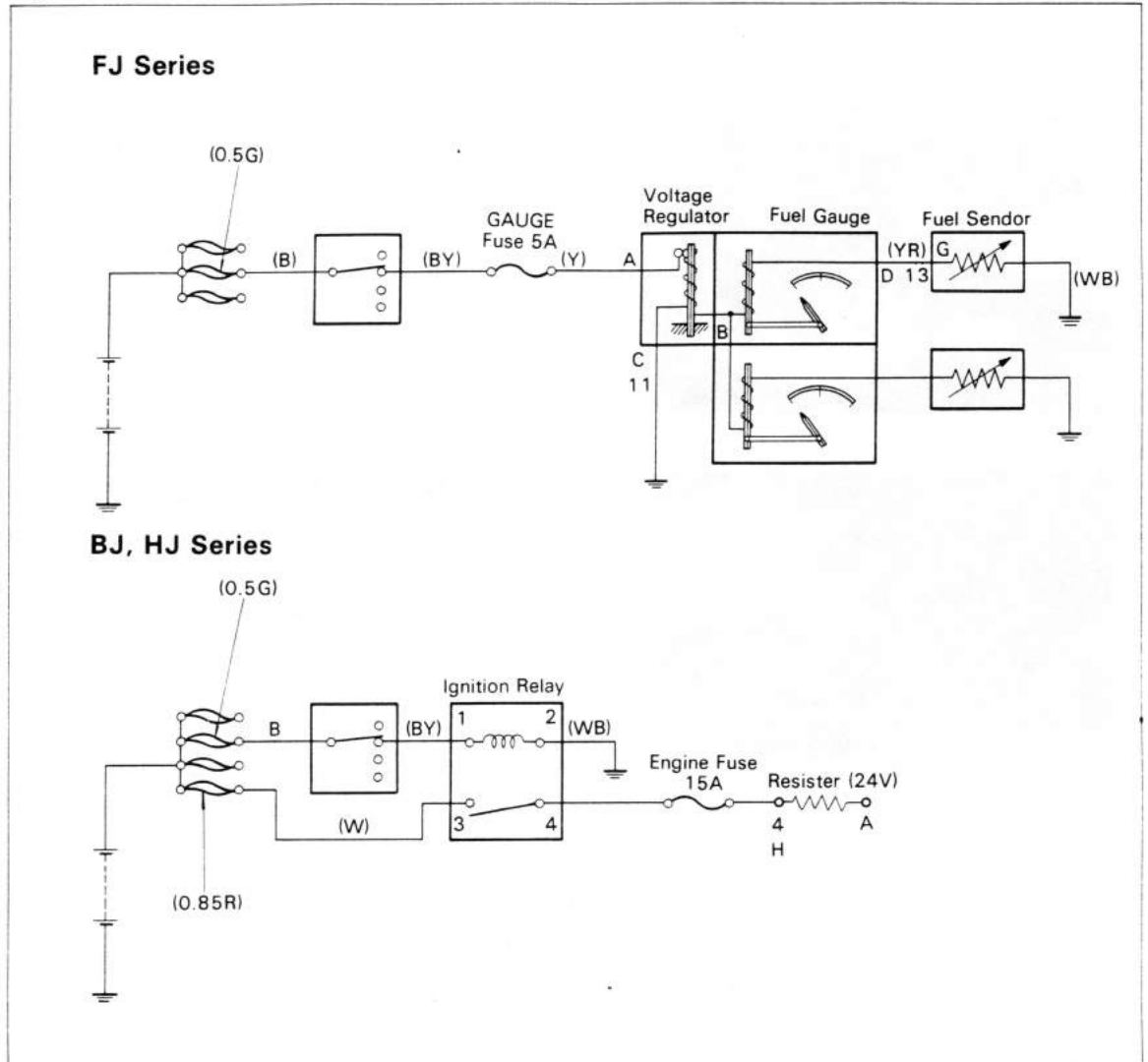
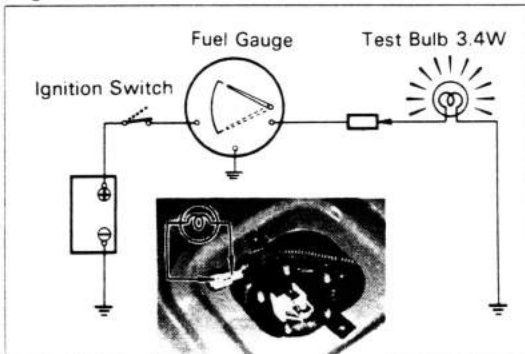

Fig. 13-142



ON-VEHICLE INSPECTION



1. Pull the connector out of the fuel sender gauge and ground it through a 3.4W bulb.
2. After the ignition switch is turned ON, the bulb should start flashing with in several seconds, and the gauge needle should vibrate.

Fig. 13-143

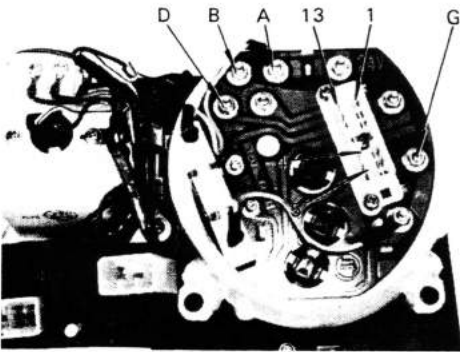

Fig. 13-144

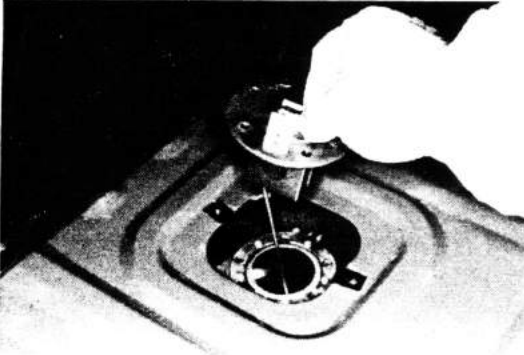
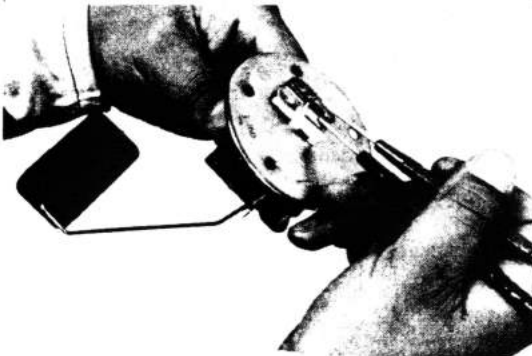
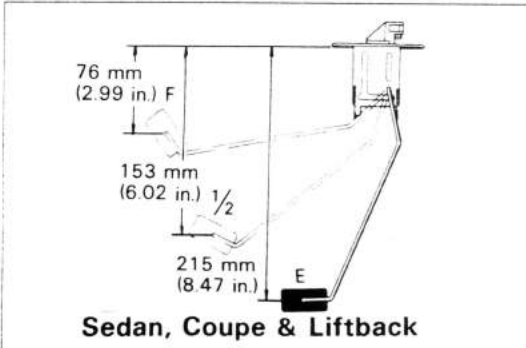

Fig. 13-145

**INSPECTION**

1. Measure the resistance between terminals B and D.

Resistance: STD 25 Ω

2. When the ignition switch is turned ON with a connector connected to the control panel, voltage should be applied to the terminal A.
3. Under the above condition, 2-7V of current should be applied to terminals B and D.

(A regulator is built into the fuel receiver gauge.)

**FUEL SENDER GAUGE****REMOVAL**

Remove the following parts.

1. Rear floor carpet
2. Rear floor wire harness protector
3. Connector
4. Fuel sender gauge

INSPECTION

Measure the resistance between the terminal and gauge body.

If the resistance values correspond to the residual amounts of fuel as shown in the table below, the gauge is in good condition.

Float position	Resistance (Ω)
F	17 ± 2
$\frac{1}{2}$	40 ± 4
E	120 ± 6

WATER TEMPERATURE GAUGE CIRCUIT DIAGRAM

Fig. 13-146

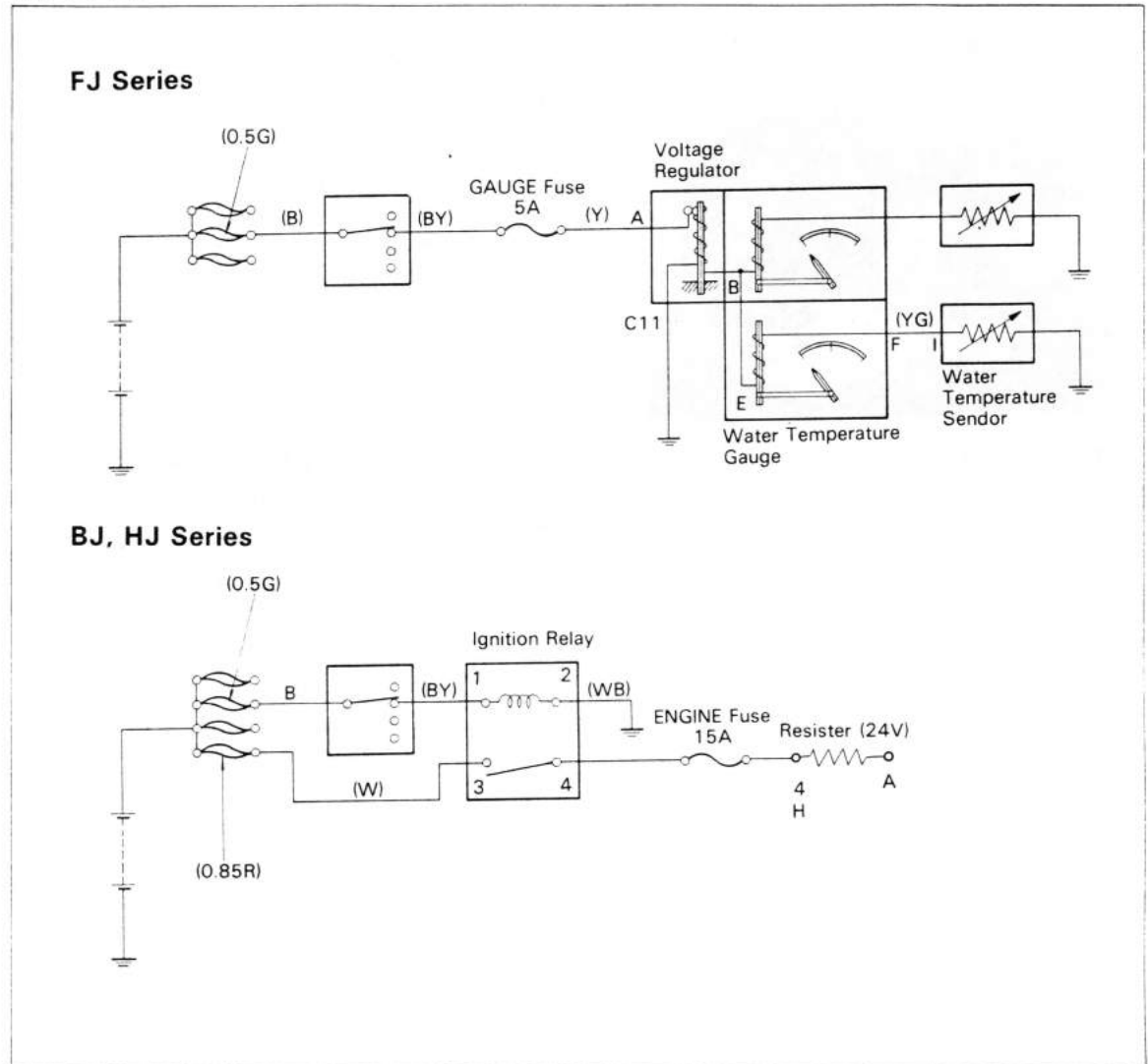
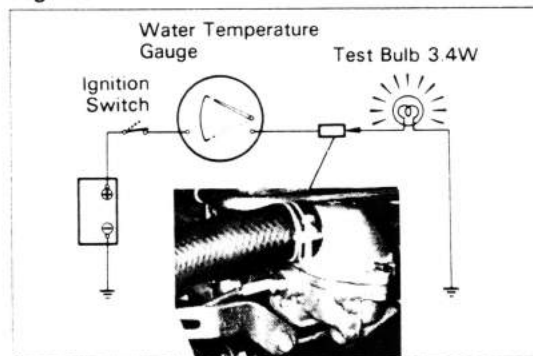

Fig. 13-147



WATER TEMPERATURE RECEIVER GAUGE ON-VEHICLE INSPECTION

1. Pull the connector out of the water temperature sender gauge and ground through a 3.4W bulb.
2. When the ignition switch is turned ON, the bulb should start flashing with in several seconds, and the gauge needle should vibrate.

cardiagn.com

Fig. 13-148

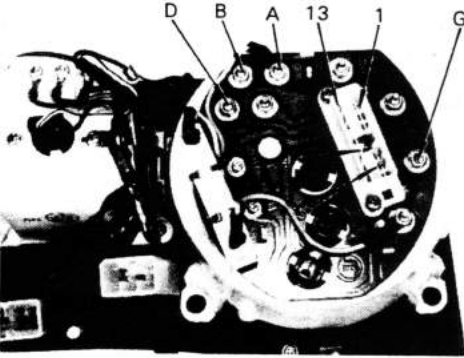
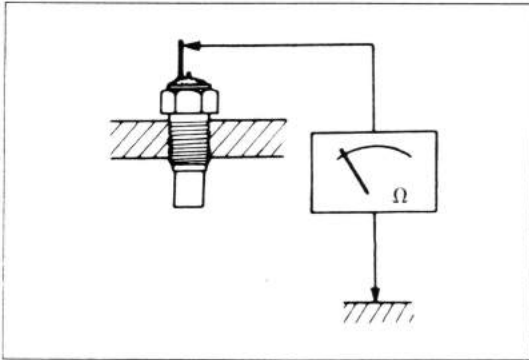

Fig. 13-149



INSPECTION (Bimetal Type)

1. Measure the resistance between terminals E and F.

Resistance: STD 25 Ω

2. When the ignition switch is turned ON with a connector connected to the control panel under the above condition, 2 – 7 V current should be applied to the terminal A.
(A regulator is built into the fuel receiver gauge.)



WATER TEMPERATURE SENDER GAUGE

INSPECTION

When resistance between the terminal and ground is measured with a circuit tester, the resistance values should correspond to the water temperatures shown in the table below.

Water temperature °C (°F)	Resistance (Ω)
50 (122)	226
115 (239)	26

OIL PRESSURE GAUGE CIRCUIT DIAGRAM

Fig. 13-150

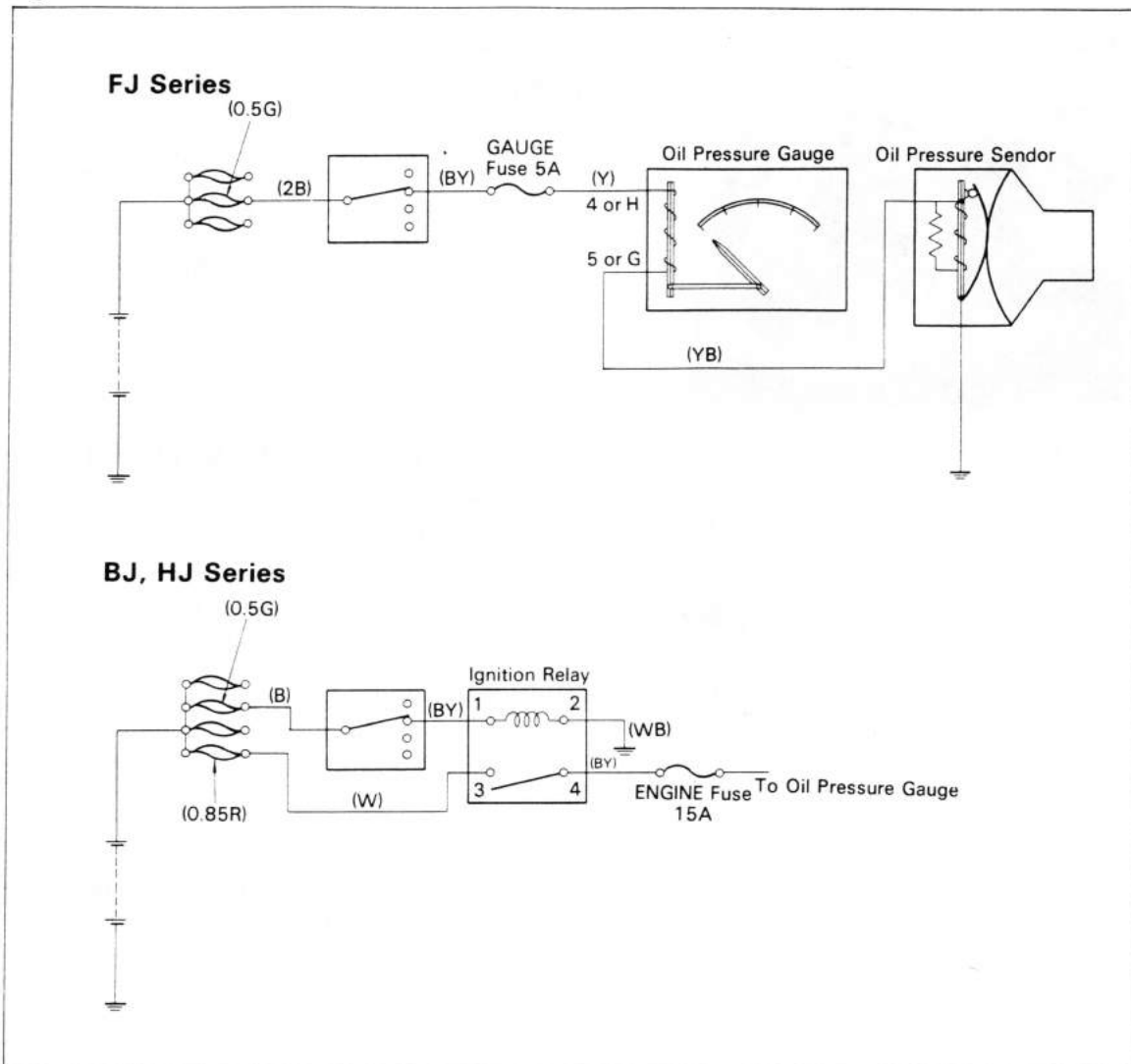
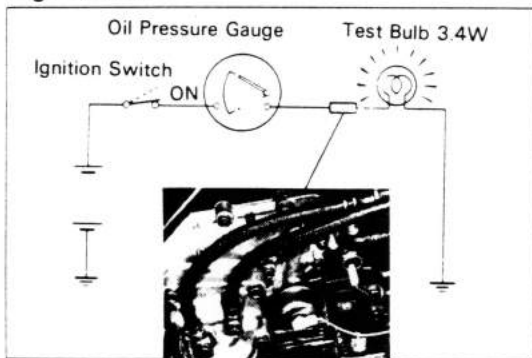

Fig. 13-151



OIL PRESSURE RECEIVER GAUGE

ON-VEHICLE INSPECTION

1. Pull the connector out of the oil pressure sender gauge and ground it through a 3.4W bulb.
2. After the ignition switch is turned ON, the bulb should light up and the gauge needle should deflect.

Fig. 13-152

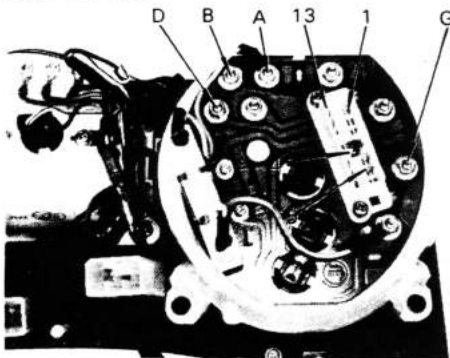
**INSPECTION**

1. Measure the resistance between terminals 4 and 5.
2. When the ignition switch is turned ON with a connector connected to the control panel, voltage should be applied to terminal G.

Resistance: 65 Ω

Fig. 13-153

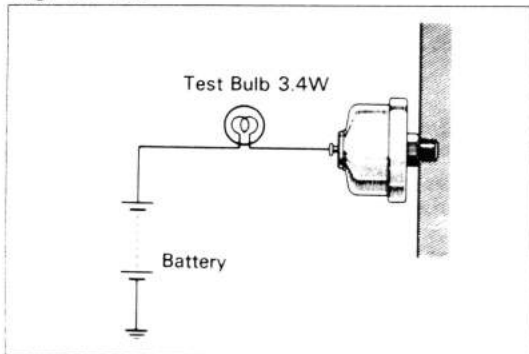
**OIL PRESSURE SENDER GAUGE****INSPECTION**

Pull out the connector from the sender, and apply battery voltage to the sender terminal through a 3.4W bulb. The bulb should not light when the engine is stopped, and should flash when the engine is running. The number of flashes should also vary with the engine speed.

— Note —

Even when the engine is stopped, the bulb may light for an instant when the battery voltage is applied, but this is normal.

BRAKE WARNING SYSTEM CIRCUIT DIAGRAM

Fig. 13-154

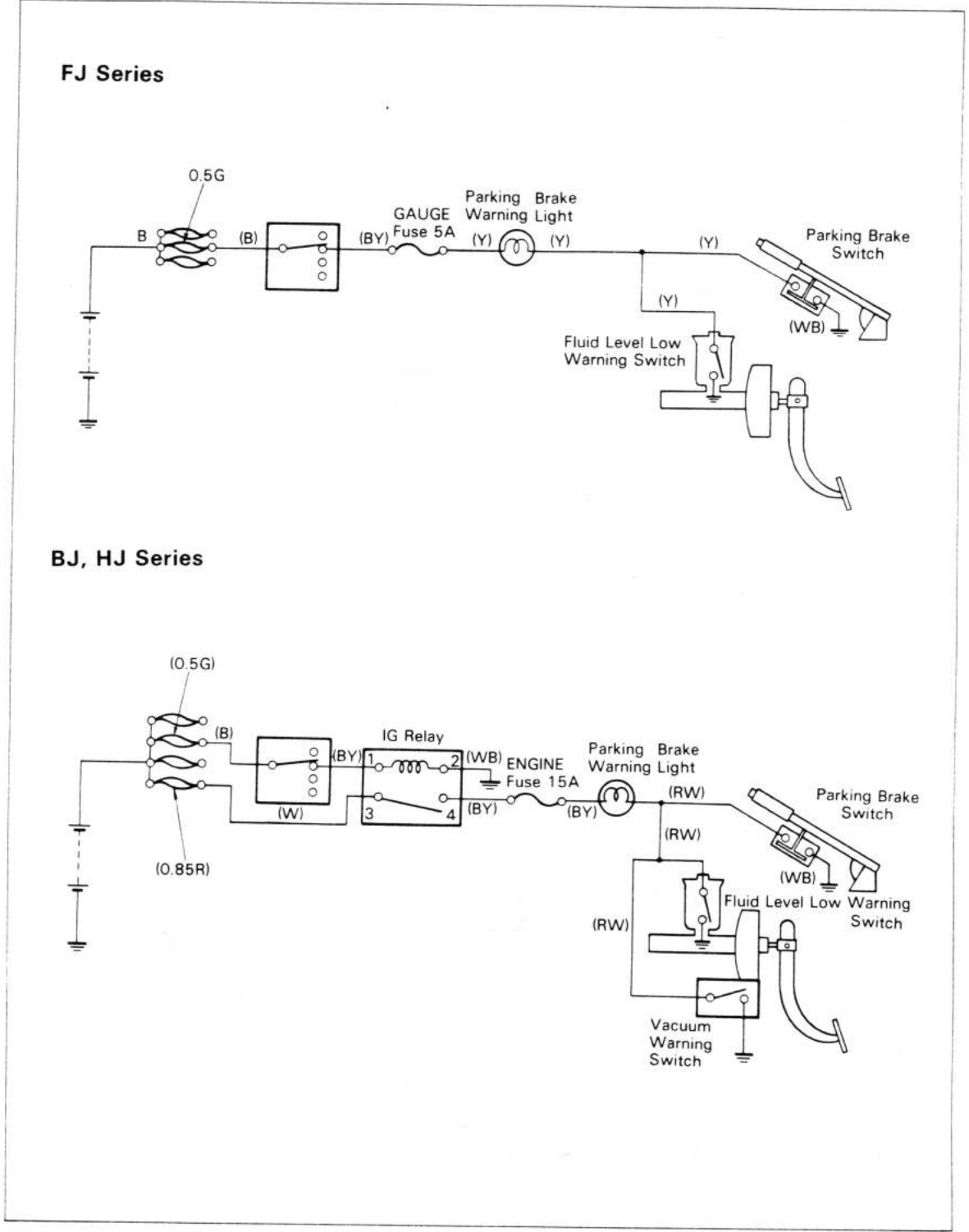

cardiagn.com

Fig. 13-155

FJ Series (ARL)

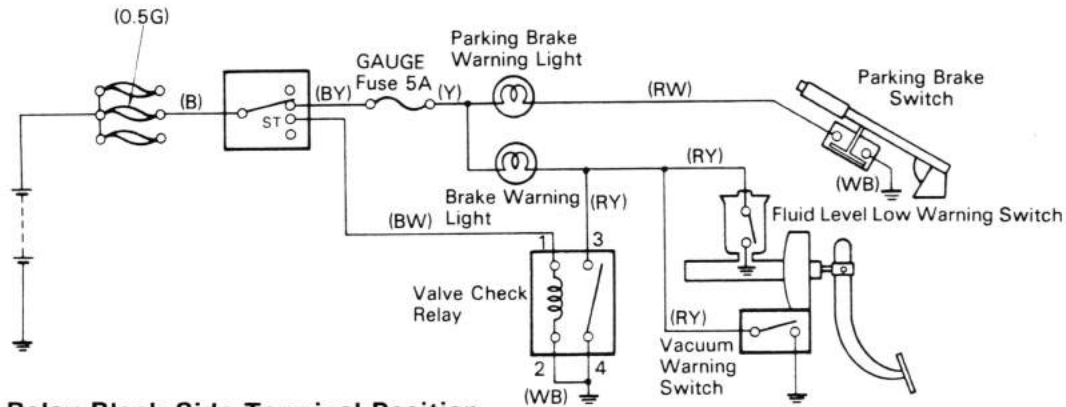

Relay Block Side Terminal Position

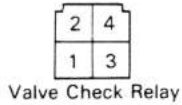

HJ Series (ARL)

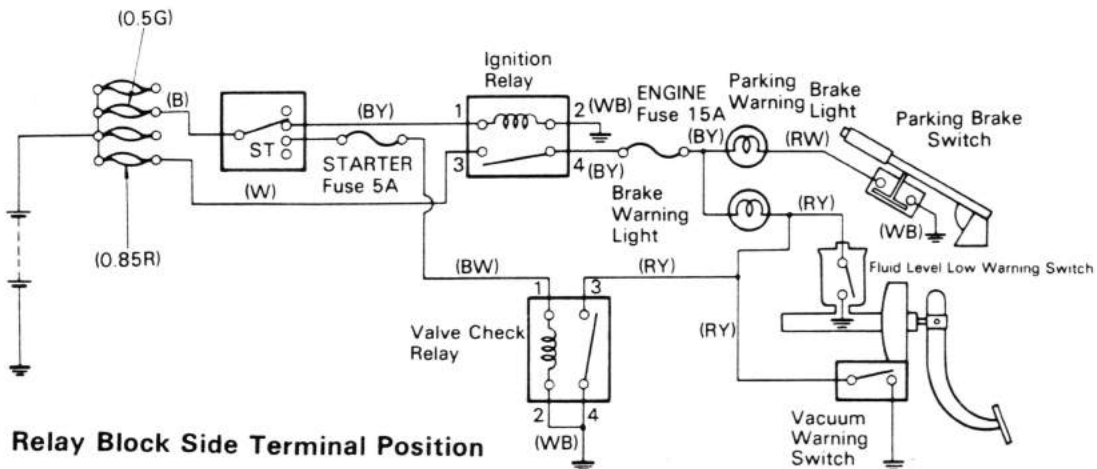

Relay Block Side Terminal Position

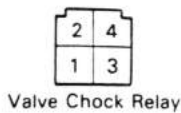
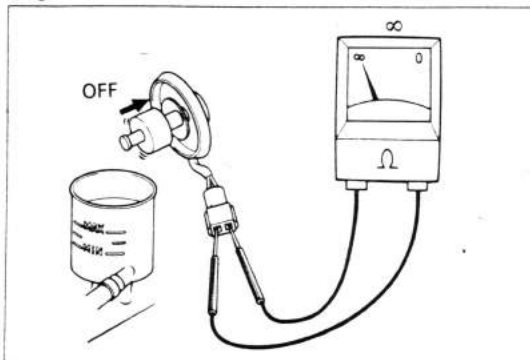

Fig. 13-156



BRAKE FLUID LOW LEVEL WARNING SWITCH

ON-VEHICLE INSPECTION

When the float is up, the lead switch should be OFF (∞).

Fig. 13-157

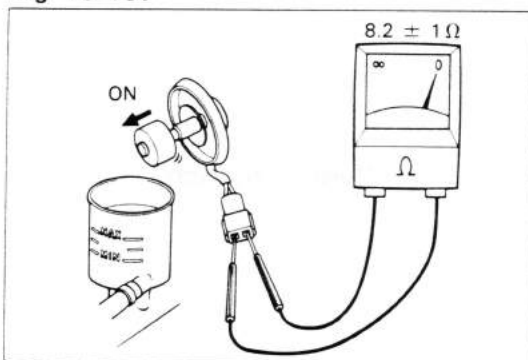

When the float is down, the lead switch should be ON ($8.2 \pm 1 \Omega$).

Fig. 13-158

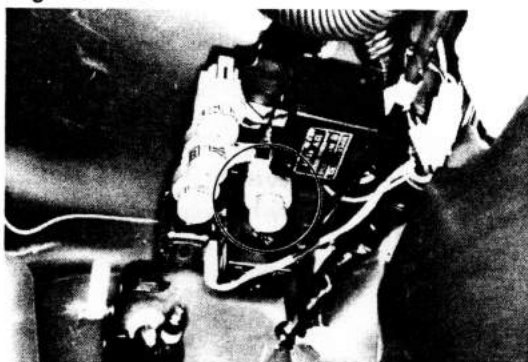

BULB CHECK RELAY INSPECTION

1. Remove the cowl side trim RH.
2. Remove the rear fog light relay from the relay block No.1.

Fig. 13-159

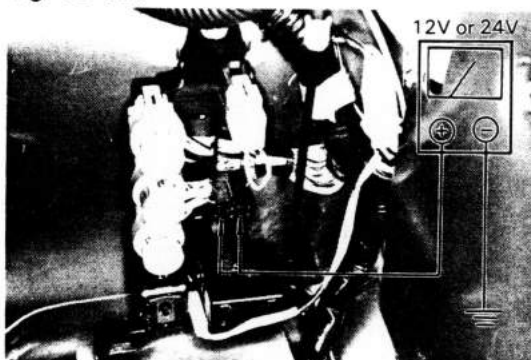

Turn on the ignition or starter switch at the ST position, check to see that there is battery voltage at terminal 1 and 3.

Fig. 13-160

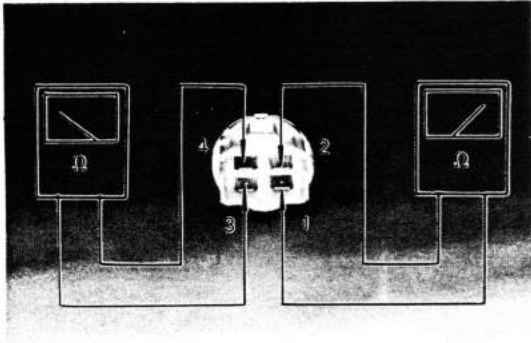

3. Measure resistance between terminals.

Between terminals	Resistance (Ω)	
	1 — 3	12V
approx.65		245
2 — 4	∞	∞

Fig. 13-161

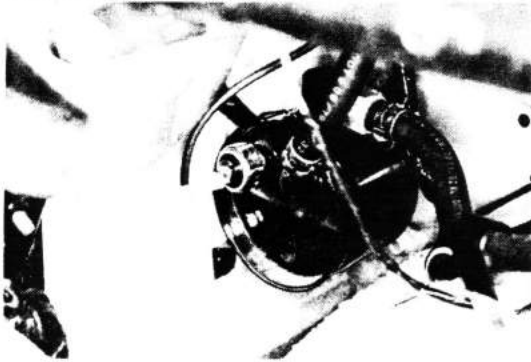

Vacuum Warning Switch

Check the continuity between terminals.

- With engine running ON
- With engine stopping OFF

Fig. 13-162

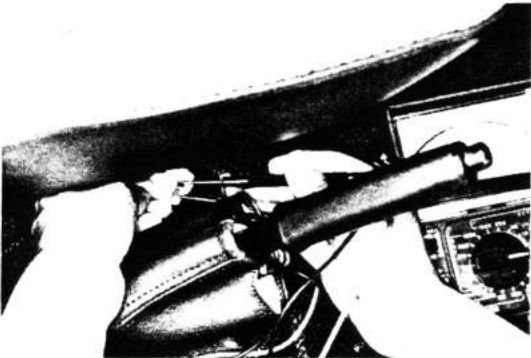

Parking Brake Switch

Check the continuity between terminals.

- When pulling the lever ON
- When release the lever OFF

REAR WINDOW DEFOGGER CIRCUIT DIAGRAM

Fig. 13-163

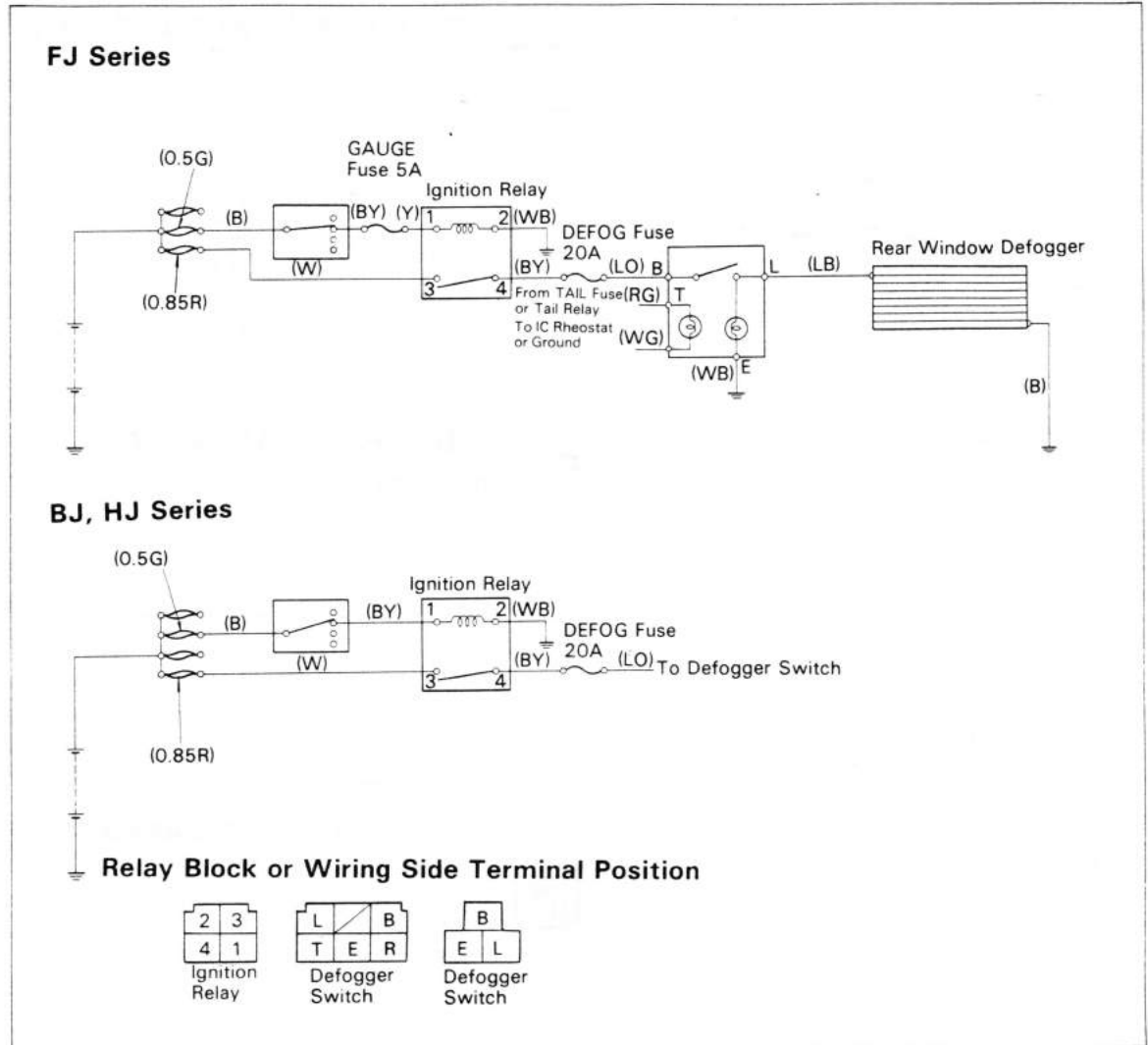
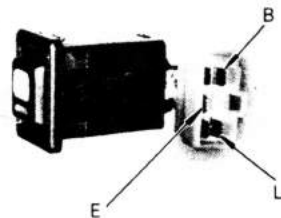

Fig. 13-164



INSPECTION



1. Check the continuity between terminals. If there is a continuity between terminals as shown in the table below, the switch is in good condition.

Terminal Switch position	B	L	E
OFF		○—○	○—○
ON	○—○	○—○	○—○

cardiagn.com

Fig. 13-165

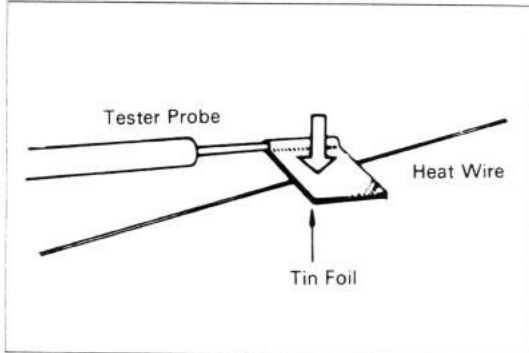

HEAT WIRE PRECAUTIONS

1. Clean the glass with a soft, dry cloth, wiping in the direction of the wires and using care not to damage the wires.
2. Do not use detergents or glass cleaners containing abrasive ingredients.
3. To prevent the tip of tester probe from damaging the heat wire when measuring the voltage, wind a strip of tin foil around the tip and check by pressing the other end of foil against the heat wire with your finger.

Fig. 13-166

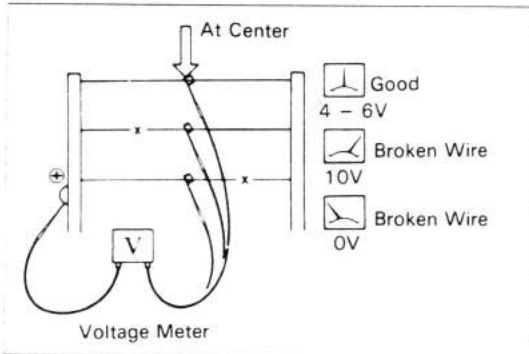

PRINTED HEAT WIRE

INSPECTION

1. Turn ON the defogger.
2. Check the voltage at the center of each heat wire.

Voltage	Criteria
approx. 5V	Good (No Break in wire)
approx. 10V or 0V	Broken wire

Fig. 13-167

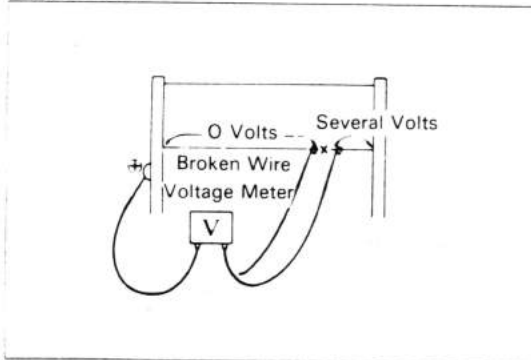

CHECK FOR WIRE BREAKAGE POINT

1. Place the voltmeter (+) lead against the defogger (+) terminal.
2. Place the voltmeter (-) lead with the foil strip against the heat wire at (+) terminal end, and shift it toward the (-) terminal end.
3. The point where the voltmeter deflects from zero volts to several volts is the place where the heat wire is broken.

REPAIR

1. Preparatory materials
 - (1) Fine pointed brush, size 0 or similar
 - (2) White gasoline
 - (3) Masking tape
 - (4) Repair agent: Dupont Paste No. 4814
2. Repair method
 - (1) Clean where the wire is broken.
 - (2) As illustrated stick masking tape under the place that is to be repaired.
 - (3) Thoroughly mix the repair agent, dip a small amount on a fine brush, and paint it on the part to be repaired.
 - (4) After one or two minutes, peel off the masking tape.
 - (5) Allow to stand at least 24 hours after repairing before turning the defogger on.

Fig. 13-168

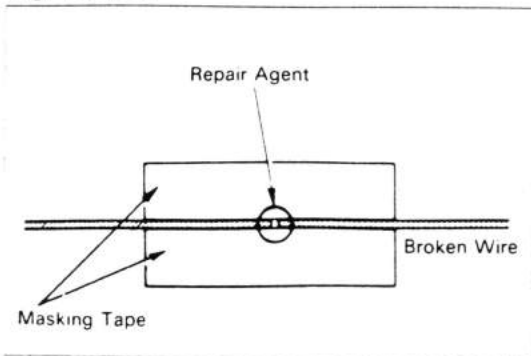

SEAT BELT WARNING CIRCUIT DIAGRAM

Fig. 13-169

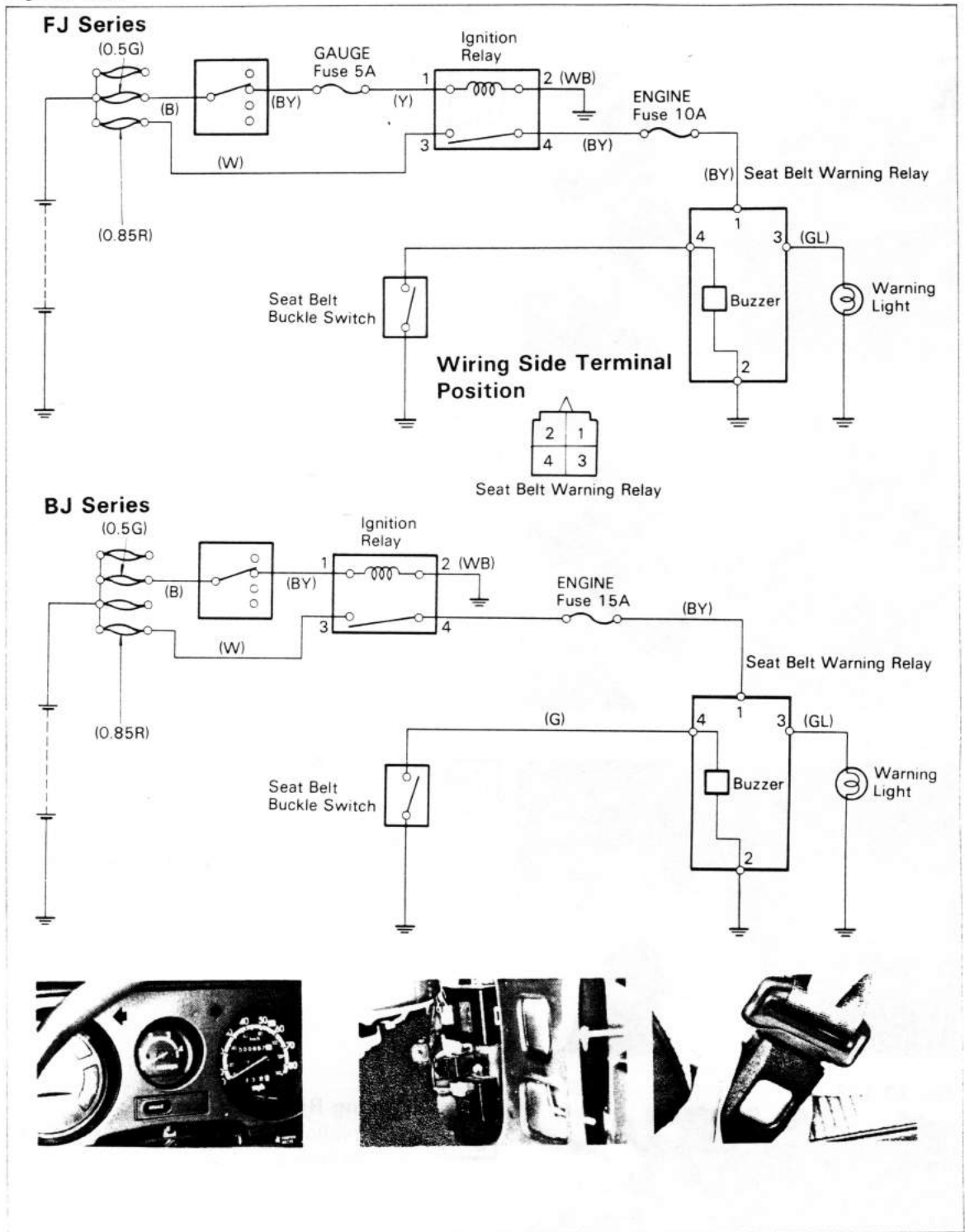

cardiagn.com

Fig. 13-170

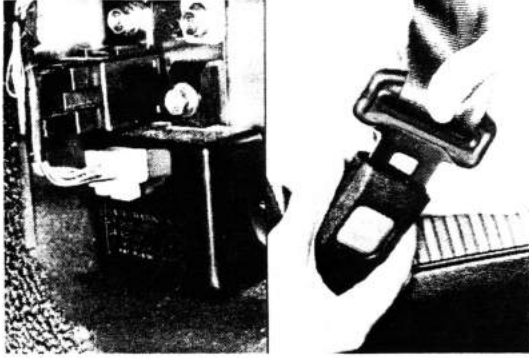
**INSPECTION**

1. Inspect the buzzer.

Fig. 13-171

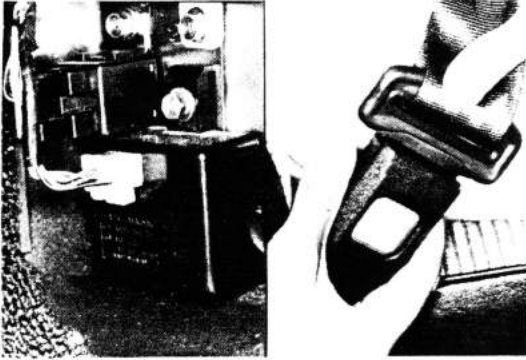

2. Inspect the buzzer

Fig. 13-172

**Buckle Switch**

Inspect the switch.

– Note –

Buckle switch is installed under the center console.

Fig. 13-173

**Warning Relay**

Battery voltage should be applied between 1 and 2 terminals.

HEATER CIRCUIT DIAGRAM

Fig. 13-174

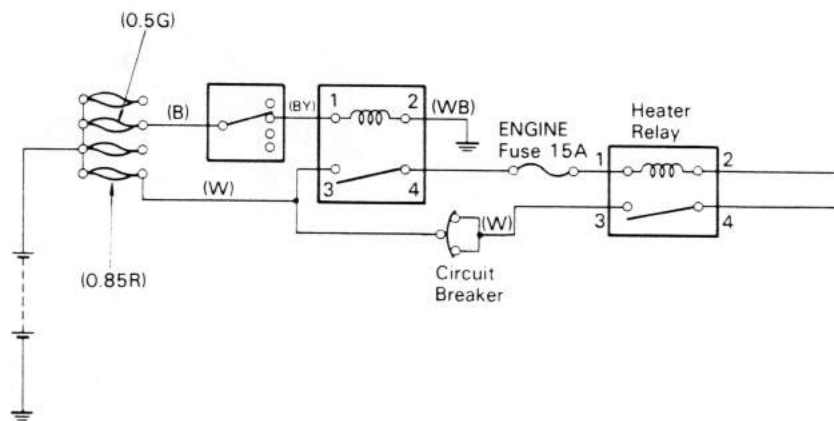
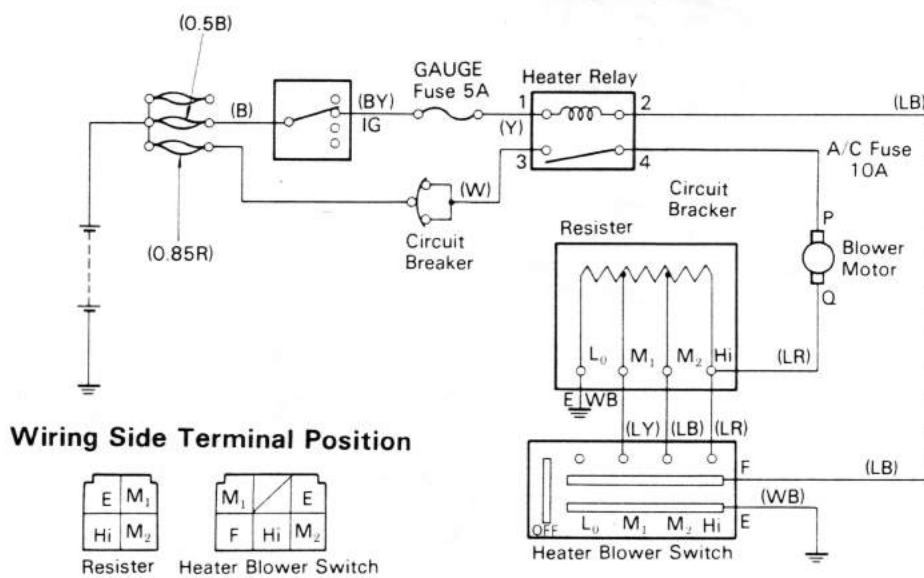
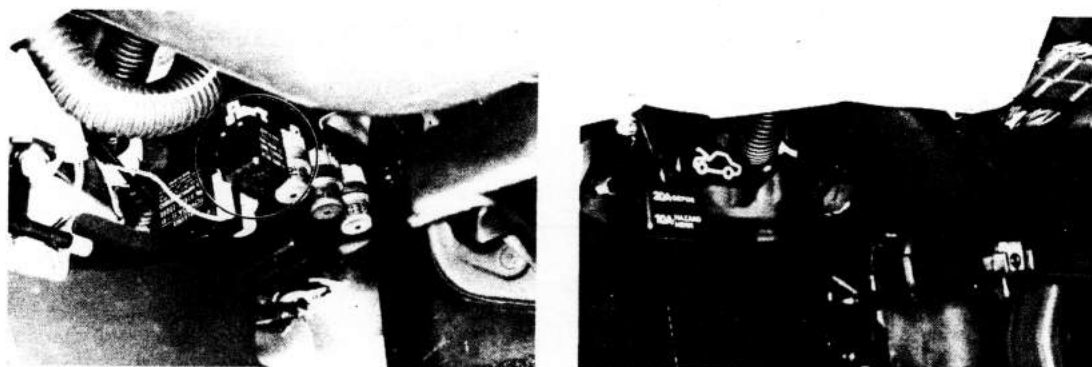

HEATER BLOWER SWITCH**REMOVAL**

Remove the parts in the numerical order shown in the figure.

Fig. 13-175

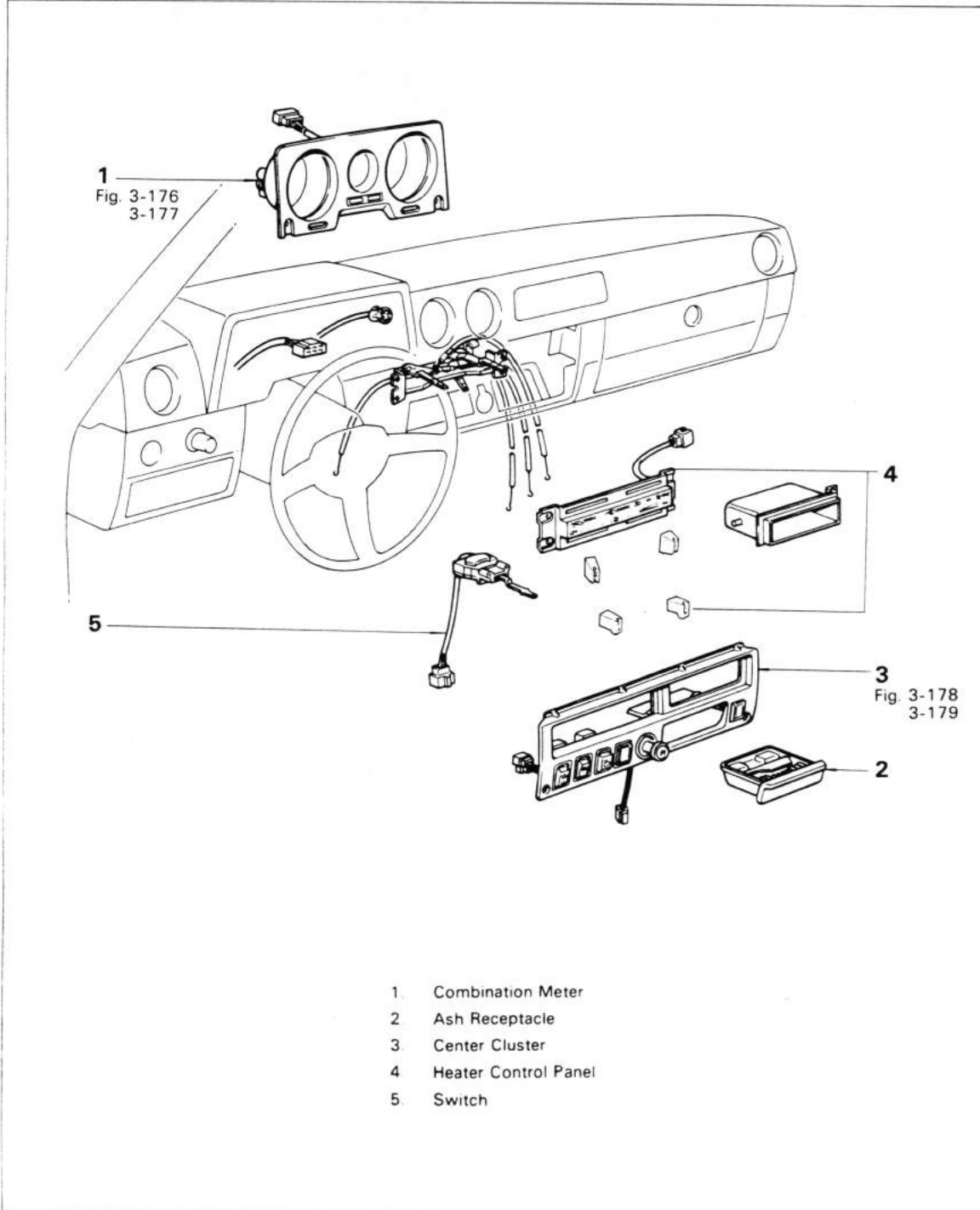
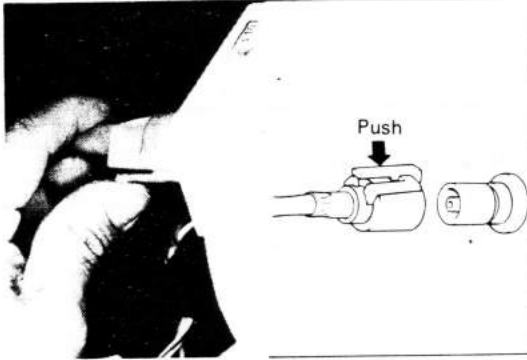
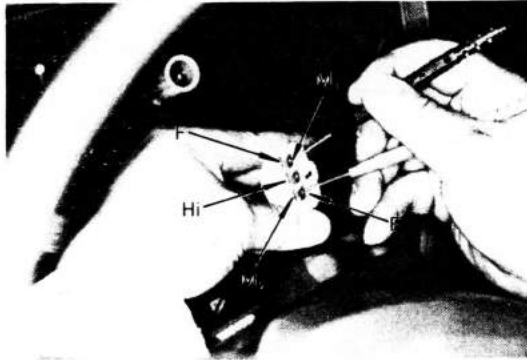

Fig. 13-176



Before removing the combination meter, pull out the cable while pushing the lock lever.

Fig. 13-177



Before removing the switch, check continuity between terminals.

Terminal Position \ Terminal	E	F	Hi	M ₂	M ₁	Lo
OFF						
Low	○—○					
M ₁	○—○	○—○	○—○	○—○	○—○	
M ₂	○—○	○—○		○—○		
Hi	○—○	○—○	○—○			

Fig. 13-178

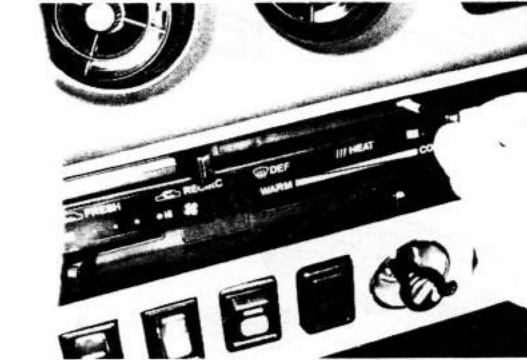

Remove the knobs by pulling its.

Fig. 13-179

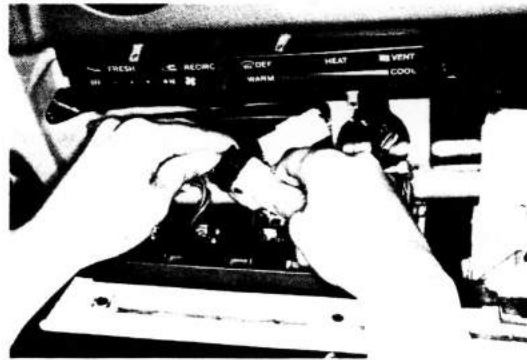

Before removing the center panel, disconnect the connectors.

INSTALLATION

Install the parts in the numerical order shown in the figure.

Fig. 13-180

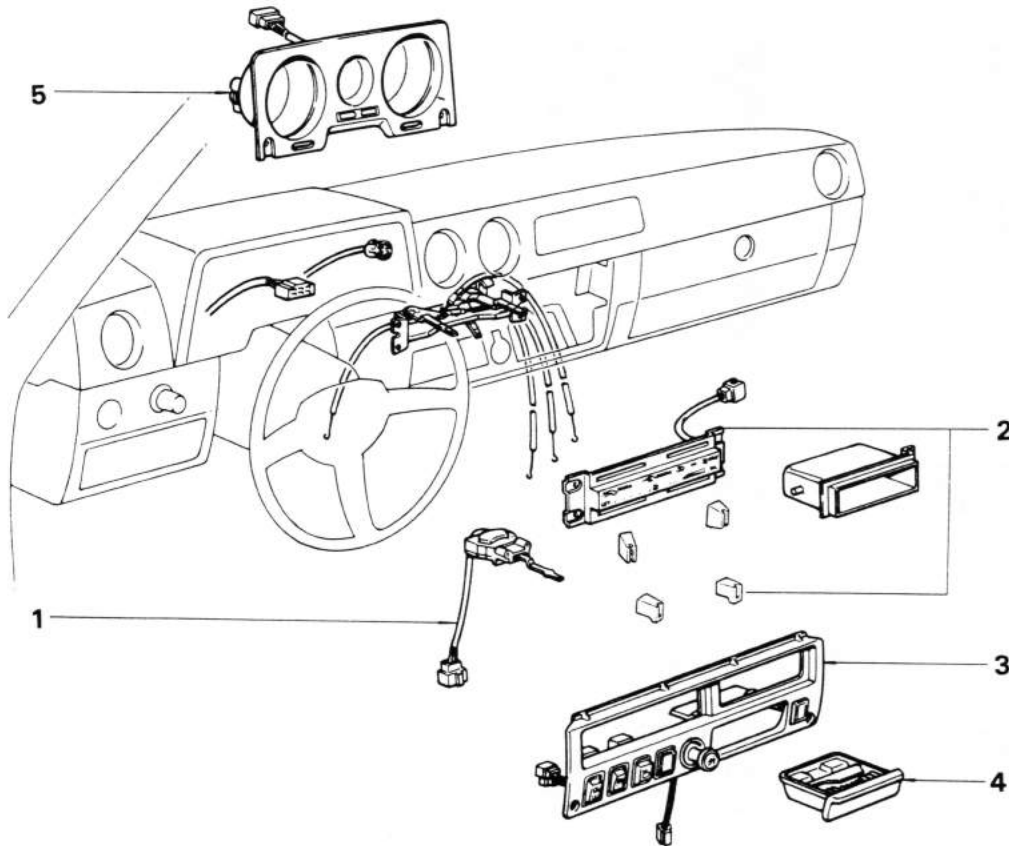

1. Switch
2. Heater Control Panel
3. Center Cluster
4. Ash Receptacle
5. Combination Meter

Fig. 13-181

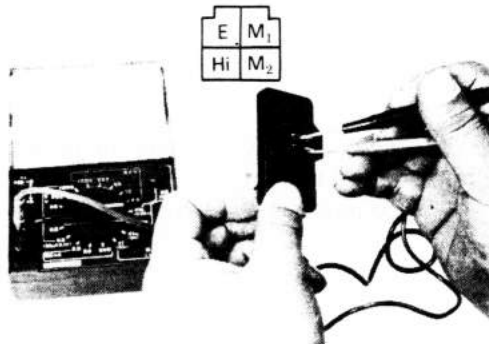

BLOWER RESISTOR



INSPECTION

Measure continuity between terminals.

Fig. 13-182

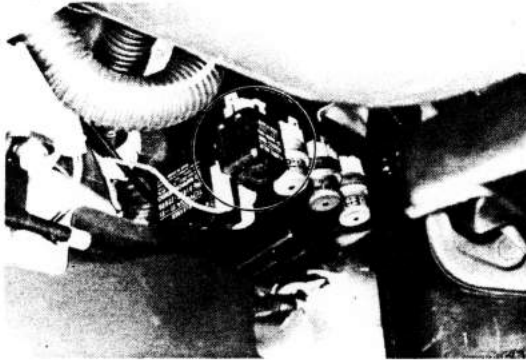

HEATER RELAY



INSPECTION

1. Check to see that there is an operational noise from the relay when turn on the switch.

Fig. 13-183

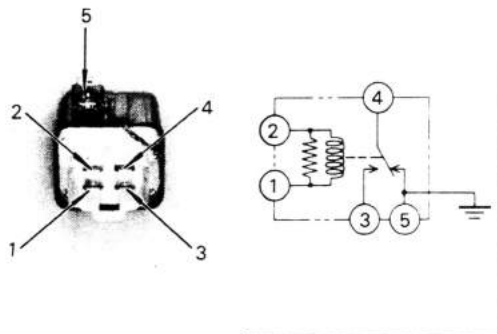

2. Measure continuity between terminals.

Between terminals	Resistance Ω	
	12V	24V
1 — 2	75 Ω	226 Ω
3 — 4	0	

Fig. 13-184



CIRCUIT BREAKER

Remove the circuit breaker near the fuse block.

Fig. 13-185

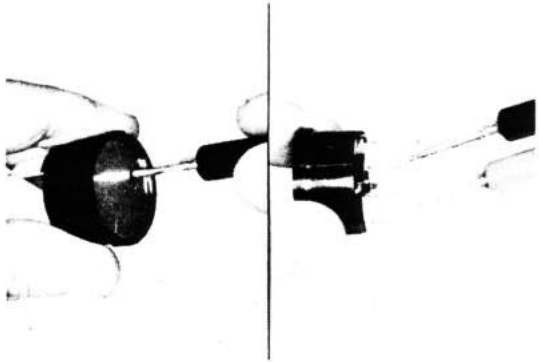

Reset the breaker by inserting the needle into the hole and push it.
Check continuity between terminals.

HEATER BLOWER MOTOR

REMOVAL

Remove the parts in the numerical order shown in the figure.

Fig. 13-186

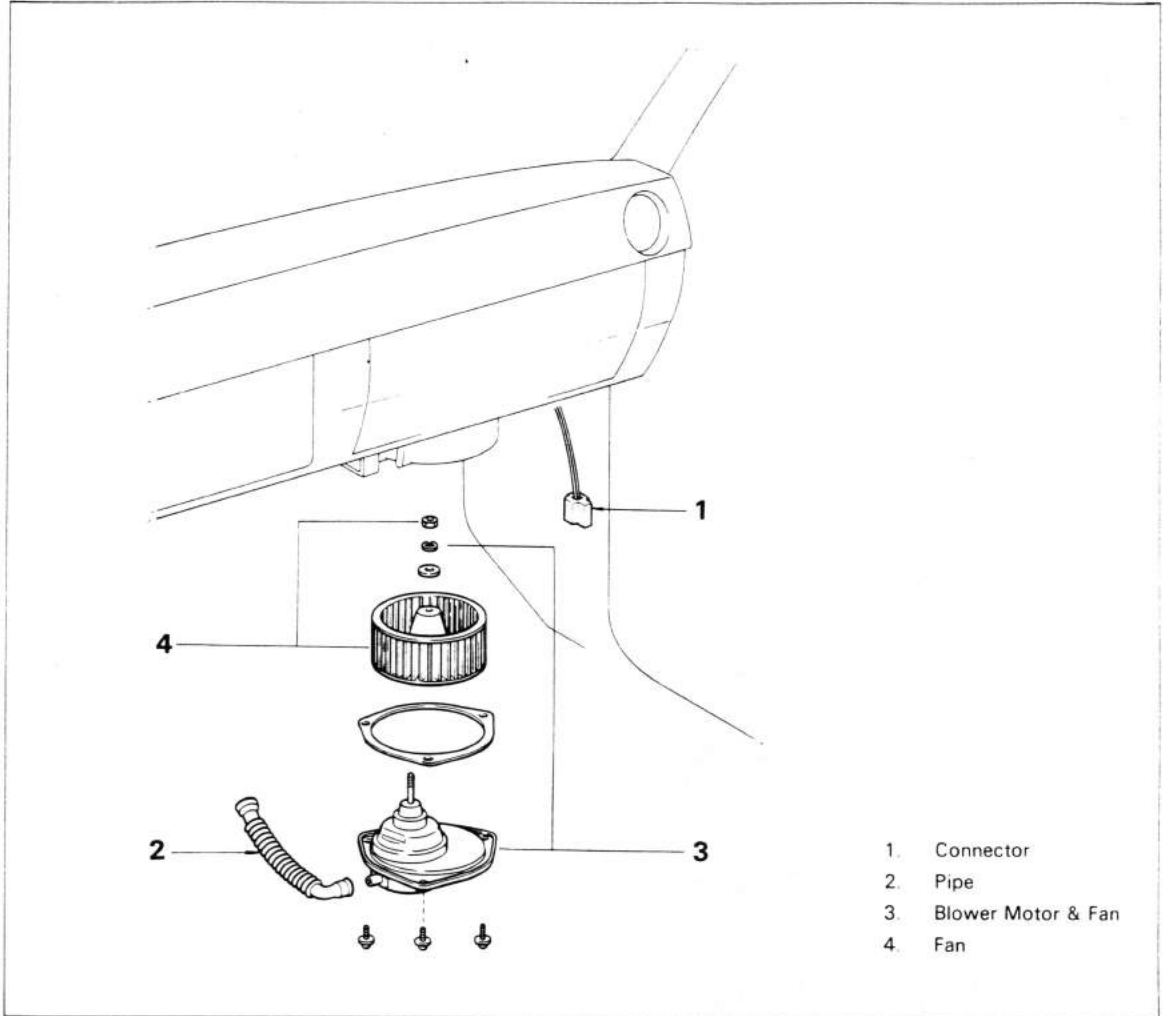
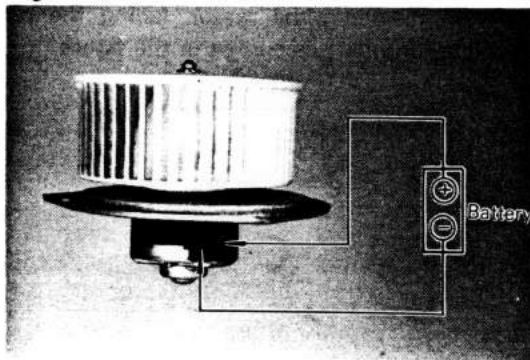

Fig. 13-187



INSPECTION



Apply the battery voltage to the connector check to see that the motor rotates smoothly.

INSTALLATION

Install the parts in the numerical order shown in the figure.

Fig. 13-188

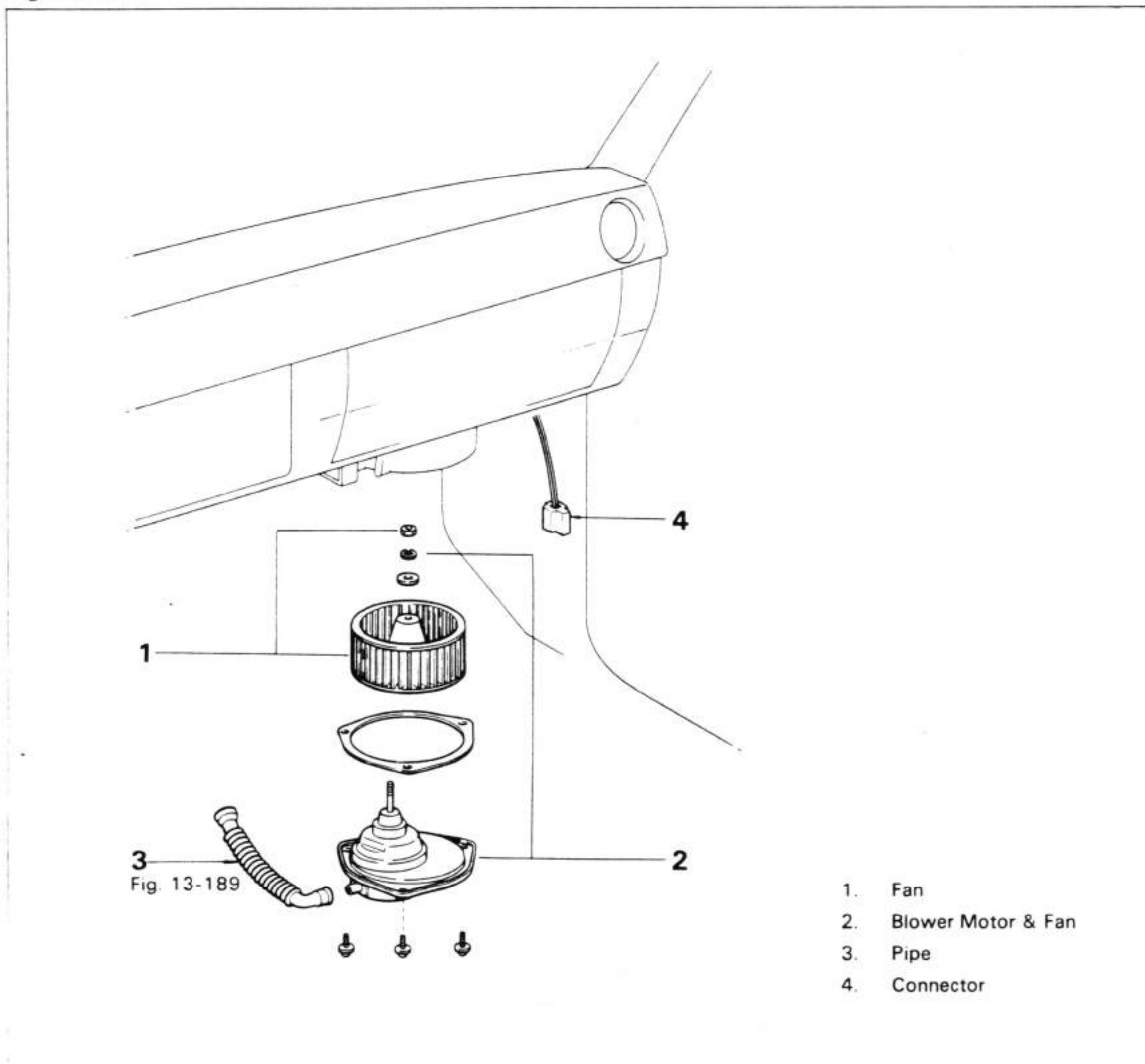
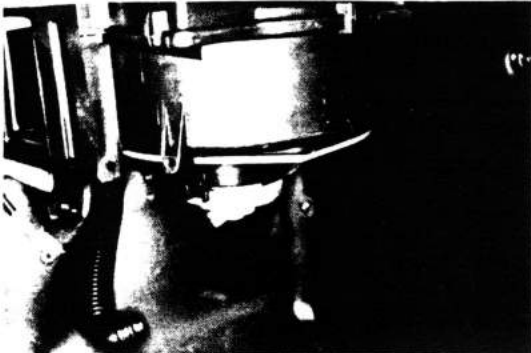

Fig. 13-189



When installing the motor, facing the pipe connecting part as shown in the figure.

AIR INLET UNIT

REMOVAL

Remove the parts in the numerical order shown in the figure.

Fig. 13-190

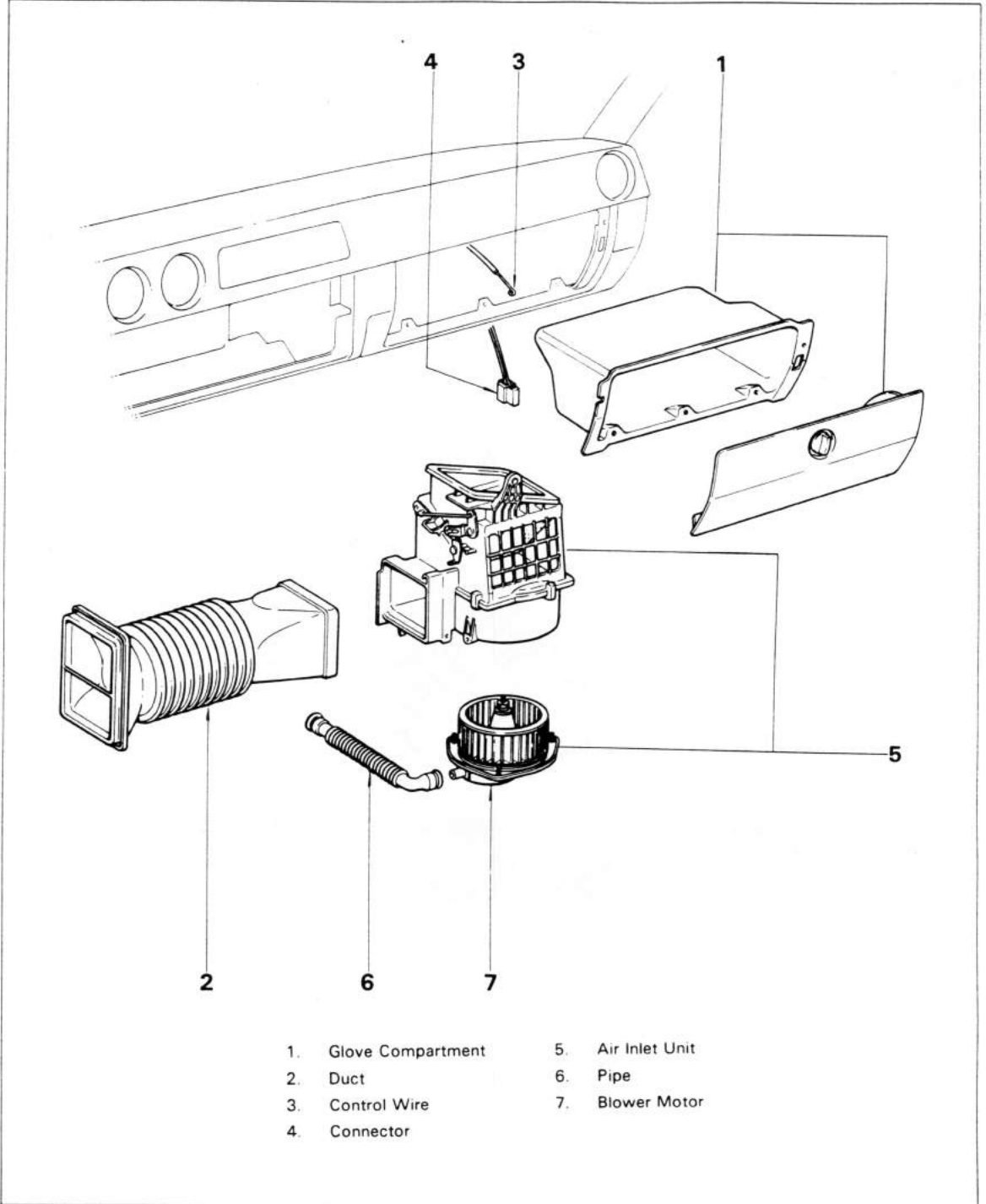

INSTALLATION

Install the parts in the numerical order shown in the figure.

Fig. 13-191

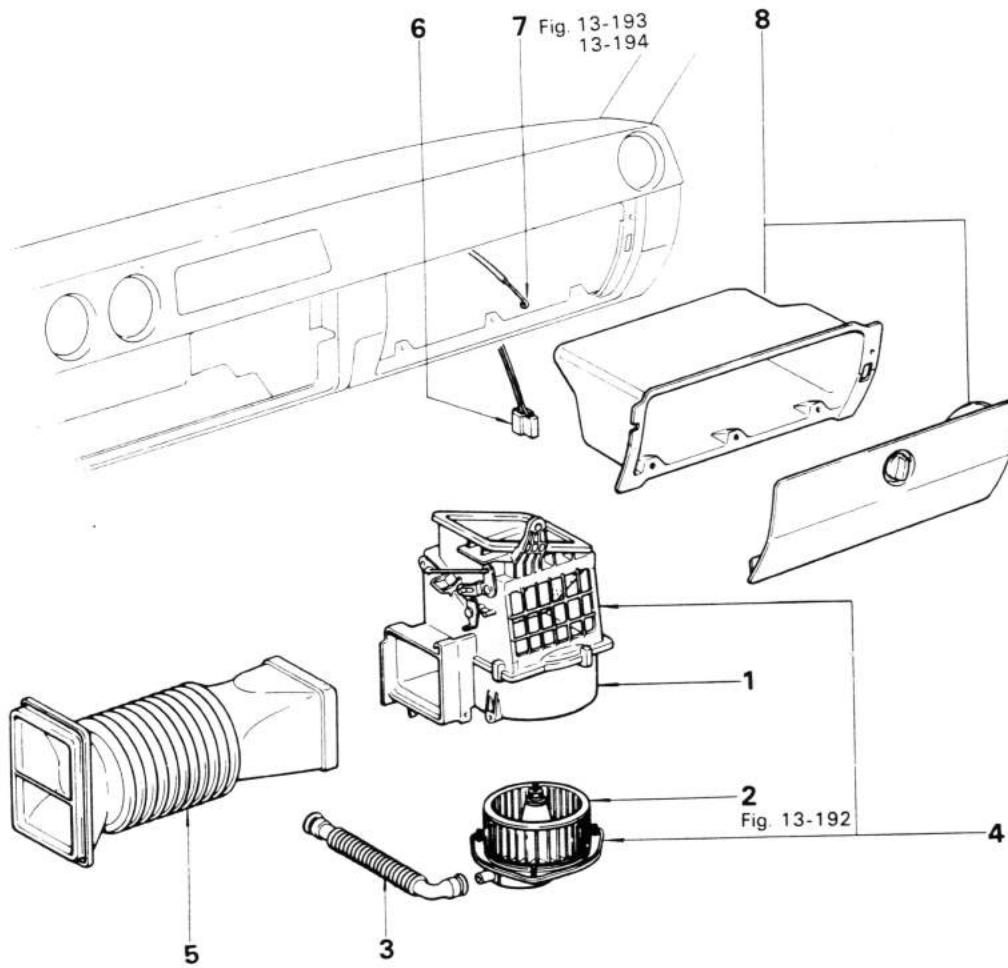

1. Air Inlet Unit
2. Blower Motor
3. Pipe
4. Inlet Unit & Blower Motor
5. Duct
6. Connector
7. Control Wire
8. Glove Compartment

Fig. 13-192

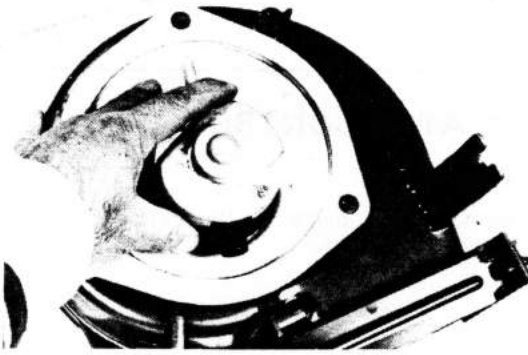

When installing the motor, install the pipe facing as shown in the figure.

Fig. 13-193

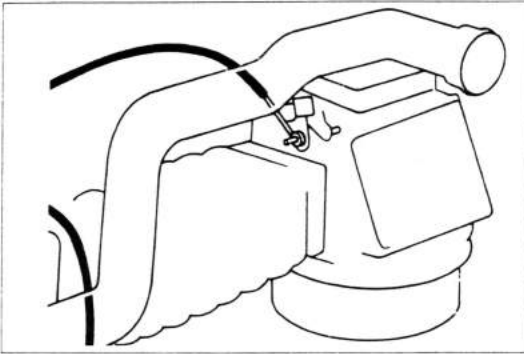

Connect the control wire to the dumper lever.

Fig. 13-194

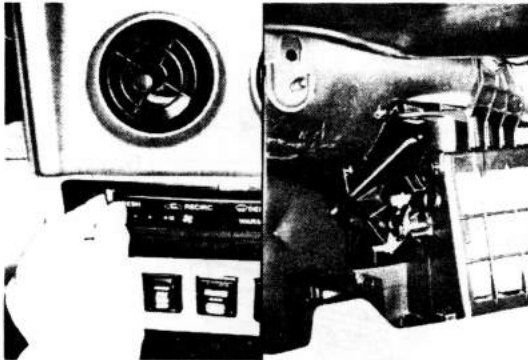

After connecting the control wire, check the lever stiffness and stroke.

HEATER CONTROL**REMOVAL**

Remove the parts in the numerical order shown in the figure.

Fig. 13-195

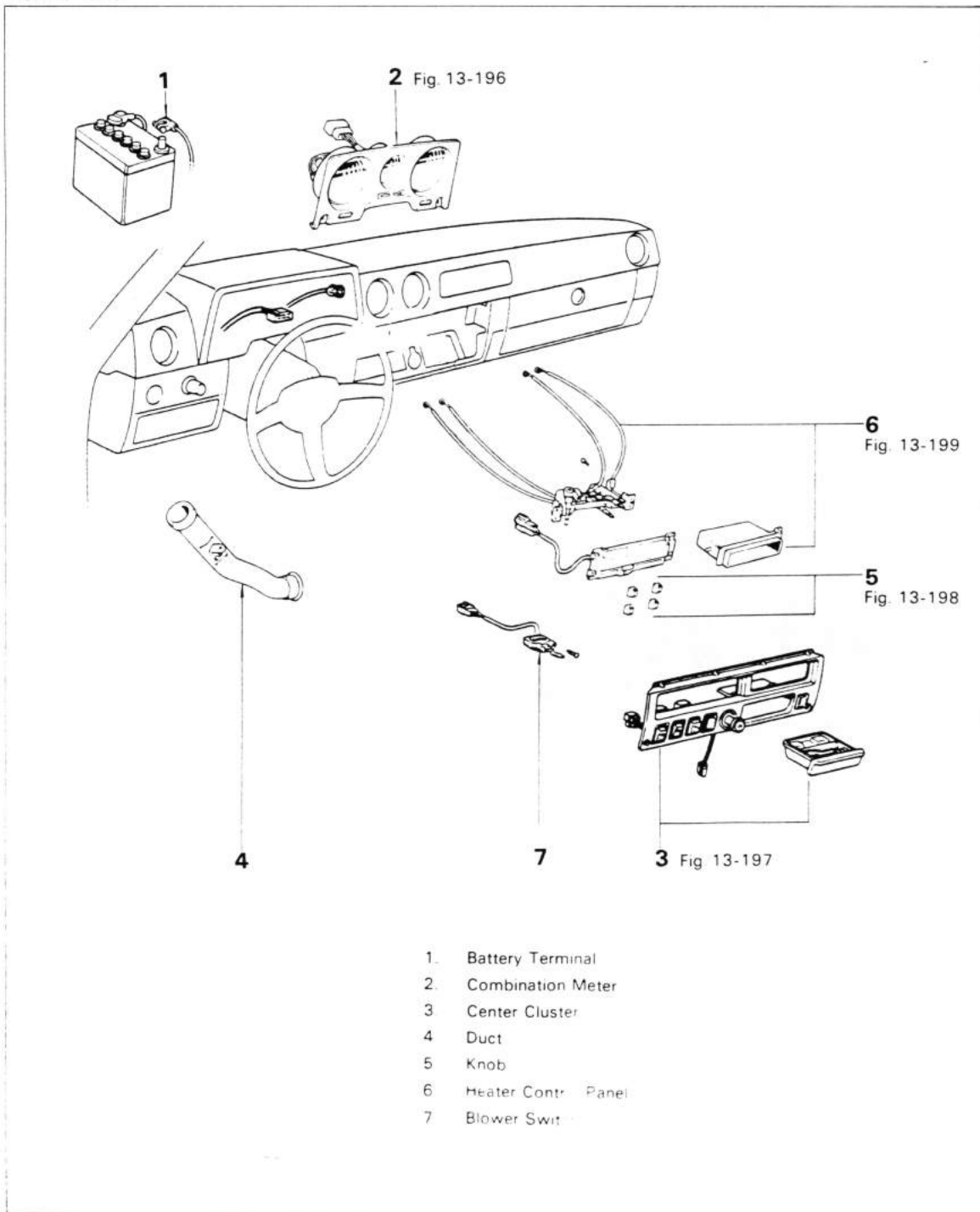

1. Battery Terminal
2. Combination Meter
3. Center Cluster
4. Duct
5. Knob
6. Heater Control Panel
7. Blower Switch

Fig. 13-196

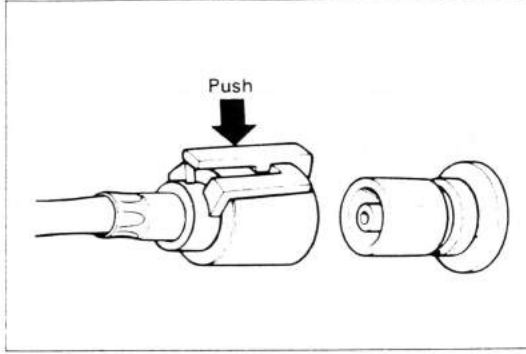

Before removing the combination meter, pull out the cable while pushing the lock lever.

Fig. 13-197



Before removing the center panel, disconnect the connectors.

Fig. 13-198

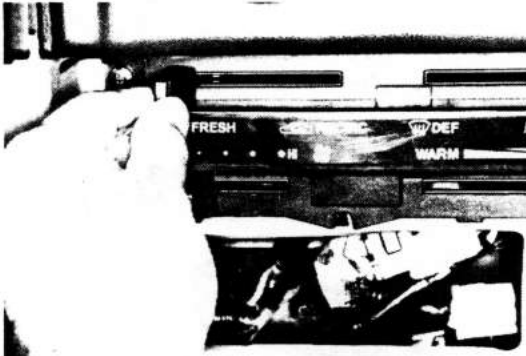

Before removing the panel, pull out the control knobs.

Fig. 13-199

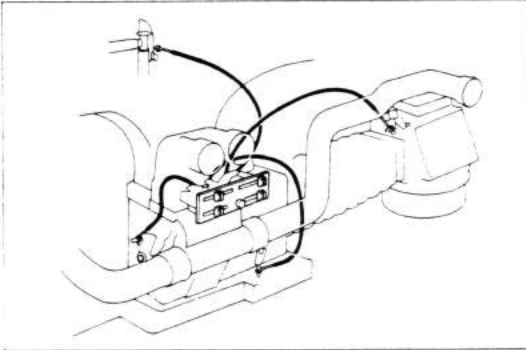

Disconnect the fore cables from their clamps.

INSTALLATION

Install the parts in the numerical order shown in the figure.

Fig. 13-200

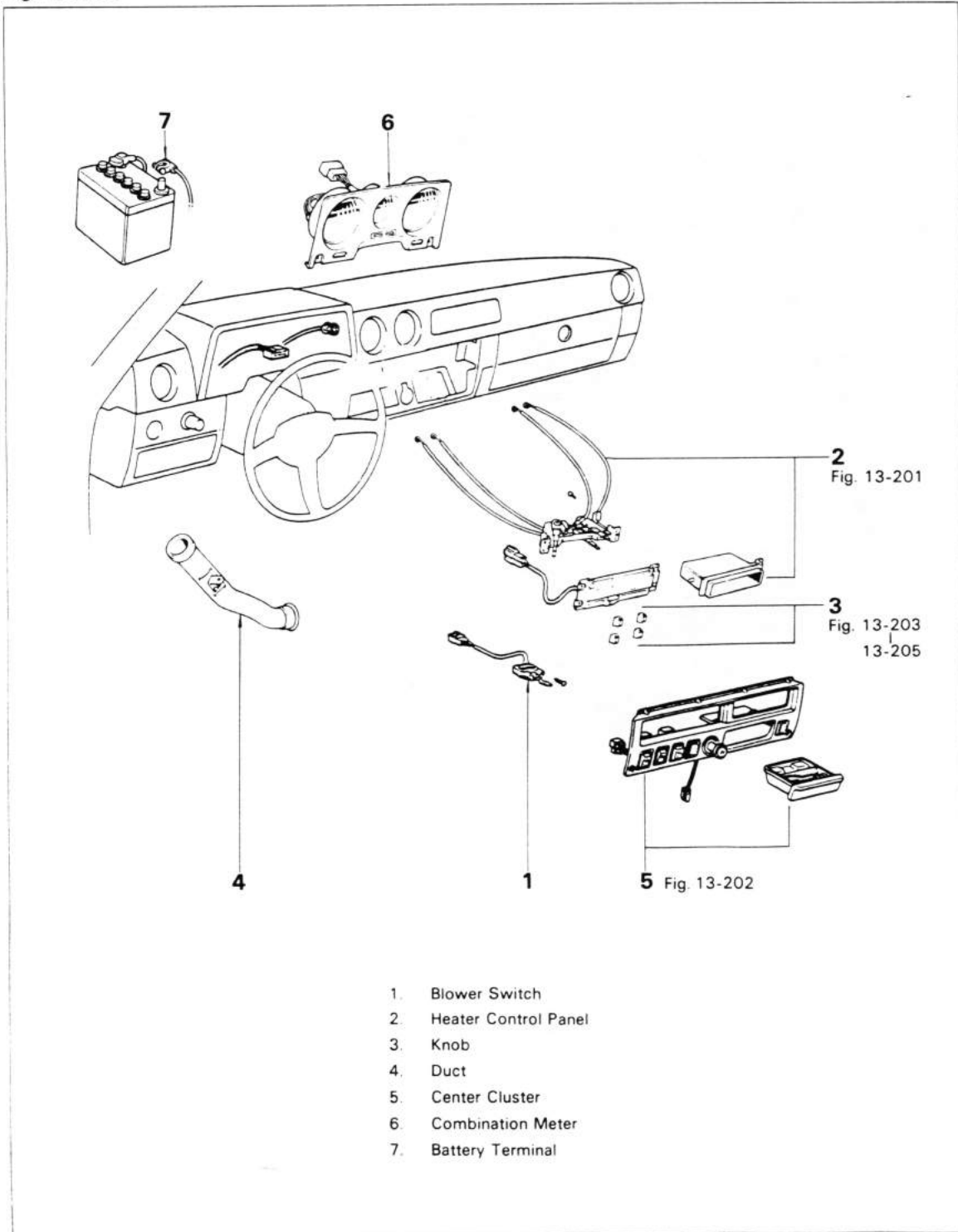

- 1. Blower Switch
- 2. Heater Control Panel
- 3. Knob
- 4. Duct
- 5. Center Cluster
- 6. Combination Meter
- 7. Battery Terminal

Fig. 13-201

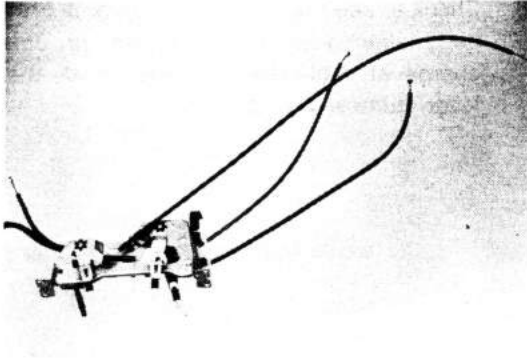

Connect the cables as shown in the figure.

Fig. 13-202



Before installing the center panel, connect the connectors.

Fig. 13-203



Install the knobs and retainer and make sure that the knobs are tight.

Fig. 13-204

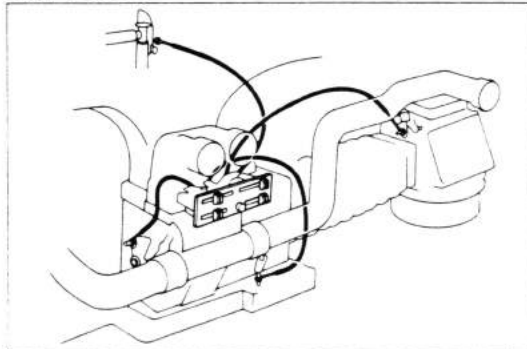

Connect each cable to each control lever and clamp the cables.

Fig. 13-205

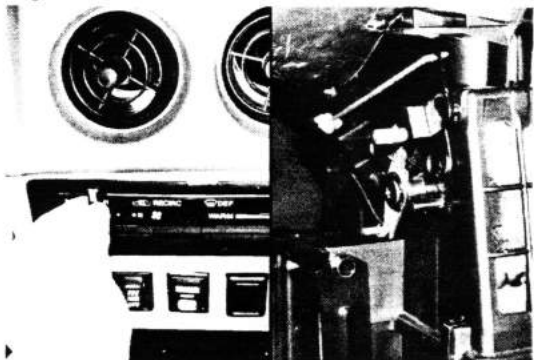

6. Check to see that the control lever is properly aligned by checking the air discharge at each position, and check the lever stiffness and stroke.

HEATER UNIT

REMOVAL

1. Remove the combination meter and heater control.
2. Remove the parts in the numerical order shown in the figure.

Fig. 13-206

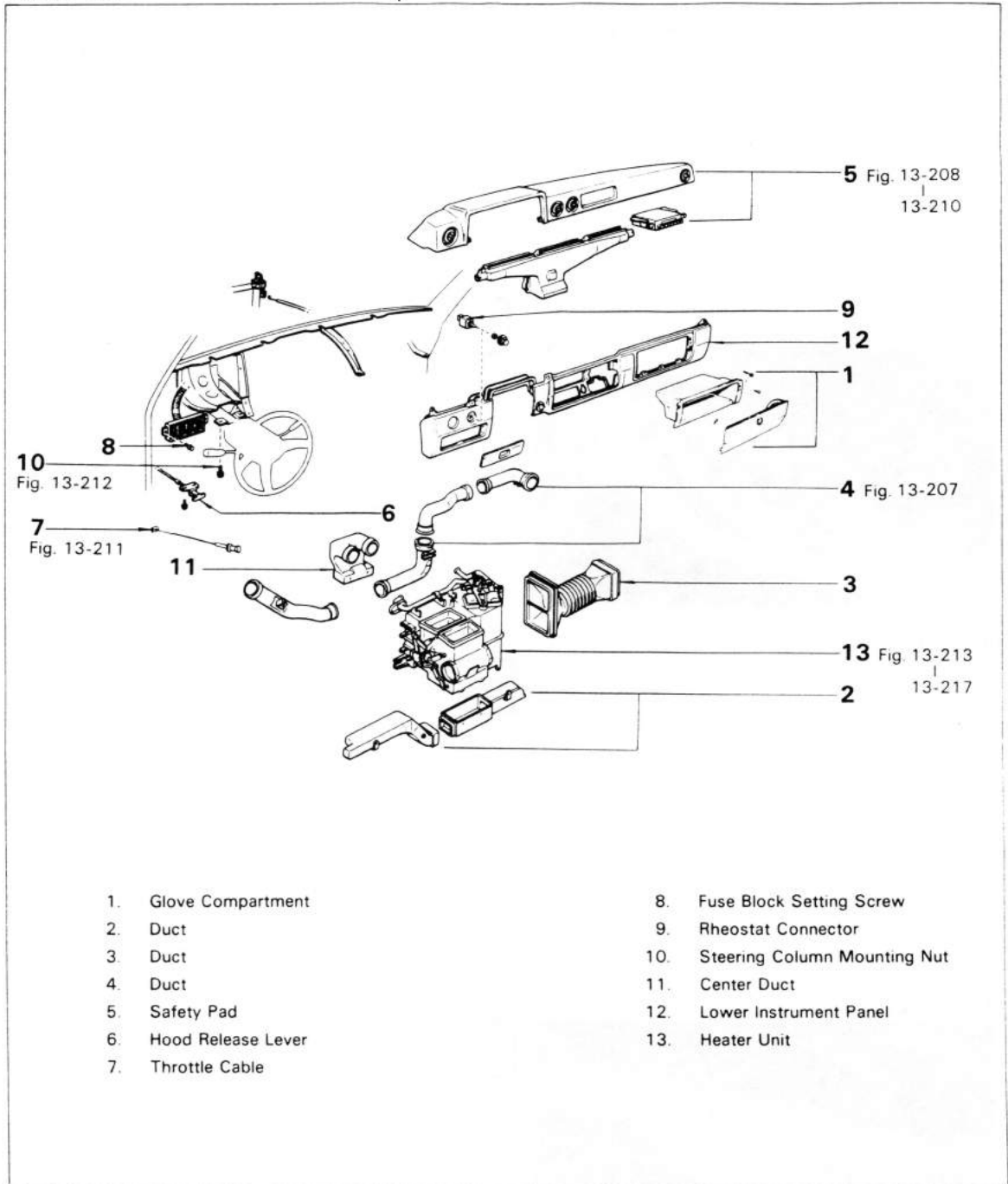

cardiagn.com

Fig. 13-207

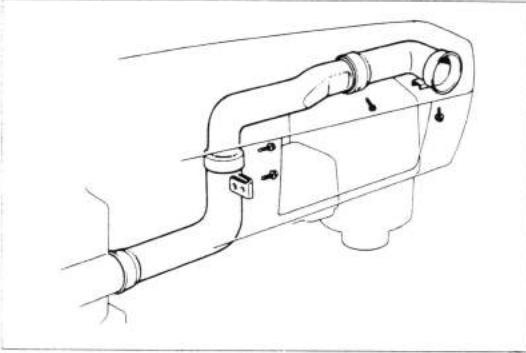

Remove the ducts.

Fig. 13-208

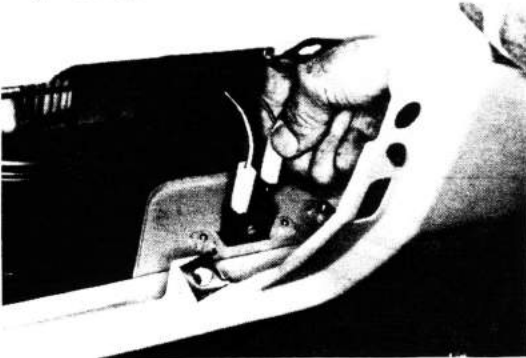

Before removing the instrument panel, disconnect the connector wire.

Fig. 13-209

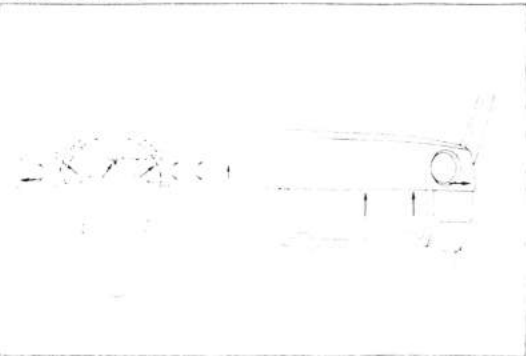

Remove the nuts.

Fig. 13-210



Remove the safety pad.

Fig. 13-211

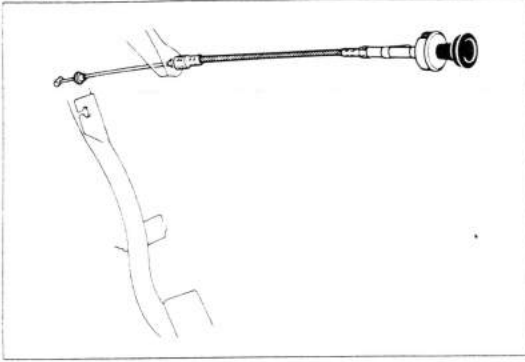

Disconnect the throttle cable.

Fig. 13-212

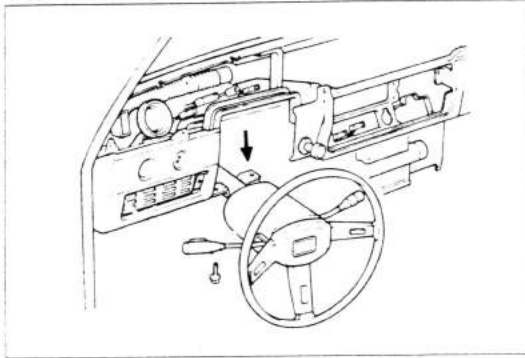

Remove the both side mounting nuts.

Fig. 13-213

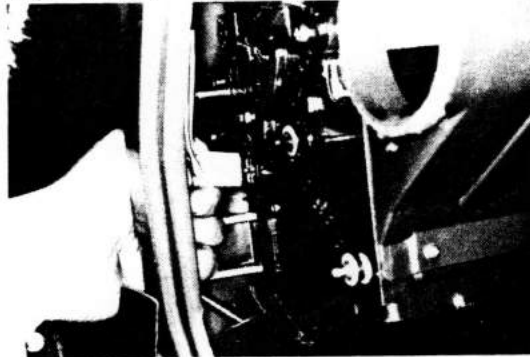

Before removing the unit, disconnect the connector.

Fig. 13-214

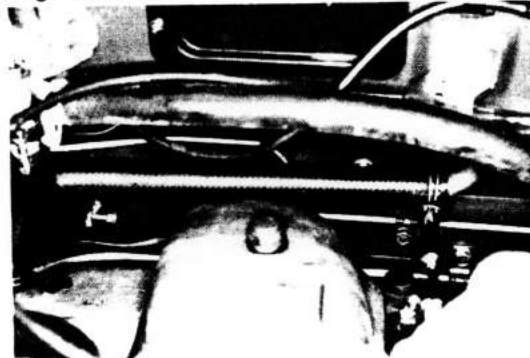

Before removing the unit, disconnect the hoses.

Fig. 13-215

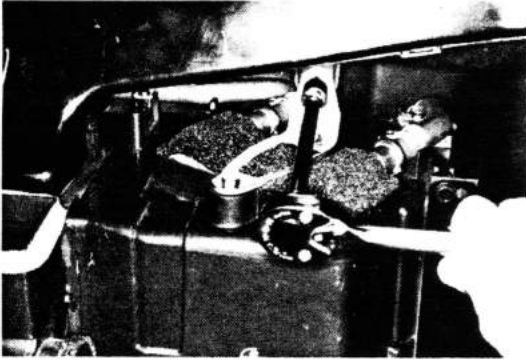

Remove the unit upper side mounting bolt.

Fig. 13-216

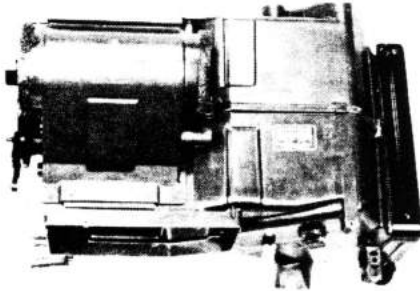

Remove the unit lower side mounting bolts.

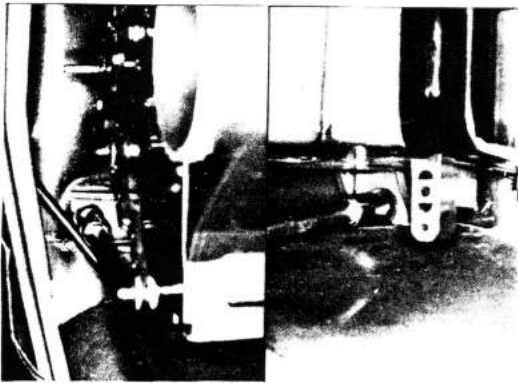
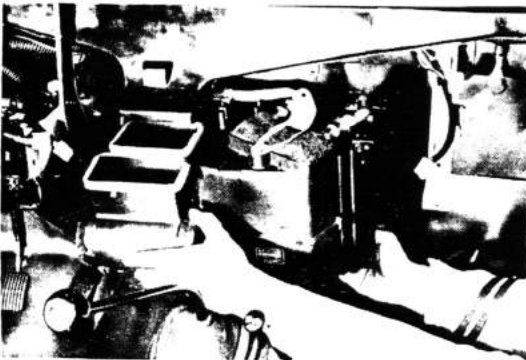

Fig. 13-217



Remove the unit.

Fig. 13-218



Replace The Radiator

1. Remove the pipes and radiator clamps.

Fig. 13-219

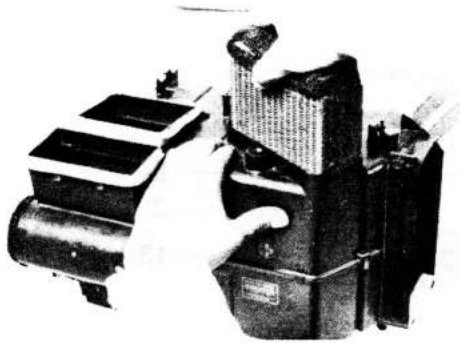

2. Replace the radiator



Fig. 13-220

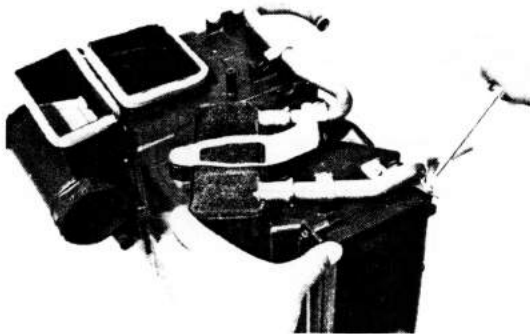

3. Install the radiator and pipe clamps.

INSTALLATION

1. Install the parts in the numerical order shown in the figure.

Fig. 13-221

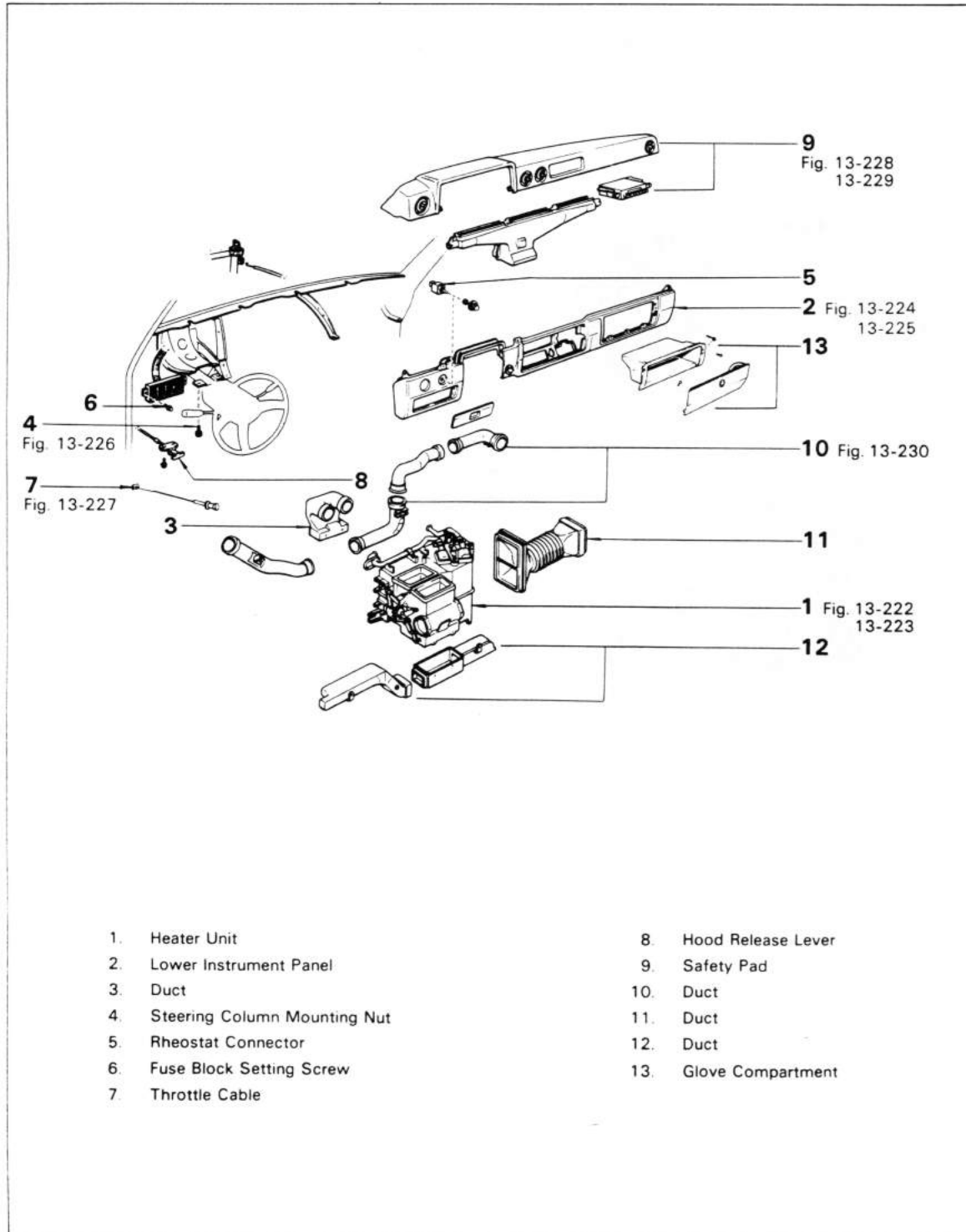
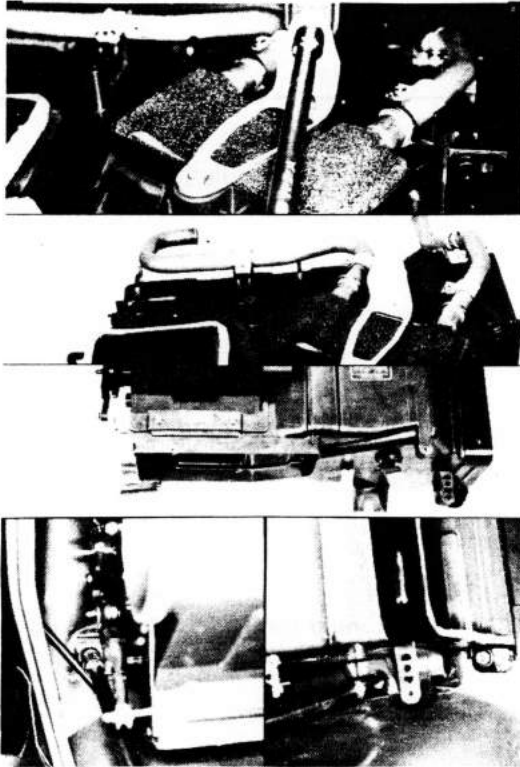
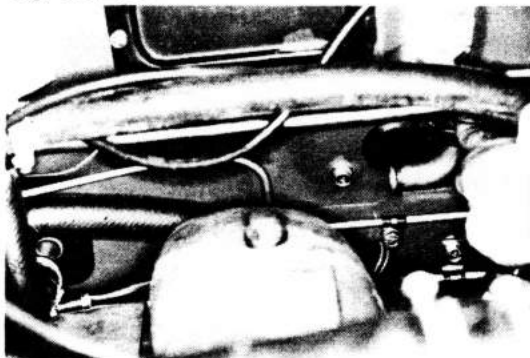

Fig. 13-222



Install the mounting nut and bolts.

Fig. 13-223



Install the gromet from the engine compartment.

Fig. 13-224

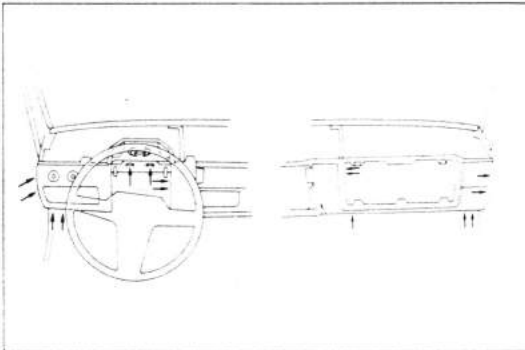

Install the instrument panel as shown in the figure.

Fig. 13-225

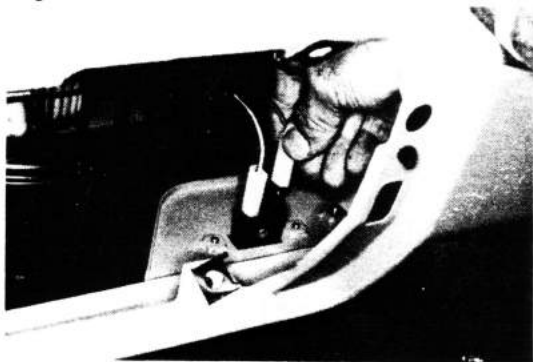

Connect the inspection light wire.

Fig. 13-226

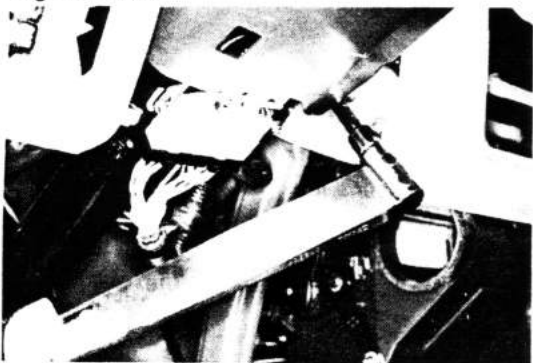

Tighten the column upper bracket.

**Tightening torque: 1.9 – 3.1 kg-m
(14 – 15 ft-lb)**

Fig. 13-227

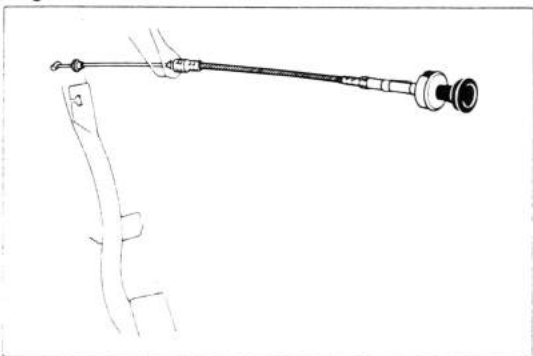

Connect the throttle cable.

Fig. 13-228



Install the safety pad.

Fig. 13-229

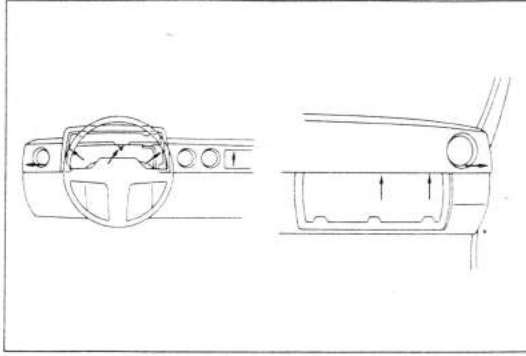

Install the safety pad mounting bolts.

Fig. 13-230

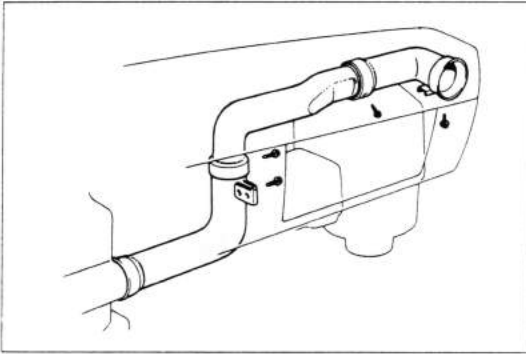

Install the duct.

2. Install the parts in the numerical order shown in the figure.

Fig. 13-231

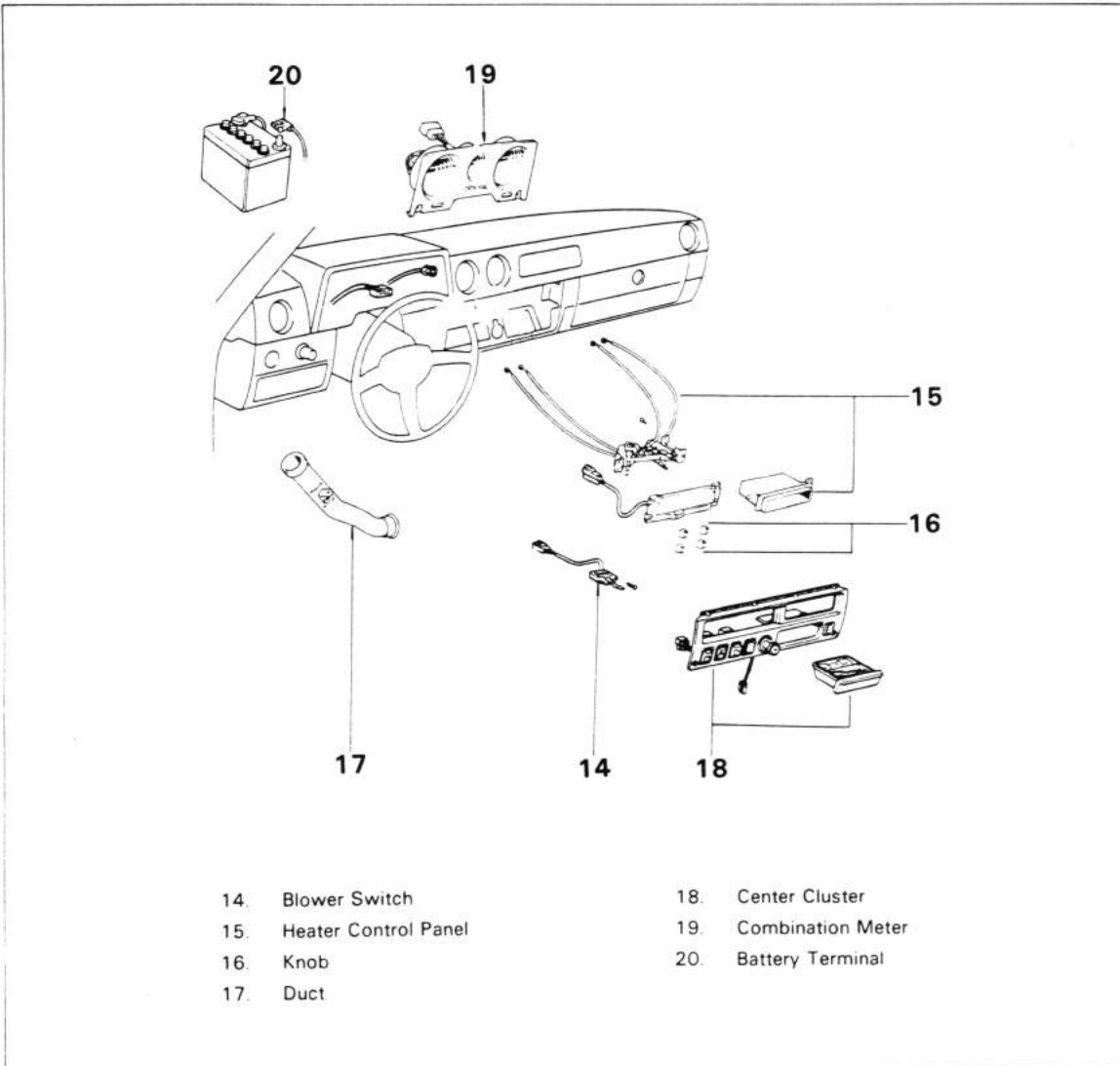

Fig. 13-232

**SEE
HEATER CONTROL
INSTALLATION SECTION
Fig. 13-200 to 13-205**

Install the heater control.

RADIO & STEREO TAPE PLAYER CIRCUIT DIAGRAM

Fig. 13-233

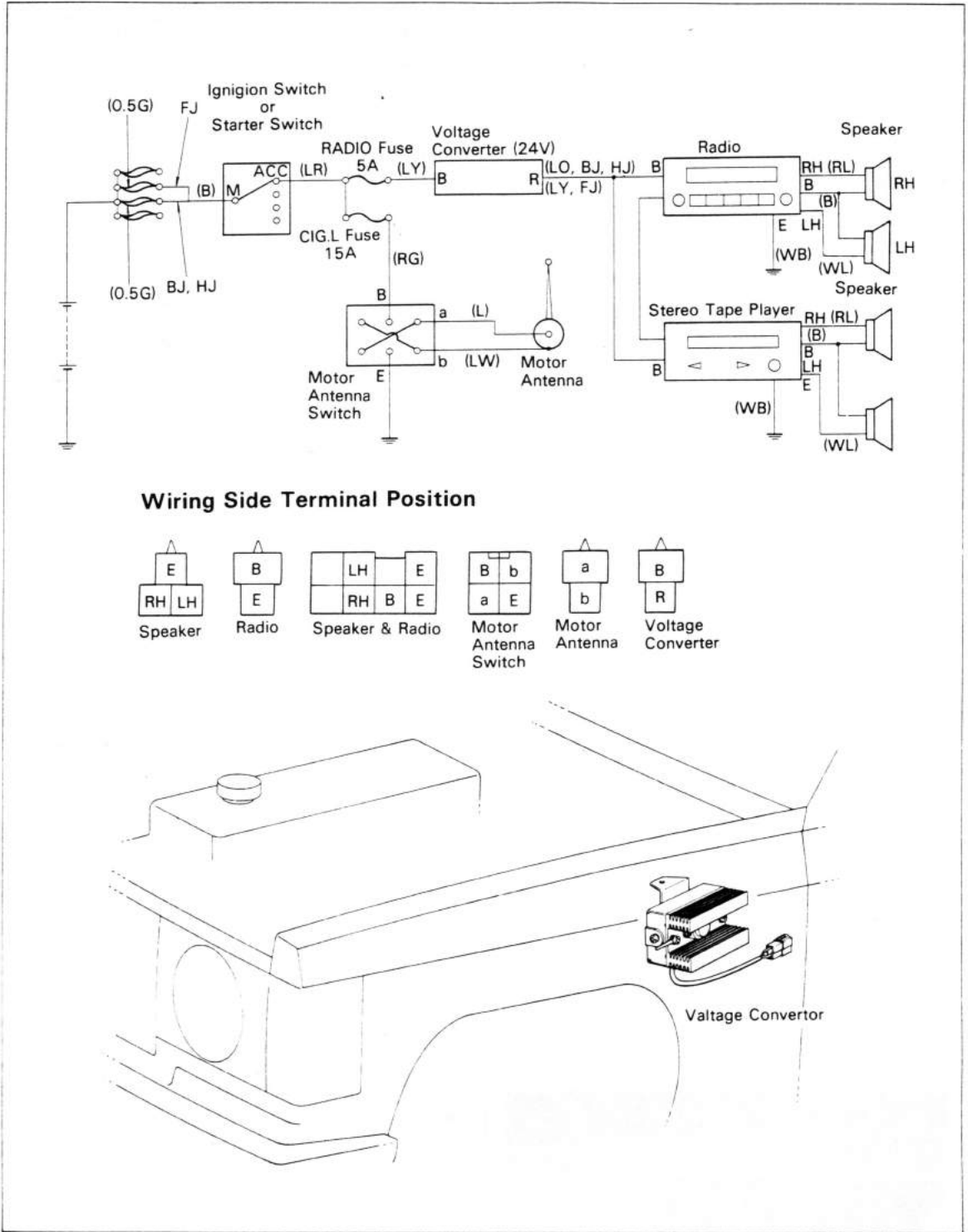

cardiagn.com

RADIO & STEREO TAPE PLAYER

REMOVAL

Remove the parts in the numerical order shown in the figure.

Fig. 13-234

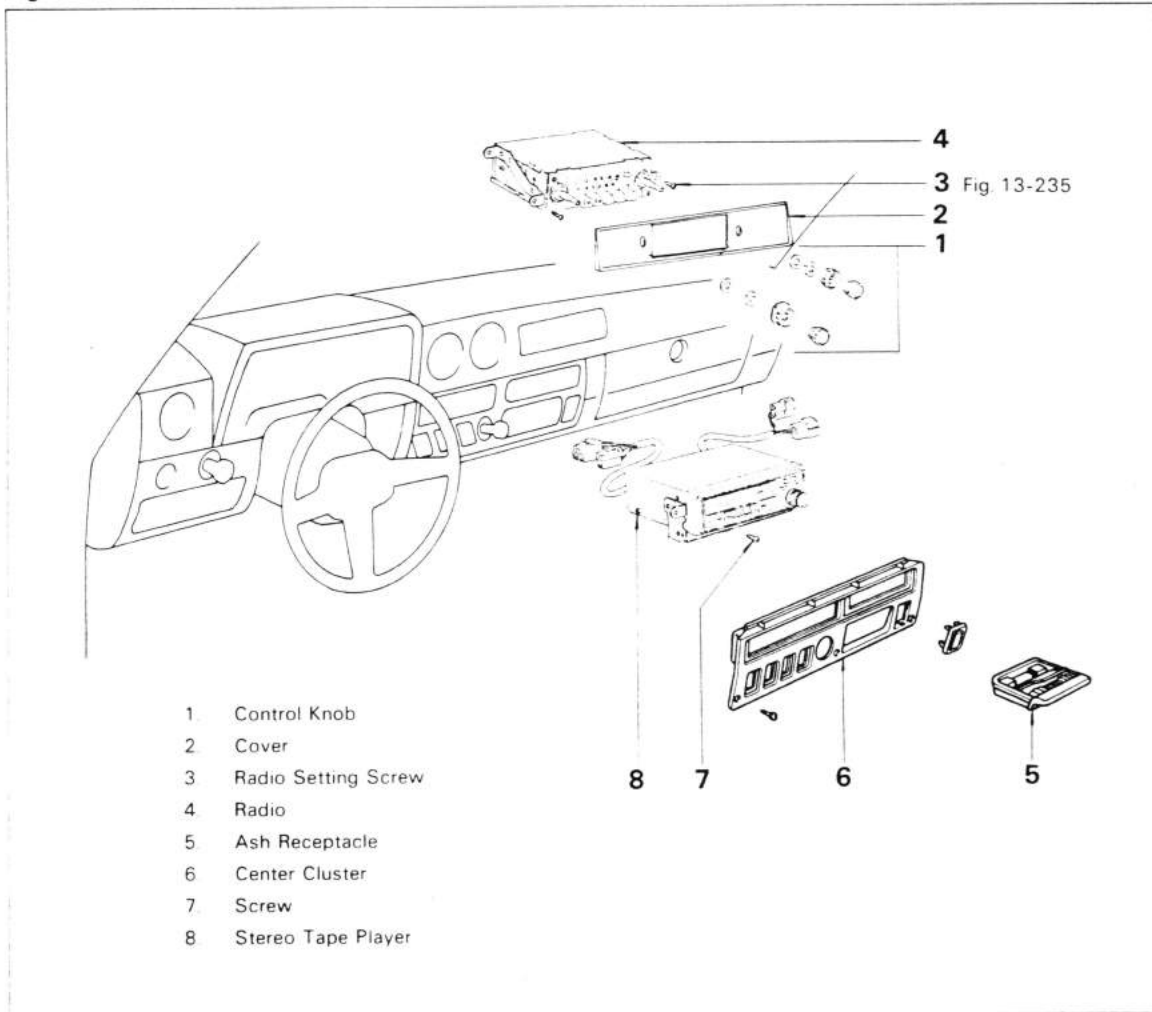
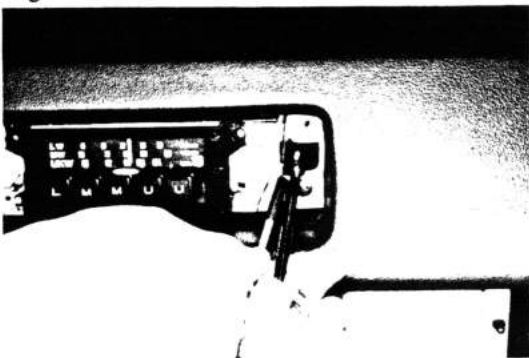

Fig. 13-235



Hold the screw with the magnet

INSTALLATION

Install the parts in the numerical order shown in the figure.

Fig. 13-236

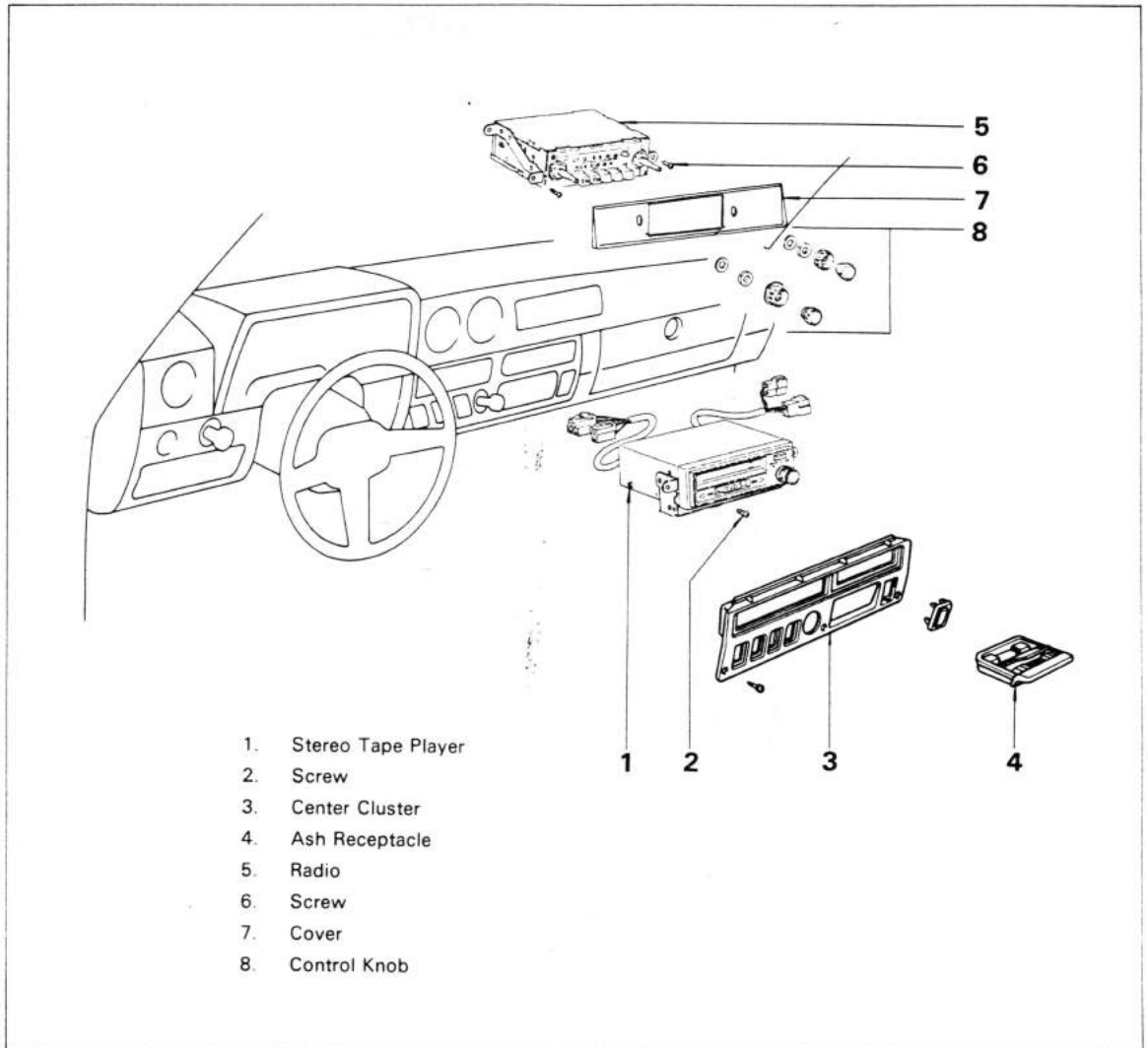
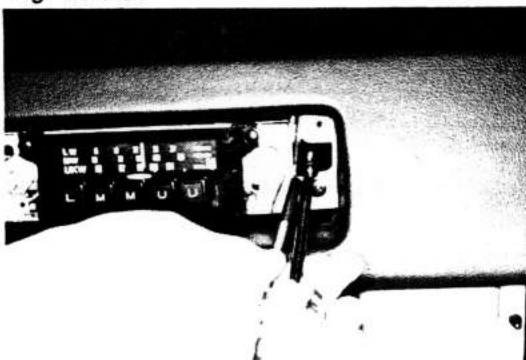

Fig. 13-237



Screw in the screw while holding the it with magnet.

ANTENNA

REMOVAL

Remove the parts in the numerical order shown in the figure.

Fig. 13-238

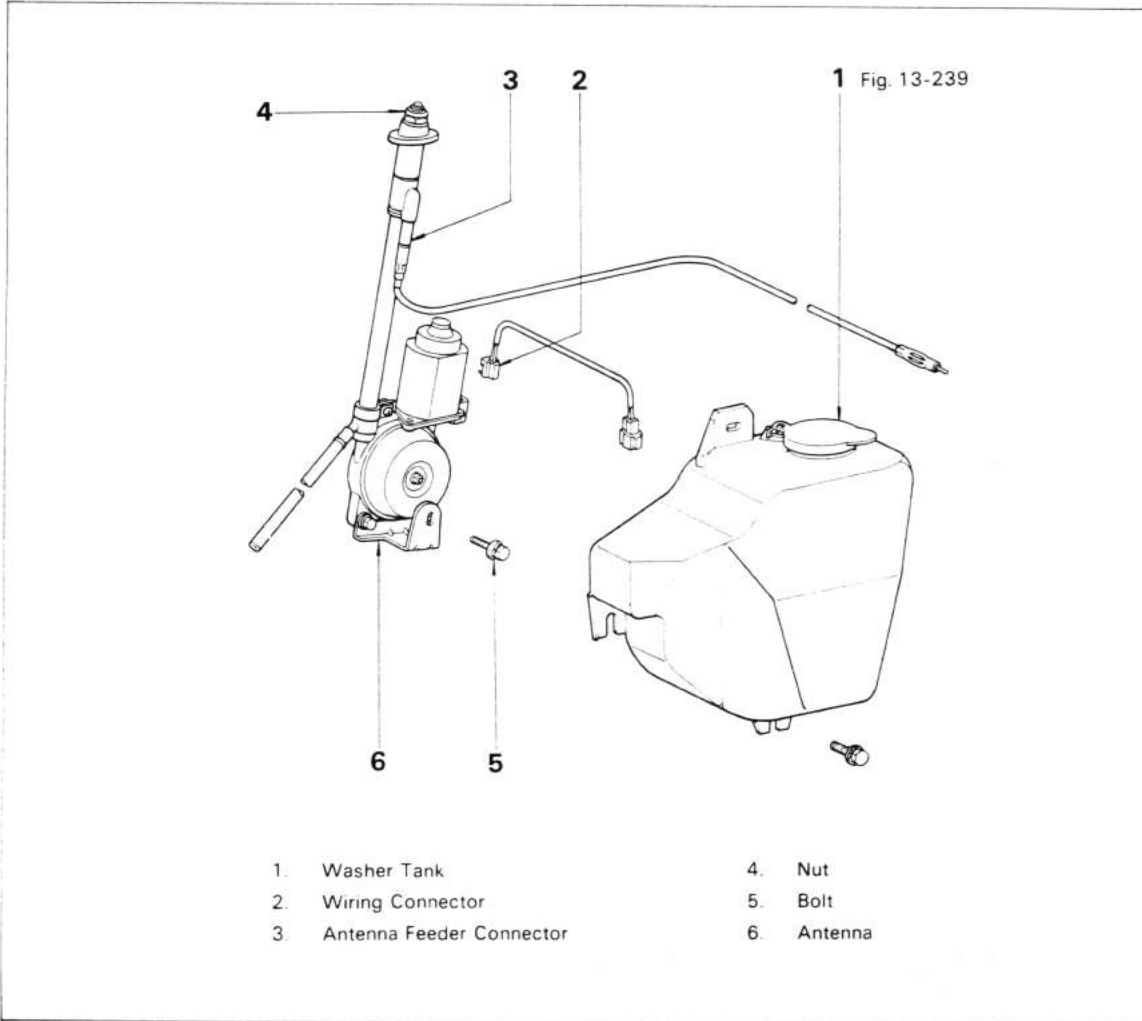

Fig. 13-239



After removing the washer tank, lower bracket bolt.

Fig. 13-240



Fig. 13-241

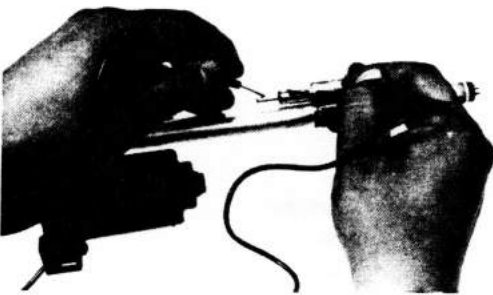

Fig. 13-242

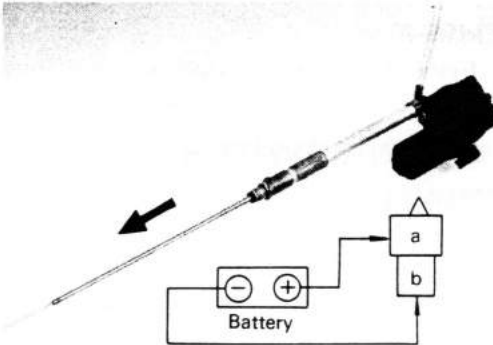
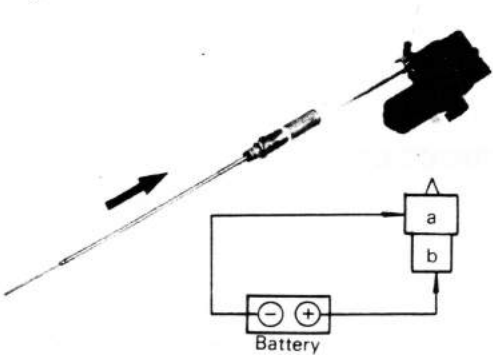

Fig. 13-243



INSPECTION



- 1 Check the continuity between antenna plug and pole tip.
If there is a continuity between both ends, the cord is good condition.



2. Check the continuity between connector core and body.
If there is not a continuity between both ends, the condition is good condition.



3. The antenna pole should be extended when apply the battery voltage to the terminals.



4. The antenna pole should be shortened when apply the battery voltage to the terminals.

INSTALLATION

Install the parts in the numerical order shown in the figure.

Fig. 13-244

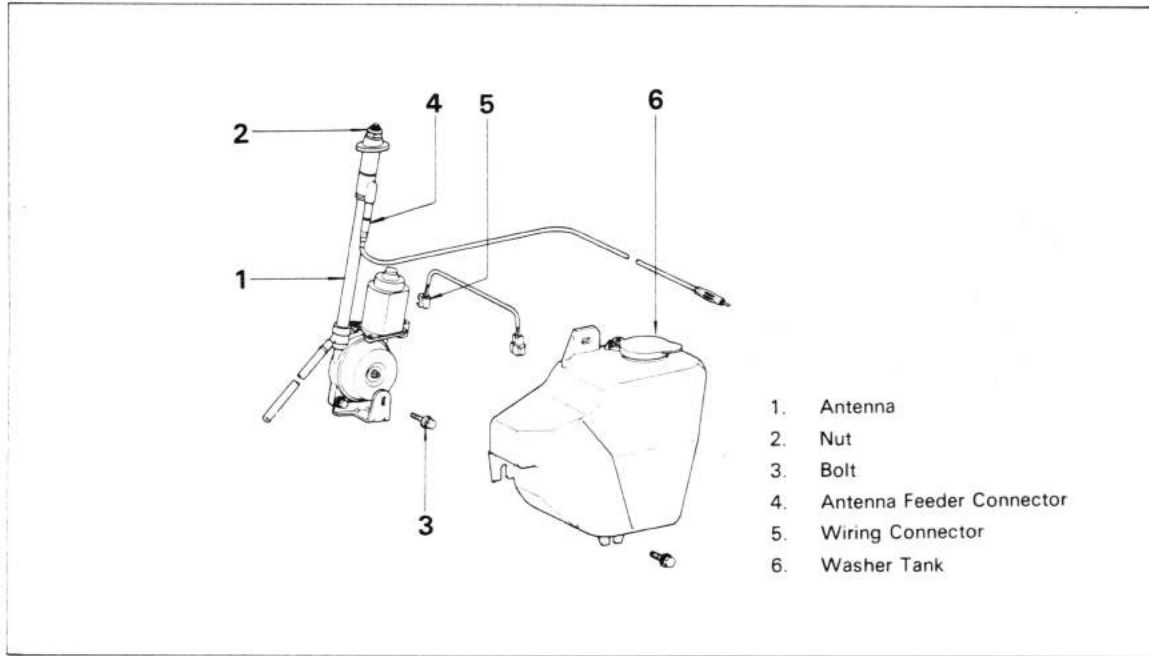

- 1. Antenna
- 2. Nut
- 3. Bolt
- 4. Antenna Feeder Connector
- 5. Wiring Connector
- 6. Washer Tank

Fig. 13-245



**ANTENNA SWITCH
REMOVAL**

1. Remove the center panel.
2. Disconnect the connector.
3. Remove the switch by prying its.

Fig. 13-246

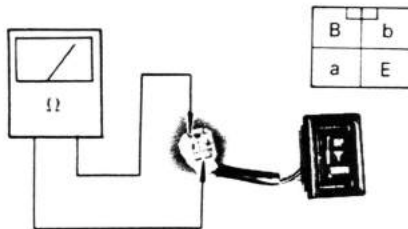

INSPECTION

Check the each terminals continuity.

Terminal Position	B	E	a	b
UP	○	○	○	○
DOWN	○	○	○	○

Fig. 13-247

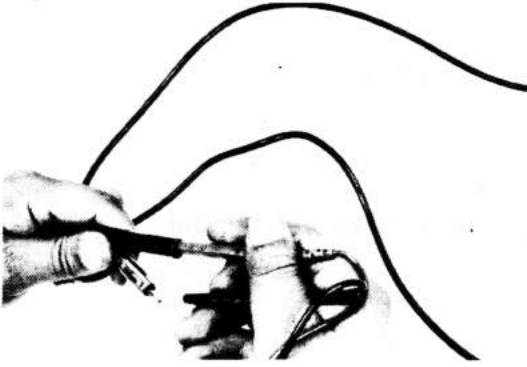
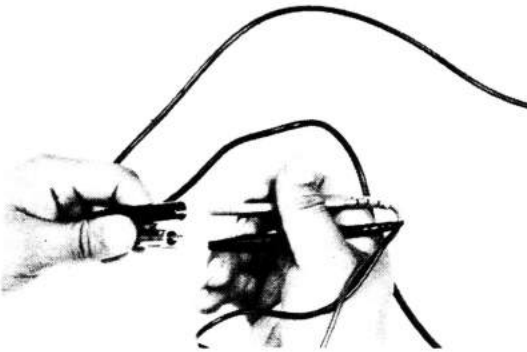

Fig. 13-248

**ANTENNA FEEDER****INSPECTION**





1. Check the continuity between core cord. If there is a continuity between both ends, the core cord is good condition.



2. Check the continuity between sealed cord. If there is a continuity between both ends, the sealed cord is good condition.

TROUBLESHOOTING (RADIO)

1. Description of symbols

	... Inspection item	Example: [WH] For the connector, refer to the wiring diagram and check for short circuit or open circuit. Also check the connector for separation or improper contact.
	... Check or replace part	
	... Pass if not necessary	
 Adjust	
 Test by operating radio	
[WH] Wire harness	

2. Dead radio

(1) No noise whatever

Cause:

1. Blown radio fuse
2. Disconnected power source connector
3. Blown main fuse
4. Broken speaker wire or disconnected connector
5. Defective radio

Fig. 13-249

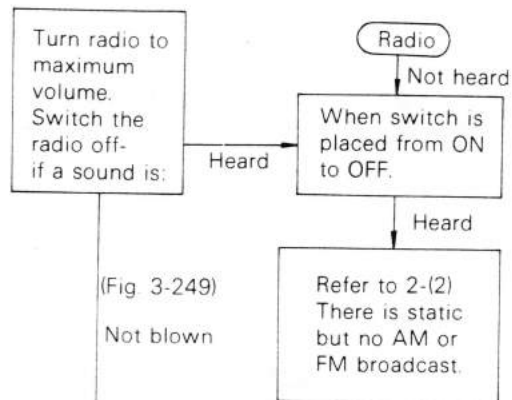
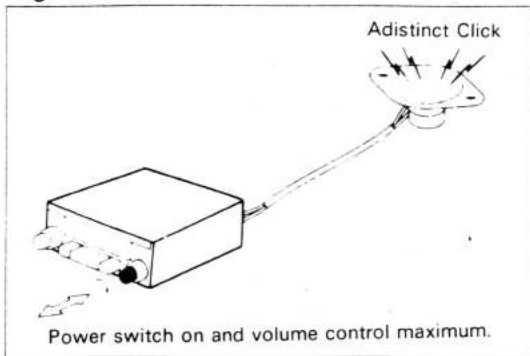

Fig. 13-250

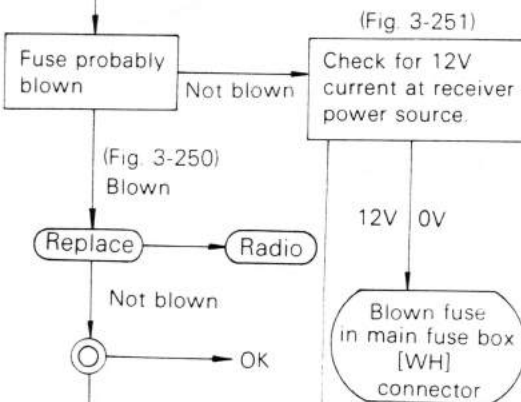

Fig. 13-251

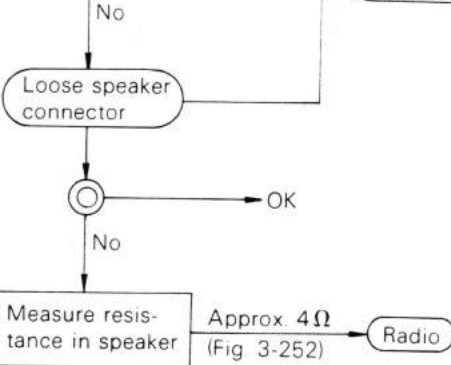
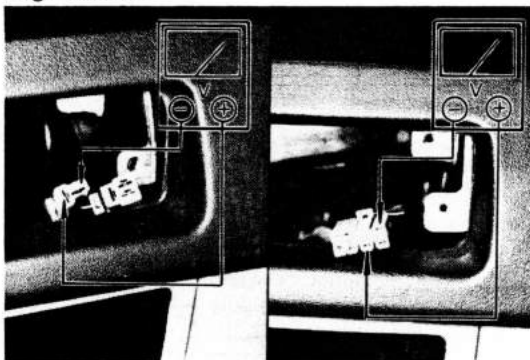
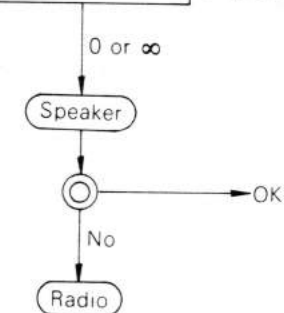
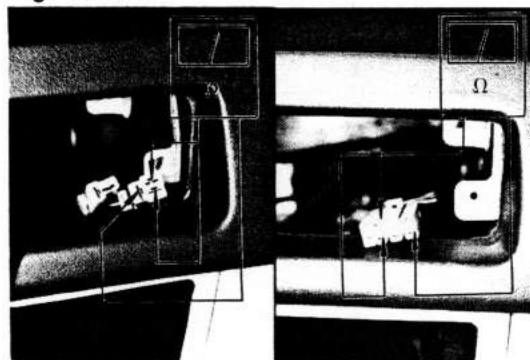

Fig. 13-252



— Reference —

A steady hum may come from the transistor, resistor, condenser and coils of a radio.

cardiagn.com

Fig. 13-253

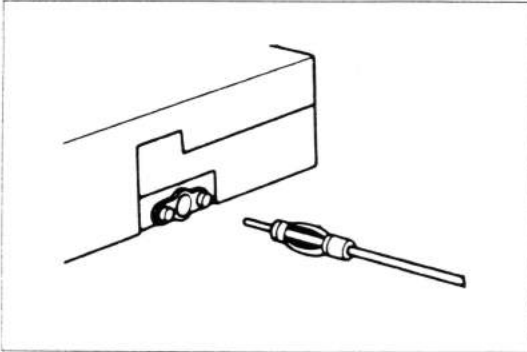

(2) Only static — No AM or FM reception.

Cause:

1. Disconnection or improper contact of antenna plug
2. Broken antenna wire
3. Defective antenna

Fig. 13-254

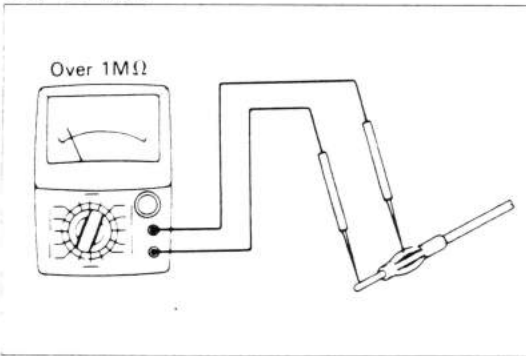

Can receive AM with the antenna at full length and volume at maximum. A piece of metal touched to the antenna causes a grating sound.

Yes → Radio

No

Remove radio

Check to see if antenna plug is loose or disconnected.

Problem → Antenna plug

(Fig. 3-253)

No problem

Check resistance between antenna plug and ground. Over or under $1M\Omega$

Under → Antenna

(Fig. 3-254)

Over

Check resistance between antenna plug tip and pole tip. Over or under 5Ω

Under → Radio

(Fig. 3-255)

Over

Antenna

No → Radio

OK

Fig. 13-255

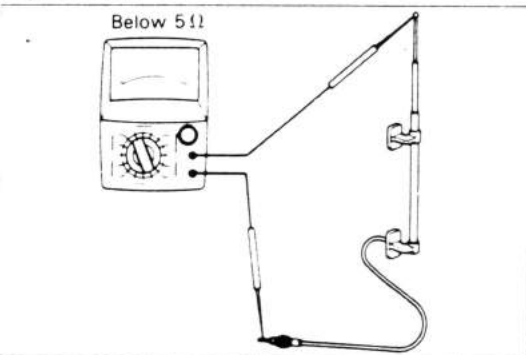

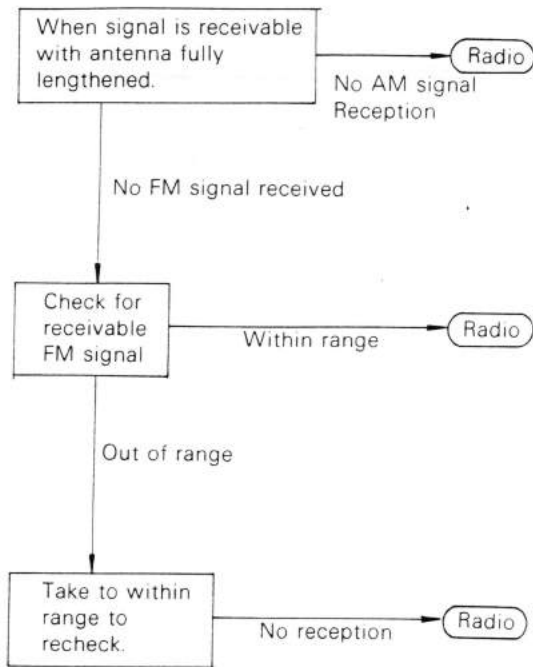

3. No Reception of either AM and FM (If antenna is for both AM and FM)

Cause:

1. If there is no AM reception, radio receiver is defective.
2. If there is no FM reception, radio receiver is defective or there is no receivable FM signal in the area.

— Reference —

The range is the maximum radius wherein of a radio signal can be received. FM range is limited, the signal rapidly decreasing at its maximum range. FM signal is also line of sight so there are valleys behind tall buildings, mountains. In this respect, FM is similar to television.

4. Faint reception

Cause:

1. Improper adjustment of antenna trimmer.
2. Defective antenna
3. Defective speaker
4. Defective radio receiver

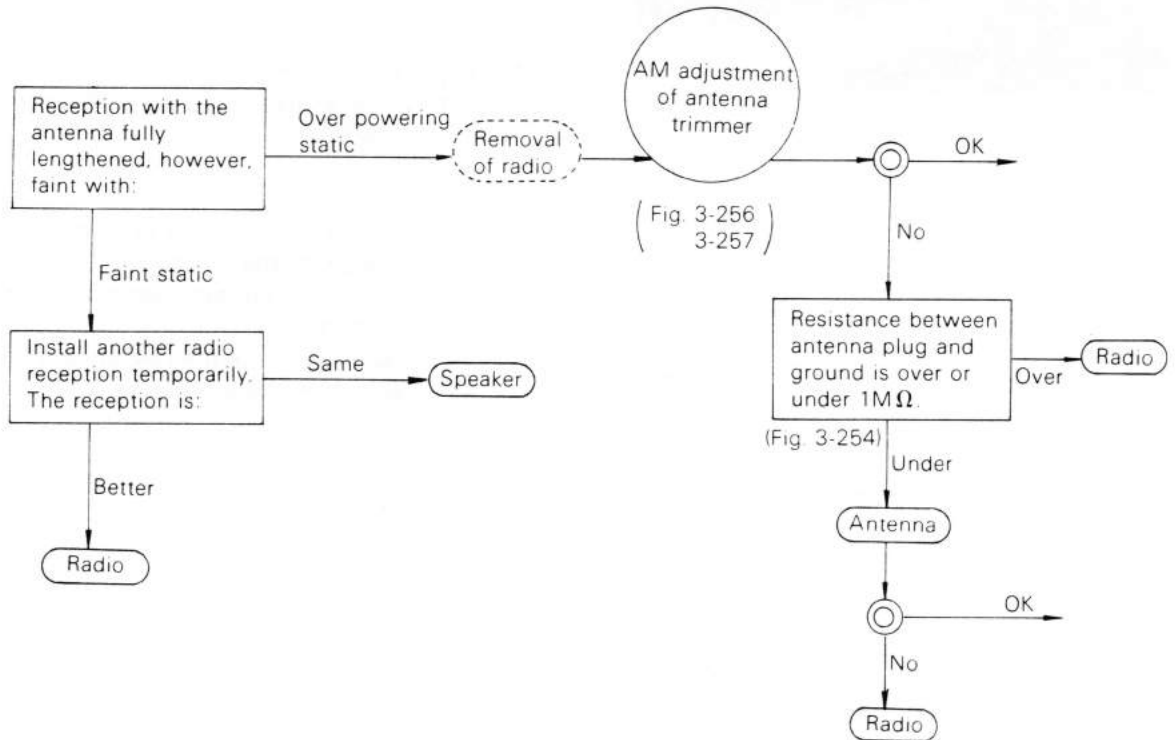

cardiagn.com

Fig. 13-256

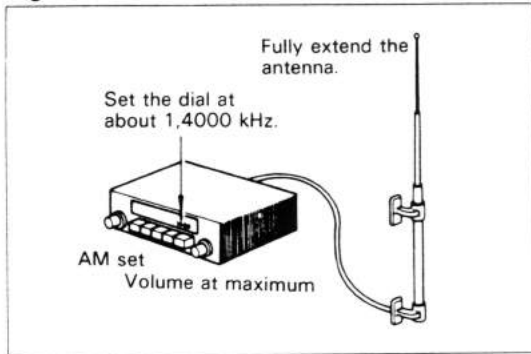

1. Fully extend the antenna.
2. Set the dial at about 1,400 kHz, volume at maximum.

Fig. 13-257

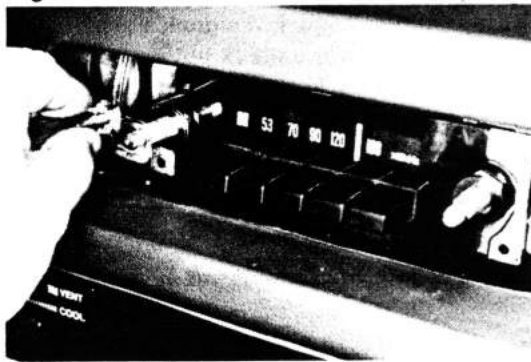

3. Adjust the antenna trimmer so that the radio hum is loudest.

5. Hum is irregular

(1) Hum is irregular on AM or on AM/FM

Cause:

1. Broken speaker cone paper or foreign matter is lodged next to it
2. Speaker voice coil and magnet in contact
3. Excessive antenna power input
4. Defective radio receiver

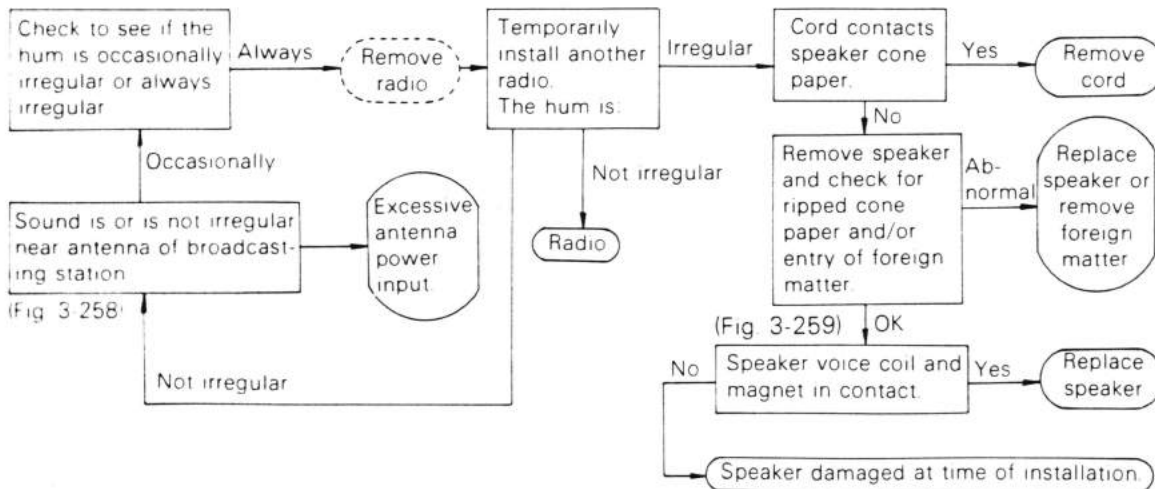
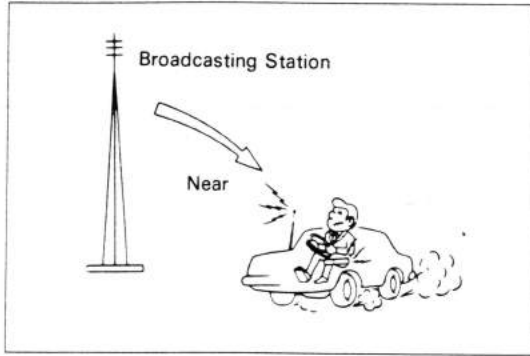

Fig. 13-258



— Reference —

Near a broadcasting station the sound on any radio becomes irregular because of excessive signal power. This cannot be avoided in most cases.

Fig. 13-259

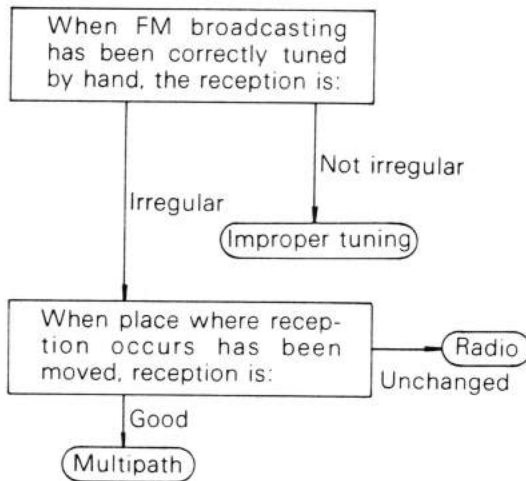

(2) Sound is irregular on FM only

Cause:

1. Improper tuning
2. Defective radio receiver

— Reference —

1. **Multipath is a multiple reflection.** Signals from the broadcasting station antenna reach the receiving antenna after having been reflected by buildings or mountains as well as by direct contact. They interfere with each other. However multipath changes over time or by moving the place or reception. With multipath reception, voice endings are unnatural.
2. **With FM, improper tuning results in irregular sound.** Pay special attention to tuning.