

AUTOMATIC TRANSMISSION

	Page
THOUBLESHOOTING	AT-2
ATF INSPECTION	AT-4
ADJUSTMENTS	AT-4
TESTS	AT-5
AUTOMATIC SHIFT DIAGRAM	AT-13
ELECTRIC CONTROL	AT-14
ON-VEHICLE REPAIR	AT-19
REMOVAL OF TRANSMISSION (2WD)	AT-30
REMOVAL OF TRANSMISSION (4WD)	AT-33
DISASSEMBLY OF TRANSMISSION	AT-37
COMPONENT GROUP DISASSEMBLY, INSPECTION AND ASSEMBLY	AT-43
Oil pump	AT-44
Overdrive Input Shaft and Clutch	AT-47
Overdrive Case and Brake	AT-52
Front Clutch	AT-55
Rear Clutch	AT-59
Center Support Assembly	AT-62
Planetary Gear Output Shaft	AT-68
Transmission Case and Rear Brake Pistons	AT-73
Valve Body	AT-76
Governor Body	AT-99
Extension Housing (2WD)	AT-101
Torque Converter	AT-101
Electrical Parts	AT-102
ASSEMBLY OF TRANSMISSION	AT-103
INSTALLATION OF TRANSMISSION (2WD)	AT-114
INSTALLATION OF TRANSMISSION (4WD)	AT-118

 AT

TROUBLESHOOTING

Problem	Possible cause	Remedy	Page
Fluid discolored or smells burnt	Fluid contaminated	Replace fluid	MA-11
	Torque converter faulty Transmission faulty	Replace torque converter Disassemble and inspect transmission	AT-37
Vehicle does not move in any forward range or reverse	Manual shift cable out of adjustment	Adjust shift cable	AT-4
	Valve body or primary regulator faulty	Inspect valve body	AT-19, 76
	Parking lock pawl faulty	Inspect parking lock pawl	AT-23
	Torque converter faulty	Replace torque converter	AT-114, 118
	Converter drive plate broken Oil pump intake strainer blocked	Replace drive plate Clean strainer	AT-19
Shift lever position incorrect	Manual shift cable out of adjustment	Adjust shift cable	AT-4
	Manual valve and lever faulty	Inspect valve body	AT-19, 76
	Transmission faulty	Disassemble and inspect transmission	AT-37
Harsh engagement into any drive range	Throttle cable out of adjustment	Adjust throttle cable	AT-4
	Valve body or primary regulator faulty	Inspect valve body	AT-19, 76
	Accumulator pistons faulty	Inspect accumulator pistons	AT-110
	Transmission faulty	Disassemble and inspect transmission	AT-37
Delayed 1-2, 2-3 or 3-OD up-shift, or down-shifts from OD-3 or 3-2 then shifts back to OD or 3	Throttle cable out of adjustment	Adjust throttle cable	AT-4
	Throttle cable and cam faulty	Inspect throttle cable and cam	AT-22
	Governor faulty	Inspect governor	AT-99
	Valve body faulty	Inspect valve body	AT-29, 76
Slips on 1-2, 2-3 or 3-OD up-shift, or slips or shudders on take-off	Manual shift cable out of adjustment	Adjust shift cable	AT-4
	Throttle cable out of adjustment	Adjust throttle cable	AT-4
	Valve body faulty	Inspect valve body	AT-19, 76
	Transmission faulty	Disassemble and inspect transmission	AT-37
Drag, binding or tie-up on 1-2, 2-3 or 3-OD up-shift	Manual shift cable out of adjustment	Adjust shift cable	AT-4
	Valve body faulty	Inspect valve body	AT-19, 76
	Transmission faulty	Disassemble and inspect transmission	AT-37

TROUBLESHOOTING (Cont'd)

Problem	Possible cause	Remedy	Page
Harsh down-shift	Throttle cable out of adjustment	Adjust throttle cable	AT-4
	Throttle cable and cam faulty	Inspect throttle cable and cam	AT-22
	Accumulator pistons faulty	Inspect accumulator pistons	AT-110
	Valve body faulty	Inspect valve body	AT-19, 76
	Transmission faulty	Disassemble and inspect transmission	AT-37
No down-shift when coasting	Governor faulty	Inspect governor	AT-99
	Valve body faulty	Inspect valve body	AT-19, 76
Down-shift occurs too quick or too late while coasting	Throttle cable out of adjustment	Adjust throttle cable	AT-4
	Throttle cable faulty	Inspect throttle cable	AT-22
	Governor faulty	Inspect governor	AT-99
	Valve body faulty	Inspect valve body	AT-19, 76
	Transmission faulty	Disassemble and inspect transmission	AT-37
OD-3, 3-2 or 2-1 kick-down	Throttle cable out of adjustment	Adjust throttle cable	AT-4
	Governor faulty	Inspect governor	AT-99
	Valve body faulty	Inspect valve body	AT-19, 76
No engine braking in "2" range	Valve body faulty	Inspect valve body	AT-19, 76
	Transmission faulty	Disassemble and inspect transmission	AT-37
Vehicle does not hold in "P"	Manual shift cable out of adjustment	Adjust shift cable	AT-4
	Parking lock pawl cam and spring faulty	Inspect cam and spring	AT-23

NOTE: See page AT-14 for inspection procedures for electrical controls of automatic transmission with overdrive.

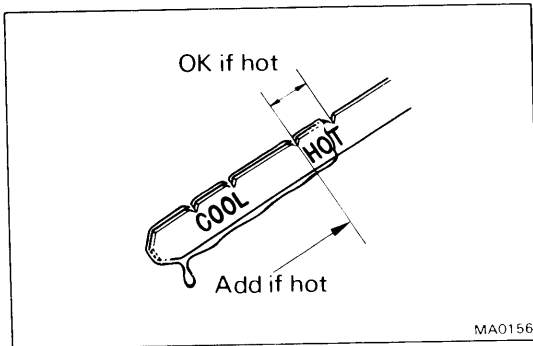

ATF INSPECTION

1. CHECK FLUID LEVEL (See page MA-15)
2. CHECK FLUID CONDITION
If the ATF smells burnt or is black, replace it.
3. REPLACE ATF (See page MA-12)

ADJUSTMENTS

ADJUSTMENT OF THROTTLE CABLE

1. DEPRESS ACCELERATOR PEDAL ALL THE WAY AND CHECK THAT THROTTLE VALVE OPENS FULLY
If the throttle valve does not open fully, adjust the accelerator link.

2. FULLY DEPRESS ACCELERATOR

3. LOOSEN ADJUSTING NUTS

4. ADJUST THROTTLE CABLE

- (a) Adjust the cable housing so that the distance between the end of the boot and the stopper on the cable is correct.

Distance: 0 – 1 mm (0 – 0.04 in.)

- (b) Tighten the adjusting nuts.
- (c) Recheck the adjustments.

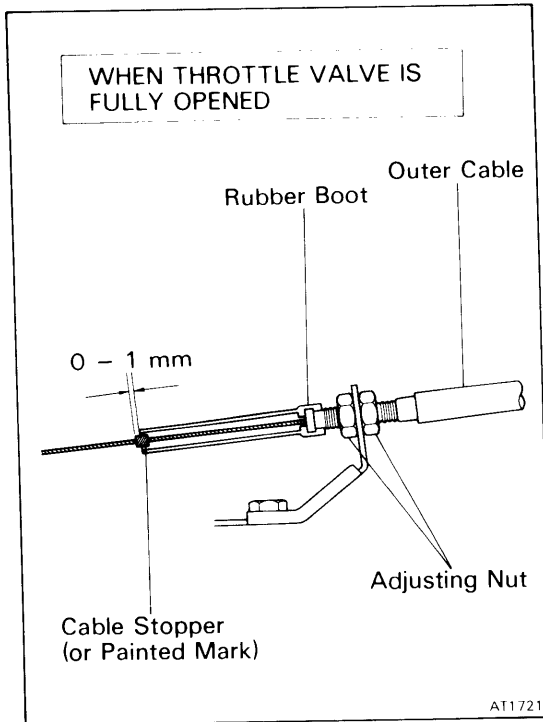

ADJUSTMENT OF FLOOR SHIFT CABLE

1. LOOSEN NUT ON SHIFT CABLE

2. ADJUST SHIFT CABLE

- (a) Push the manual lever fully rearward.
- (b) Return the lever two notches to the NEUTRAL position.
- (c) Set the shift selector in "N".
- (d) While holding the selector lightly toward the "R" range side, tighten the shift cable nut.

ADJUSTMENT OF NEUTRAL START SWITCH

If the engine will start with the shift selector in any range other than "N" or "P", adjustment is required.

1. LOOSEN NEUTRAL START SWITCH BOLT AND SET SHIFT SELECTOR IN "N" RANGE

2. ADJUST NEUTRAL START SWITCH

- (a) Align the groove and neutral basic line.
- (b) Hold in position and tighten the bolt.

3. TORQUE NEUTRAL START SWITCH BOLT

Torque: 55 kg-cm (48 in.-lb, 5.4 N-m)

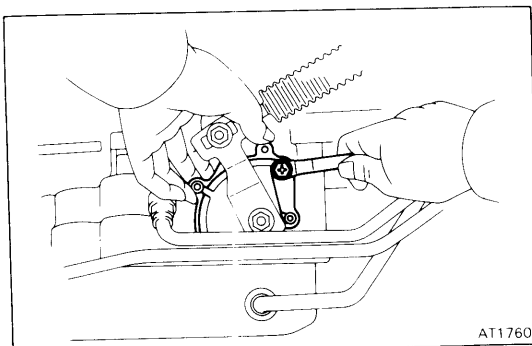
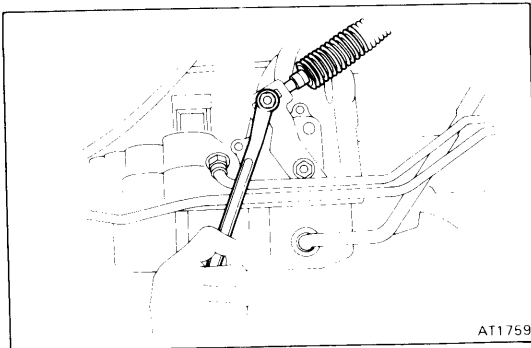

TESTS

STALL TEST

The object of this test is to check the overall performance of the transmission and engine by measuring the maximum engine speeds in the "D" and "R" ranges.

CAUTION:

- Perform the test at normal operation fluid temperature (50 – 80°C or 122 – 176°F).
- Do not continuously run this test longer than 5 seconds.

MEASURE STALL SPEED

- Chock the front wheels.
- Mount an engine tachometer.
- Fully apply the parking brake.
- Step down strongly on the brake pedal with your left foot.
- Start the engine.
- [4WD]
Turn off the 4WD control switch.
- Shift into "D" range. Step all the way down on the accelerator pedal with your right foot. Quickly read the highest engine rpm at this time.

Stall speed: 2,100 ± 150 rpm

- Perform the same test in "R" range.

EVALUATION

- If the engine speed is the same for both ranges but lower than specified value:
 - Engine output is insufficient.
 - Stator one-way clutch is not operating properly.

NOTE: If more than 600 rpm below the specified value, the torque converter could be faulty.

- If the stall speed in "D" range is higher than specified:
 - Line pressure too low
 - Front clutch slipping
 - One-way clutch No. 2 not operating properly
 - OD one-way clutch not operating properly
- If the stall speed in "R" range is higher than specified:
 - Line pressure too low
 - Rear clutch slipping
 - Brake No. 3 slipping
 - OD one-way clutch not operating properly
- If the stall speed at "R" and "D" range is higher than specified:
 - Line pressure too low
 - Improper fluid level
 - OD one-way clutch not operating properly

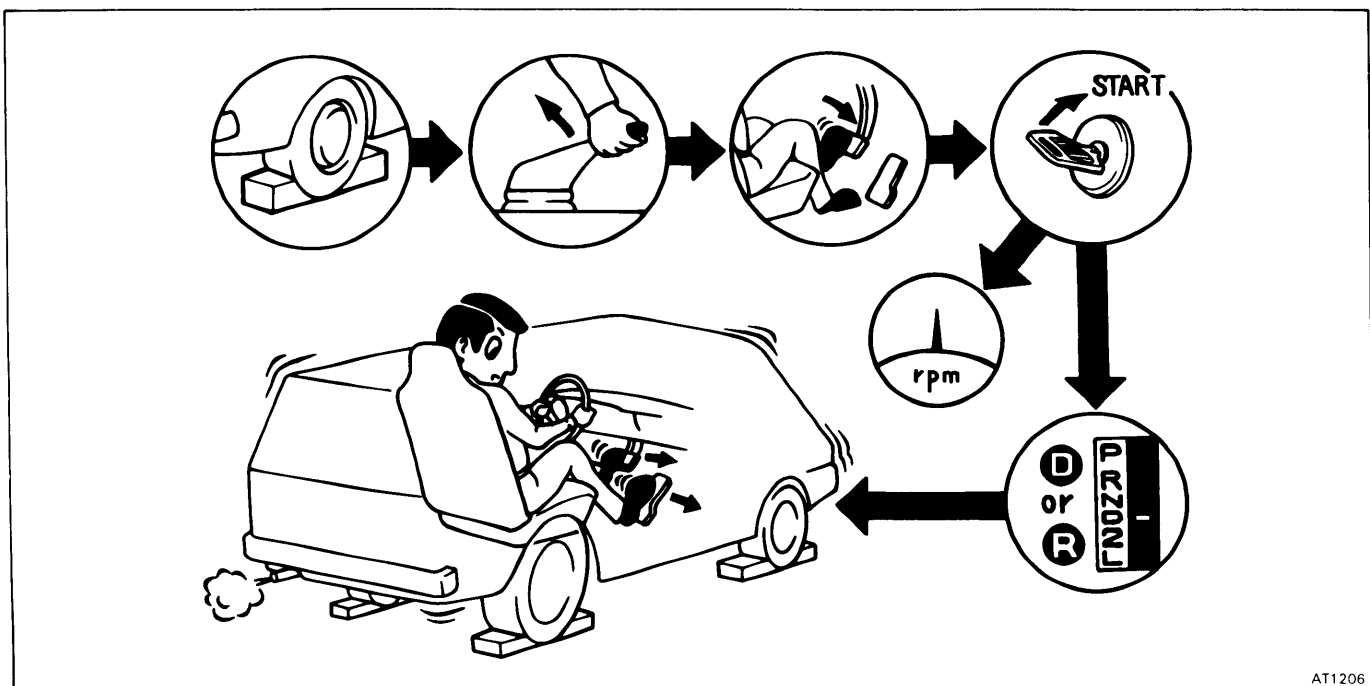

TIME LAG TEST

If the shift lever is shifted while the engine is idling, there will be a certain time lapse or lag before the shock can be felt. This is used for checking the condition of the OD clutch, front clutch, rear clutch and brake No. 3.

MEASURE TIME LAG

- Fully apply the parking brake.
- Start the engine and check the idle speed.

Idle speed: 750 rpm

- [4WD]
Turn off the 4WD control switch.
- Shift the shift lever from "N" to "D" range.
Using a stop watch, measure the time it takes from shifting the lever until the shock is felt.

Time lag: Less than 1.2 seconds

- In same manner, measure the time lag for "N" → "R".

Time lag: Less than 1.5 seconds

CAUTION:

- Perform the test at normal operation fluid temperature (50 — 80°C or 122 — 176°F).
- Be sure to allow one minute interval between tests.
- Make three measurements and take the average value.

EVALUATION

- If "N" → "D" time lag is longer than specified:
 - Line pressure too low
 - Front clutch worn
 - OD one-way clutch not operating properly
- If "N" → "R" time lag is longer than specified:
 - Line pressure too low
 - Rear clutch worn
 - Brake No. 3 worn
 - OD one-way clutch not operating properly

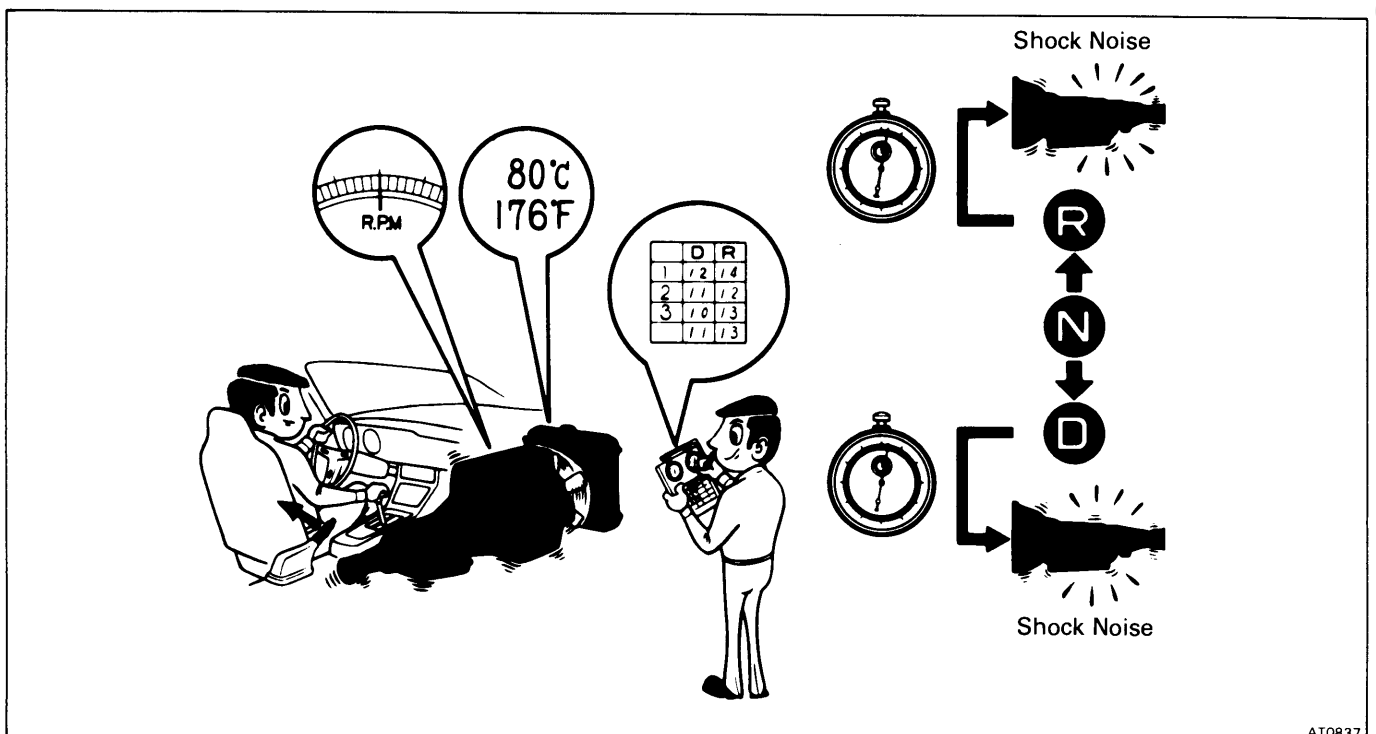

HYDRAULIC TEST

1. PREPARATION

- (a) Warm up the transmission fluid.
- (b) [4WD]
Turn off the 4WD control switch.
- (c) Chock the front wheels.
- (d) Jack up rear of the vehicle and support it on stands.
- (e) Remove the transmission case test plugs and mount hydraulic pressure gauges.

SST 09992-00093

CAUTION:

- (a) Perform the test at normal operation fluid temperature (50 – 80°C or 122 – 176°F).

- (b) Measurement can be made with the 1,000 rpm test, but if tests are to be made at 1,800 and 3,500 rpm, it would be safer to test on a road or chassis dynamometer because an onstand test could be hazardous.

2. MEASURE GOVERNOR PRESSURE

- (a) Fully apply the parking brake.
- (b) Start the engine.
- (c) Shift into “D” range and measure the governor pressures at the speeds specified in the table.

EVALUATION

If governor pressure is defective.

- Line pressure defective
- Fluid leakage in governor pressure circuit
- Governor valve operation defective

	Output shaft	Vehicle speed (Reference only)	Governor pressure
A45DL Tire size 175R14 Differential gear ratio 4,300	1,000 rpm	26 km/h (16 mph)	1.4 — 1.7 kg/cm ² (20 — 24 psi, 137 — 167 kpa)
	1,800 rpm	48 km/h (30 mph)	2.2 — 2.6 kg/cm ² (31 — 37 psi, 216 — 255 kpa)
	3,500 rpm	94 km/h (58 mph)	4.5 — 5.3 kg/cm ² (64 — 75 psi, 441 — 520 kpa)
A45DL Tire size P195/75R14 Differential gear ratio 4,300	1,000 rpm	27 km/h (17 mph)	1.4 — 1.7 kg/cm ² (20 — 24 psi, 137 — 167 kpa)
	1,800 rpm	50 km/h (31 mph)	2.2 — 2.6 kg/cm ² (31 — 37 psi, 216 — 255 kpa)
	3,500 rpm	91 km/h (57 mph)	4.5 — 5.3 kg/cm ² (64 — 75 psi, 441 — 520 kpa)
A45DF Tire size P205/75R14 Differential gear ratio 4,778	1,000 rpm	26 km/h (16 mph)	1.4 — 1.7 kg/cm ² (20 — 24 psi, 137 — 167 kpa)
	1,800 rpm	46 km/h (29 mph)	2.2 — 2.6 kg/cm ² (31 — 37 psi, 216 — 255 kpa)
	3,500 rpm	88 km/h (55 mph)	4.5 — 5.3 kg/cm ² (64 — 75 psi, 441 — 520 kpa)

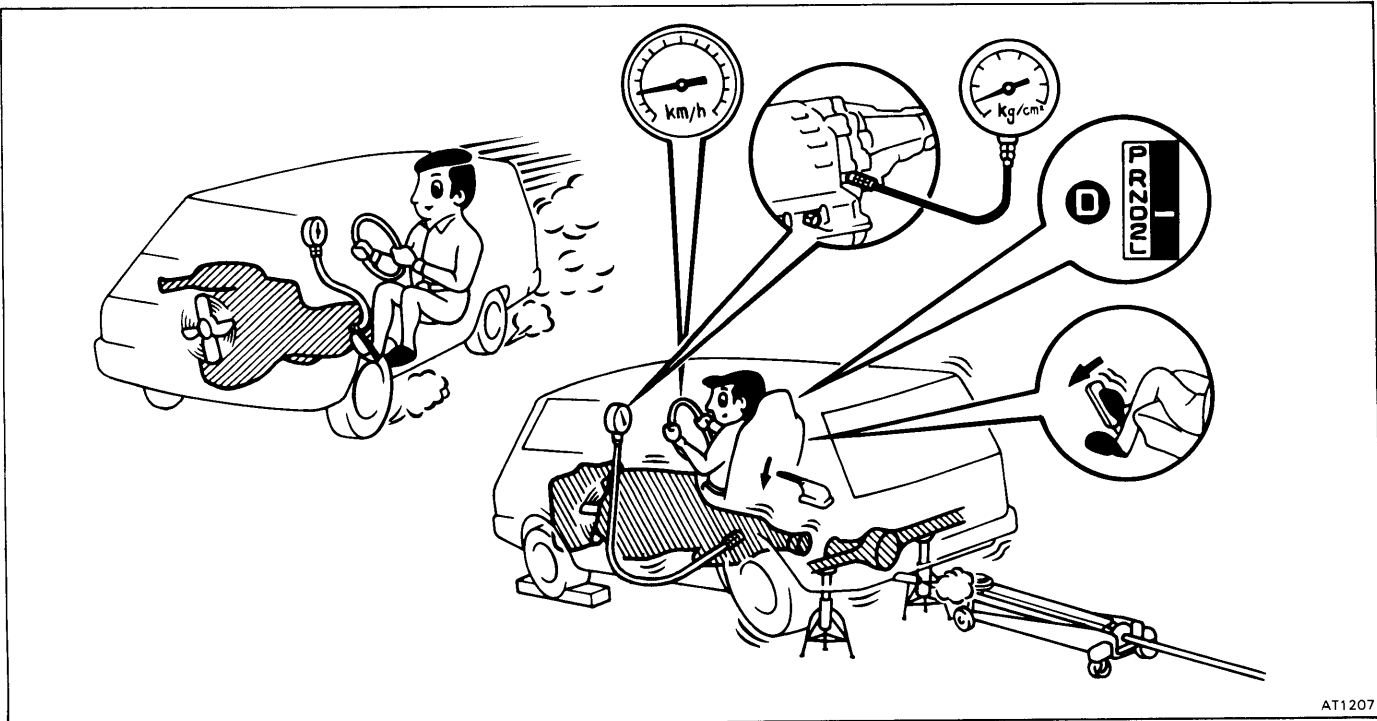

3. MEASURE LINE PRESSURE

- (a) Fully apply the parking brake and chock the four wheels.
- (b) Start the engine.
- (c) [4WD]
Turn off the 4WD control switch.
- (d) Shift into "D" range and step down strongly on the brake pedal with your left foot and, while manipulating the accelerator pedal with the right foot, measure the line pressures at the engine speeds specified in table.
- (e) In the same manner, perform the test in "R" range.

EVALUATION

- (a) If the measured values at all ranges are higher than specified:
 - Throttle cable out-of-adjustment
 - Throttle valve defective
 - Regulator valve defective
- (b) If the measured values at all ranges are lower than specified:
 - Throttle cable out-of-adjustment
 - Throttle valve defective
 - Regulator valve defective
 - Oil pump defective
 - OD clutch defective
- (c) If pressure is low in "D" range only:
 - "D" range circuit fluid leakage
 - Front clutch defective
 - OD clutch defective
- (d) If pressure is low in "R" range only:
 - "R" range circuit fluid leakage
 - Rear clutch defective
 - Brake No. 3 defective
 - OD clutch defective

Engine speed	Line pressure	
	"D" range	"R" range
Idling	4.5 – 5.1 (64 – 73) [441 – 500]	6.8 – 7.6 (97 – 108) [667 – 745]
Stall	10.1 – 11.9 (144 – 169) [990 – 1,167]	15.0 – 19.0 (213 – 270) [1,471 – 1,863]

- (f) If the measured pressures are not up to specified values, recheck the throttle cable adjustment and retest.

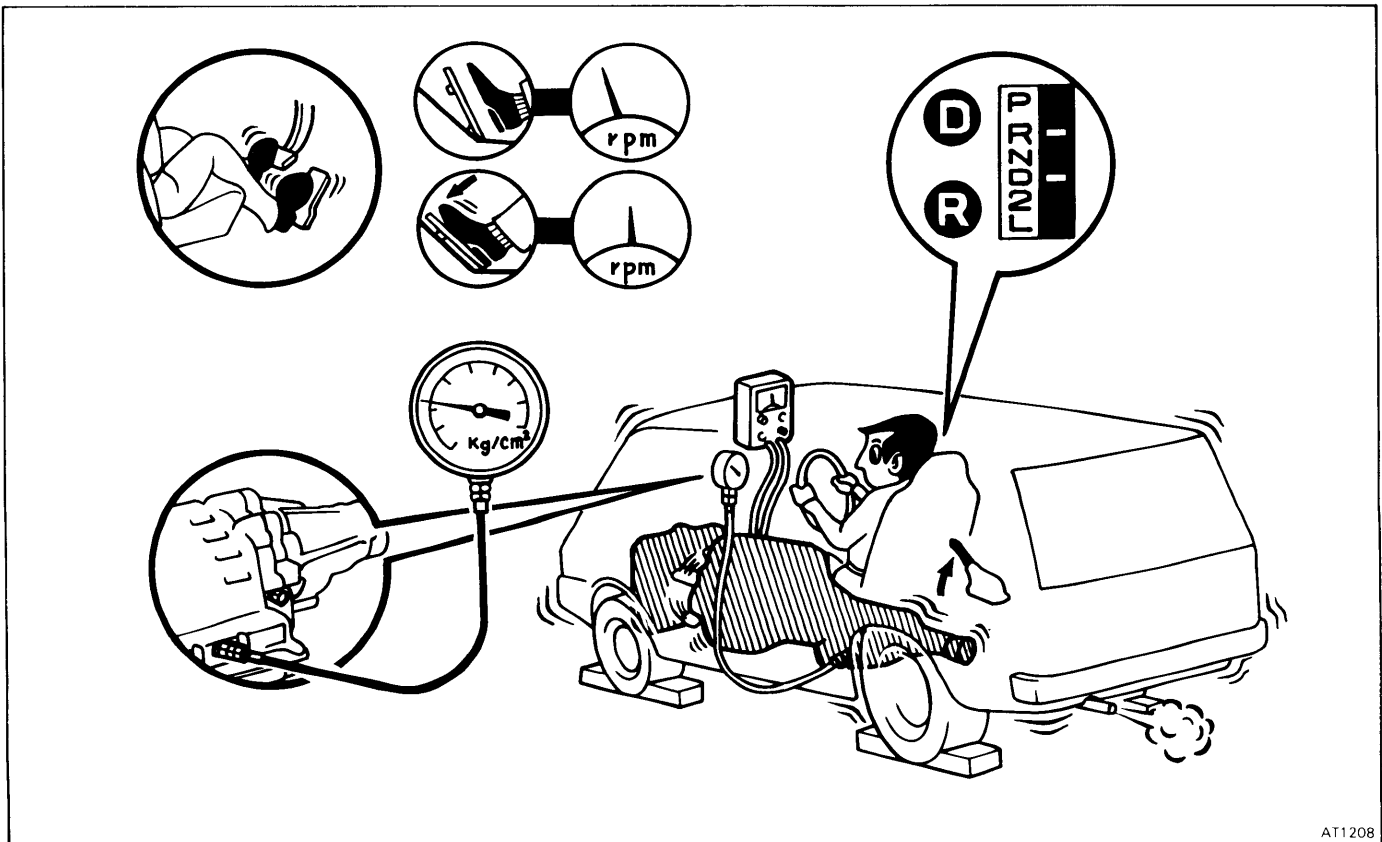

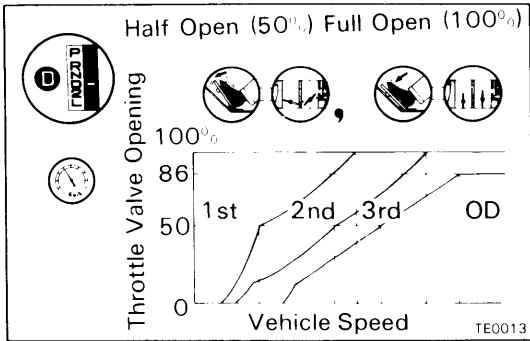

ROAD TEST

CAUTION: Perform the test at normal operation fluid temperature (50 – 80°C or 122 – 176°F).

1. "D" RANGE TEST

Shift into "D" range and, while driving with the accelerator pedal held constant at specified points (throttle valve opening 50% and 100%) and the OD switch "ON", check the following points.

- (a) At each of the above throttle openings, check to see that 1→2, 2→3 and 3→OD up-shift take place and also that the shift points conform to those shown in the automatic shift diagram.

NOTE: 3→OD up-shift does not take place with a throttle valve opening of more than 86% or coolant temperature below 50°C (122°F).

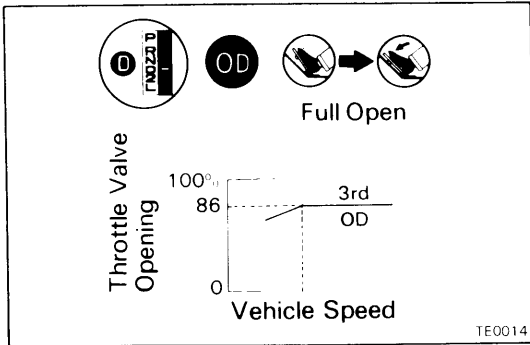

EVALUATION

- (1) If there is no 1→2 up-shift:
 - Governor valve is defective
 - 1-2 shift valve is stuck
- (2) If there is no 2→3 up-shift:
 - 2-3 shift valve is stuck
- (3) If there is no 3→OD up-shift (throttle valve opening of less than 86%):
 - 3-OD shift valve is stuck
- (4) If the shift point is defective:
 - Throttle cable is out-of-adjustment
 - Throttle valve, 1-2 shift valve, 2-3 shift valve, 3-OD shift valve etc., are defective

- (b) In the same manner, check the shock and the slip at 1→2, 2→3 and 3→OD up-shifts.

EVALUATION

If the shock is severe:

- Line pressure is too high
- Accumulator is defective
- Check ball is defective

- (c) In "D" range 3rd gear or OD, check for abnormal noise and vibration.

NOTE: Check for cause of abnormal noise and vibration must be made with extreme care as they could also be due to unbalance in propeller shaft, differential, tire, torque converter, etc. or insufficient bending rigidity, etc., in the power train.

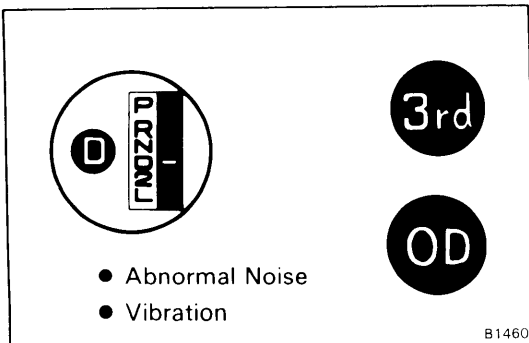
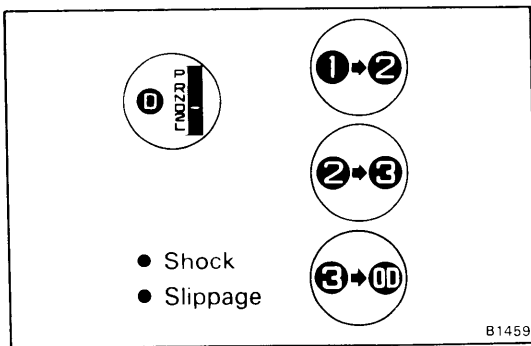

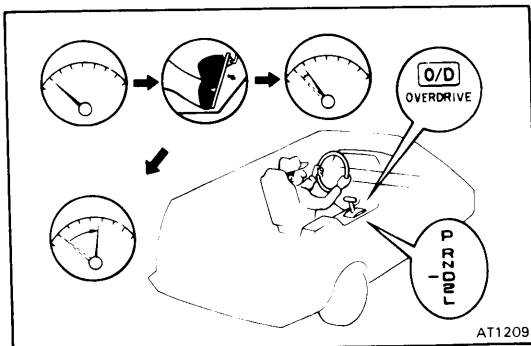
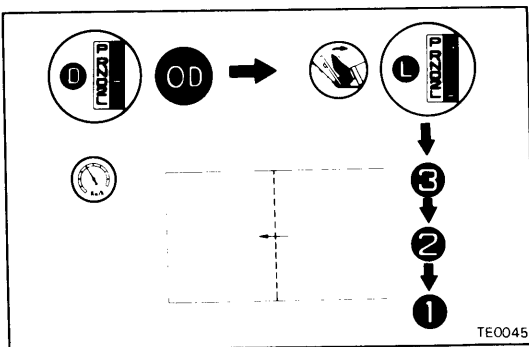
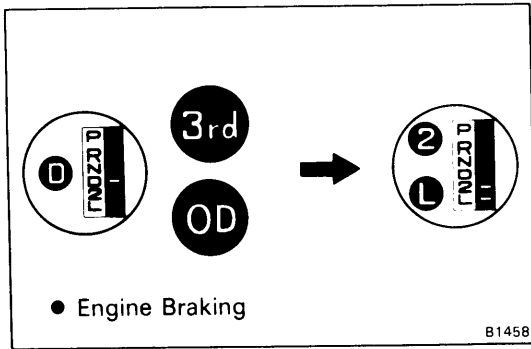
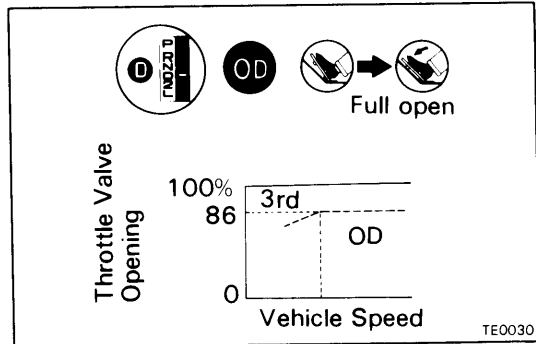
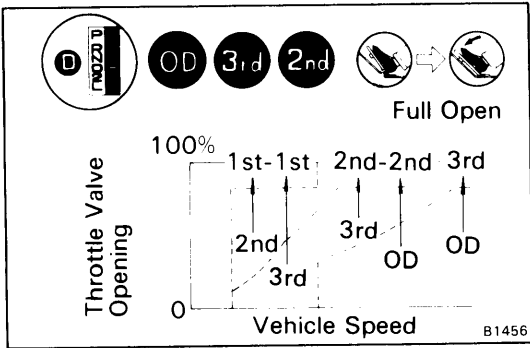

- (d) While running in "D" range 2nd, 3rd gears and OD, check to see that the possible kick-down vehicle speed limits for 2→1, 3→1, 3→2, OD→3 and OD→2 kick-downs conform to those indicated in the automatic shift diagram.
- (e) Check for abnormal shock and slip at kick-down.

NOTE: OD→3 kick-down is always possible with a throttle valve opening of more than 86%.

- (f) While running in "D" range 3rd gear or OD gear, shift to "2" and "L" ranges and check the engine braking effect in each of these ranges.

EVALUATION

- (1) If there is no engine braking effect in "2" range:
 - Brake No. 1 is defective
- (2) If there is no engine braking effect in "L" range:
 - Brake No. 3 is defective

- (g) While running in "D" range, release your foot from the accelerator pedal and shift into "L" range. Then check to see if OD→3, 3→2 and 2→1 down-shift points conform to those indicated in the automatic shift diagram.

- (h) While driving in "D" range, overdrive, at a steady speed (lock-up ON) of about 80 km/h (50 mph), lightly depress the accelerator pedal and check that the engine rpm does not change abruptly.

NOTE: If the lock-up is not operating, drive power will not be transmitted via the torque converter fluid. Consequently, the torque converter will slip when the pedal is depressed, causing an abrupt change in engine rpm.

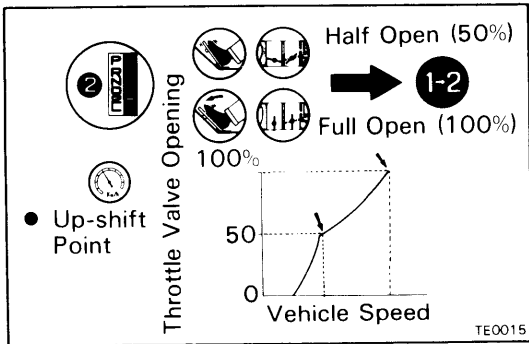

2. "2" RANGE TEST

(a) Shift to "2" range and run with the throttle valve opening at 50% and 100% respectively. Then check the 1→2 up-shift points at each of the throttle valve openings to see that it conforms to those indicated in the automatic shift diagram.

(b) While running in "2" range, 2nd gear, release the accelerator pedal and check the engine braking effect.

(c) Perform a kick-down from the "2" range and check the possible 2→1 kick-down vehicle speed limit to see if it conforms to that indicated in the automatic shift diagram.

(d) Check for abnormal noise at acceleration and deceleration, and for shock at up-shift and down-shift.

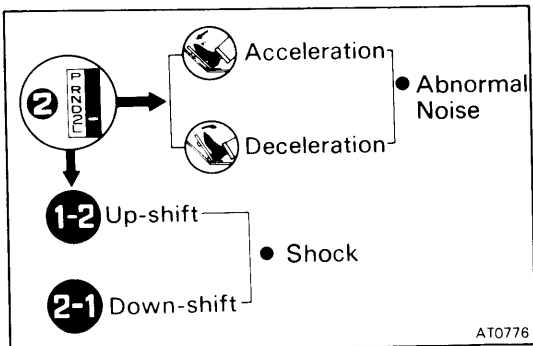
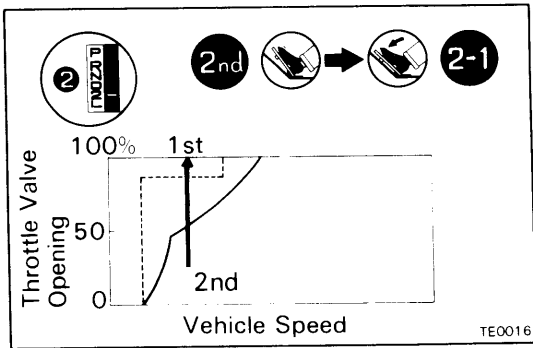
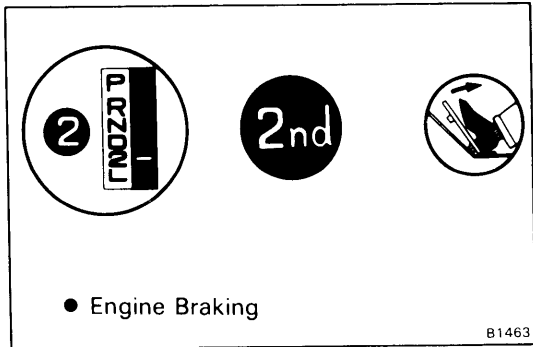

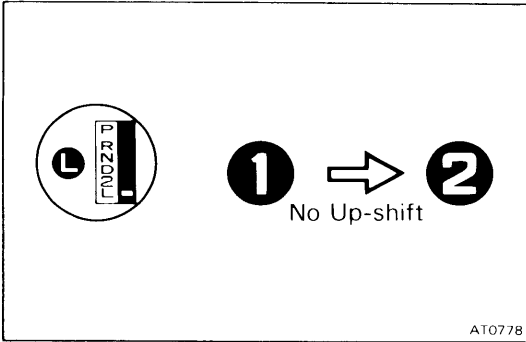

3. "L" RANGE TEST

(a) While running in "L" range, check to see that there is no up-shift to 2nd gear.

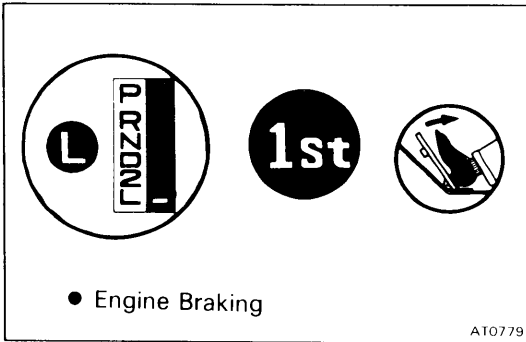

(b) While running in "L" range, release the accelerator pedal and check the engine braking effect.

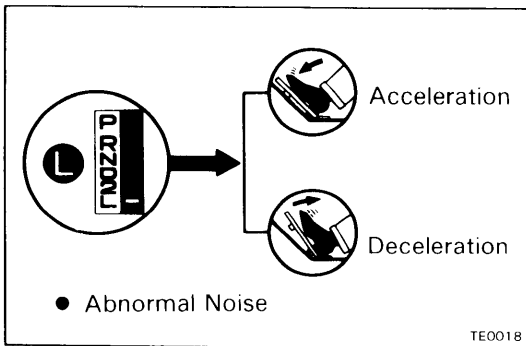

(c) Check for abnormal noise at acceleration and deceleration.

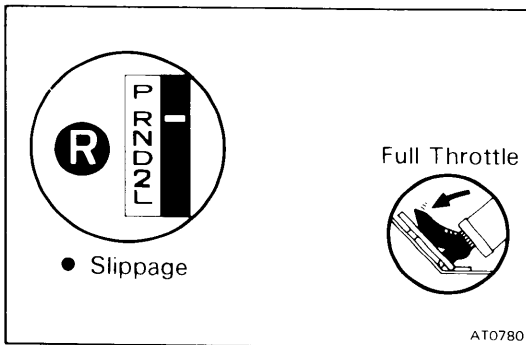

4. "R" RANGE TEST

Shift into "R" range and check for slipping while running at full throttle.

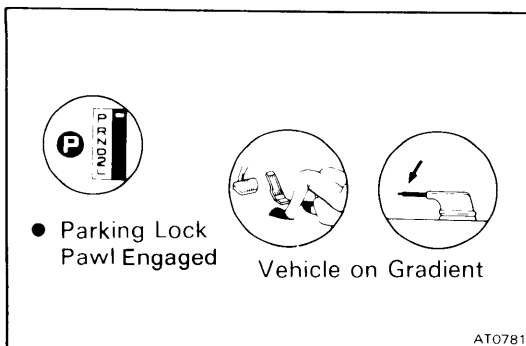

5. "P" RANGE TEST

Stop the vehicle on a gradient (more than 9%) and after shifting into "P" range, release the parking brake. Then check that the parking lock pawl prevents the vehicle from moving.

AUTOMATIC SHIFT DIAGRAM

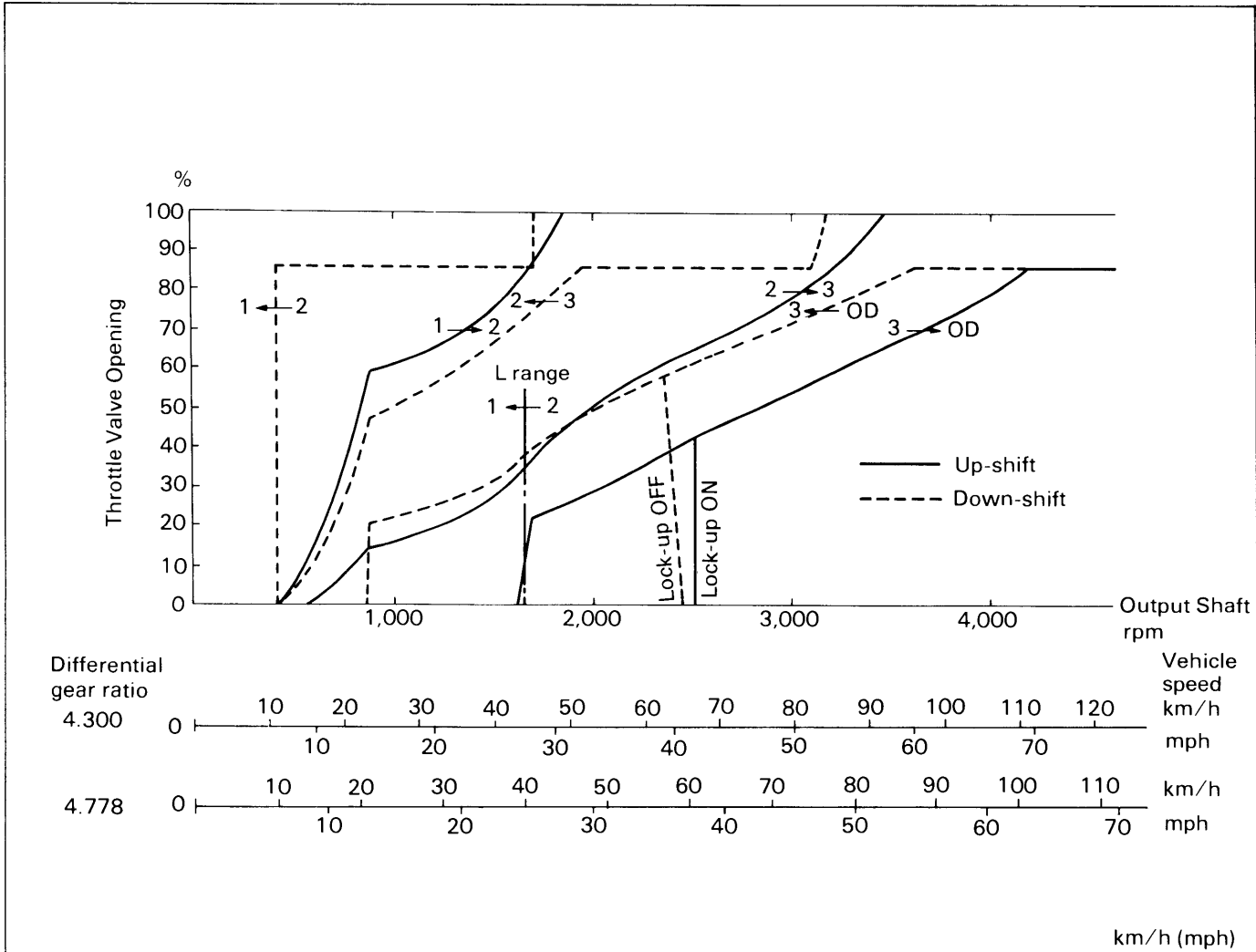

Differential gear ratio	"D" range (throttle valve fully open)							"L" range	
	1 → 2	2 → 3	3 → OD	Lock-up ON	Lock-up OFF	OD → 3	3 → 2	2 → 1	2 → 1
4.300	44-53 (27-33)	87-98 (54-61)	* ¹ 40-50 (25-31)	* ¹ 69-78 (43-48)	* ¹ 63-73 (39-45)	* ²	82-95 (51-59)	37-49 (23-30)	37-49 (23-30)
4.778	39-50 (24-31)	81-92 (50-57)	* ¹ 35-45 (22-28)	* ¹ 63-72 (39-45)	* ¹ 58-68 (36-42)	* ²	76-88 (47-55)	34-44 (21-27)	33-46 (21-29)

*¹ With closed throttle valve.

*² OD → 3 down shift possible up to maximum speed.

cardiagn.com

ELECTRIC CONTROL CIRCUIT (2WD)

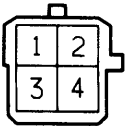
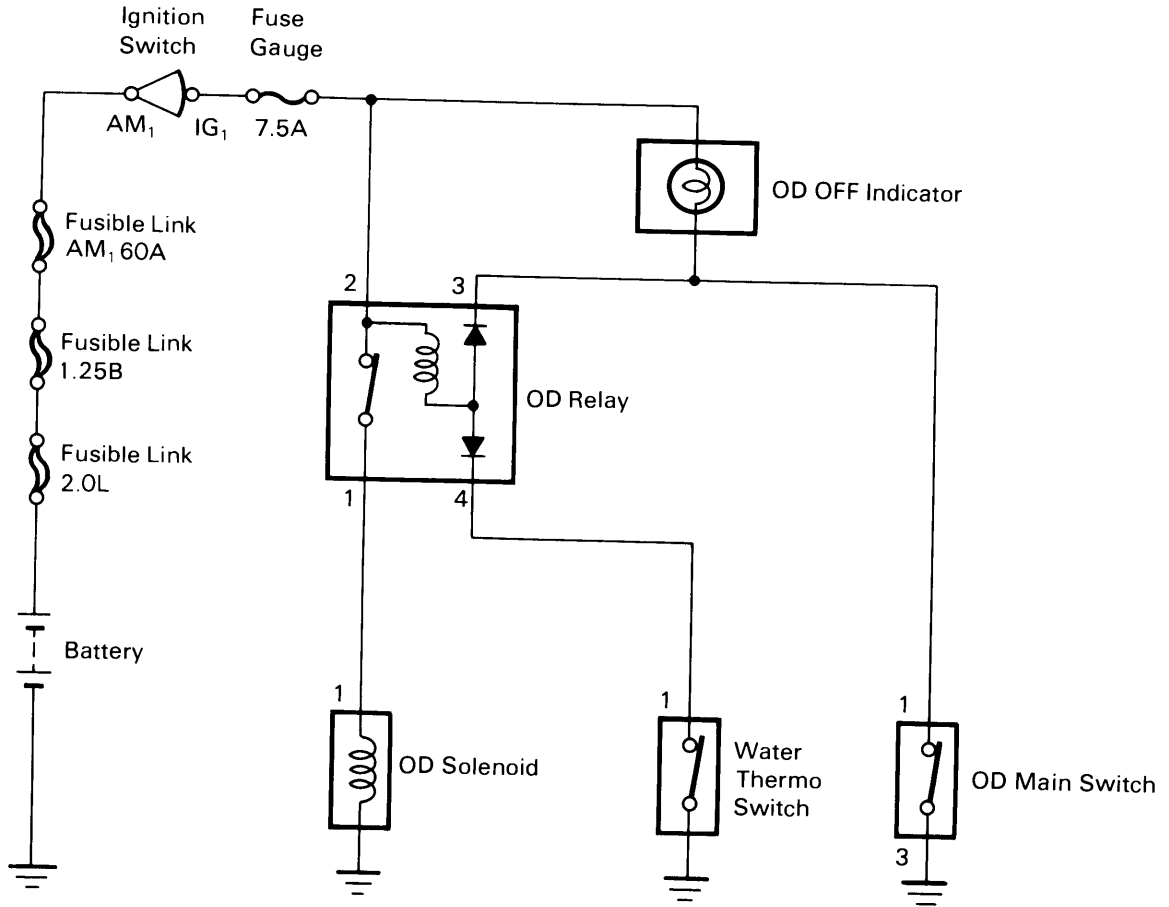

Overdrive Main Switch

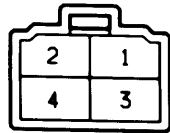

Overdrive Relay



Overdrive Solenoid



Water Thermo Switch

cardiagn.com

CIRCUIT (4WD)

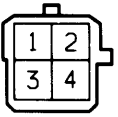
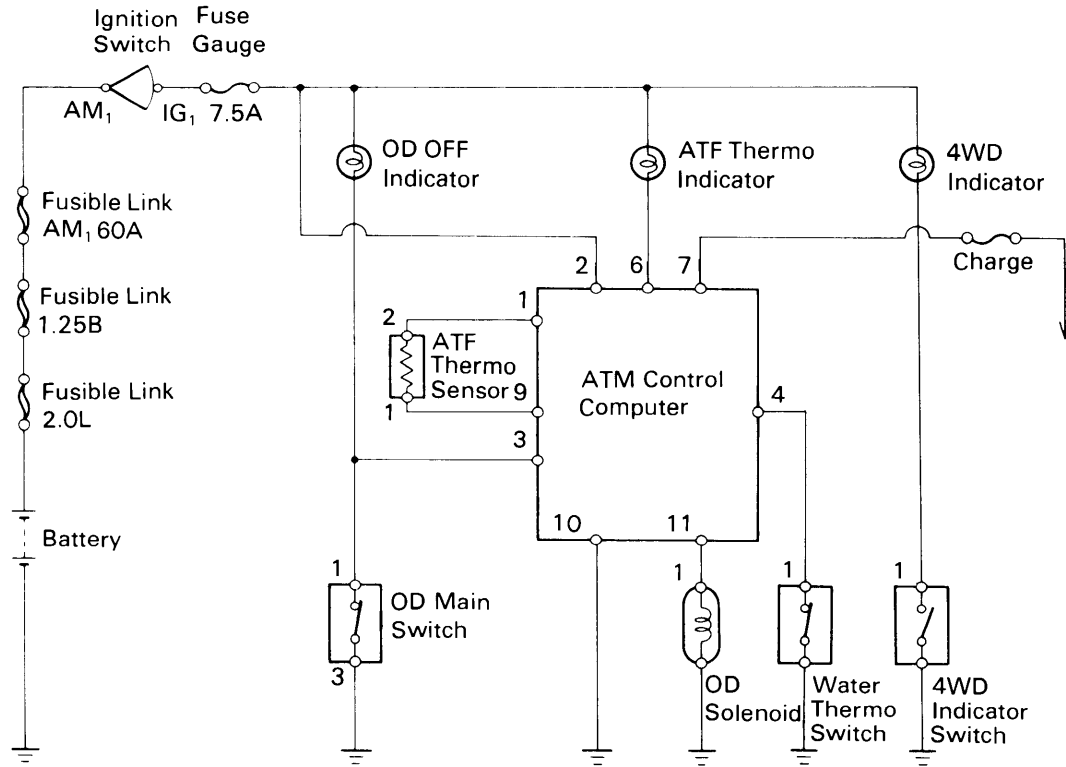

OD Main Switch



OD Solenoid



Water Thermo Switch

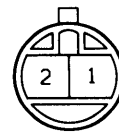

ATF Thermo Sensor



4WD Indicator Switch

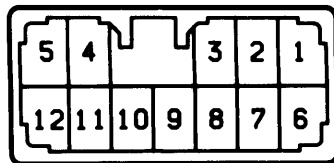

ATM Control Computer

cardiagn.com

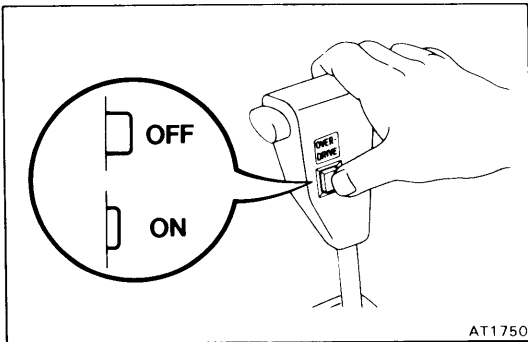

INSPECTION ELECTRIC CONTROL COMPONENTS

1. INSPECT OVERDRIVE RELAY (2WD) OR ATM CONTROL COMPUTER (4WD) AND SOLENOID

- (a) Turn on the ignition switch.
- (b) Disconnect the connector from the thermo switch.
- (c) Repeatedly turn OD main switch ON and OFF.
- (d) At this time, check that an operation sound from the solenoid and overdrive relay (2WD) or ATM control computer (4WD) can be heard.

If there is no sound from either the solenoid, overdrive relay (2WD) or ATM control computer (4WD), check them.

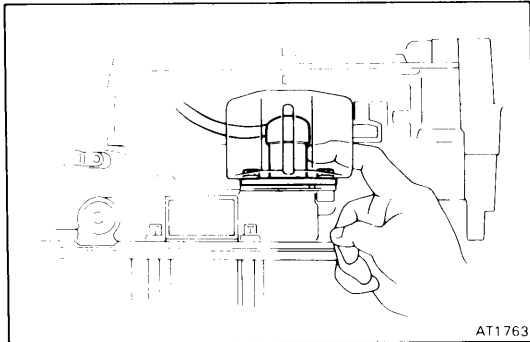

2. INSPECT OVERDRIVE RELAY (2WD)

- (a) Remove the console box.

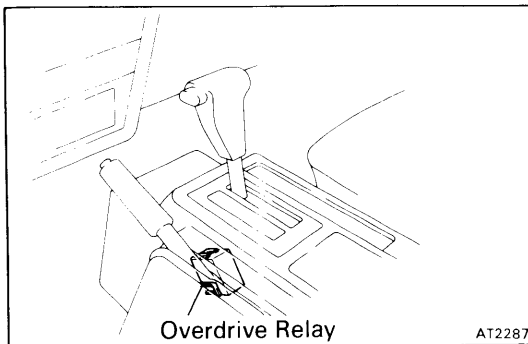

- (b) Using an ohmmeter, check that there is continuity between terminals 1 and 2.

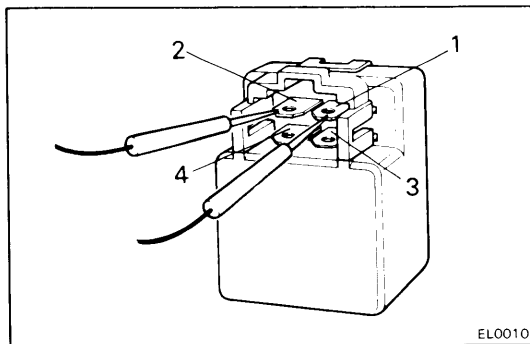

- (c) Apply 12 V battery voltage across terminals 2 and 4. Using an ohmmeter, check that there is no continuity between terminals 1 and 2.
- (d) Install the overdrive relay.
- (e) Install the console box.

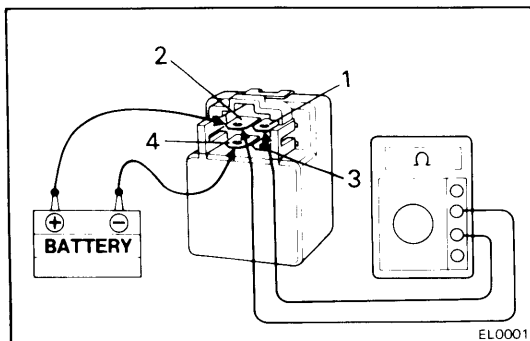

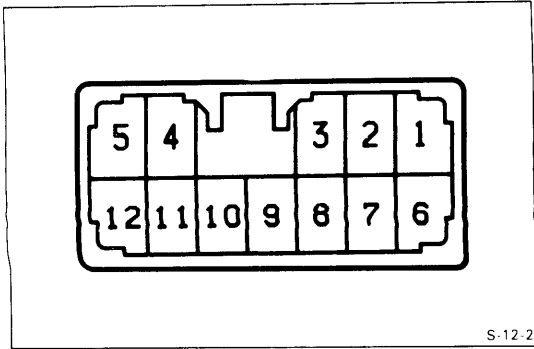

3. INSPECT ATM CONTROL COMPUTER (4WD)

- (a) Remove the console box.
- (b) Measure the voltage at each terminal.

No.	Terminal	Measuring condition	Voltage (V)
1	2 — Ground	Ignition switch ON	12 V
2	7 — Ground	Engine not running	0 V
		Engine running	12 V
3	6 — Ground	Engine not running	0 V
		Engine running	12 V
4	1 — Ground	Ignition switch OFF	0 V
		Ignition switch ON	5 V
5	3 — Ground	OD switch OFF	0 V
		OD switch ON	5 V
6	11 — Ground	OD switch OFF	0 V
		OD switch ON	12 V
7	4 — Ground	Coolant temperature below 43°C (109°F)	0 V
		Coolant temperature above 55°C (131°F)	12 V

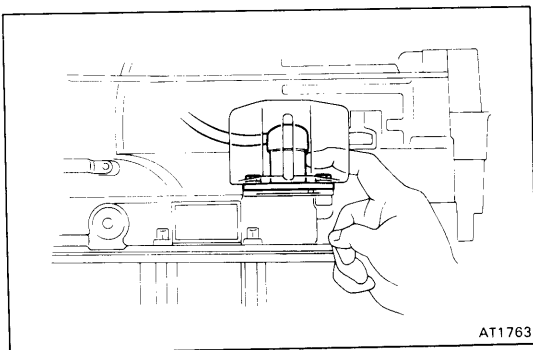

4. INSPECT OVERDRIVE SOLENOID

- (a) Disconnect the solenoid connector and apply a 12 V battery voltage to the solenoid.
Check that the solenoid operation sound is heard.

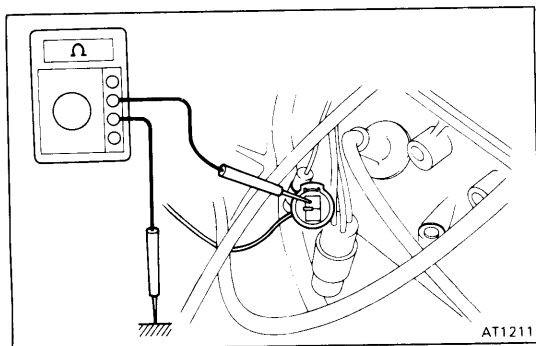

- (b) Using an ohmmeter, measure the solenoid coil resistance.

Resistance: 13 Ω

- (c) Connect the solenoid connector.

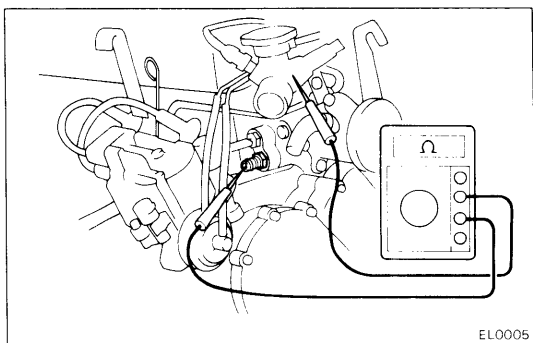

EL0005

5. INSPECT WATER THERMO SWITCH

- (a) Disconnect the thermo switch connector.
- (b) Using an ohmmeter, measure the resistance between the terminal and ground.
- (c) Connect the thermo switch connector.

Coolant temperature	Resistance (Point)
Below 43°C (109°F)	0 Ω (Closed)
Above 55°C (131°F)	∞ Ω (Open)

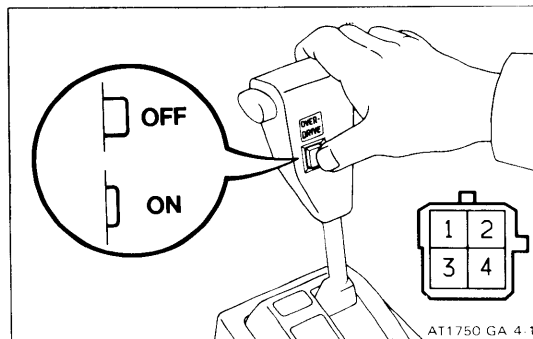

AT1750 GA 4-1

6. INSPECT OVERDRIVE MAIN SWITCH

- (a) Remove the console box.
- (b) Using an ohmmeter, check the continuity of the terminals for each switch position.

Terminal	1	2	3	4
Switch position				
ON		○	○	○
OFF	○	○	○	○

○—○: Continuity

- (c) Install the console box.

7. INSPECT OD OFF INDICATOR

- (a) Turn on the ignition switch.
- (b) Check that the OD OFF indicator does not light, when the OD main switch is turned ON.
- (c) Check that the OD OFF indicator lights, when the OD main switch is turned OFF.

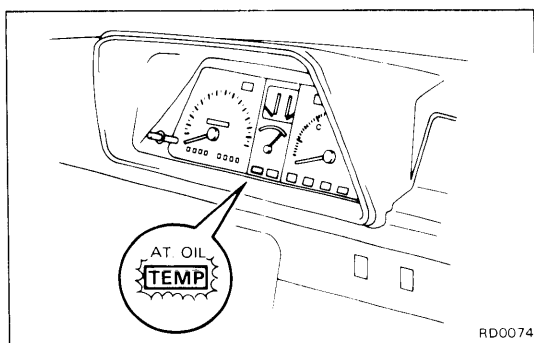

RD0074

8. INSPECT ATF THERMO INDICATOR LIGHT (4WD)

- (a) With the ignition switch ON, check that the indicator light inside the combination meter lights.
- (b) Check that when the engine is started, the indicator light goes out.

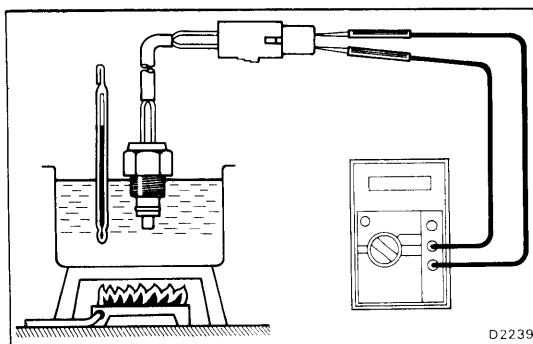

D2239

9. INSPECT ATF THERMO SENSOR (4WD)

- (a) Place the sensor in a container filled with ATF (DEXRON® II) up to the point shown in the illustration.
- (b) As the fluid is warmed, measure the resistance between the terminals.

Resistance: 541.7 — 689.5 Ω (120°C or 248°F)

NOTE: As the resistance is measured, check that the resistance value gradually drops as the temperature falls from 120°C to 25°C (248°F to 77°F).

ON-VEHICLE REPAIR

REMOVAL OF VALVE BODY

1. MAKE PLATE TO RETAIN ACCUMULATOR PISTONS

A retainer is helpful for holding accumulator pistons in the case during removal and installation of the valve body. The plate may be made of aluminum or plastic.

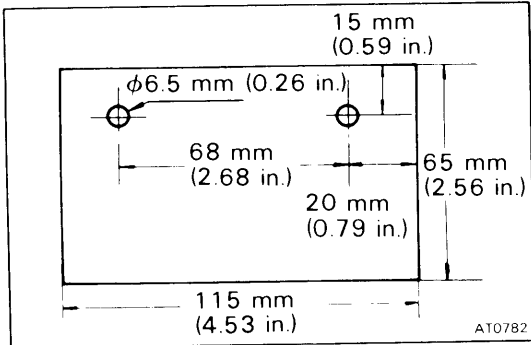

2. CLEAN TRANSMISSION EXTERIOR

To help prevent contamination, clean the exterior of the transmission.

3. DRAIN TRANSMISSION FLUID

Remove the drain plug and drain the fluid into a suitable container.

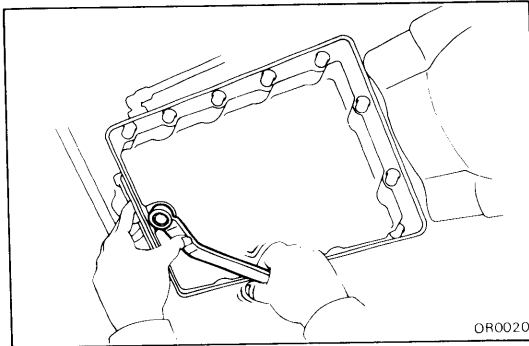

4. REMOVE OIL PAN, FILLER TUBE AND GASKET

CAUTION: Some fluid will remain in the oil pan. Be careful not to damage the filler tube and O-ring.

Remove all pan bolts, and carefully remove the pan assembly. Discard the gasket.

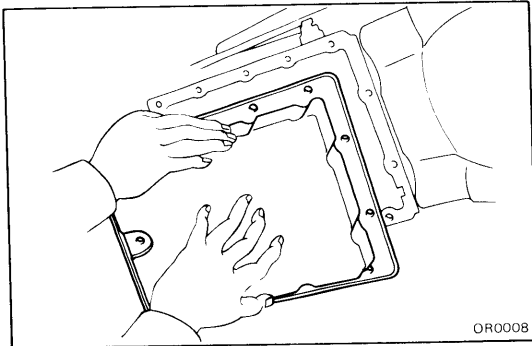

5. REMOVE OIL TUBES

Pry up both tube ends with a large screwdriver and remove the tubes.

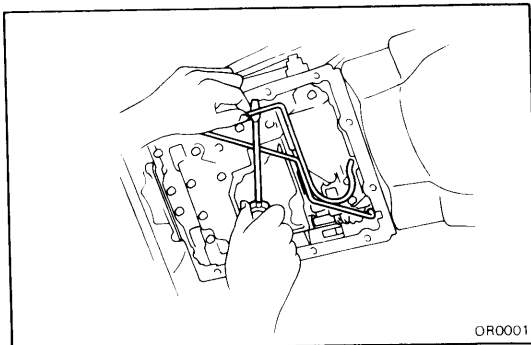

6. REMOVE OIL STRAINER

Remove the six bolts, and the oil strainer.

CAUTION: Be careful as some oil will come out with the filter.

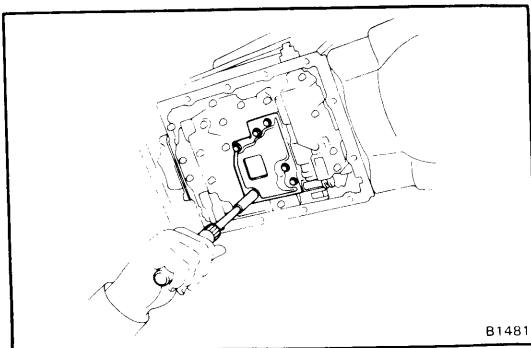

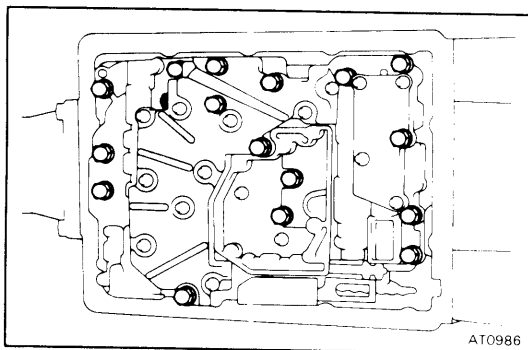

7. REMOVE VALVE BODY

(a) Remove the seventeen bolts.

NOTE: Bolt lengths will be shown for installation, so there is no need to mark them now.

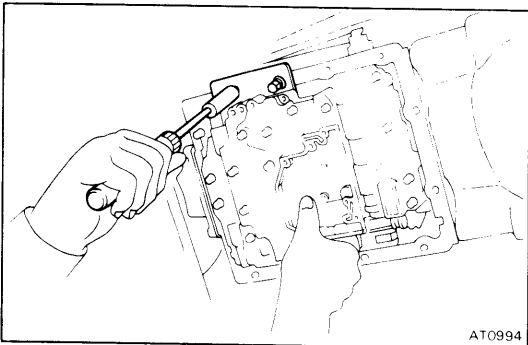

(b) Lower the valve body slightly, and install the accumulator piston retaining plate. Hold it in place with two pan bolts. Hand tighten the bolts with a socket driver.

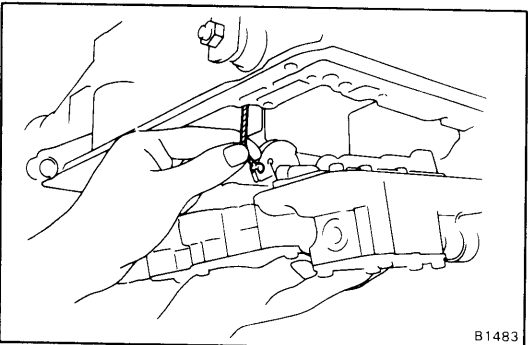

(c) Disconnect the throttle cable from the cam and remove the valve body.

DISASSEMBLY, INSPECTION AND ASSEMBLY OF VALVE BODY

(See page AT-76)

INSTALLATION OF VALVE BODY

1. CONNECT THROTTLE CABLE TO CAM

Push the cable fitting into the cam.

2. ALIGN MANUAL VALVE LEVER WITH MANUAL VALVE AND LOOSELY INSTALL SEVERAL BOLTS IN VALVE BODY

Leave the bolts loose so that the accumulator retaining plate can be removed.

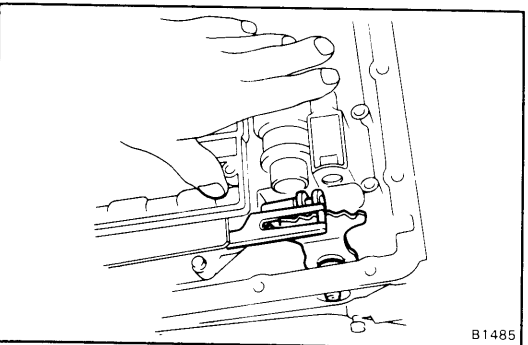

3. REMOVE ACCUMULATOR RETAINING PLATE

Remove the two pan bolts, and slide out the plate.

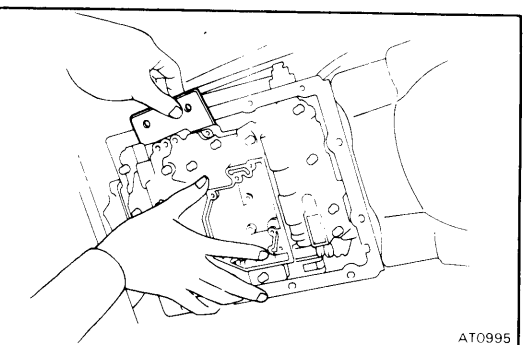

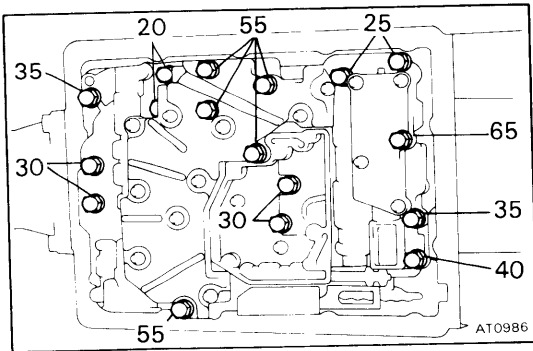

4. INSTALL VALVE BODY BOLTS

Install the bolts as shown. Tighten the bolts evenly.

Torque: 100 kg-cm (7 ft-lb, 10 N·m)

5. INSTALL OIL STRAINER

Be sure the strainer is clean. Torque the bolts.

Torque: 55 kg-cm (48 in.-lb, 5.4 N·m)

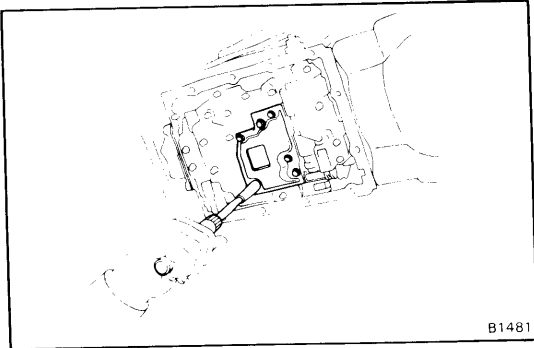

6. INSTALL OIL TUBES

Press the tubes by hand into the positions indicated in the figure.

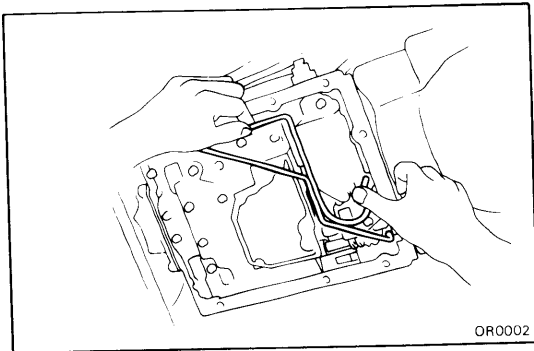

7. INSTALL PAN WITH NEW GASKET

Be sure the pan is clean and the magnets are in place.

CAUTION: Do not use gasket sealer.

Tighten the bolts evenly.

Torque: 45 kg-cm (39 in.-lb, 4.4 N·m)

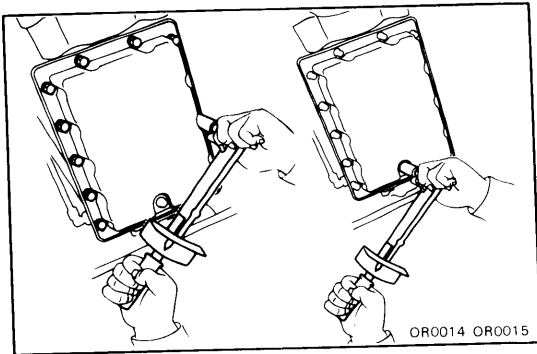

8. INSTALL DRAIN PLUG

Torque the drain plug.

Torque: 205 kg-cm (15 ft-lb, 20 N·m)

9. FILL TRANSMISSION WITH ATF

Add only about four liters of ATF.

Fluid type: ATF DEXRON® II

CAUTION: Do not overfill.

10. CHECK FLUID LEVEL
(See page MA-15)

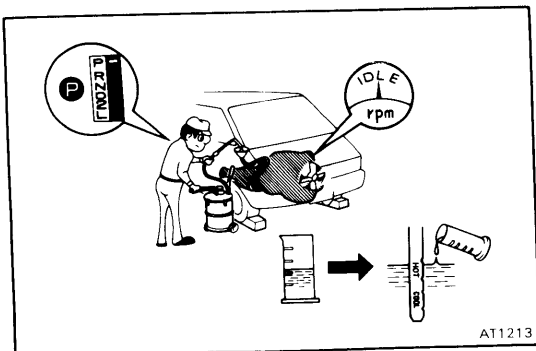

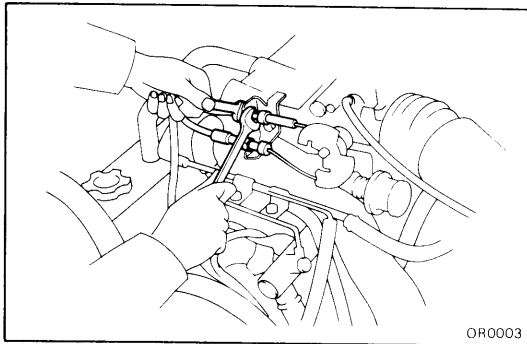

REMOVAL OF THROTTLE CABLE

1. **DISCONNECT THROTTLE CABLE**
 - (a) Disconnect the cable housing from the bracket.
 - (b) Disconnect the cable from the throttle linkage.

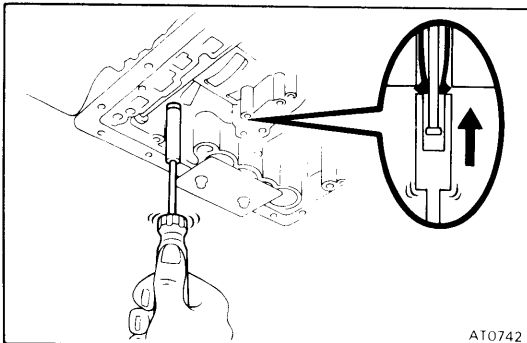

2. **REMOVE VALVE BODY** (See page AT-19)
3. **PUSH THROTTLE CABLE OUT OF TRANSMISSION CASE**
Using a 10-mm socket, push the throttle cable out.

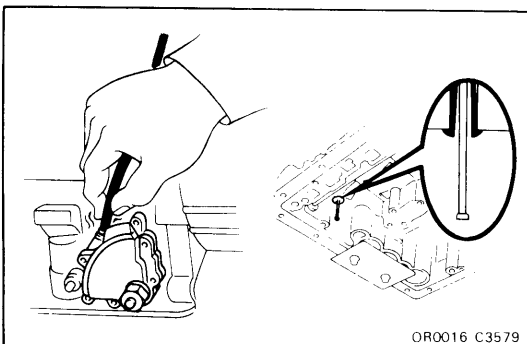

INSTALLATION OF THROTTLE CABLE

1. **INSTALL CABLE IN TRANSMISSION CASE**
Be sure to push it in all the way.
2. **INSTALL VALVE BODY** (See page AT-20)

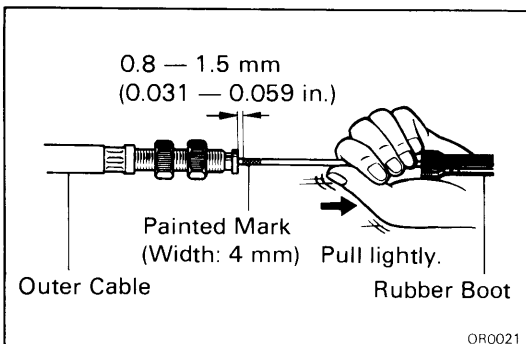

3. **IF THROTTLE CABLE IS NEW, PAINT MARK ON INNER CABLE**

NOTE: New cables do not have a cable stopper installed. Therefore, to make adjustment possible, paint a mark as described below.

- (a) Pull the inner cable lightly until a slight resistance is felt, and hold it.
- (b) Paint a mark as shown, about 4 mm (0.16 in.) in width.

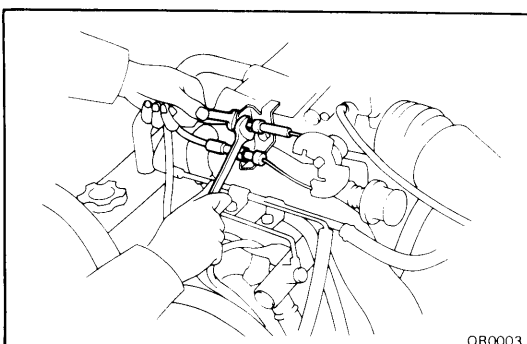

4. **CONNECT THROTTLE CABLE**
 - (a) Connect the cable to the throttle linkage.
 - (b) Connect the cable housing to the bracket.
5. **ADJUST THROTTLE CABLE** (See page AT-4)
6. **TEST DRIVE VEHICLE**

REMOVAL OF PARKING LOCK PAWL

1. REMOVE VALVE BODY (See page AT-19)
2. REMOVE PARKING LOCK PAWL BRACKET
Remove the two bolts and the bracket.

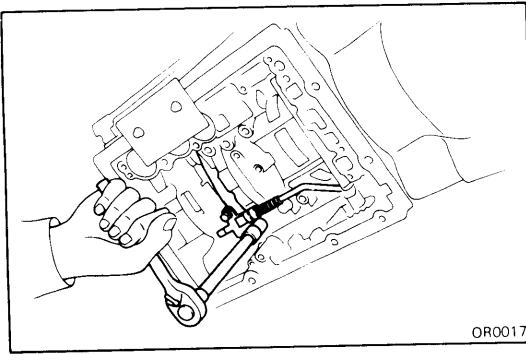

3. REMOVE SPRING FROM PARKING LOCK PAWL PIVOT PIN
4. REMOVE PIVOT PIN AND PARKING LOCK PAWL

INSTALLATION OF PARKING LOCK PAWL

1. INSTALL PARKING LOCK PAWL AND PIVOT PIN
2. INSTALL PIVOT SPRING

3. INSTALL PARKING LOCK PAWL BRACKET
 - (a) Push the lock rod fully forward.
 - (b) Install the two bolts finger tight.
 - (c) Check that the pawl operates smoothly.
 - (d) Torque the bolts.

Torque: 75 kg-cm (65 in.-lb, 7.4 N·m)
4. INSTALL VALVE BODY (See page AT-20)

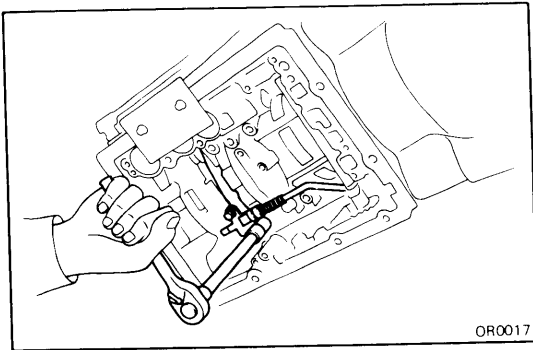
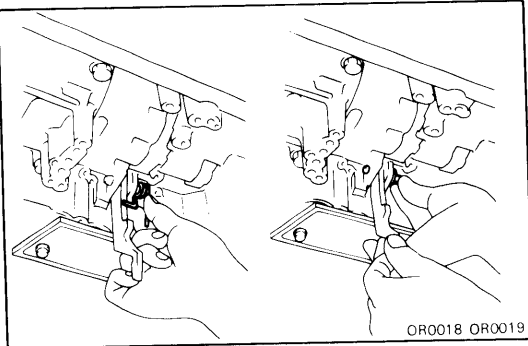

REPLACEMENT OF REAR OIL SEAL (2WD)

1. RAISE VEHICLE, AND POSITION PAN TO CATCH ANY FLUID THAT MAY DRIP
2. REMOVE PROPELLER SHAFT

3. REMOVE REAR DUST SEAL AND OIL SEAL

CAUTION: Clean the extension housing before removing the seal.

Using SST, remove the two seals.

SST 09308-10010

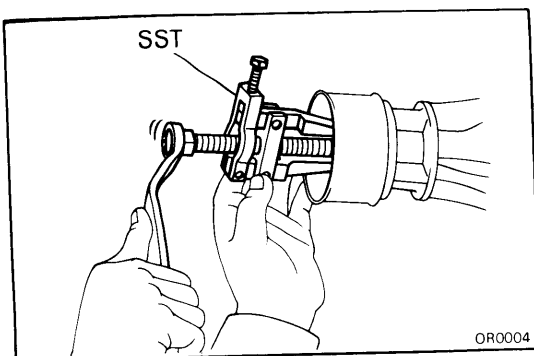

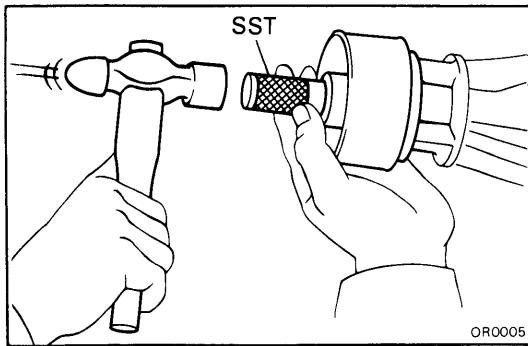

4. INSTALL NEW OIL SEAL AND DUST SEAL

Using SST, drive in the oil seal as far as it will go. Drive in the dust seal flush with the housing.

SST 09325-20010

5. INSTALL PROPELLER SHAFT

6. LOWER VEHICLE AND CHECK FLUID LEVEL (See page MA-15)

Add fluid as necessary.

Fluid type: ATF DEXRON® II

CAUTION: Do not overfill.

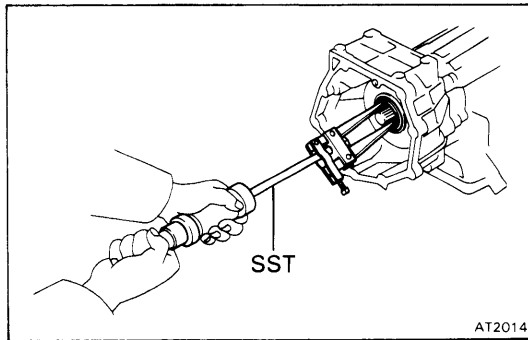

REPLACEMENT OF REAR OIL SEAL (4WD)

1. RAISE VEHICLE, AND POSITION PAN TO CATCH ANY FLUID THAT MAY DRIP

2. REMOVE TRANSFER (See page TF-5)

3. REMOVE REAR OIL SEAL

CAUTION: Clean the transfer adaptor before removing the oil seal.

Using SST, remove the oil seal.

SST 09308-00010

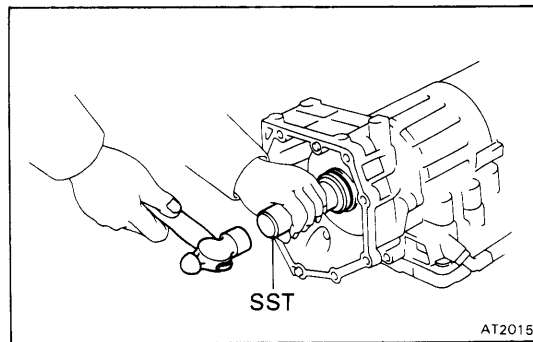

4. INSTALL NEW OIL SEAL

Using SST, drive in a new oil seal.

SST 09350-20015 (09388-20010)

5. INSTALL TRANSFER (See page TF-52)

6. LOWER VEHICLE AND CHECK FLUID LEVEL (See page MA-15)

Add fluid as necessary.

Fluid type: ATF DEXRON® II

CAUTION: Do not overfill.

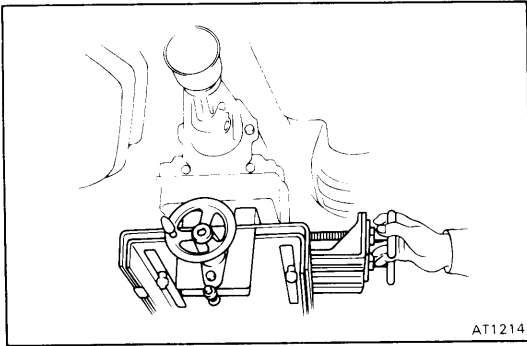

AT1214

REMOVAL OF GOVERNOR ASSEMBLY (2WD)

1. RAISE VEHICLE AND POSITION PAN TO CATCH ANY FLUID THAT DRIPS
2. REMOVE PROPELLER SHAFT
3. SUPPORT TRANSMISSION WITH JACK

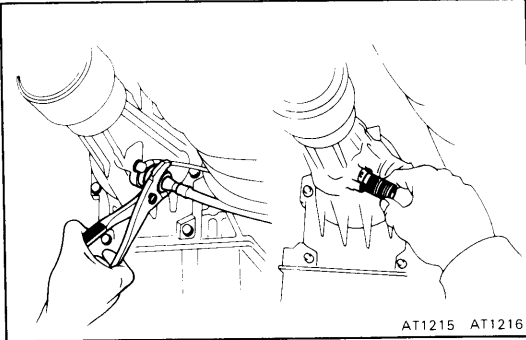

AT1215 AT1216

4. DISCONNECT SPEEDOMETER CABLE
5. REMOVE SPEEDOMETER DRIVEN GEAR

Remove the bolt and locking tab. Pry out the speedometer gear with a screwdriver.

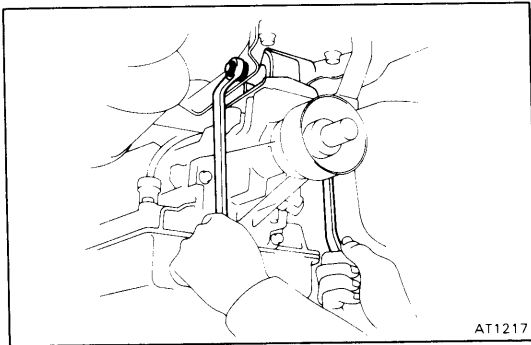

AT1217

6. REMOVE TRANSMISSION MOUNTING THROUGH BOLT

- (a) Remove the two fuel tank mount bolts and support the fuel tank.
- (b) Remove the transmission mounting through bolt.

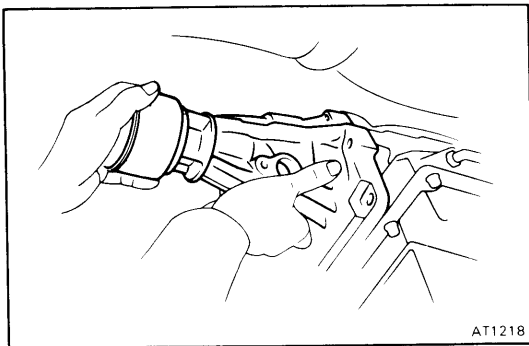

AT1218

7. REMOVE EXTENSION HOUSING AND GASKET

Remove the six bolts. If necessary, tap the extension housing with a soft-faced hammer or block of wood to loosen it.

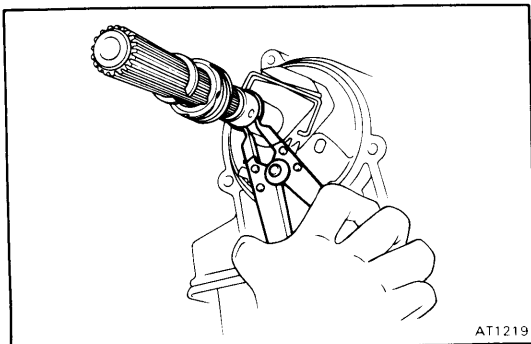

AT1219

8. REMOVE SPEEDOMETER DRIVE GEAR

- (a) Using snap ring pliers, remove the snap ring.
- (b) Slide off the speedometer gear.
- (c) Remove the lock ball and the other snap ring.

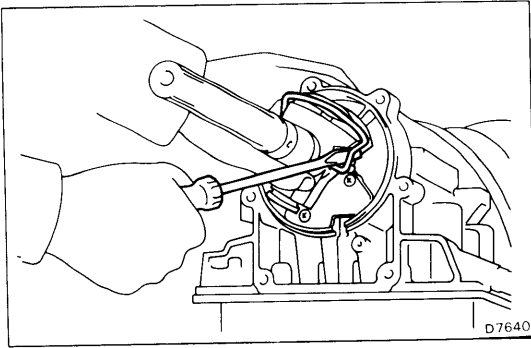

9. REMOVE GOVERNOR FROM OUTPUT SHAFT

- (a) Using a larger screwdriver, lift the retaining clip.
- (b) Unstake the lock plate, remove the bolt and lock plate.
- (c) Remove the governor.

INSPECTION AND REPAIR OF GOVERNOR ASSEMBLY (2WD)

(See page AT-99)

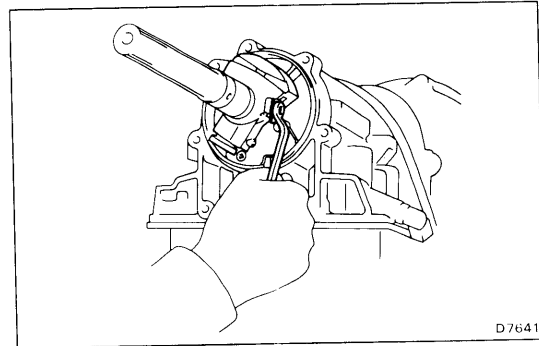

INSTALLATION OF GOVERNOR ASSEMBLY (2WD)

1. INSTALL GOVERNOR ON OUTPUT SHAFT

- (a) Using a large screwdriver, lift the retaining clip, and slide the governor on the shaft with the retaining ring facing the end of the shaft.
- (b) Release the retaining clip into the hole in the output shaft. Check that the governor assembly is secure.
- (c) Install the bolt and lock plate, stake the lock plate.

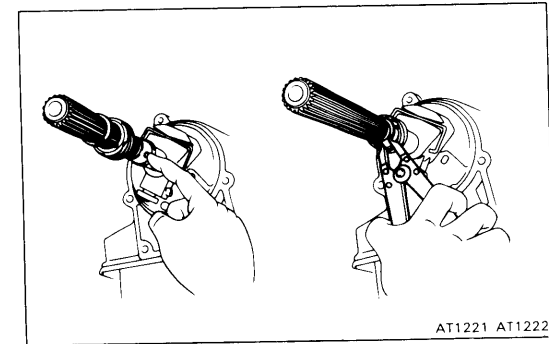

2. INSTALL SPEEDOMETER DRIVE GEAR

- (a) Install the snap ring and lock ball.
- (b) Slide the speedometer gear onto the shaft.
- (c) Using snap ring pliers, install the outer snap ring.

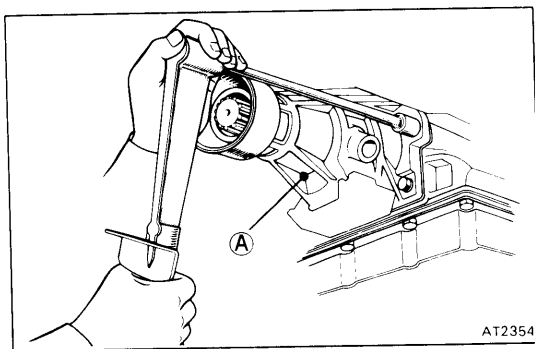

3. INSTALL NEW GASKET AND EXTENSION HOUSING ON TRANSMISSION

- (a) Clean the threads of the (A) bolt and bolt hole with white gasoline.
- (b) Coat the threads of the (A) bolt with sealer.

Sealer: Part No. 08833-00080, THREE BOND 1344, LOCTITE 242 or equivalent

- (c) Install the extension housing over a new gasket with bolts, and then torque them.

NOTE: The two lower bolts are shorter.

Torque: 345 kg-cm (25 ft-lb, 34 N·m)

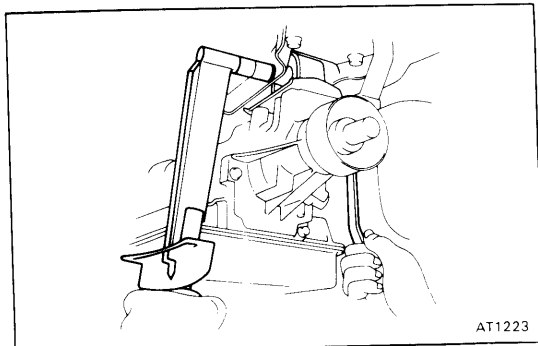

4. INSTALL TRANSMISSION MOUNTING THROUGH BOLT

- (a) Raise the transmission with the jack to allow installation of the transmission mounting through bolt.
- (b) Torque the through bolt.

Torque: 500 kg-cm (36 ft-lb, 49 N·m)

- (c) Install the two fuel tank set bolts.

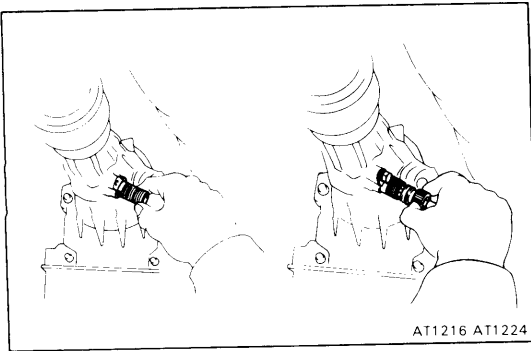

5. INSTALL SPEEDOMETER DRIVEN GEAR

- (a) Install a new O-ring on the shaft sleeve.
- (b) Install the lock plate with a bolt and washer.

6. CONNECT SPEEDOMETER CABLE

Place the felt dust protector and washer on the end of the cable. Tighten the collar with pliers.

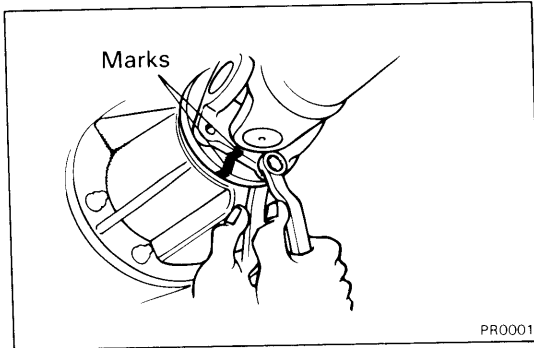

7. INSTALL PROPELLER SHAFT

Torque: 430 kg-cm (31 ft-lb, 42 N·m)

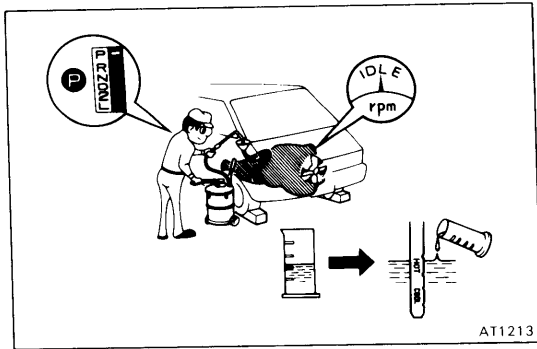

8. LOWER VEHICLE AND CHECK FLUID LEVEL
(See page MA-15)

Add fluid as necessary.

Fluid type: ATF DEXRON® II

CAUTION: Do not overfill.

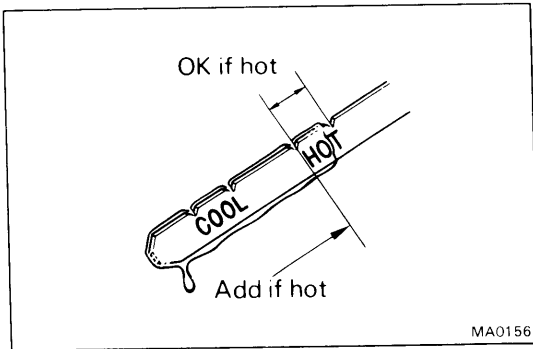

REMOVAL OF GOVERNOR ASSEMBLY (4WD)

1. RAISE VEHICLE AND POSITION PAN TO CATCH ANY FLUID THAT DRIPS
2. REMOVE TRANSFER (See page TF-5)

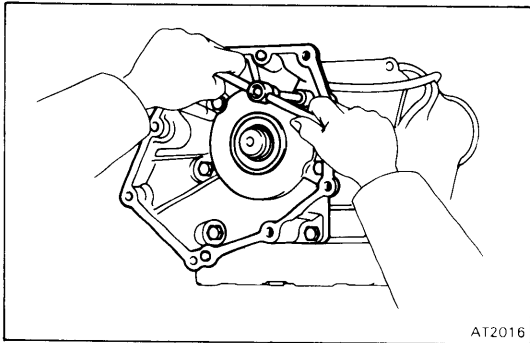

AT2016

3. REMOVE TRANSFER ADAPTOR

Remove the six bolts. If necessary, tap the transfer adaptor with a soft-faced hammer or brock of wood to loosen it.

NOTE: When removing the transfer adaptor, be careful not to damage the oil seal.

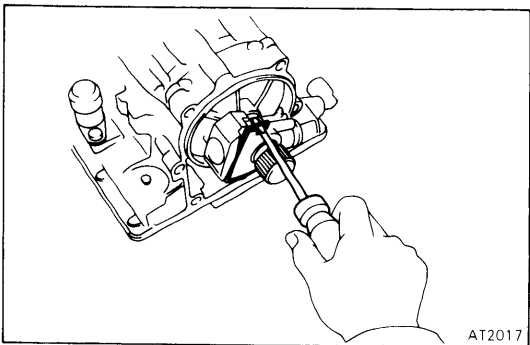

AT2017

4. REMOVE GOVERNOR BODY FROM OUTPUT SHAFT

- (a) Using a larger screwdriver, remove the retaining clip.

- (b) Unstake the lock plate, remove the bolt and lock plate.
- (c) Remove the governor body.

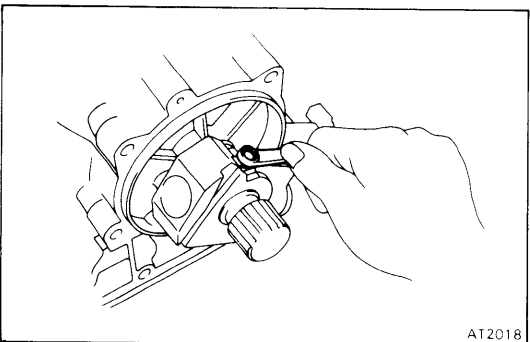

AT2018

INSPECTION AND REPAIR OF GOVERNOR ASSEMBLY (4WD)

(See page AT-99)

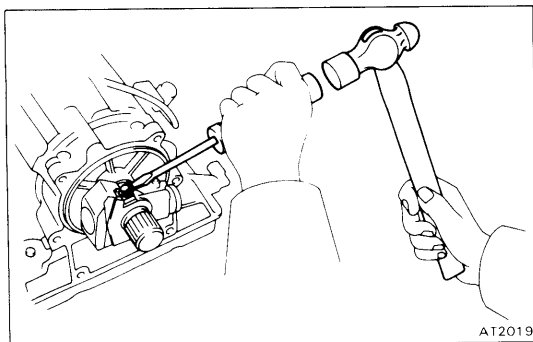

INSTALLATION OF GOVERNOR ASSEMBLY (4WD)

1. INSTALL GOVERNOR BODY ON OUTPUT SHAFT

- (a) Align the governor body and bolt hole on the output shaft.
- (b) Install the bolt and lock plate, stake the lock plate.
- (c) Using a large screwdriver, install the retaining clip into the hole in the output shaft.
- (d) Check that the governor assembly is secure.

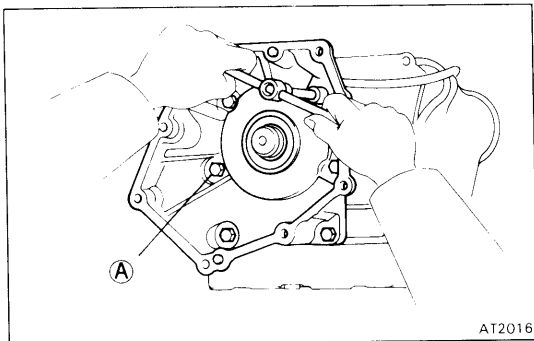
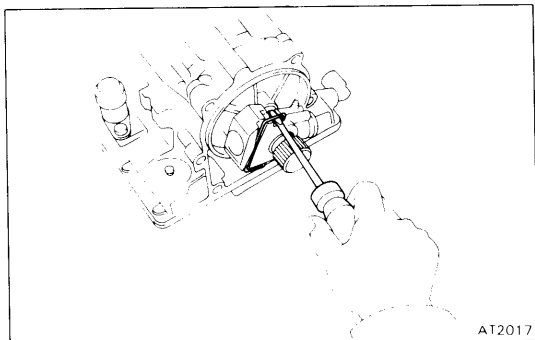

2. INSTALL NEW GASKET AND TRANSFER ADAPTOR ON TRANSMISSION

- (a) Clean the threads of the (A) bolt and bolt hole with white gasoline.
- (b) Coat the threads of the (A) bolt with sealer.
Sealer: Part No. 08833-00080, THREE BOND 1344, LOCTITE 242 or equivalent
- (c) Install the transfer adaptor over a new gasket with bolts and then torque them.

Torque: 345 kg-cm (25 ft-lb, 34 N·m)

NOTE: When installing the transfer adaptor, be careful not to damage the oil seal.

3. INSTALL TRANSFER (See page TF-52)

4. LOWER VEHICLE AND CHECK FLUID LEVEL (See page MA-15)

Add fluid as necessary.

Fluid type: ATF DEXRON® II

CAUTION: Do not overfill.

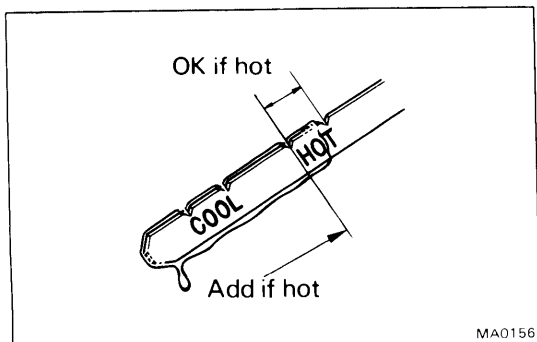
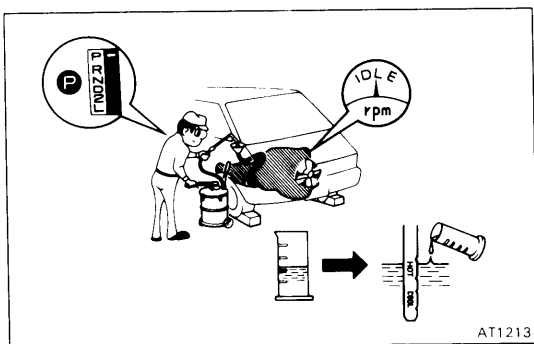

REMOVAL OF TRANSMISSION (2WD)

1. DISCONNECT BATTERY CABLE FROM NEGATIVE (-) TERMINAL

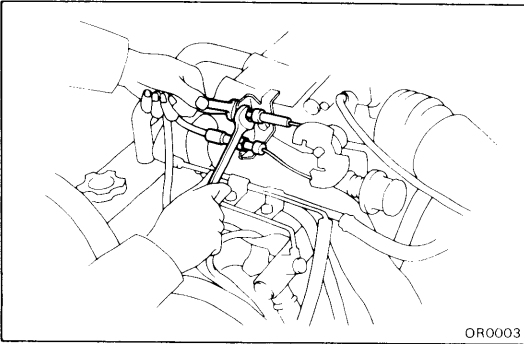

2. DISCONNECT TRANSMISSION THROTTLE CABLE

- (a) Loosen the adjusting nuts, and disconnect the cable housing from the bracket.
- (b) Disconnect the cable from the throttle linkage.

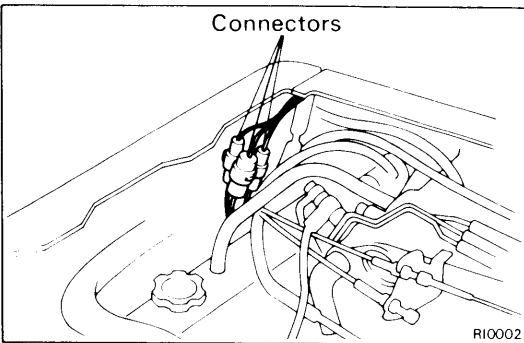

3. DISCONNECT WIRING CONNECTORS

Disconnect the neutral start switch, back-up light and overdrive solenoid connectors.

4. RAISE VEHICLE AND DRAIN TRANSMISSION

CAUTION: Be sure the vehicle is securely supported.

5. REMOVE PROPELLER SHAFT

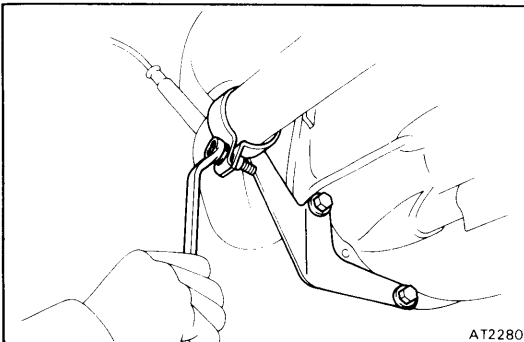

6. DISCONNECT EXHAUST PIPE CLAMP FROM TRANSMISSION HOUSING

7. REMOVE EXHAUST PIPE CLAMP

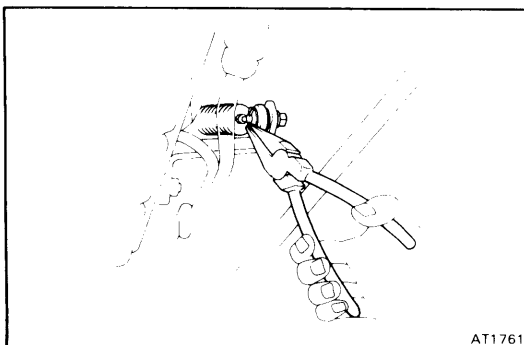

8. DISCONNECT SHIFT CABLE FROM TRANSMISSION

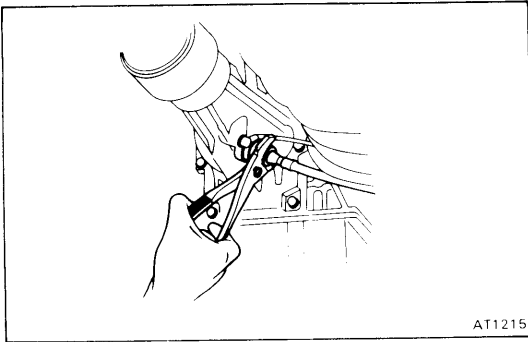

9. DISCONNECT SPEEDOMETER CABLE AND BOND CABLE

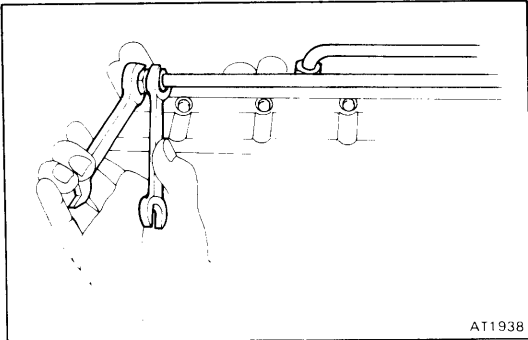

10. DISCONNECT TWO OIL COOLER LINES

- (a) Loosen the two nuts.
- (b) Remove the two clamps and disconnect the two oil cooler lines.

11. REMOVE STARTER

- (a) Remove the mounting bolts, and pull the starter toward the front of the vehicle.
- (b) Lay the starter alongside the engine.

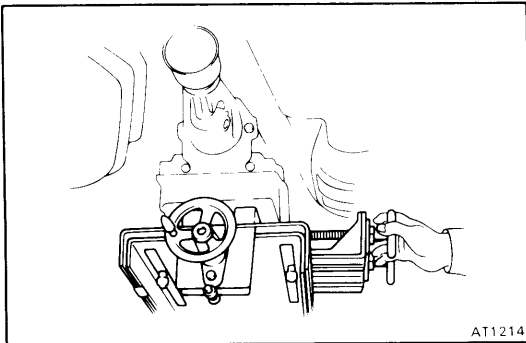

12. SUPPORT TRANSMISSION WITH JACK

If a transmission jack is not available, be sure to put a wooden block between the jack and the transmission pan to prevent damage.

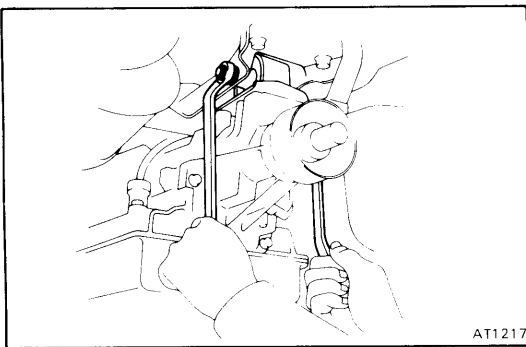

13. REMOVE TRANSMISSION MOUNTING THROUGH BOLT

- (a) Remove the two fuel tank mount bolts and support the fuel tank.
- (b) Remove the transmission mounting through bolt.

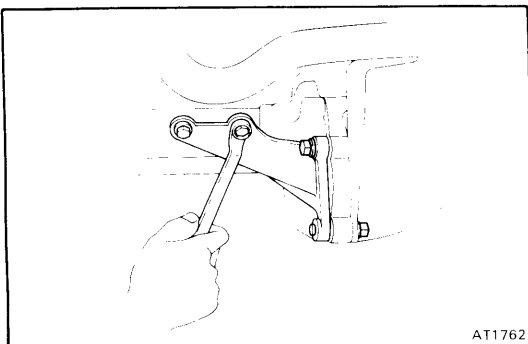

14. REMOVE BOTH STIFFNER PLATES FROM TRANSMISSION HOUSING

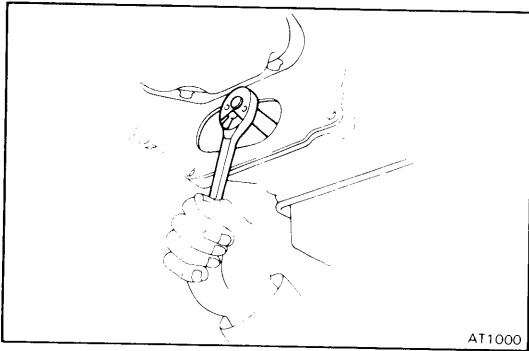

AT1000

15. REMOVE SIX TORQUE CONVERTER MOUNTING BOLTS

- (a) Pry out the service hole cover at the rear of the engine.
- (b) Turn the crankshaft to gain access to each bolt. Remove the six bolts.

16. REMOVE TRANSMISSION HOUSING MOUNTING BOLTS

17. REMOVE TRANSMISSION ASSEMBLY

Draw out the transmission down and toward the rear.

CAUTION: Do not catch the throttle cable or neutral start switch cable. Keep the oil pan positioned downward.

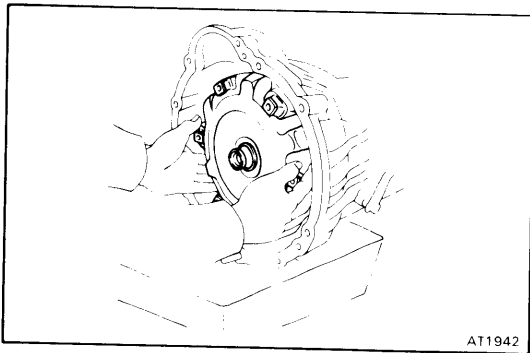

AT1942

18. PLACE PAN UNDER CONVERTER HOUSING, AND REMOVE CONVERTER

Pull the converter straight off, and allow the fluid to drain into the pan.

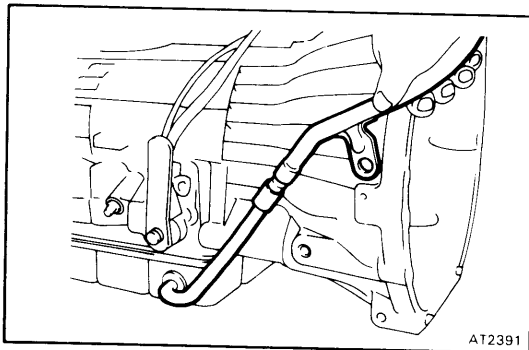

AT2391

19. REMOVE FILLER TUBE

20. REMOVE TRANSMISSION MOUNTING

REMOVAL OF TRANSMISSION (4WD)

1. **DISCONNECT BATTERY CABLE FROM NEGATIVE (-) TERMINAL**

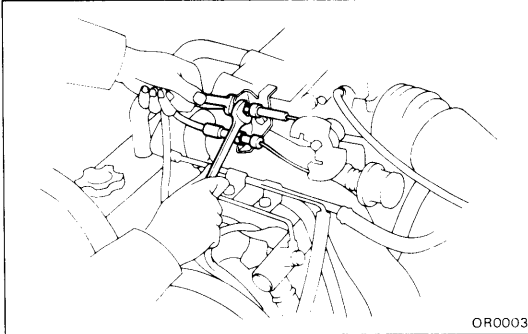

2. **DISCONNECT TRANSMISSION THROTTLE CABLE**
 - (a) Loosen the adjusting nuts, and disconnect the cable housing from the bracket.
 - (b) Disconnect the cable from the throttle linkage.

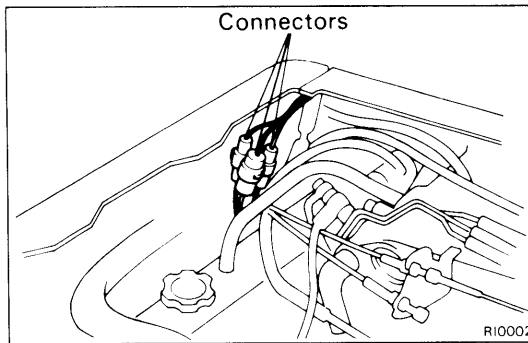

3. **DISCONNECT THE THREE WIRING CONNECTORS**
Disconnect the three connectors located near the starter.
4. **RAISE VEHICLE AND DRAIN TRANSMISSION AND TRANSFER**
CAUTION: Be sure the vehicle is securely supported.
5. **DISCONNECT ATF THERMO SENSOR CONNECTOR**

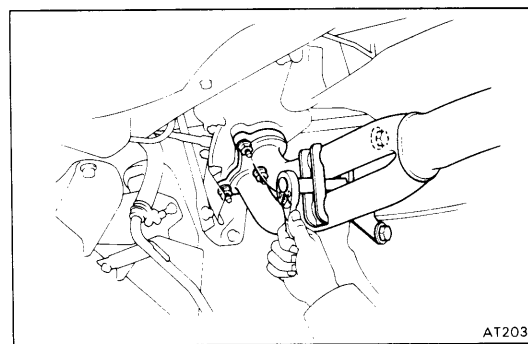

6. **REMOVE FRONT AND REAR PROPELLER SHAFTS**
(See page PR-3)

7. **DISCONNECT EXHAUST PIPE FROM MANIFOLD**
 - (a) Remove the exhaust pipe clamp from the transmission housing.
 - (b) Disconnect the exhaust pipe from the manifold.

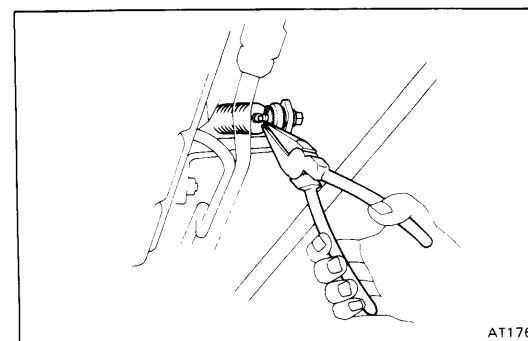

8. **DISCONNECT TRANSMISSION SHIFT CABLE FROM TRANSMISSION OUTER LEVER**

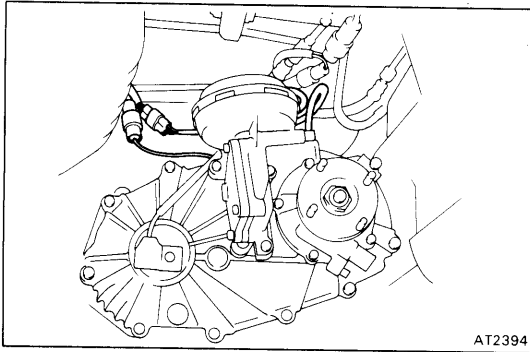

9. DISCONNECT VACUUM HOSES FROM VACUUM ACTUATOR

10. DISCONNECT SPEED SENSOR AND 4WD INDICATOR CONNECTORS

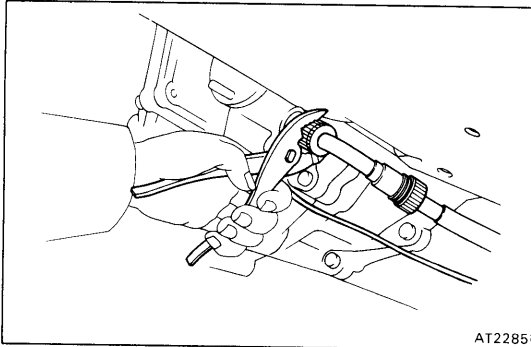

11. DISCONNECT SPEEDOMETER CABLE, GROUND STRAP AND TRANSFER INDICATOR SWITCH CONNECTOR

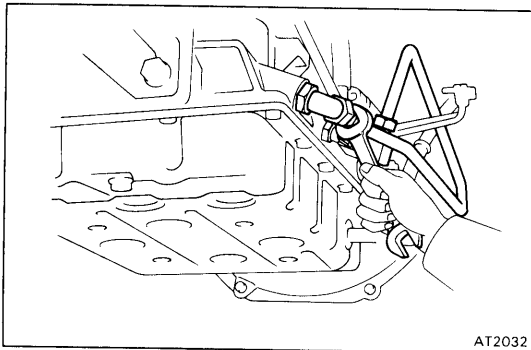

12. DISCONNECT OIL COOLER LINES

- (a) Loosen the two union nuts.
- (b) Remove the two clamps and disconnect the two oil cooler lines.

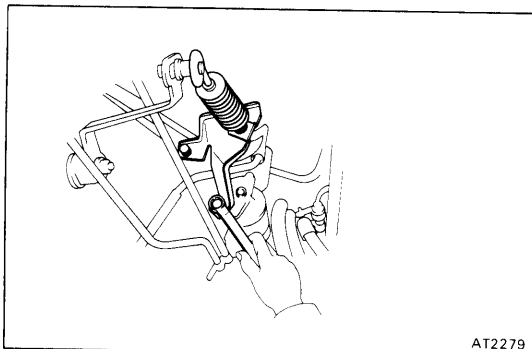

13. REMOVE CONTROL CABLE BRACKET FROM TRANSMISSION HOUSING

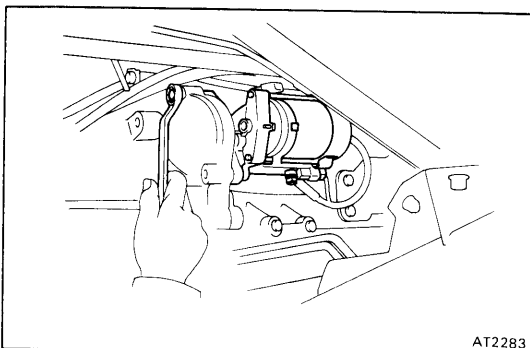

14. REMOVE STARTER

- (a) Remove the mounting bolt and pull the starter toward the front of the vehicle.
- (b) Lay the starter alongside the engine.

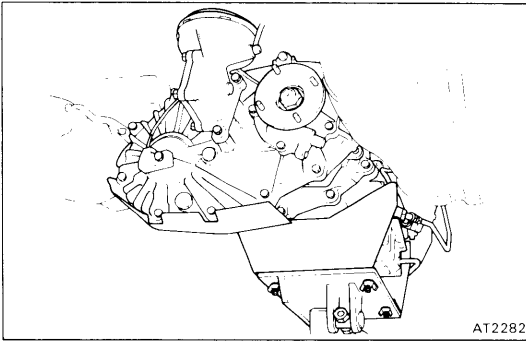
**15. SUPPORT TRANSMISSION WITH JACK**

If a transmission jack is not available, be sure to put a wooden block between the jack and the transmission pan to prevent damage.

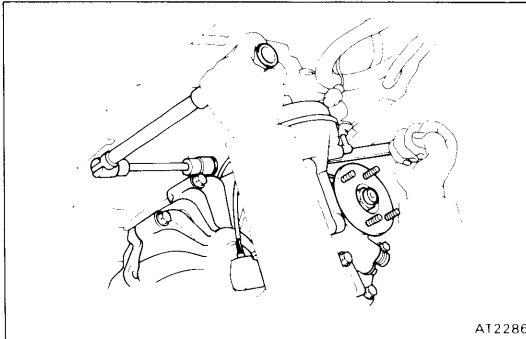
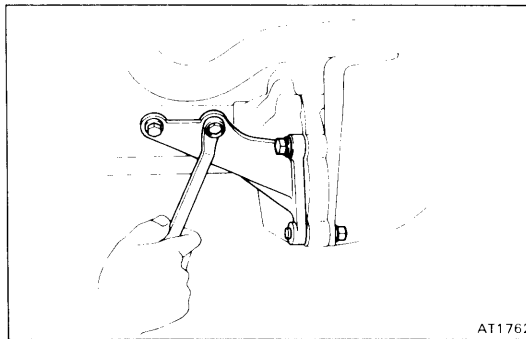
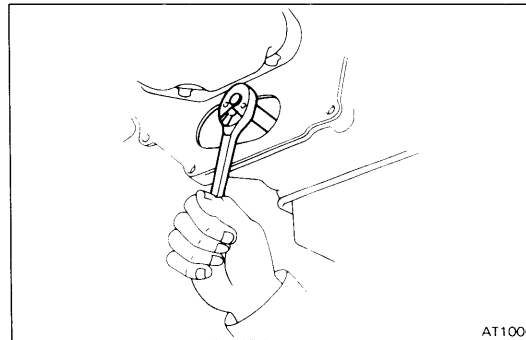
**16. REMOVE TRANSMISSION MOUNTING THROUGH BOLT****17. REMOVE BOTH STIFFENER PLATES FROM TRANSMISSION HOUSING****18. REMOVE TORQUE CONVERTER MOUNTING BOLTS**

- (a) Pry out the service hole cover at the rear of the engine.
- (b) Turn the crankshaft to gain access to each bolt. Remove the six bolts.

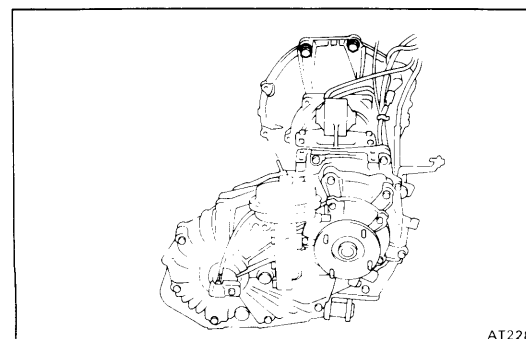
**19. REMOVE TRANSMISSION HOUSING MOUNTING BOLTS****20. REMOVE TRANSMISSION ASSEMBLY**

Draw out the transmission down and toward the rear.

CAUTION: Do not entangle the throttle cable of neutral start switch cable. Keep the oil pan positioned downward.

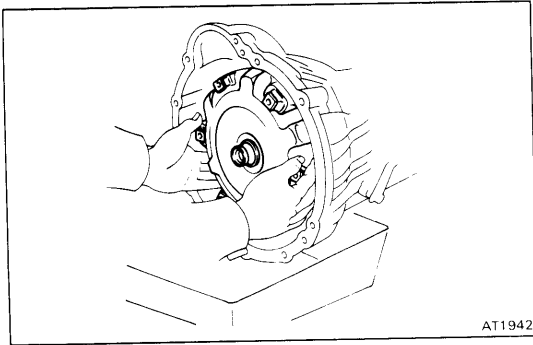

21. PLACE PAN UNDER CONVERTER HOUSING, AND REMOVE CONVERTER

Pull the converter straight off, and allow the fluid to drain into the pan.

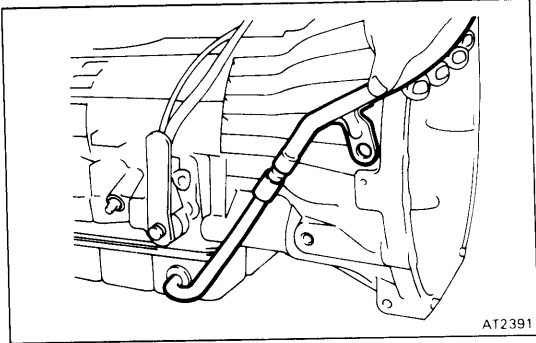

22. REMOVE FILLER TUBE

23. REMOVE TRANSMISSION MOUNTING

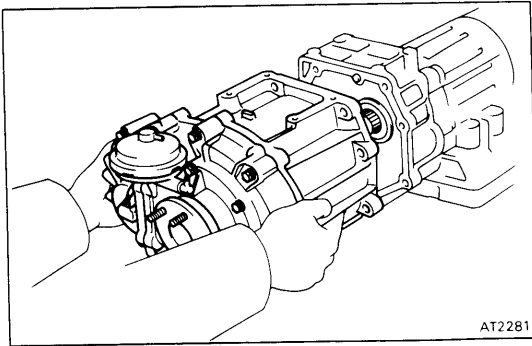

24. REMOVE TRANSFER

- (a) Remove the eight bolts.
- (b) Remove the transfer.

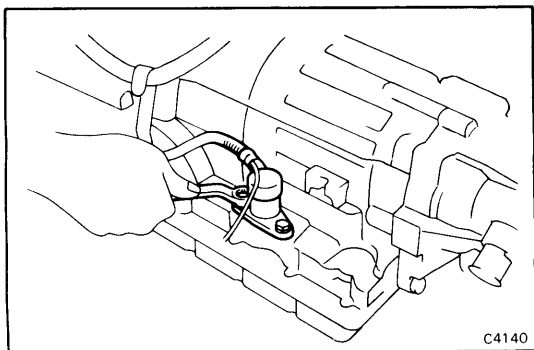

C4140

DISASSEMBLY OF TRANSMISSION SEPARATE BASIC SUBASSEMBLY

1. REMOVE CLAMP FOR WIRING AND THROTTLE CABLE
2. REMOVE SOLENOID AND O-RINGS
3. REMOVE SHIFT HANDLE
4. REMOVE NEUTRAL START SWITCH

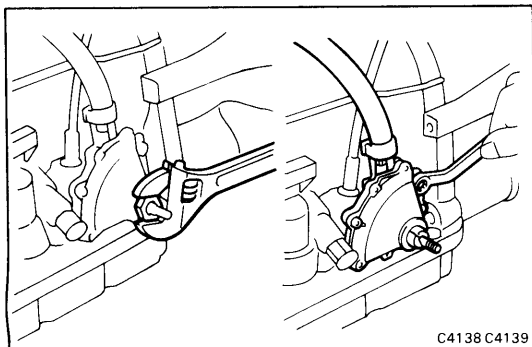

C4138 C4139

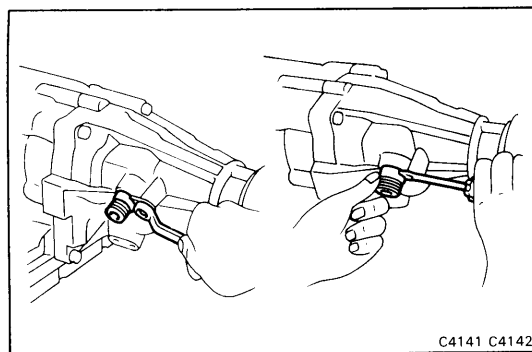

C4141 C4142

5. [2WD]
REMOVE SPEEDOMETER DRIVEN GEAR

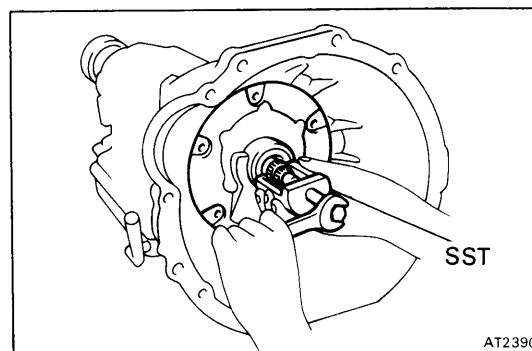

AT2390

6. REMOVE OIL PUMP

- (a) Remove the seven bolts.
- (b) Position SST on shaft in back of the spline.
SST 09610-20012

CAUTION: Do not damage the shaft bushing surface.
Turn the end bolt of SST to free the pump.

- (c) Grasp the front pump stator shaft and pull the pump from the case.

7. BE CAREFUL OF BEARING BEHIND OIL PUMP

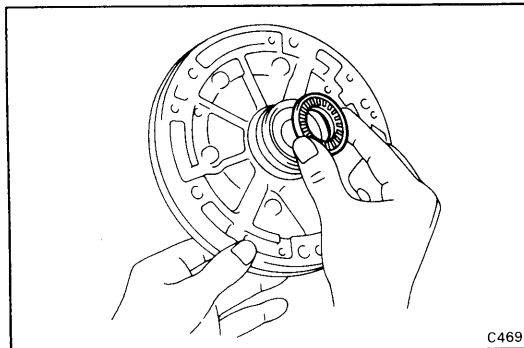

C4697

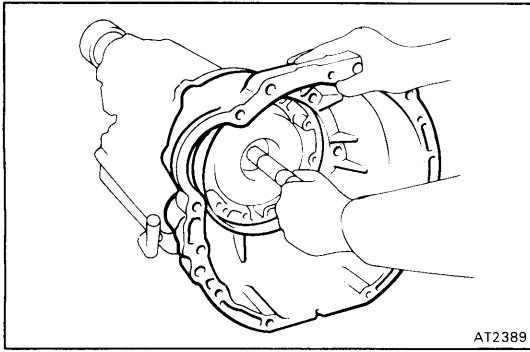
**8. REMOVE CONVERTER HOUSING**

- (a) Remove the two 12-mm bolts and four 10-mm bolts.
- (b) While holding the input shaft, remove the converter housing.

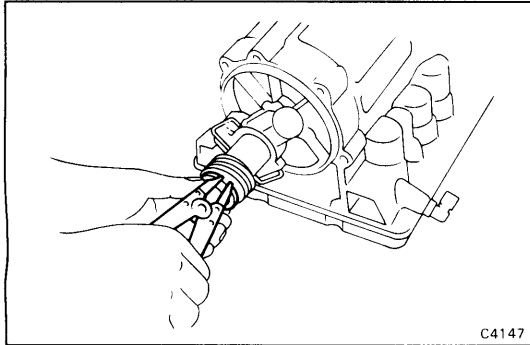
**9. [2WD]
REMOVE EXTENSION HOUSING****10. [4WD]
REMOVE TRANSFER ADAPTOR
(See page AT-28)****11. [2WD]
REMOVE SPEEDOMETER DRIVE GEAR****12. REMOVE GOVERNOR BODY FROM OUTPUT SHAFT**

- (a) Loosen the staked part of the lock plate.
- (b) Remove the governor body lock bolt.
- (c) While lifting the retaining clip with a larger screwdriver, slide off the governor body.

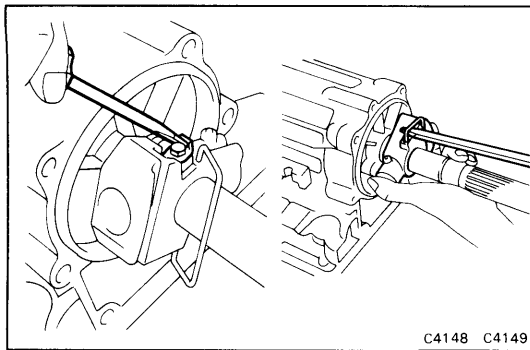
**13. IF NECESSARY, REMOVE GOVERNOR STRAINER**

- (a) Remove the three screws and plate.
- (b) Remove the strainer from the case.

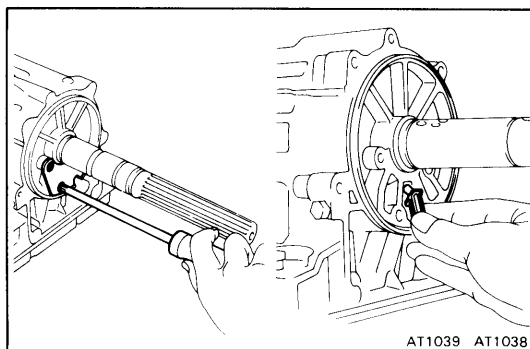
**14. REMOVE PAN AND GASKET**

- (a) Remove the fourteen bolts.
- (b) Remove the pan by lifting the transmission case.

CAUTION: Do not turn the transmission over as this will contaminate the valve body with the foreign material in the bottom of the pan.

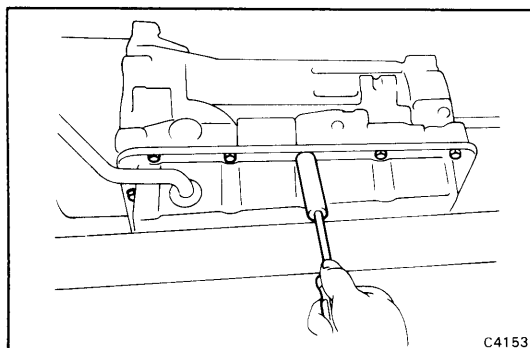

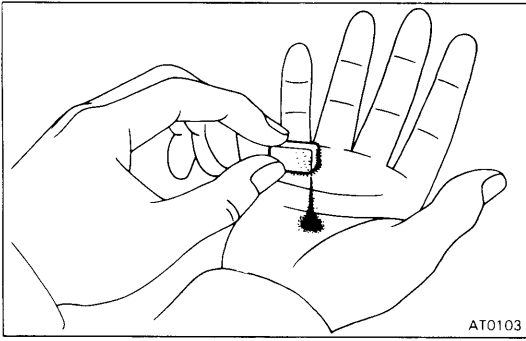
**15. EXAMINE PARTICLES IN PAN**

Remove magnets and use them to collect any steel chips. Lock carefully at the chips and particles in the pan and on the magnets to anticipate what type of wear you will find in the transmission:

Steel (magnetic) = bearing, gear and clutch plate wear

Brass (nonmagnetic) = bushing wear

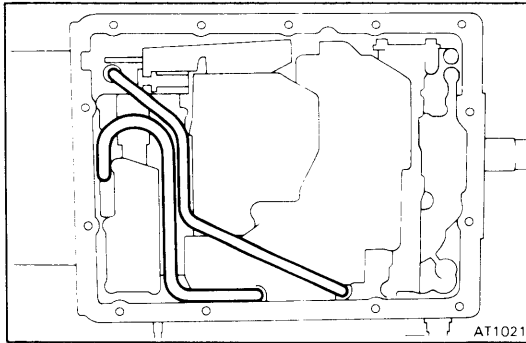
**16. TURN TRANSMISSION OVER AND REMOVE TUBES**

Pry up both tube ends with a large screwdriver and remove the tubes.

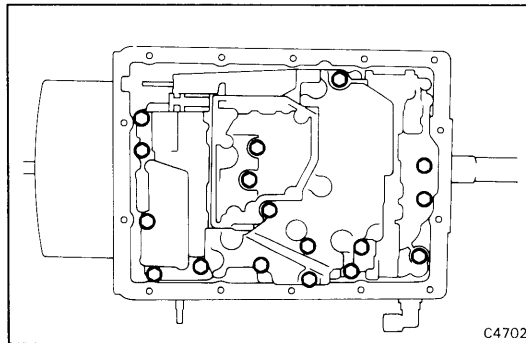
17. REMOVE STRAINER AND GASKET**18. REMOVE VALVE BODY**

(a) Remove the seventeen bolts.

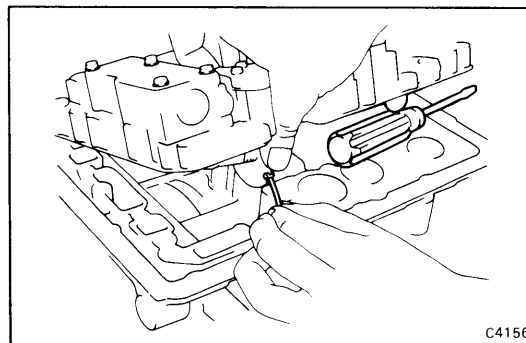

(b) Disconnect the throttle cable from the cam and remove the valve body.

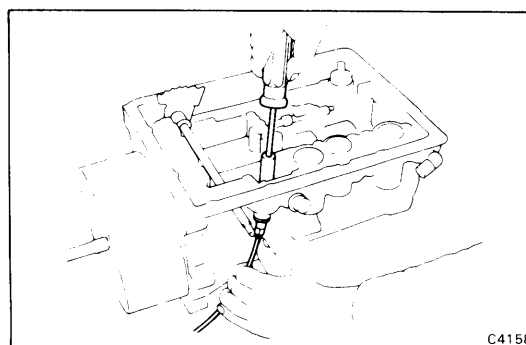
**19. REMOVE THROTTLE CABLE AND RETAINER**

Using a 10-mm socket, push the plastic throttle cable retainer out of the transmission case.

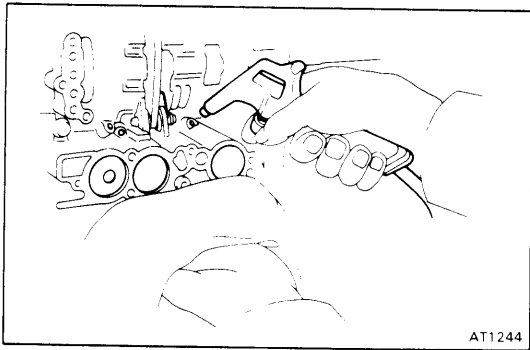

20. COVER PISTON WITH A RAG AND, REMOVE ACCUMULATOR PISTONS AND SPRINGS

WARNING: Keep face away to avoid injury. Do not use regular high-pressure air.

Position a rag to catch each piston. Using low-pressure compressed air (1 kg/cm², 14 psi, or 98 kPa, max.), pop each piston into the rag. Force air into the holes shown, and remove the pistons and springs.

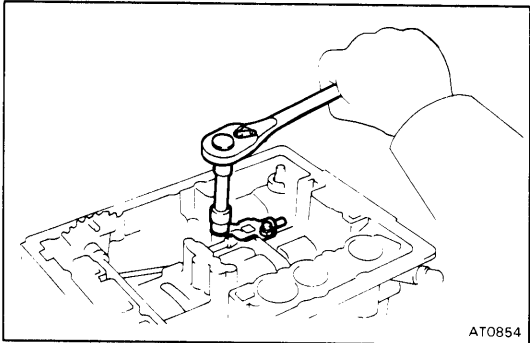

21. REMOVE PARKING LOCK PAWL BRACKET AND ROD

22. REMOVE SPRING, PIVOT PIN AND PARKING LOCK PAWL

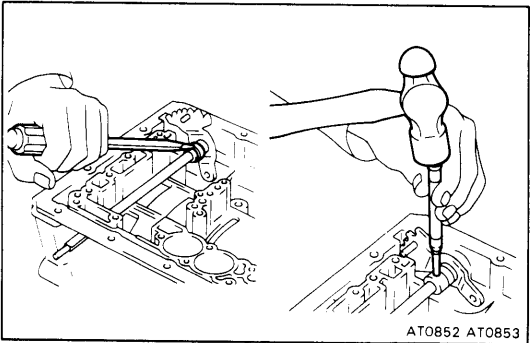

23. IF NECESSARY, REMOVE MANUAL LEVER AND SHAFT

- (a) Using a hammer and screwdriver, pry and shift the collar.
- (b) Using a hammer and punch, drive out the pin.
- (c) Slide the shaft out of the case and remove the detent plate.

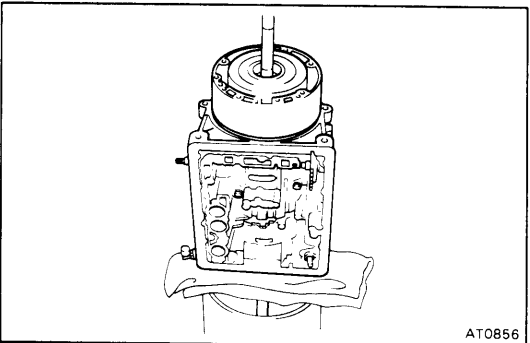

24. PLACE TRANSMISSION CASE ON CYLINDER

Place the transmission on a cylindrical stand for more efficient work.

CAUTION: Place shop rags between the case and stand to avoid damaging the case.

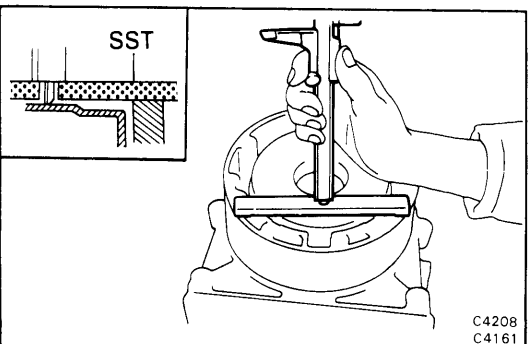

25. MEASURE DISTANCE BETWEEN TOP OF CASE AND CLUTCH DRUM

Set SST on the case as shown in the figure.

SST 09350-20015 (09370-12010)

Make a note of the distance for reassembly.

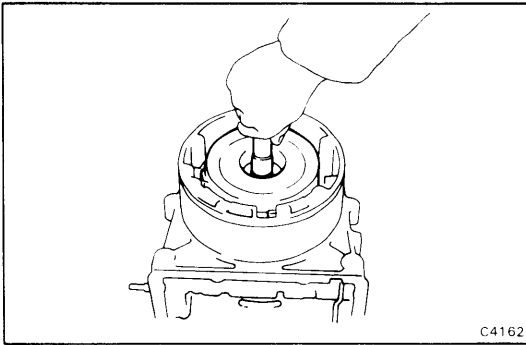

C4162

26. REMOVE OVERDRIVE CLUTCH

Grasp the shaft and pull out the overdrive clutch assembly. Be careful of the bearings and races on both sides of the assembly.

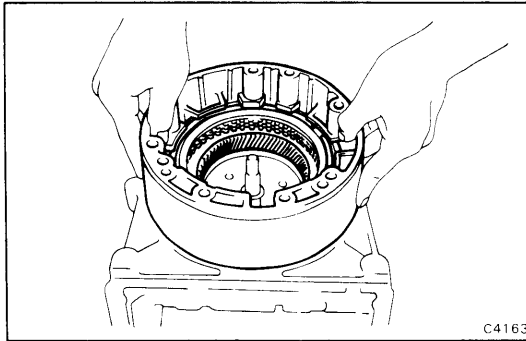

C4163

27. REMOVE OVERDRIVE CASE AND BRAKE

Hold both sides of the overdrive case and pull it out of the transmission case. Be careful of the bearings and races on both sides of the assembly.

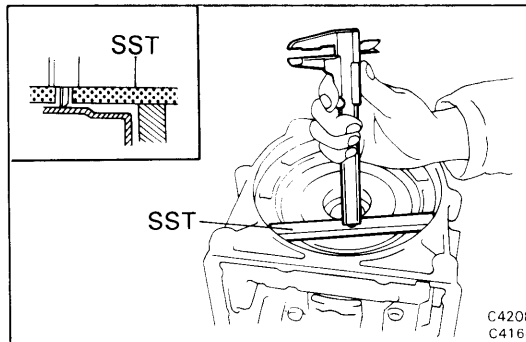
C4208
C4164**28. MEASURE DISTANCE BETWEEN TOP OF CASE FLANGE AND CLUTCH DRUM**

Set SST on the case as shown in the figure.

SST 09350-20015 (09370-12010)

Make a note of the distance for reassembly.

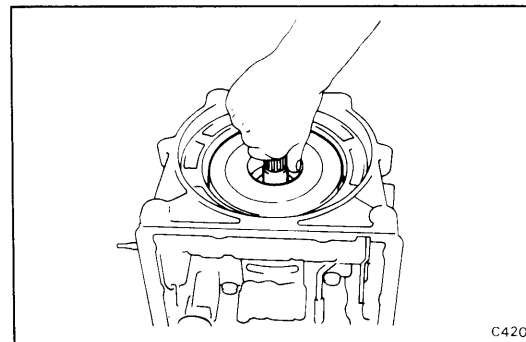

C4209

29. REMOVE FRONT CLUTCH AND BEARINGS

Grasp the shaft and pull out the front clutch assembly.

Be careful of the bearings and races on both sides of the assembly.

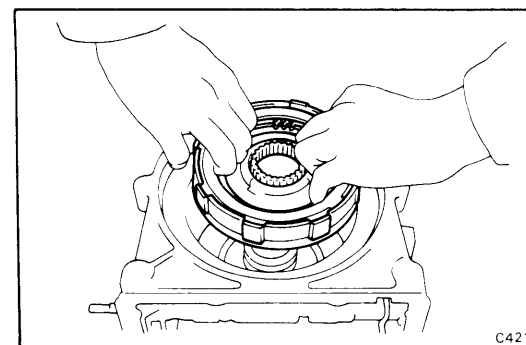
30. REMOVE BEARING AND RACE

C4210

31. REMOVE REAR CLUTCH

Grasp the clutch hub and pull it out of the case.

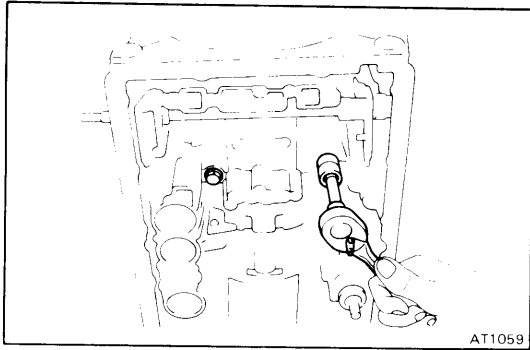

32. REMOVE CENTER SUPPORT AND SUN GEAR

(a) Remove the two center support bolts.

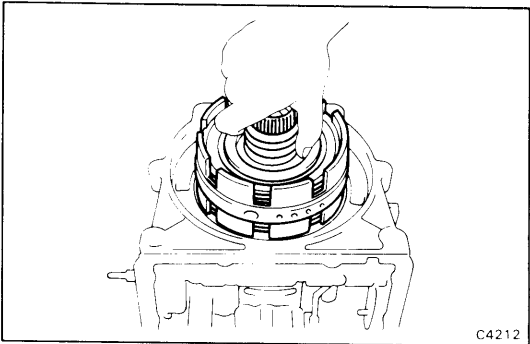

(b) Grasp the assembly and pull out the center support with the sun gear.

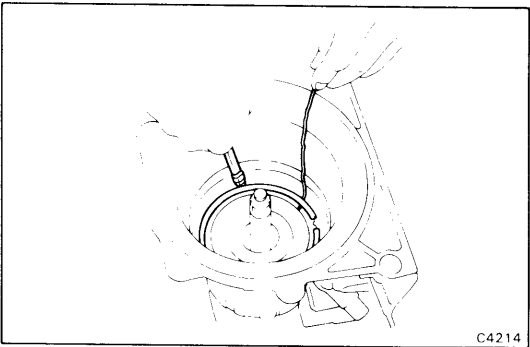

33. REMOVE REACTION PLATE RETAINING RING

Using a long screwdriver, compress the snap ring and lift it above the groove with a wire hook.

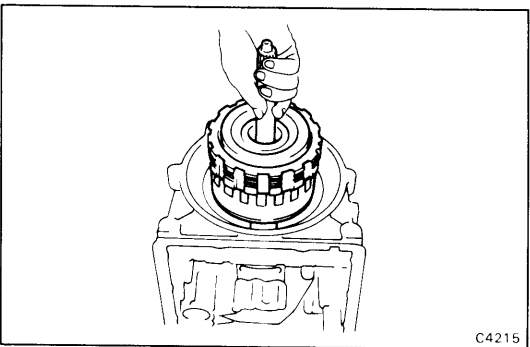

34. REMOVE REAR PARTS GROUP

Grasp the intermediate shaft and pull out the rear parts group.

If the brake apply tube and rear thrust bearing and races do not come out with the assembly, remove them from the case.

35. BASIC DISASSEMBLY IS COMPLETE

The transmission is now in basic component subassemblies. Next, you will disassemble, clean, inspect, repair and assemble each of these component groups.

COMPONENT GROUP DISASSEMBLY, INSPECTION AND ASSEMBLY

The instructions here are organized so that you work on only one component group at a time. This will help avoid confusion of similar-looking parts from different subassemblies being on your workbench at the same time. The component groups are inspected and repaired from the converter housing side.

As much as possible, complete the inspection, repair, assembly before proceeding to the next component group. If a component group cannot be assembled because parts are being ordered, be sure to keep all parts of that group in a separate container while proceeding with disassembly, inspection, repair and assembly of other component groups.

GENERAL CLEANING NOTES:

1. All disassembled parts should be washed clean and the fluid passages and holes blown through with compressed air to make sure they are not clogged.
2. Cleaning solvent used should be the recommended automatic transmission fluid or kerosene.
3. When using compressed air to dry parts, avoid spraying ATF or kerosene in your face.

PARTS HANDLING NOTES:

1. After cleaning, the parts should be arranged in proper order to allow performing the inspection, repairs, and reassembly with efficiency.
2. When disassembling a valve body, be sure to keep each valve together with the corresponding spring.
3. New brakes and clutches that are to be used for replacement must be soaked in transmission fluid for at least two hours before assembly.

GENERAL ASSEMBLY NOTES:

1. All oil seal rings, clutch discs, clutch plates, rotating parts, and sliding surfaces should be coated with transmission fluid prior to reassembly.
2. All gaskets and rubber O-rings should be replaced.
3. Make sure that the ends of a snap ring are not aligned with one of the cutouts and are installed in the groove correctly.
4. If a worn bushing is to be replaced, the replacement must be made with the subassembly containing that bushing.
5. Check thrust bearings and races for wear or damage. Replace if necessary.
6. Use petroleum jelly to keep parts in their places.

Oil Pump

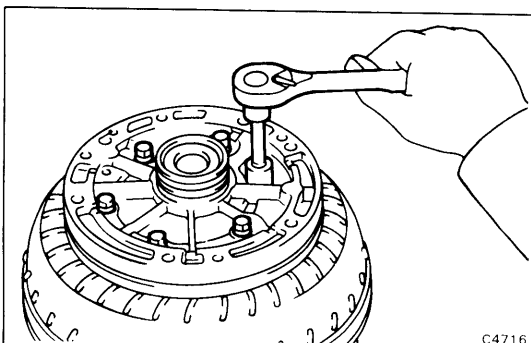
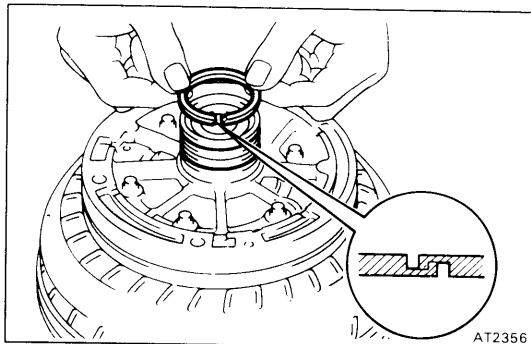
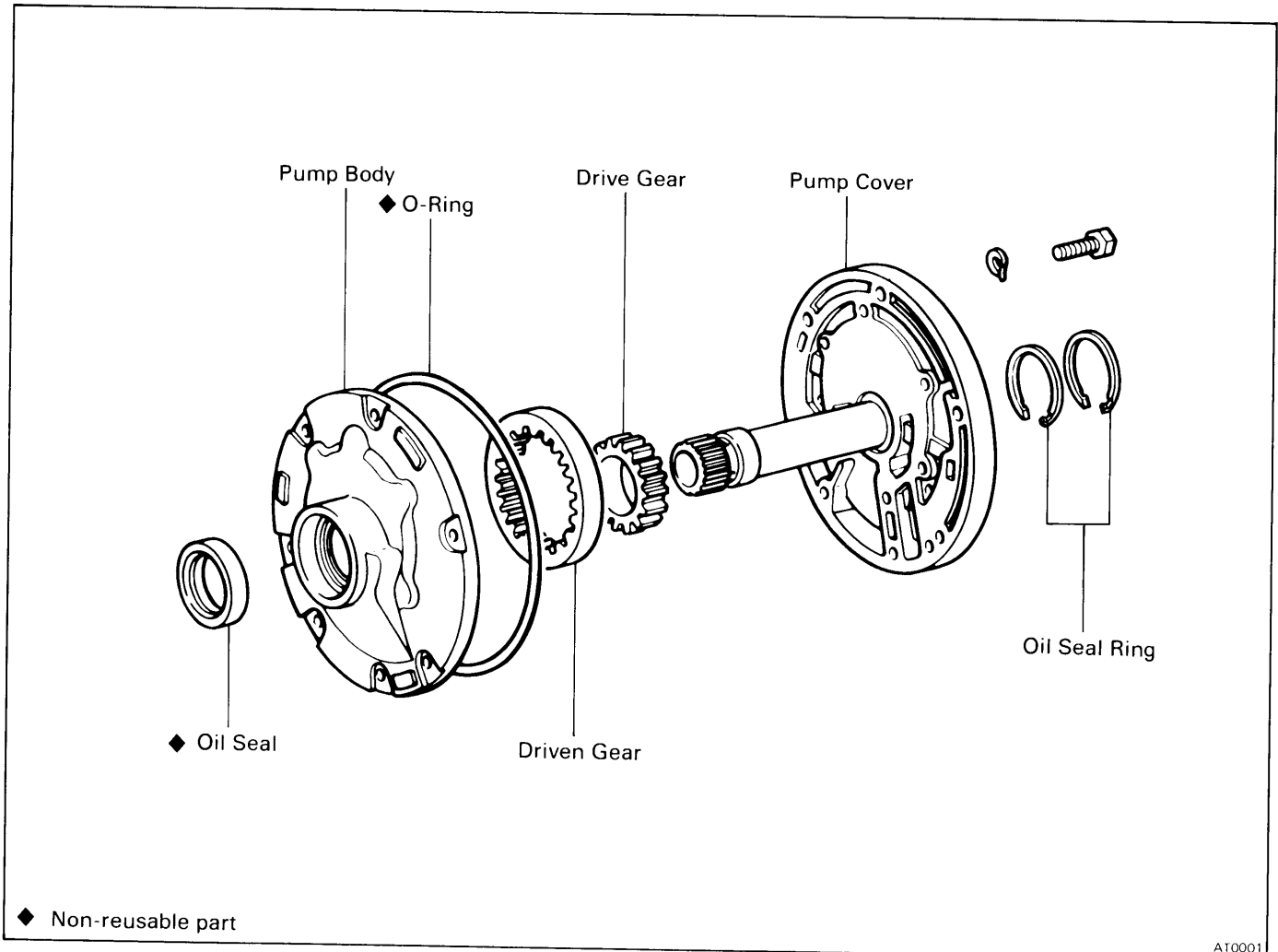

DISASSEMBLY OF OIL PUMP

1. USE TORQUE CONVERTER AS WORK STAND
2. REMOVE TWO OIL SEAL RINGS FROM PUMP COVER

3. REMOVE PUMP COVER

- (a) Remove the six bolts.
- (b) Remove the pump cover.

4. REMOVE O-RING FROM PUMP

5. LIFT PUMP OFF CONVERTER AND REMOVE OIL PUMP DRIVE GEAR AND DRIVEN GEAR

Identify the top and bottom and keep in assembly order.

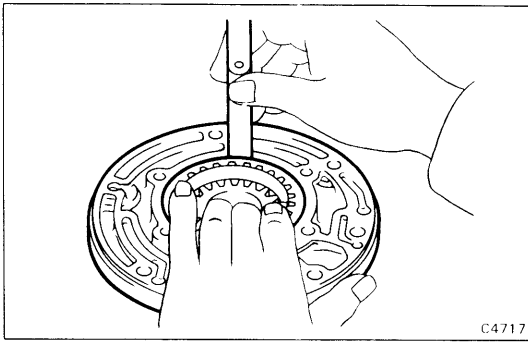

C4717

INSPECTION OF OIL PUMP

1. CHECK BODY CLEARANCE OF DRIVEN GEAR

Push the driven gear to one side of the body. Using a feeler gauge, measure the clearance.

Standard body clearance: 0.07 – 0.15 mm
(0.0028 – 0.0059 in.)

Maximum body clearance: 0.3 mm (0.012 in.)

If the body clearance is greater than maximum, replace the drive gear, driven gear or pump body.

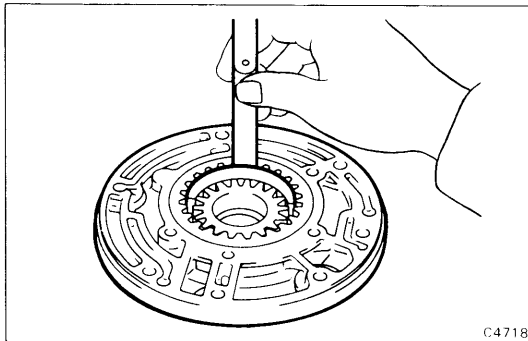

C4718

2. CHECK TIP CLEARANCE OF BOTH GEARS

Measure between the gear teeth and the crescent-shaped part of the pump body.

Standard tip clearance: 0.11 – 0.14 mm
(0.0043 – 0.0055 in.)

Maximum tip clearance: 0.3 mm (0.012 in.)

If the tip clearance is greater than maximum, replace the drive gear, driven gear or pump body.

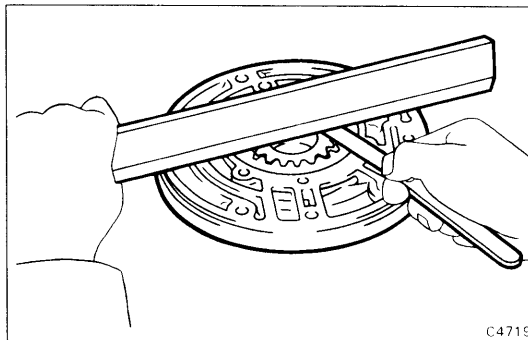

C4719

3. CHECK SIDE CLEARANCE OF BOTH GEARS

Using a steel straightedge and a feeler gauge, measure the side clearance of both gears.

Standard side clearance: 0.02 – 0.05 mm
(0.0008 – 0.0020 in.)

Maximum side clearance: 0.1 mm (0.004 in.)

If the side clearance is greater than maximum, replace the drive gear, drive gear or pump body.

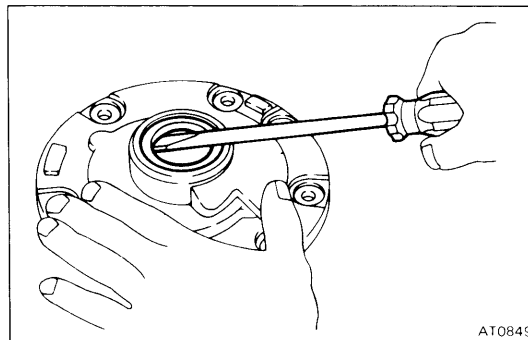

AT0849

4. INSPECT FRONT OIL SEAL

Check for wear, damage or cracks.

If necessary, replace the oil seal as follows.

(a) Pry off the oil seal with a screwdriver.

(b) Using SST and a hammer, tap in a new oil seal. The seal end should be flush with outer edge of pump body.

SST 09350-20015 (09388-20010)

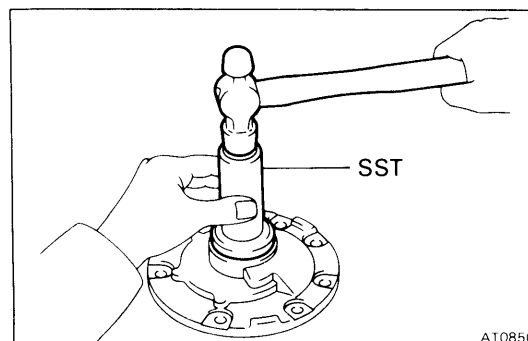

AT0850

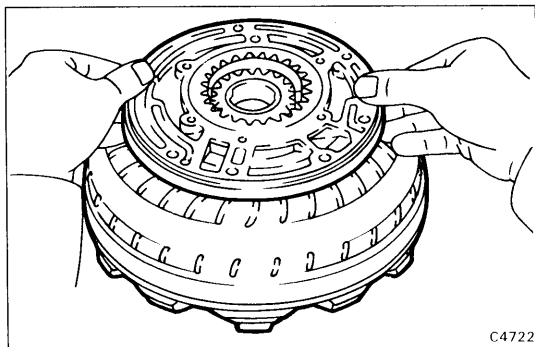

ASSEMBLY OF OIL PUMP

(See page AT-44)

- 1. INSTALL DRIVEN GEAR AND DRIVE GEAR AND SET PUMP BODY ON TORQUE CONVERTER**

Make sure the top of the gears is facing upward.

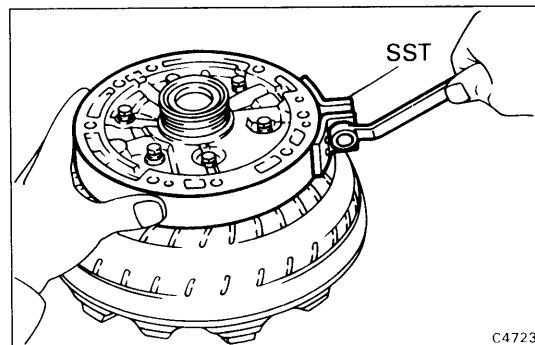

- 2. LOOSELY INSTALL PUMP COVER**

Align the bolt holes and drop the pump cover into the place. Install the six bolts with the wave washers finger tight.

- 3. ALIGN PUMP BODY AND PUMP COVER**

Install the SST around body and cover. Tighten SST to align the body and cover.

SST 09350-20015 (09363-20010)

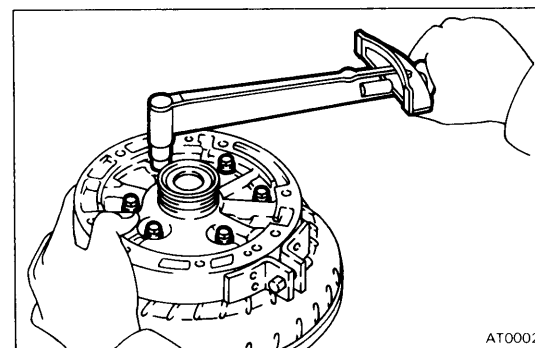

- 4. TIGHTEN SIX PUMP COVER BOLTS**

Torque: 75 kg-cm (65 in.-lb, 7.4 N·m)

- 5. REMOVE SST**

SST 09350-20015 (09363-20010)

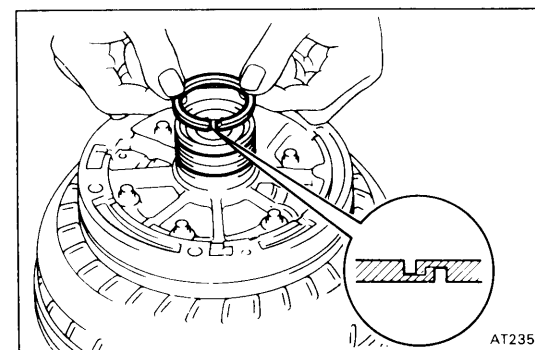

- 6. INSTALL TWO OIL SEAL RINGS ON PUMP COVER**

Spread apart and slide into the groove.

Hook both ends by hand.

Wipe off any excess petroleum jelly.

NOTE: After installing the oil seal rings, check that they move smoothly.

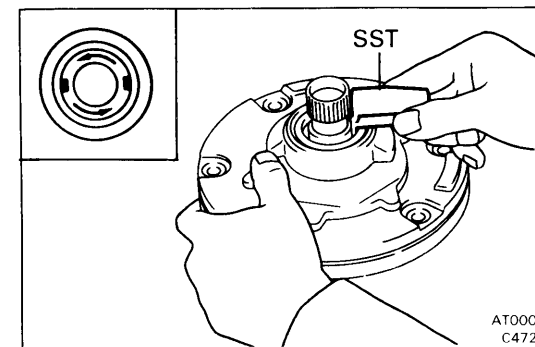

- 7. INSTALL NEW O-RING ON PUMP**

Make sure the O-ring is not twisted and is fully seated in the groove.

- 8. CHECK DRIVE GEAR ROTATION**

Turn the drive gear with SST and make sure it rotates smoothly.

SST 09350-20015 (09397-22020)

CAUTION: Be careful not to damage the oil seal lip.

Overdrive Input Shaft and Clutch

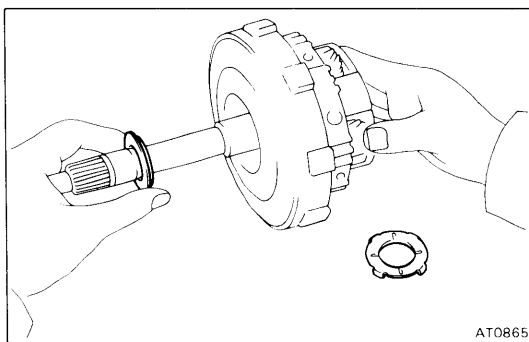
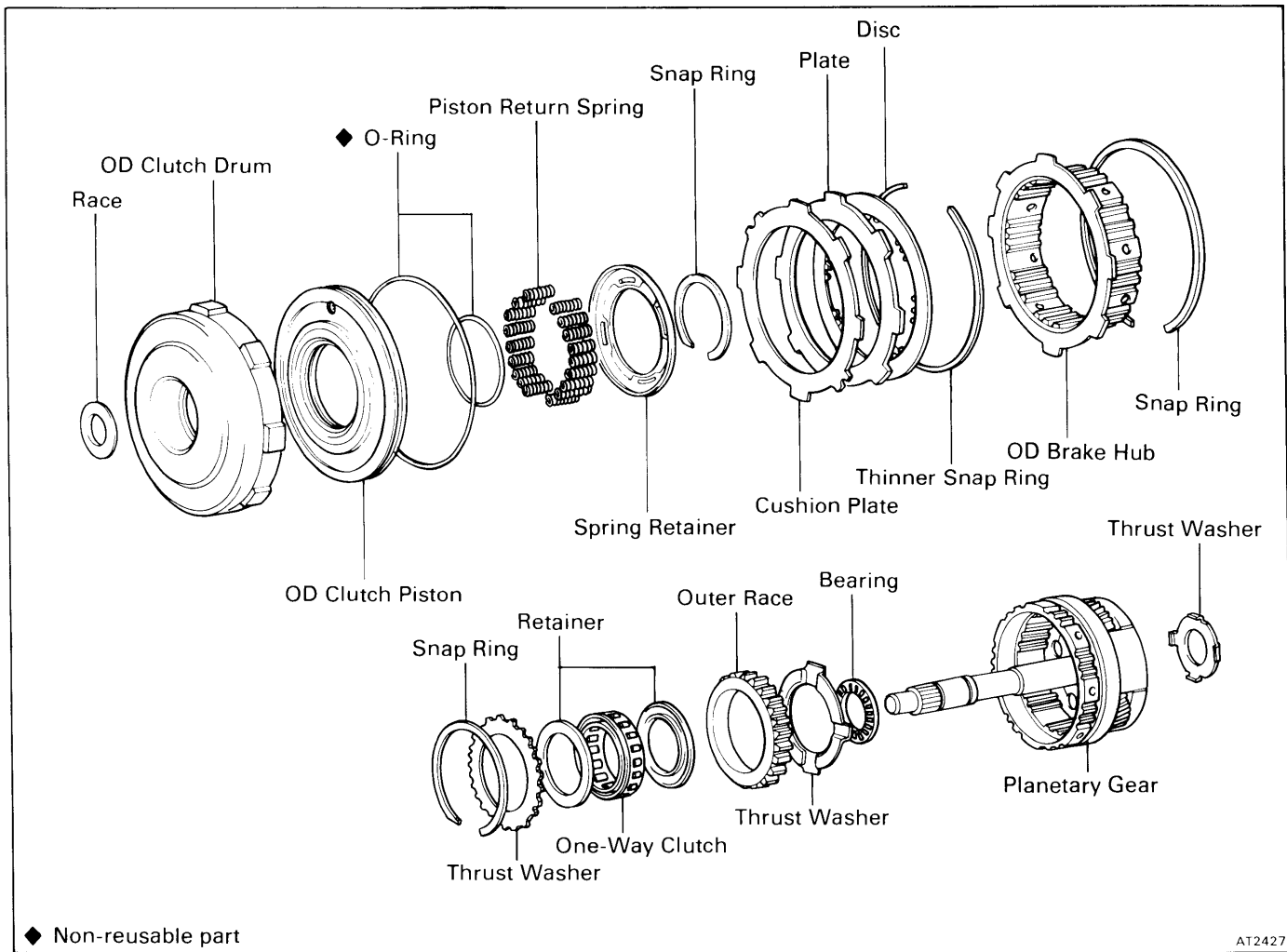

DISASSEMBLY OF OVERDRIVE INPUT SHAFT AND CLUTCH

1. REMOVE RACE FROM OVERDRIVE INPUT SHAFT

- (a) Slide off the race from the clutch side by hand. Note the position of the race.
- (b) Using a screwdriver, pry off the thrust washer from the planetary gear side.

2. PULL OVERDRIVE CLUTCH ASSEMBLY FROM INPUT SHAFT

CAUTION: Be careful that the thrust bearing and race do not fall out.

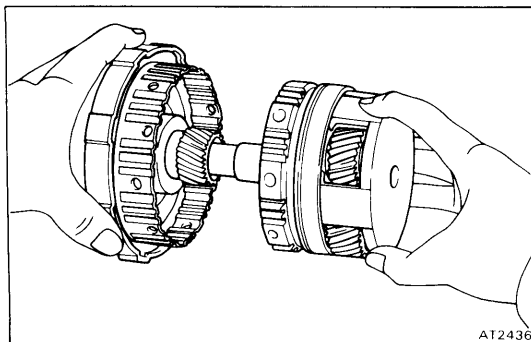

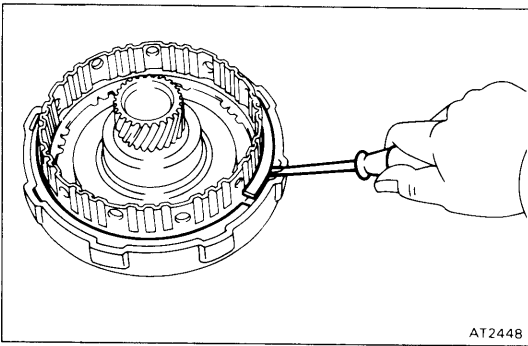

3. REMOVE SNAP RING AND HUB FROM OVERDRIVE CLUTCH ASSEMBLY
4. REMOVE DISC
5. REMOVE THINNER SNAP RING, PLATE AND CUSHION PLATE

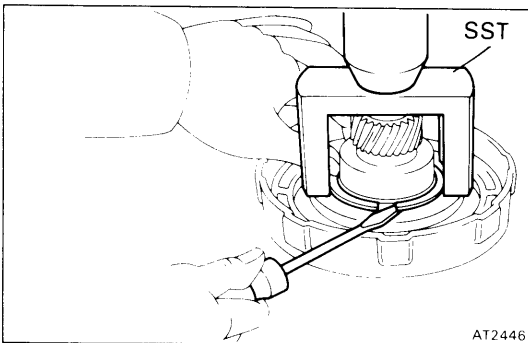

6. COMPRESS PISTON RETURN SPRINGS AND REMOVE SNAP RING
Place SST on the spring retainer and compress the springs with a shop press. Using a screwdriver, remove the snap ring.
SST 09350-20015 (09369-20040)

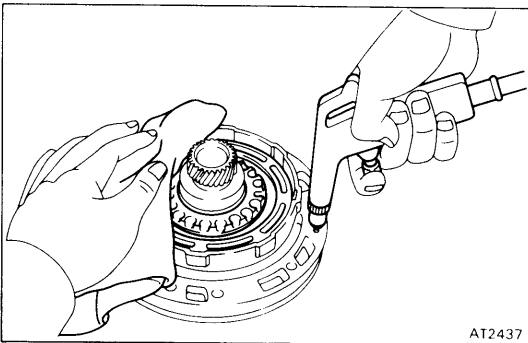

7. REMOVE SPRING RETAINER AND EIGHTEEN SPRINGS
8. ASSEMBLE OVERDRIVE CLUTCH ON OIL PUMP AND BLOW OUT PISTON
 - (a) Slide the overdrive clutch onto the oil pump.
 - (b) Apply compressed air to the oil pump to remove the piston. (If the piston does not come out completely, use needle-nose pliers to remove it.)
 - (c) Remove the overdrive clutch from the oil pump.

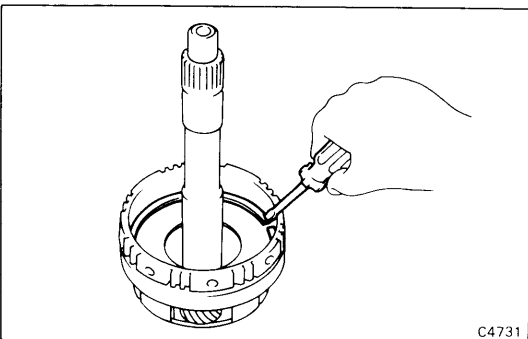

9. REMOVE CLUTCH PISTON O-RINGS
10. REMOVE SNAP RING FROM OVERDRIVE PLANETARY GEAR ASSEMBLY
11. REMOVE THRUST WASHERS AND ONE-WAY CLUTCH FROM PLANETARY GEAR ASSEMBLY
CAUTION: Be careful not to lose the four plugs.

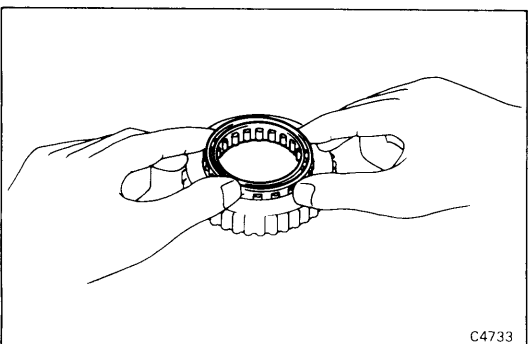

12. REMOVE BEARING
Note the direction of the bearing.
13. REMOVE ONE-WAY CLUTCH FROM OUTER RACE
Note the direction of the one-way clutch.

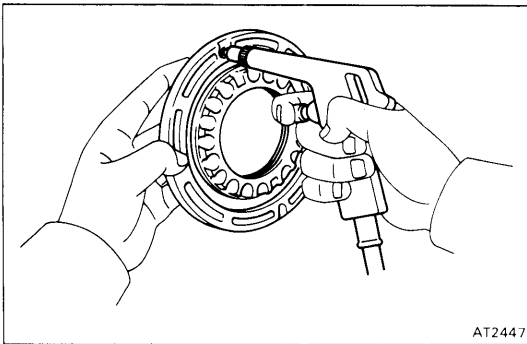

AT2447

INSPECTION OF OVERDRIVE INPUT SHAFT AND CLUTCH

1. INSPECT CLUTCH PISTON

- (a) Check that the check ball is free by shaking the piston.
- (b) Check that the valve does not leak by applying low-pressure compressed air.

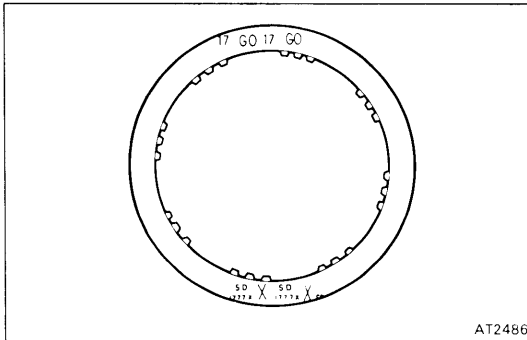

AT2486

2. INSPECT DISC, PLATE AND CLUTCH HUB

Check that the sliding surface of disc is not worn or burnt. If the disc is worn or burnt, replace the disc.

Then check that the sliding surfaces of plate and hub are not worn or burnt.

If necessary, replace them.

NOTE: Do not allow the disc to dry out.

Prepare a new disc by soaking it at least two hours in ATF.

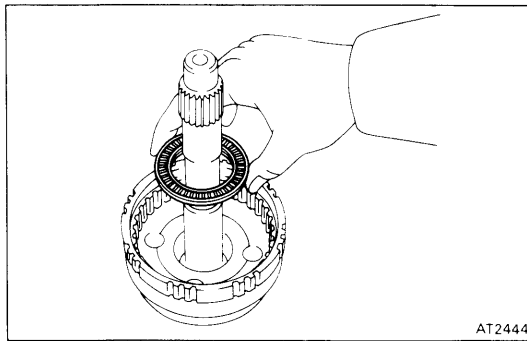

AT2444

ASSEMBLY OF OVERDRIVE INPUT SHAFT AND CLUTCH

(See page AT-47)

1. INSTALL BEARING

- (a) Coat part with petroleum jelly to keep it in place.
- (b) Slip in the bearing as shown in the figure.

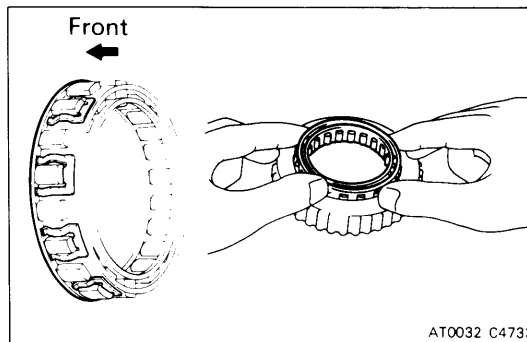

AT0032 C4733

2. INSTALL ONE-WAY CLUTCH

- (a) Install the one-way clutch into the outer race.
- (b) Install the retainer on both sides of the one-way clutch.

NOTE: Remember that the spring cage side of the one-way clutch faces toward the front of the transmission.

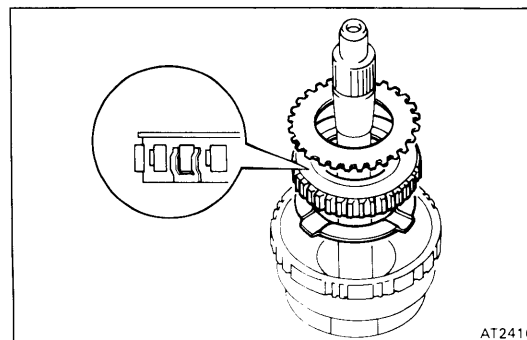

AT2416

3. INSTALL THRUST WASHER AND ONE-WAY CLUTCH

- (a) Install the thrust washer, facing the grooves upward.
- (b) Install the one-way clutch in correct direction.
- (c) Install the thrust washer.
- (d) Install the snap ring.

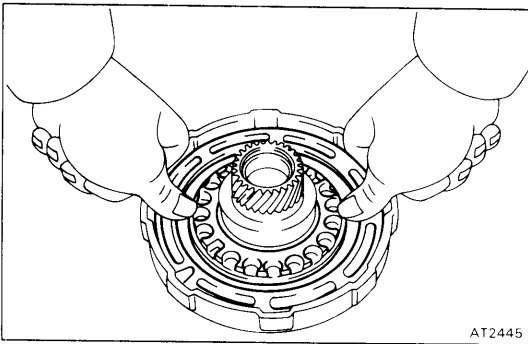

4. **INSTALL CLUTCH PISTON IN OVERDRIVE CLUTCH DRUM**
 - (a) Install new O-rings on the piston. Coat the O-rings with ATF.
 - (b) Press the piston into the drum with the cup side up, being careful not to damage the O-rings.

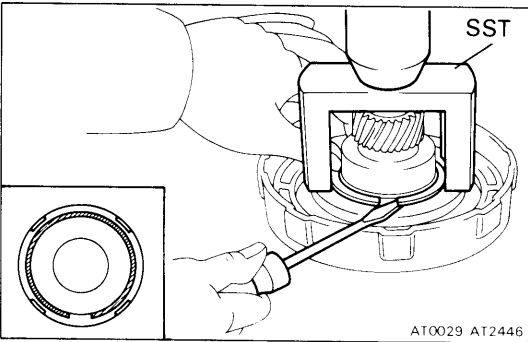

5. **INSTALL EIGHTEEN PISTON RETURN SPRINGS AND SPRING RETAINER AND SNAP RING IN PLACE**
6. **COMPRESS RETURN SPRINGS AND INSTALL SNAP RING IN GROOVE**
 - (a) Place SST on the spring retainer, and compress the springs on a shop press.
SST 09350-20015 (09369-20040)
 - (b) Using a screwdriver, install the snap ring. Be sure the end gap of snap ring is not aligned with the spring retainer claw.

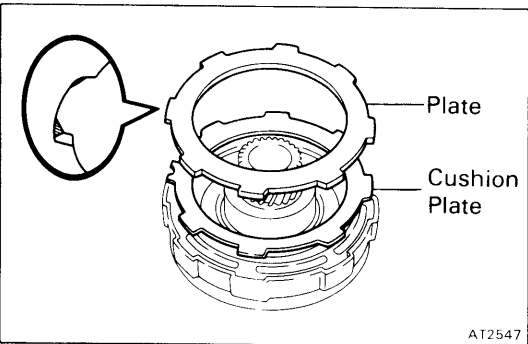

7. **INSTALL CUSHION PLATE AND PLATE**

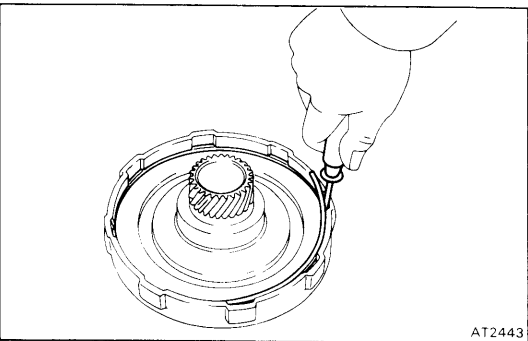

8. **INSTALL THINNER SNAP RING IN OVERDRIVE CLUTCH DRUM**

Compress and lower the snap ring into the groove by hand. Check that the ends of the snap ring are not aligned with one of the cutouts.

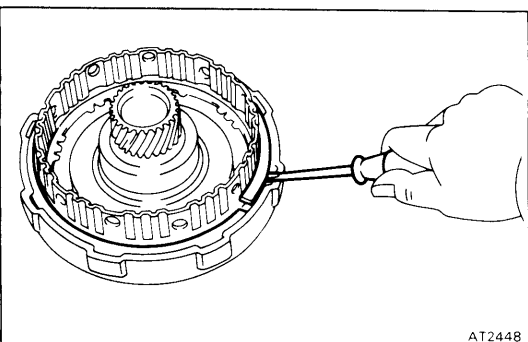

9. **INSTALL DISC**

Using low-pressure compressed air, blow all excess ATF from the disc.

CAUTION: High-pressure air will damage the disc.
10. **INSTALL HUB AND OUTER SNAP RING**

Check that the ends of the snap ring are not aligned with one of the cutouts.

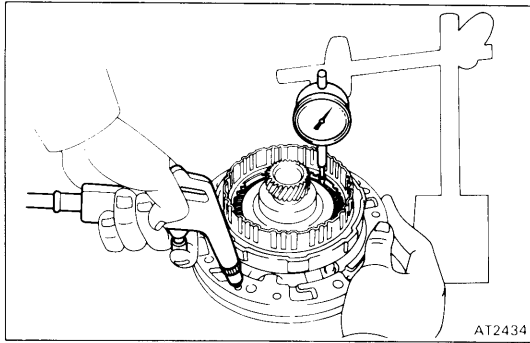

11. CHECK PISTON STROKE OF OVERDRIVE CLUTCH

Install the front clutch drum onto the oil pump body. Using a dial indicator as shown, measure the stroke applying and releasing the compressed air (4 — 8 kg/cm², 57 — 114 psi or 392 — 785 kPa).

**Standard piston stroke: 1.77 — 2.58 mm
(0.0697 — 0.1016 in.)**

If the stroke exceeds the limit, the clutch pack is probably worn. If the stroke is less than the limit, parts may be misassembled or there may be excess ATF on the disc.

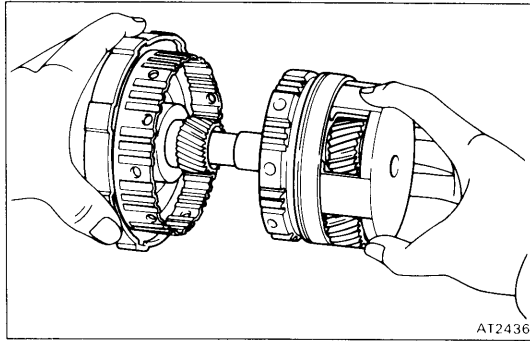

12. ASSEMBLE OVERDRIVE CLUTCH DRUM AND OVERDRIVE PLANETARY GEAR

Mesh the hub with the disc, twisting and jiggling the hub as required.

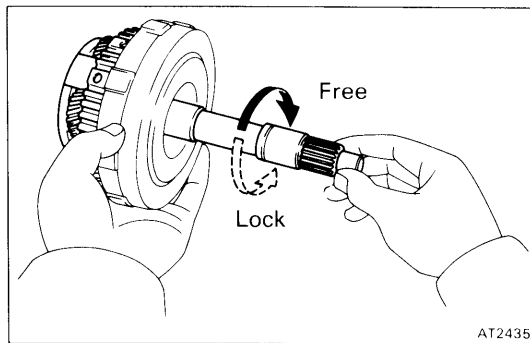

13. CHECK OPERATION OF ONE-WAY CLUTCH

Hold the clutch drum and turn the input shaft. The input shaft should turn freely clockwise and should lock counterclockwise.

14. KEEP THRUST WASHER AND RACE

Overdrive Case and Brake

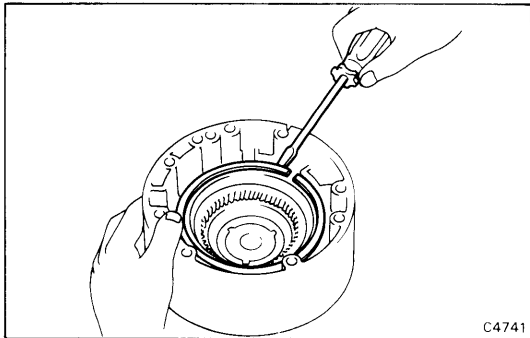
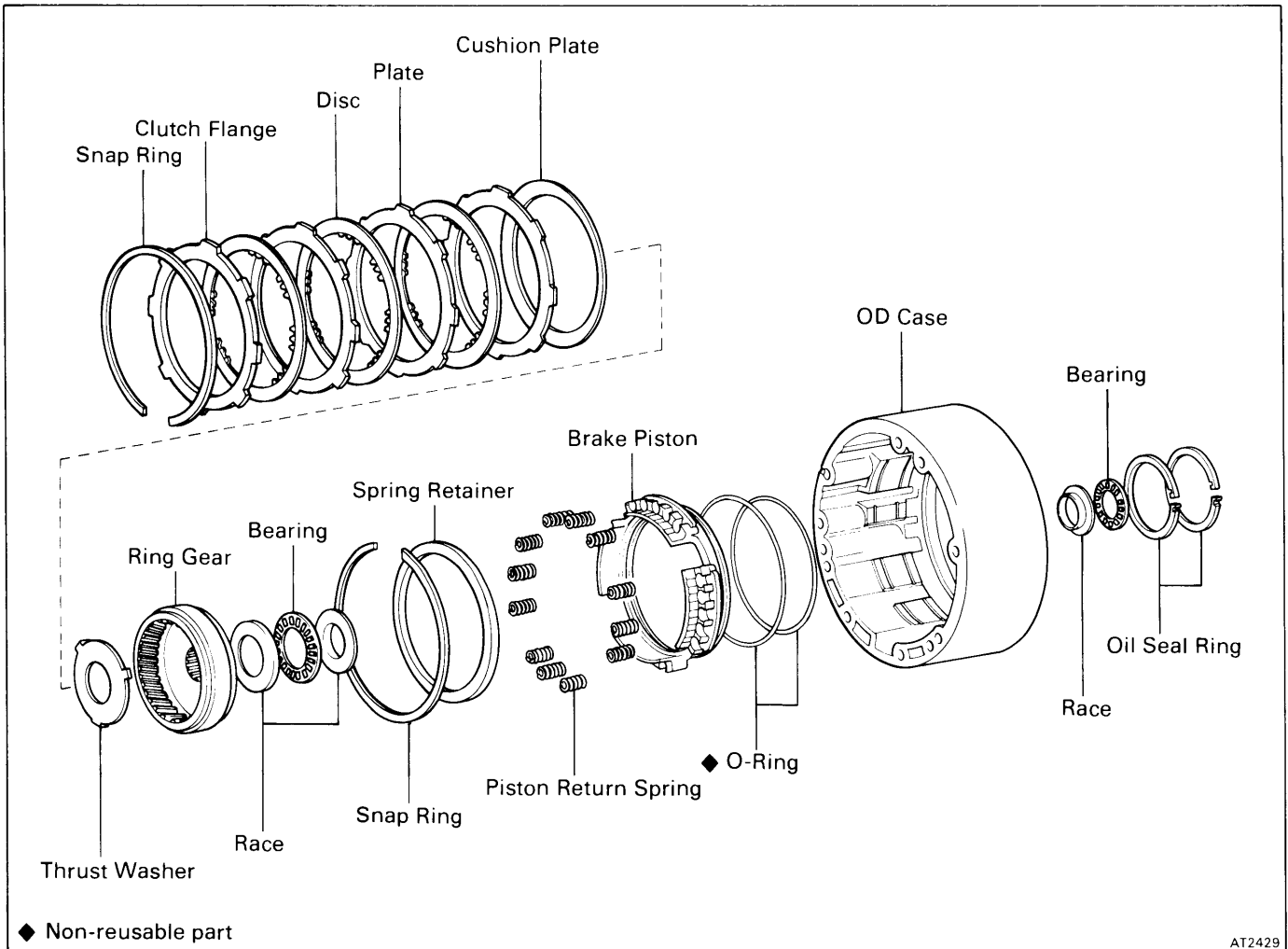

DISASSEMBLY OF OVERDRIVE CASE AND BRAKE

1. REMOVE OUTER SNAP RING FROM OVERDRIVE CASE
2. REMOVE CLUTCH FLANGE, DISCS PLATES AND CUSHION PLATE

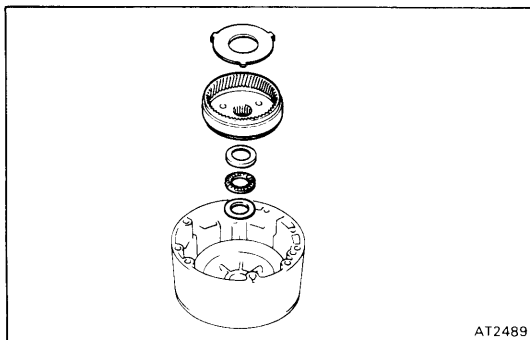

3. REMOVE RING GEAR AND THRUST WASHER
4. REMOVE THRUST BEARING AND RACES FROM OVERDRIVE CASE

Note the position of the races.

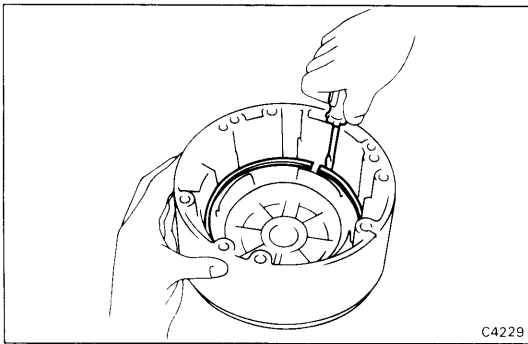

- 5. REMOVE SNAP RING, SPRING RETAINER AND RETURN SPRINGS**

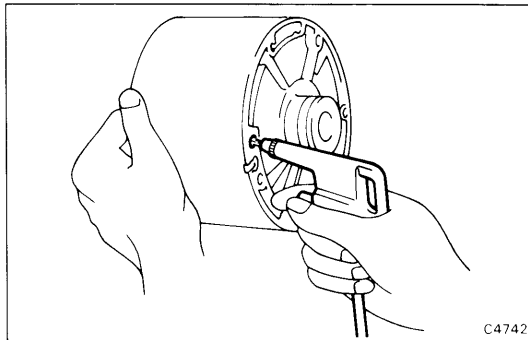

- 6. REMOVE BRAKE PISTON**

Blow compressed air through the case hole indicated in the figure to pop out the brake piston.

If piston does not pop out, lift it out with needle nose pliers.

- 7. REMOVE TWO OIL SEAL RINGS FROM OVERDRIVE CASE**

- 8. REMOVE O-RINGS FROM PISTON**

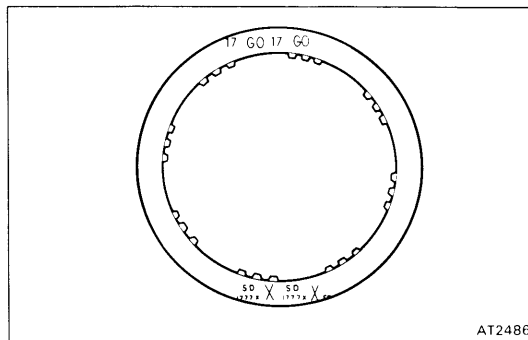

INSPECTION OF OVERDRIVE CASE AND BRAKE

INSPECT DISC, PLATE AND FLANGE

Check that the sliding surface of disc is not worn or burnt. If a disc is worn or burnt, replace all discs.

Then check that the sliding surfaces of plate and flange are not worn or burnt.

If necessary, replace them.

NOTE: Do not allow the discs to dry out.

Prepare new discs by soaking them at least two hours in ATF.

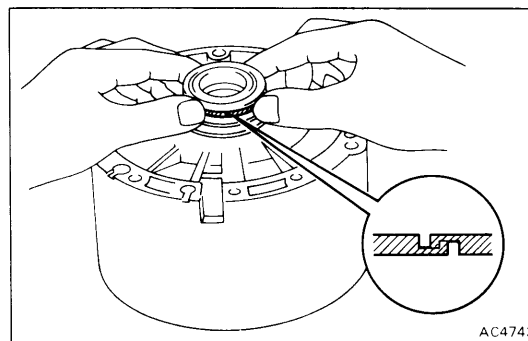

ASSEMBLY OF OVERDRIVE CASE AND BRAKE

(See page AT-52)

- 1. INSTALL TWO OIL SEAL RINGS ON OVERDRIVE CASE**

Spread apart and slide the rings into the groove. Hook both ends by hand.

NOTE: After installing the oil seal rings, check that they move smoothly.

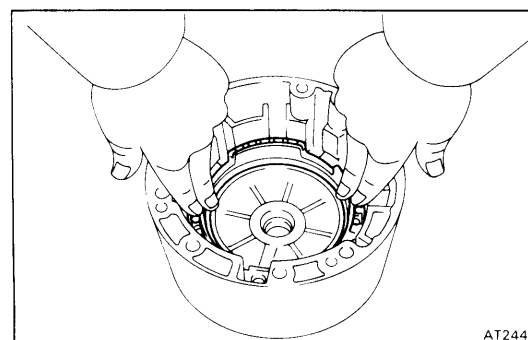

- 2. INSTALL NEW O-RINGS ON PISTON**

- 3. INSTALL BRAKE PISTON IN OVERDRIVE CASE**

Install the piston with the cup side up, being careful not to damage the O-rings.

- 4. INSTALL RETURN SPRINGS AND SPRING RETAINER AND SNAP RING IN PLACE**

Check that the ends of snap ring are not aligned with one of the cutouts.

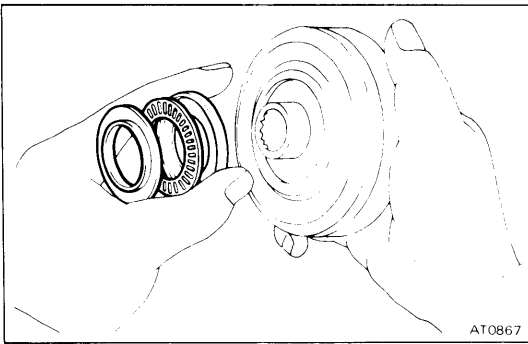

5. INSTALL THRUST BEARING AND RACES TO RING GEAR, AND SET RING GEAR IN OVERDRIVE CASE

NOTE: Make sure that the races are installed in correct direction.

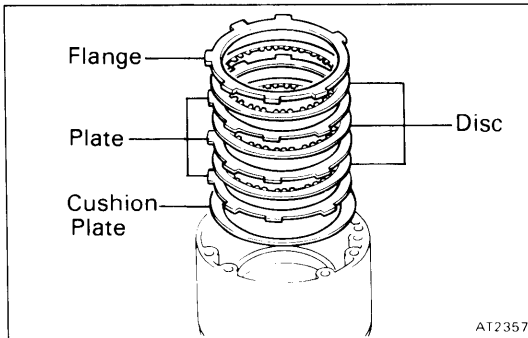

6. INSTALL CUSHION PLATE, DISCS, PLATES AND FLANGE

Using low-pressure compressed air, blow all excess ATF from the discs.

CAUTION: High-pressure air will damage the discs.

Install in order: Cushion plate (rounded end down)-plate-disc-plate-disc-plate-disc-flange

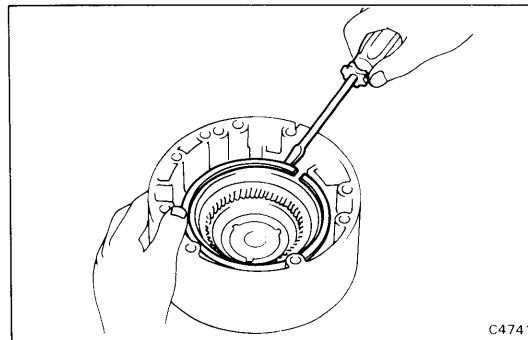

7. INSTALL SNAP RING

Check that the ends of the snap ring are not aligned with one of the cutouts.

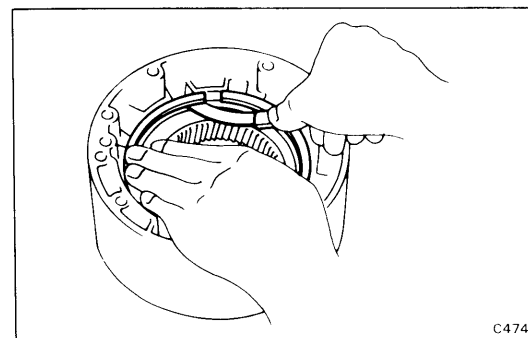

8. MEASURE BRAKE CLEARANCE

Measure the distance between the snap ring and flange.

Standard clearance: 0.65 – 2.21 mm
(0.0256 – 0.0870 in.)

9. KEEP THRUST WASHER FOR ASSEMBLY

The thrust washer left over will be installed later, as the transmission is assembled.

Front Clutch

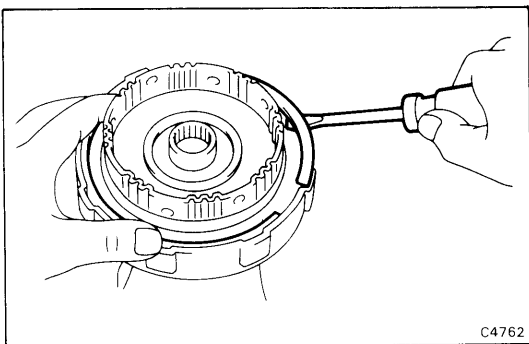
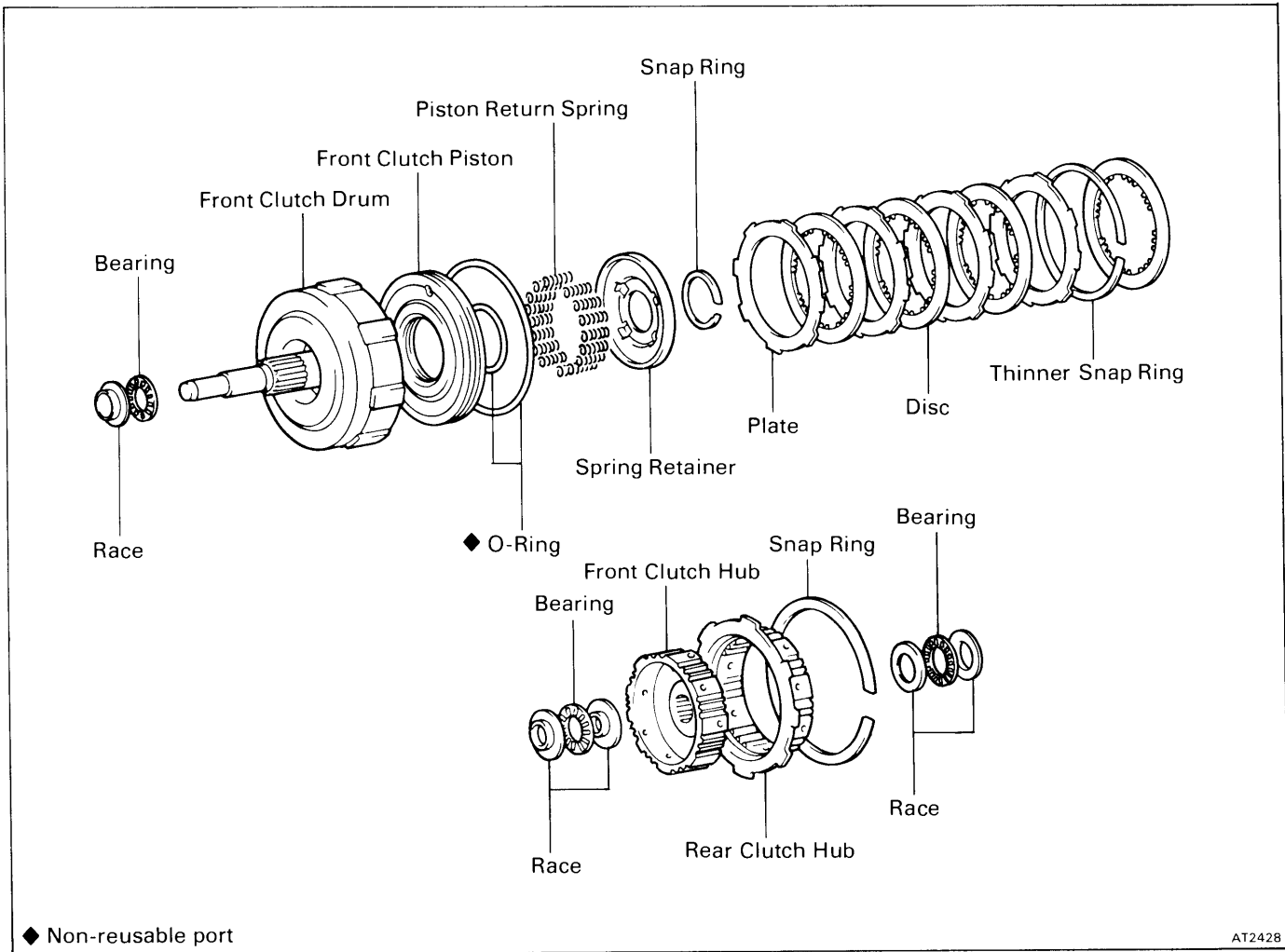

DISASSEMBLY OF FRONT CLUTCH

- 1. REMOVE THRUST BEARINGS AND RACES FROM BOTH SIDES OF CLUTCH**

Note the position of the races.

- 2. REMOVE SNAP RING FROM FRONT CLUTCH DRUM**

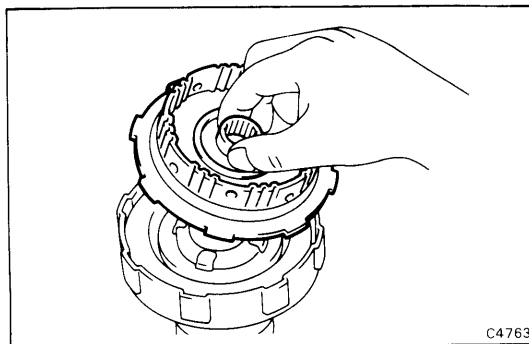

- 3. REMOVE FRONT AND REAR CLUTCH HUB**

Lift out the two clutch hubs together.

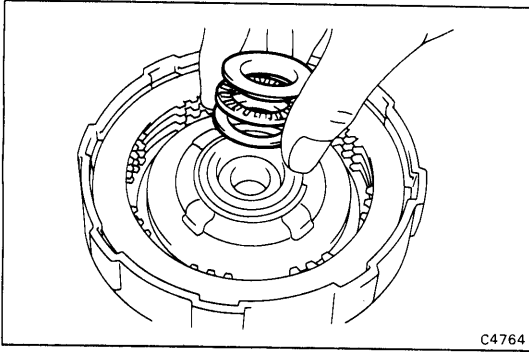

4. REMOVE THRUST BEARING AND RACES

Note the position of the races.

5. REMOVE DISC

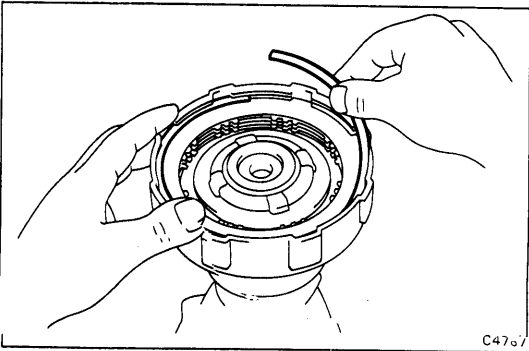

6. REMOVE THINNER SNAP RING

7. REMOVE REMAINING CLUTCH PLATES AND DISCS

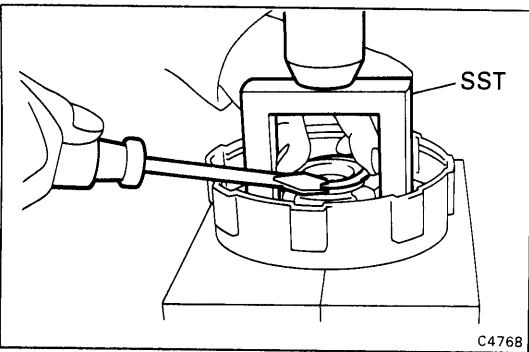

8. COMPRESS PISTON RETURN SPRINGS AND REMOVE SNAP RING

Place SST on the spring retainer and compress the springs with a shop press.

Using a screwdriver, remove the snap ring.

SST 09350-20015 (09369-20040)

9. REMOVE SPRING RETAINER AND TWENTY SPRINGS

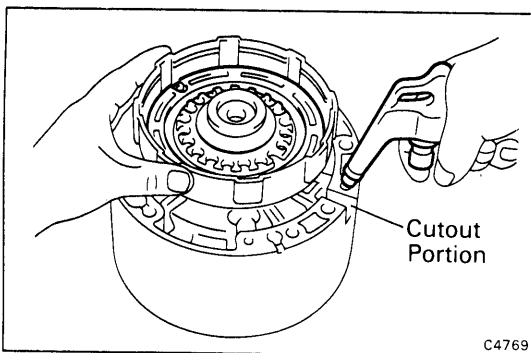

10. ASSEMBLE FRONT CLUTCH ON OVERDRIVE CASE AND BLOW OUT PISTON

- Slide the front clutch onto the overdrive case.
- Apply compressed air to the overdrive case to remove the piston. (If piston does not come out completely, use needle-nose pliers to remove it.)
- Remove the front clutch from the overdrive case.

11. REMOVE O-RINGS FROM PISTON

INSPECTION OF FRONT CLUTCH

1. INSPECT FRONT CLUTCH PISTON

- Check that check ball is free by shaking the piston.
- Check that the valve does not leak by applying low-pressure compressed air.

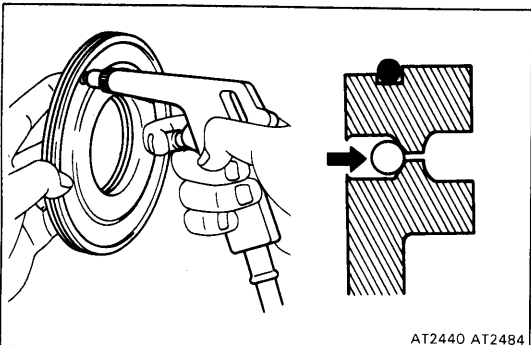

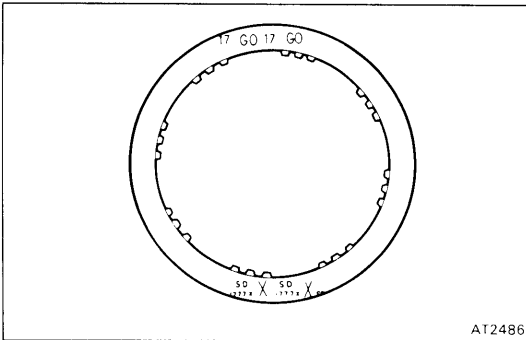

AT2486

2. INSPECT DISC, PLATE AND FLANGE

Check that the sliding surface of disc is not worn or burnt.

If the disc is worn or burnt, replace all discs.

Then check that the sliding surfaces of plate and flange are not worn or burnt.

If necessary, replace them.

NOTE: Do not allow the discs to dry out. Prepare new discs by soaking them at least two hours in ATF.

ASSEMBLY OF FRONT CLUTCH

(See page AT-55)

1. INSTALL NEW O-RINGS ON PISTON

2. INSTALL PISTON IN FRONT CLUTCH DRUM

Press the piston into the housing with the cup side up (check ball down).

Be careful not to damage the O-rings.

3. INSTALL TWENTY PISTON RETURN SPRINGS, SPRING RETAINER AND SNAP RING IN PLACE

4. COMPRESS RETURN SPRINGS AND INSTALL SNAP RING IN GROOVE

(a) Place SST on the spring retainer, and compress the springs on a shop press.

SST 09350-20015 (09369-20040)

(b) Using a screwdriver, install snap ring.

Be sure the end gap of the snap ring is not aligned with the spring retainer claw.

5. INSTALL DISCS AND PLATES WITHOUT ASSEMBLING THINNER SNAP RING

(a) Do not assemble the thinner snap ring yet.

(b) Using low-pressure compressed air, blow all excess ATF from the discs. For measurement of the clutch pack, install all plates and discs (temporarily without thinner snap ring).

CAUTION: High-pressure air will damage the discs.

Install in order: Plate-disc-plate-disc-plate-disc-plate-disc

6. CHECK PISTON STROKE OF FRONT CLUTCH

(a) Install the rear clutch hub and outer snap ring.

(b) Install the front clutch drum onto the overdrive case. Using a dial indicator as shown, measure the stroke applying and releasing the compressed air (4 – 8 kg/cm², 57 – 114 psi or 392 – 785 kPa).

Standard piston stroke: 1.32 – 2.66 mm
(0.0520 – 0.1047 in.)

If the stroke exceeds the limit, the clutch pack is probably worn. If the stroke is less than the limit, parts may be misassembled or there may be excess ATF on the discs.

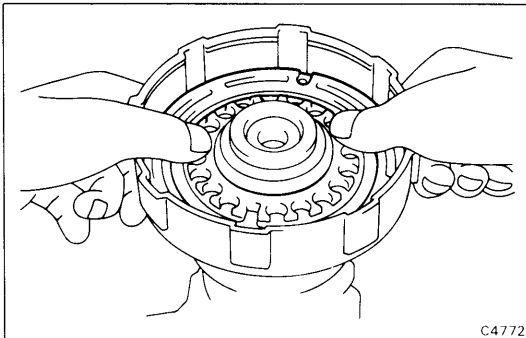

C4772

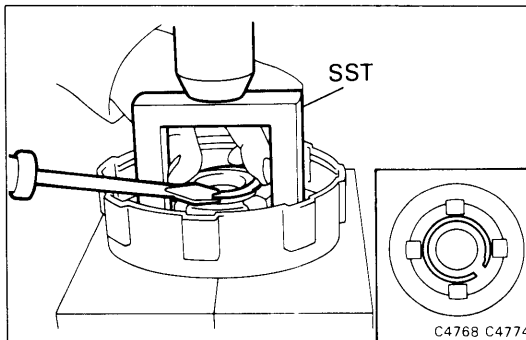

C4768 C4774

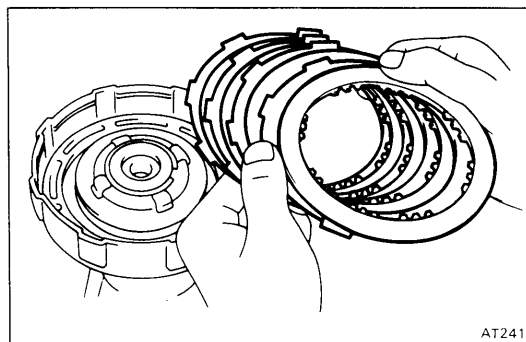

AT2417

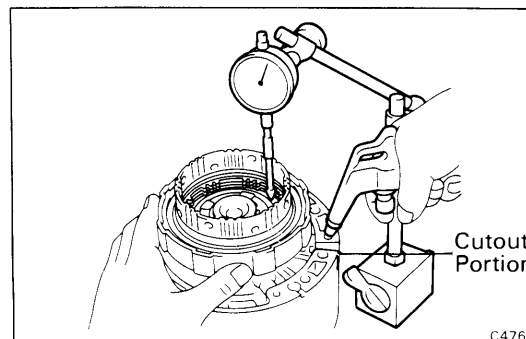

C4766

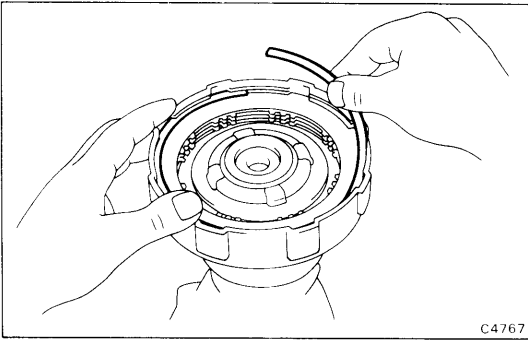

7. INSTALL THINNER SNAP RING IN CLUTCH DRUM

- (a) Remove the snap ring and rear clutch hub to allow installation of the inner snap ring.
- (b) Compress and lower into groove by hand. Check that the ends of the snap ring are not aligned with one of the cutouts.

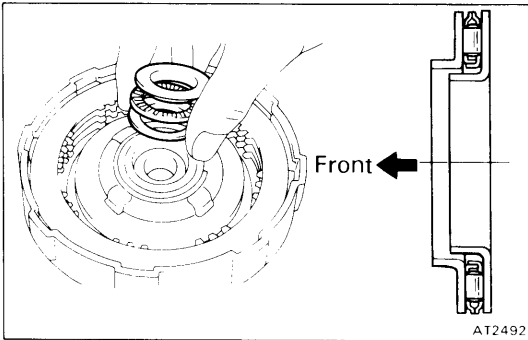

8. INSTALL INNER THRUST BEARING AND RACES

IMPORTANT: Coat parts with petroleum jelly to keep them in place.

Install the inner race, needle bearing and outer race. Press them into place.

NOTE: Face the race lip toward the front clutch body.

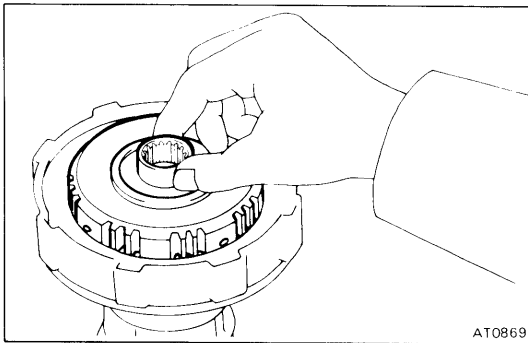

9. INSTALL FRONT CLUTCH HUB

Align the disc lugs with the hub teeth. Make sure the hub meshes with all the discs and is fully inserted.

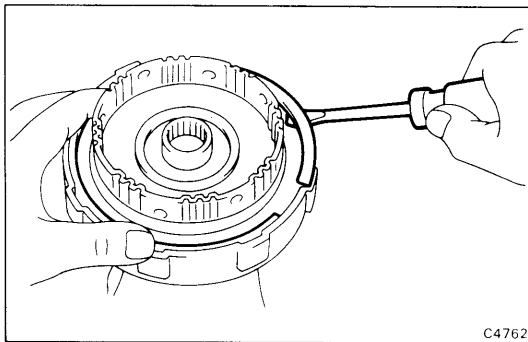

10. INSTALL REAR CLUTCH HUB AND OUTER SNAP RING

Check that the snap ring ends are not aligned with one of the cutouts.

NOTE: Note the position of the thrust bearing and races, and keep them together until assembly.

11. KEEP THRUST BEARINGS AND RACES TOGETHER

Rear Clutch

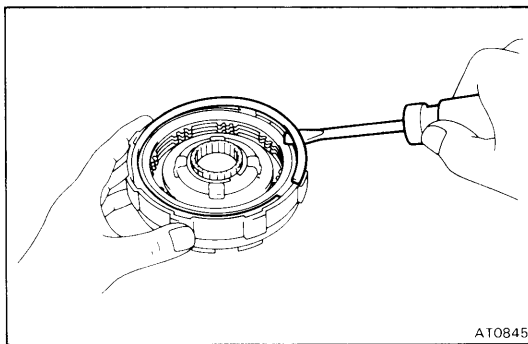
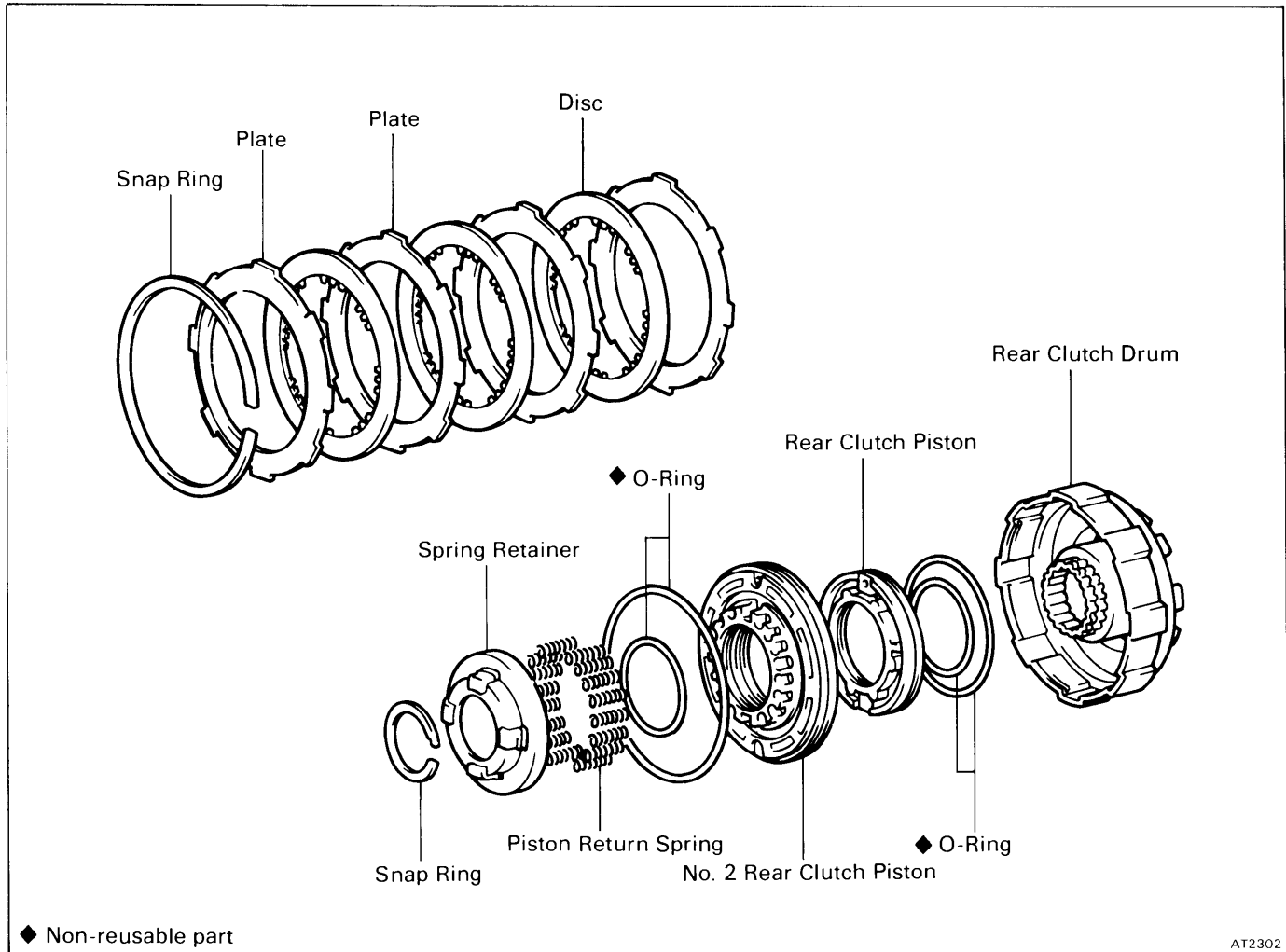

DISASSEMBLY OF REAR CLUTCH

1. REMOVE SNAP RING FROM DRUM
2. REMOVE CLUTCH FLANGE, DISCS AND PLATES

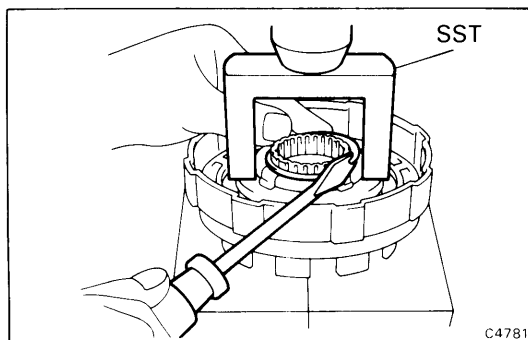

3. COMPRESS PISTON RETURN SPRINGS AND REMOVE SNAP RING

Place SST on the spring retainer and compress the springs with a shop press.

Using a screwdriver, remove the snap ring.

SST 09350-20015 (09369-20040)

4. REMOVE SPRING RETAINER AND EIGHTEEN RETURN SPRINGS

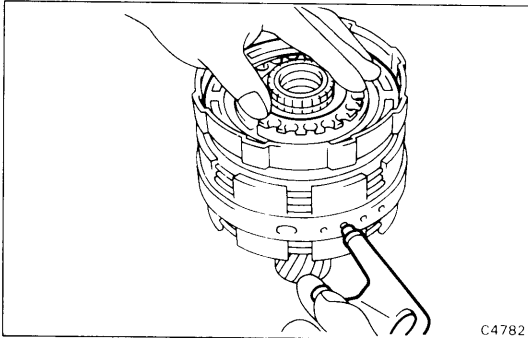

C4782

5. ASSEMBLE REAR CLUTCH ON CENTER SUPPORT AND BLOW OUT PISTONS

- Slide the rear clutch onto the center support.
- Apply compressed air to the center support to remove the piston. (If the piston does not come out completely, use pliers to remove it.)
- Remove the rear clutch from the center support.

6. REMOVE O-RINGS FROM REAR CLUTCH PISTONS

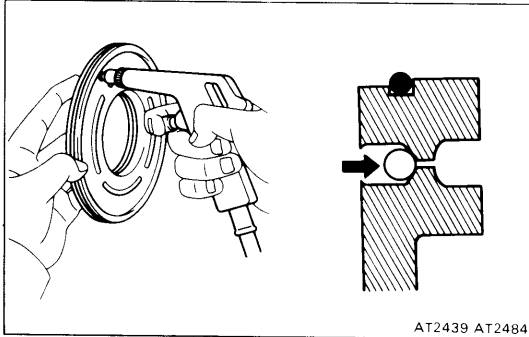

AT2439 AT2484

INSPECTION OF REAR CLUTCH

1. INSPECT REAR CLUTCH PISTON

- Check that check ball is free by shaking each piston.
- Check that the valve does not leak by applying low-pressure compressed air.

2. INSPECT DISC, PLATE AND FLANGE

Check that the sliding surface of disc is not worn or burnt. If the disc is worn burnt, replace all discs.

Then check that sliding surfaces of plate and flange are not worn or burnt.

If necessary replace them.

NOTE: Do not allow the discs to dry out. Prepare new discs by soaking them at least two hours in ATF.

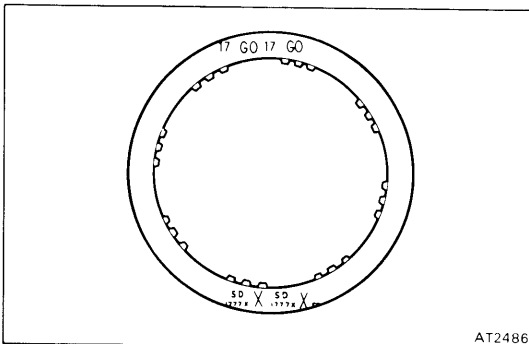

AT2486

ASSEMBLY OF REAR CLUTCH

(See page AT-59)

1. INSTALL NEW O-RINGS ON PISTONS

2. INSTALL REAR CLUTCH PISTONS IN DRUM

Press the rear clutch pistons into the drum with the cup side up, being careful not to damage the O-rings.

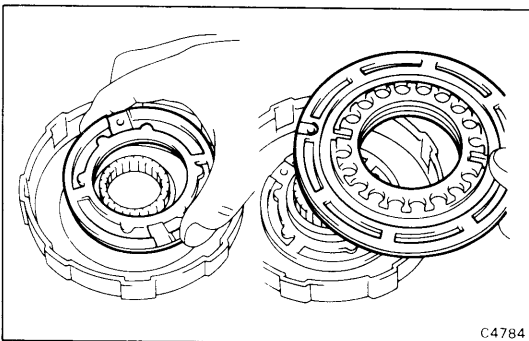

C4784

3. INSTALL EIGHTEEN PISTON RETURN SPRINGS AND SET RETAINER WITH SNAP RING IN PLACE

4. COMPRESS RETURN SPRINGS AND INSTALL SNAP RING IN GROOVE

- Place SST on the spring retainer, and compress the springs on a shop press.

SST 09350-20015 (09369-20040)

- Using a screwdriver, install the snap ring. Be sure the end gap of the snap ring is not aligned with the spring retainer claw.

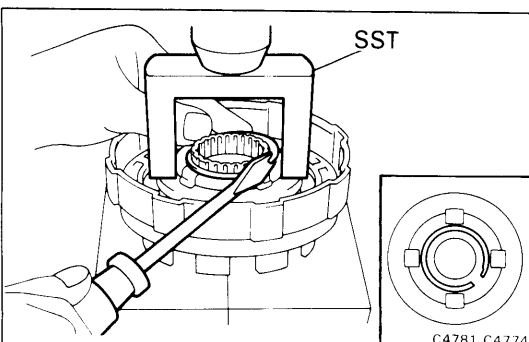

C4781 C4774

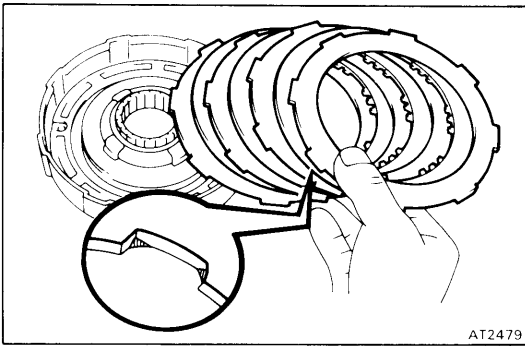

5. INSTALL DISCS, PLATES AND FLANGE

Using low-pressure compressed air, blow all excess ATF from the discs.

CAUTION: High-pressure air will damage the discs.

Install in order: Plate-disc-plate-disc-plate-disc-flange
(rounded edge down)

6. INSTALL SNAP RING

Check that the snap ring ends are not aligned with one of the cutouts.

7. CHECK PISTON STROKE OF REAR CLUTCH

Install the rear clutch onto the center support. Using a dial indicator as shown, measure the stroke applying and releasing the compressed air (4 – 8 kg/cm², 57 – 114 psi, or 392 – 785 kPa).

**Standard piston stroke: 1.06 – 2.14 mm
(0.0417 – 0.0843 in.)**

If the stroke exceeds the limit, the clutch pack is probably worn. If the stroke is less than the limit, parts may be misassembled or there may be excess ATF on the discs.

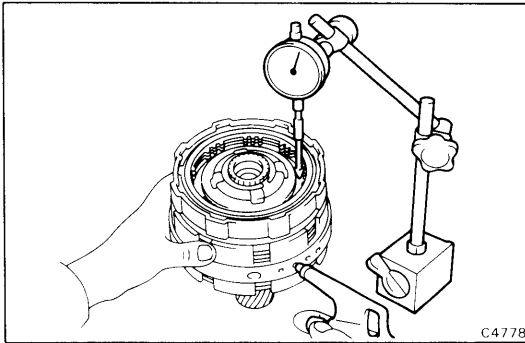

Center Support Assembly

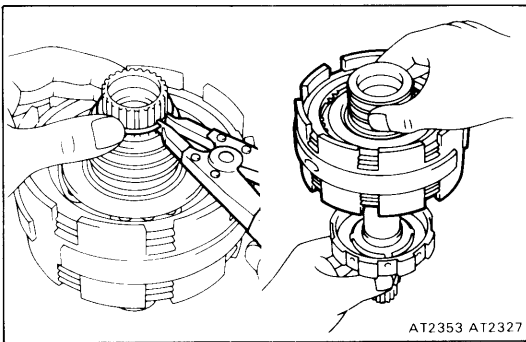
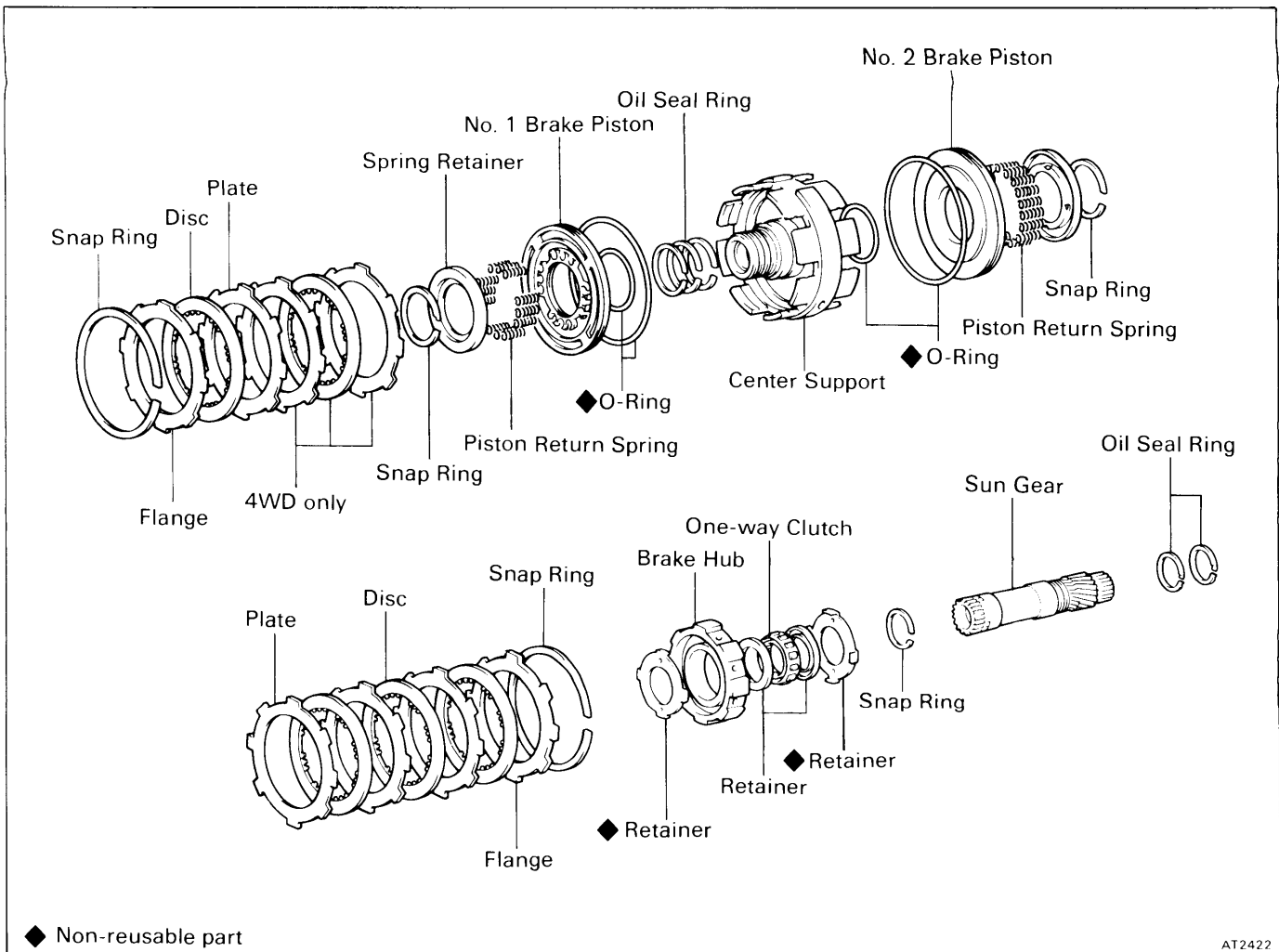

DISASSEMBLY OF CENTER SUPPORT ASSEMBLY

1. REMOVE SNAP RING FROM END OF SUN GEAR SHAFT
2. PULL CENTER SUPPORT ASSEMBLY FROM SUN GEAR
3. REMOVE SNAP RING FROM FRONT OF CENTER SUPPORT ASSEMBLY (NO. 1 BRAKE)
4. REMOVE CLUTCH FLANGE, DISC(S) AND PLATE(S) (NO. 1 BRAKE)

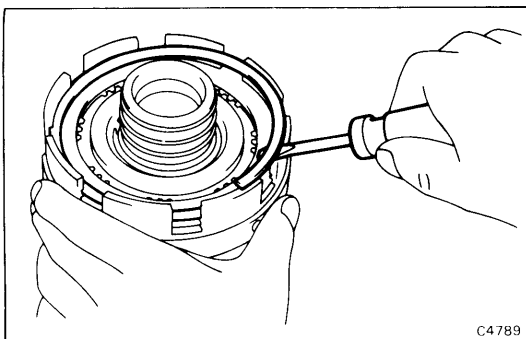

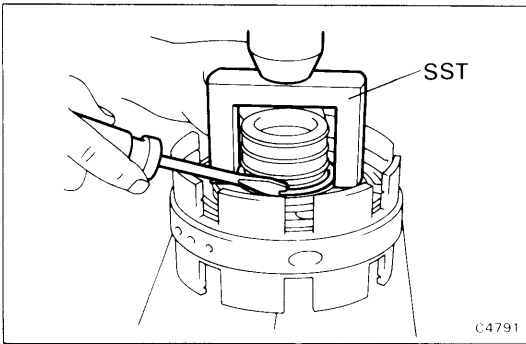

5. COMPRESS PISTON RETURN SPRINGS AND REMOVE SNAP RING

Place SST on the spring retainer and compress the springs with a shop press.

Using a screwdriver, remove snap ring.

SST 09350-20015 (09369-20040)

6. REMOVE SPRING RETAINER AND TWELVE SPRINGS

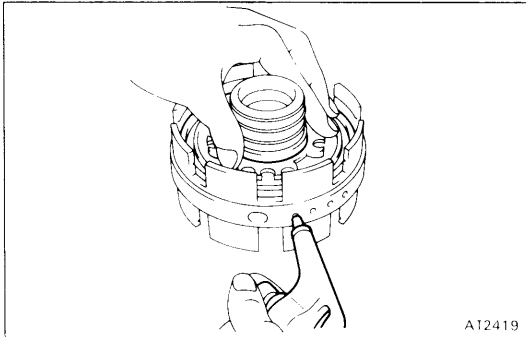

7. REMOVE NO. 1 BRAKE PISTON

Blow compressed air through the center support oil hole to remove the No. 1 brake piston.

If the piston does not pop out, lift it out with needle-nose pliers.

8. REMOVE NO. 1 BRAKE PISTON O-RINGS

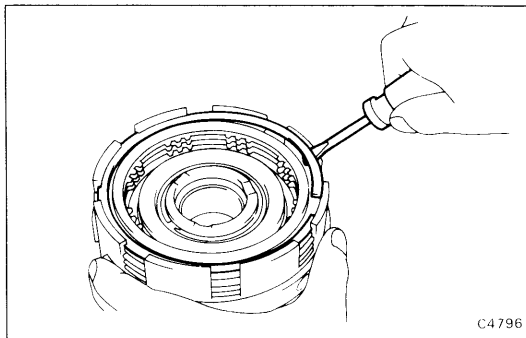

9. TURN CENTER SUPPORT ASSEMBLY OVER AND REMOVE REAR SNAP RING (NO. 2 BRAKE)

10. REMOVE CLUTCH FLANGE, DISCS AND PLATES (NO. 2 BRAKE)

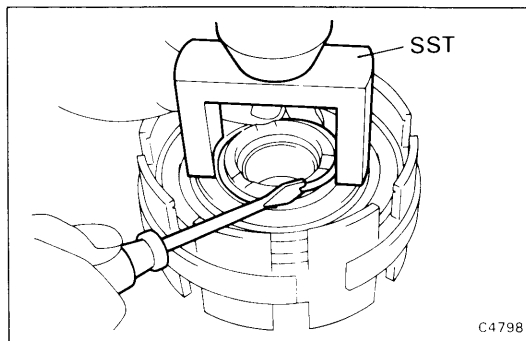

11. COMPRESS PISTON RETURN SPRINGS AND REMOVE SNAP RING

Place SST on the spring retainer and compress the springs with a shop press.

Using a screwdriver, remove snap ring.

SST 09350-20015 (09369-20040)

12. REMOVE SPRING RETAINER AND TWENTY SPRINGS

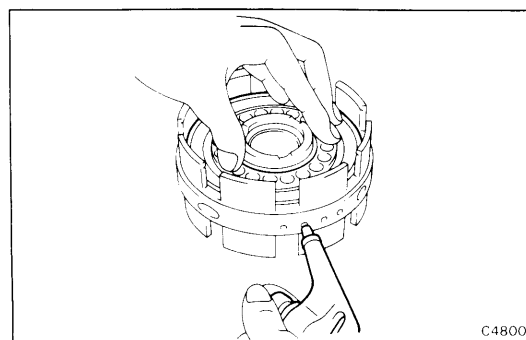

13. REMOVE NO. 2 BRAKE PISTON

Blow compressed air through the center support oil hole to remove the No. 2 brake piston.

If the piston does not pop out, lift it out with needle-nose pliers.

14. REMOVE NO. 2 BRAKE PISTON O-RINGS

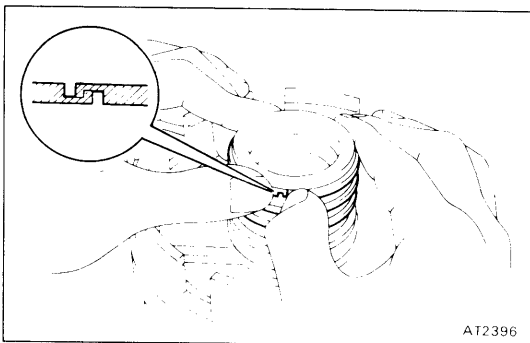

AT2396

15. REMOVE THREE OIL SEAL RINGS FROM CENTER SUPPORT

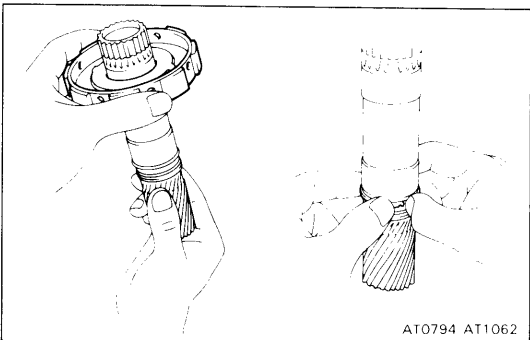

AT0794 AT1062

16. REMOVE ONE-WAY CLUTCH ASSEMBLY AND OIL SEAL RINGS FROM SUN GEAR

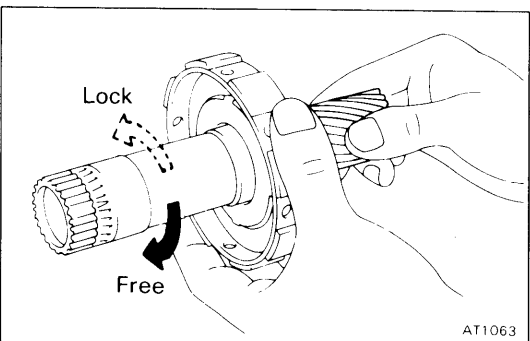

AT1063

INSPECTION OF CENTER SUPPORT ASSEMBLY

1. CHECK OPERATION OF ONE-WAY CLUTCH

Hold the No. 2 brake hub and turn the sun gear. The sun gear should turn freely counterclockwise and should lock clockwise.

If the one-way clutch does not work properly, replace it.

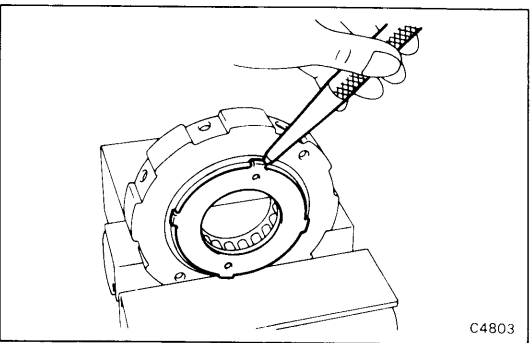

C4803

2. IF NECESSARY, REPLACE ONE-WAY CLUTCH

- Bend several tabs back with a tapered punch.
- Pry off the retainer with a screwdriver. Leave the other retainer on the hub.
- Remove the one-way clutch.

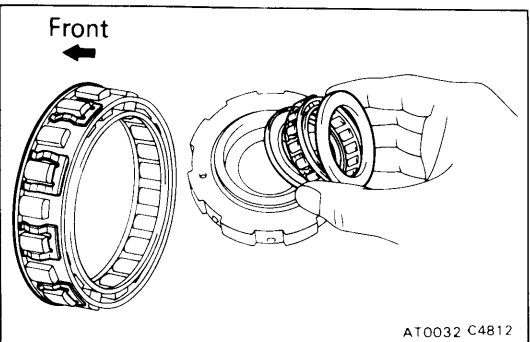

AT0032 C4812

- Install one-way clutch into the brake hub, facing the spring cage toward the front.

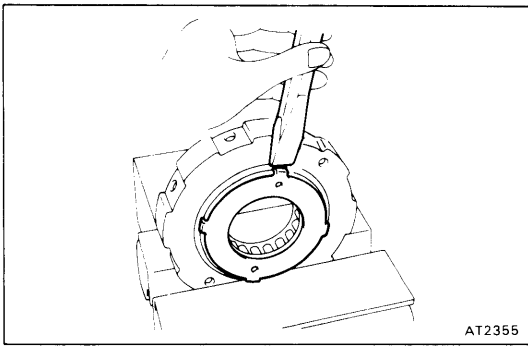

- (e) Hold the brake hub in a soft jawed vise, and flatten the ears with a chisel.
- (f) Check to make sure that the retainer is centered.

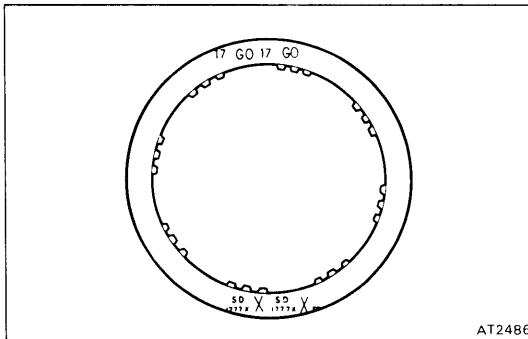

3. INSPECT DISC, PLATE AND FLANGE

Check that the sliding surface of disc is not worn or burnt. If the disc is worn or burnt, replace all discs.

Then check that the sliding surfaces of plate and flange are not worn or burnt.

If necessary, replace them.

NOTE: Do not allow the discs to dry out.

Prepare new discs by soaking them at least two hours in ATF.

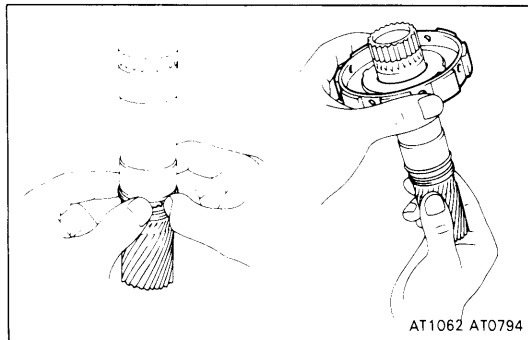

ASSEMBLY OF CENTER SUPPORT ASSEMBLY

(See page AT-62)

1. INSTALL TWO OIL SEAL RINGS AND ONE-WAY CLUTCH ASSEMBLY ON SUN GEAR

NOTE: After installing the oil seal rings, check that they move smoothly.

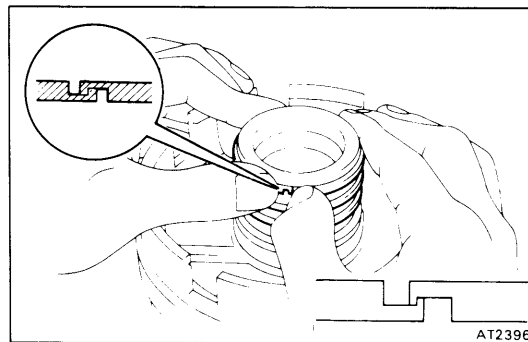

2. INSTALL THREE OIL SEAL RINGS ON CENTER SUPPORT

Spread apart and slip them into the groove. Hook both ends by hand.

NOTE: After installing the oil seal rings, check that they move smoothly.

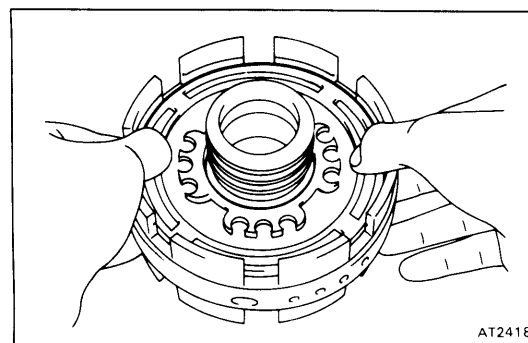

3. INSTALL NEW O-RINGS ON NO. 1 BRAKE PISTON

4. INSTALL NO. 1 BRAKE PISTON IN CENTER SUPPORT

Press No. 1 brake piston into the center support with the cup side up, being careful not to damage the O-rings.

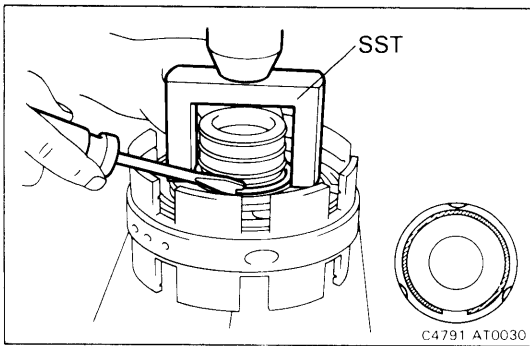

5. INSTALL TWELVE PISTON RETURN SPRINGS AND SET RETAINER WITH SNAP RING IN PLACE

6. COMPRESS RETURN SPRINGS AND INSTALL SNAP RING IN GROOVE

- (a) Place SST on the spring retainer, and compress the springs on shop press.

SST 09350-20015 (09369-20040)

- (b) Using a screwdriver, install the snap ring.
Be sure the end gap of the snap ring is not aligned with the spring retainer claw.

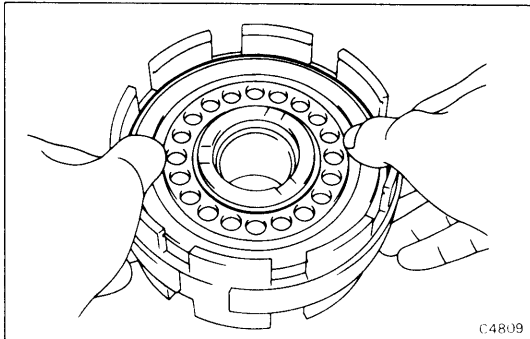

7. INSTALL NEW O-RINGS ON PISTON AND CENTER SUPPORT

8. TURN CENTER SUPPORT OVER AND INSTALL NO. 2 BRAKE PISTON

Press the No. 2 brake piston into the center support with the cup side up, being careful not to damage the O-rings.

9. INSTALL TWENTY PISTON RETURN SPRINGS AND SET RETAINER WITH SNAP RING IN PLACE

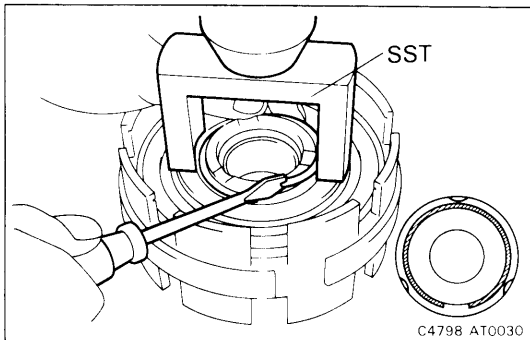

10. COMPRESS RETURN SPRINGS AND INSTALL SNAP RING IN GROOVE

- (a) Place SST on the spring retainer, and compress the springs on a shop press.

SST 09350-20015 (09369-20040)

- (b) Using a screwdriver, install the snap ring.
Be sure the end gap of the snap ring is not aligned with the spring retainer claw.

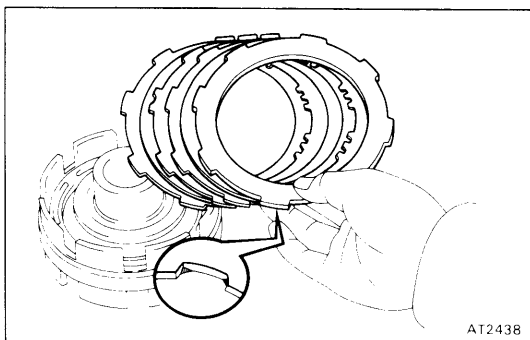

11. TURN CENTER SUPPORT OVER AND INSTALL NO. 1 BRAKE PISTON PLATE(S), DISC(S) AND FLANGE

Using low-pressure compressed air, blow all excess ATF from the discs.

CAUTION: High-pressure air will damage the disc(s).

Install in order:

2WD — Plate-disc-flange (rounded edge down)

4WD — Plate-disc-plate-plate-disc-flange (rounded edge down)

12. INSTALL SNAP RING IN CENTER SUPPORT

Check that the snap ring ends are not aligned with one of cutouts.

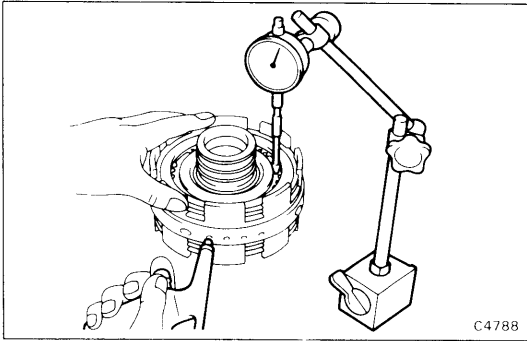

C4788

13. CHECK PISTON STROKE OF NO. 1 BRAKE

Using a dial indicator as shown, measure the stroke applying and releasing the compressed air (4 – 8 kg/cm², 57 – 114 psi, 392 – 785 kPa).

Standard piston stroke:

2WD 0.78 – 1.50 mm (0.0307 – 0.0591 in.)

4WD 0.80 – 1.73 mm (0.0315 – 0.0681 in.)

If the stroke exceeds the limit, the clutch pack is probably worn. If the stroke is less than the limit, parts may be misassembled or there may be excess ATF on the discs.

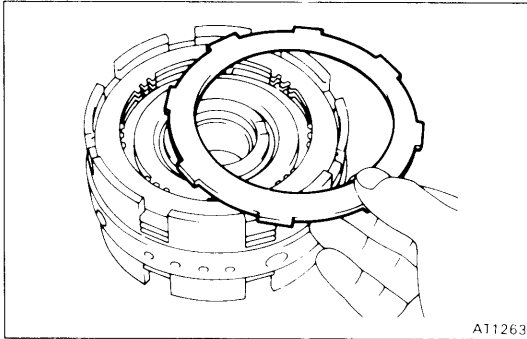

AT1263

14. TURN CENTER SUPPORT OVER AND INSTALL NO. 2 BRAKE PLATES, DISCS AND FLANGE

Using the low-pressure compressed air, blow all excess ATF from the discs.

CAUTION: High-pressure air will damage the discs.

Install in order: Plate-disc-plate-disc-plate-disc-flange (flat end down)

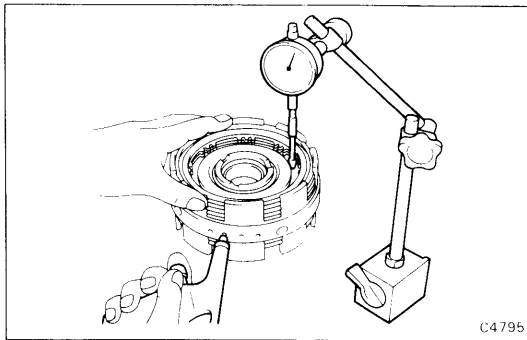

C4795

15. INSTALL SNAP RING IN CENTER SUPPORT

Check that the snap ring ends are not aligned with one of the cutouts.

16. CHECK PISTON STROKE OF NO. 2 BRAKE

Using a dial indicator as shown, measure the stroke applying and releasing the compressed air (4 – 8 kg/cm², 57 – 114 psi, or 392 – 785 kPa).

Standard piston stroke: 1.01 – 2.25 mm
(0.0398 – 0.0886 in.)

If the stroke exceeds the limit, the clutch pack is probably worn. If the stroke is less than the limit, parts may be misassembled or there may be excess ATF on the discs.

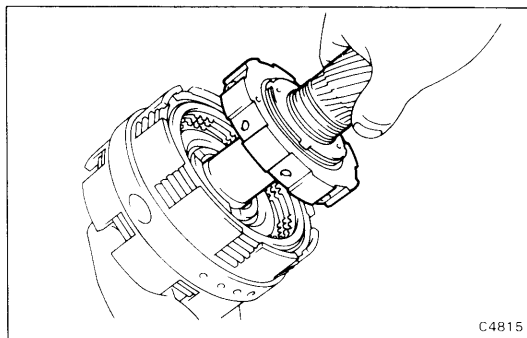

C4815

17. ASSEMBLE CENTER SUPPORT AND SUN GEAR

- Align the brake No. 2 disc flukes.
- Mesh the brake hub with the discs, twisting and jiggling the hub as required.

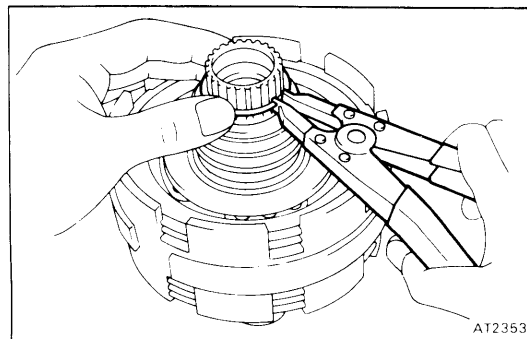

AT2353

18. INSTALL SNAP RING ON END OF SUN GEAR

Planetary Gear Output Shaft

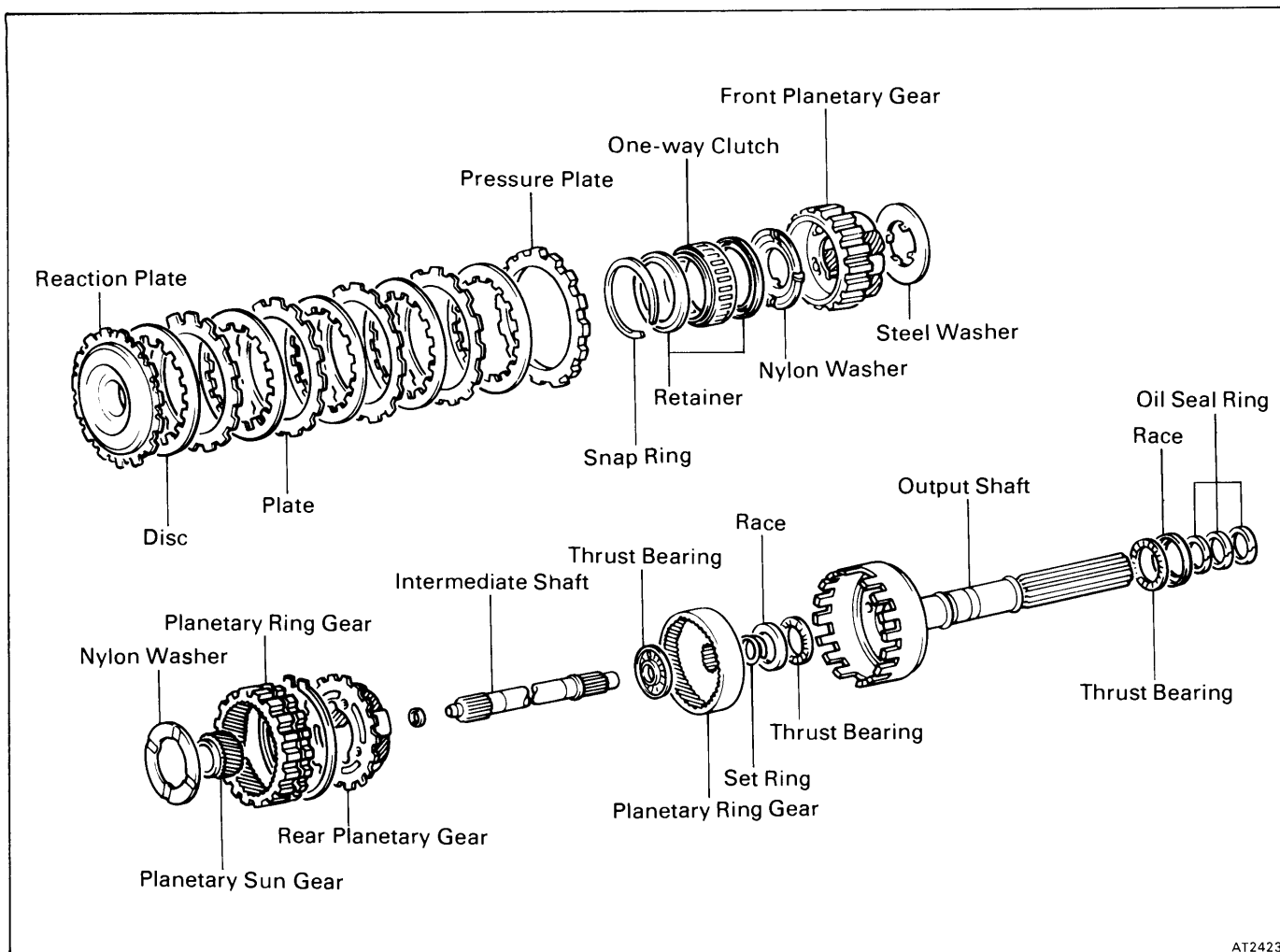

AT2423

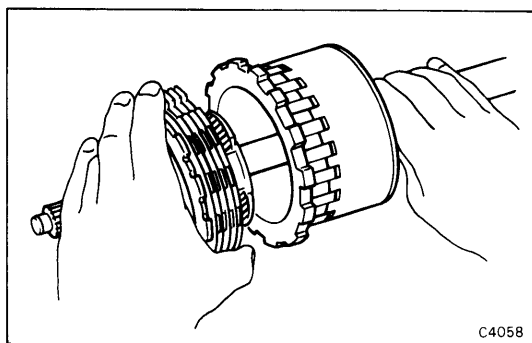

C4058

DISASSEMBLY OF PLANETARY GEAR OUTPUT SHAFT

1. REMOVE NO. 3 BRAKE DISC/PLATE PACK AND FRONT PLANETARY GEAR

Grasp the components and pull off the front end of the output shaft.

Be careful not to drop the bearing on the output shaft.

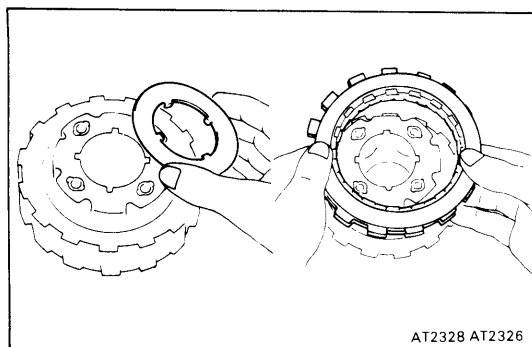

AT2328 AT2326

2. REMOVE THRUST WASHER FROM FRONT PLANETARY GEAR

NOTE: The thrust washer may stick to the inside of the planetary gear case.

3. REMOVE BRAKE DISCS AND PLATES FROM FRONT PLANETARY GEAR
4. REMOVE REACTION PLATE FROM FRONT PLANETARY GEAR

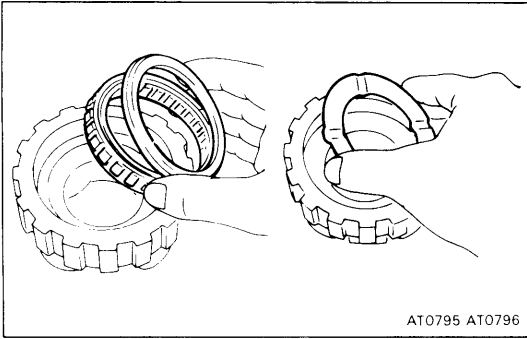

5. REMOVE SNAP RING AND ONE-WAY CLUTCH FROM FRONT PLANETARY GEAR

6. REMOVE THRUST WASHER FROM FRONT PLANETARY GEAR

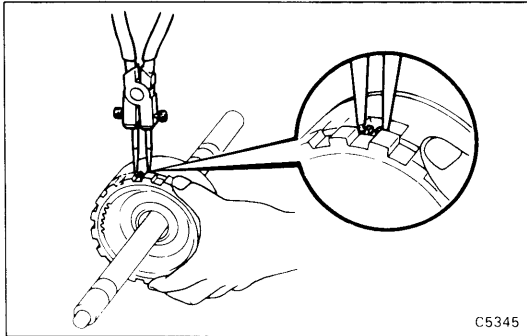

7. REMOVE APPLY TUBE AND CLUTCH PRESSURE PLATE

8. COMPRESS SHAFT SNAP RING AND REMOVE FRONT PLANETARY RING GEAR

(a) While pulling up the ring gear, compress the snap ring with needle-nose pliers and remove it from the groove.

(b) Pull out the ring gear by hand.

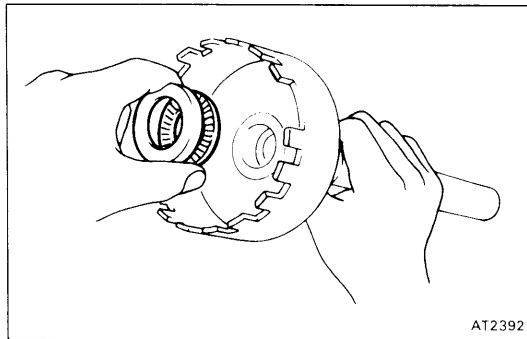

9. REMOVE INTERMEDIATE SHAFT FROM OUTPUT SHAFT ASSEMBLY

10. REMOVE THRUST BEARING AND RACE FROM OUTPUT SHAFT ASSEMBLY

Note the position of the race.

11. REMOVE THREE OIL SEAL RINGS FROM OUTPUT SHAFT

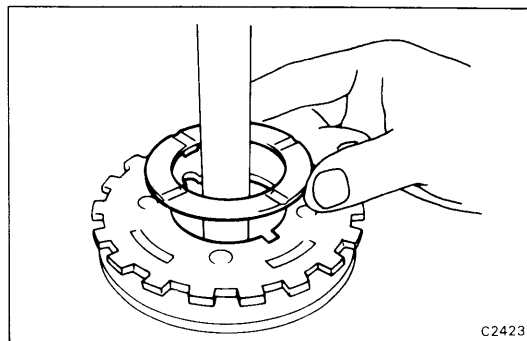

12. REMOVE NYLON WASHER FROM INTERMEDIATE SHAFT ASSEMBLY

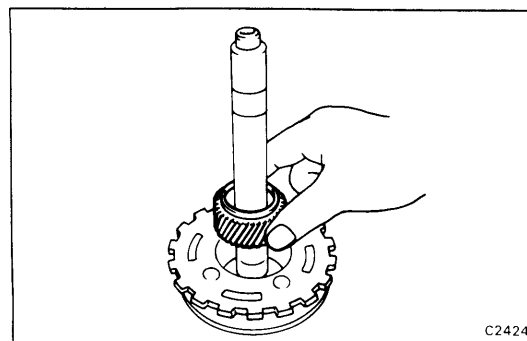

13. REMOVE PLANETARY SUN GEAR

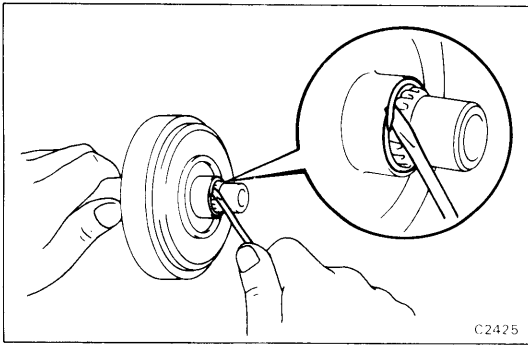

14. INVERT INTERMEDIATE SHAFT AND REMOVE SET RING

15. REMOVE REAR PLANETARY RING GEAR AND BEARING FROM INTERMEDIATE SHAFT

Note the direction of the bearing.

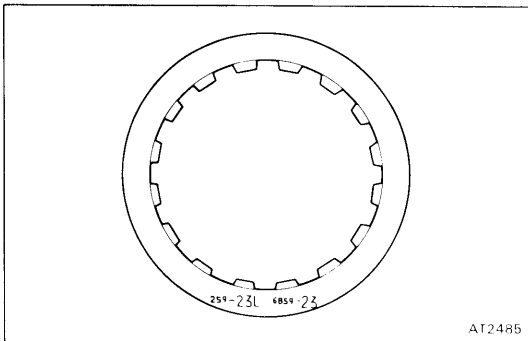

INSPECTION OF PLANETARY GEAR OUTPUT SHAFT

INSPECT DISC, PLATE AND FLANGE

Check that the sliding surface of disc is not worn or burnt. If the disc is worn or burnt, replace all discs.

Then check that the sliding surfaces of plate and flange are not worn or burnt.

If necessary, replace them.

NOTE: Do not allow the discs to dry out. Prepare new discs by soaking them at least two hours in ATF.

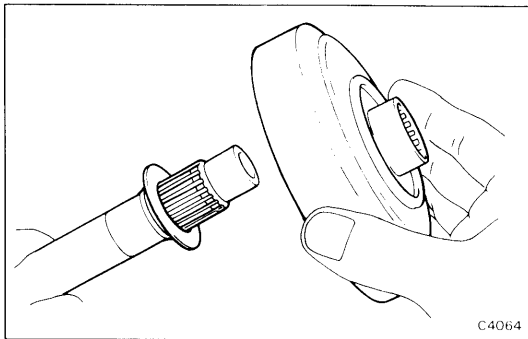

ASSEMBLY OF PLANETARY GEAR OUTPUT SHAFT

(See page AT-69)

1. INSTALL THRUST BEARING AND REAR PLANETARY RING GEAR ON INTERMEDIATE SHAFT

Slip the thrust bearing and ring gear onto the shaft with the exterior splines upward as shown.

2. INSTALL SET RING ON INTERMEDIATE SHAFT

Push down the set ring and wind it into the place. Check to make sure it is secure.

3. INSTALL REAR PLANETARY GEAR, NILON WASHER ON REAR PLANETARY RING GEAR

Install the washer with the lugs downward, fitting it into the rear planetary gear.

CAUTION: Make sure the different lug shapes match the openings on the plate.

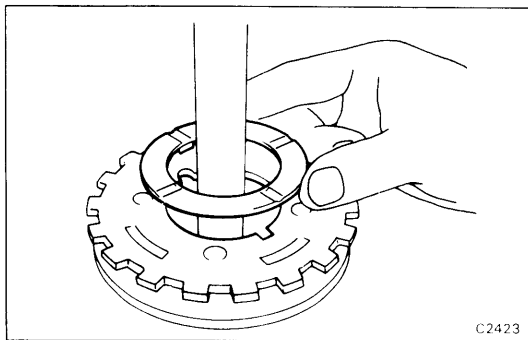

4. INSTALL THREE OIL SEAL RINGS ON OUTPUT SHAFT

Spread the rings apart and slide them into the groove. Hook both ends by hand.

NOTE: After installing the oil sealrings, check that they move smoothly.

5. INSTALL THRUST BEARING AND RACE ON OUTPUT SHAFT

Hold the cup of the race toward the bearing.

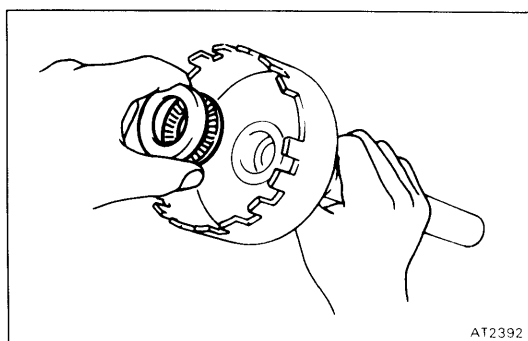

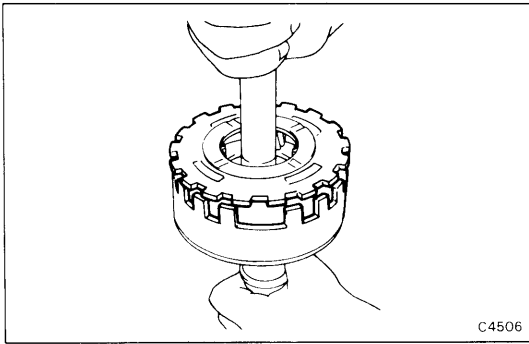

6. INSTALL REAR PLANETARY GEAR WITH INTERMEDIATE SHAFT ASSEMBLY IN OUTPUT SHAFT

Slide it into place, and make sure that the lugs interlock.

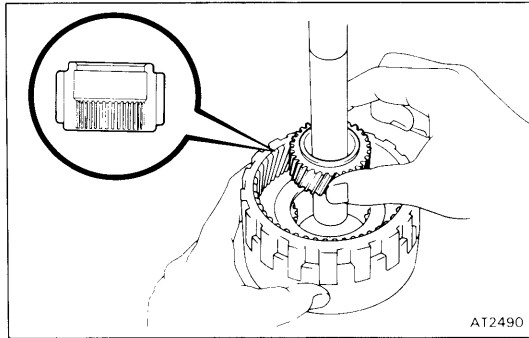

7. INSTALL PLANETARY SUN GEAR

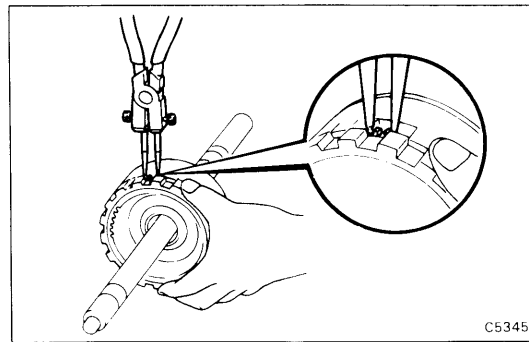

8. SET FRONT PLANETARY RING GEAR IN PLACE

Slide the snap ring downward, and align the lugs with the notches.

Align the ends of the snap ring with the wide gap between the teeth.

9. INSTALL FRONT PLANETARY RING GEAR WITH SNAP RING

While pushing down the ring gear, squeeze the snap ring end with needle-nose pliers and install it into the groove.

NOTE: When the snap ring is fully seated, the gap is the width of one lug.

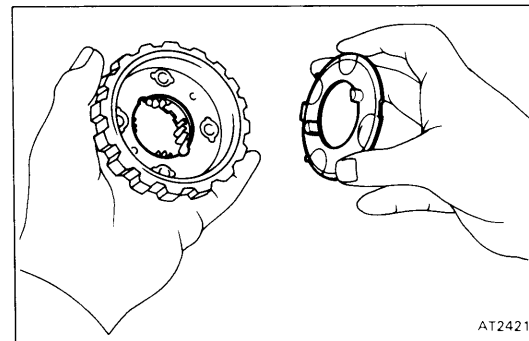

10. INSTALL NYLON WASHER IN FRONT PLANETARY GEAR

Face the lugs downward and match them with the slots in back of the planetary gear.

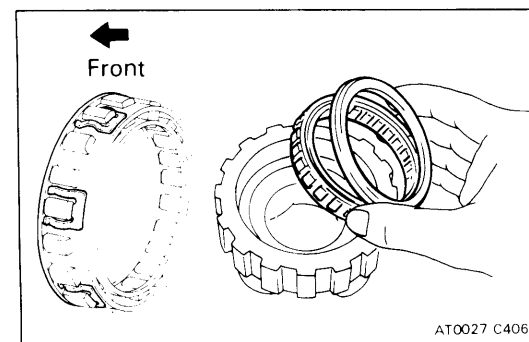

11. INSTALL ONE-WAY CLUTCH

Install the one-way clutch into the outer race, facing the spring cage toward the front.

12. INSTALL SNAP RING

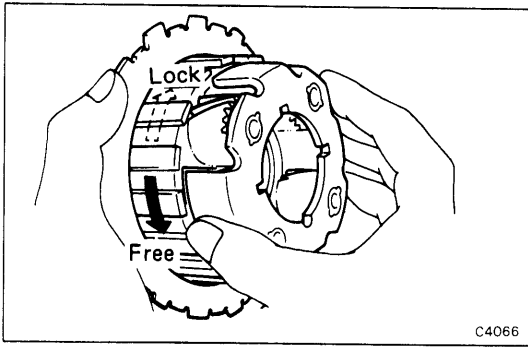

13. TEMPORARILY INSTALL REACTION PLATE ON FRONT PLANETARY GEAR

Insert it into place for test of the one-way clutch.

14. TEST ONE-WAY CLUTCH

The planetary gear must rotate freely counterclockwise and lock clockwise.

If the clutch does not work correctly, it must be replaced.

15. REMOVE REACTION PLATE

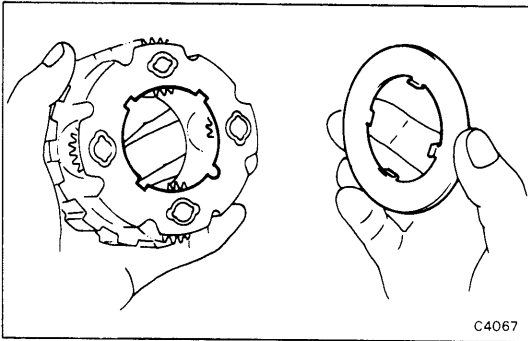

16. INSTALL THRUST WASHER ON FRONT PLANETARY GEAR

Apply petroleum jelly to washer to hold it in place during later assembly. Match the lugs with the planetary gear while installing.

17. INSTALL FRONT PLANETARY GEAR ASSEMBLY TO INTERMEDIATE SHAFT

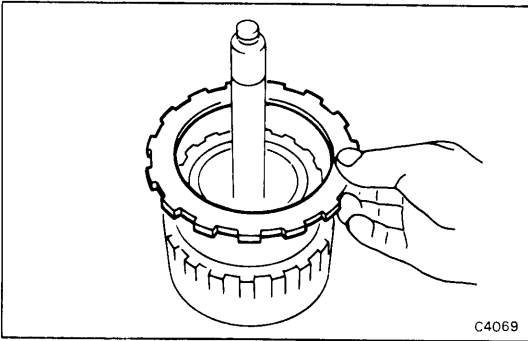

18. INSTALL PRESSURE PLATE

Install the pressure plate, facing the flat surface toward the intermediate shaft.

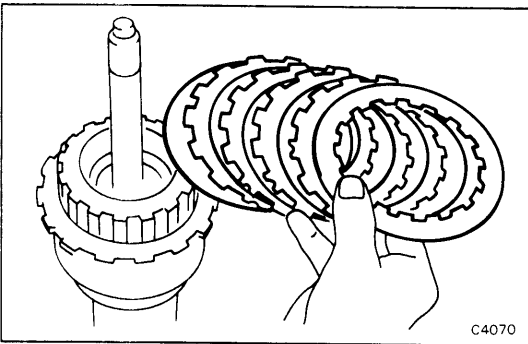

19. INSTALL NO. 3 BRAKE CLUTCH PACK

Using low-pressure compressed air, blow all excess ATF from the discs.

CAUTION: High-pressure air will damage the discs.

Install in order: Disc-plate-disc-plate-disc-plate-disc-plate-disc

20. KEEP REACTION PLATE, APPLY TUBE, THRUST BEARING AND RACE TOGETHER

Transmission Case and Rear Brake Pistons

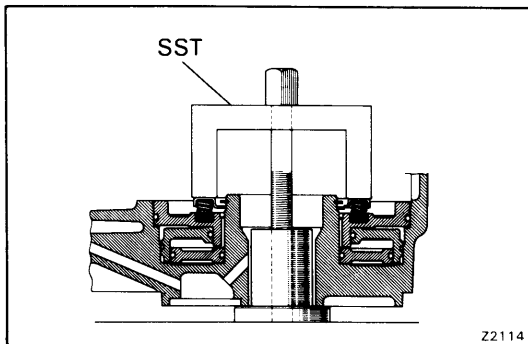
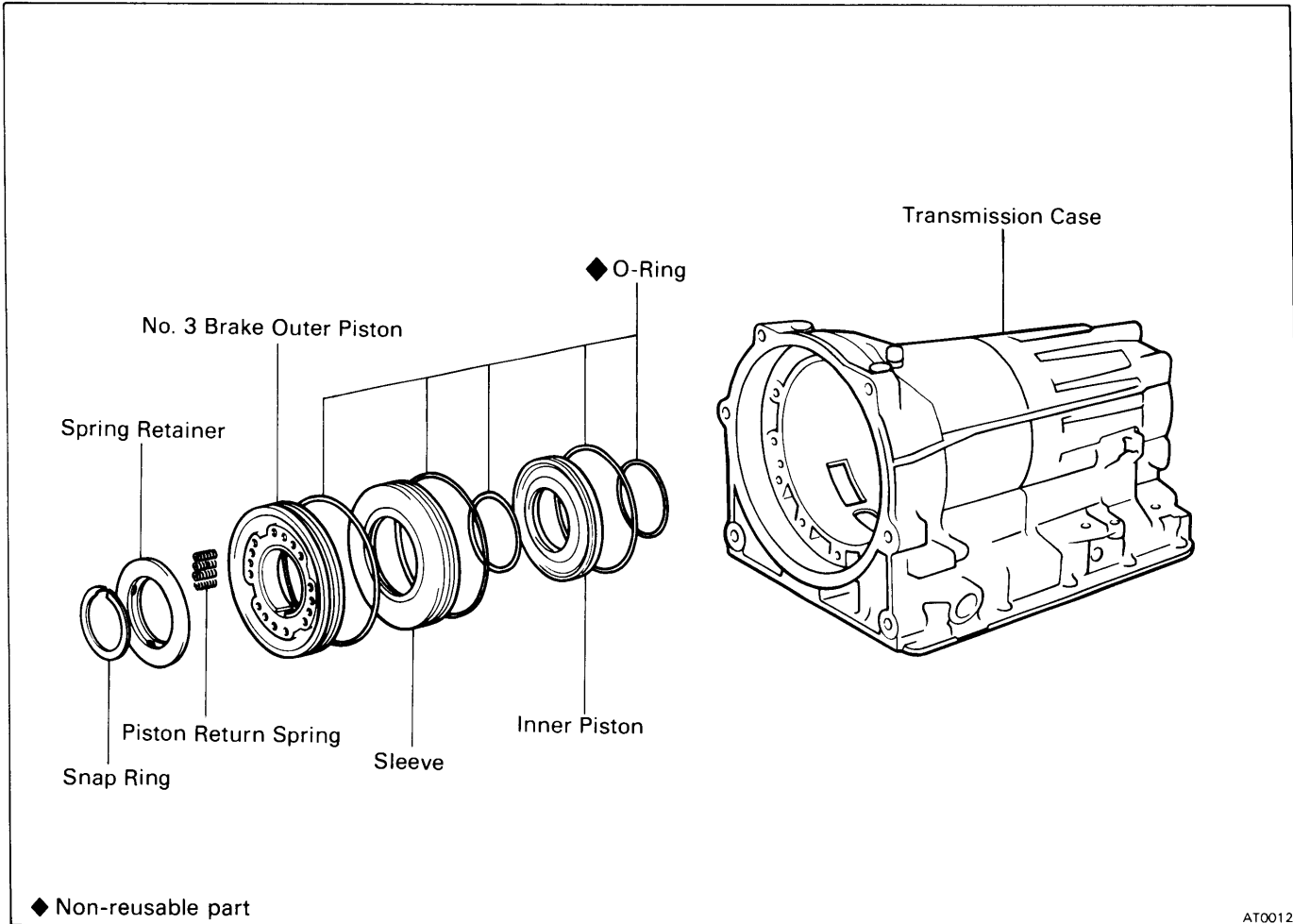

DISASSEMBLY OF TRANSMISSION CASE AND REAR BRAKE PISTONS

1. COMPRESS RETURN SPRINGS AND REMOVE SPRING RETAINER SNAP RING

- Install the SST. Gradually and evenly tighten the bolt to compress the springs, being careful not to damage the transmission case with SST.

SST 09350-20015 (09369-20040)

- Using the screwdriver and a hook, remove the snap ring.

2. REMOVE SPRING RETAINER AND SIXTEEN SPRINGS

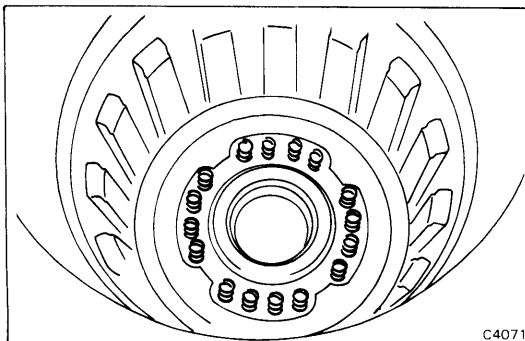

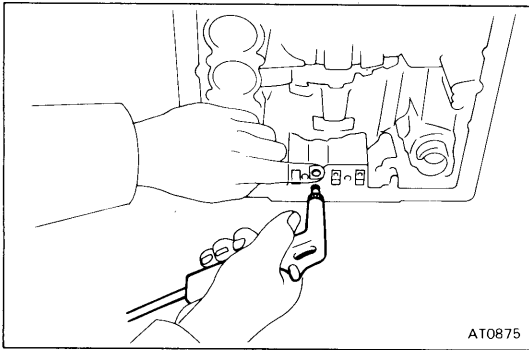

AT0875

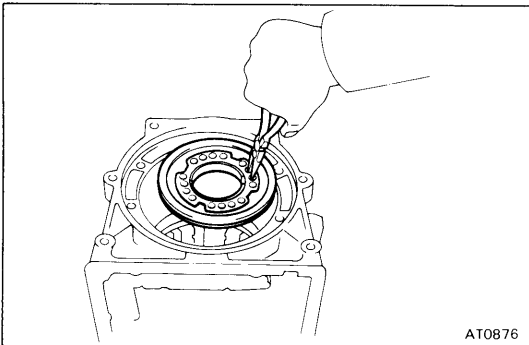

AT0876

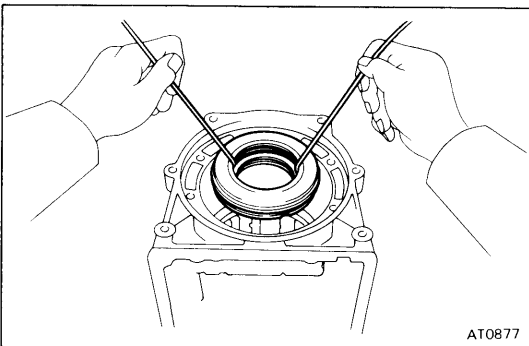

AT0877

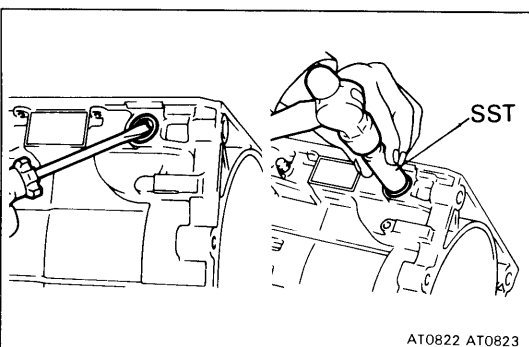

AT0822 AT0823

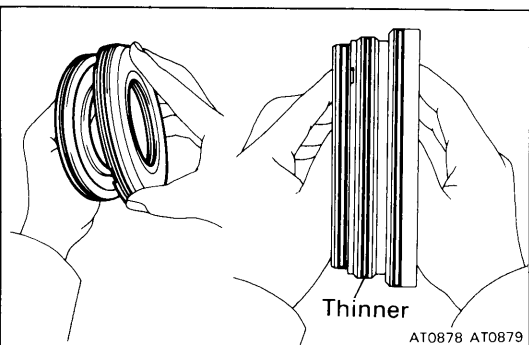

AT0878 AT0879

3. REMOVE OUTER PISTON AND REACTION SLEEVE WITH COMPRESSED AIR

- (a) Turn the case over face down on a workbench. Place several clean shop rags under the case to catch the piston and sleeve. To pop them out, apply compressed air to the outer and inner piston oil holes.

If the piston and sleeve do not pop out with compressed air:

- (b) Using needle-nose pliers, lift the outer piston from the case.

- (c) Insert two long hooks behind the reaction sleeve and slowly lift it out of the case.

- (d) Using hooks, lift the inner piston out of the case in the same manner.

4. REMOVE O-RINGS FROM OUTER AND INNER PISTONS AND REACTION SLEEVE

INSPECTION OF CASE COMPONENT GROUP

REPLACEMENT OF MANUAL SHAFT OIL SEALS

- (a) Remove the manual shaft oil seals with a screwdriver.
- (b) Drive in new left and right oil seals with SST.
SST 09350-20015 (09361-30011)

ASSEMBLY OF TRANSMISSION CASE AND REAR BRAKE PISTONS

(See page AT-73)

1. INSTALL NEW O-RINGS ON REACTION SLEEVE AND PISTONS

CAUTION: The thinner O-ring goes on the outside of the reaction sleeve.

2. INSTALL INNER AND OUTER PISTONS IN REACTION SLEEVE

- (a) Push the inner piston into the cupped side of the reaction sleeve.
- (b) Push the outer piston onto the other side of the reaction sleeve.

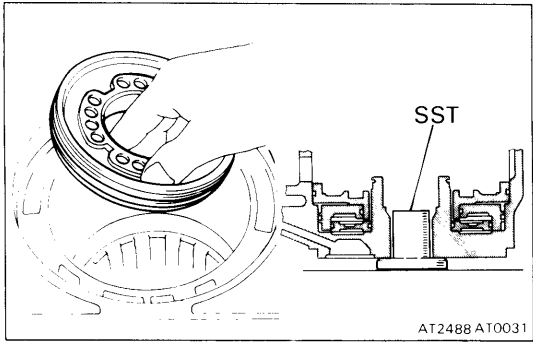

3. INSTALL PISTONS AND SLEEVE IN CASE

CAUTION: Be careful not to damage the O-rings.

Hold the assembly with the outer piston up (spring seats visible), and push the assembly into its bore in the case.

4. INSTALL SST BASE UNDER CASE

SST 09350-20015 (09369-20040)

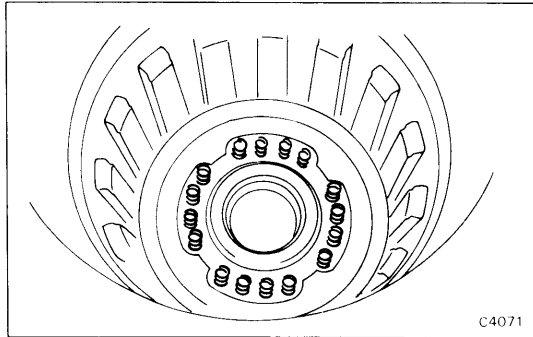

5. INSTALL SIXTEEN PISTON RETURN SPRINGS AND SET RETAINER WITH SNAP RING IN PLACE

NOTE: Springs are visible through cutout in the case, which helps to position them more easily.

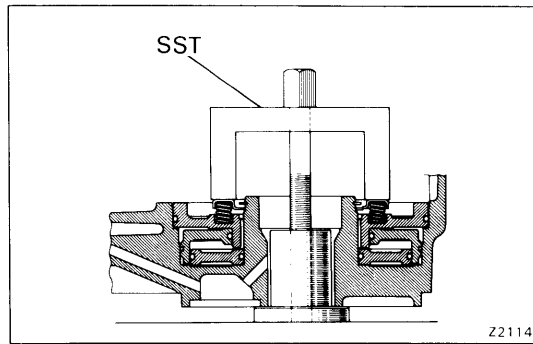

6. COMPRESS PISTON RETURN SPRINGS TO ALLOW INSTALLATION OF SNAP RING

CAUTION: Avoid bending the spring retainer by overtightening the bolts.

- (a) Carefully position the spring compressor on the spring retainer.
- (b) Gradually and evenly tighten the bolt to compress the springs, being careful not to damage the transmission case with SST.

SST 09350-20015 (09369-20040)

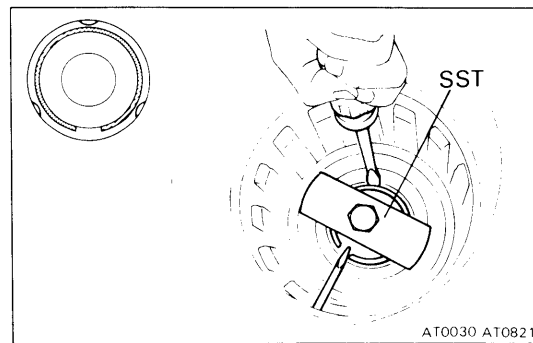

7. INSTALL SNAP RING

- (a) Push it into place by hand. Visually check to make sure it is fully seated and centered by the three lugs on the spring retainer.
- (b) Remove the SST.

SST 09350-20015 (09369-20040)

Valve Body

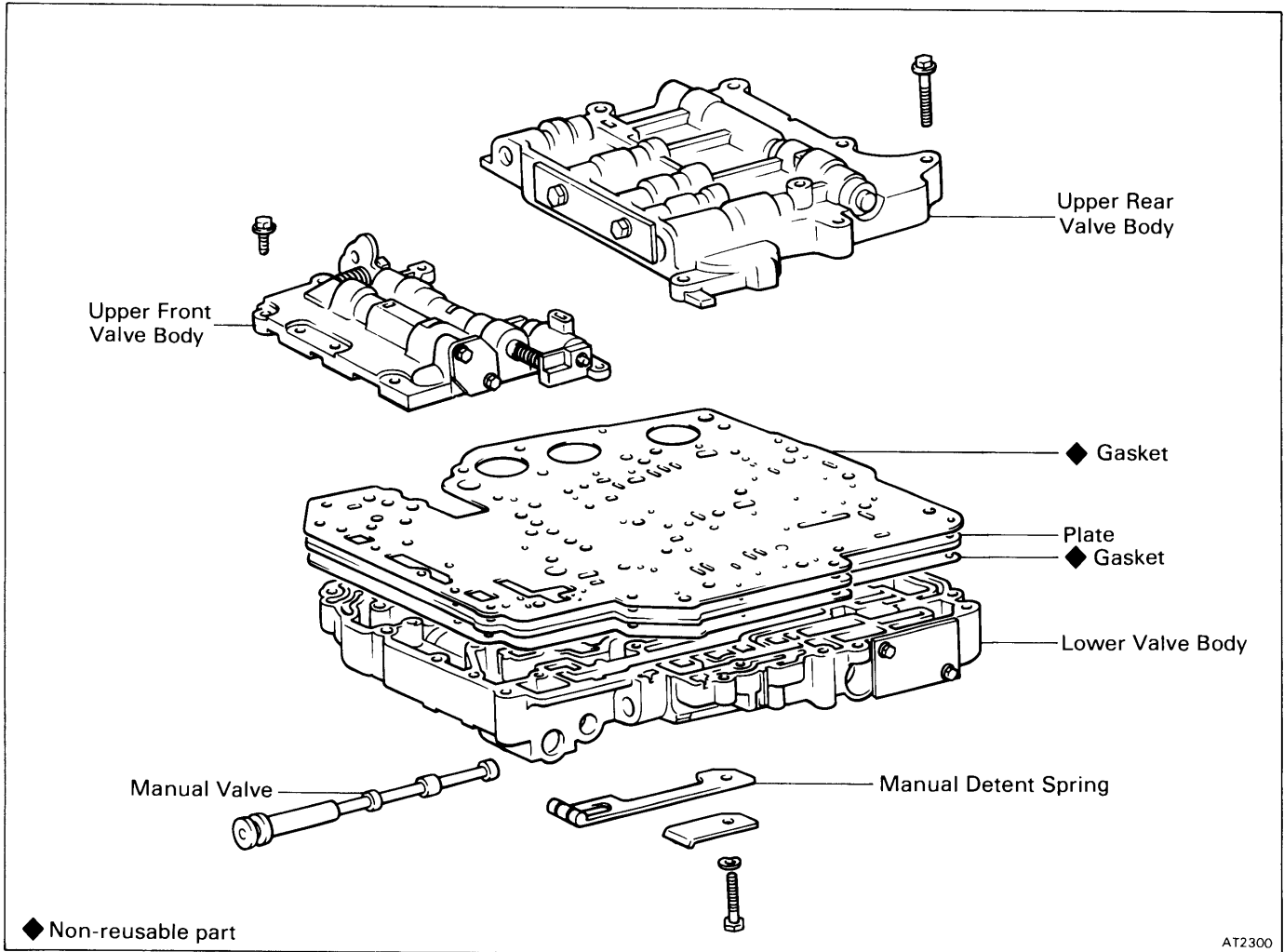

cardiagn.com

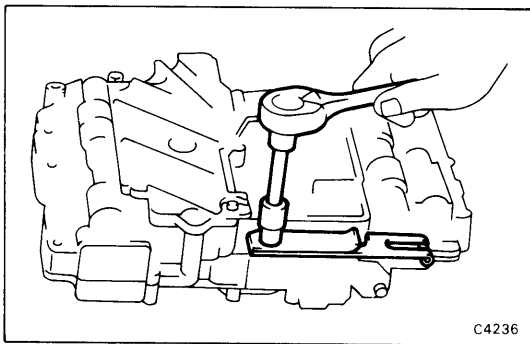

(Disassembly of Valve Body)

1. REMOVE DETENT SPRING
2. REMOVE MANUAL VALVE

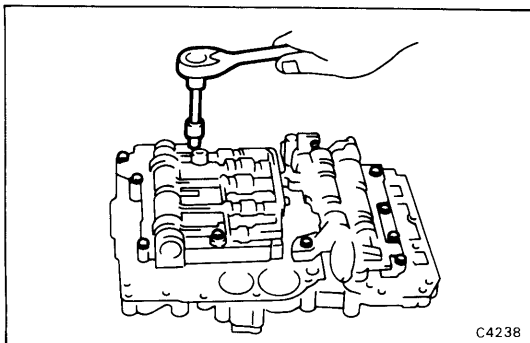

3. TURN ASSEMBLY OVER AND REMOVE TEN BOLTS FROM UPPER FRONT VALVE BODY AND UPPER REAR VALVE BODY

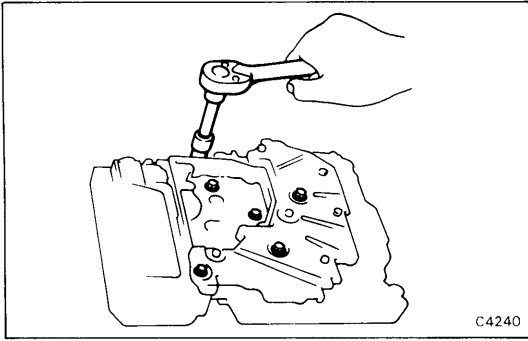

4. **TURN ASSEMBLY OVER AND REMOVE SET BOLTS FROM LOWER VALVE BODY**

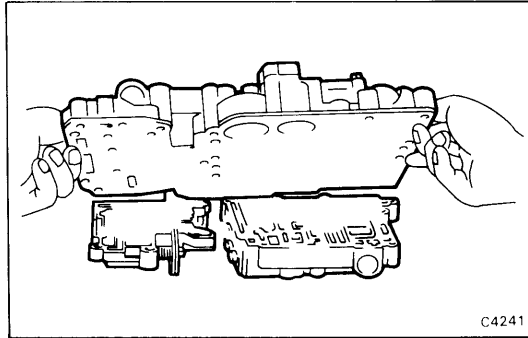

5. **LIFT OFF LOWER VALVE BODY AND PLATE AS SINGLE UNIT**

NOTE: Be careful that none of the valves or balls fall out.

(Lower Valve Body)

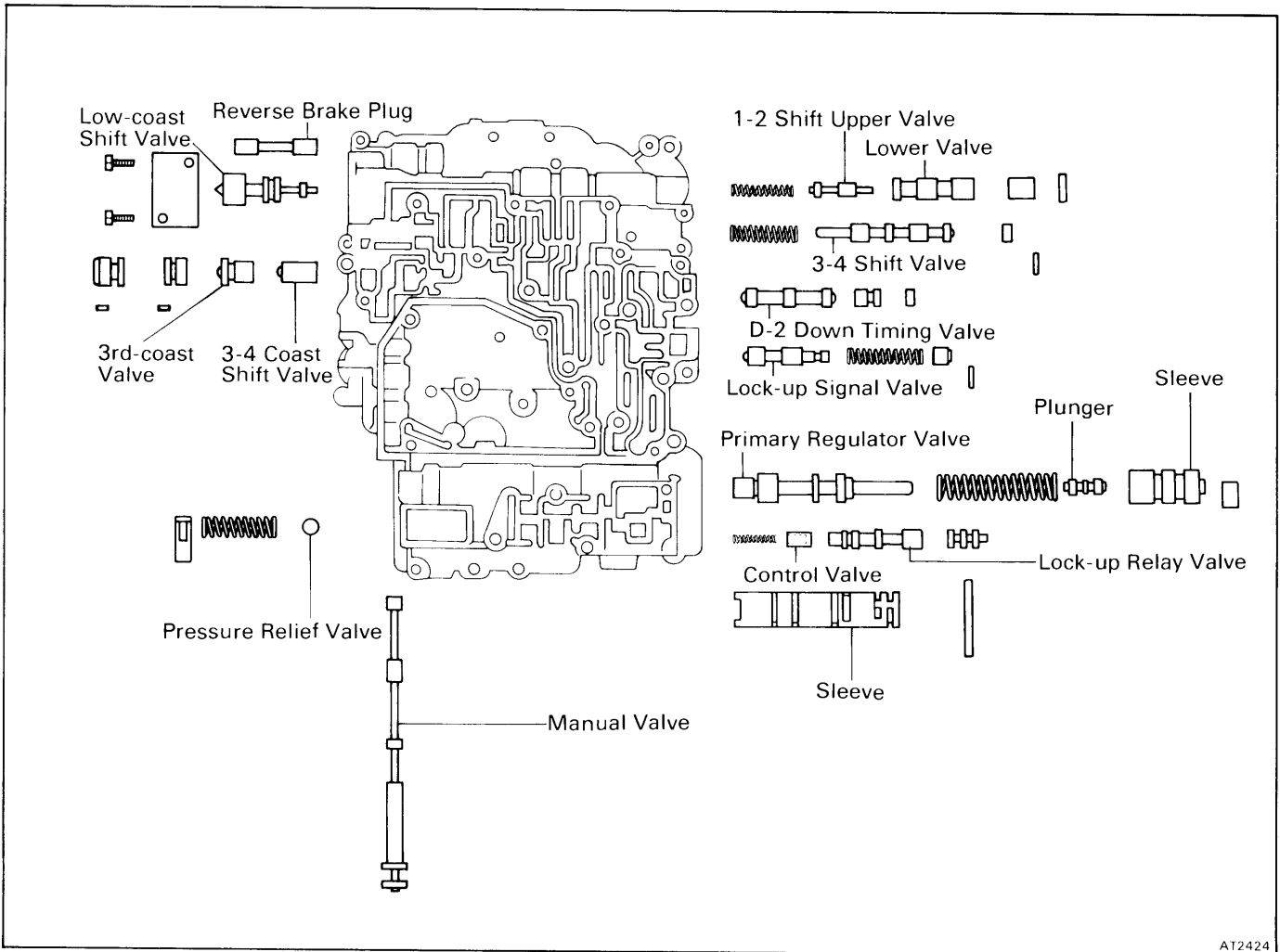

AT2424

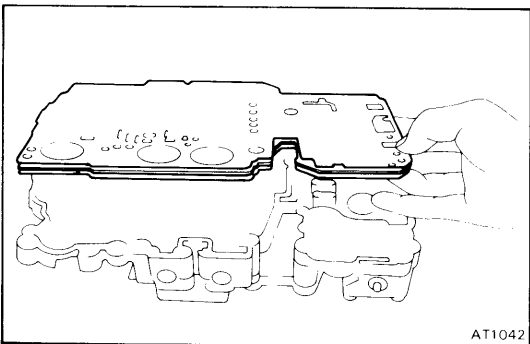

AT1042

DISASSEMBLY OF LOWER VALVE BODY

- 1. REMOVE LOWER VALVE BODY PLATE AND GASKETS**

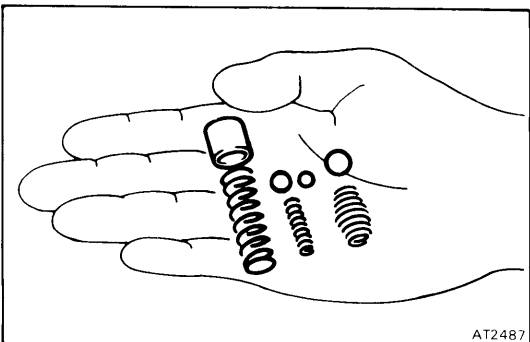

AT2487

- 2. REMOVE DAMPING CHECK BALL, COOLER RETURN CHECK BALL, COOLER BY-PASS VALVE AND SPRINGS**

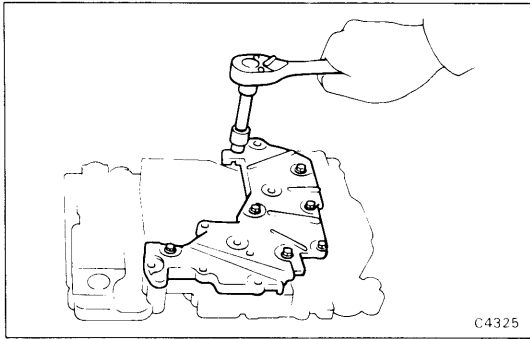

3. **TURN ASSEMBLY OVER, REMOVE SET BOLT AND REMOVE LOWER BODY COVER, PLATE AND GASKETS**

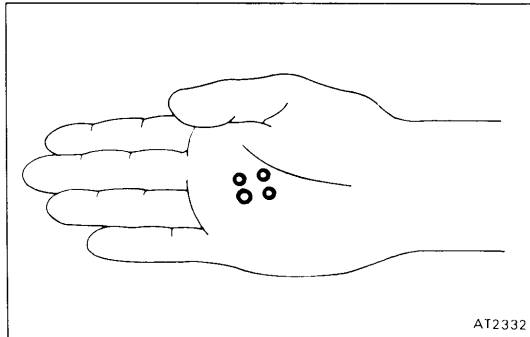

4. **REMOVE CHECK BALLS**

Remove check balls, being careful not to scratch the grooves. Keep the balls together to prevent losing them.

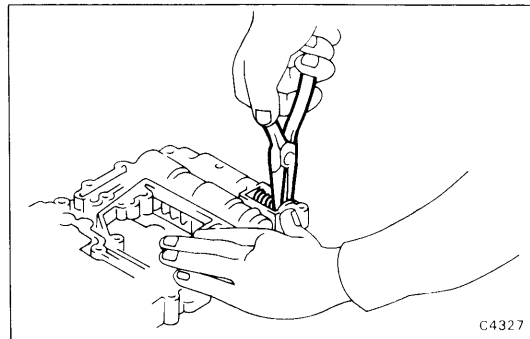

5. **REMOVE SPRING RETAINER FROM PRESSURE RELIEF ASSEMBLY**

CAUTION: Cover the spring four hand. Then, using needle-nose pliers, slowly pull out the spring seat, being careful not to bend the spring.

6. **REMOVE PRESSURE RELIEF SPRING AND BALL**

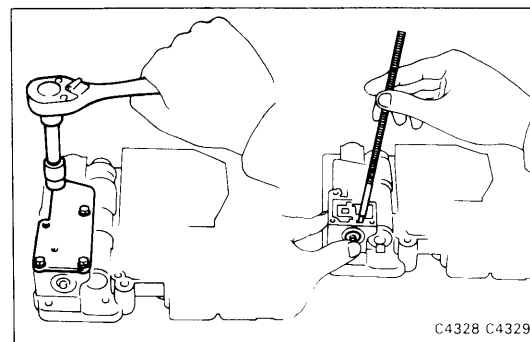

7. **REMOVE PLATE AND GASKET**

8. **REMOVE LOCK-UP RELAY VALVE**

(a) Remove plug retainer and plug.

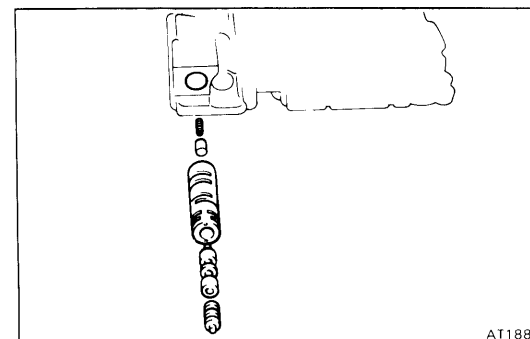

(b) Remove sleeve with lock-up relay valve, control valve and spring.

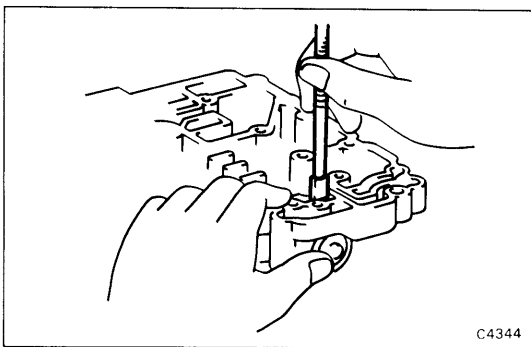

9. REMOVE SPRING RETAINER FROM PRIMARY REGULATOR VALVE

WARNING: Highly compressed spring inside — keep away from face.

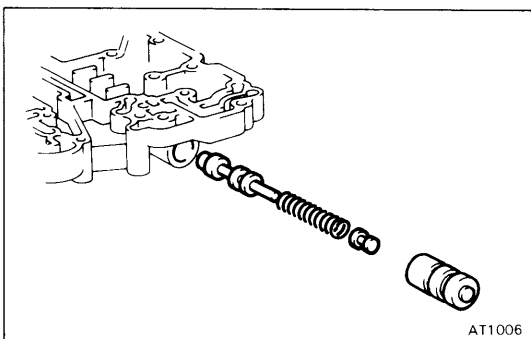

10. REMOVE SLEEVE, PLUNGER, SPRING AND PRIMARY REGULATOR VALVE

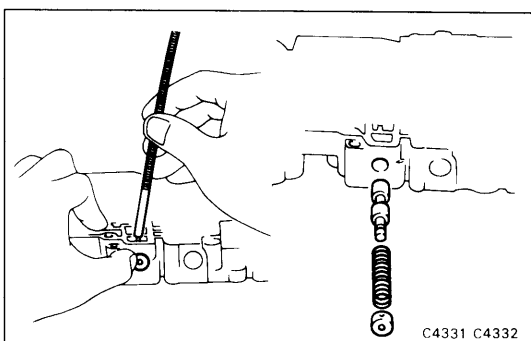

11. REMOVE LOCATING PIN FOR LOCK-UP SIGNAL VALVE

12. REMOVE PLUG, SPRING AND LOCK-UP SIGNAL VALVE

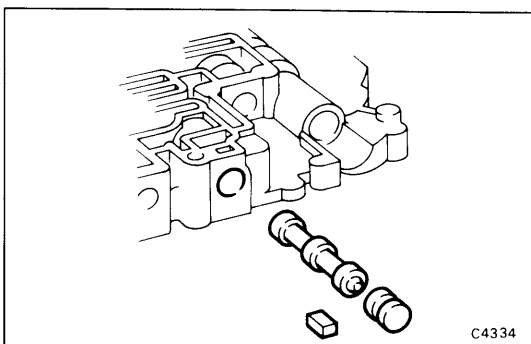

13. REMOVE PLUG RETAINER FOR D-2 DOWN TIMING VALVE

14. REMOVE PLUG AND D-2 DOWN TIMING VALVE

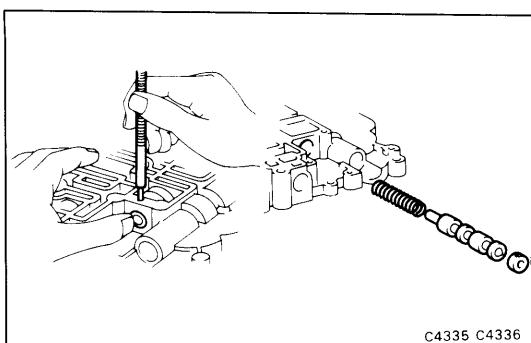

15. REMOVE PLUG LOCATING PIN FOR 3-4 SHIFT VALVE

16. REMOVE PLUG, 3-4 SHIFT VALVE AND SPRING

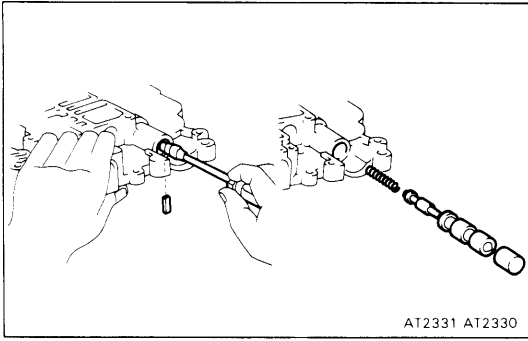

AT2331 AT2330

- 17. REMOVE PLUG RETAINER FOR 1-2 SHIFT VALVE
- 18. REMOVE PLUG, 1-2 SHIFT VALVE AND SPRING
- 19. REMOVE COVER PLATE

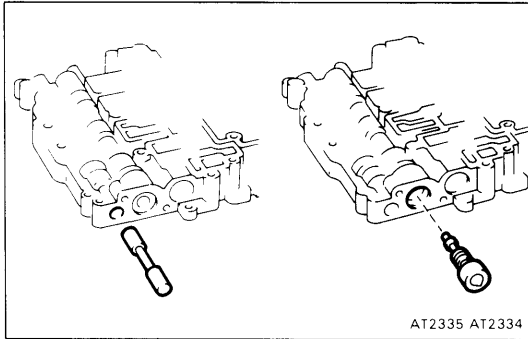

AT2335 AT2334

- 20. REMOVE REVERSE BRAKE SEQUENCE PLUG
- 21. REMOVE LOW-COAST SHIFT VALVE

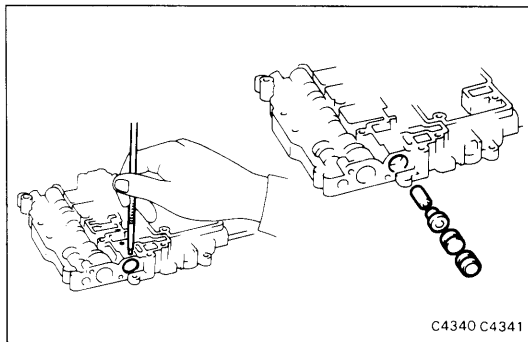

C4340 C4341

- 22. REMOVE LOCATING PINS FOR THIRD-COAST VALVE
- 23. REMOVE PLUGS, THIRD-COAST VALVE AND 3-4 CONTROL VALVE

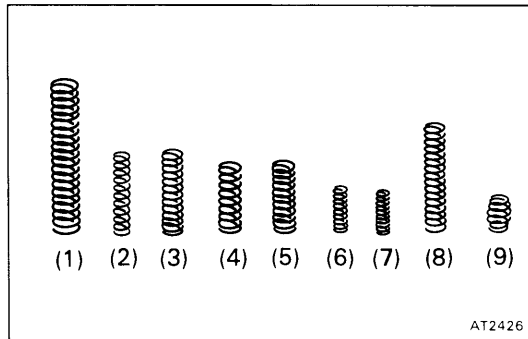

AT2426

INSPECTION OF LOWER VALVE BODY

INSPECT VALVE SPRINGS

Check for damage, squareness, rust and distorted coils. Measure the spring free height and replace it if less than that shown below.

	Free length mm (in.)	Color
(1) Primary regulator valve	61.20 (2.4094)	White
(2) 1-2 shift valve	34.62 (1.3630)	None
(3) 3-4 shift valve	36.28 (1.4283)	Red
(4) Oil cooler by-pass valve	28.90 (1.1378)	Orange
(5) Pressure relief valve	32.14 (1.2654)	None
(6) Damping check ball	20.00 (0.7874)	None
(7) Lock-up relay valve	18.50 (0.7283)	White
(8) Lock-up signal valve	38.60 (1.5197)	Light Blue
(9) Cooler return ball	13.70 (0.5394)	None

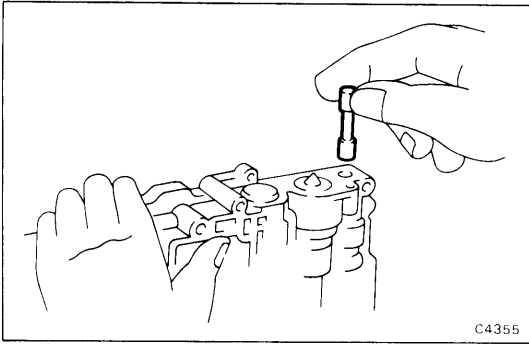

ASSEMBLY OF LOWER VALVE BODY

(See page AT-78)

1. INSTALL REVERSE BRAKE SEQUENCE PLUG

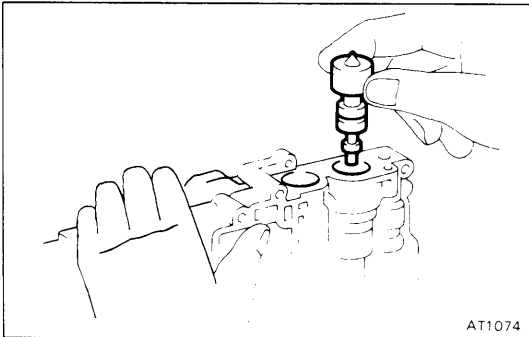

2. INSTALL LOW-COAST SHIFT VALVE

Carefully insert the low-coast shift valve with the small end first.

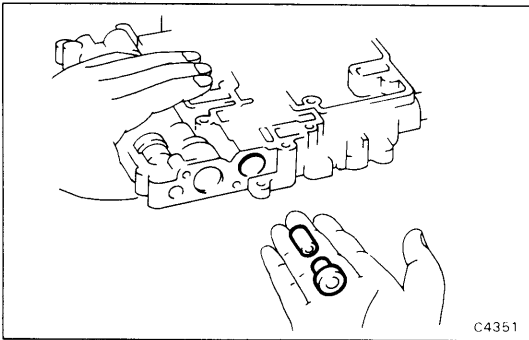

3. INSTALL 3-4 COAST SHIFT VALVE AND THIRD-COAST VALVE

- Insert the 3-4 coast shift valve with the cup side first.
- Insert the 3rd-coast valve with the small end first.

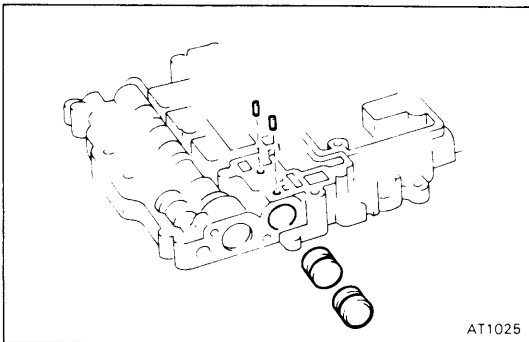

4. INSTALL TWO PLUGS AND LOCATING PIN

- Insert the inside plug with the thick face first.
- Using needle-nose pliers, insert the locating pin.
- Insert the outside plug, and then insert the locating pin.

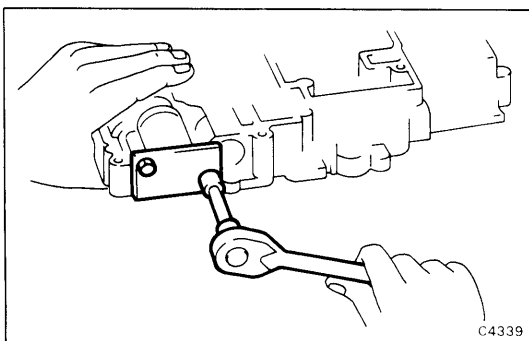

5. INSTALL COVER PLATE

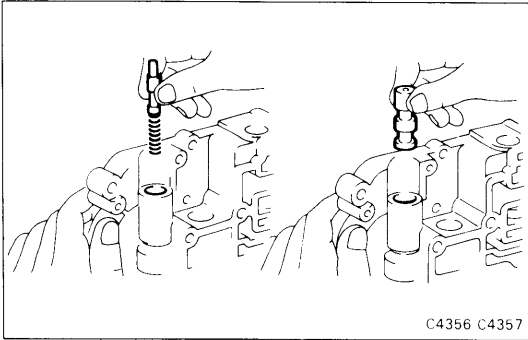

6. INSERT SPRING, 1-2 SHIFT UPPER VALVE, LOWER VALVE AND PLUG

Set the valve body on edge and carefully insert the spring, 1-2 shift upper valve, lower valve and plug.

7. INSTALL 1-2 SHIFT VALVE PLUG RETAINER

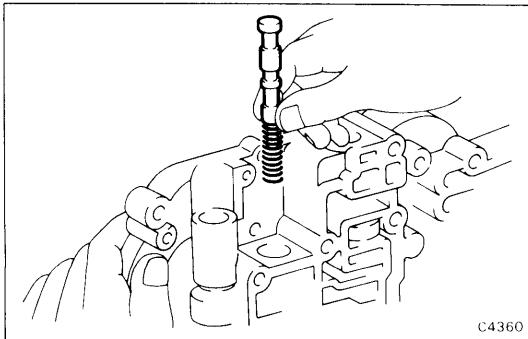

8. INSERT SPRING, 3-4 SHIFT VALVE AND PLUG

Set the valve body on edge and carefully insert the spring, 3-4 shift valve (small end first) and plug.

9. INSTALL 3-4 SHIFT VALVE PLUG LOCATING PIN

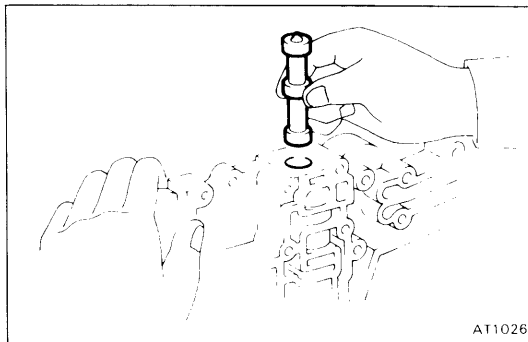

10. INSTALL D-2 DOWN TIMING VALVE AND PLUG

Insert the D-2 down timing valve with the small end first and then the plug with the large end first.

11. INSTALL D-2 DOWN TIMING VALVE RETAINER

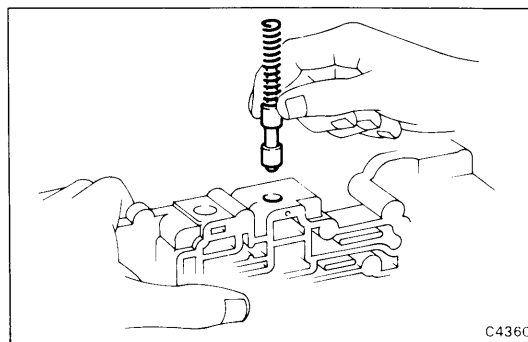

12. INSERT LOCK-UP SIGNAL VALVE, SPRING AND PLUG

Insert the lock-up signal valve (large end first), spring and plug with the small end first.

13. INSTALL LOCK UP SIGNAL VALVE LOCATING PIN

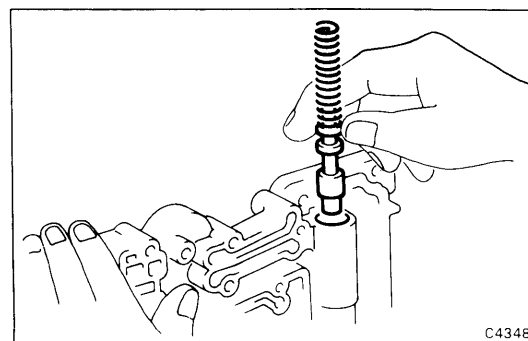

14. INSERT PRIMARY REGULATOR VALVE AND SPRING

Set the valve body on the edge and drop in the valve with the large end first and the spring.

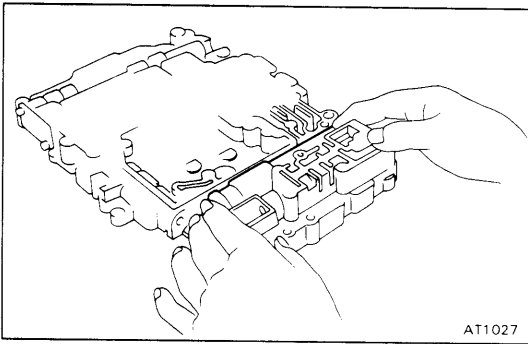
**15. CHECK VALVE POSITION**

Make sure that the primary regulator valve fits flush with the valve body.

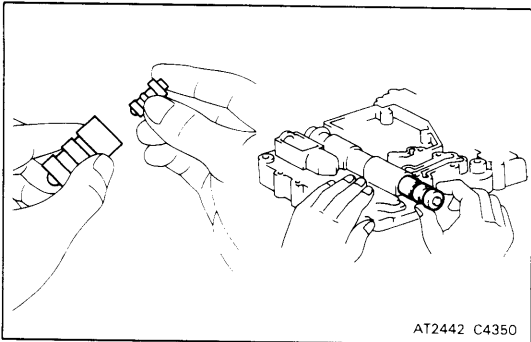
**16. INSERT REGULATOR VALVE PLUNGER INTO SLEEVE**

Insert with the rounded end first. Make sure that it is fully inserted: the plunger should be recessed inside the sleeve.

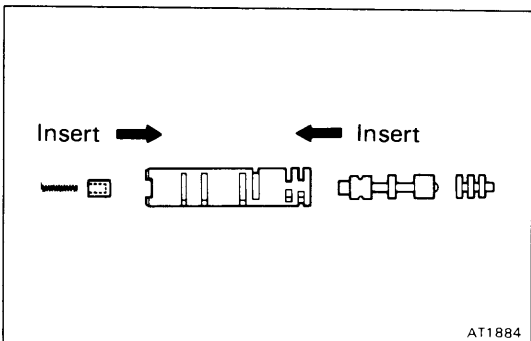
17. INSERT SLEEVE WITH PLUNGER**18. INSTALL REGULATOR VALVE SPRING RETAINER****19. INSERT LOCK-UP RELAY VALVE**

(a) Assemble the spring, lock-up relay control valve, lock-up relay valve and plug into the sleeve.

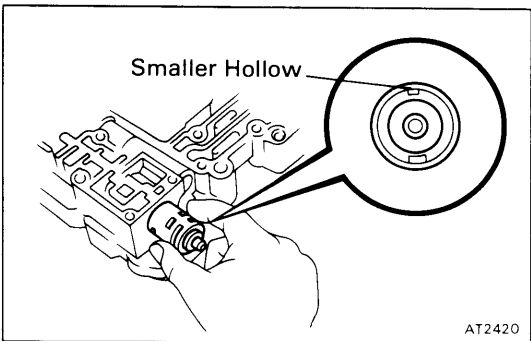

(b) Insert the sleeve into the bore.

NOTE: Insert the sleeve with the smaller hollow on the sleeve top side facing upward as shown in the figure.

(c) Install the plug retainer.

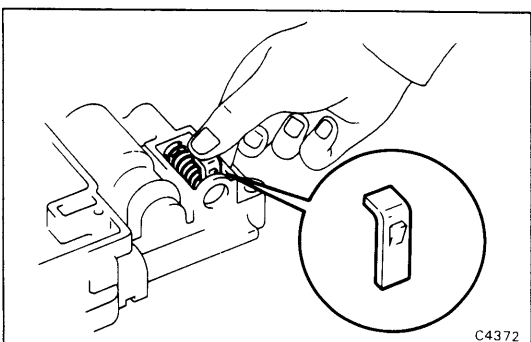
**20. INSTALL PRESSURE RELIEF BALL, SPRING AND RETAINER**

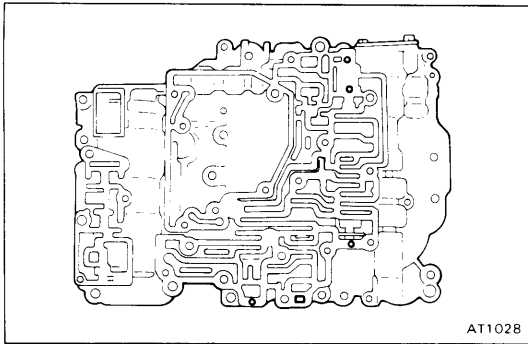

21. CHECK RETAINERS AND LOCATING PINS

Make sure that the retainers and pins are installed correctly.

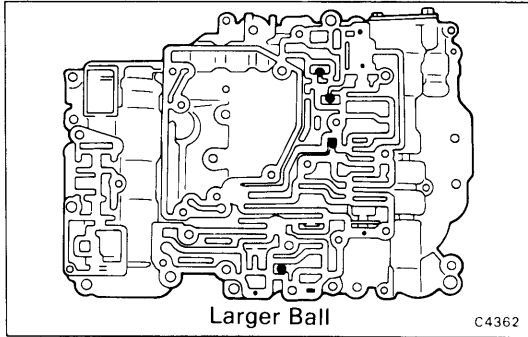

22. INSTALL FOUR CHECK BALLS

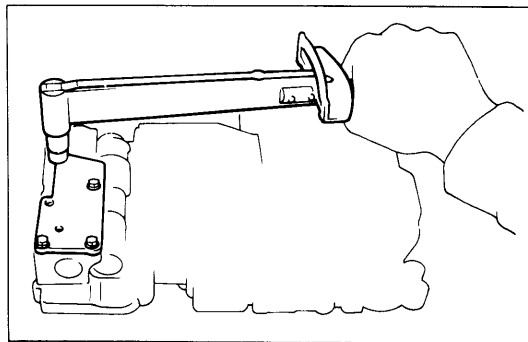

23. INSTALL PLATE WITH GASKET

Tighten the four bolts.

Torque: 55 kg-cm (48 in.-lb, 5.4 N·m)

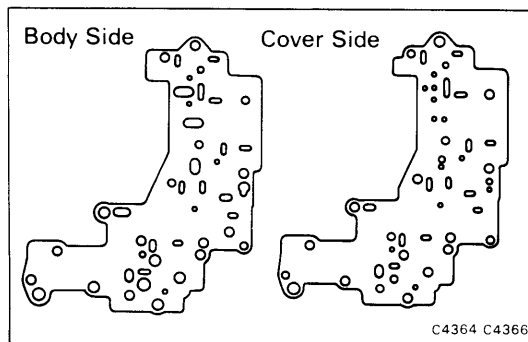

24. INSTALL LOWER BODY COVER

Install in the following order.

Gasket-plate-gasket-cover.

NOTE: The two gaskets are not interchangeable.

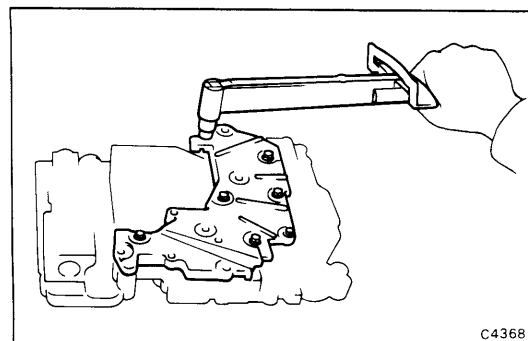

25. INSTALL LOWER BODY COVER SET BOLTS

Torque: 55 kg-cm (48 in.-lb, 5.4 N·m)

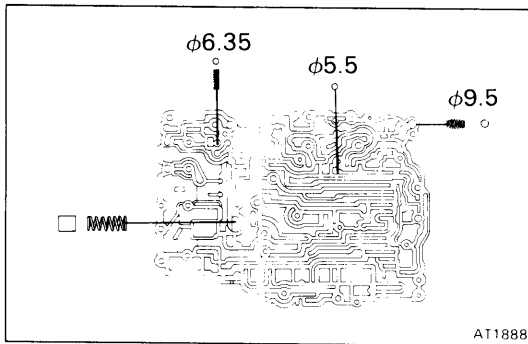

26. **INSTALL CHECK BALL, ($\phi 5.5$ mm/0.217 in.) DAMPING CHECK BALL, ($\phi 6.35$ mm/0.250 in.) SPRING, OIL COOLER BY-PASS VALVE, SPRING, COOLER RETURN BALL ($\phi 9.5$ mm/0.375 in.) AND SPRING**

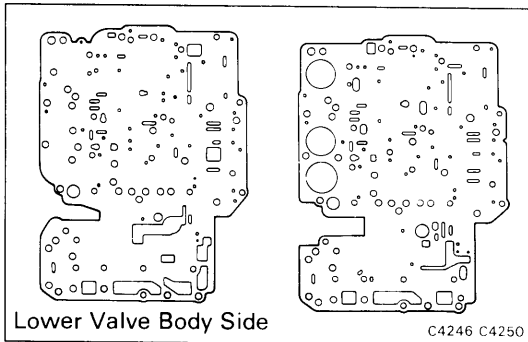

27. **INSTALL LOWER VALVE BODY GASKET**

Note that the two gaskets are not interchangeable. The gasket must lay flat on the valve body.

CAUTION: Make sure that the new gasket matches the old one.

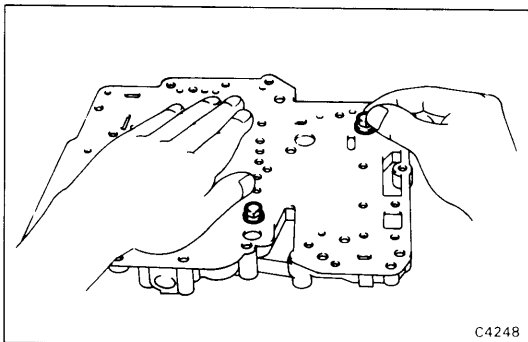

28. **INSTALL LOWER VALVE BODY PLATE**

Set the plate into place. Temporarily install the two short bolts finger tight to compress the plate against the spring-loaded check valve.

NOTE: Use the bolt for the oil strainer.

(Upper Front Valve Body)

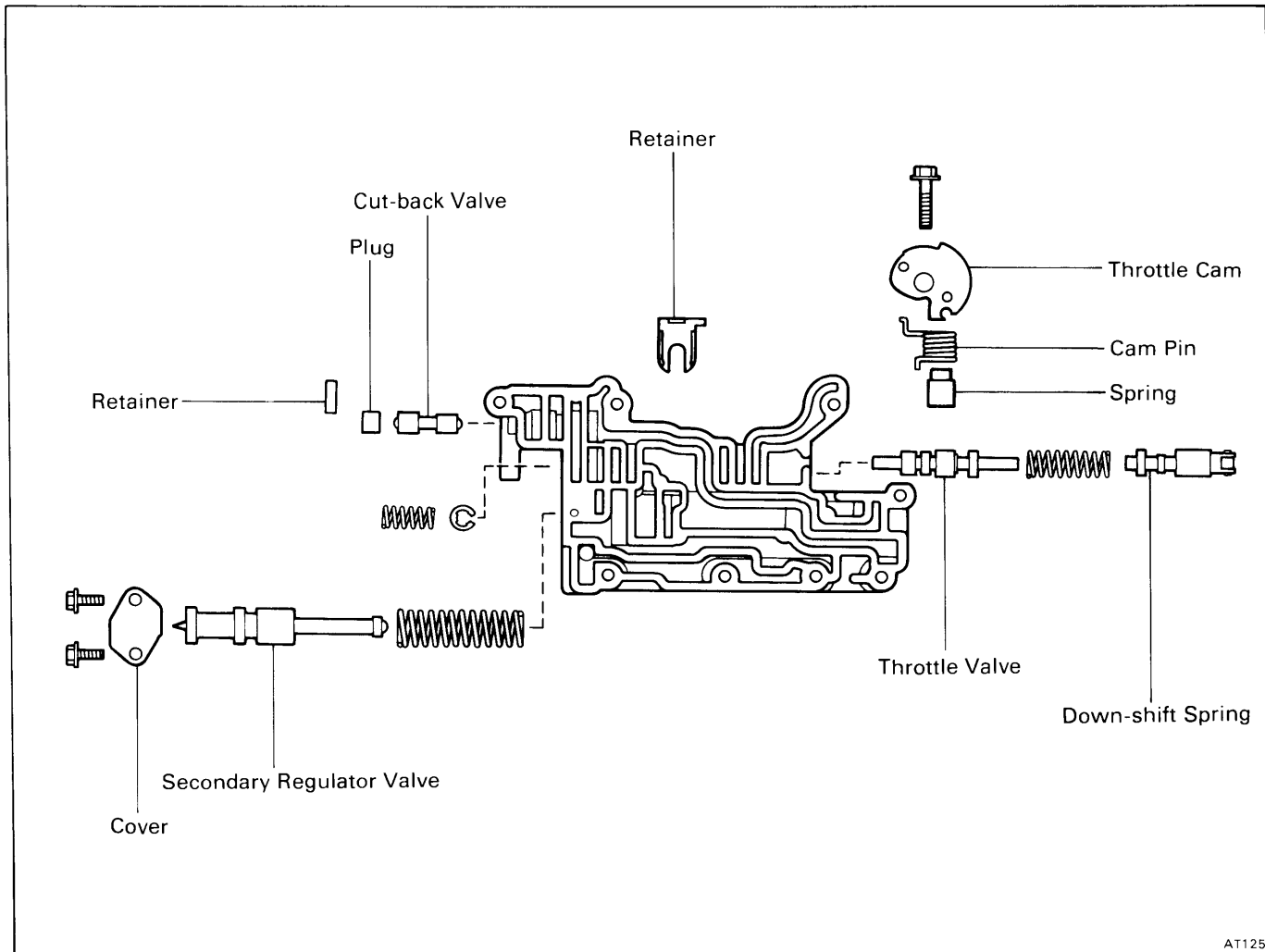

AT1251

DISASSEMBLY OF UPPER FRONT VALVE BODY

1. REMOVE RETAINER FOR CUT-BACK PLUG AND THROTTLE VALVE RETAINER
2. REMOVE PLUG AND CUT-BACK VALVE
3. REMOVE SECONDARY REGULATOR VALVE AND SPRING

(a) Remove one bolt from the plate over the valve and loosen the other one. Slowly rotate the plate to uncover the valve.

WARNING: The valve is spring loaded.

(b) Remove the valve and spring. Keep the spring with the valve.

(c) Remove the other bolt and remove the cover plate.

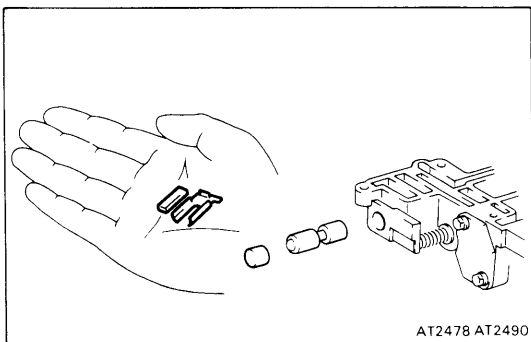

AT2478 AT2490

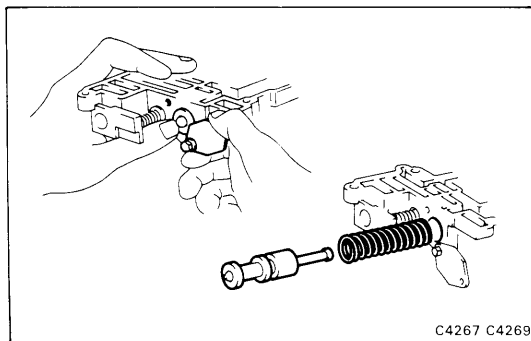

C4267 C4269

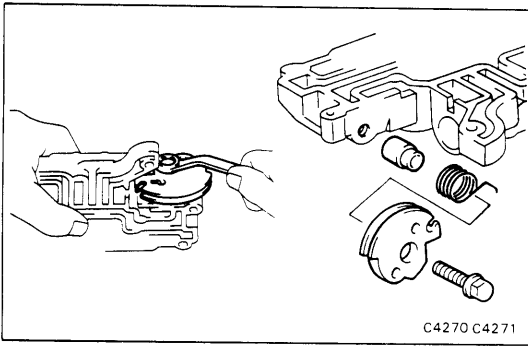

4. **PUSH DOWN-SHIFT PLUG INTO VALVE BODY AND TEMPORARILY HOLD IN THROTTLE VALVE**
Temporarily hold the throttle valve in position with the cut-back valve plug retainer.

5. **REMOVE THROTTLE CAM**

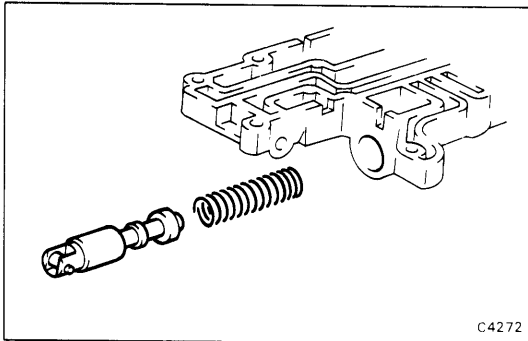

6. **REMOVE DOWN-SHIFT PLUG AND SPRING**
Press on the down-shift plug so that the temporary retainer falls out.

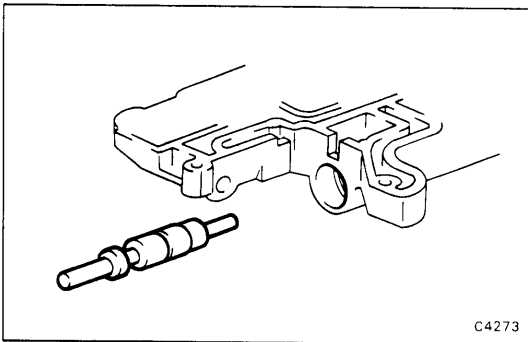

7. **REMOVE THROTTLE VALVE**
8. **REMOVE SPRING AND ADJUSTING RINGS**
Note the number of adjusting rings installed.

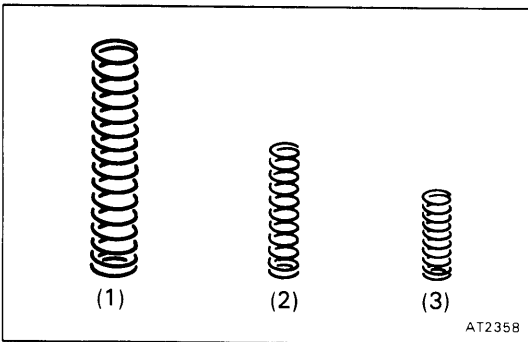

INSPECTION OF UPPER FRONT VALVE BODY
INSPECT VALVE SPRINGS

Check for damage, squareness, rust and collapsed coils. Measure the spring free height and replace if less than that shown below.

	Free length mm (in.)	Color
(1) Secondary regulator valve	71.27 (2.8059)	Green
(2) Down-shift plug	39.76 (1.5654)	Purple
(3) Throttle valve	21.94 (0.8638)	None

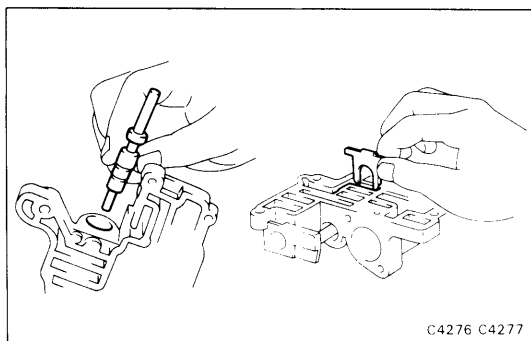

ASSEMBLY OF UPPER FRONT VALVE BODY

(See page AT-78)

1. INSERT THROTTLE VALVE

Note the arrangement in the photo. Make sure that the valve is inserted fully into the bore.

2. INSTALL THROTTLE VALVE RETAINER

Coat the clip with petroleum jelly to keep it in place. Note position of the tabs in the figure. Slip the retainer into place in the valve body.

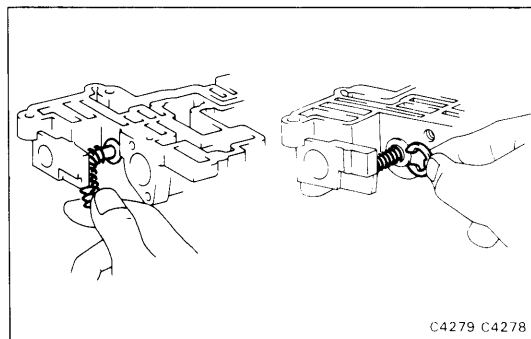

3. INSTALL ADJUSTING RINGS AND SMALL SPRING ON THROTTLE VALVE SHAFT

- (a) Slip the spring over the end of the valve shaft. Compress and slide it into place.
- (b) Install the same number of adjusting rings as were removed during disassembly.

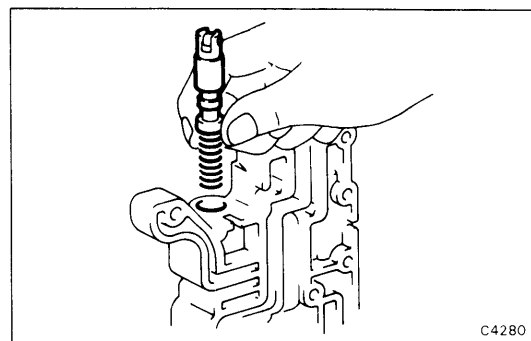

4. INSERT SPRING AND DOWN-SHIFT PLUG

5. TEMPORARILY INSTALL RETAINER OF CUT-BACK PLUG TO HOLD DOWN-SHIFT PLUG IN PLACE

Push the down-shift plug into the valve body and temporarily install the retainer.

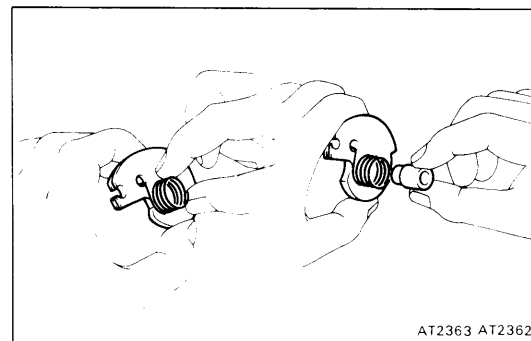

6. ASSEMBLE THROTTLE CAM

- (a) Install the spring with the hook through the hole in the cam.
- (b) Insert the sleeve through one side of the cam.

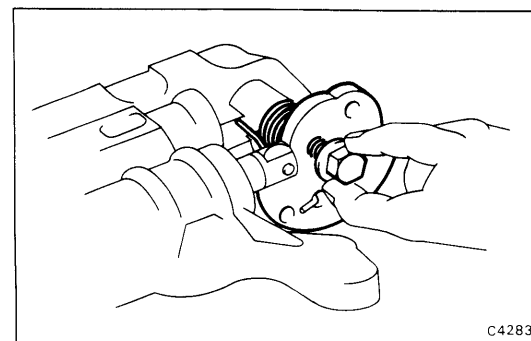

7. INSTALL CAM ASSEMBLY ON UPPER FRONT VALVE BODY

Check the position of the spring ends against the figure. Tighten the bolt.

Torque: 75 kg-cm (65 in.-lb, 7.4 N·m)

8. REMOVE TEMPORARILY INSTALLED RETAINER

NOTE: After assembly, check that the cam rotates smoothly throughout its full stroke.

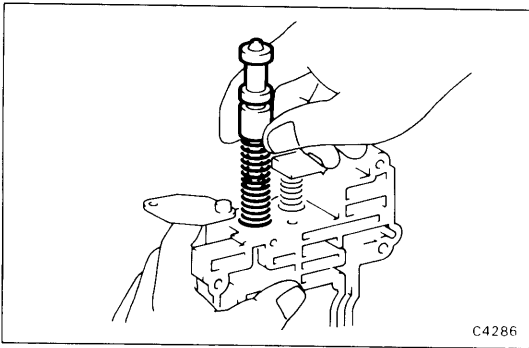
**9. INSTALL SECONDARY REGULATOR VALVE**

- (a) Partially install the cover plate and insert the spring and secondary regulator valve.
- (b) Compress the spring and swing the cover plate into place.
- (c) Install the second bolt in the cover plate and tighten both bolts.

Torque: 55 kg-cm (48 in.-lb, 5.4 N·m)

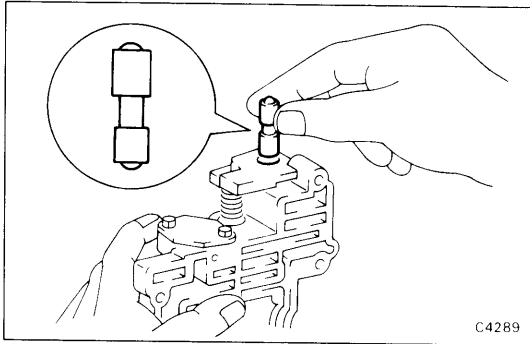
**10. INSERT CUT-BACK VALVE AND PLUG**

Install the valve with the smaller end first.

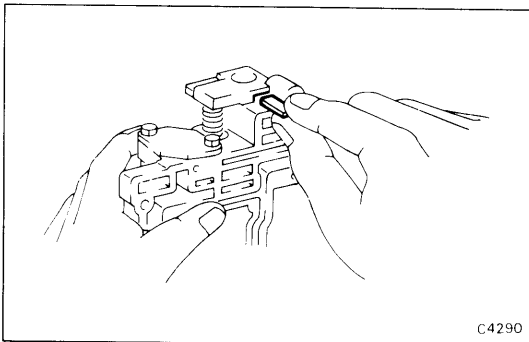
**11. INSTALL CUT-BACK VALVE RETAINER**

Coat the valve with petroleum jelly to keep in place.

(Upper Rear Valve Body)

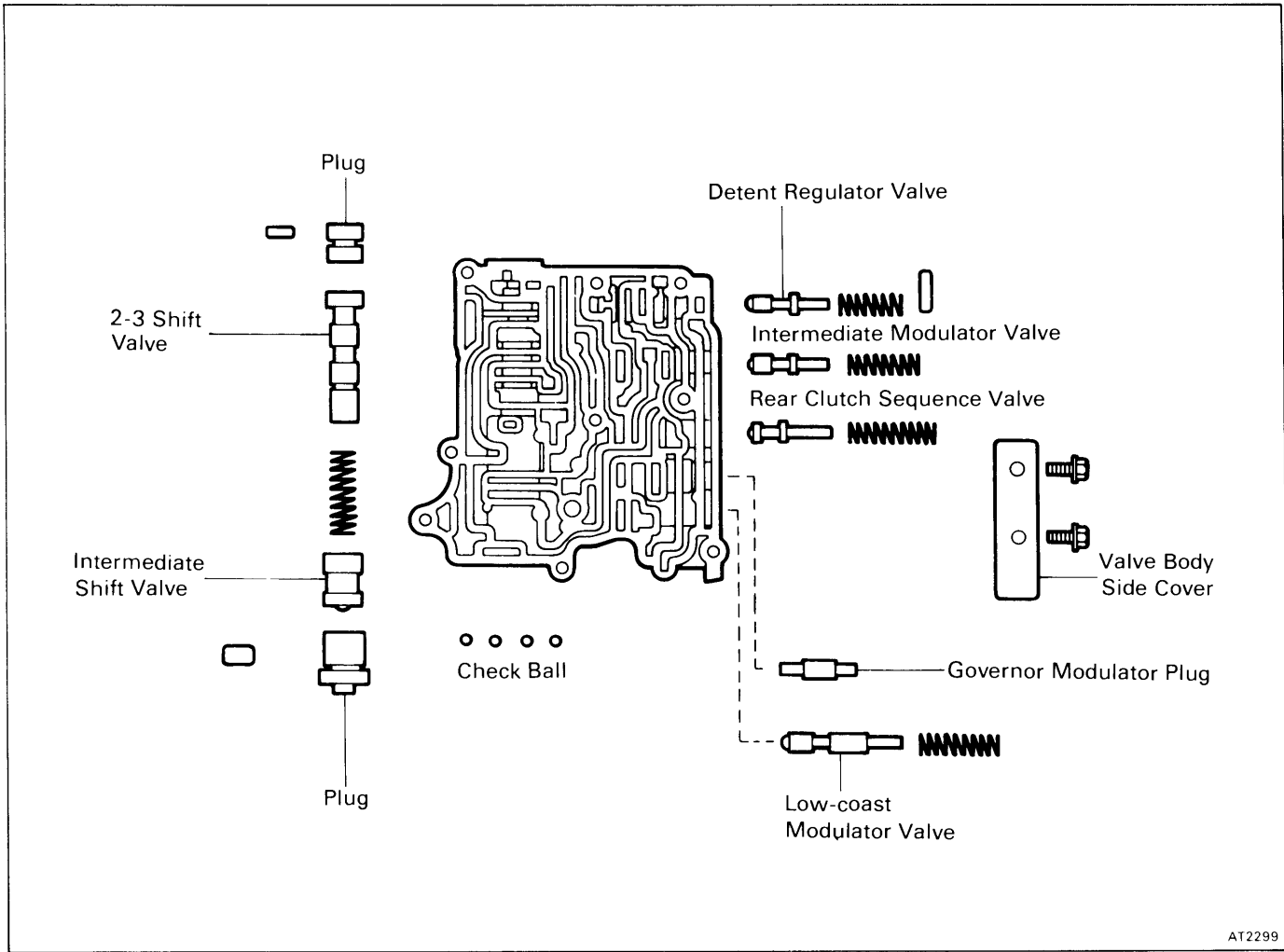

AT2299

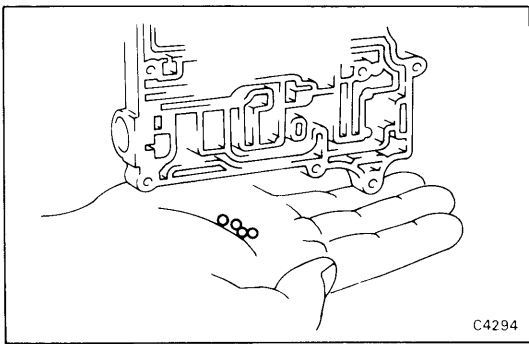

C4294

DISASSEMBLY OF UPPER REAR VALVE BODY

1. REMOVE CHECK BALLS WITH TWEEZERS

Three rubber balls and one steel ball.

2. REMOVE INTERMEDIATE SHIFT VALVE RETAINER

3. REMOVE PLUG, INTERMEDIATE SHIFT VALVE AND SPRING

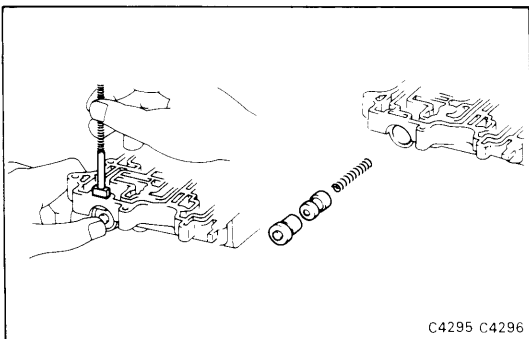

C4295 C4296

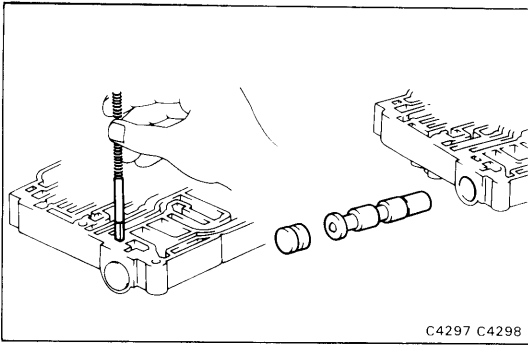
**4. REMOVE 2-3 SHIFT VALVE**

- (a) Remove the 2-3 shift valve retainer.
- (b) Remove the plug and 2-3 shift valve.

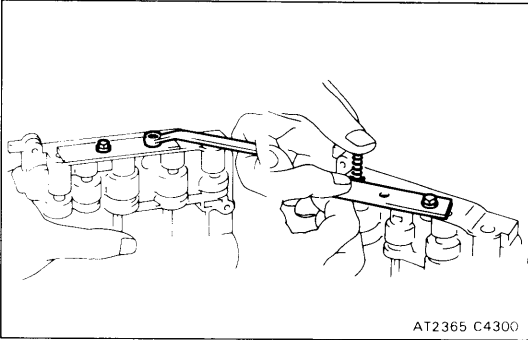
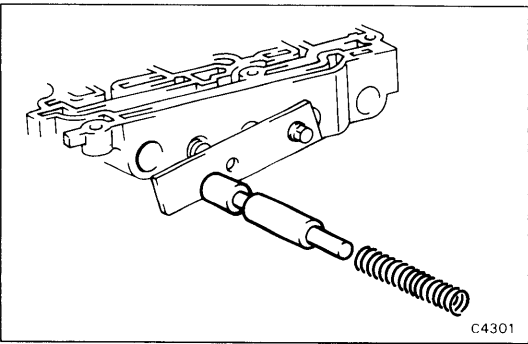
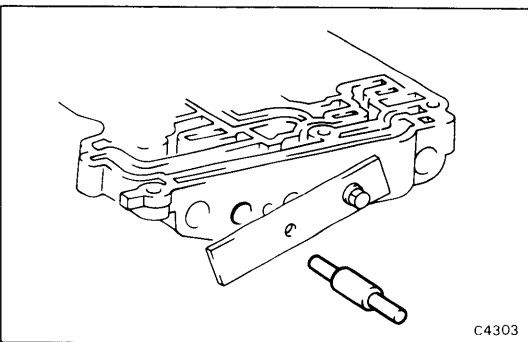
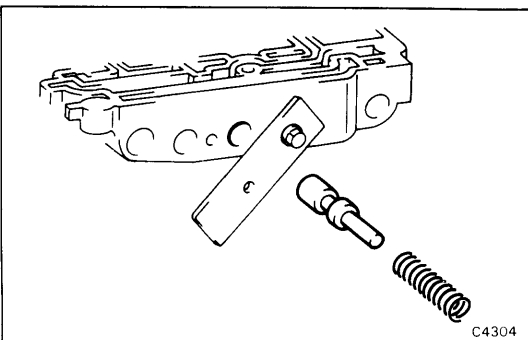
**5. REMOVE ONE BOLT FROM VALVE BODY SIDE COVER****6. SLIGHTLY ROTATE COVER TO RELEASE LOW-COAST MODULATOR VALVE ONLY****7. REMOVE SPRING AND LOW-COAST MODULATOR VALVE****8. ROTATE COVER FURTHER AND REMOVE GOVERNOR MODULATOR PLUG****9. ROTATE COVER FURTHER AND REMOVE SPRING AND REAR CLUTCH SEQUENCE VALVE**

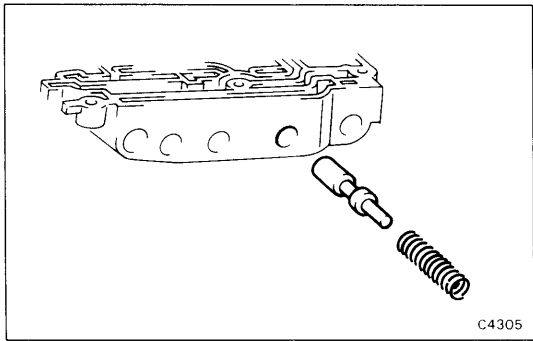

10. REMOVE COVER PLATE, SPRING AND INTERMEDIATE MODULATOR VALVE

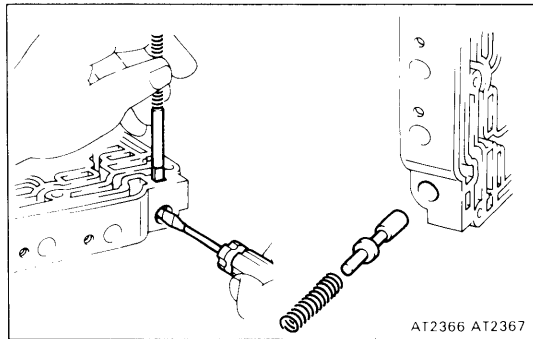

11. REMOVE DETENT REGULATOR VALVE RETAINER

12. REMOVE SPRING AND DETENT REGULATOR VALVE

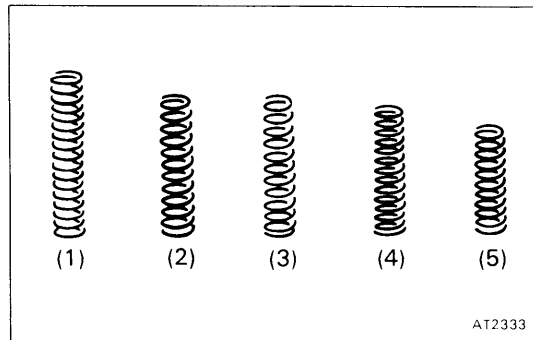

INSPECTION OF UPPER REAR VALVE BODY

INSPECT VALVE SPRINGS

Check for damage, squareness, rust and collapsed coils. Measure the spring free height and replace it if less than that shown below.

	Free length mm (in.)	Color
(1) Low-coast modulator valve	42.35 (1.6673)	None
(2) Rear clutch sequence valve	37.55 (1.4783)	Red
(3) 2-3 shift valve	35.10 (1.3819)	White
(4) Detent regulator valve	32.08 (1.2630)	None
(5) Intermediate modulator valve	27.26 (1.0732)	Green

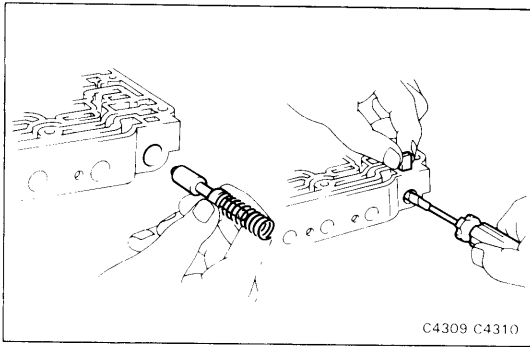

ASSEMBLY OF UPPER REAR VALVE BODY

(See page AT-91)

1. INSTALL DETENT REGULATOR VALVE, SPRING AND RETAINER

Insert the valve (round end first) and spring into the bore. Compress the spring with a large screwdriver and slip the retainer over the edge of the spring. Then compress the spring and allow the retainer to fall into place.

NOTE: Make sure that the retainer fully covers the end of the spring.

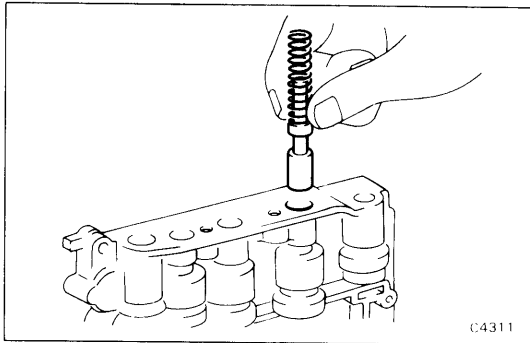

2. INSERT INTERMEDIATE MODULATOR VALVE AND SPRING

Insert the valve with the round end first, and then insert the spring.

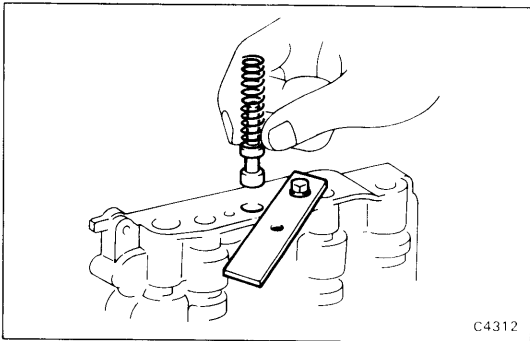

3. INSTALL VALVE BODY SIDE COVER WITH ONE BOLT

4. INSERT REAR CLUTCH SEQUENCE VALVE AND SPRING

Insert the valve with the round end first, and then insert the spring.

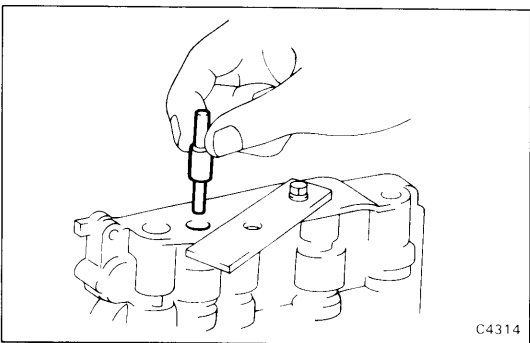

5. INSERT GOVERNOR MODULATOR PLUG

6. INSERT LOW MODULATOR VALVE AND SPRING

Insert the valve with the round end first, and then insert the spring.

7. POSITION COVER AND INSTALL SECOND BOLT

Install the 2nd bolt, and then tighten both bolts.

Torque: 55 kg-cm (48 in.-lb, 5.4 N·m)

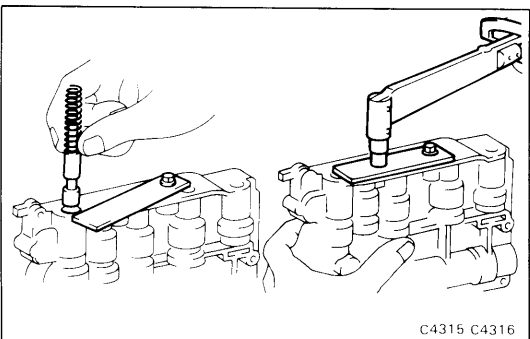

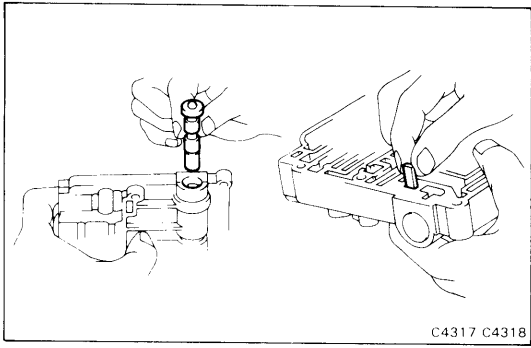
**8. INSERT 2-3 SHIFT VALVE**

- (a) Insert the 2-3 shift valve with the smaller end first, and then insert the plug.
- (b) Compress plug and install the intermediate shift valve retainer in the valve body.

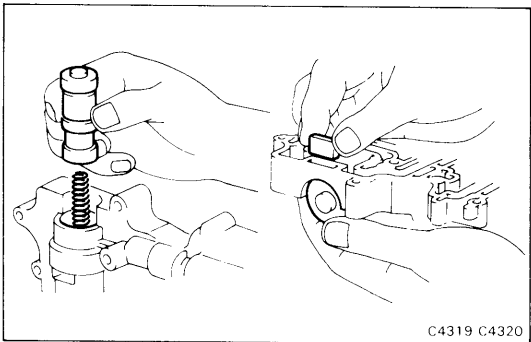
**9. INSERT SPRING AND INTERMEDIATE SHIFT VALVE INTO BORE**

Insert valve with the round end upwards.

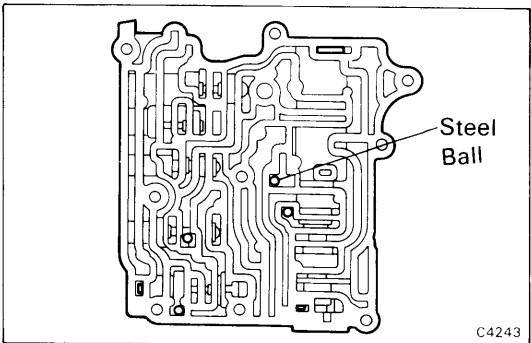
10. INSERT PLUG AND RETAINER**11. INSTALL CHECK BALLS AS SHOWN**

Install the steel ball in the position shown in the figure. The three rubber balls are identical and may be installed in any other of the positions.

(Assembly of Valve Body)

1. POSITION NEW GASKET ON UPPER REAR VALVE BODY

Make sure that the new gasket matches the old gasket before installation. Align the gasket at the lower right corner.

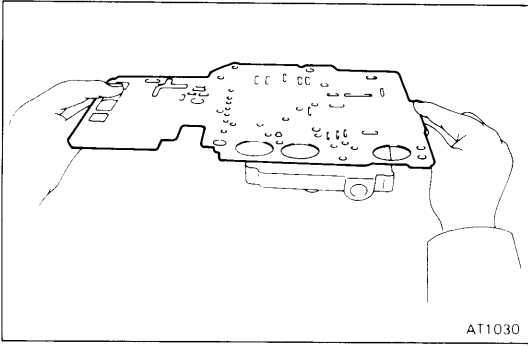

2. PLACE LOWER VALVE BODY WITH PLATE ON TOP OF UPPER REAR VALVE BODY

Align the right edge.

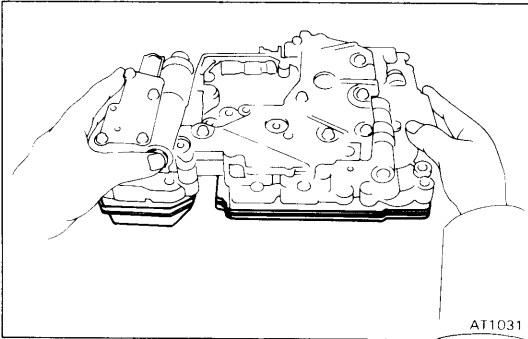

3. INSTALL AND FINGER TIGHTEN THREE BOLTS IN LOWER VALVE BODY TO SECURE UPPER REAR VALVE BODY

NOTE: Each bolt length (mm) is indicated in the figure.

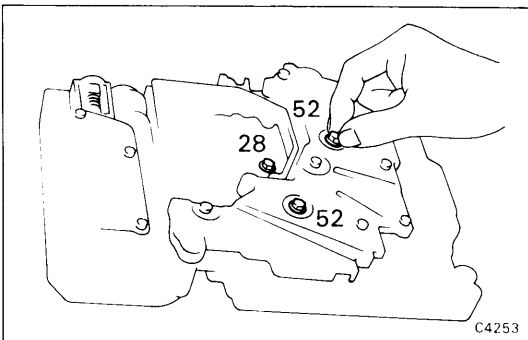

4. TURN ASSEMBLY OVER, CHECK GASKET ALIGNMENT AND FINGER TIGHTEN FIVE BOLTS IN UPPER REAR VALVE BODY

NOTE: Each bolt length (mm) is indicated in the figure.

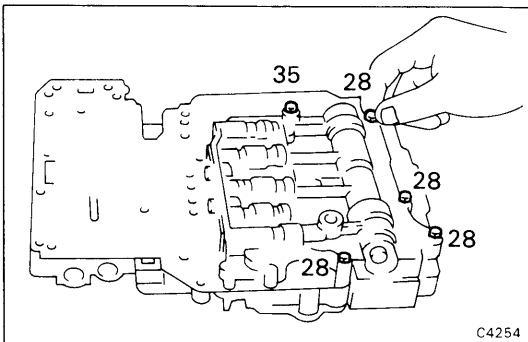

5. REMOVE TEMPORARY BOLTS FROM PLATE

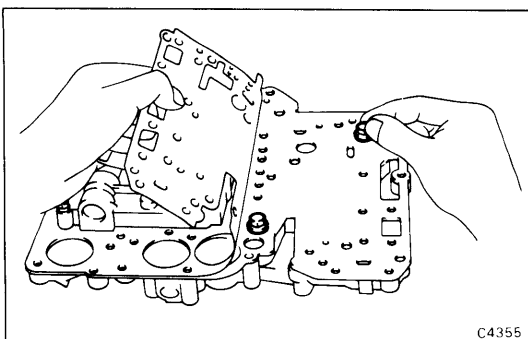

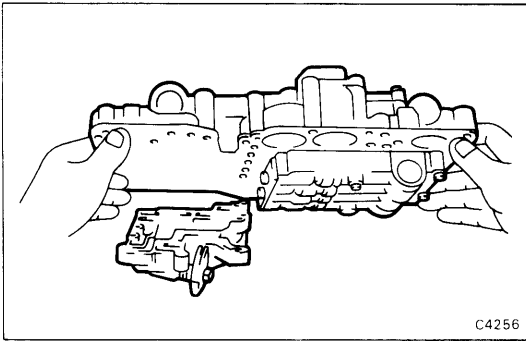

6. PLACE LOWER AND UPPER REAR VALVE BODY ASSEMBLY ON TOP OF UPPER FRONT VALVE BODY

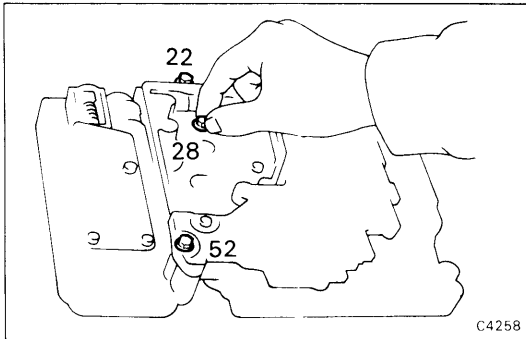

7. FINGER TIGHTEN SET BOLTS IN LOWER VALVE BODY TO SECURE UPPER FRONT VALVE BODY

NOTE: Each bolt length (mm) is indicated in the figure.

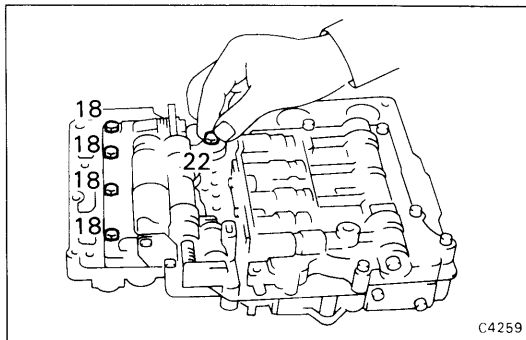

8. TURN ASSEMBLY OVER AND FINGER TIGHTEN FIVE BOLTS IN UPPER FRONT VALVE BODY

NOTE: Each bolt length (mm) is indicated in the figure.

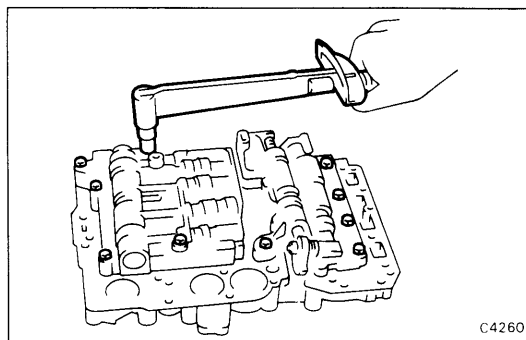

9. TIGHTEN BOLTS IN UPPER FRONT AND REAR VALVE BODIES

Recheck alignment of the gaskets. Tighten the bolts.

Torque: 55 kg-cm (48 in.-lb, 5.4 N·m)

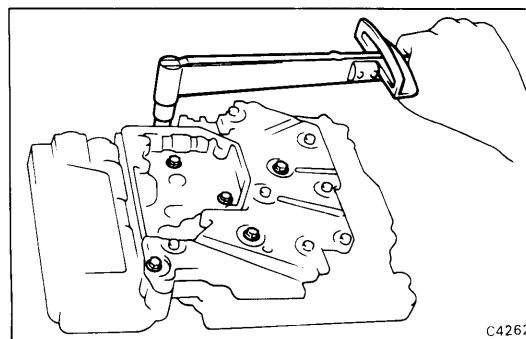

10. TURN ASSEMBLY OVER AND TIGHTEN BOLTS IN LOWER VALVE BODY

Tighten the bolts.

Torque: 55 kg-cm (48 in.-lb, 5.4 N·m)

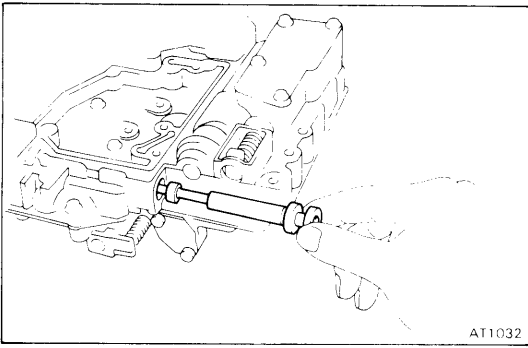
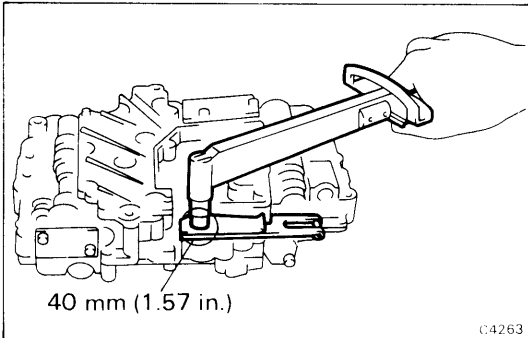
**11. INSERT MANUAL VALVE****12. INSTALL DETENT SPRING**

Tighten the bolts.

Torque: 55 kg-cm (48 in.-lb, 5.4 N·m)

Governor Body

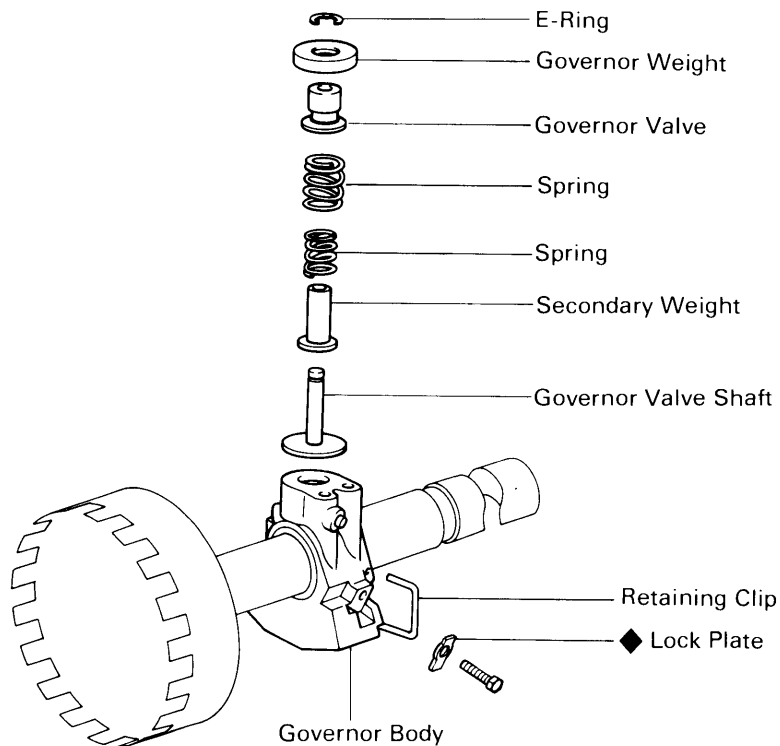

◆ Non-reusable part

AT0022

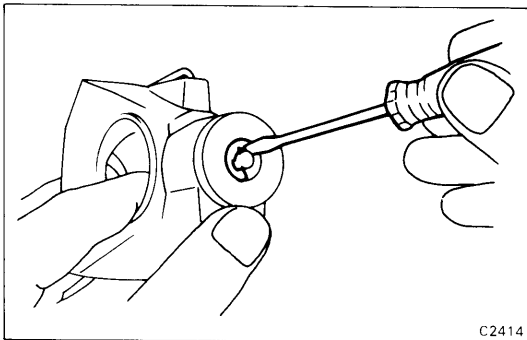

C2414

DISASSEMBLY OF GOVERNOR BODY

1. REMOVE E-RING AND GOVERNOR WEIGHT

Compress the spring by pushing up on the shaft and down on the weight. Remove the E-ring with a screwdriver. Lift off the governor weight.

2. REMOVE GOVERNOR VALVE

Slide it down through the bore.

3. REMOVE RETAINING CLIP

Remove the clip end, indicated by the arrow, being careful not to scratch the governor body.

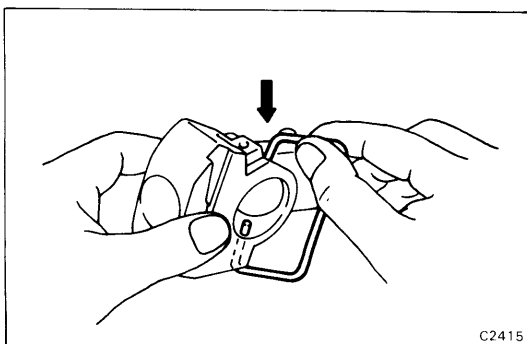

C2415

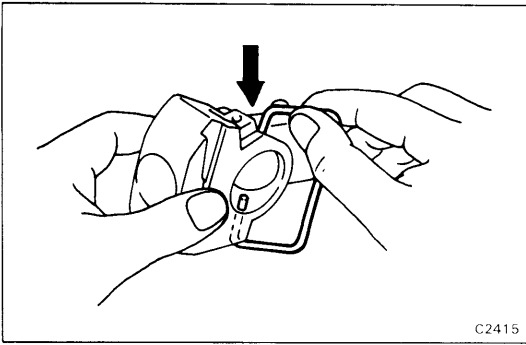

C2415

INSPECTION OF GOVERNOR BODY

ASSEMBLY OF GOVERNOR BODY

(See page AT-99)

1. INSTALL RETAINING CLIP

Install the clip end, indicated by the arrow, being careful not to scratch the governor body.

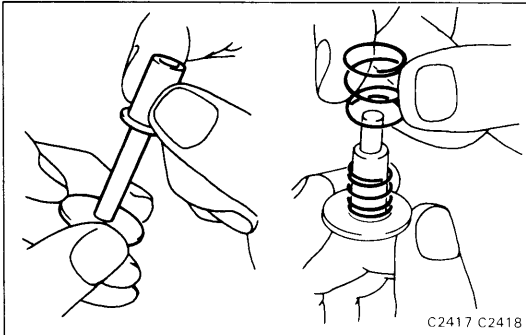

C2417 C2418

2. INSTALL GOVERNOR VALVE, WEIGHT, SPRINGS AND SHAFT

(a) Install the secondary weight to the shaft.

(b) Install the two springs.

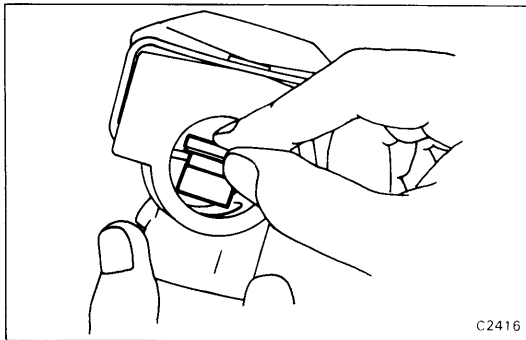

C2416

(c) Slide down the governor valve through the bore.

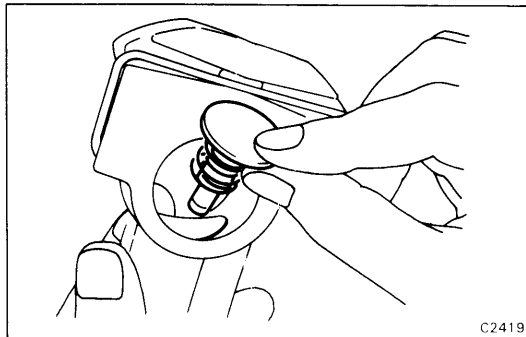

C2419

(d) Slide down the springs and shaft through the bore.

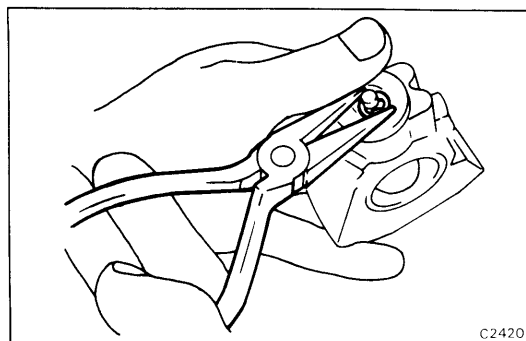

C2420

3. INSTALL GOVERNOR WEIGHT AND E-RING ON SHAFT

Compress the spring, and install the E-ring on the shaft with needle-nose pliers. Make sure that it is fully seated in the groove.

NOTE: Make sure that the valve moves smoothly.

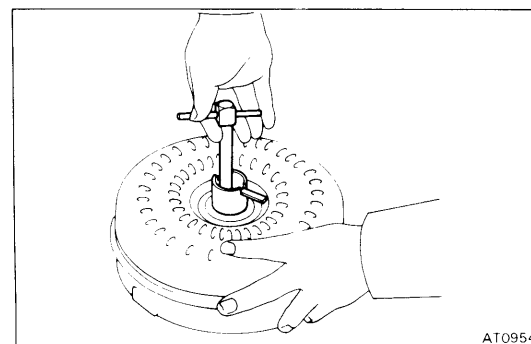
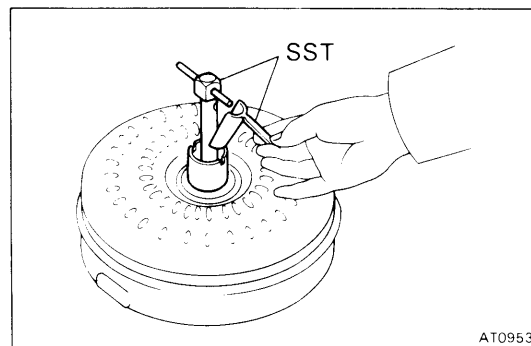
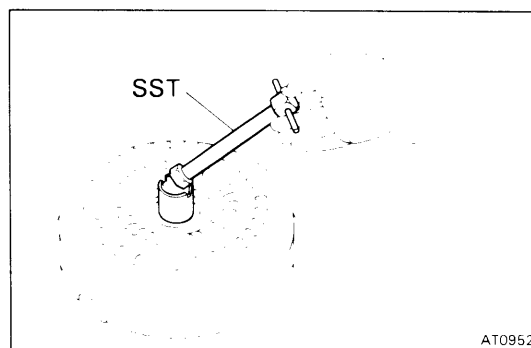
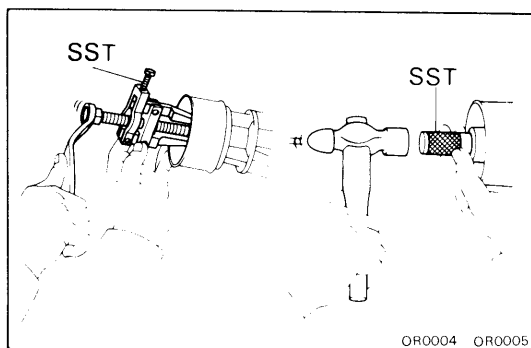
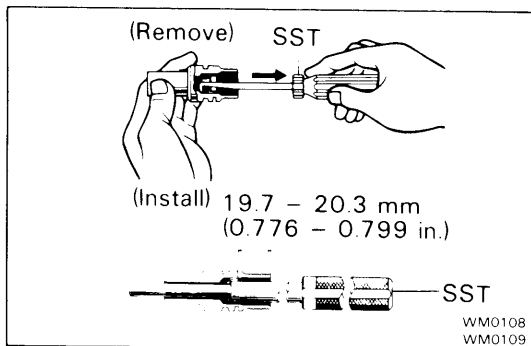

Extension Housing (2WD)

INSPECTION OF SPEEDOMETER GEAR AND EXTENSION HOUSING

1. IF NECESSARY, REPLACE SPEEDOMETER GEAR OIL SEAL

- Using SST, remove the oil seal.
SST 09921-00010
- Using SST, install a new oil seal.
SST 09201-60011

2. IF NECESSARY, REPLACE OIL SEAL AND DUST SEAL

- Using SST, remove the oil seal.
SST 09308-10010
- Using SST, drive in a new oil seal and dust seal.
SST 09325-20010

Torque Converter

CLEAN TORQUE CONVERTER

If the transmission is contaminated, the torque converter and transmission cooler should be thoroughly flushed, with Toyota Transmission Cleaner.

INSPECTION OF TORQUE CONVERTER

1. INSERT SST IN END OF TORQUE CONVERTER

- Insert a turning tool in to the inner race of the one-way clutch.
- Insert the stopper so that it fits in the notch of the converter hub and other race of the one-way clutch.
SST 09350-20015 (09397-22020)

2. TEST ONE-WAY CLUTCH

The clutch should lock when turned counterclockwise, and should rotate freely and smoothly clockwise. Less than 25 kg-cm (22 in.-lb, 2.5 N·m) of torque should be required to rotate the clutch clockwise. If necessary, clean the converter and retest the clutch. Replace the converter if the clutch still fails the test.

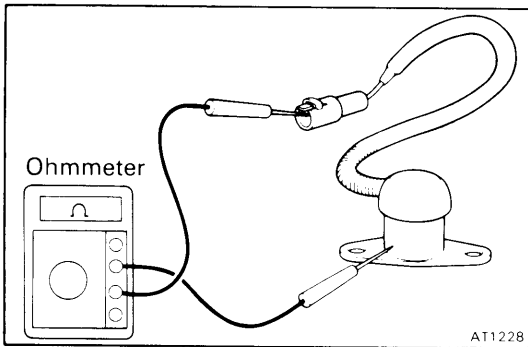

Electrical Parts

1. INSPECT OVERDRIVE SOLENOID

Check the resistance between the terminals.

Standard resistance: About 13 Ω

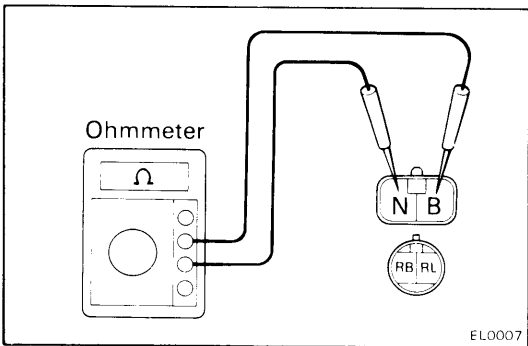

2. INSPECT NEUTRAL START SWITCH

Using an ohmmeter, check the continuity of the terminals for each switch position shown in the table below.

If continuity between the terminals is not as specified, replace the switch.

Range \ Terminal	Terminal			
	B	N	RB	RL
P	○	○		
R			○	○
N	○	○		

ASSEMBLY OF TRANSMISSION

Disassembly, inspection and assembly of each component group have been indicated in the preceding chapter.

Before assembly, make sure again that all component groups are assembled correctly.

GENERAL ASSEMBLY NOTES:

1. The automatic transmission is composed of highly precision-finished parts, necessitating careful inspection before assembly because even a small nick could cause fluid leakage or affect performance.
2. Before assembling new clutch discs, soak them in automatic transmission fluid for at least two hours.
3. Apply automatic transmission fluid on sliding or rotating surfaces of the parts before assembly.
4. Use petroleum jelly to keep the small parts in their places.
5. Do not use adhesive cement on gaskets and similar parts.
6. When assembling the transmission, be sure to use new gaskets and O-rings.
7. Dry all parts by blowing with compressed air. Never use shop rags.
8. Be sure to install the thrust bearings and races in the correct direction and position.

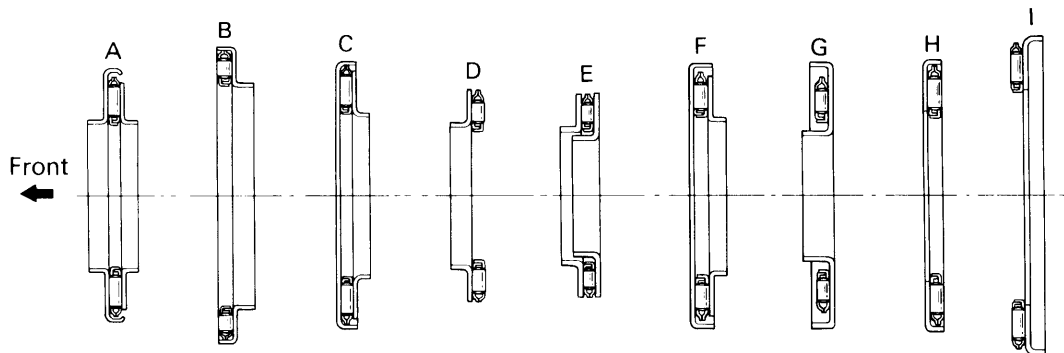
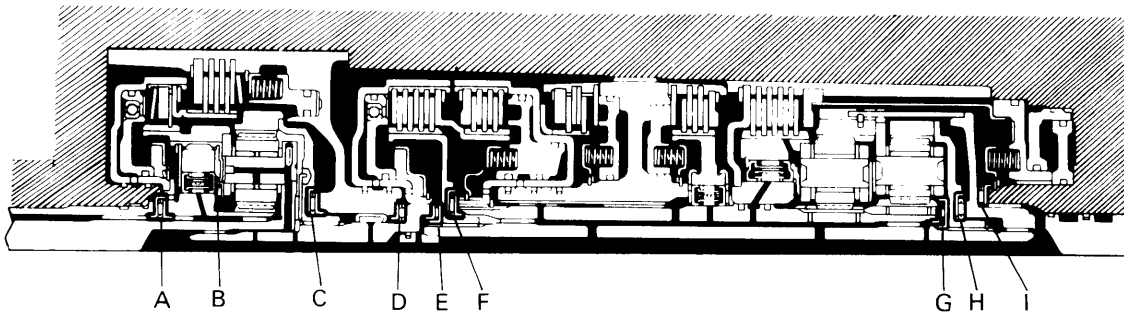

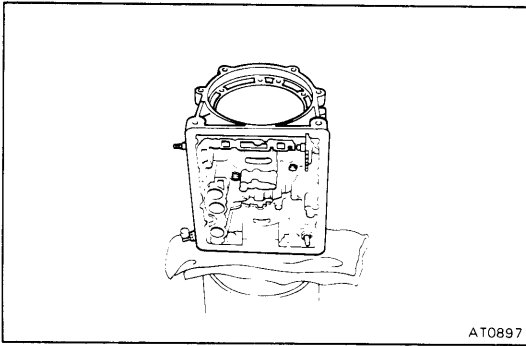

1. PLACE TRANSMISSION CASE ON CYLINDER

Place the transmission on a cylindrical stand for more efficient work.

CAUTION: Place shop rags between the case and stand to avoid damaging the case.

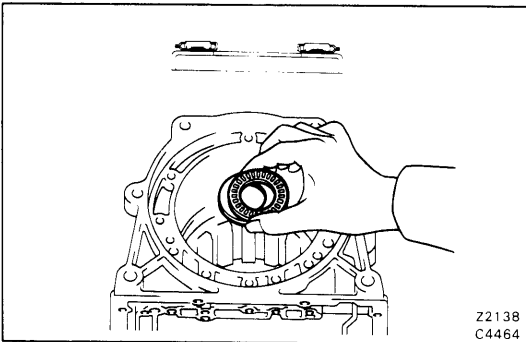

2. INSTALL THRUST WASHER AND BEARING

Install the thrust washer, facing the cup side downward.

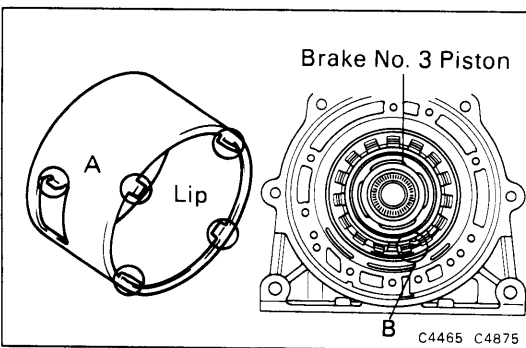

3. INSTALL APPLY TUBE ONTO OUTER PISTON OF REAR BRAKE PISTONS

Install the tube, aligning its locking tab (part A) with part B of the case.

NOTE: Make sure that the lips of the tube end are completely inserted onto the outer piston.

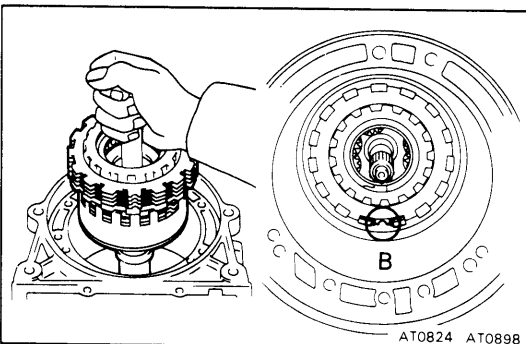

4. PARTIALLY INSERT OUTPUT SHAFT ASSEMBLY INTO CASE

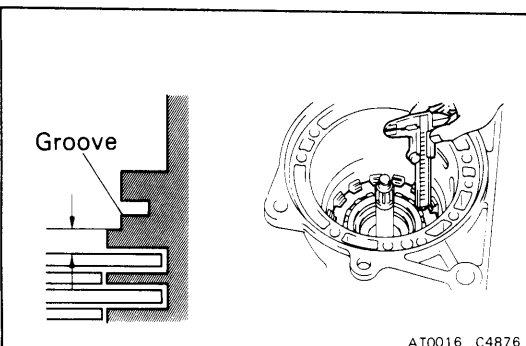

5. CHECK CLUTCH PACK CLEARANCE

With the case in upright position, make sure that the clutch pack is lower than the ledge below the snap ring groove.

If the clutch pack is not lower than the ledge, components may be misassembled or there may be excess ATF on the discs.

Standard clearance:

0.61 – 2.64 mm (0.0240 – 0.1039 in.)

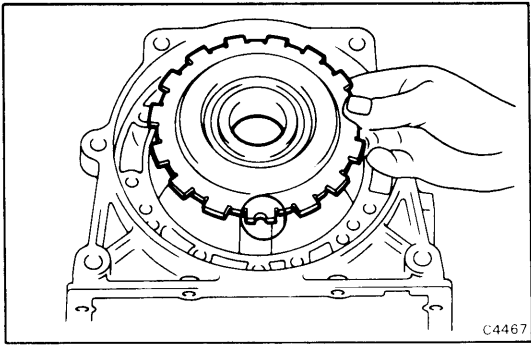
**6. INSTALL REACTION PLATE**

Position the notched tooth of the reaction plate toward the valve body side of the case. Push it into place.

NOTE: The reaction plate is correctly installed if the snap ring groove is fully visible.

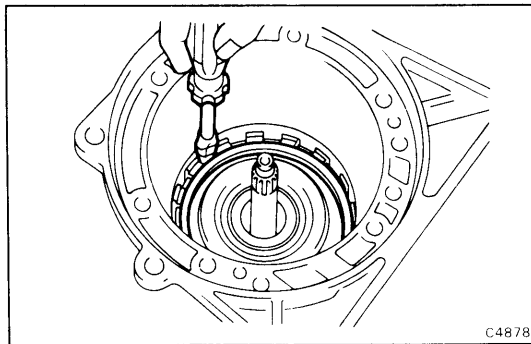
**7. INSTALL SNAP RING**

Use a large screwdriver to compress the snap ring. Push it into the place by hand. Work around the case. Visually check to make sure that the ring is fully seated. Make sure that the ends of the snap ring are between the lugs.

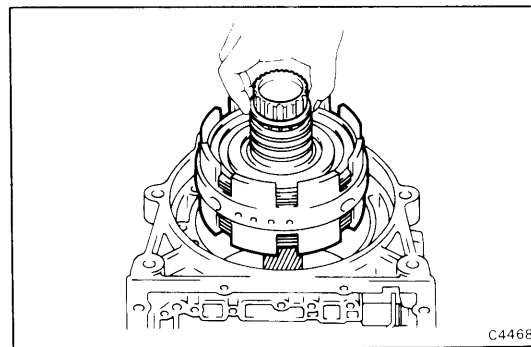
**8. PUSH CENTER SUPPORT ASSEMBLY INTO CASE**

Align the oil hole and bolt hole of the center support with those of the body side and insert.

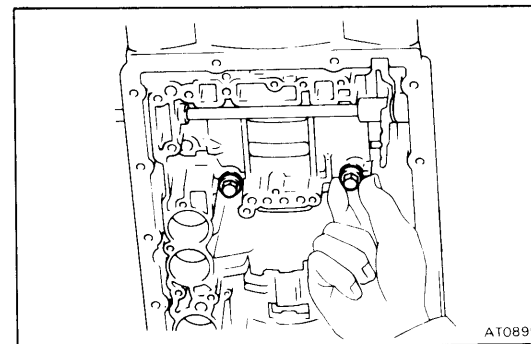
**9. INSTALL TWO CENTER SUPPORT BOLTS WITH WAVE WASHERS**

Align the center support with holes in case and install the two bolts finger tight.

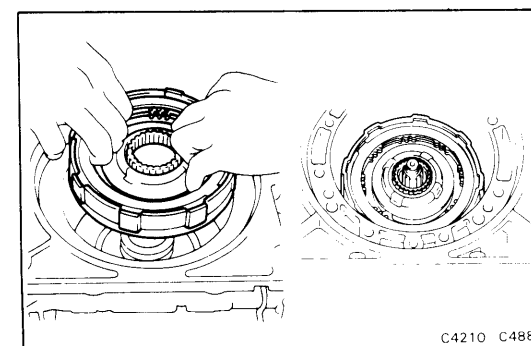
**10. INSTALL REAR CLUTCH IN CASE**

Rotate the clutch to mesh the hub with the center support.

11. CHECK FOR CORRECT INSTALLATION OF REAR CLUTCH

If the rear clutch is fully meshed with the center support, the splined center of the clutch will be flush with the end of the sun gear shaft.

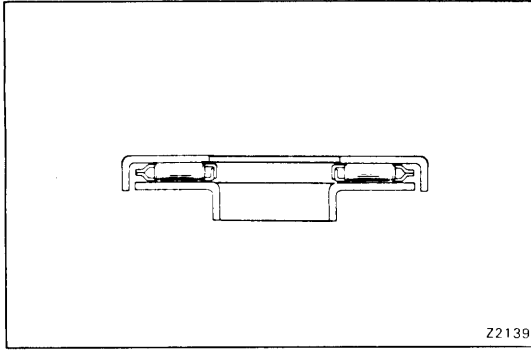

12. INSTALL THRUST BEARING RACE OVER SPLINED END OF REAR CLUTCH IN CASE

Coat parts with petroleum jelly to keep them in place. Position the lip of the race toward the rear clutch.

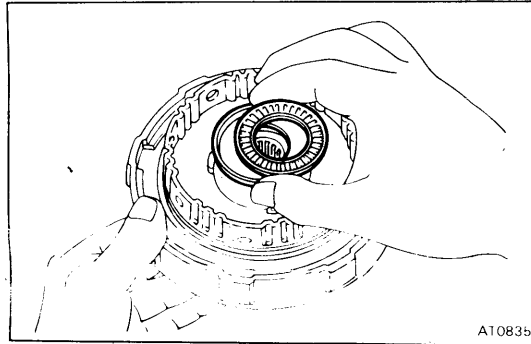

13. INSTALL THRUST BEARING AND RACE ON FRONT CLUTCH

Coat parts with petroleum jelly to keep them in the place. Position the lip of the race outward.

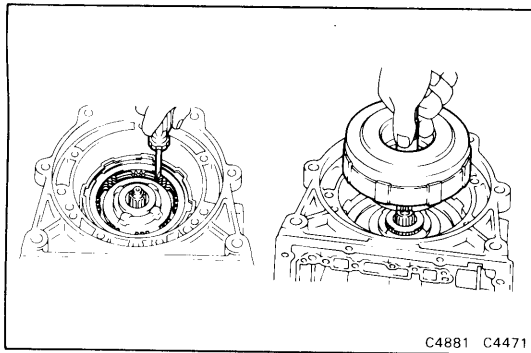

14. INSTALL FRONT CLUTCH ASSEMBLY IN CASE

Align the flukes of the rear clutch discs and mesh them with the front clutch hub. Push the front clutch assembly into the case.

CAUTION: Be careful that the thrust bearing does not fall out.

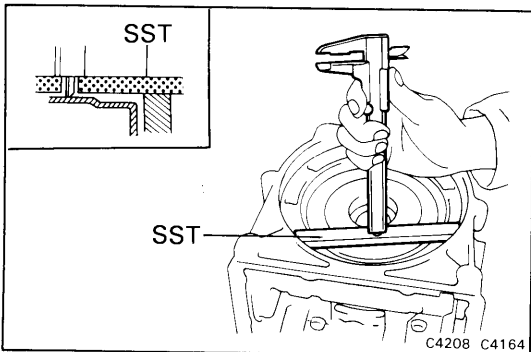

15. CHECK CORRECT INSTALLATION OF FRONT CLUTCH

Set SST on the transmission case as shown in the figure. Measure the distance between the top surface of SST and front clutch assembly. If the distance corresponds to that during disassembly, the front clutch is installed correctly.

SST 09350-20015 (09370-12010)

Height: Measured value minus SST width =
Approx. 2 mm (0.08 in.)

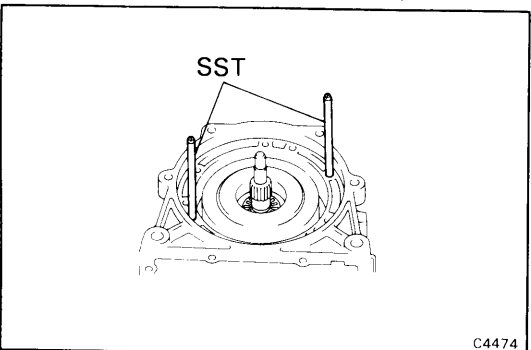

16. INSTALL SST ON CASE

Finger tighten the SST on the transmission case.

SST 09350-20015 (09362-30011)

17. INSTALL THRUST BEARING ON FRONT CLUTCH

Coat the thrust bearing with petroleum jelly and set it into place.

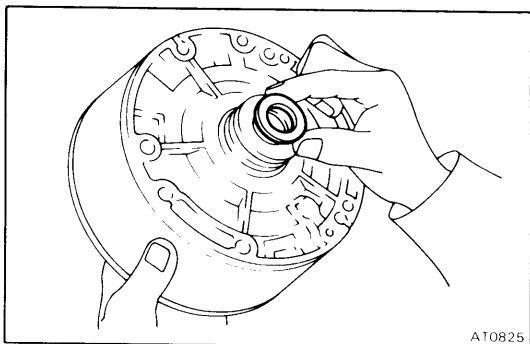

A10825

18. INSTALL OUTER RACE ON OVERDRIVE CASE END

Coat the outer race with petroleum jelly and set it into place facing lip side toward the overdrive case.

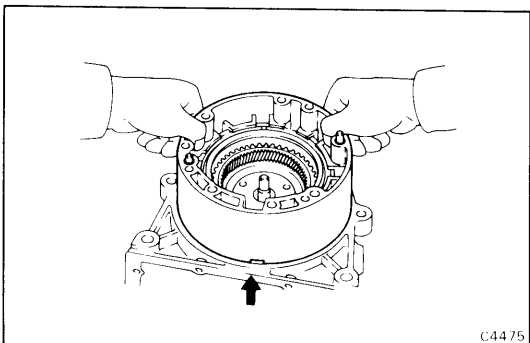

C4475

19. INSERT OVERDRIVE CASE INTO TRANSMISSION CASE

Insert the overdrive case gently through the two guide bolts (SST) with cut out portion of the case facing the direction shown in illustration.

SST 09350-20015 (09362-30011)

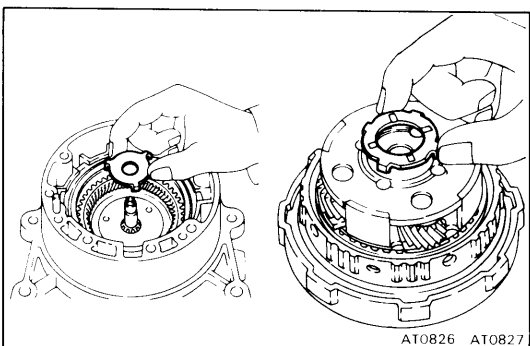

A10826 A10827

20. INSTALL THRUST WASHERS

Coat the thrust washers with petroleum jelly. Install thrust washer on the overdrive planetary carrier.

NOTE: The washer lugs should be inserted in the holes.

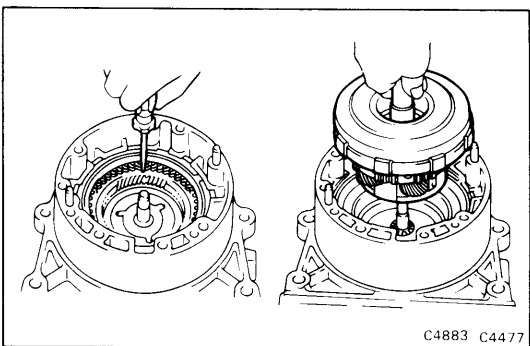

C4883 C4477

21. INSTALL OVERDRIVE CLUTCH IN CASE

Align the flukes of the discs in the overdrive case. Align the flukes with the slots of the overdrive clutch and press the overdrive clutch into the overdrive case.

CAUTION: Be careful that the thrust washer does not fall out.

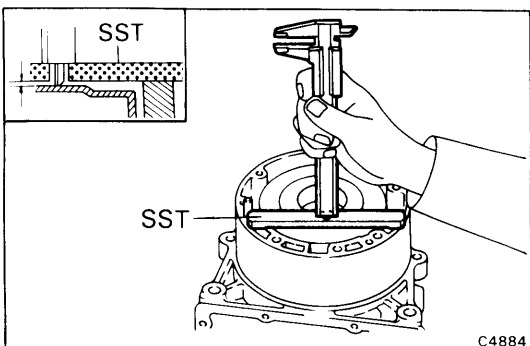

C4884

22. CHECK CORRECT INSTALLATION OF OVERDRIVE CLUTCH

Set SST on the overdrive case as shown in the figure. Measure the distance between the top surface of SST and overdrive clutch. If the distance corresponds to that during disassembly, the overdrive clutch is installed correctly.

SST 09350-20015 (09370-12010)

Height: Measured value minus SST width =
Approx. 3.5 mm (0.138 in.)

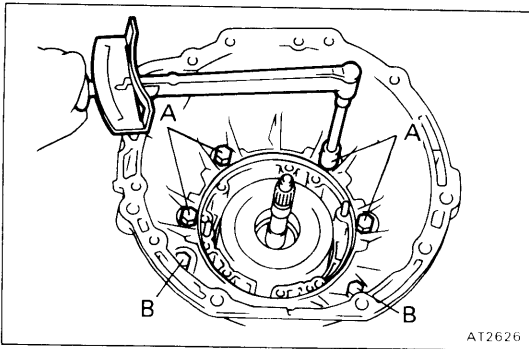
**23. INSTALL O-RING ON OVERDRIVE CASE****24. INSTALL CONVERTER HOUSING**

Install the two 12 mm bolts at B and four 10 mm bolts at A and tighten them.

Torque: A bolts 345 kg-cm (25 ft-lb, 34 N·m)
B bolts 580 kg-cm (42 ft-lb, 57 N·m)

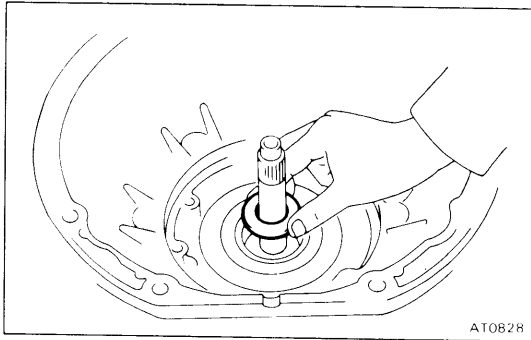
**25. INSTALL OUTER RACE ON OVERDRIVE CLUTCH**

Coat the outer race with petroleum jelly. Install the thrust washer facing the lip side outward inside.

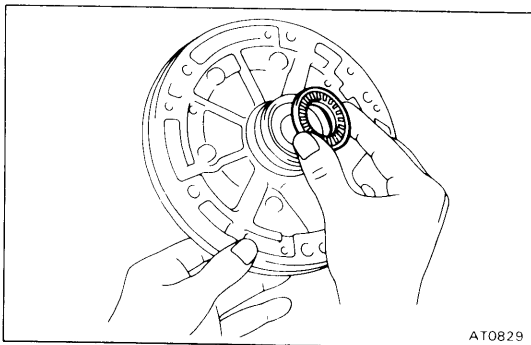
**26. INSTALL THRUST BEARING ON OIL PUMP**

Coat the thrust bearing with petroleum jelly and set into place.

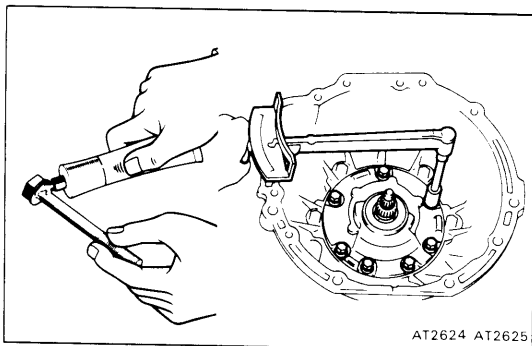
**27. INSTALL OIL PUMP**

(a) Install the oil pump gently through the two guide bolts, being careful that the thrust washer does not fall out.

(b) Coat the five set bolts with seal packing and finger tighten them.

Seal packing: Part No. 08833-00080, THREE BOND 1344, LOCTITE 242 or equivalent

(c) Using a screwdriver, remove the SST. In the place of it, install the two set bolts coated with seal packing.
SST 09350-20015 (09362-30011)

(d) Tighten the set bolts gradually and evenly.

Torque: 215 kg-cm (16 ft-lb, 21 N·m)

28. TIGHTEN TWO CENTER SUPPORT BOLTS

Tighten the bolts alternately in 70 kg-cm (61 in.-lb, 6.9 N·m) increments.

Torque: 260 kg-cm (19 ft-lb, 25 N·m)

NOTE: First tighten the accumulator piston side.

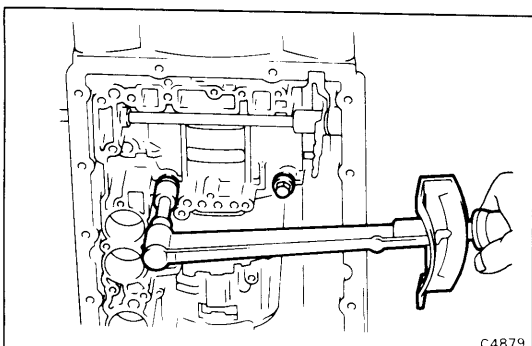

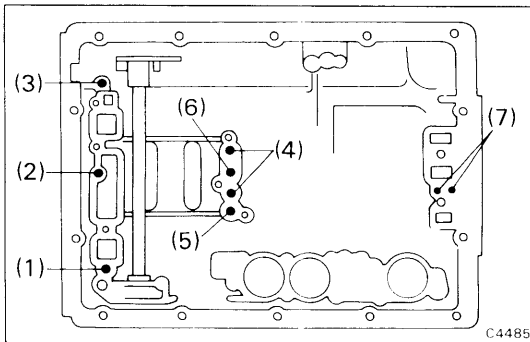

29. CHECK OPERATION OF PISTONS

Blow low-pressure compressed air into the passages indicated in the illustration and listen for noise from piston movement.

- (1) Overdrive clutch
- (2) Front clutch
- (3) Overdrive brake
- (4) Rear clutch
- (5) Brake No. 1
- (6) Brake No. 2
- (7) Brake No. 3

If the pistons do not move, disassemble and inspect.

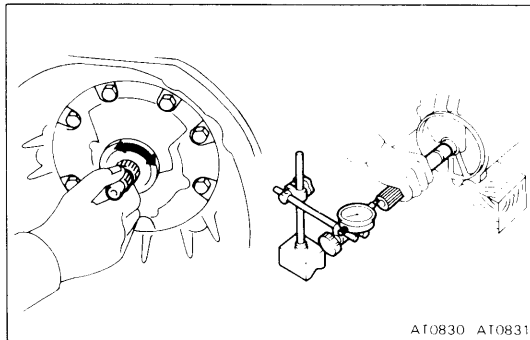

30. CHECK INPUT SHAFT AND OUTPUT SHAFT

- (a) Make sure that the input shaft has play in axial direction and that it turns.
- (b) Make sure that the output shaft has thrust play in axial direction.

Thrust play: 0.3 – 0.9 mm (0.012 – 0.035 in.)

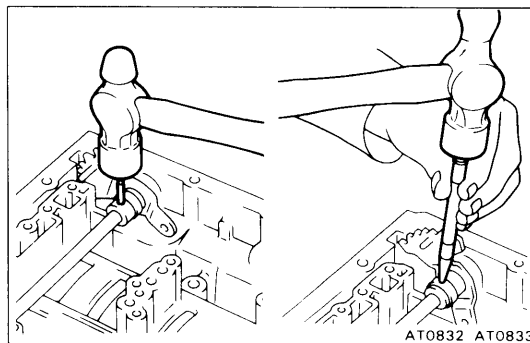

31. IF NECESSARY, INSTALL MANUAL VALVE LEVER SHAFT INTO CASE

- (a) Assemble a new collar to the manual valve lever.
- NOTE:** Always replace the collar and roll pin with new ones. Never reuse a pin after it has been removed.
- (b) Install the manual valve lever shaft to the transmission case through the manual valve lever.
 - (c) Drive in a new roll pin with the slot at a right angle to the shaft.
 - (d) Match the collar hole to the lever calking hollow and calk the collar to the lever.

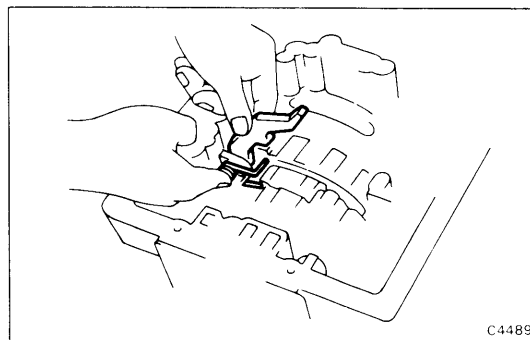

32. INSTALL PARKING LOCK PAWL, PIVOT PIN AND SPRING IN CASE

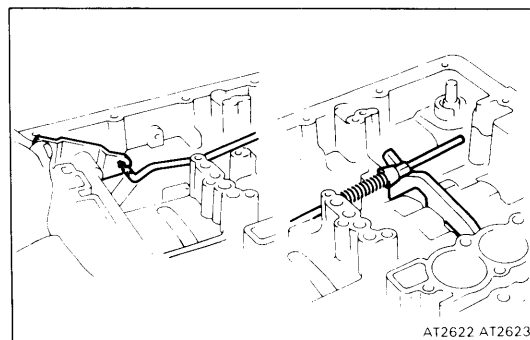

33. INSTALL PARKING LOCK ROD PAWL BRACKET ON CASE

- (a) Hook the parking lock rod to the manual valve and place it on the parking lock pawl.

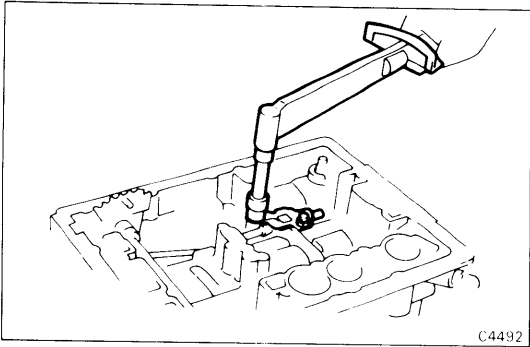

- (b) Install the parking lock pawl bracket with the two bolts.
Torque: 75 kg-cm (65 in.-lb, 7.4 N·m)
 - (c) Check that the pawl moves smoothly.
- NOTE:** It is possible for the bracket to be installed too far forward, where it will bind the pawl.

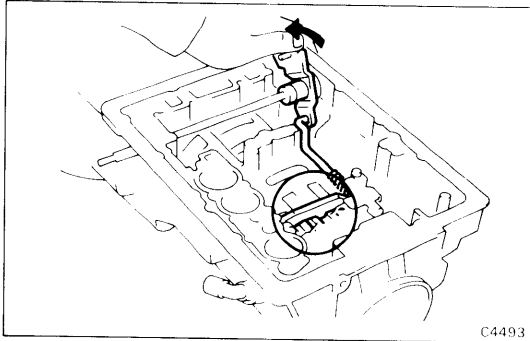

34. CHECK OPERATION OF PARKING LOCK PAWL

Make sure the planetary gear output shaft is locked when the manual valve lever is in "P" range.

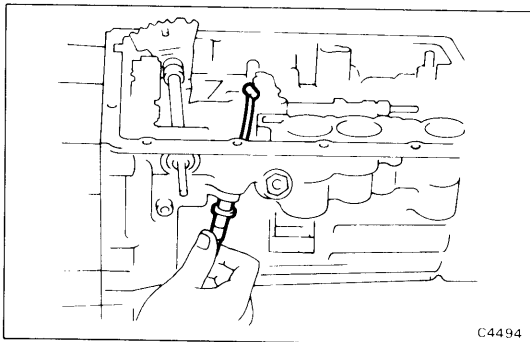

35. INSTALL NEW O-RING ON THROTTLE CABLE FITTING

36. INSTALL THROTTLE CABLE IN CASE

Push the cable through the case, being careful not to damage the O-ring. Check for full seating.

CAUTION: In subsequent work, do not roll the case over the cable and possibly break the cable fitting.

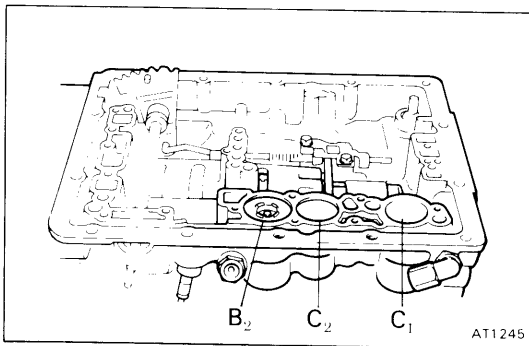

37. INSTALL ACCUMULATOR PISTON AND SPRINGS

mm (in.)

Spring	Free length	Outer diameter	No.	Wire diameter	Color
B ₂	55.18 (2.1724)	18.32 (0.7213)	11.0	2.6 (0.102)	Light green
	35.13 (1.3831)	16.16 (0.6362)	6.0	1.3 (0.051)	Red
C ₂	59.82 (2.3551)	16.57 (0.6524)	12.5	2.7 (0.106)	Green
C ₁	64.68 (2.5465)	17.50 (0.6890)	18.5	2.0 (0.079)	None

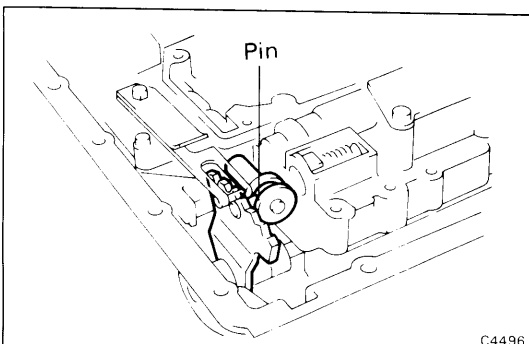

38. PLACE VALVE BODY ON TRANSMISSION

Make sure the accumulator pistons are pressed fully into the bore. Align the manual valve with the pin on the manual valve lever, and lower the valve body into place.

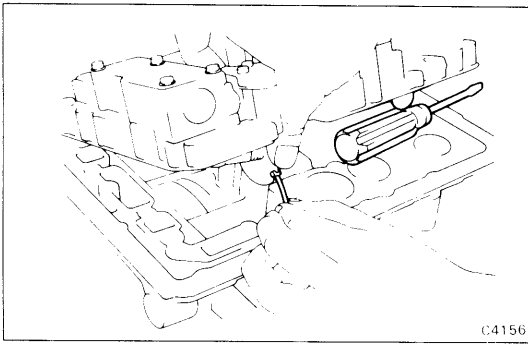

39. LIFT SIDE OF VALVE BODY AND ATTACH THROTTLE CABLE

While holding the cam down by hand, slip the cable end into the slot.

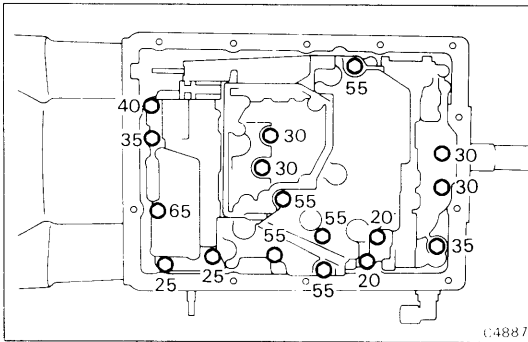

40. INSTALL BOLTS IN VALVE BODY

Install the bolts as shown.

NOTE: Each bolt length (mm) is indicated in the figure.

Torque: 100 kg-cm (7 ft-lb, 10 N·m)

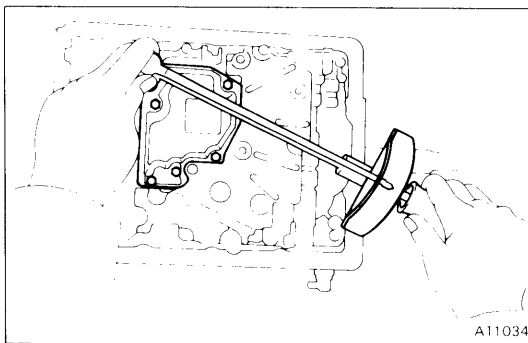

41. INSTALL OIL STRAINER

Install the small plate and oil strainer

Torque: 55 kg-cm (48 in.-lb, 5.4 N·m)

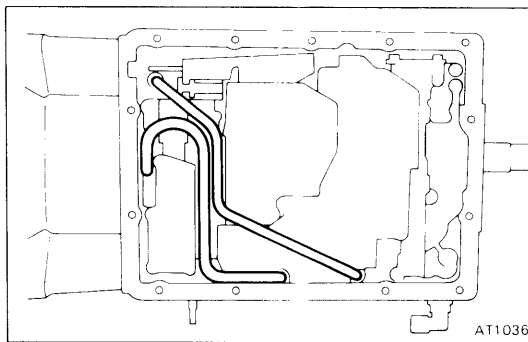

42. INSTALL OIL TUBES

Using a plastic-faced hammer, install the tubes into the position indicated in the photo.

CAUTION: Be careful not to bend or damage the tubes.

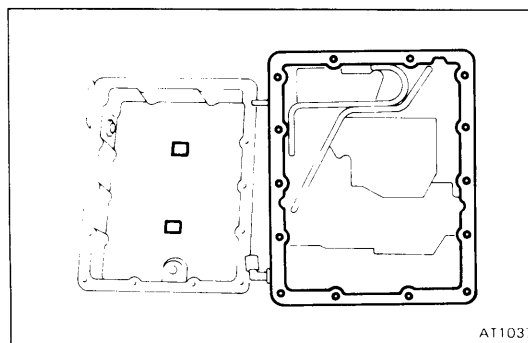

43. PLACE MAGNETS IN PAN AND INSTALL OIL PAN WITH NEW GASKET

(a) Install the magnets in the pan.

CAUTION: Make sure that the magnets do not interfere with the oil tubes.

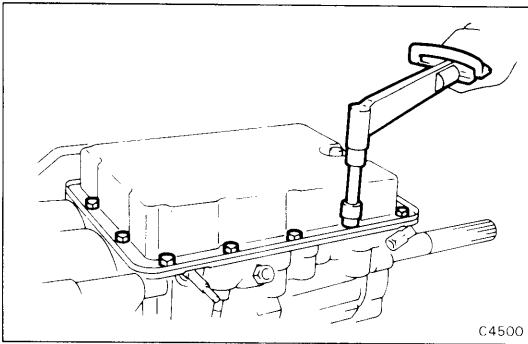

C4500

(b) Align the cut part of the gasket and case.

Torque: 45 kg-cm (39 in.-lb, 4.4 N·m)

44. INSTALL DRAIN PLUG WITH NEW GASKET

Torque: 175 kg-cm (13 ft-lb, 17 N·m)

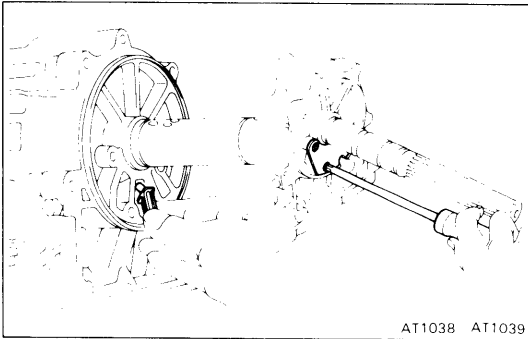

AT1038 AT1039

46. INSTALL GOVERNOR LINE STRAINER

(a) Install the strainer onto the case.

(b) Install the plate.

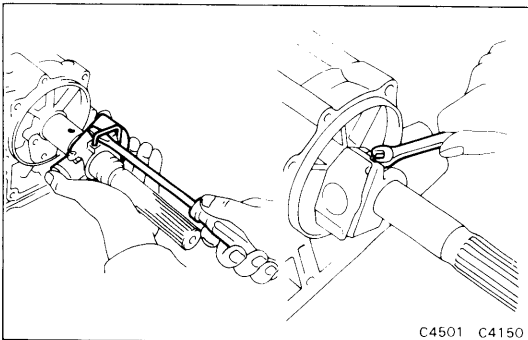

C4501 C4150

46. INSTALL GOVERNOR BODY ON OUTPUT SHAFT

(a) While lifting the retaining clip with a large screwdriver, slide the governor body and insert the retaining clip end into the hole on the output shaft.

(b) Install the lock plate and bolt, and then stake the lock plate.

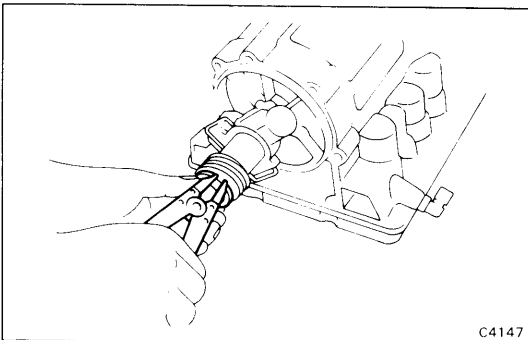

C4147

47. [2WD] INSTALL SPEEDOMETER DRIVE GEAR

(a) Install the snap ring and lock ball.

(b) Slide the speedometer gear on the shaft.

(c) Using snap ring pliers, install the outer snap ring.

48. [2WD] INSTALL REAR EXTENSION HOUSING WITH NEW GASKET

(a) Clean the threads of the A bolt and bolt hole with white gasoline.

(b) Coat the threads of the A bolt with sealer.

Sealer: Part No. 08833-00080, THREE BOND 1344, LOCTITE 242 or equivalent

(c) Install the extension housing over a new gasket with bolts, and then torque them.

NOTE: The two lower bolts are shorter.

Torque: 345 kg-cm (25 ft-lb, 34 N·m)

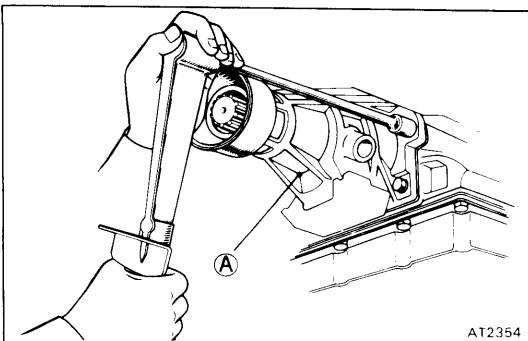

AT2354

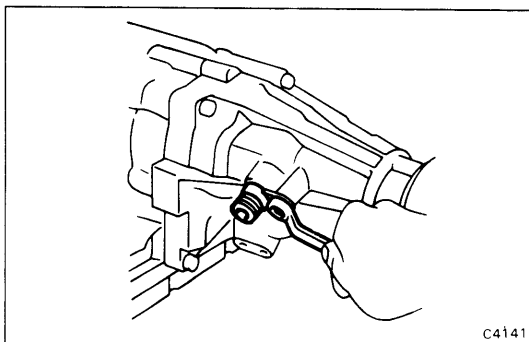

49. [2WD]
INSTALL O-RINGS, BUSHING AND SPEEDOMETER DRIVEN GEAR TO SHAFT SLEEVE

50. [2WD]
INSTALL SPEEDOMETER DRIVEN GEAR ASSEMBLY IN EXTENSION HOUSING

Insert the shaft sleeve assembly into the housing. Install the lock plate with a bolt and lock washer.

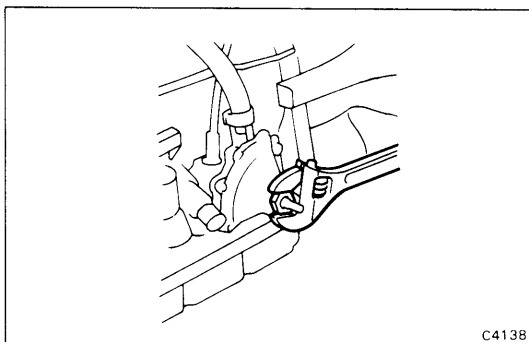

51. INSTALL NEUTRAL START SWITCH

- Slide the neutral start switch onto the control shaft.
- Install the grommet, facing the groove toward the switch body, and then install the washer and nut.

Torque: 70 kg-cm (61 in.-lb, 6.9 N·m)

52. INSTALL SHIFT HANDLE

53. ADJUST NEUTRAL START SWITCH
(See page AT-4)

Torque: 55 kg-cm (48 in.-lb, 5.4 N·m)

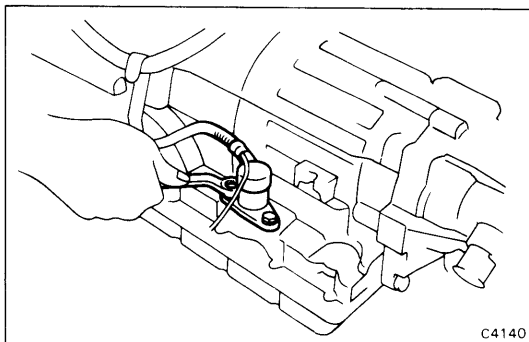

54. INSTALL SOLENOID

Install the solenoid on the body with two O-rings.

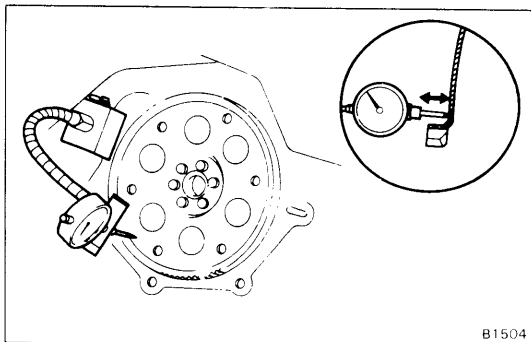

INSTALLATION OF TRANSMISSION (2WD)

1. MEASURE DRIVE PLATE RUNOUT AND INSPECT RING GEAR

Set up a dial indicator and measure the drive plate runout. If runout exceeds 0.20 mm (0.0079 in.) or if the ring gear is damaged, replace the drive plate. If installing a new drive plate, note the orientation of the spacers and tighten the bolts.

Torque: 750 kg-cm (54 ft-lb, 74 N·m)

Runout: 0.20 mm (0.0079 in.) or less

2. MEASURE TORQUE CONVERTER SLEEVE RUNOUT

(a) Temporarily mount the torque converter to the drive plate. Set up a dial indicator.

If runout exceeds 0.30 mm (0.0118 in.), try to correct it by reorienting the installation of the converter. If excessive runout cannot be corrected, replace the torque converter.

Runout: 0.30 mm (0.0118 in.) or less

NOTE: Mark the position of the converter to ensure correct installation.

(b) Remove the torque converter.

3. INSTALL TRANSMISSION MOUNTING ON EXTENSION HOUSING

Inspect the rubber mounting for deterioration and replace it if necessary.

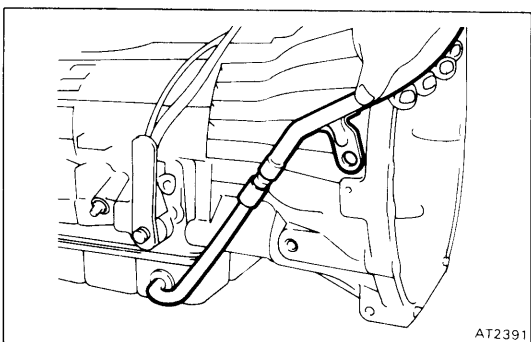
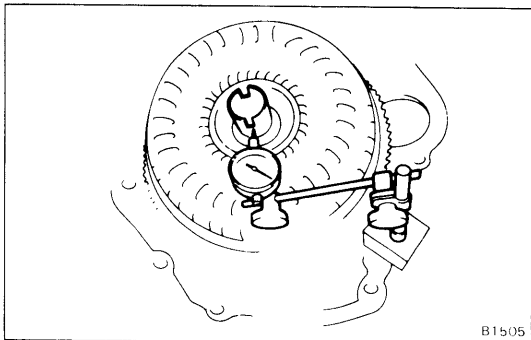

4. INSTALL FILLER TUBE

Replace the O-ring and push the tube into place.

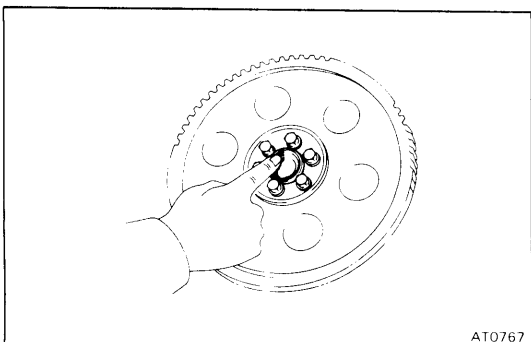

5. APPLY GREASE TO CENTER HUB OF TORQUE CONVERTER AND PILOT HOLE IN DRIVE PLATE

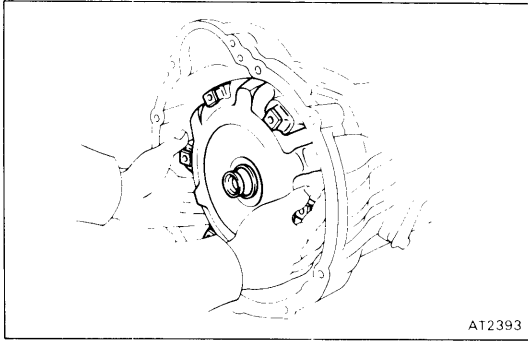

6. INSTALL TORQUE CONVERTER IN TRANSMISSION

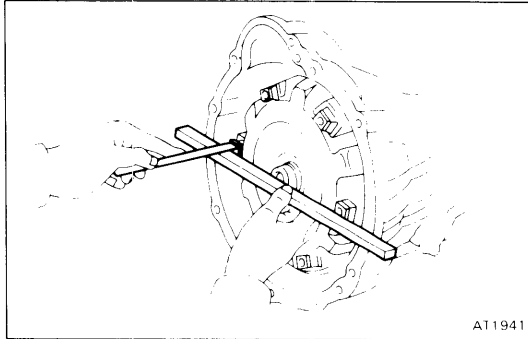

7. CHECK TORQUE CONVERTER INSTALLATION

Using calipers and a straight edge, measure from the installed surface to the front surface of the transmission housing.

Correct distance: 26 mm (1.02 in.)

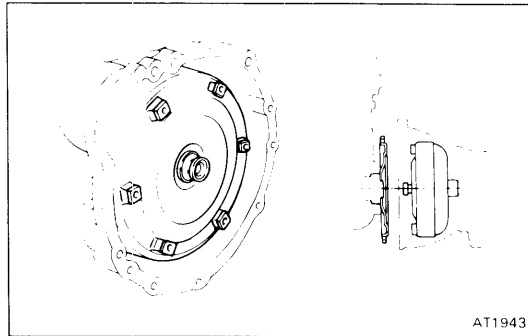

8. ALIGN TRANSMISSION AT INSTALLATION POSITION

CAUTION: Be careful not to tilt the transmission forward because the torque converter could slide out.

Align the two sleeves on the block with the converter housing.

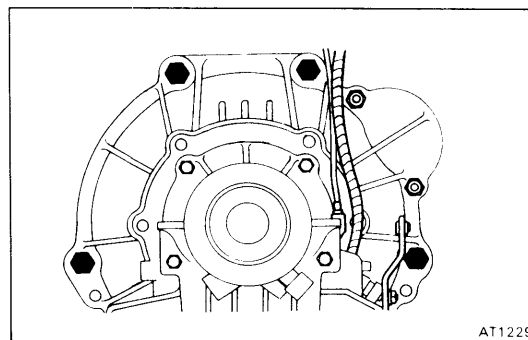

9. INSTALL BOLTS IN CONVERTER HOUSING

Install the filler tube bracket with the upper right-hand bolt and tighten bolts.

Torque: 650 kg-cm (47 ft-lb, 64 N·m)

10. INSTALL STARTER

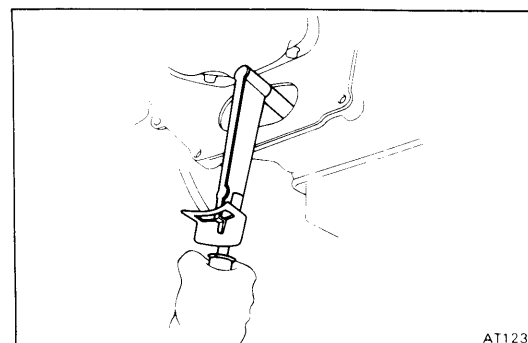

11. INSTALL SIX TORQUE CONVERTER BOLTS

- Align the drive plate and converter holes.
- First install the gray bolt, then other bolts. Turn the crankshaft to gain access.
- Tighten the bolts evenly.

Torque: 280 kg-cm (20 ft-lb, 27 N·m)

12. INSTALL SERVICE HOLE COVER AT REAR OF ENGINE

13. INSTALL ENGINE UNDER COVER

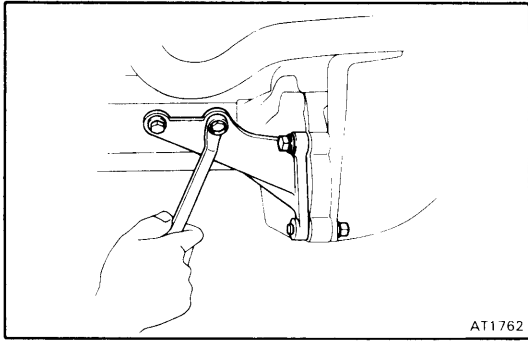
**14. INSTALL BOTH STIFFNER PLATES**

Torque: 375 kg-cm (27 ft-lb, 37 N·m)

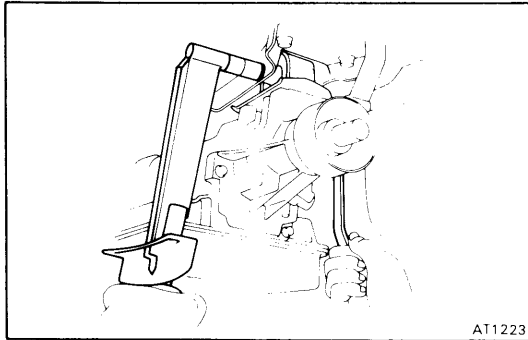
**15. INSTALL TRANSMISSION MOUNTING THROUGH BOLT**

Torque: 500 kg-cm (36 ft-lb, 49 N·m)

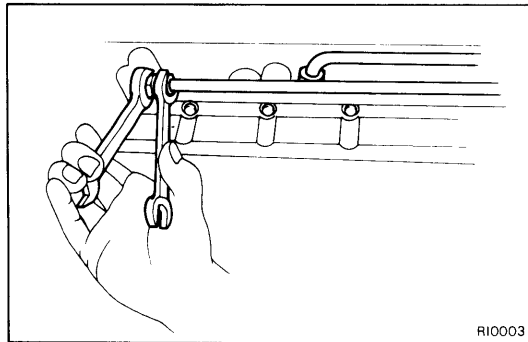
**16. CONNECT TWO OIL COOLER LINES**

Torque: 350 kg-cm (25 ft-lb, 34 N·m)

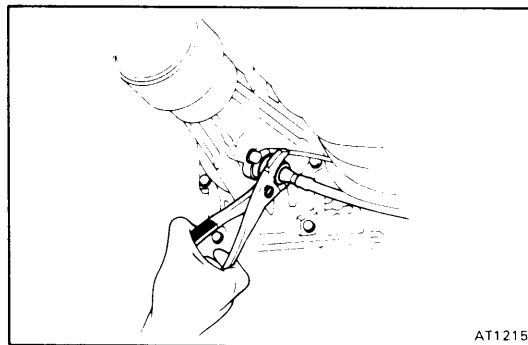
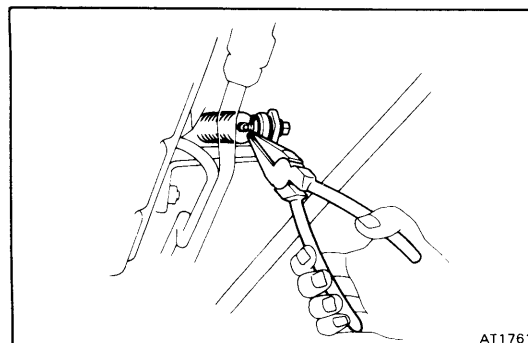
17. INSTALL TWO COOLER LINE CLAMPS**18. CONNECT SPEEDOMETER CABLE AND BOND CABLE****19. CONNECT SHIFT CABLE TO TRANSMISSION**
(See page AT-4)**20. INSTALL EXHAUST PIPE CLAMP**

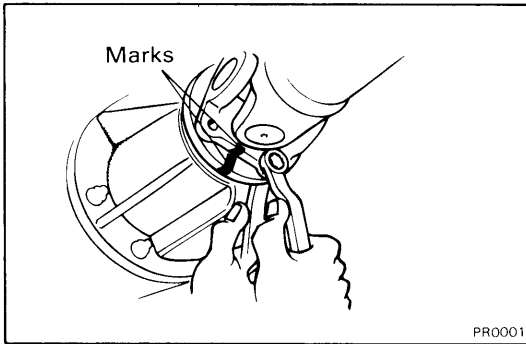

21. INSTALL PROPELLER SHAFT

Torque: 430 kg-cm (31 ft-lb, 42 N·m)

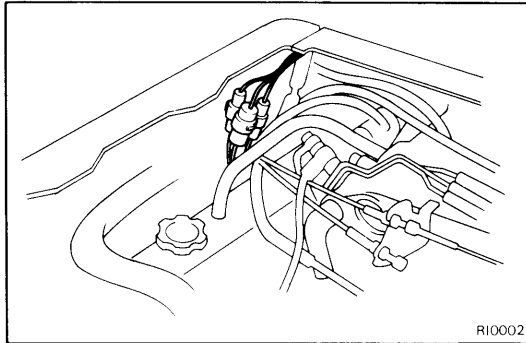

22. LOWER VEHICLE AND CONNECT WIRING CONNECTORS

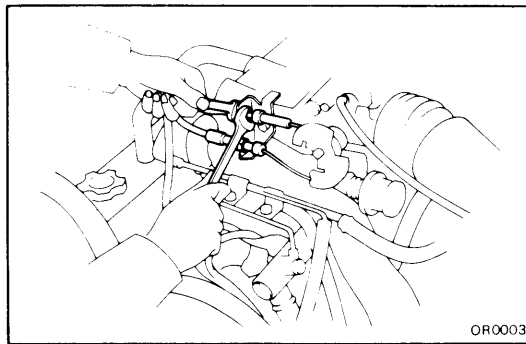

23. CONNECT AND ADJUST TRANSMISSION THROTTLE CABLE

- (a) Connect the cable to the throttle linkage.
- (b) Connect the cable housing to the bracket.
- (c) Adjust the transmission throttle cable.
(See page AT-4)

24. CONNECT BATTERY CABLE TO NEGATIVE (-) TERMINAL

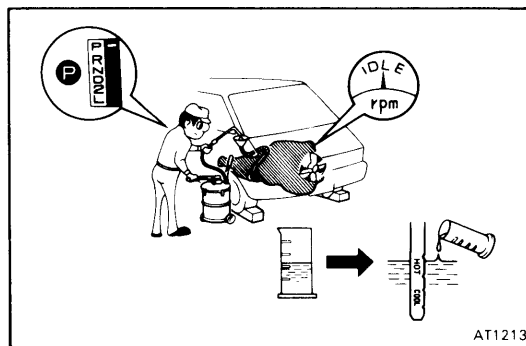

25. FILL TRANSMISSION WITH ATF

Fluid type: ATF DEXRON® II

Total capacity: 6.5 liters (6.9 US qts, 5.7 Imp. qts)

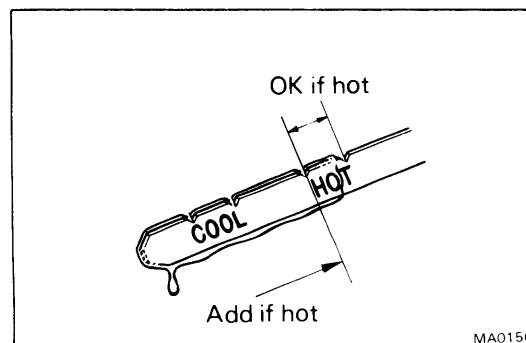

26. CHECK FLUID LEVEL (See page MA-15)

27. ROAD TEST VEHICLE

Check for abnormal noise, shock, slippage, correct shift points and smooth operation.

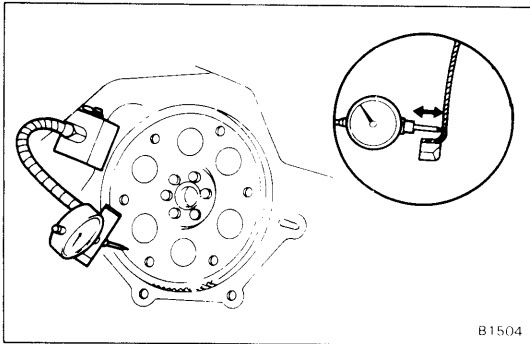

B1504

INSTALLATION OF TRANSMISSION (4WD)

1. MEASURE DRIVE PLATE RUNOUT AND INSPECT RING GEAR

Set up a dial indicator and measure the drive plate runout.

If runout exceeds 0.20 mm (0.0079 in.) or if the ring gear is damaged, replace the drive plate. If installing a new drive plate, note the orientation of the spacers and tighten the bolts.

Torque: 750 kg-cm (54 ft-lb, 74 N·m)

Runout: 0.20 mm (0.0079 in.) or less

2. MEASURE TORQUE CONVERTER SLEEVE RUNOUT

(a) Temporarily mount the torque converter to the drive plate. Set up a dial indicator.

If runout exceeds 0.30 mm (0.0118 in.), try to correct it by reorienting the installation of the converter. If excessive runout cannot be corrected, replace the torque converter.

Runout: 0.30 mm (0.0118 in.) or less

NOTE: Mark the position of the converter to ensure correct installation.

(b) Remove the torque converter.

3. INSTALL TRANSMISSION MOUNTING ON TRANSFER ADAPTOR

Inspect rubber mounting for deterioration and replace if necessary.

4. INSTALL FILLER TUBE

Replace the O-ring and push the tube into place.

5. INSTALL TRANSFER WITH NEW GASKET

(a) Install the transfer to the transmission with a new gasket.

(b) Apply seal packing to the two front bolts.

Seal packing: Part No. 08833-00080, THREE BOND 1344, LOCTITE 242 or equivalent

(c) Install and torque the bolts.

Torque: 380 kg-cm (27 ft-lb, 37 N·m)

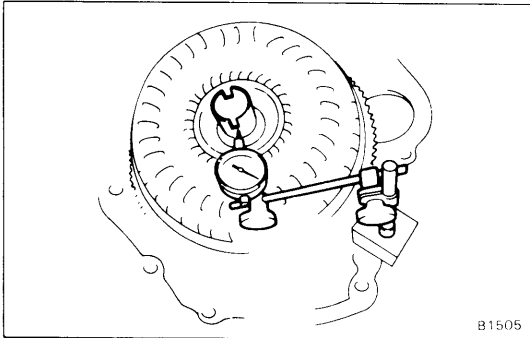

B1505

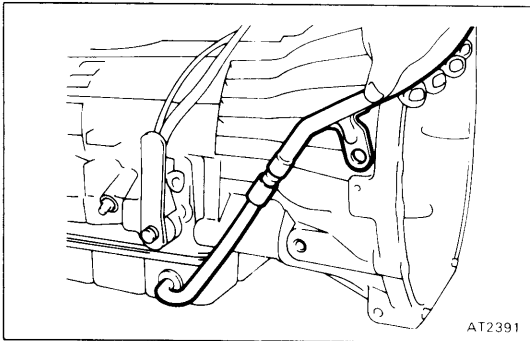

AT2391

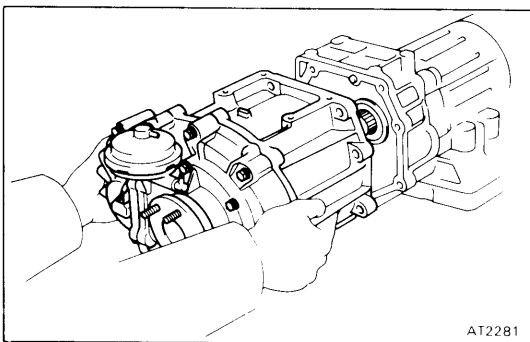

AT2281

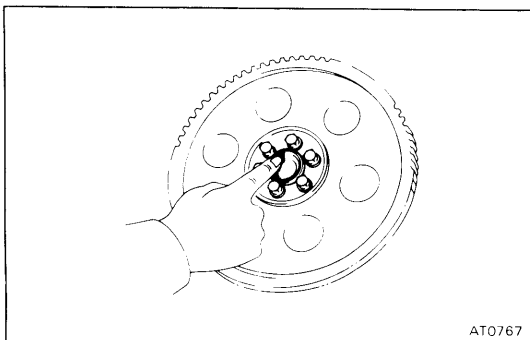

AT0767

6. APPLY GREASE TO CENTER HUB OF TORQUE CONVERTER AND PILOT HOLE IN DRIVE PLATE

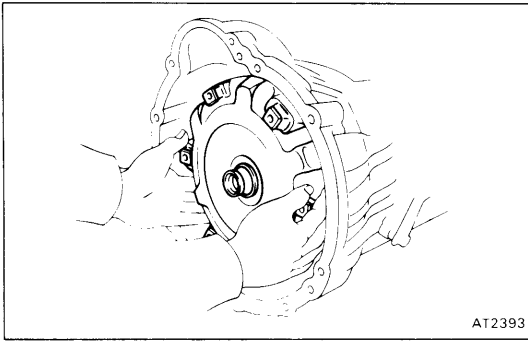

AT2393

7. INSTALL TORQUE CONVERTER IN TRANSMISSION

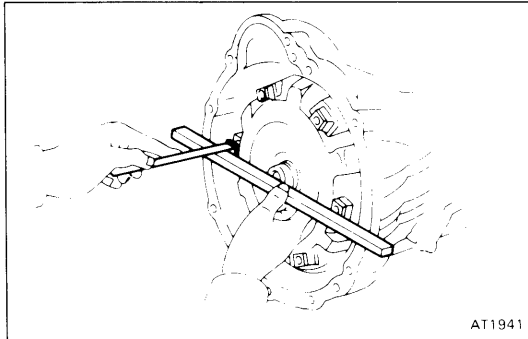

AT1941

8. CHECK TORQUE CONVERTER INSTALLATION

Using scale and straight edge, measure from the installed surface to the front surface of the transmission housing.

Correct distance: 27.1 mm (1.067 in.)

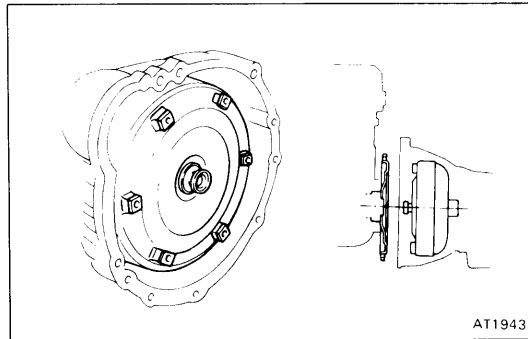

AT1943

9. ALIGN TRANSMISSION AT INSTALLATION POSITION

CAUTION: Be careful not to tilt the transmission forward because the torque converter could slide out.

Align the two sleeves on the block with the converter housing.

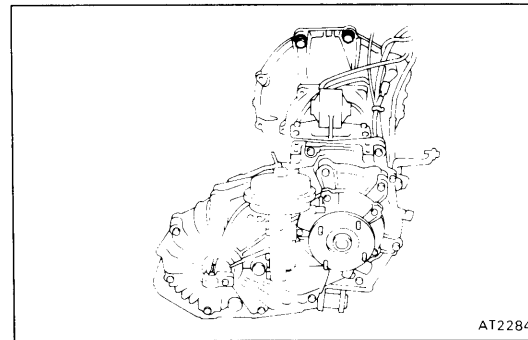

AT2284

10. INSTALL BOLTS IN TRANSMISSION HOUSING

Torque: 650 kg-cm (47 ft-lb, 64 N·m)

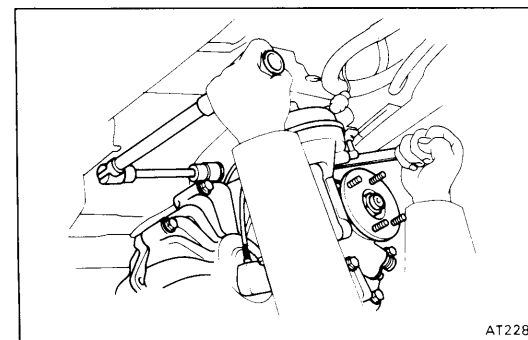

AT2286

11. INSTALL TRANSMISSION MOUNTING THROUGH BOLT

Torque: 500 kg-cm (36 ft-lb, 49 N·m)

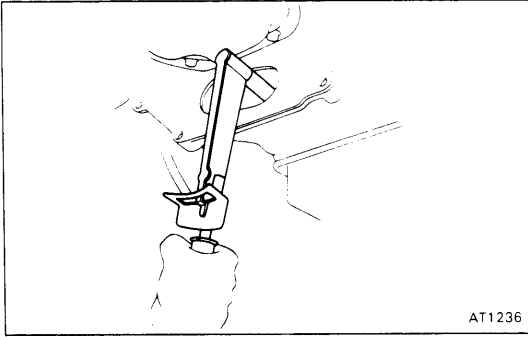
**12. INSTALL TORQUE CONVERTER BOLTS**

- (a) Align the drive plate and converter holes.
- (b) First install the gray bolt, then other bolts. Turn the crankshaft to gain access.
- (c) Tighten the six bolts evenly.

Torque: 280 kg-cm (20 ft-lb, 27 N·m)

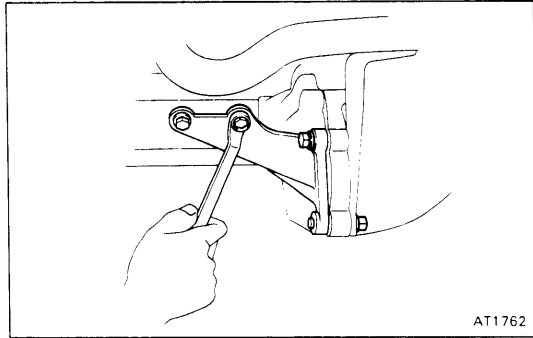
13. INSTALL SERVICE HOLE COVER**14. INSTALL BOTH STIFFENER PLATES**

Torque: 375 kg-cm (27 ft-lb, 37 N·m)

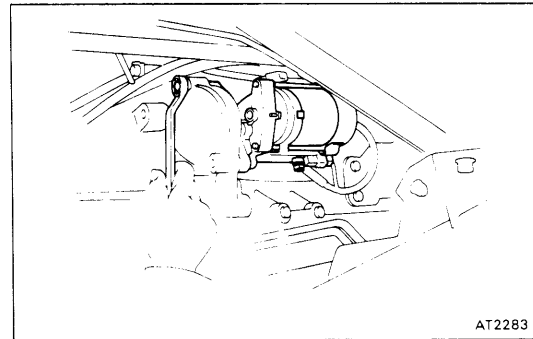
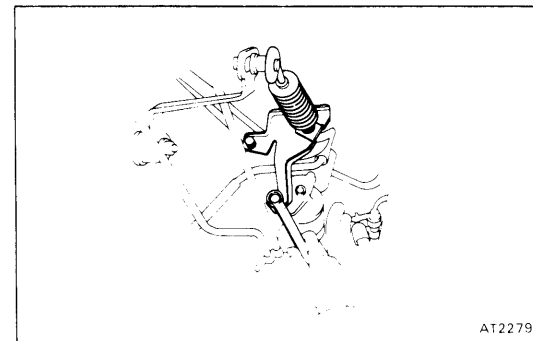
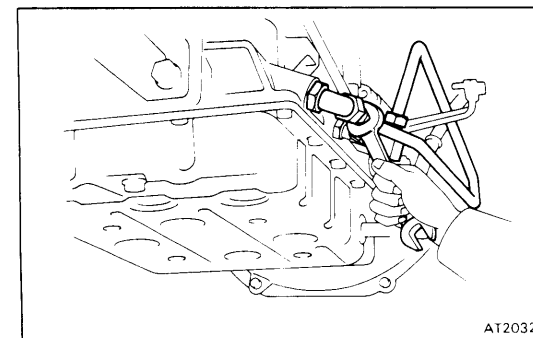
**15. INSTALL STARTER****16. INSTALL CONTROL CABLE BRACKET****17. CONNECT OIL COOLER LINES**

Torque: 350 kg-cm (25 ft-lb, 34 N·m)

18. INSTALL COOLER LINE CLAMPS

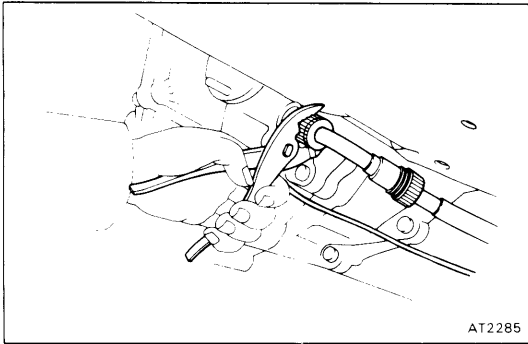

- 19. CONNECT SPEEDOMETER CABLE, GROUND STRAP AND TRANSFER INDICATOR SWITCH CONNECTOR**

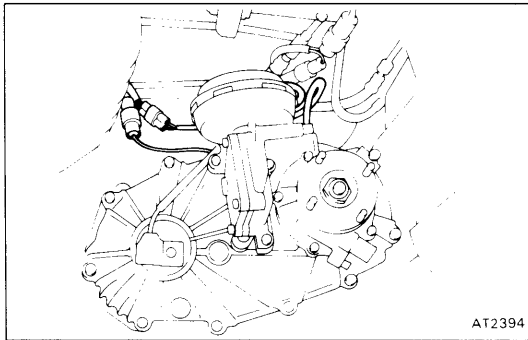

- 20. CONNECT SPEED SENSOR AND 4WD INDICATOR CONNECTOR**

- 21. CONNECT VACUUM HOSES TO VACUUM ACTUATOR**

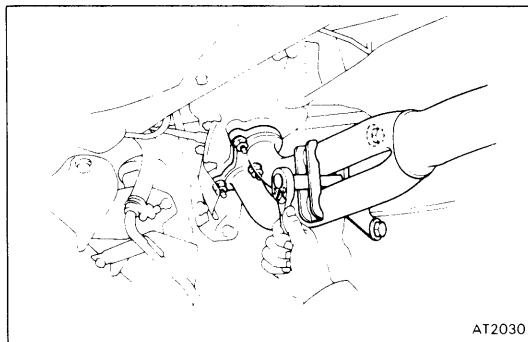

- 22. CONNECT EXHAUST PIPE TO MANIFOLD**

(a) Connect the exhaust pipe to the manifold.

Torque: 630 kg-cm (46 ft-lb, 62 N·m)

(b) Install the exhaust pipe clamp.

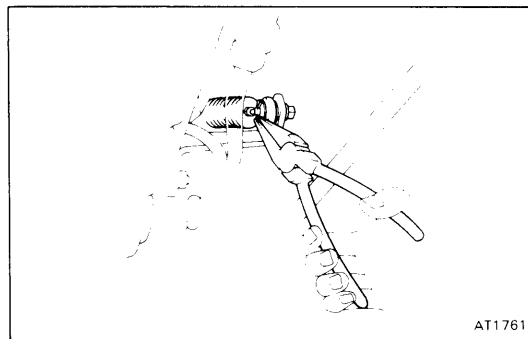

- 23. CONNECT TRANSMISSION SHIFT CABLE TO SHIFT LEVER**

- 24. CONNECT ATF THERMO SENSOR CONNECTOR**

- 25. INSTALL FRONT AND REAR PROPELLER SHAFTS**
(See page PR-4)

- 26. FILL TRANSFER WITH OIL**

Oil type: **API GL-4 or GL-5**

Viscosity: **SAE 75W-90**

Capacity: **1.2 liters (1.3 US qts, 1.1 Imp.qts)**

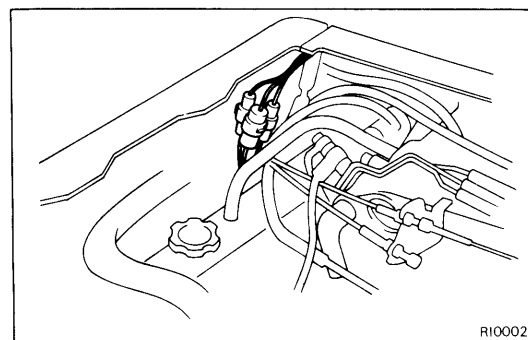

- 27. LOWER VEHICLE AND CONNECT WIRING CONNECTORS**

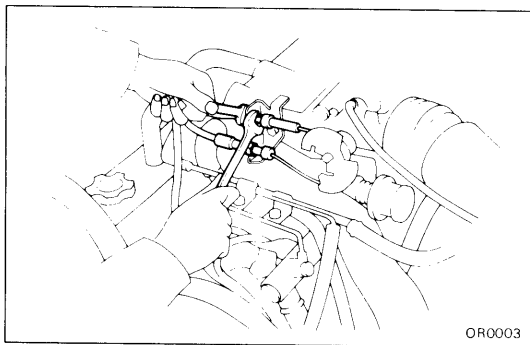

28. CONNECT AND ADJUST TRANSMISSION THROTTLE CABLE

- Connect the cable to the throttle linkage.
- Connect the cable housing to the bracket.

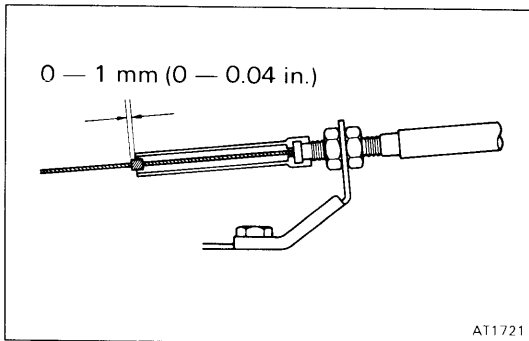

- Adjust the transmission throttle cable.

29. CONNECT BATTERY CABLE TO NEGATIVE (–) TERMINAL

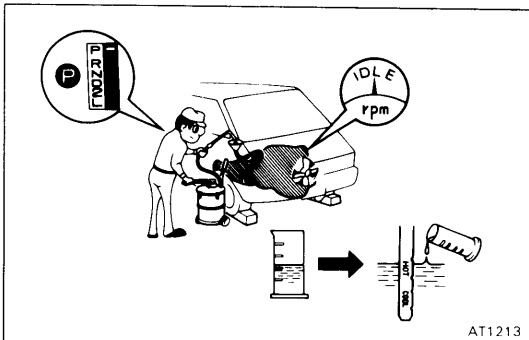

30. FILL TRANSMISSION WITH ATF

Fluid type: ATF DEXRON® II

Total capacity: 6.5 liters (6.9 US qts, 5.7 Imp. qts)

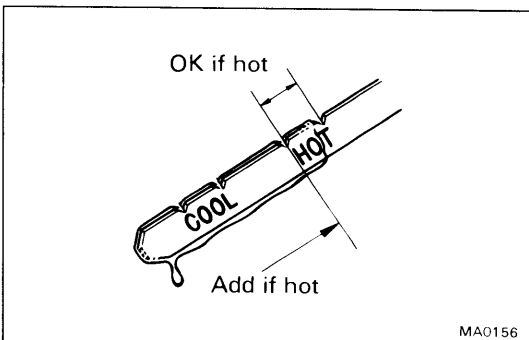

31. CHECK FLUID LEVEL (See page MA-15)

32. ROAD TEST VEHICLE

Check for abnormal noise, shock, slippage, correct shift points and smooth operation.