

STEERING

	Page
CUTAWAY VIEW	8-2
INTERMEDIATE SHAFT	8-4
TILT TYPE STEERING COLUMN & MAIN SHAFT	8-15
STEERING COLUMN & MAIN SHAFT	8-42
STEERING GEAR HOUSING	8-55
STEERING LINKAGE	8-88
POWER STEERING	8-102

CUTAWAY VIEW

Fig. 8-1

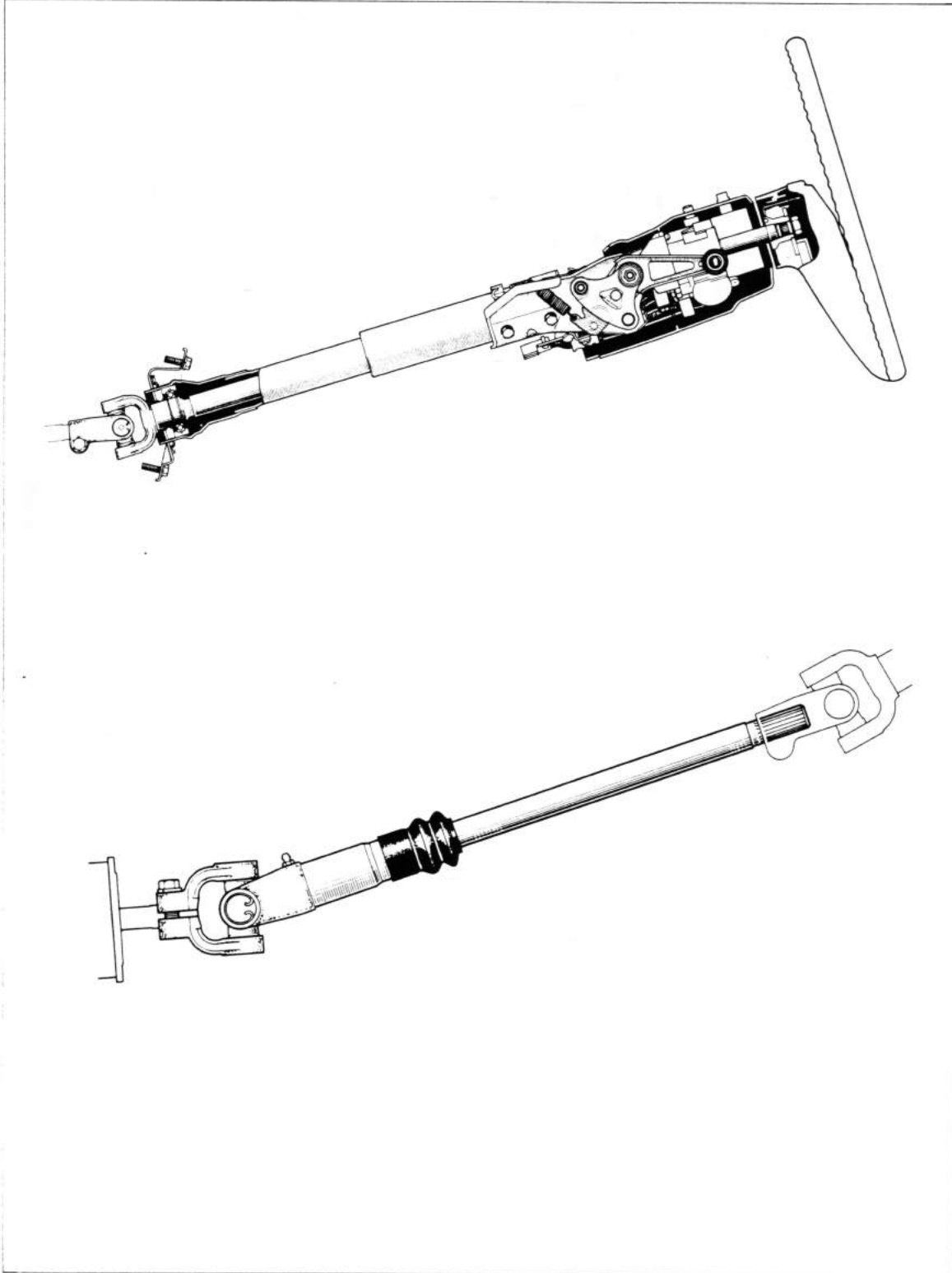
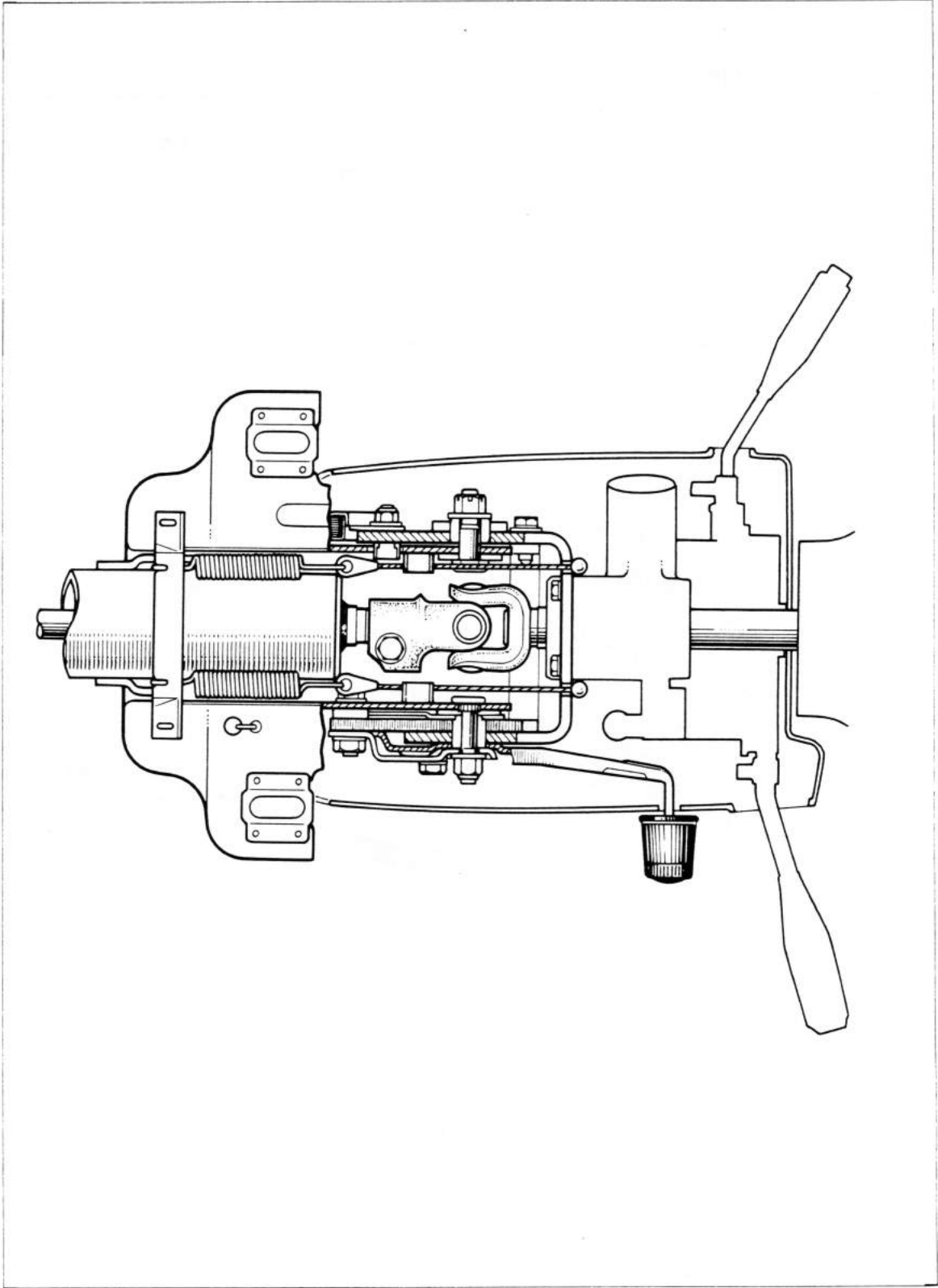

Fig. 8-2



INTERMEDIATE SHAFT

REMOVAL

Remove the parts in the numerical order shown in the figure.

Fig. 8-3

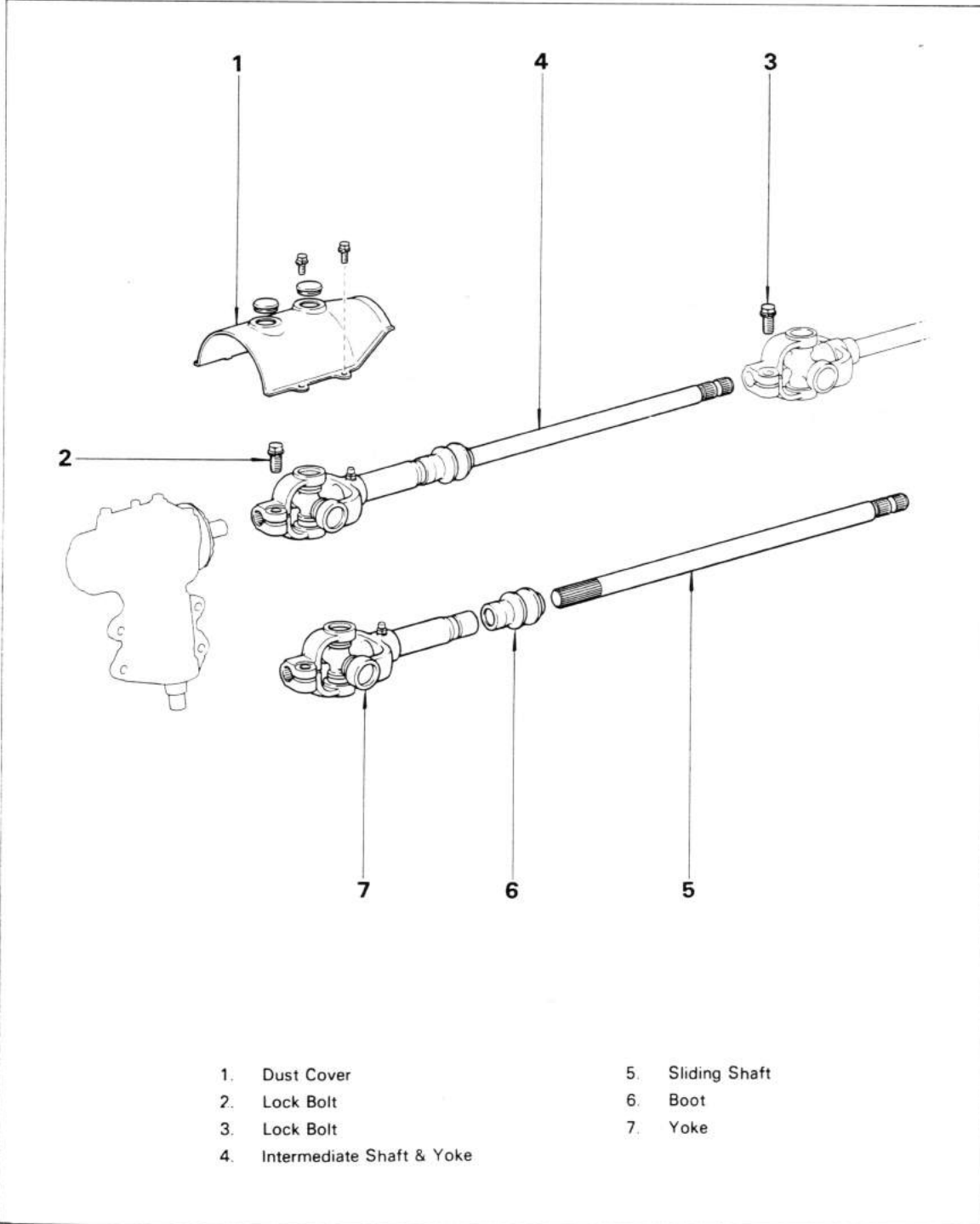
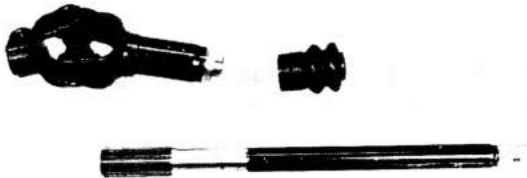

Fig. 8-4



INSPECTION & REPAIR



Shaft

Check for wear, bending or damage.

Fig. 8-5

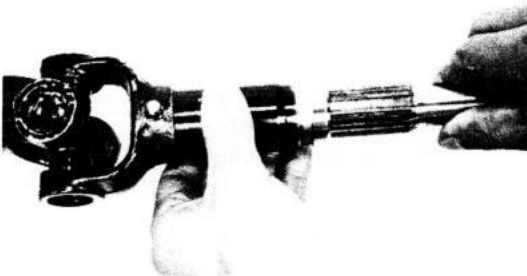

Spline

Check for wear or damage.

Fig. 8-6

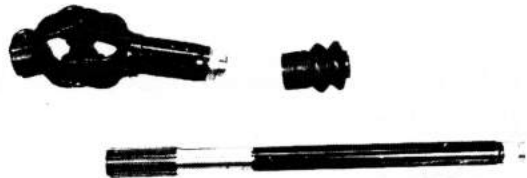

Boot

Check for damage.

Fig. 8-7



Spider Bearing

Check for wear or damage.

Fig. 8-8

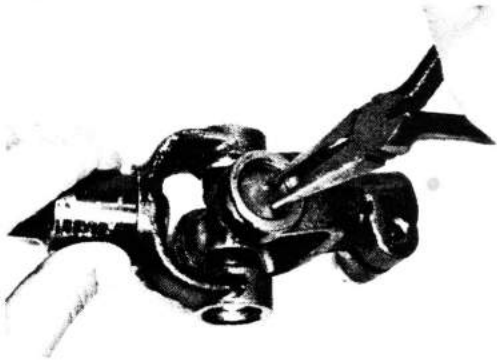
**Replace The Spider Bearing**

1. Remove the snap rings.

Fig. 8-9

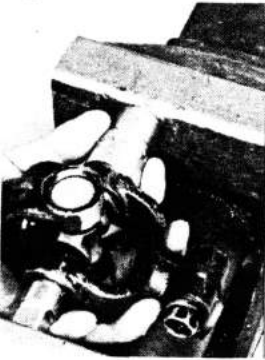

2. Remove the bearing outer race with a vice and socket wrench.
3. Tap out the bearing outer race.

Fig. 8-10



4. Remove the bearing outer race on the opposite side.

— Note —

Remove the shaft side bearings by the same procedure.

Fig. 8-11



5. Apply MP grease to the new bearings

Fig. 8-12

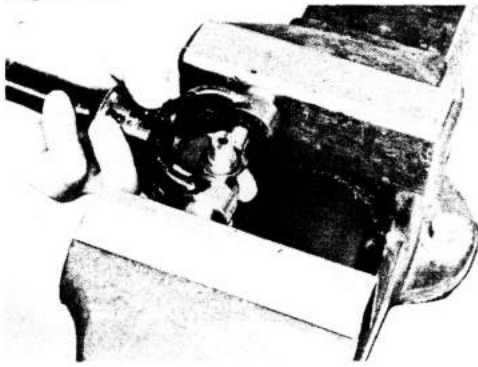

6. Push in the bearing outer races on both sides until the surfaces.

Fig. 8-13

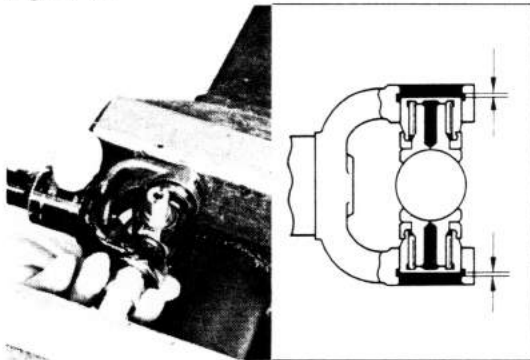

7. Push in the bearing outer race until the spider is moved.
8. Push in the bearing outer race on the opposite side until both snap ring grooves have equal clearance.

— Note —
Install the yoke side bearings by the same procedure.

Fig. 8-14

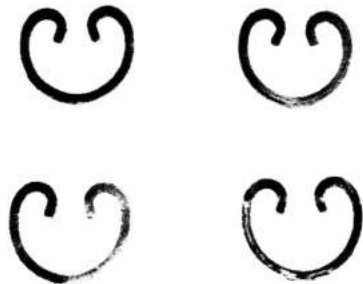

9. Select snap rings that will provide minimum play.

Spider axial play:

Less than 0.05 mm (0.0020 in.)

Snap ring thickness

Mark	Thickness	mm (in.)
None	1.175 – 1.225	(0.0463 – 0.0482)
Brown	1.225 – 1.275	(0.0482 – 0.0502)
Blue	1.275 – 1.325	(0.0502 – 0.0522)



— Note —

1. Do not reuse the snap rings.
2. Use the snap rings of the same thickness at both sides.

Fig. 8-15

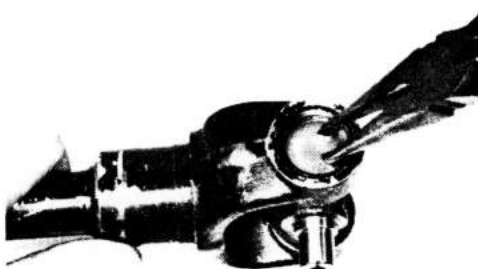

10. Install the snap rings.

Fig. 8-16



11. Check to see that spider moves smoothly.

ASSEMBLY & INSTALLATION

Assemble and Install the parts in the numerical order shown in the figure.

Fig. 8-17

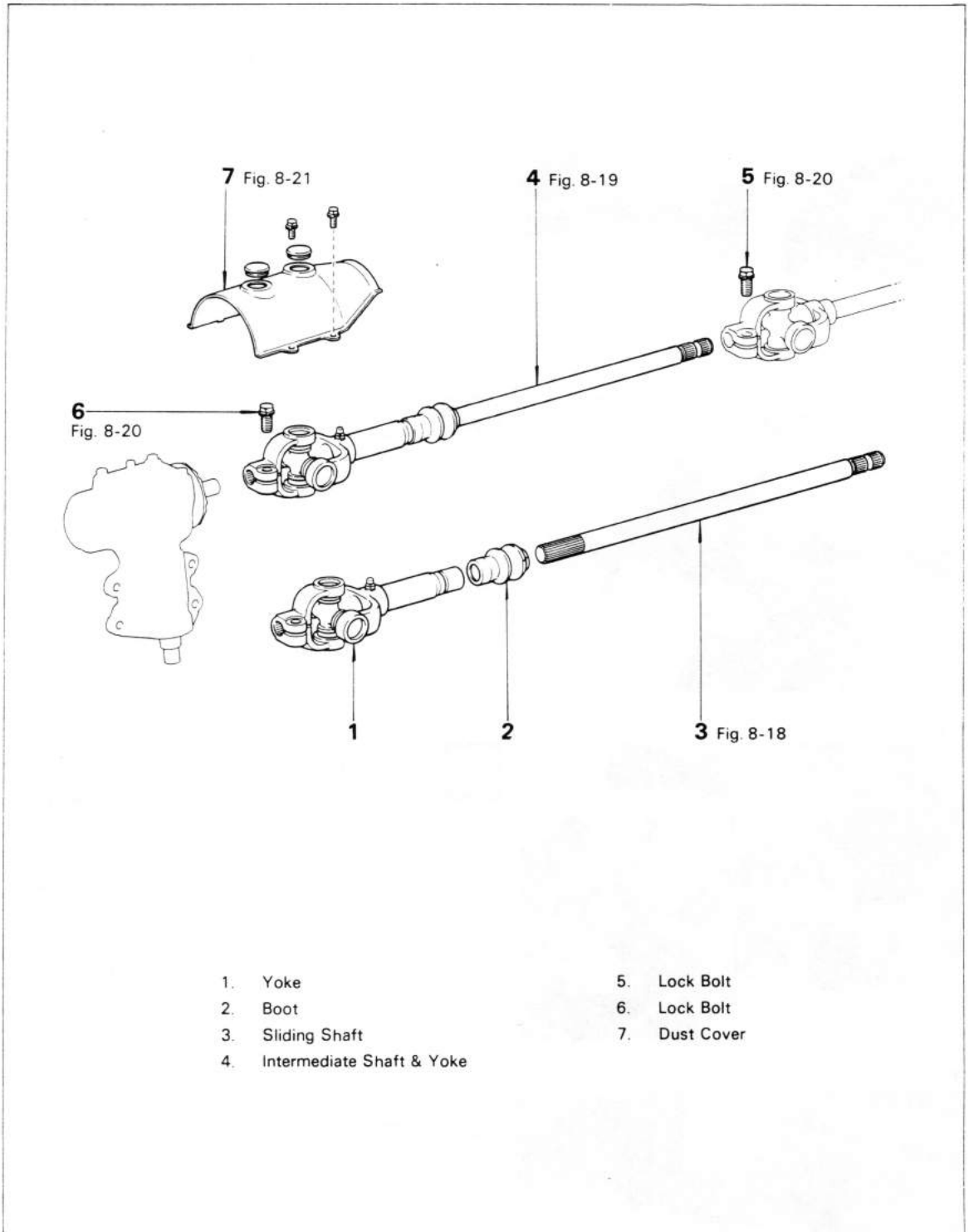

- 1. Yoke
- 2. Boot
- 3. Sliding Shaft
- 4. Intermediate Shaft & Yoke

- 5. Lock Bolt
- 6. Lock Bolt
- 7. Dust Cover

Fig. 8-18

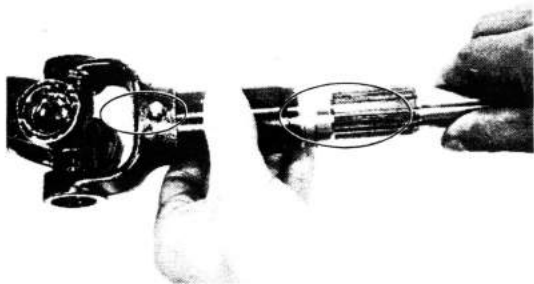

Align the grease nipple to the cut of spline tooth.

Fig. 8-19



Align the non-toothed portions of the intermediate shaft and joint yoke.

Fig. 8-20

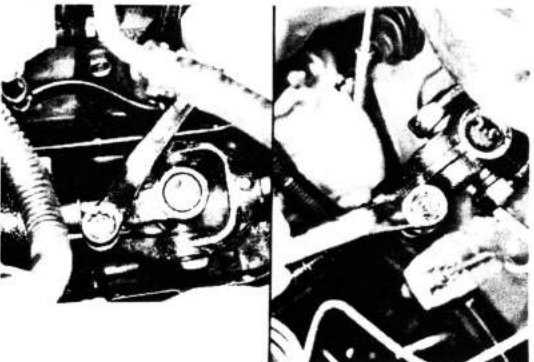

Tighten the bolt.

Tightening torque: 3.0 – 4.5 kg-m
(22 – 32 ft-lb)

Fig. 8-21

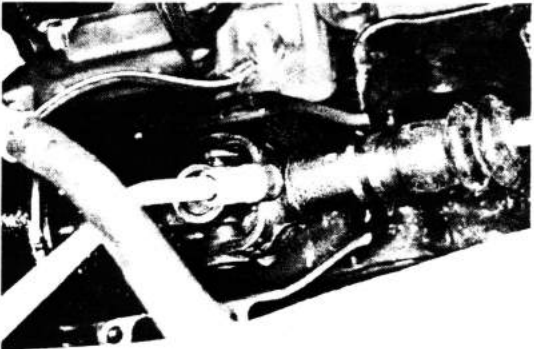

Before installing the dust cover, grease to the grease fitting.

DISASSEMBLY

Disassemble the parts in the numerical order shown in the figure.

Fig. 8-22

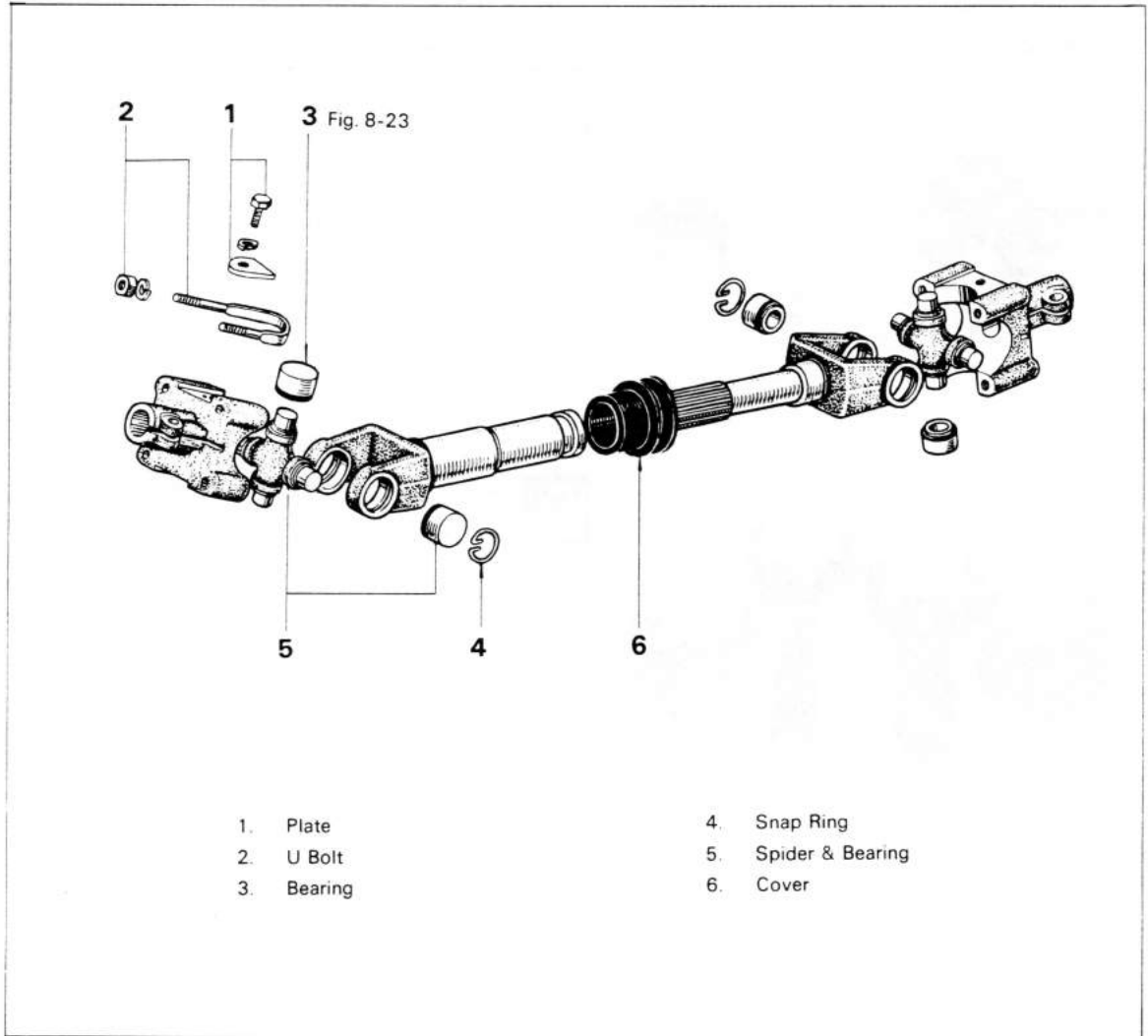

Fig. 8-23



Remove the bearing cup by lightly tapping the yoke with a hammer.

— Note —

Hold downward the bearing and spider at the other end while tapping the yoke.

Fig. 8-24

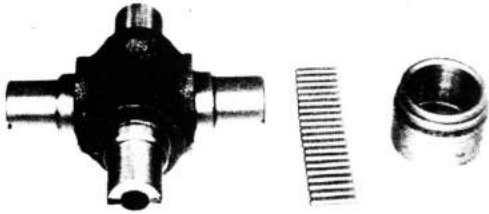

INSPECTION

Inspect the spider and bearing for wear or damage.

Fig. 8-25

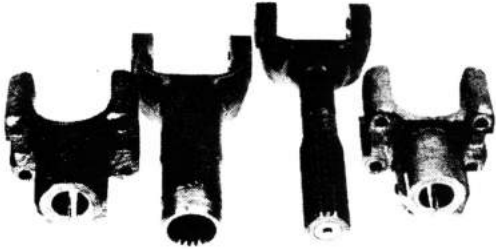

Inspect the splines for wear or damage.

ASSEMBLY

Assemble the parts in the numerical order shown in the figure.

Fig. 8-26

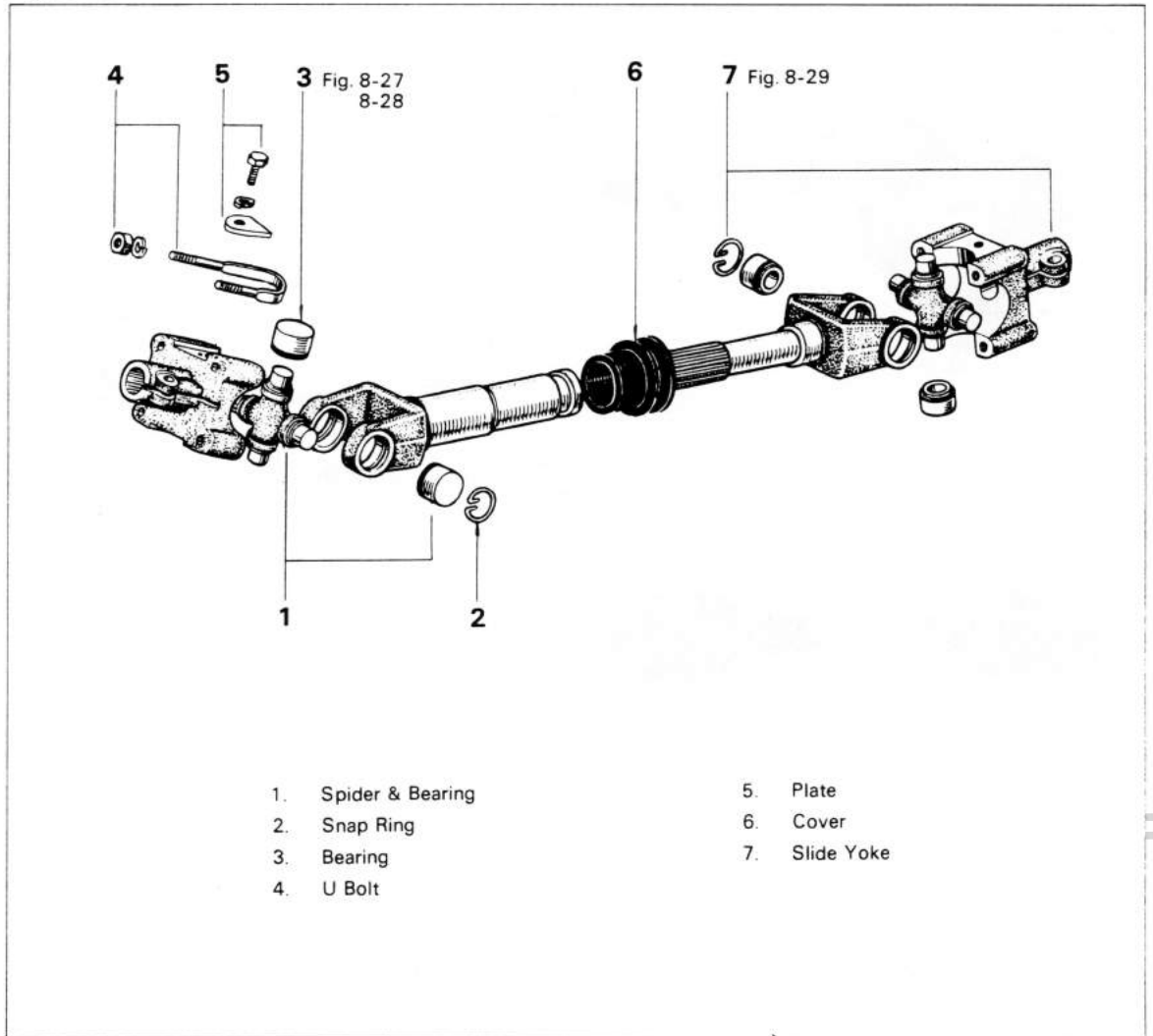
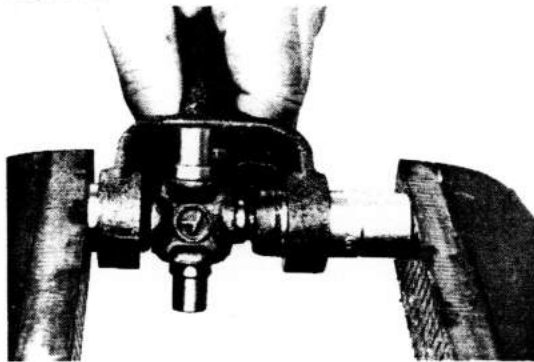
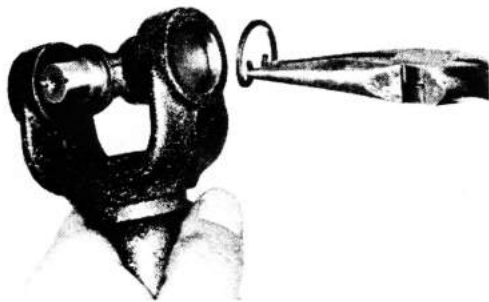

Fig. 8-27



Using a vise, assemble the bearings.

Fig. 8-28



Select snap rings of the thickness that will provide minimum thrust clearance in the joint spider but will still allow the joint spider to operate smoothly.

Snap ring thickness

Part No.	Thickness mm (in.)
90521-22011	1.20 (0.0472)
90521-22012	1.25 (0.0492)
90521-22013	1.30 (0.0512)

Fig. 8-29



Make the assembly so that the steering yokes will be positioned in the same direction.

TILT TYPE STEERING COLUMN & MAIN SHAFT

REMOVAL

Remove the parts in the numerical order shown in the figure.

Fig. 8-30

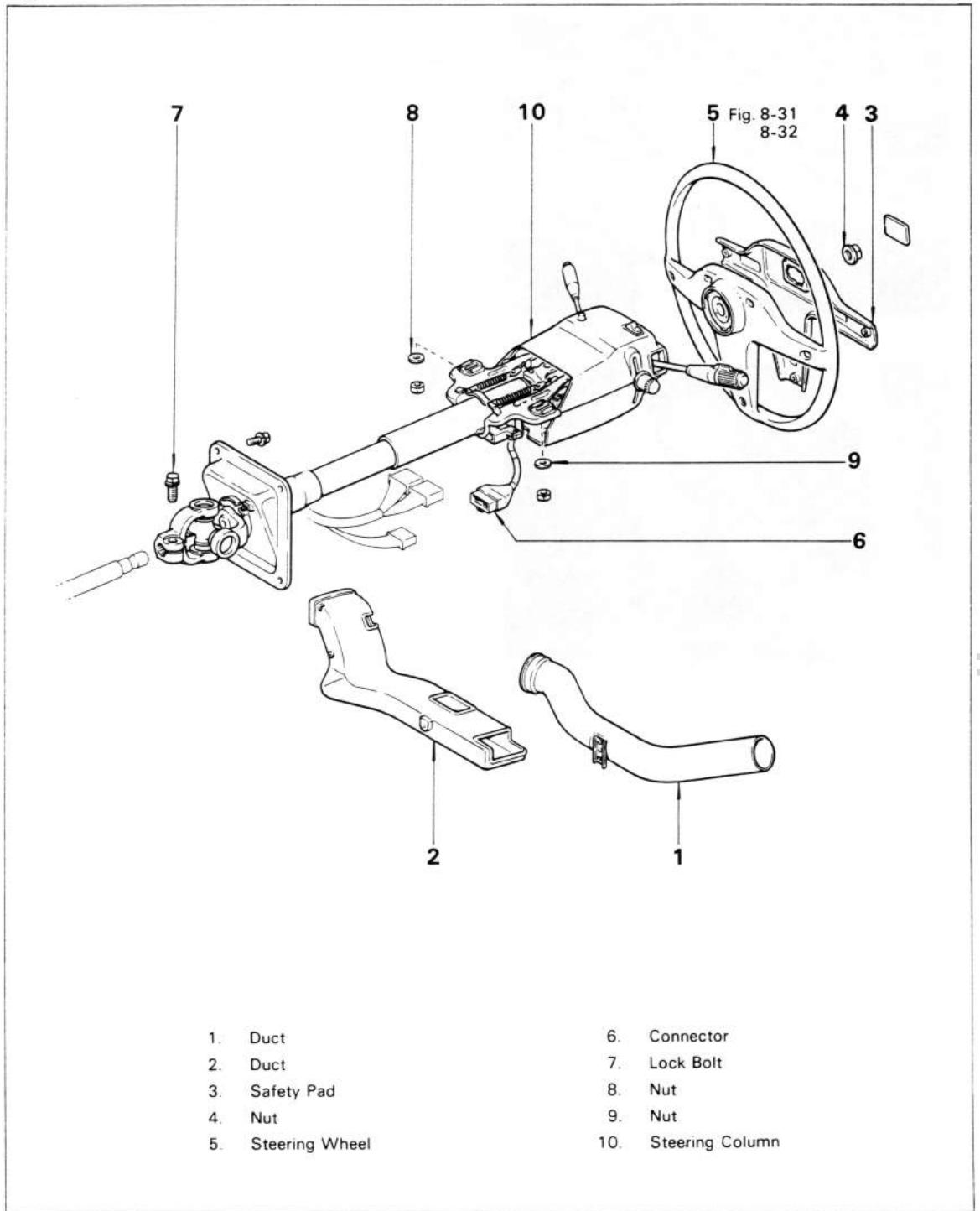
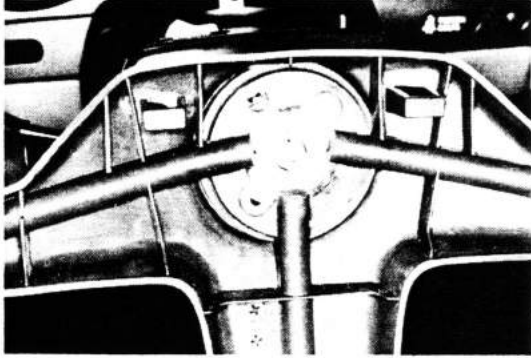

Fig. 8-31



Place matchmarks on the steering wheel and main shaft.

Fig. 8-32



Remove the steering wheel with SST.
SST [09609-20010]

DISASSEMBLY

1. Disassemble the parts in the numerical order shown in the figure.

Fig. 8-33

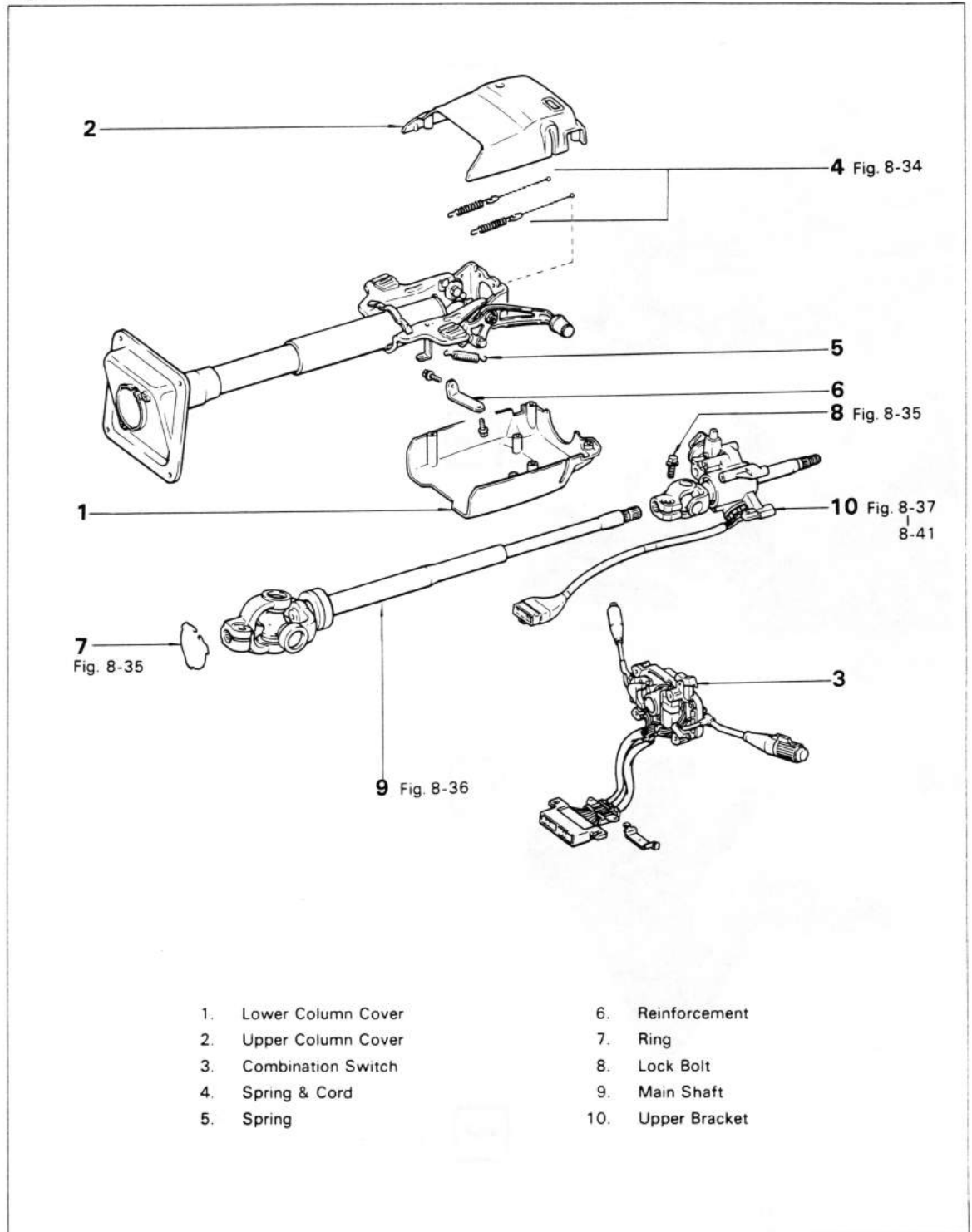

cardiagn.com

Fig. 8-34

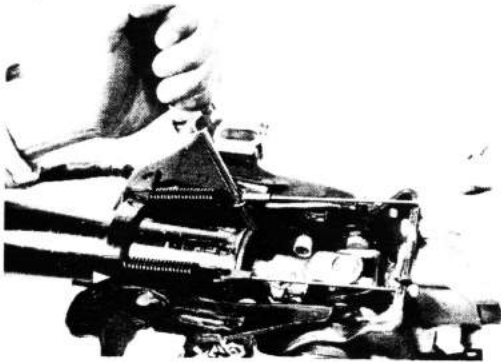

Extend the spring and remove the cord and spring.

Fig. 8-35

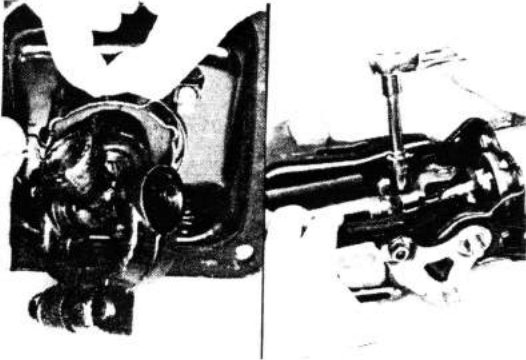

Remove the ring and bolt.

Fig. 8-36



Remove the shaft.

Fig. 8-37



Loosen the broken down bolt by tapping the chisel.

Fig. 8-38



Remove the upper bracket and main shaft.

Fig. 8-39

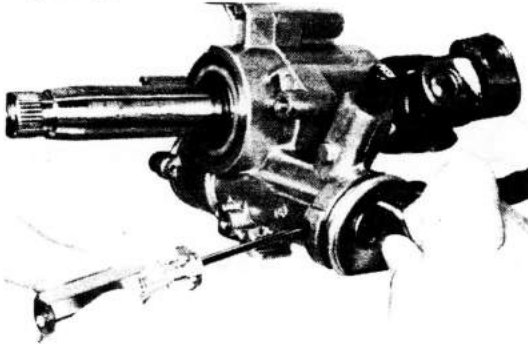

Position the key at ACC and push the knob. At this time, remove the key cylinder.

Fig. 8-40

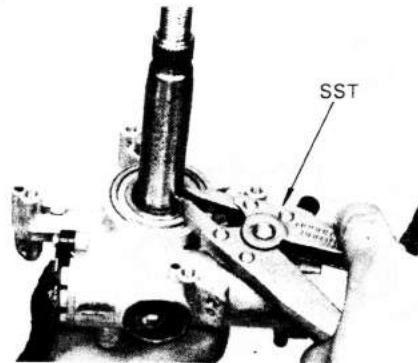

Remove the snap ring with SST. SST [09905-00012]

Fig. 8-41



Remove the upper bracket from the shaft.

2. Disassemble the parts in the numerical order shown in the figure.

Fig. 8-42

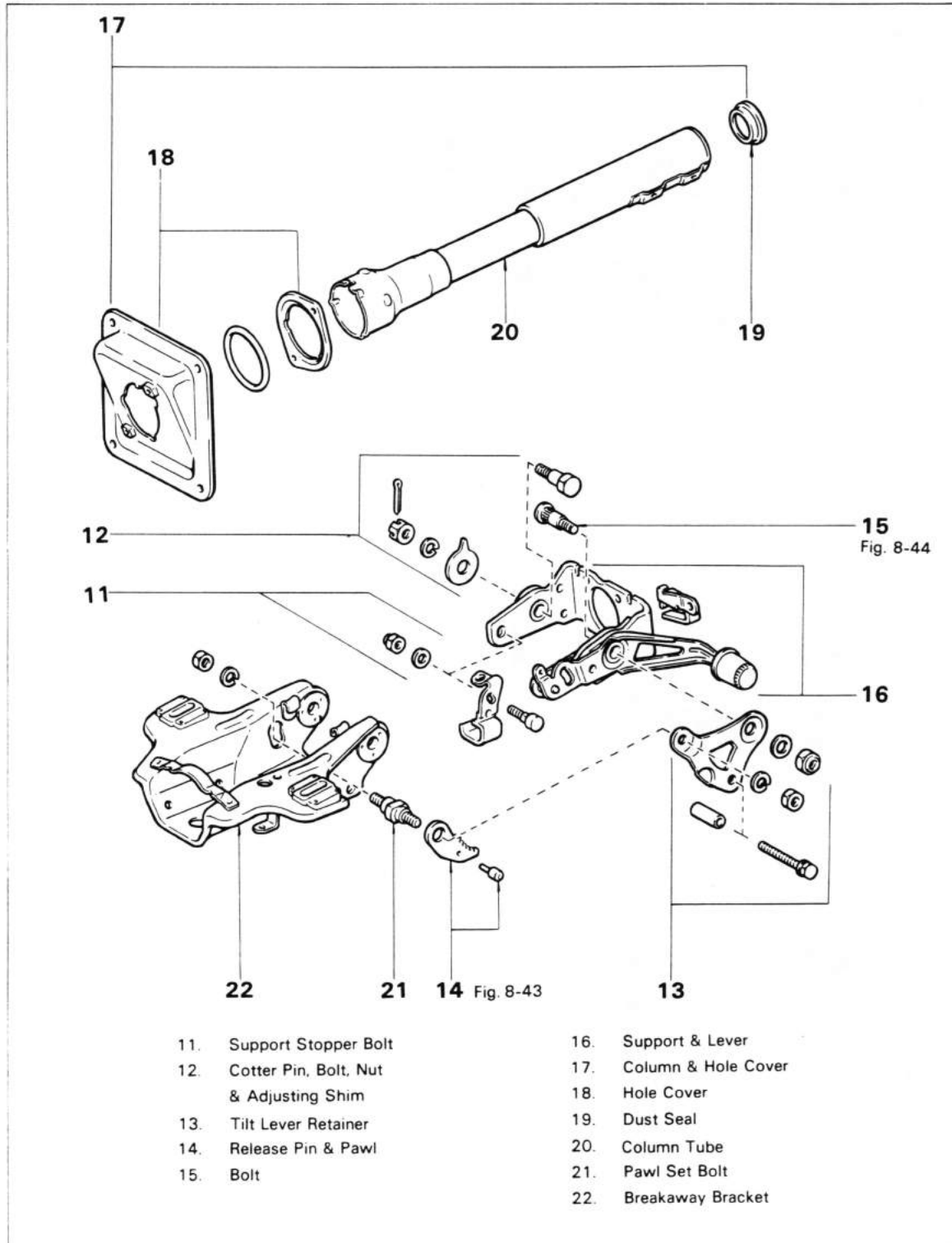

cardiagn.com

Fig. 8-43



Pull out the reclining pawl release pin and remove the tilt steering pawl.

Fig. 8-44



Temporarily install another nut flat with the end of the bolt and tap it in with a hammer.

Fig. 8-45

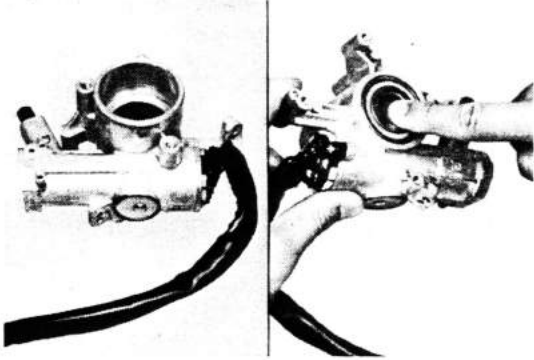
**INSPECTION & REPAIR****Upper Bracket**

1. Inspect the upper bracket for damage.
2. Inspect the bearing rotation.

Fig. 8-46

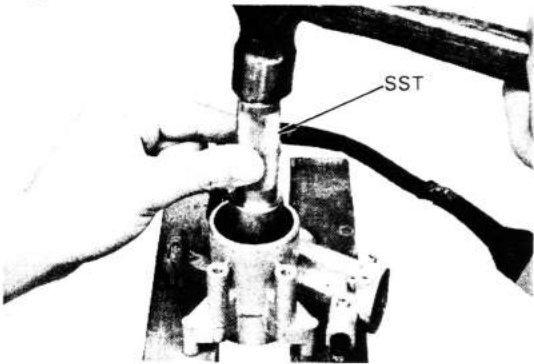
**Replace The Bearing**

1. Remove the bearing with SST.
SST [09620-30010]

Fig. 8-47

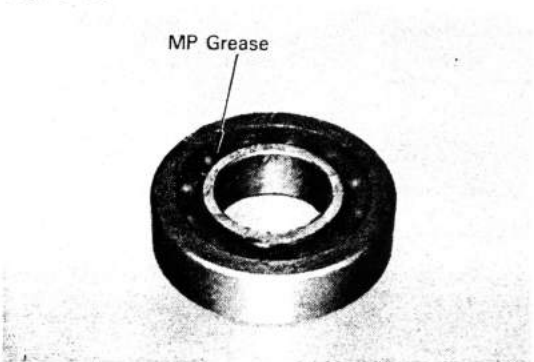

2. Pack MP grease into the new bearing.

Fig. 8-48

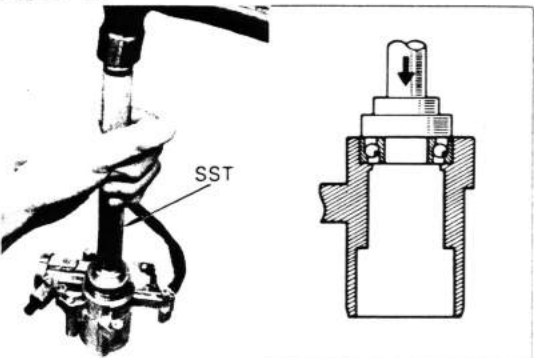

3. Install the bearing with SST.
SST [09620-30010]

Fig. 8-49

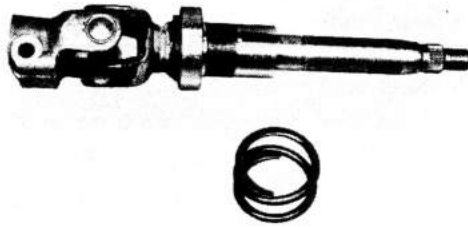

Main Shaft, Thrust Collar & Spring

1. Inspect for wear or damage.

Fig. 8-50

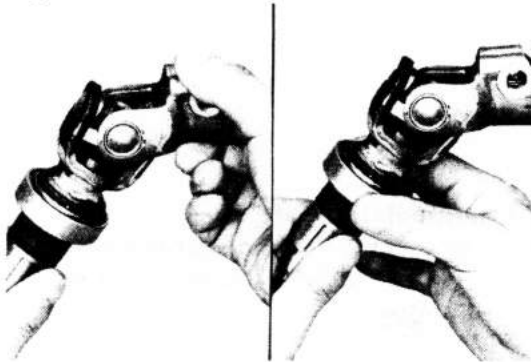

2. Inspect the universal joint for play or binding.
3. Inspect the bearing rotation.

Fig. 8-51

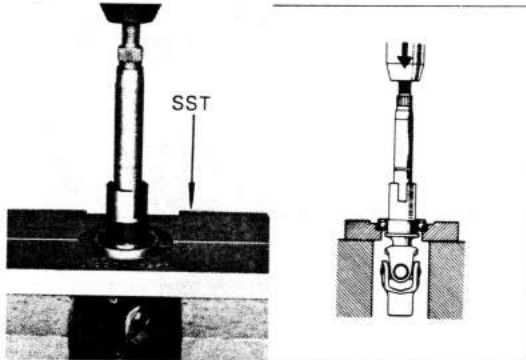

Replace The Bearing

1. Remove the bearing with a press and SST. SST [09527-20011]

Fig. 8-52

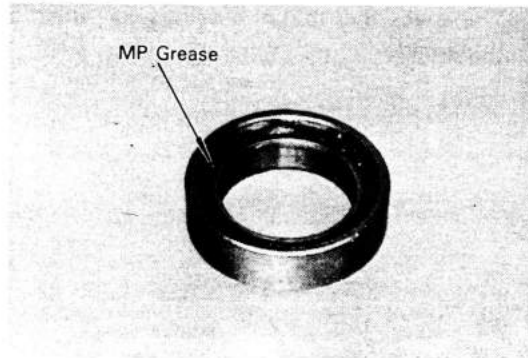

2. Pack MP grease into the new bearing.

Fig. 8-53

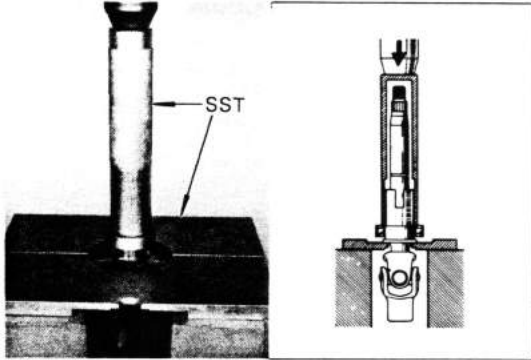

3. Install the bearing with a press and SST.
SST [09236-28011]
[09612-22010]

Fig. 8-54

**Intermediate Shaft**

1. Inspect the shafts for damage or bending.
2. Inspect the flexible coupling for wear or damage.

Fig. 8-55

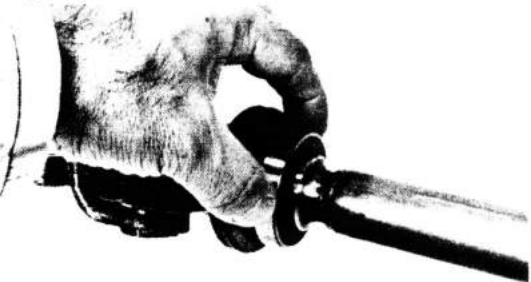

3. Inspect the bearing.

Fig. 8-56



4. Inspect the spider bearings for wear or damage.

Fig. 8-57

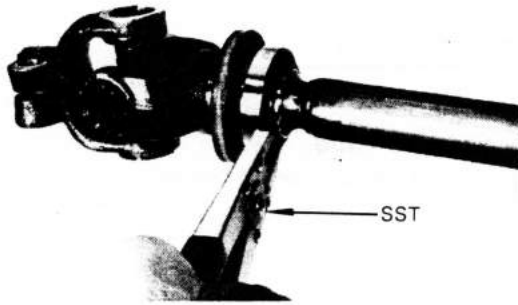

Replace The Bearing

1. Remove the snap ring with SST. SST [09905-00012]

Fig. 8-58

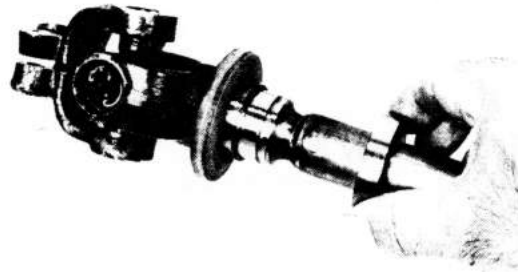

2. Replace the bearing.



Fig. 8-59

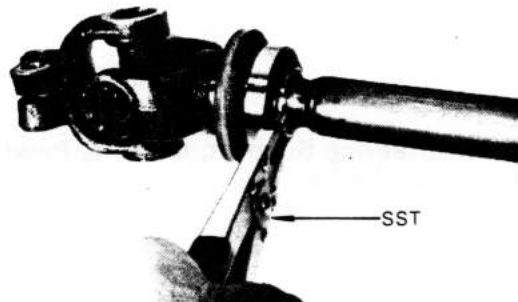

3. Install the snap ring with SST. SST [09905-00012]

Fig. 8-60

SEE
INTERMEDIATE
SHAFT SECTION
Fig. 8-8 to 8-16

Replace The Spider Bearing

Replace the spider bearing.

Fig. 8-61

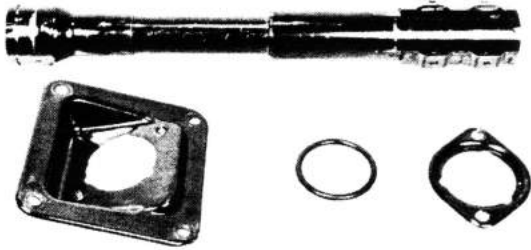

Column Tube

Inspect for damage or bending.

Fig. 8-62

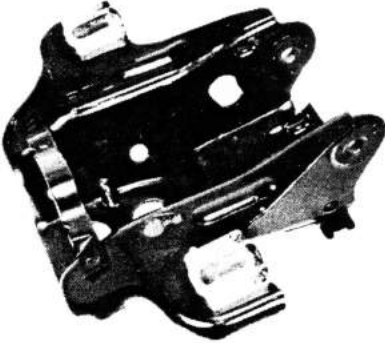

Breakaway Bracket

Inspect for wear or damage.

Fig. 8-63



Tilt Steering Support, Collar & Pawl

1. Remove the collar.

Fig. 8-64



2. Inspect the pawl for wear or damage.

Fig. 8-65



3. Inspect the support, collar and lever for wear or damage.

Fig. 8-66



Lever Retainer, Bolt & Nut
Inspect for wear or damage.

Fig. 8-67

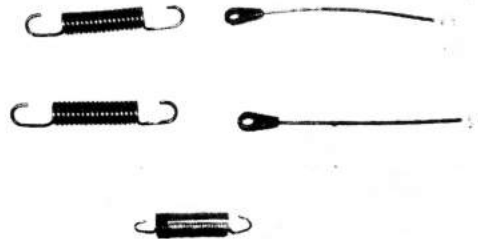

Spring & Cord
Inspect for wear or damage.

ASSEMBLY

1. Assemble the parts in the numerical order shown in the figure.

Fig. 8-68

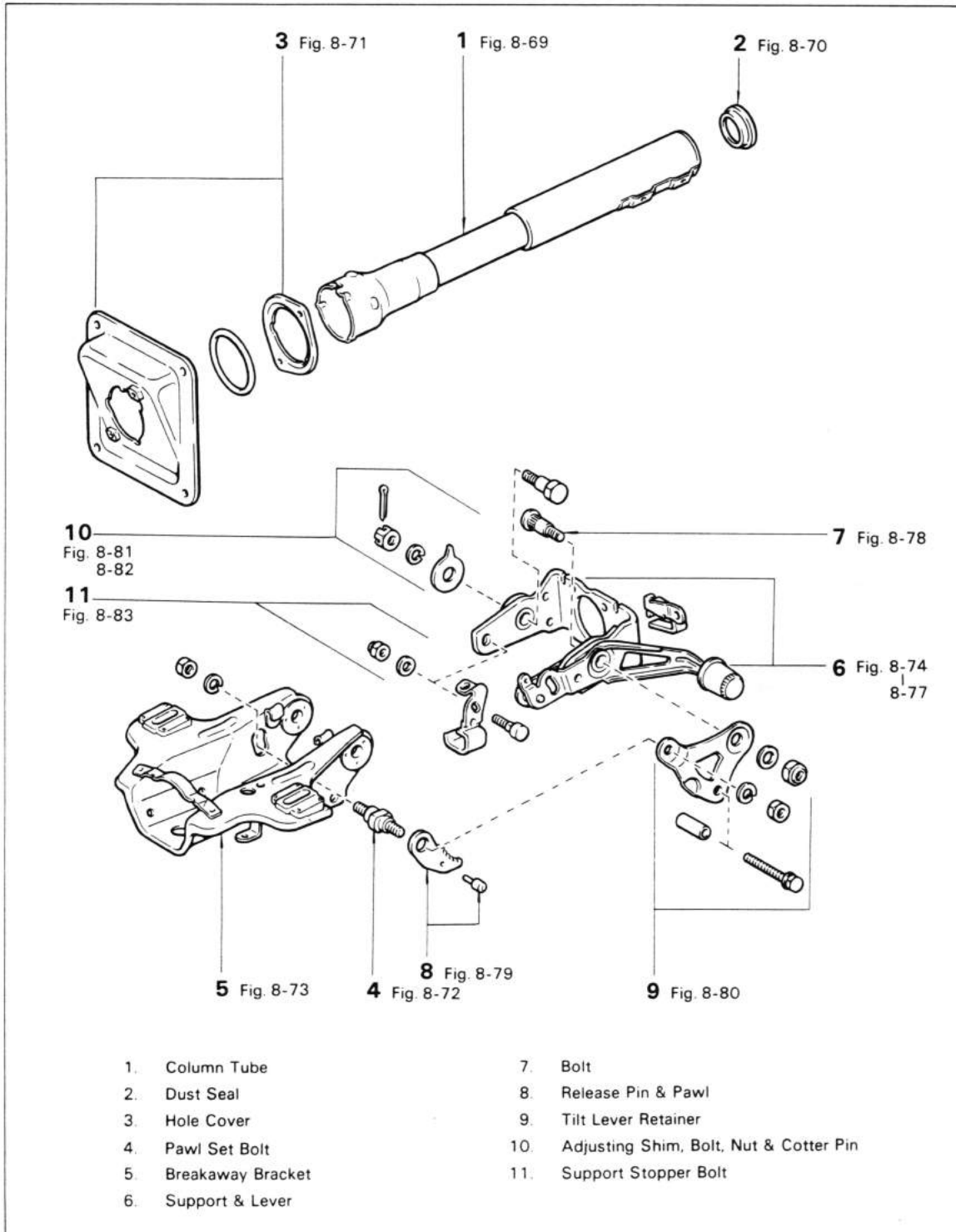

— Note —
Coat all rubbing parts with MP grease.

Fig. 8-69

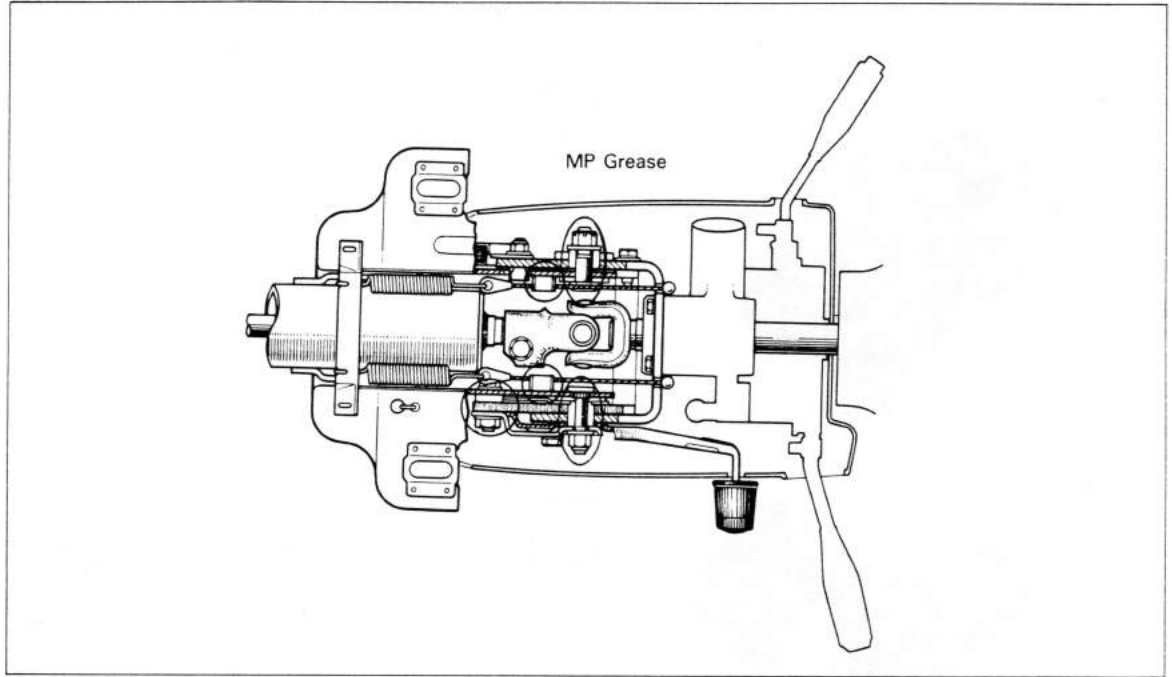
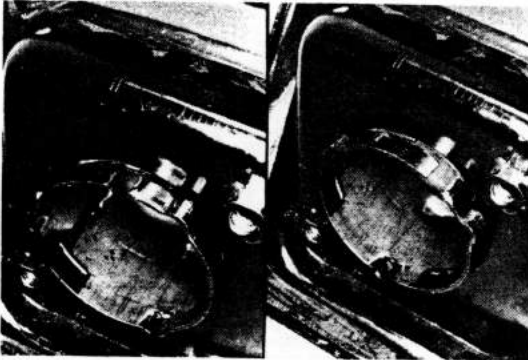

Fig. 8-70



Stick the dust seal with adhesive.

Fig. 8-71



Align the protrusion so that it fits into the column tube groove.

Fig. 8-72

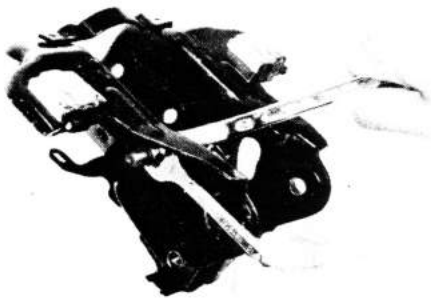

Tighten the pawl set bolt.

Tightening torque: 1.5 – 2.2 kg-m
(11 – 15 ft-lb)

Fig. 8-73

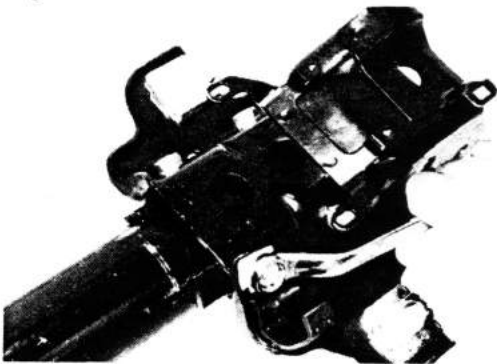

Install the column tube.

Tightening torque: 1.5 – 2.2 kg-m
(11 – 15 ft-lb)

Fig. 8-74



Install the lever onto the support.

Fig. 8-75



Install the tilt lever to the steering support.
Select a collar No.1 which will eliminate all play.

Collar No. 1 outer diameter	mm (in.)
17.989 – 17.996	(0.7082 – 0.7085)
17.996 – 18.003	(0.7085 – 0.7088)
18.003 – 18.010	(0.7088 – 0.7091)
18.010 – 18.017	(0.7091 – 0.7093)
18.017 – 18.024	(0.7093 – 0.7096)

Fig. 8-76



Select a collar No.2 which will eliminate all play.

Collar No.2 outer diameter		mm (in.)
17.982 – 18.000	(0.7080 – 0.7087)	
18.000 – 18.018	(0.7087 – 0.7094)	

Fig. 8-77



Install the lever on the support and collars.

Fig. 8-78

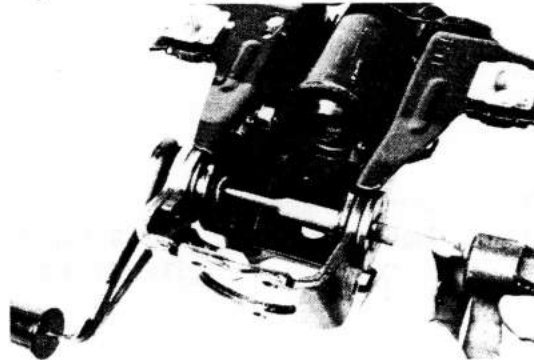

Drive in the serration bolt.

Fig. 8-79

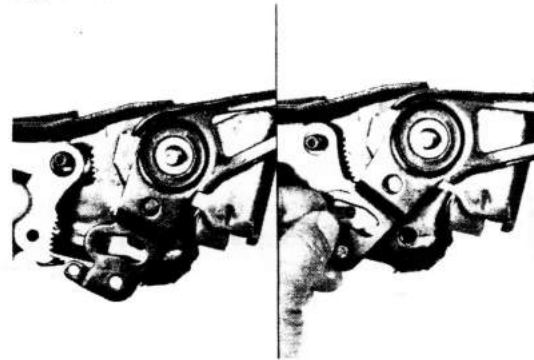

Install the tilt steering pawl and the reclining release pin.

Fig. 8-80

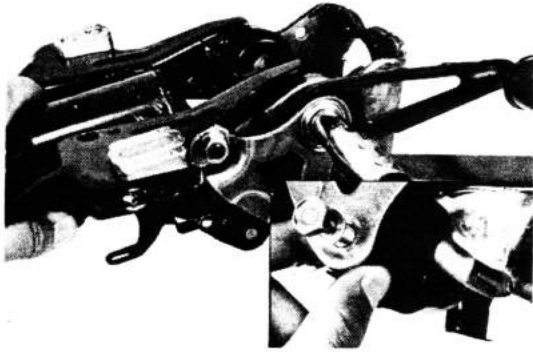

Install the collar one of the part.
Tighten the bolt and nuts.

**Tightening torque: 1.5 – 2.2 kg-m
(11 – 15 ft-lb)**

Fig. 8-81



Select a shim which fits snugly when pressed in by hand.

Shim thickness		mm (in.)
0.2 (0.008)	1.4 (0.055)	
0.5 (0.020)	1.8 (0.071)	
0.8 (0.031)		

Fig. 8-82



Tighten the castle nut.

**Tightening torque: 1.5–3.0 kg-m
(11–21 ft-lb)**

Fig. 8-83

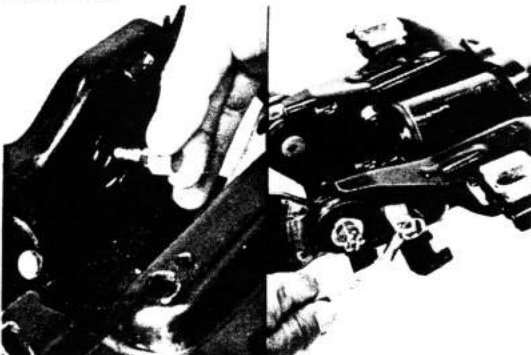

Install the tilt steering support stopper bolt.

**Tightening torque: 0.8–1.2 kg-m
(70–104 in.-lb)**

2. Assemble the parts in the numerical order shown in the figure.

Fig. 8-84

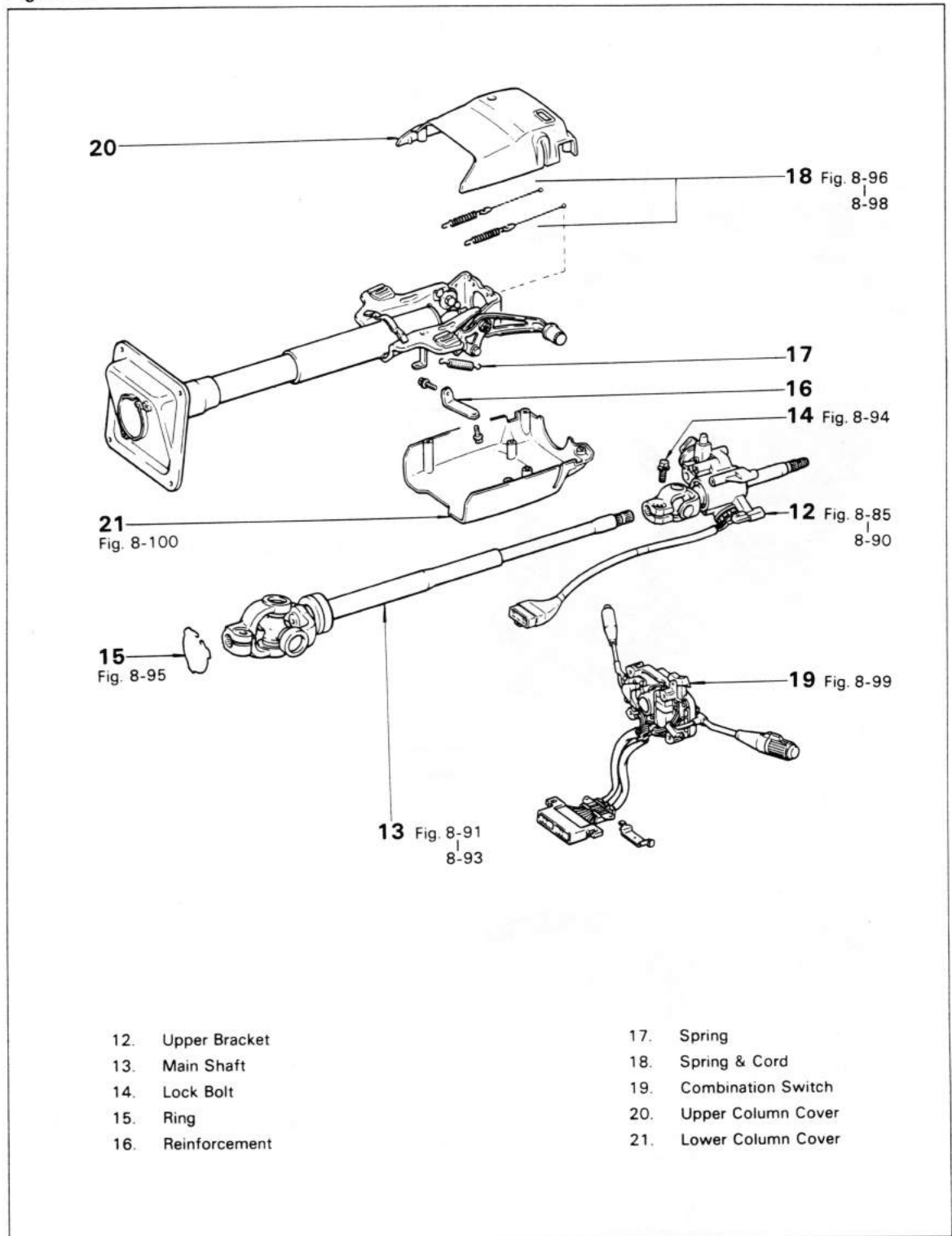

cardiagn.com

Fig. 8-85



Install the upper bracket and main shaft.

1. Install the spring seat facing as shown in the figure.

Fig. 8-86

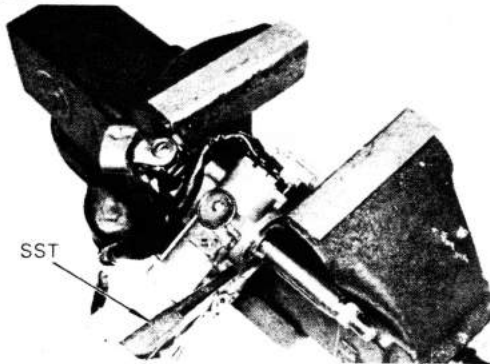

2. Using a vise, assemble the upper bracket to the main shaft with SST.
SST [09905-00012]

— Note —

Use a new snap ring.

Fig. 8-87



3. Insure that the upper bracket bearing turns smoothly.

Fig. 8-88



4. Install the upper bracket.

Tightening torque: 0.6 – 0.9 kg-m
(53 – 78 in.-lb)

Fig. 8-89

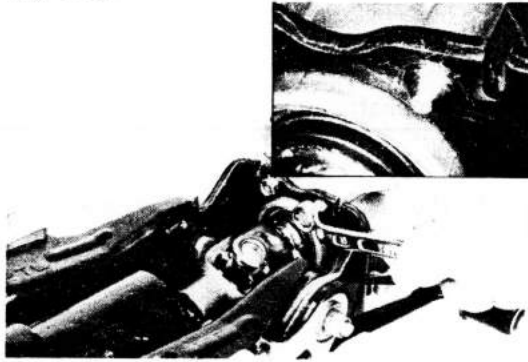

5. Using the new lock bolt, tighten the it until the tops break off.

Fig. 8-90

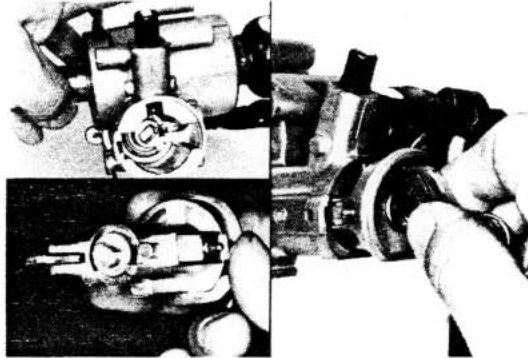

6. Turn the ignition key to the ACC position, and install the key cylinder into the upper bracket.

Fig. 8-91



Install the O ring on the outer race and teflon ring.

Fig. 8-92

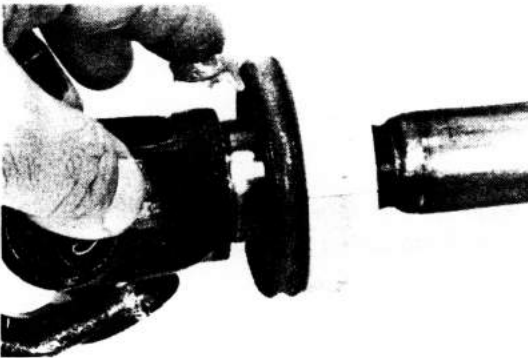

Coat MP grease on the shaft and oil seal.

Fig. 8-93

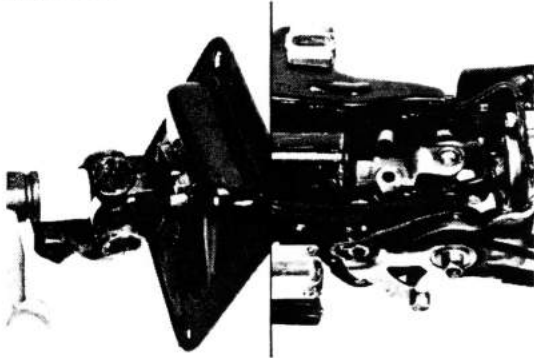

Align both side yoke direction when install the main shaft.

Fig. 8-94

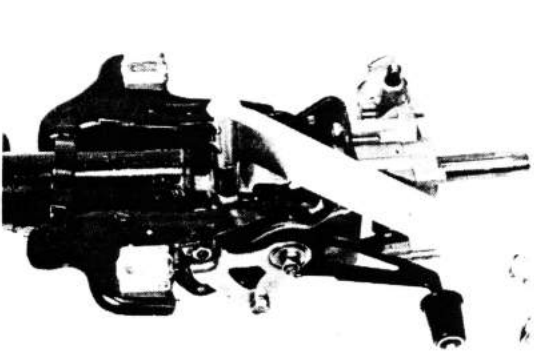

Tighten the clamp bolt.

Tightening torque: 2.0 - 3.0 kg-m
(15 - 21 ft-lb)

Fig. 8-95



Be sure that the retainer is properly assembled.

Fig. 8-96



Extend the spring with screwdriver when install the spring and cord.

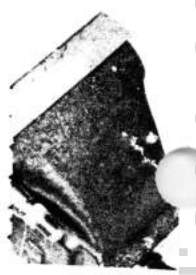
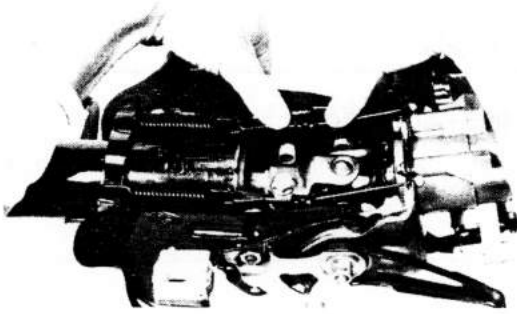
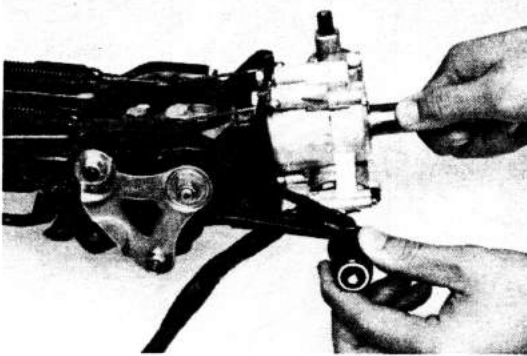

Fig. 8-97



Hook the cords.

Fig. 8-98



Check the operation of the tilt steering lever and support.

— Note —

1. Insure that there is no axial or horizontal play at the end of the main shaft.
2. Insure that the main shaft is locked securely in all 6 positions.

Fig. 8-99

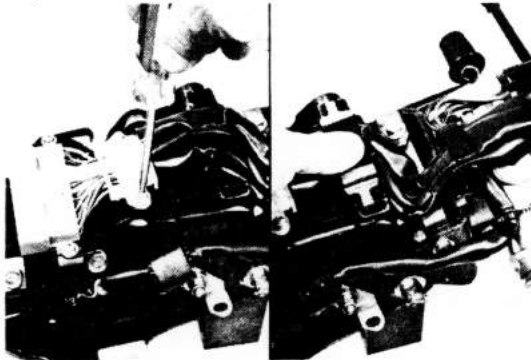

Install the connector and wiring band on the column.

Fig. 8-100

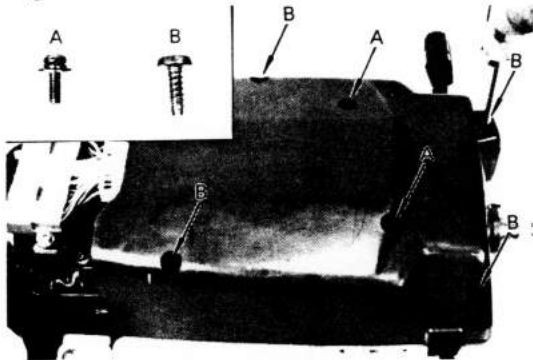

Install the column cover.

INSTALLATION

Install the parts in the numerical order shown in the figure.

Fig. 8-101

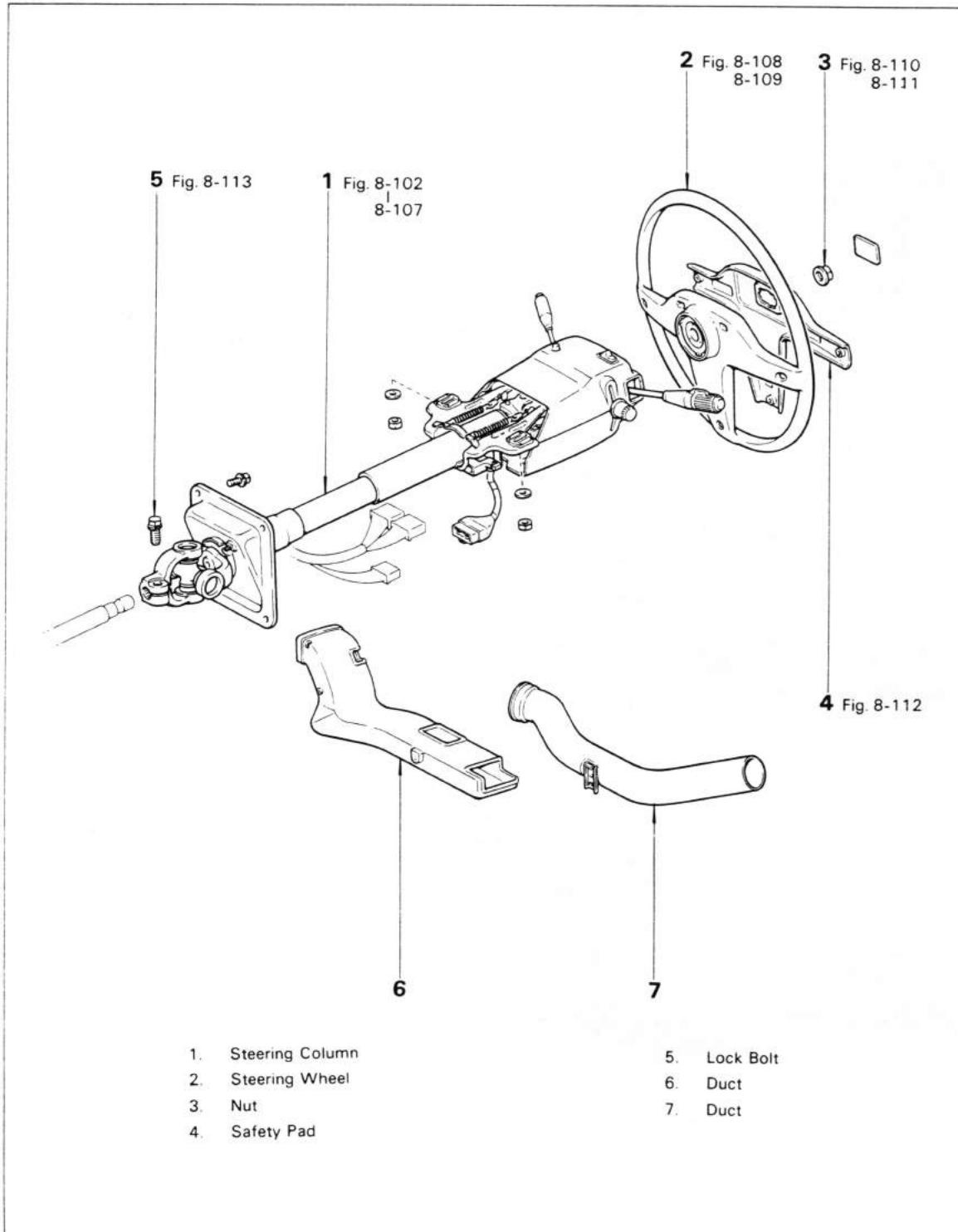
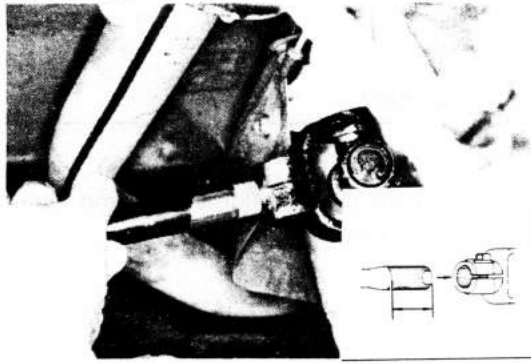
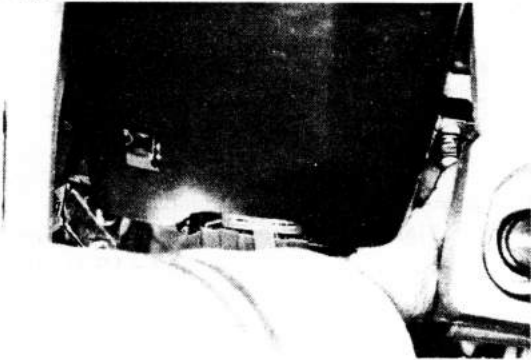

Fig. 8-102



Align the non-toothed portions of intermediate shaft and yoke.

Fig. 8-103



Temporarily tighten the breakaway bracket nuts.

Fig. 8-104

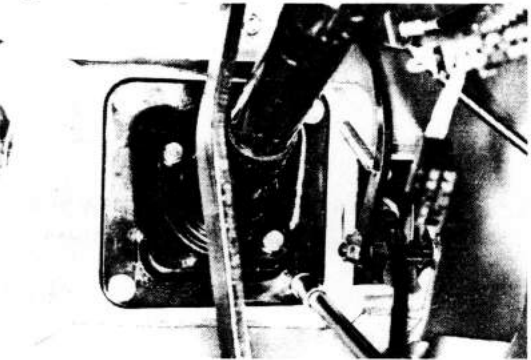

Tighten the column hole cover.

Tightening torque: 1.0 – 1.6 kg-m
(8 – 11 ft-lb)

Fig. 8-105

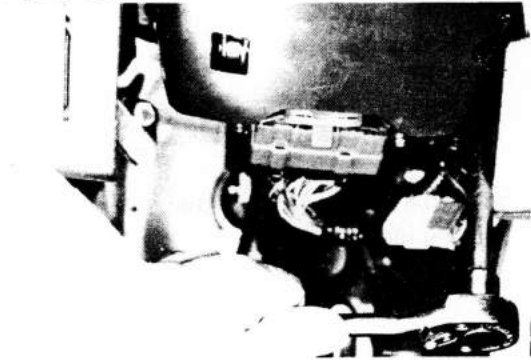

Tighten the breakaway bracket nuts.

Tightening torque: 1.9 – 3.1 kg-m
(14 – 22 ft-lb)

Fig. 8-106

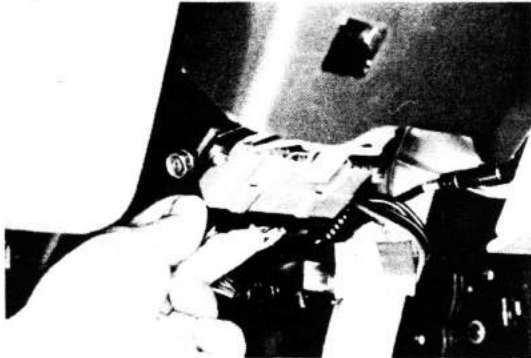

Connect the combination switch and ignition switch connectors.

Fig. 8-107

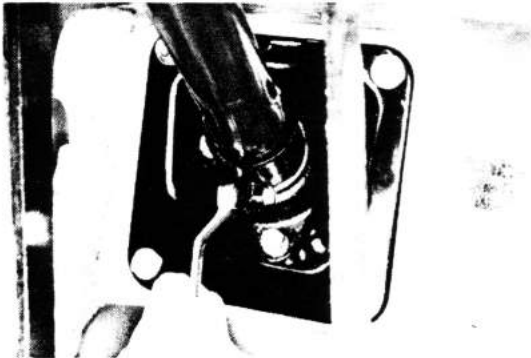

Tighten the column tube clamp.

**Tightening torque: 1.5–2.2 kg-m
(11–15 ft-lb)**

Fig. 8-108

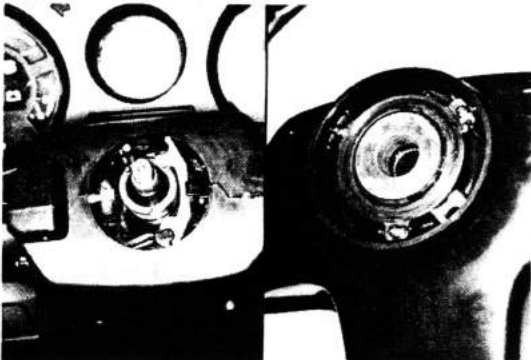

Align the turn signal cancel cam claw and the steering wheel, and then assemble them.

Fig. 8-109

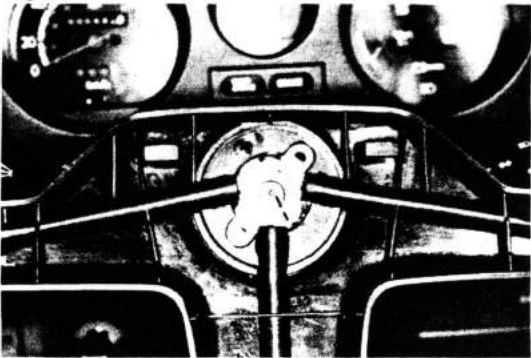

Align the matchmarks on the steering wheel and the main shaft.

Fig. 8-110

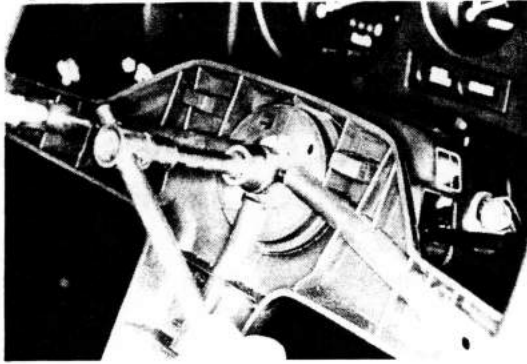

Tighten the steering wheel mounting nut.
Tightening torque: 3.0 – 4.0 kg-m
(22 – 28 ft-lb)

Fig. 8-111



Insure that the turn signal automatic cancel lever functions properly.

Fig. 8-112

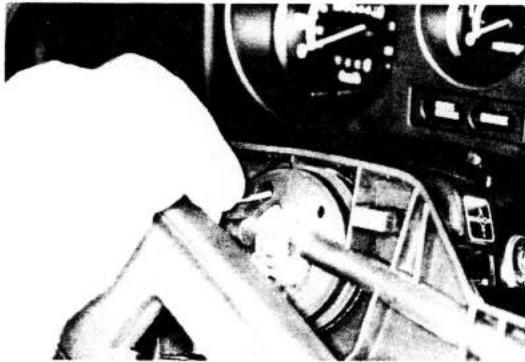

Connect the horn switch connector.

Fig. 8-113

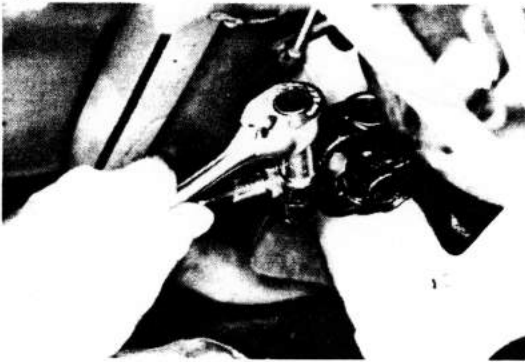

Tighten the yoke bolts.
Tightening torque: 3.0 – 4.5 kg-m
(22 – 32 ft-lb)

STEERING COLUMN & MAIN SHAFT (FJ, BJ, HJ6 — SERIES)

Fig. 8-114

SEE
TILT TYPE STEERING
COLUMN & MAIN
SHAFT REMOVAL SECTION
Fig. 8-30 to 3-32

REMOVAL

Remove the steering column.

DISSAEMBLY

Disassemble the parts in the numerical order shown in the figure.

Fig. 8-115

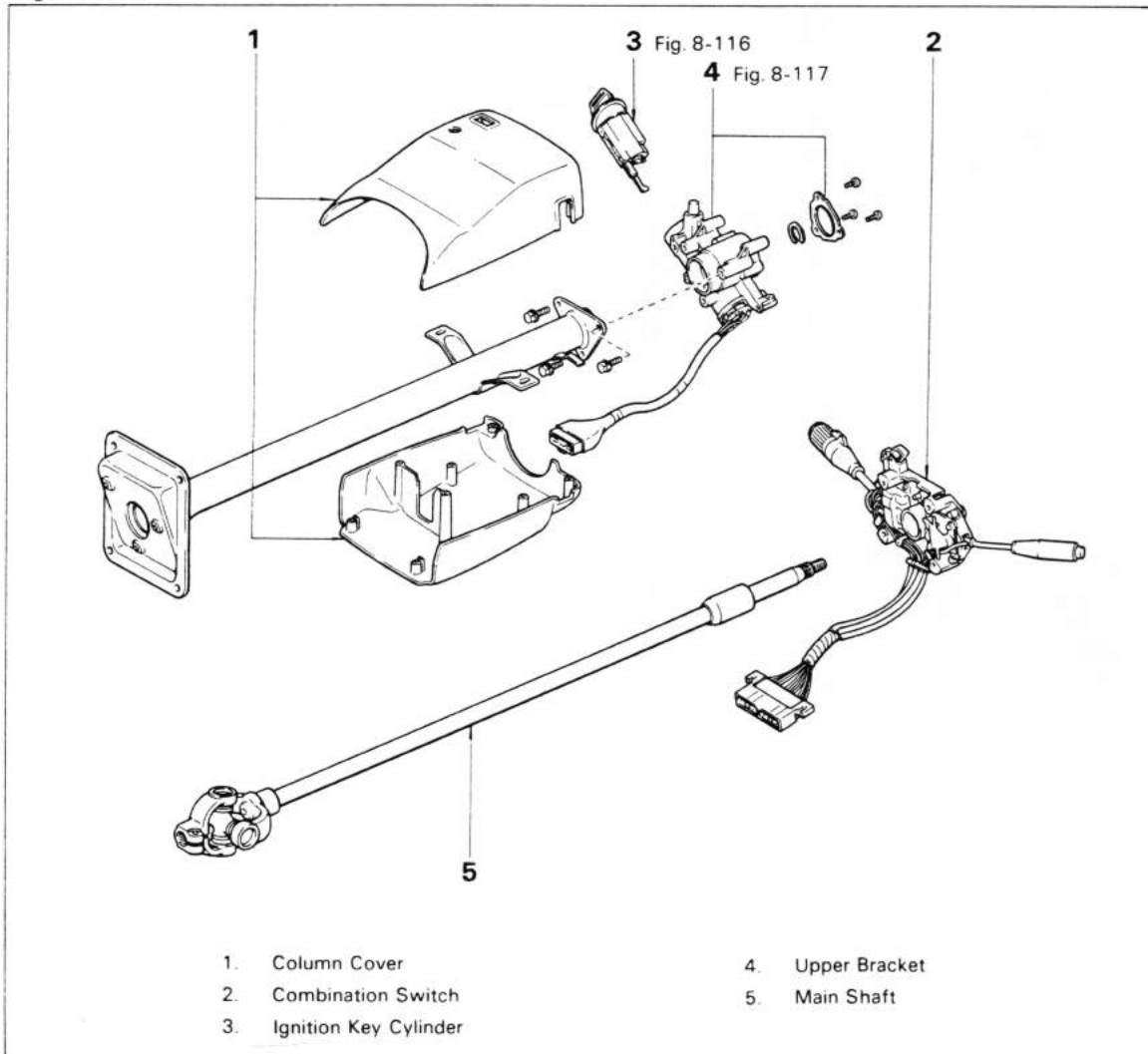
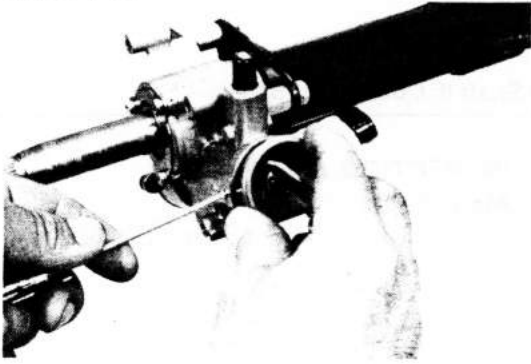
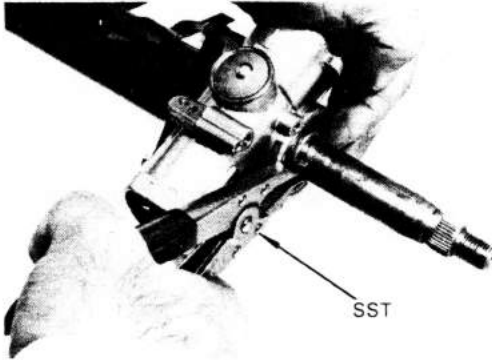

Fig. 8-116



Position the key at ACC and push the knob. At this time, remove the key cylinder.

Fig. 8-117



Remove the snap ring with SST. SST [09905-00012]

Fig. 8-118

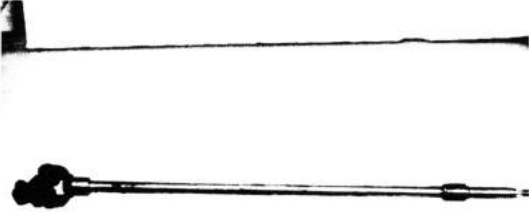
**INSPECTION & REPAIR****Main Shaft**

1. Check the shaft for damage or berding.

Fig. 8-119



2. Check the spider bearing for wear or damage.

Fig. 8-120

SEE
INTERMEDIATE
SHAFT SECTION
Fig. 8-8 to 8-16

Replace The Spider Bearing

Replace the spider bearing.

Fig. 8-121

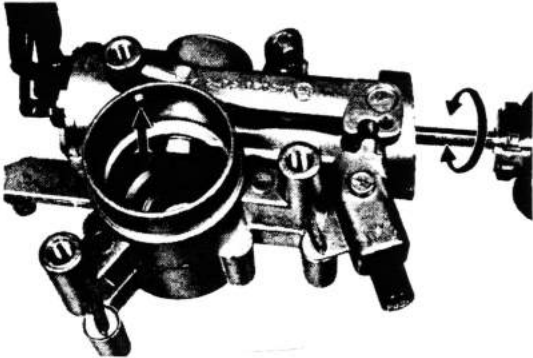
**Upper Bracket**

1. Check the steering lock system.

Fig. 8-122

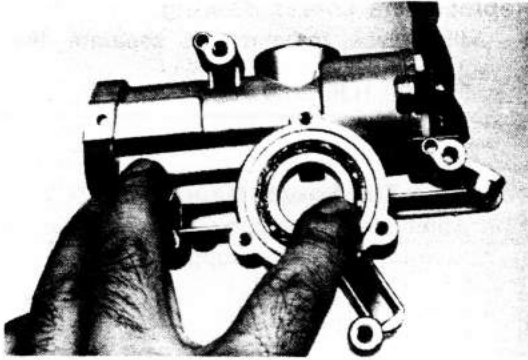

2. Check the bearing for rotation condition.

Fig. 8-123

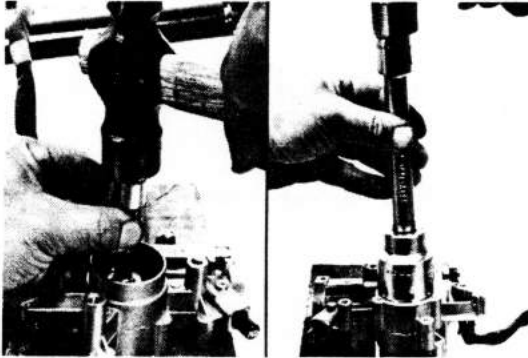

Replace The Upper Bearing

1. Remove the bearing.
2. Install the bearing until its upper surface is even with the bracket surface.



Fig. 8-124

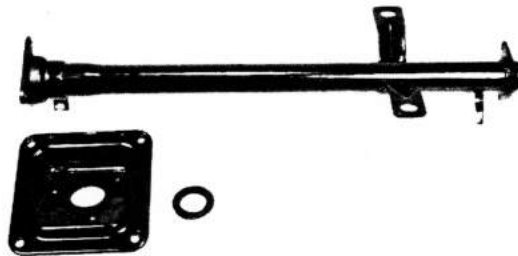

Column Tube & Hole Cover

Check for wear or damage.

Fig. 8-125

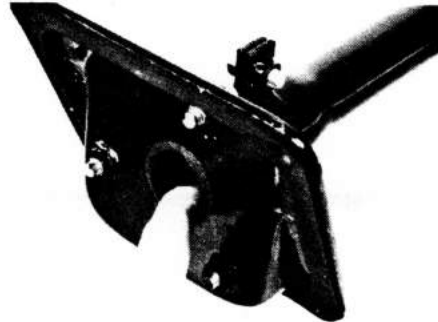

Lower Bearing

Check for rotation condition.

Fig. 8-126



Replace The Lower Bearing

1. After place matchmarks, separate the tube from the tube support.

Fig. 8-127

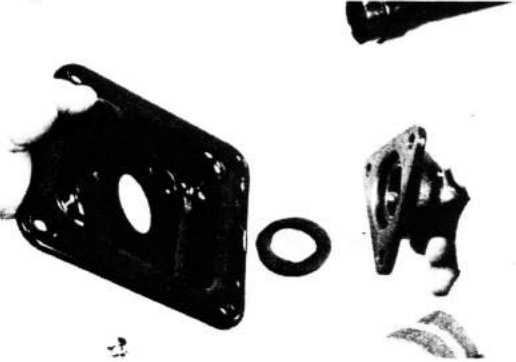

2. Remove the hole cover.

Fig. 8-128

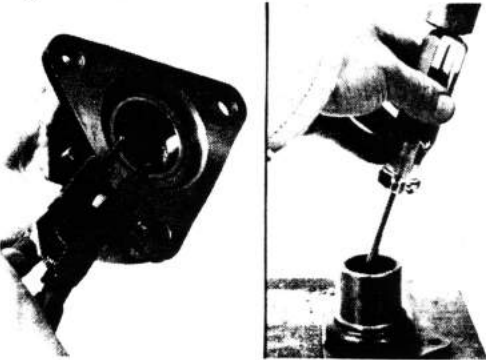

3. Remove the snap ring and bearing.

Fig. 8-129

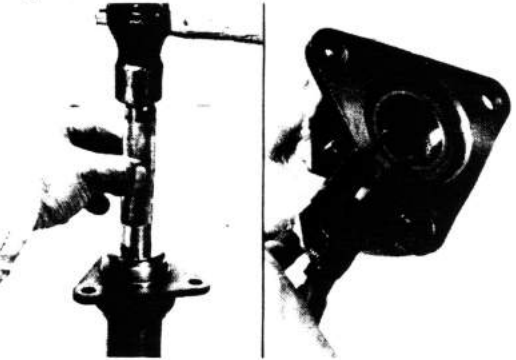

4. Install the new bearing and snap ring.

Fig. 8-130

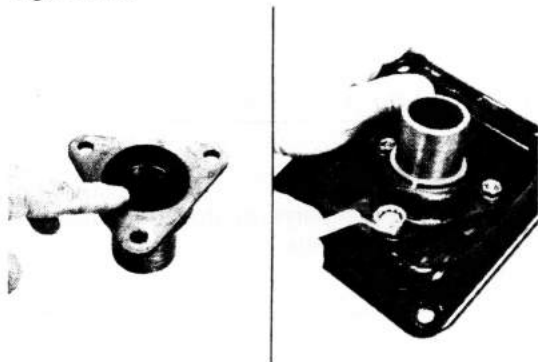

5. Install the dust seal on the bearing.
6. Install the hole cover.

Fig. 8-131

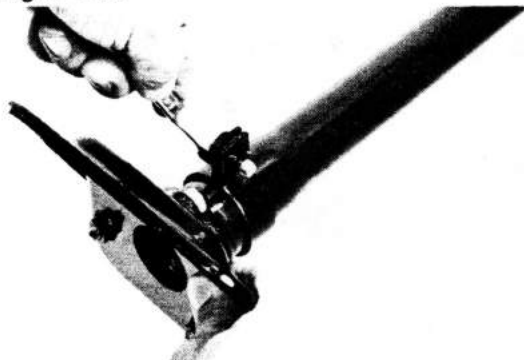

7. Align the matchmarks and temporarily tighten the tube clamp bolt.

— Note —

After installing the steering column on the vehicle, retighten the it.

ASSEMBLY

Assemble the parts in the numerical order shown in the figure.

Fig. 8-132

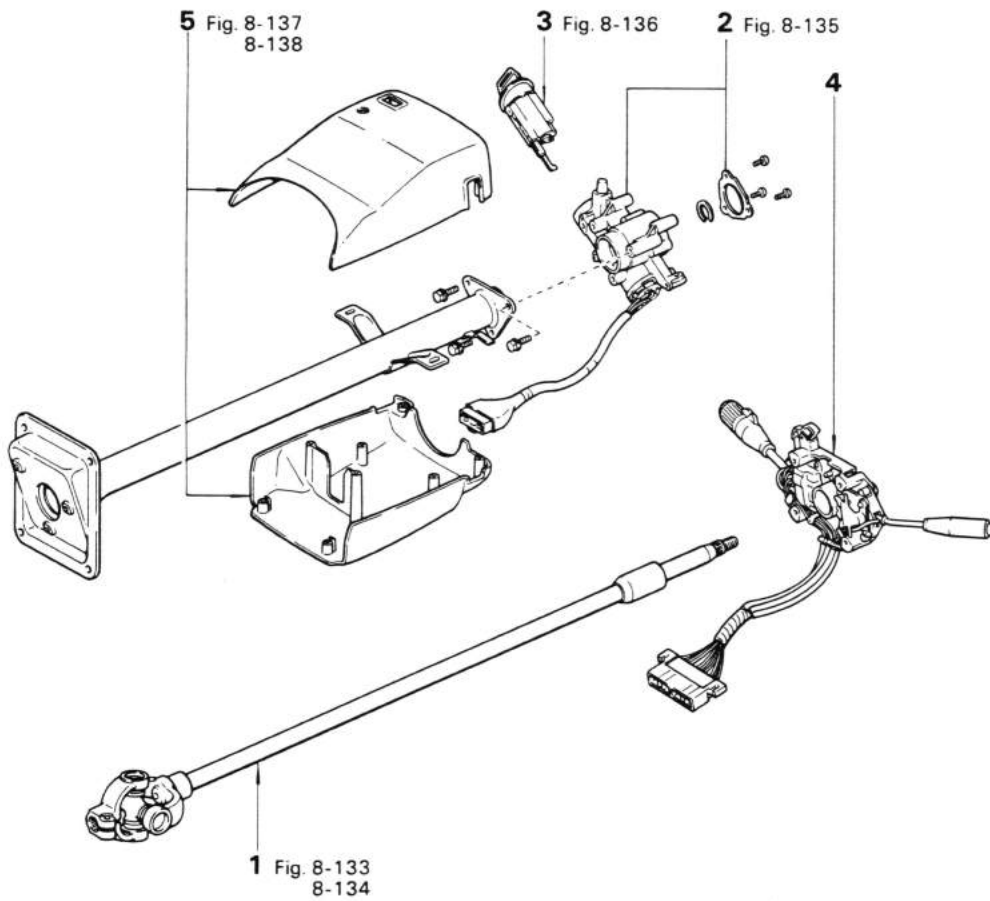

1. Main Shaft
2. Upper Bracket
3. Ignition key Cylinder
4. Combination Switch
5. Column Cover

Fig. 8-133

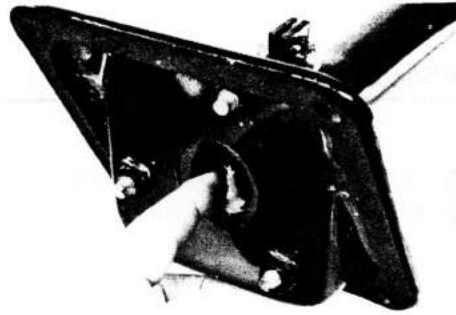

Coat the dust seal with MP grease.

Fig. 8-134

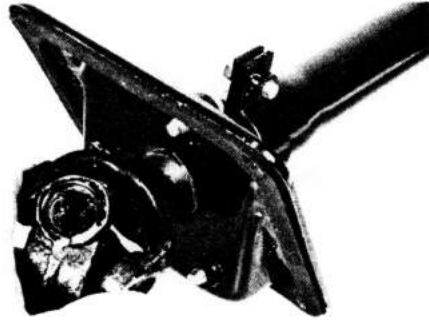

Apply MP grease to the dust seal and make sure it doesn't turn over when inserting the main shaft.

Fig. 8-135

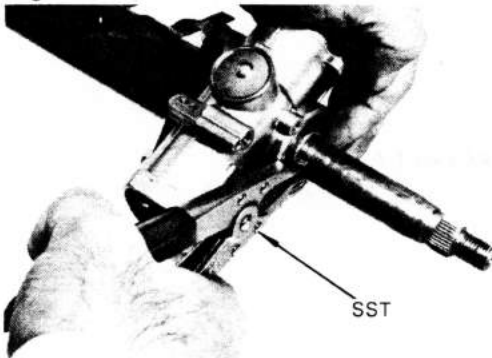

Install the snap ring with SST.
SST [09905-00012]

Fig. 8-136

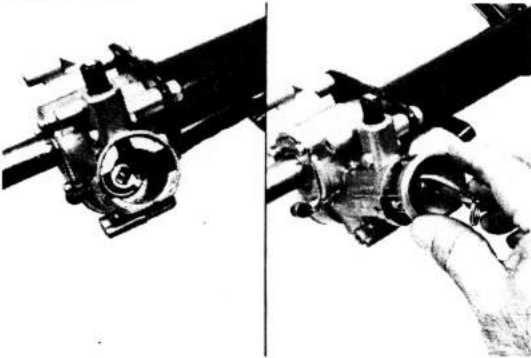

Turn the key to the ACC position, and install the key cylinder.

Fig. 8-137

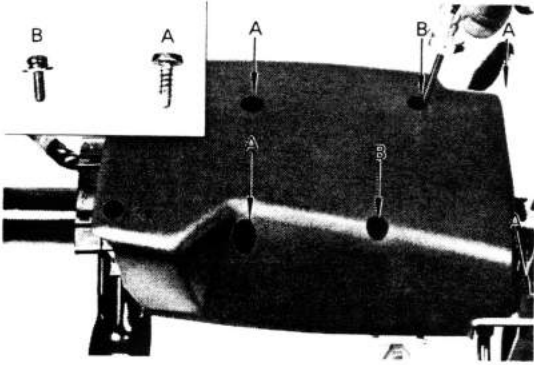

Be sure the screws are put in the proper places when installing the column cover.

Fig. 8-138

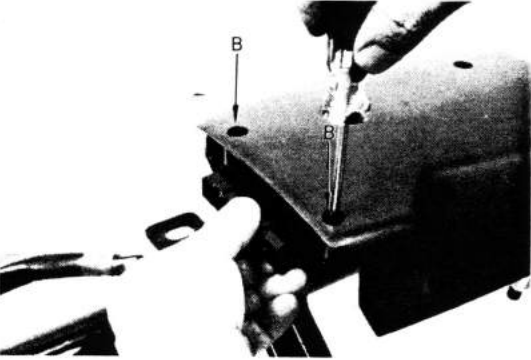

Install the connector on the lower cover.

Fig. 8-139

SEE
TILT TYPE STEERING COLUMN &
MAIN SHAFT INSTALLATION
SECTION
Fig. 8-101 to 8-113

INSTALLATION

Install the steering column.

STEERING COLUMN & MAIN SHAFT

(FJ, BJ, HJ4 — SERIES) REMOVAL

Remove the parts in the numerical order shown in the figure.

Fig. 8-140

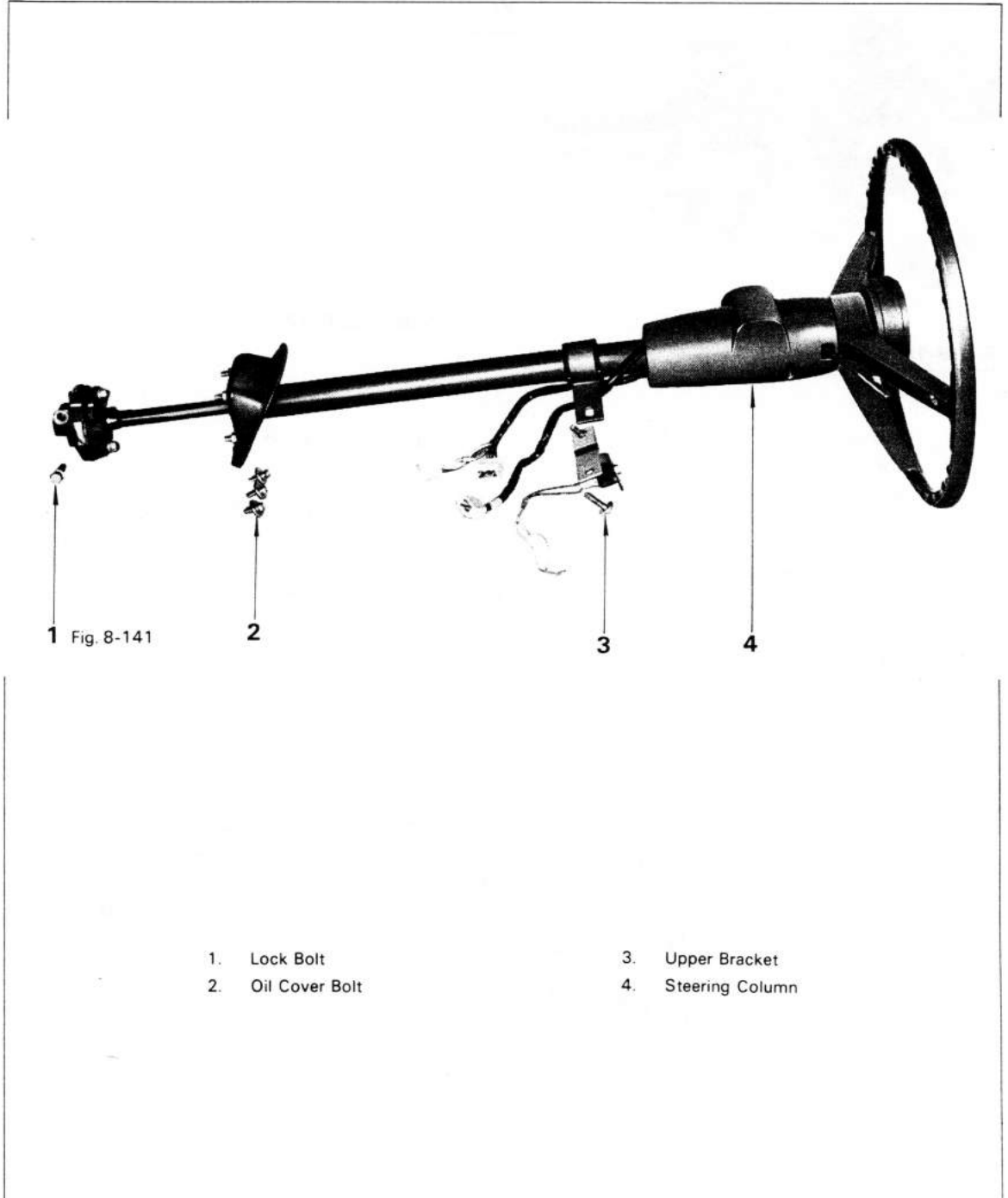

- 1. Lock Bolt
- 2. Oil Cover Bolt

- 3. Upper Bracket
- 4. Steering Column

Fig. 8-141

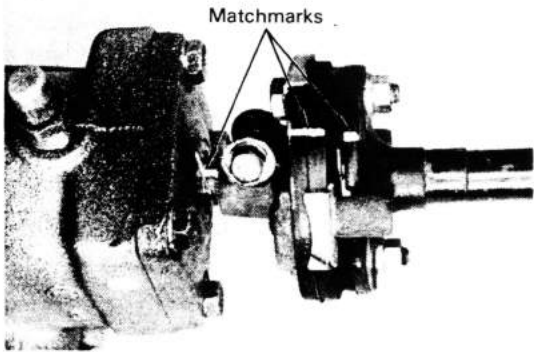

Place matchmarks on the gear box, couplings, and main shaft.

COMPONENTS

Fig. 8-142

- 1. Retainer
- 2. Bearing
- 3. Upper Bracket
- 4. Column Cover
- 5. Column Tube
- 6. Breakaway Bracket
- 7. Hole Cover
- 8. Main Shaft
- 9. Bearing
- 10. Retainer
- 11. Spring
- 12. Cover
- 13. Anti-rattle
- 14. Block
- 15. Shaft

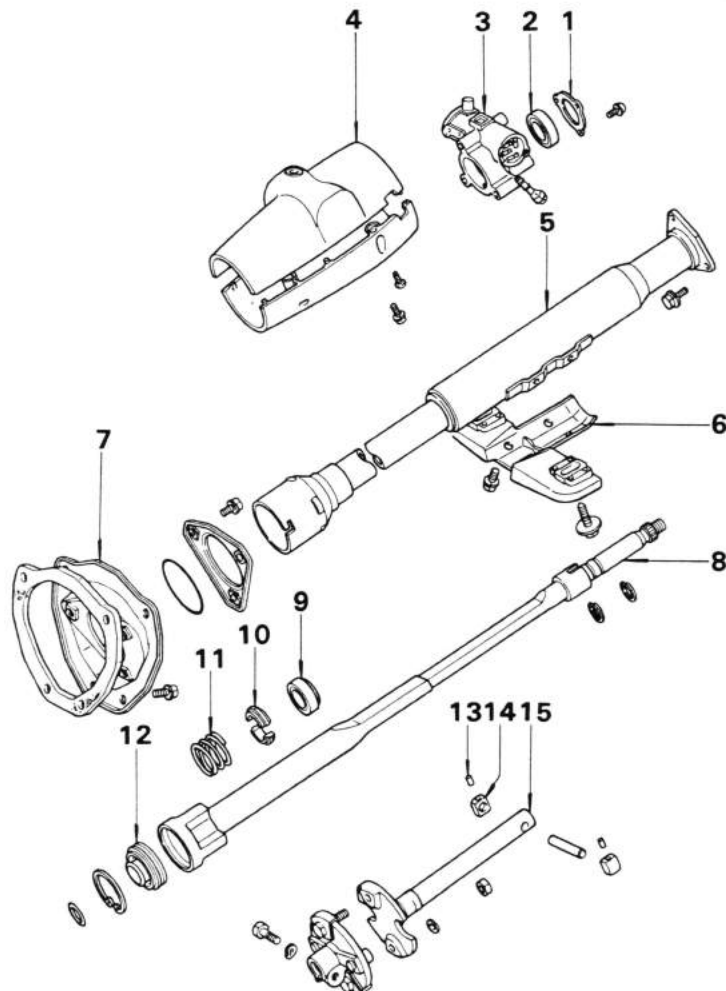

DISASSEMBLY

Disassemble the parts in the numerical order shown in the figure.

Fig. 8-143

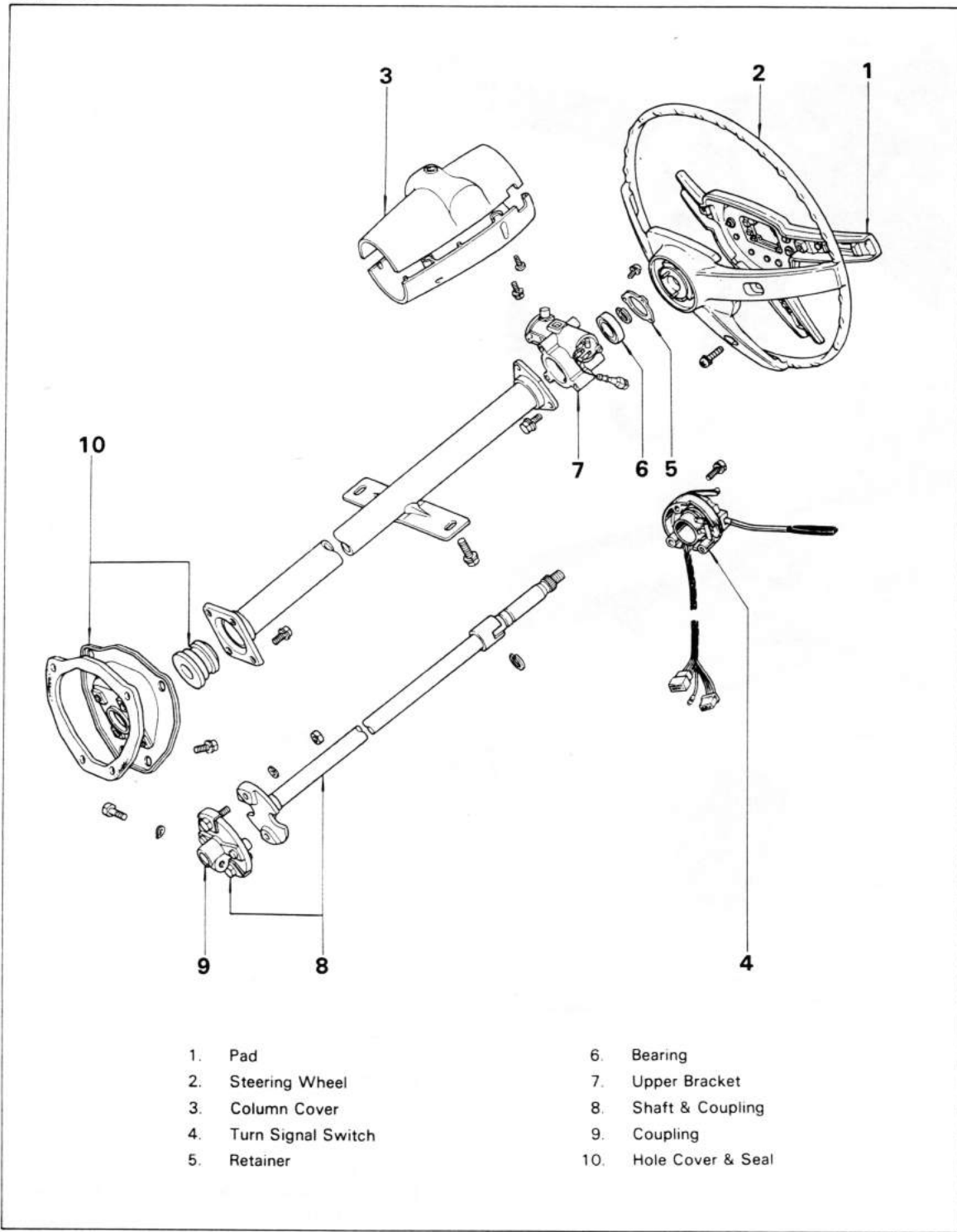

- | | |
|-----------------------|-----------------------|
| 1. Pad | 6. Bearing |
| 2. Steering Wheel | 7. Upper Bracket |
| 3. Column Cover | 8. Shaft & Coupling |
| 4. Turn Signal Switch | 9. Coupling |
| 5. Retainer | 10. Hole Cover & Seal |

Fig. 8-144

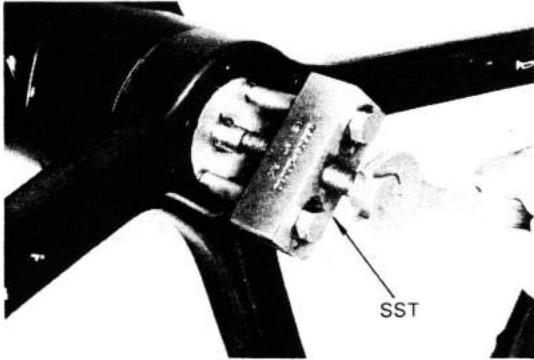

Place matchmarks on the shaft and steering wheel.

Remove the steering wheel with SST.
SST [09609-20010]

Fig. 8-145

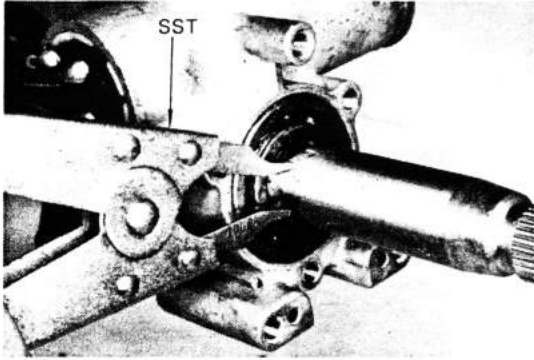

Remove the snap ring with SST.
SST [09905-00012]

Fig. 8-146

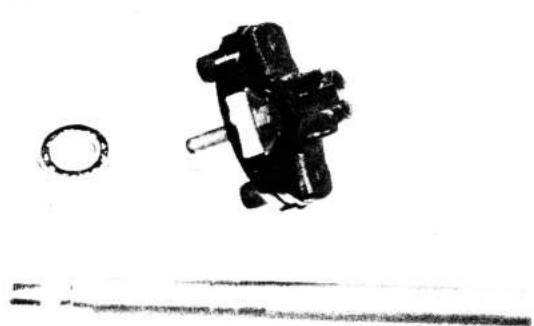

INSPECTION

Inspect the shaft, bearing, and coupling for wear, damage or cracks.

ASSEMBLY

Perform the disassembly in reverse order.

— Note —

1. Pack grease into the upper bearing.
2. Align the matchmarks when installing the steering wheel.

INSTALLATION

Perform the removal in reverse order.

— Note —

Align the matchmarks when installing the steering column assembly.

STEERING GEAR HOUSING (FJ, BJ, HJ6—SERIES)

REMOVAL

Remove the parts in the numerical order shown in the figure.

Fig. 8-147

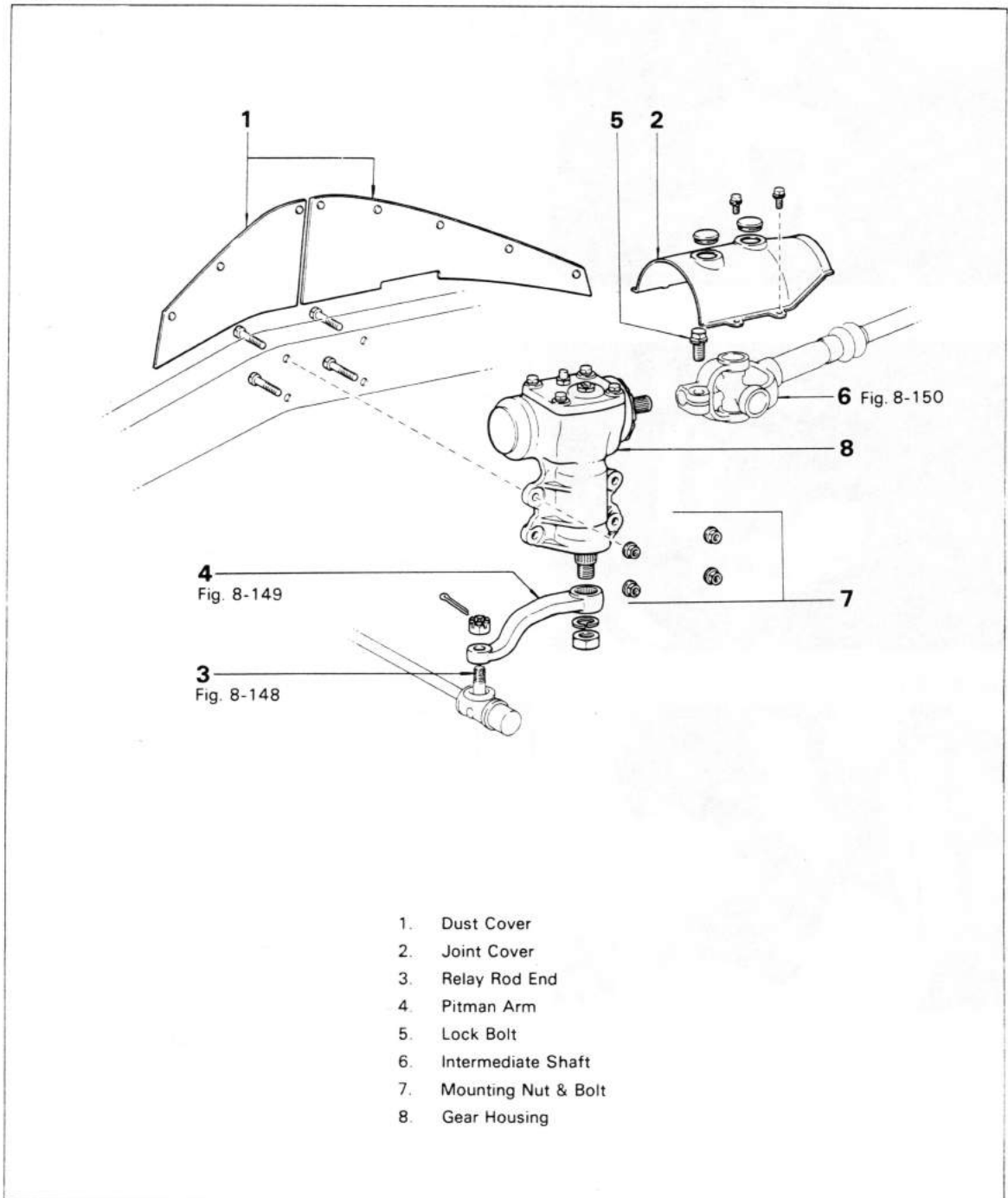
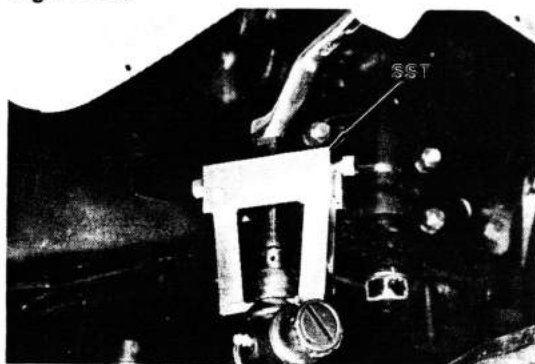
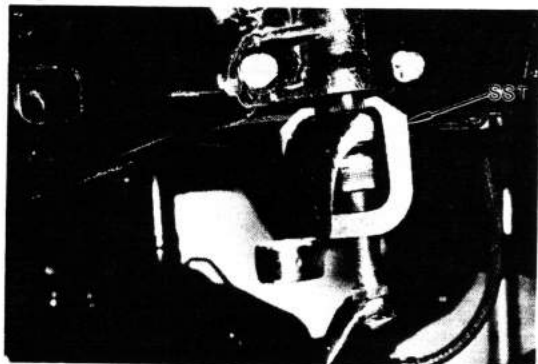

Fig. 8-148



Remove the pitman arm with SST.
SST [09628-62010]

Fig. 8-149



Disconnect the tie rod end with SST.
SST [09610-55012]

Fig. 8-150

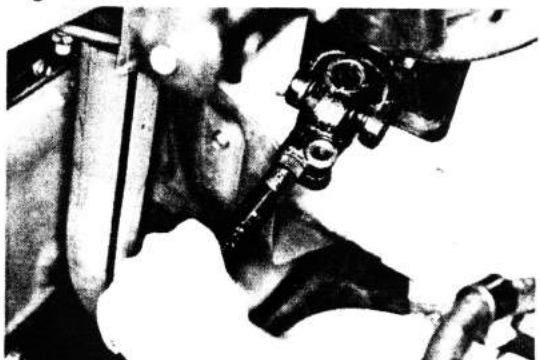

Remove the intermediate shaft.

DISASSEMBLY

Disassemble the parts in the numerical order shown in the figure.

Fig. 8-151

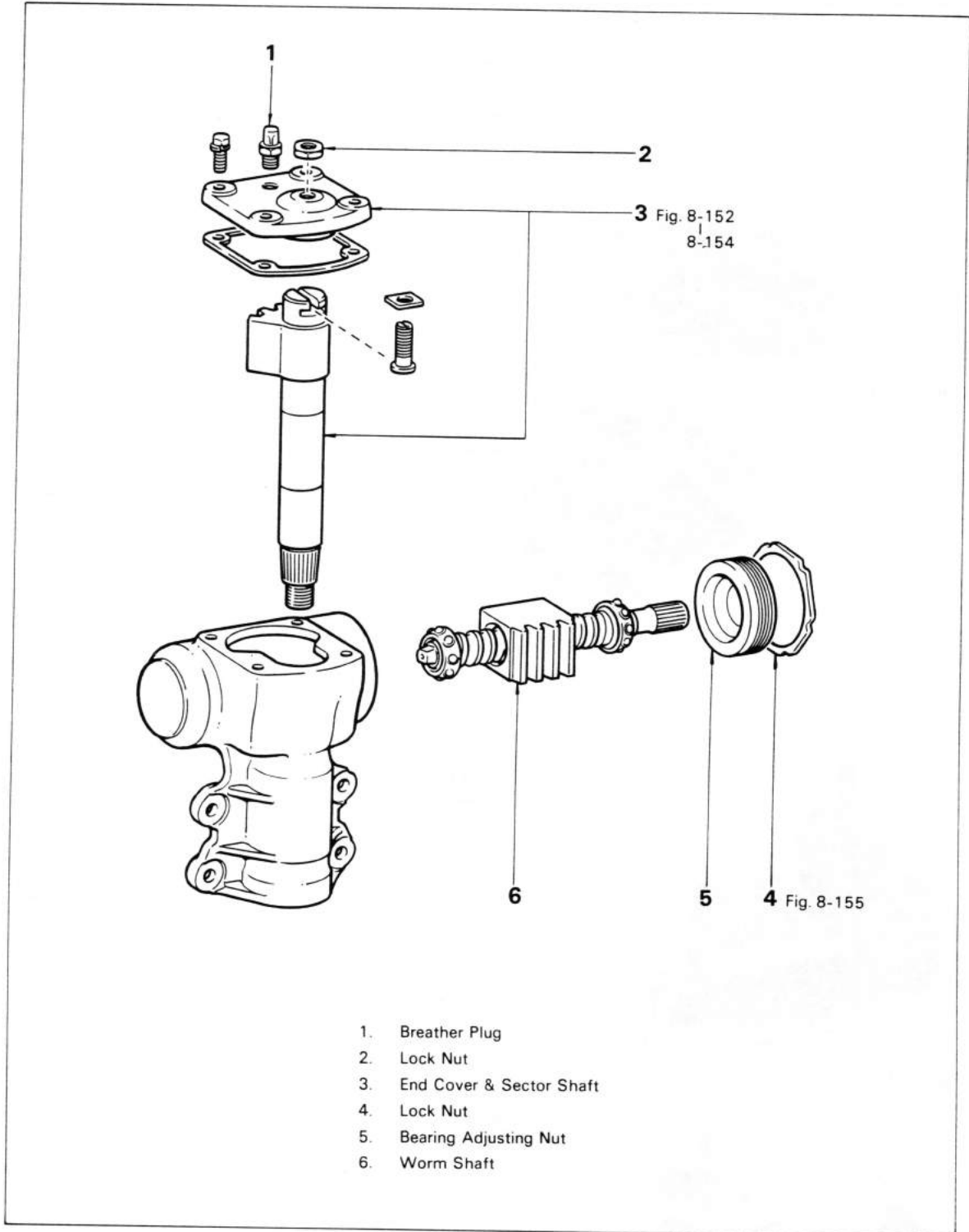

- 1. Breather Plug
- 2. Lock Nut
- 3. End Cover & Sector Shaft
- 4. Lock Nut
- 5. Bearing Adjusting Nut
- 6. Worm Shaft

Fig. 8-152

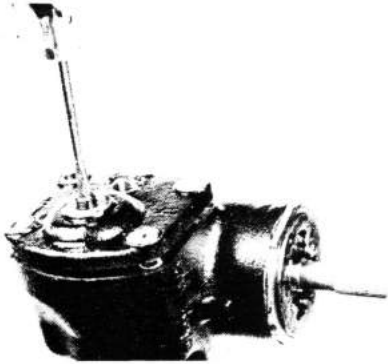

Screw in the bolt to remove the cover.

Fig. 8-153

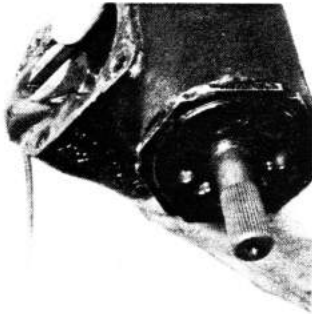

Pour out the remaining oil before removing the sector shaft.

Fig. 8-154

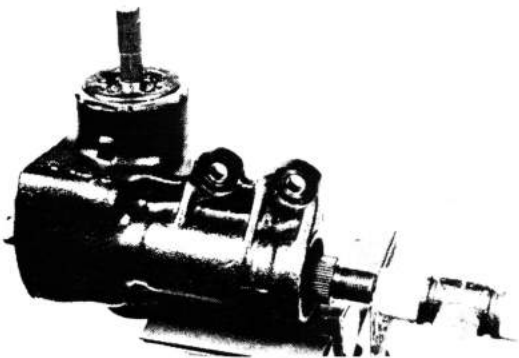

Remove the sector shaft by tapping the bottom end with a plastic hammer.

Fig. 8-155

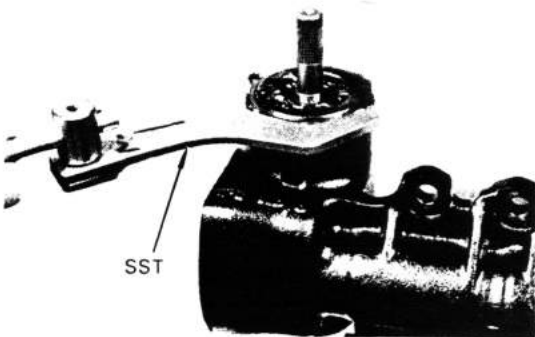

Loosen the lock nut with SST.
SST [09617-22010]

Fig. 8-156

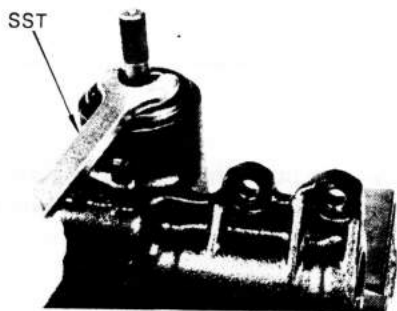

Remove the bearing adjusting screw with SST. SST [09616-22010]

Fig. 8-157

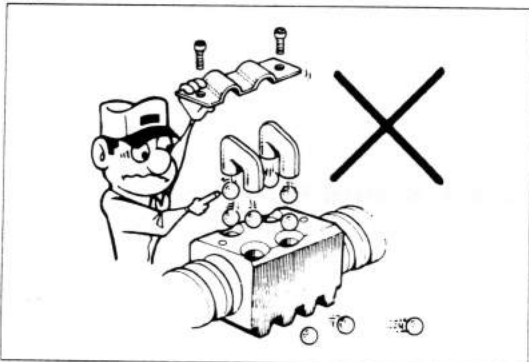

— Note —
Do not disassemble the ball nut from steering main shaft.

Fig. 8-158



INSPECTION & REPAIR

Worm & Nut

Inspect the worm and nut for wear or damage.

Fig. 8-159



Check the turning condition of nut.

— Note —

It should revolve smoothly by own weight.

Fig. 8-160

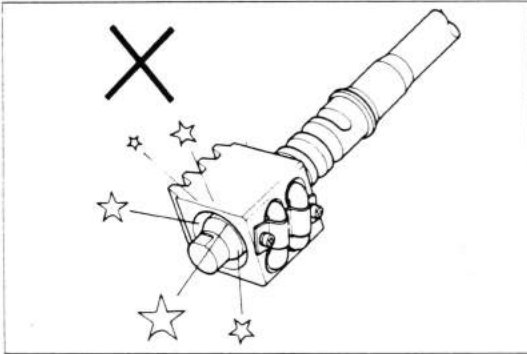

— Note —
To prevent ball damage, do not strike the ball nut against the ends of the worm.

Fig. 8-161

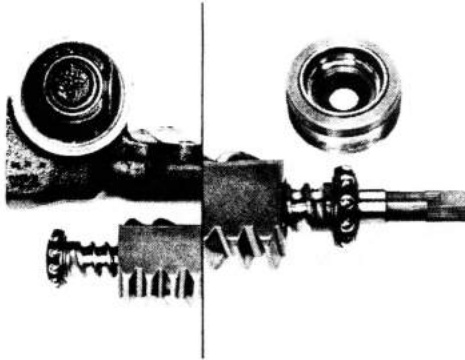

Worm Bearing Race
Inspect the worm bearing for wear or damage.

Fig. 8-162

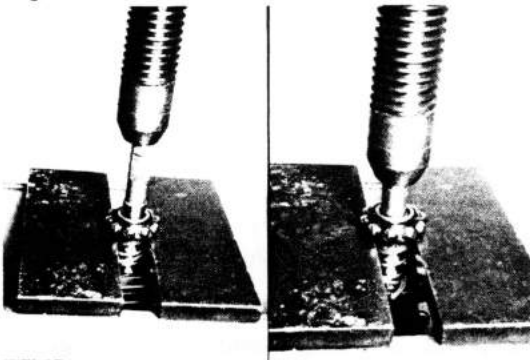

Replace The Worm Bearing

1. Remove the worm bearing.

Fig. 8-163

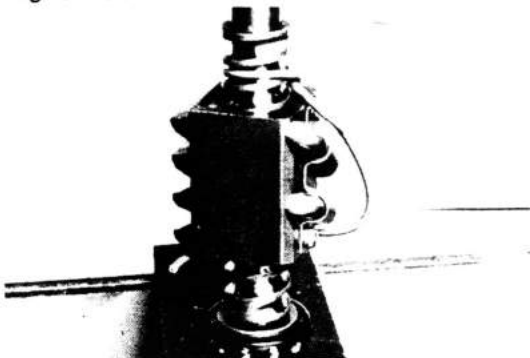

2. Install the worm bearing.

Fig. 8-164



3. Install the worm bearing.

Fig. 8-165

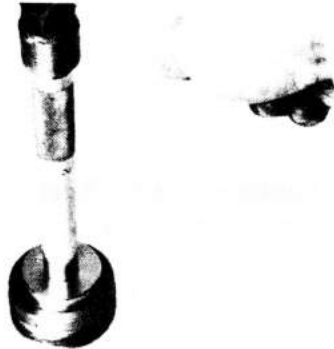

4. Replace the outer race.

Fig. 8-166

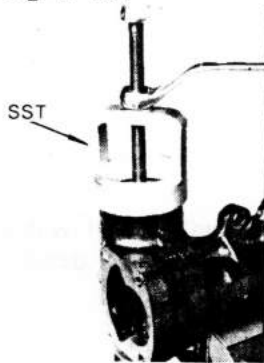

5. Remove the bearing outer race from the gear housing with SST.
SST [09612-65013]

— Note —
Align the claw on the SST with the depression in the housing.

Fig. 8-167

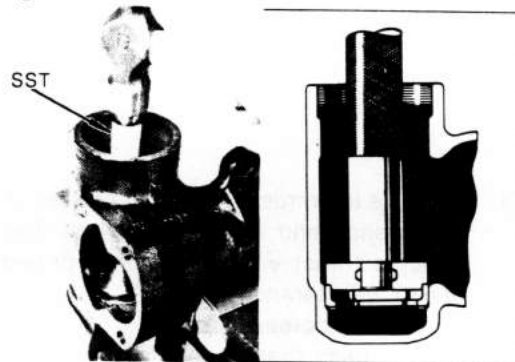

6. Install the bearing outer race with SST.
SST [09608-35013]

Fig. 8-168



Sector Shaft Oil Seal

Check for wear or damage.

Fig. 8-169



Replace The Oil Seal

Replace the oil seal.



Fig. 8-170



Sector Shaft

1. Inspect the sector shaft, thrust washer and adjusting screw for wear or damage.

Fig. 8-171

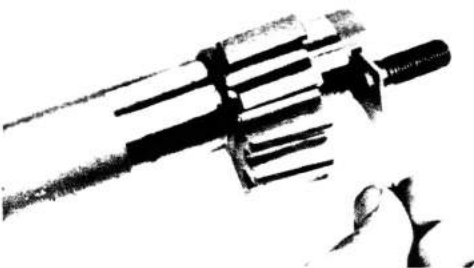

3. Measure the thrust clearance between the sector shaft and the adjusting bolt. Then select a thrust washer that will provide minimum clearance.

Thrust clearance:

Less than **0.05 mm**
(0.0020 in.)

Thrust washer thickness mm (in.)

2.00 (0.0787)	2.15 (0.0846)
2.05 (0.0807)	2.20 (0.0866)
2.10 (0.0827)	

Fig. 8-172

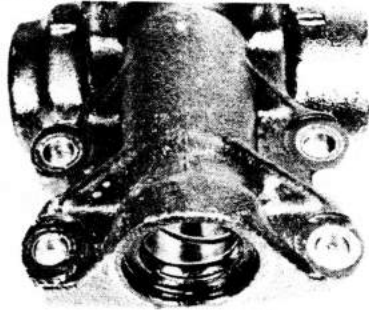

Bushing

1. Inspect for wear or damage.

Fig. 8-173

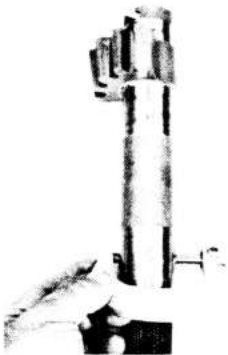

2. Check the oil clearance.

Oil clearance:

STD 0.009–0.060 mm
(0.0004–0.0024 in.)

Limit 0.10 mm
(0.0039 in.)

Fig. 8-174

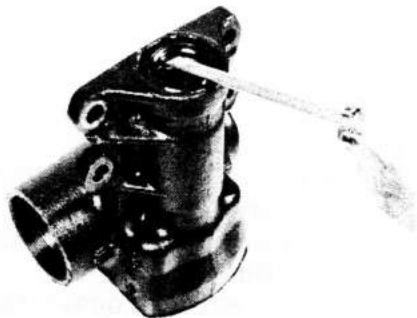

Replace The Bushing

1. Remove the oil seal.

Fig. 8-175

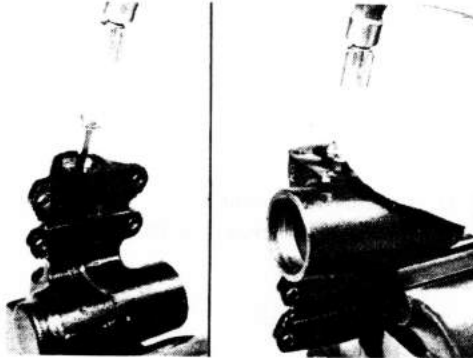

2. Remove the two bushings.

Fig. 8-176

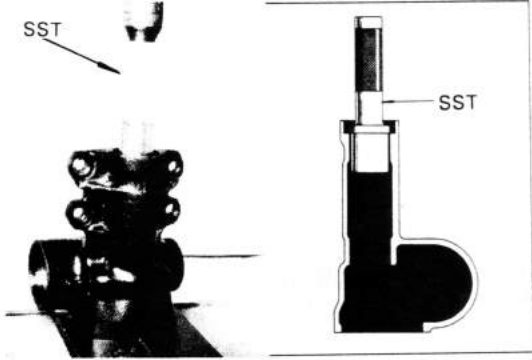

3. Install the outer bushing with SST.
SST [09615-37010]

Fig. 8-177

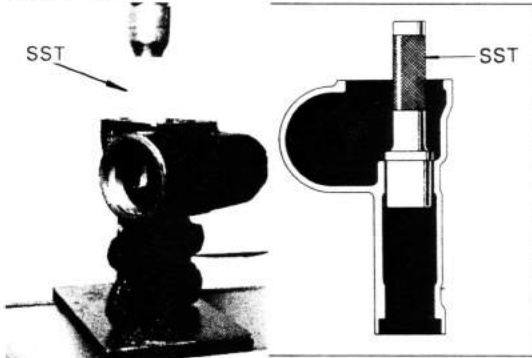

4. Install the inner bushing with SST.
SST [09615-37010]

Fig. 8-178

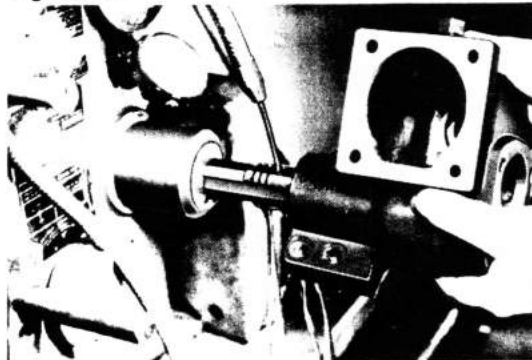

- 5.hone the inner surface of the bushings until standard oil clearance is obtained between the bushings and sector shaft.

Oil clearance:

STD 0.009–0.060 mm
(0.0004–0.0024 in.)

Fig. 8-179



6. Install a new oil seal.
Apply MP grease to the lip.

Fig. 8-180



Gear Housing

Inspect for damage or cracks.

Fig. 8-181



Sector Shaft End Cover

1. Inspect for wear or damage.

Fig. 8-182

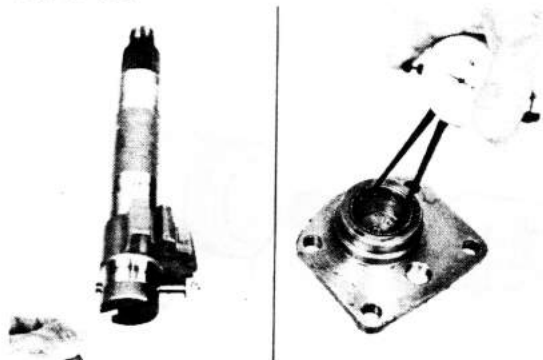

2. Check the oil clearance.

Oil clearance:

STD 0.009–0.060 mm
(0.0004–0.0024 in.)

Limit 0.10 mm
(0.0039 in.)

ASSEMBLY

Assemble the parts in the numerical order shown in the figure.

Fig. 8-183

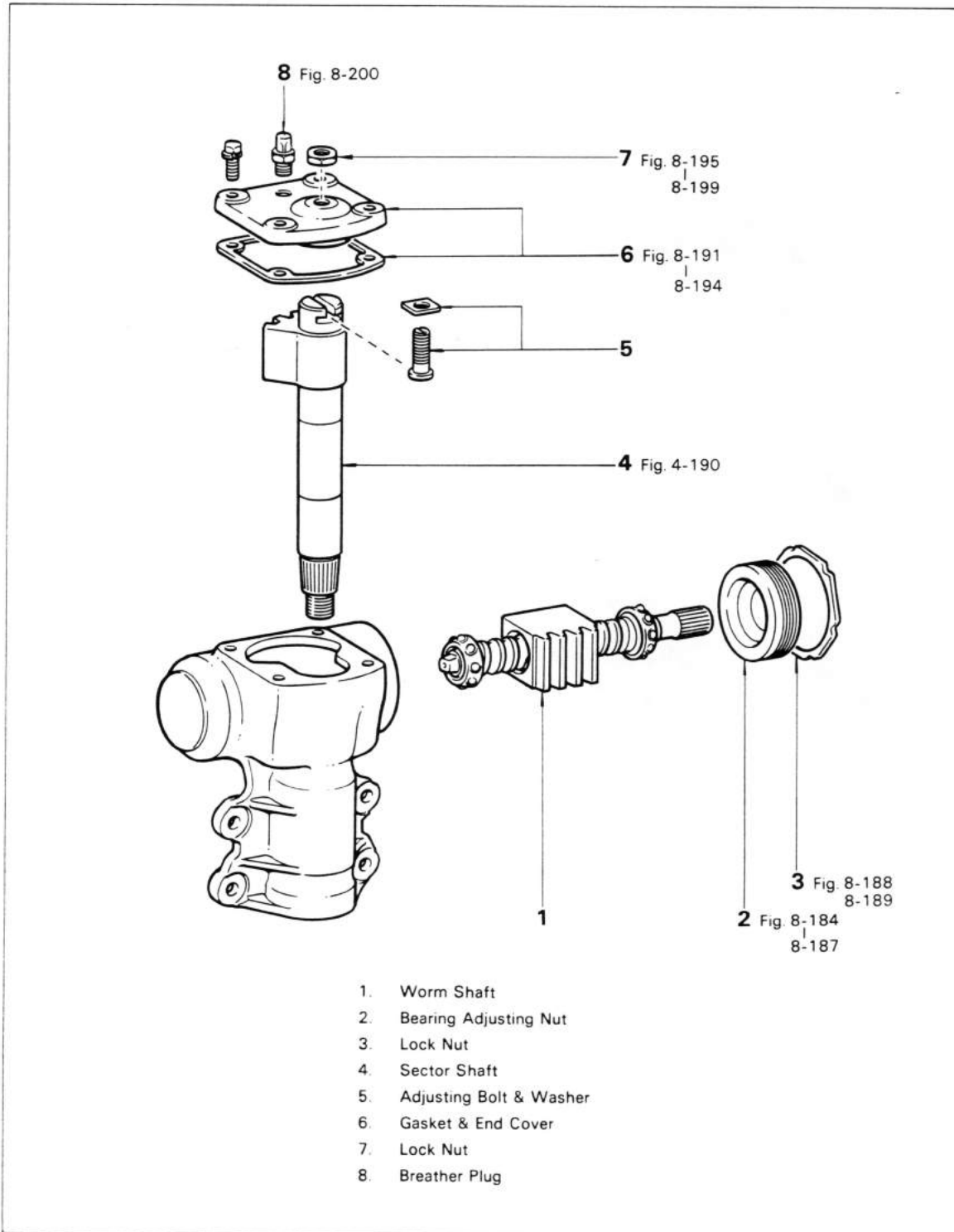

Fig. 8-184



Before starting assembly, apply MP grease to bushing.
Coat the oil seal with MP grease.

Fig. 8-185



When inserting the shaft through the adjusting nut, be careful not to damage the oil seal lip.

Fig. 8-186



Assemble the bearing adjusting screw, then adjust the bearing preload by gradually tightening the screw with SST.
SST [09616-22010]

— Note —

Before adjusting the preload, tighten the screw to snug down the bearing.

Fig. 8-187

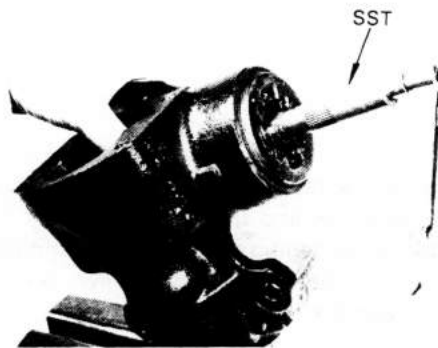

Measure the bearing preload with SST and a torque meter.
SST [09616-00010]

Preload (starting): 3.5–6.5 kg-cm
(3.0–5.6 in.-lb)

— Note —

Check to see that both the right and left rotations are identical.

Fig. 8-188

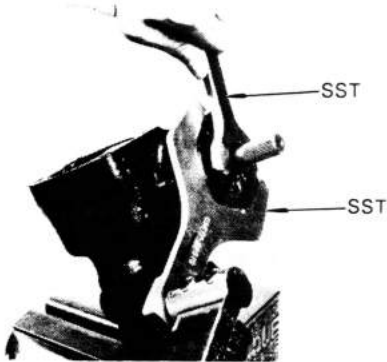

Tighten the lock nut with SST.

SST [09616-22010]

[09617-22010]

**Tightening torque: 23.0–26.0 kg-m
(167–188 ft-lb)**

Fig. 8-189

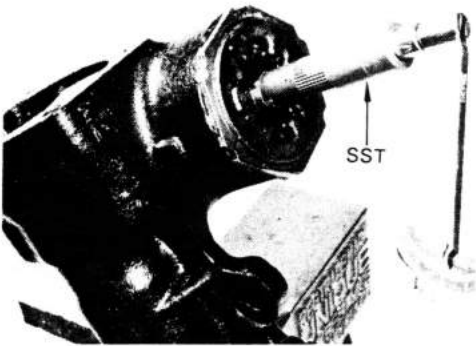

After tightening the lock nut, make sure that the bearing preload has not changed.

SST [09616-00010]

Fig. 8-190

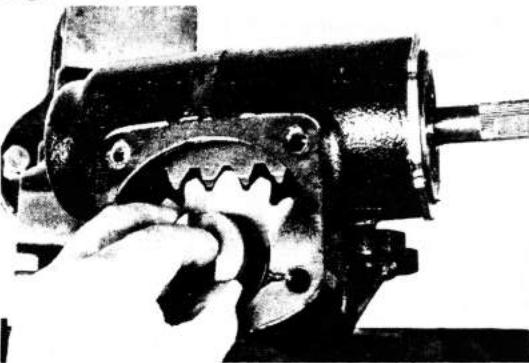

Set the ball nut at center of the worm and insert the sector shaft into gear housing.

– Note –

Insure that the center teeth of the ball nut and sector shaft are meshing.

Fig. 8-191



Assemble the sector shaft end cover with the adjusting screw and thrust washer.

1. Before tightening the set bolts, completely loosen the adjusting screw with a screwdriver.

Fig. 8-192

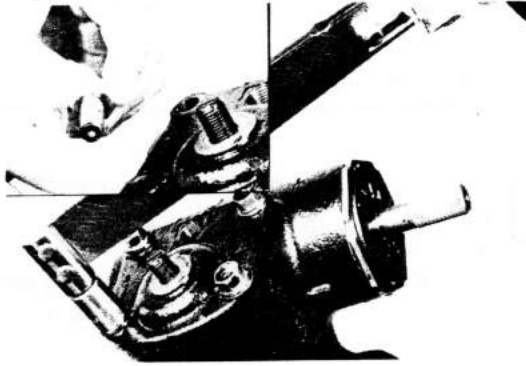

2. Coat the sealer on the thread and tighten the bolts.

Tightening torque:

**4.5 – 5.5 kg-m
(33 – 39 ft-lb)**

Fig. 8-193

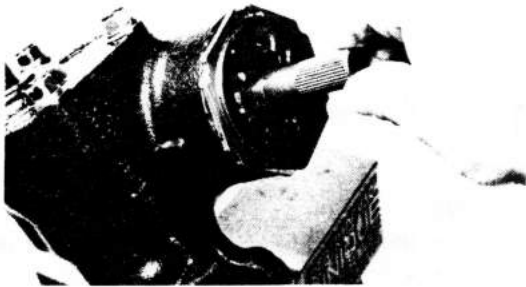

- Set in the neutral position of the worm shaft and place matchmarks on the worm shaft.

– Note –

Count the total number of worm shaft rotations and turn back half of the total number from one end to determine the neutral position.

Fig. 8-194



- Adjust the overall preload with the adjusting screw at the neutral position. Measure the preload with SST.

SST [09616-00010]

**Preload (starting): 8 – 11 kg-cm
(6.9 – 9.5 in.-lb)**

– Note –

Preload measurement should be made with the meshing in the center (neutral) position.

Fig. 8-195

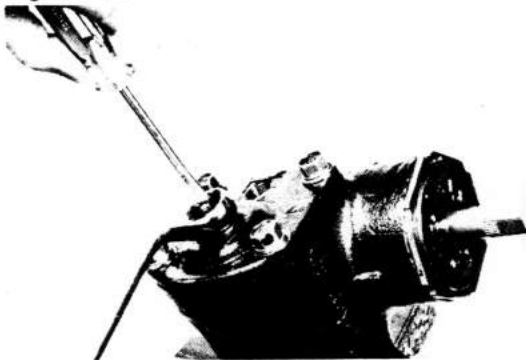

- Tighten the lock nut.

**Tightening torque: 3.0 – 4.0 kg-m
(22 – 28 ft-lb)**

cardiagn.com

Fig. 8-196

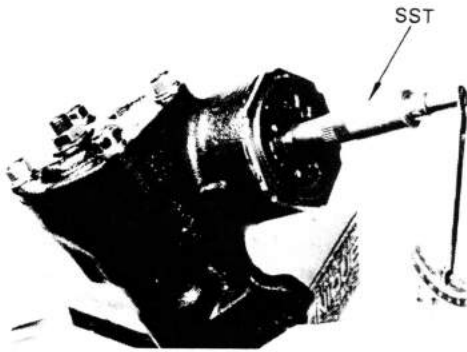

After tightening the lock nut, reconfirm the preload.

SST [09616-00010]

**Preload (starting): 8 – 11 kg-cm
(6.9 – 9.5 in.-lb)**

Fig. 8-197

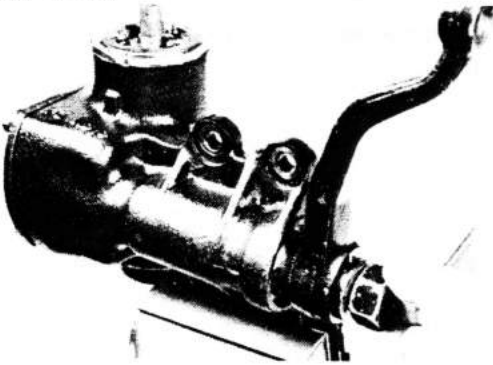

Install the pitman arm and slightly tighten the nut.

– Note –

Align the matchmarks on the pitman arm and sector shaft.

Fig. 8-198

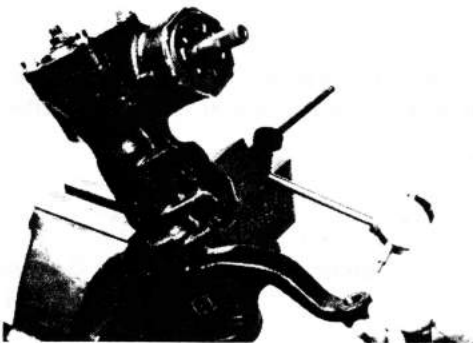

Measure the sector shaft backlash.

– Note –

Sector shaft should have no backlash within 100 degrees on the left and right side of neutral position.

Fig. 8-199

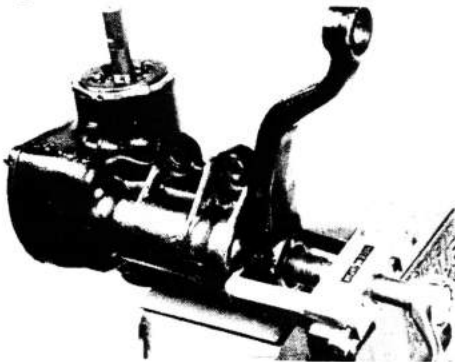

After checking the backlash, remove the pitman arm

Fig. 8-200

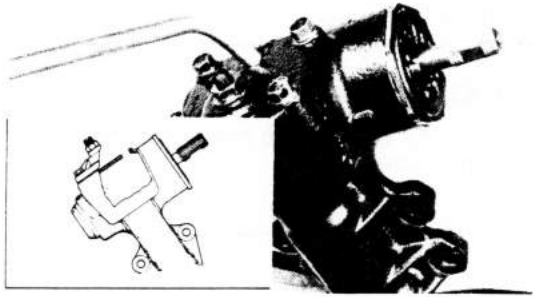

Replenish with gear oil.

Capacity: 500 cc
(30.5 cu in.)

Oil level:
API GL-5, SAE 90

INSTALLATION

Install the parts in the numerical order shown in the figure.

Fig. 8-201

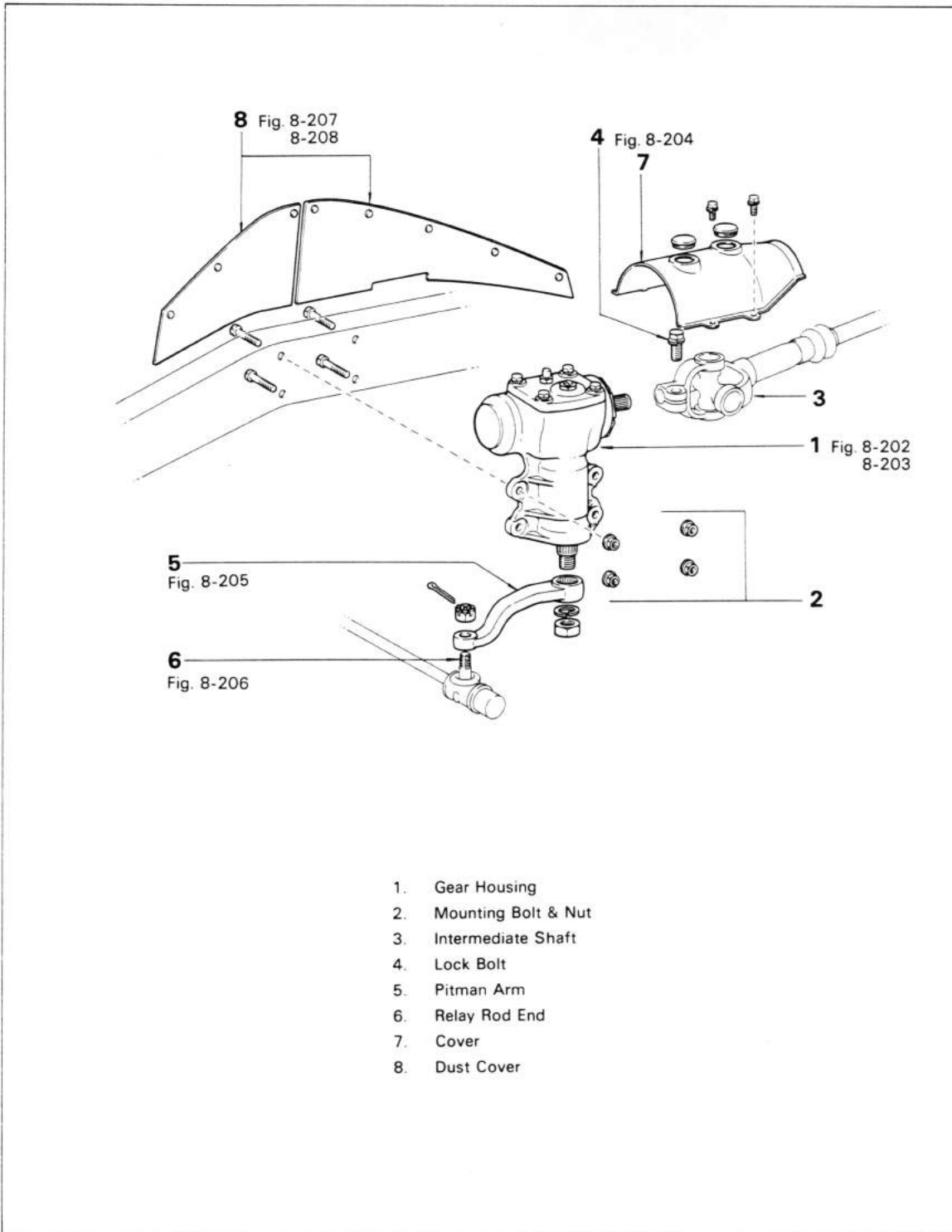

1. Gear Housing
2. Mounting Bolt & Nut
3. Intermediate Shaft
4. Lock Bolt
5. Pitman Arm
6. Relay Rod End
7. Cover
8. Dust Cover

Fig. 8-202

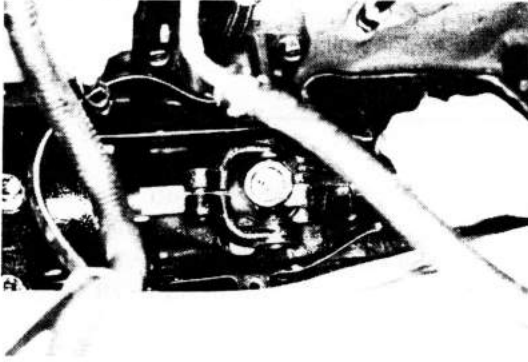

Align the slit on yoke to the shaft groove.

Fig. 8-203

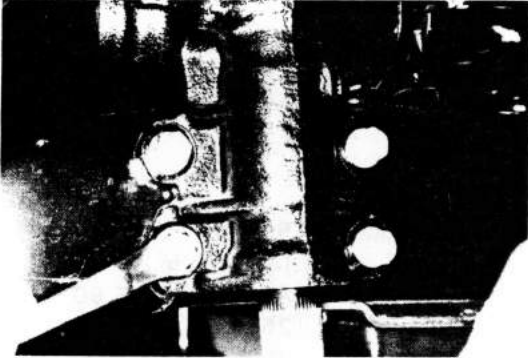

Tighten the gear housing set bolts.

Tightening torque: 5.5 – 8.8 kg-m
(40 – 63 ft-lb)

Fig. 8-204



Tighten the coupling bolt.

Tightening torque: 3.0 – 4.5 kg-m
(22 – 32 ft-lb)

Fig. 8-205

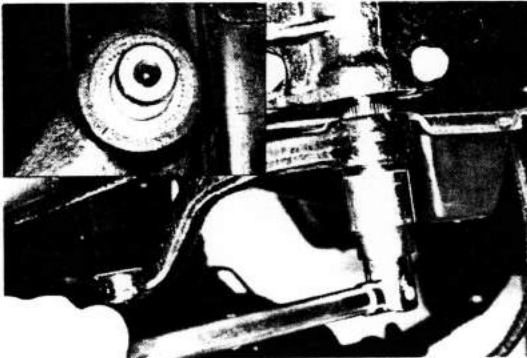

Align the matchmarks on the pitman arm and tighten the nut.

Tightening torque:
16.5 – 19.5 kg-m
(120 – 141 ft-lb)

Fig. 8-206

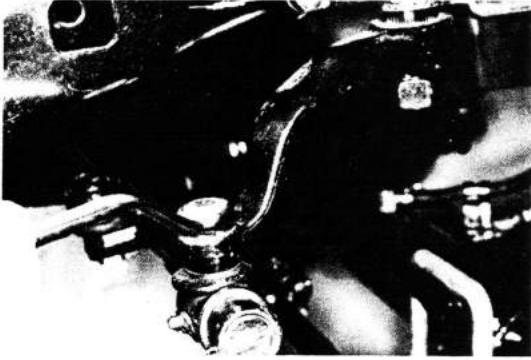

Connect the pitman arm to the steering linkage and install a new cotter pin.

Tightening torque: 7.5–11.0 kg-m
(55–79 ft-lb)

Fig. 8-207

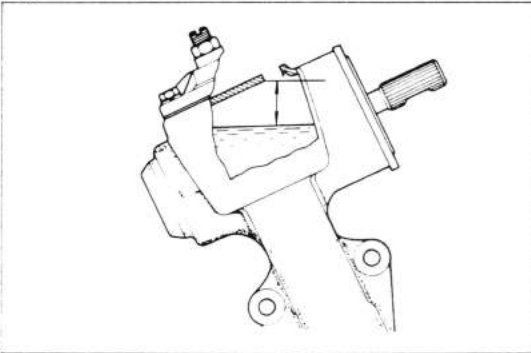

Fill with gear oil.

Capacity: 500 cc
(30.5 cu in.)
API GL-5, SAE 90

Oil level: 25 – 28 mm
(0.98 – 1.02 in.)

Fig. 8-208

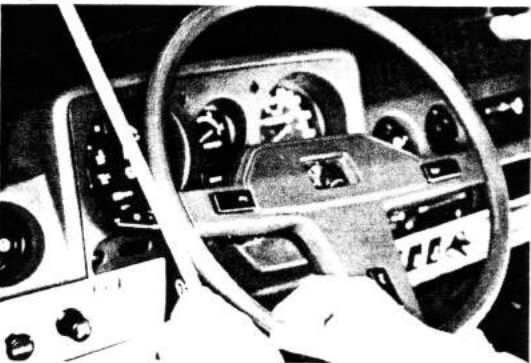

Check the steering wheel play at the neutral position.

Steering wheel play:
Less than 30 mm
(1.18 in.)

STEERING GEAR HOUSING (FJ, BJ, HJ4 — SERIES)

REMOVAL

Remove the parts in the numerical order shown in the figure.

Fig. 8-209

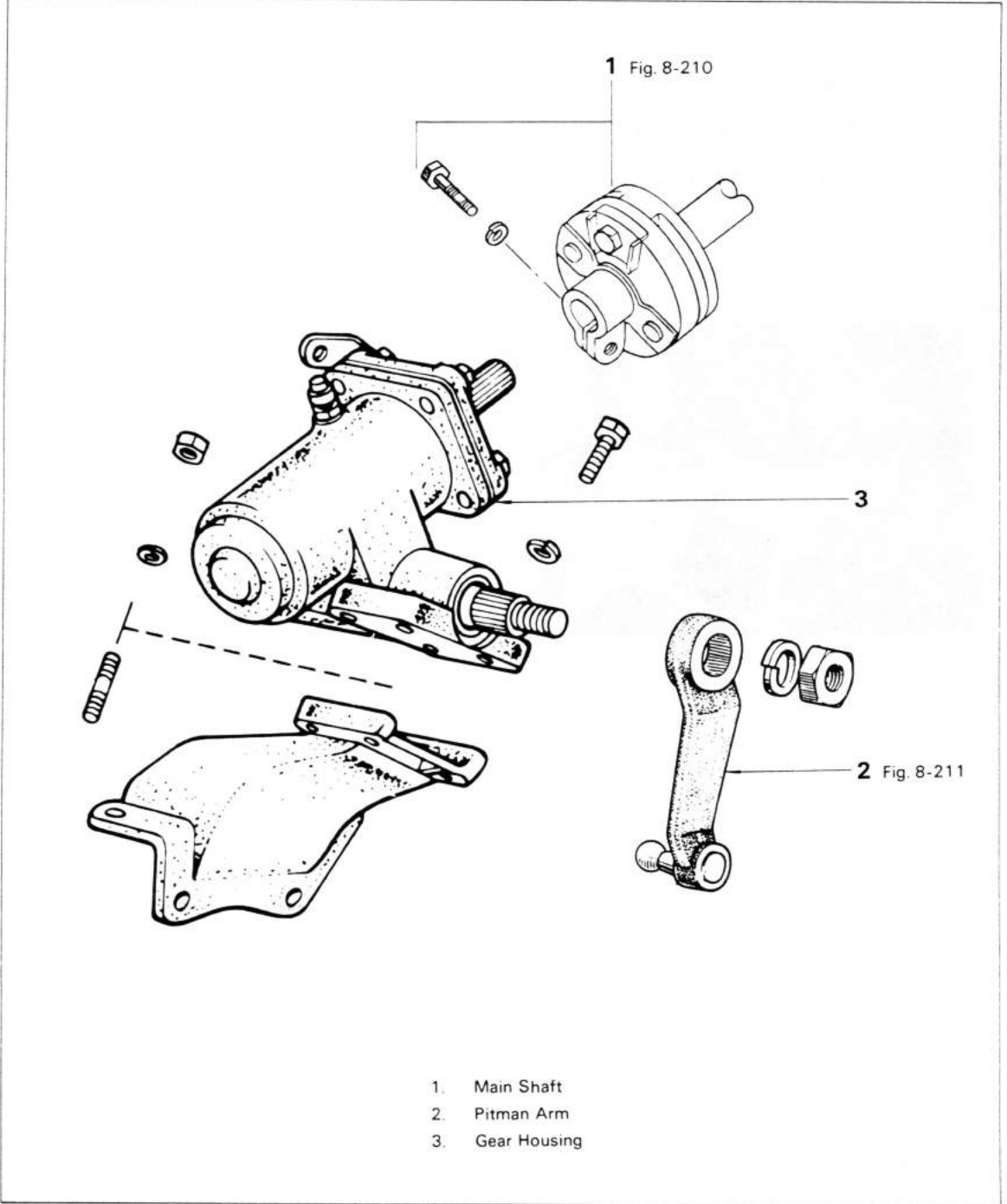
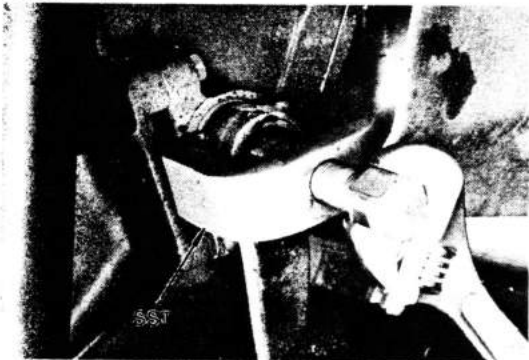

Fig. 8-210

SEE
STEERING COLUMN &
MAIN SHAFT REMOVAL SECTION
Fig. 8-140 to 8-142

Remove the steering wheel and main shaft.

Fig. 8-211



Remove the pitman arm with SST.
SST [09610-55012]

DISASSEMBLY

Disassemble the parts in the numerical order shown in the figure.

Fig. 8-212

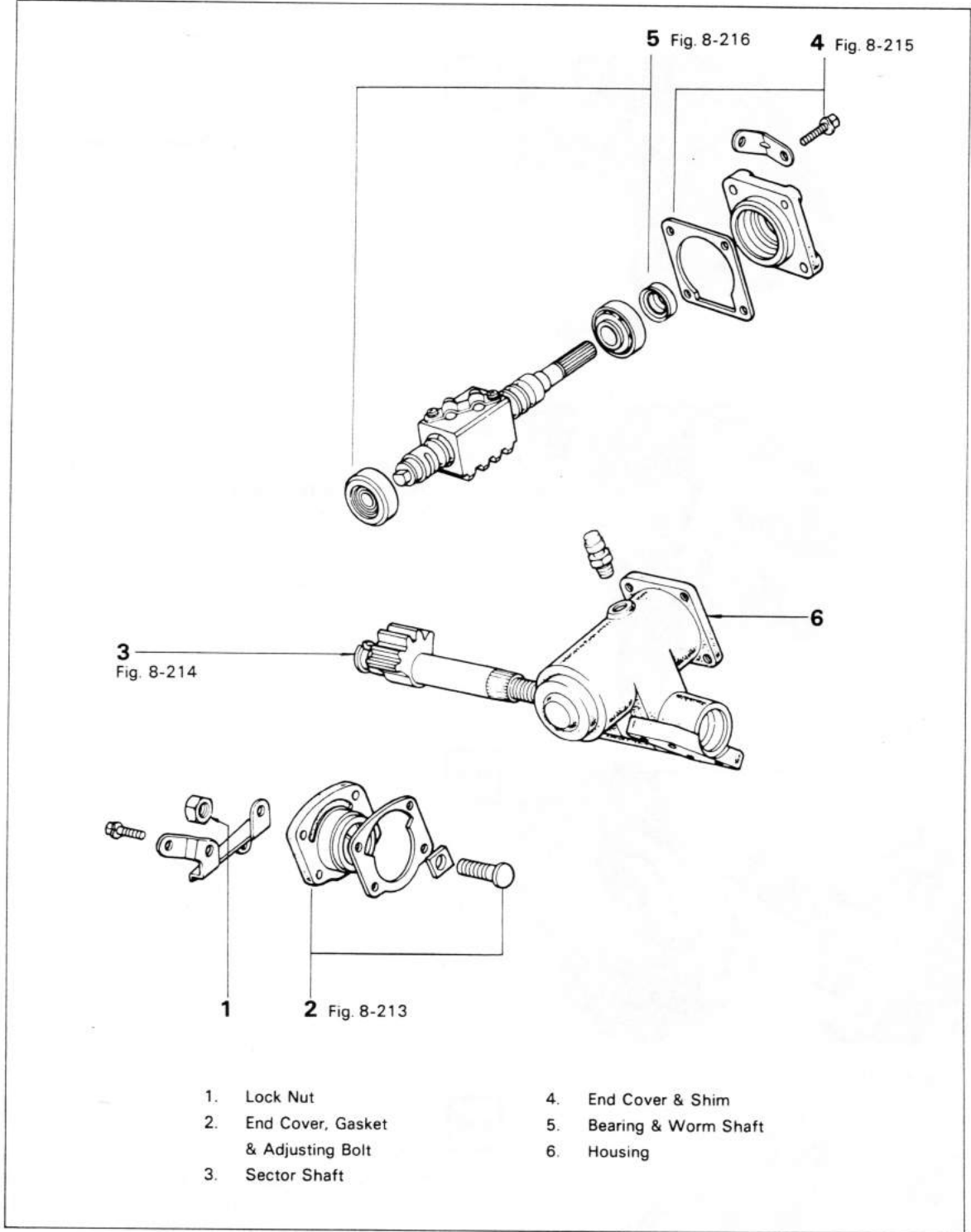
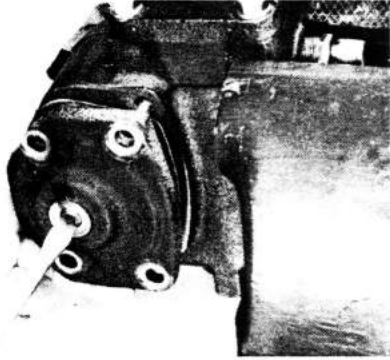

Fig. 8-213



Screw in the bolt and remove the cover.

— Note —

Use a receiver to catch the oil from the gear housing.

Fig. 8-214

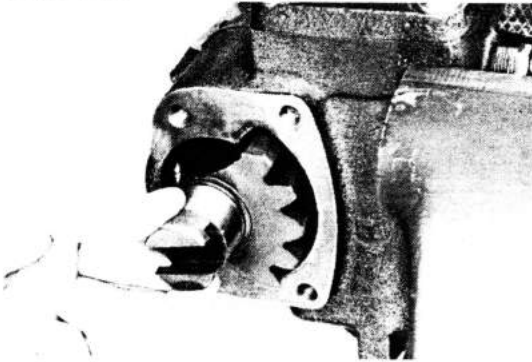

Pull the sector shaft out of the housing.

— Caution —

Have the sector shaft positioned at its rotational center.

Fig. 8-215

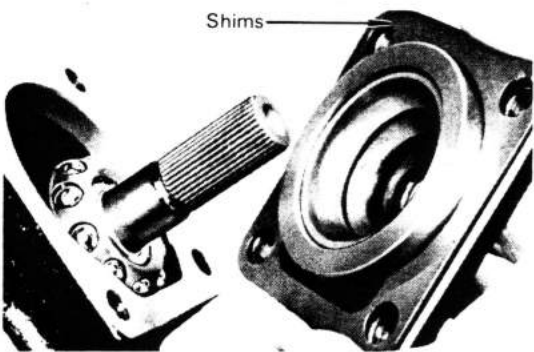

Record the number of shims used.

Fig. 8-216



Remove the worm assembly.

— Note —

1. Keep the bearings in proper order so that they can be reassembled to their initial positions.
2. Do not attempt to disassemble the steering worm assembly. If any part of it is defective, replace the entire assembly.
3. Do not run the ball nut to the worm end.

Fig. 8-217

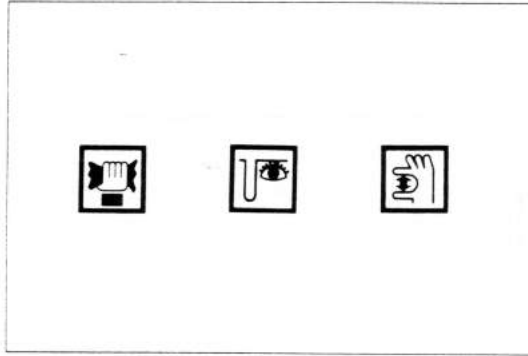

INSPECTION

Wash the disassembled parts and inspect them on the following points.
Replace any part found defective.

Fig. 8-218

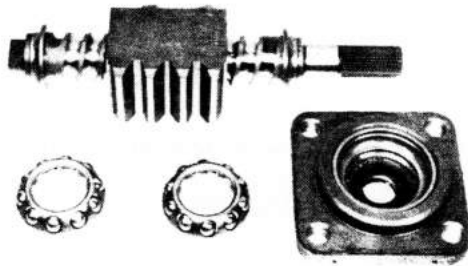

Steering Worm & Bearing

1. Inspect the bearings for wear or damage.
2. Inspect the worm threads and ball nut rack for or wear damage.
3. Check the turning condition of the ball nut.

Fig. 8-219

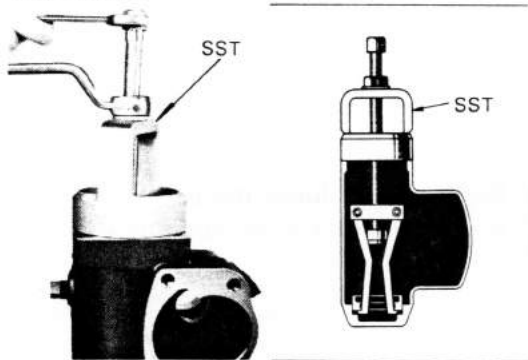

Replace The Worm Bearing Outer Race

1. Remove the outer race at housing end with SST.
SST [09612-65013]

Fig. 8-220

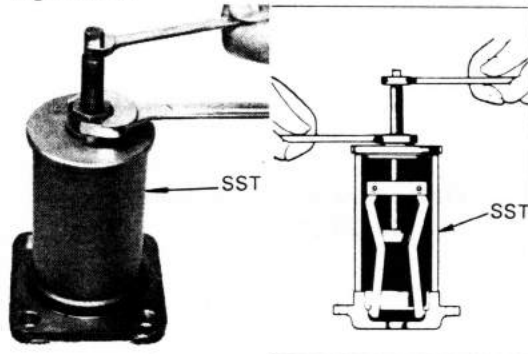

2. Remove the outer race at end cover end with SST.
SST [09612-30012]

Fig. 8-221

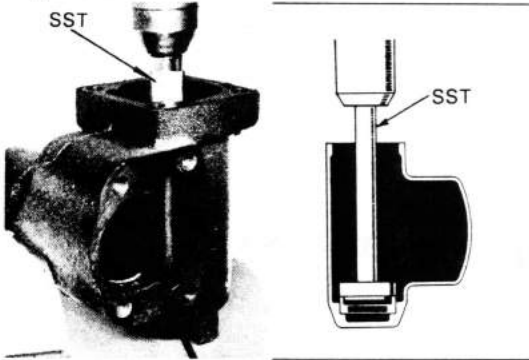

3. Install the outer race at housing end with SST.
SST [09608-35013]

Fig. 8-222

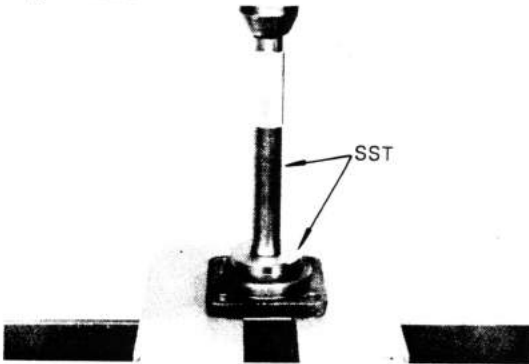

4. Install the outer race at end cover end with SST.
SST [09608-35013]

Fig. 8-223

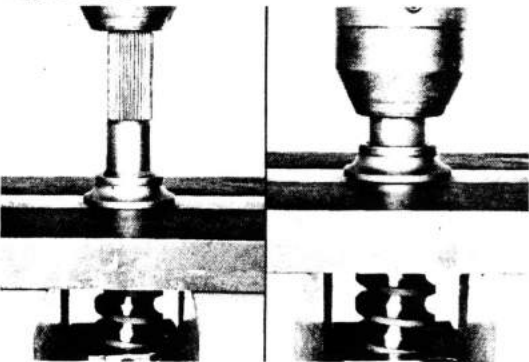

Replace The Inner Race

1. Force out the inner race with a press.

Fig. 8-224

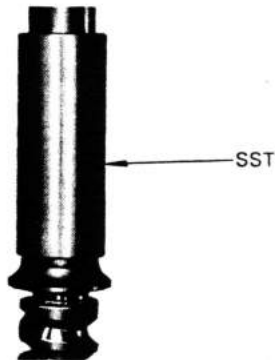

2. Press in the inner race, using SST.
SST [09620-30010]

Fig. 8-225

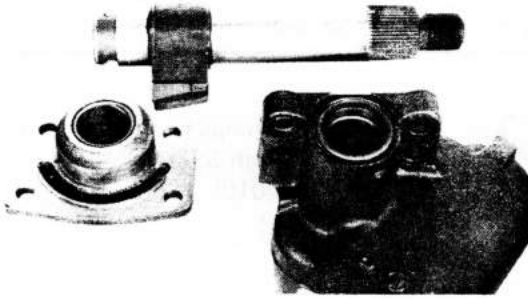

Sector Shaft & Bushing

1. Inspect the shaft at bushing contacting surfaces and at gear teeth for wear or damage.
Inspect the bushings for wear or damage.

Fig. 8-226

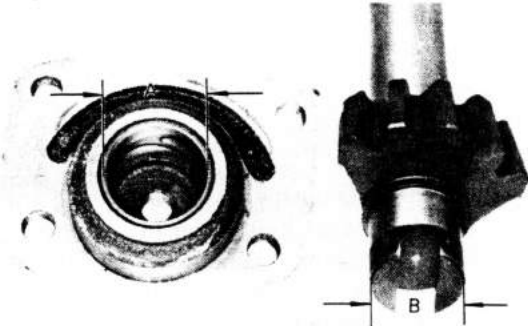

2. Check the sector shaft oil clearance (A — B).

Oil clearance:
Limit 0.1 mm
(0.004 in.)

Fig. 8-227

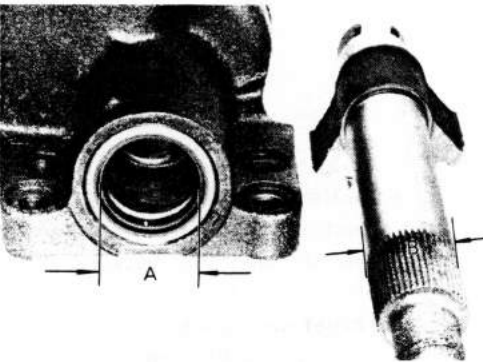

3. Check the sector shaft oil clearance (A — B).

Oil clearance:
Limit 0.1 mm
(0.004 in.)

Fig. 8-228

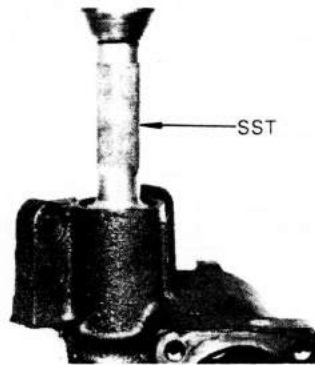

Replace The Gear Housing

1. Remove the oil seal.
2. Press out the two bushings at the same time in the same direction with SST.
SST [09307-12010]

Fig. 8-229

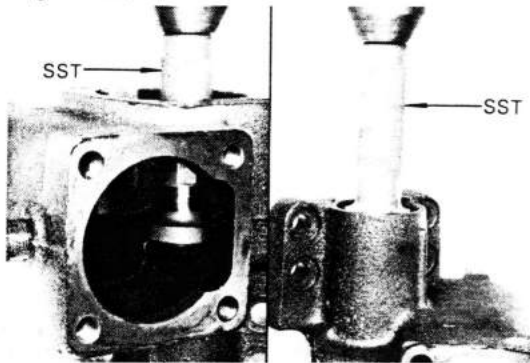

3. Press in the bushings from each end of the gear housing with SST.
SST [09307-12010]

Fig. 8-230

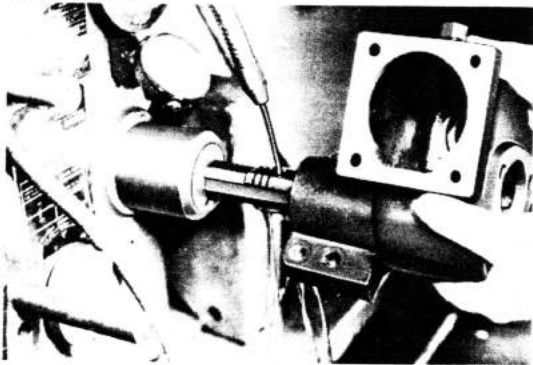

- 4.hone the bushings with a pin hole grinder or similar means until standard oil clearance is obtained between the bushings and the sector shaft.

Oil clearance:

STD 0.009 – 0.060 mm
(0.0004 – 0.0024 in.)

5. Install the oil seal.

Fig. 8-231

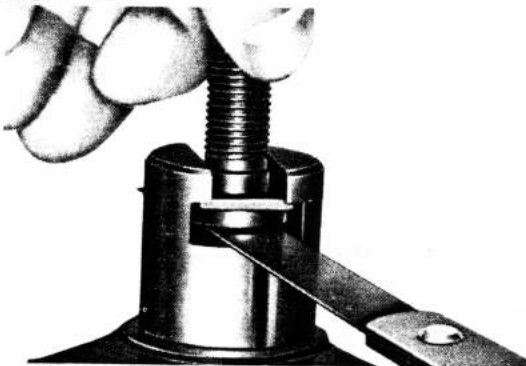

6. Measure the sector shaft thrust clearance, and select a thrust washer that will provide minimum clearance between the sector shaft and the adjusting screw.

Thrust clearance

Limit 0.05 mm
(0.0020 in.)

Thrust washer thickness mm (in.)

Part No.	Mark	Thickness
45352-36010	1	2.00 (0.0787)
45353-36010	2	2.05 (0.0807)
45354-36010	3	2.10 (0.0827)
45355-36010	4	2.15 (0.0846)
45356-36010	5	2.20 (0.0866)

ASSEMBLY

Assemble the parts in the numerical order shown in the figure.

Fig. 8-232

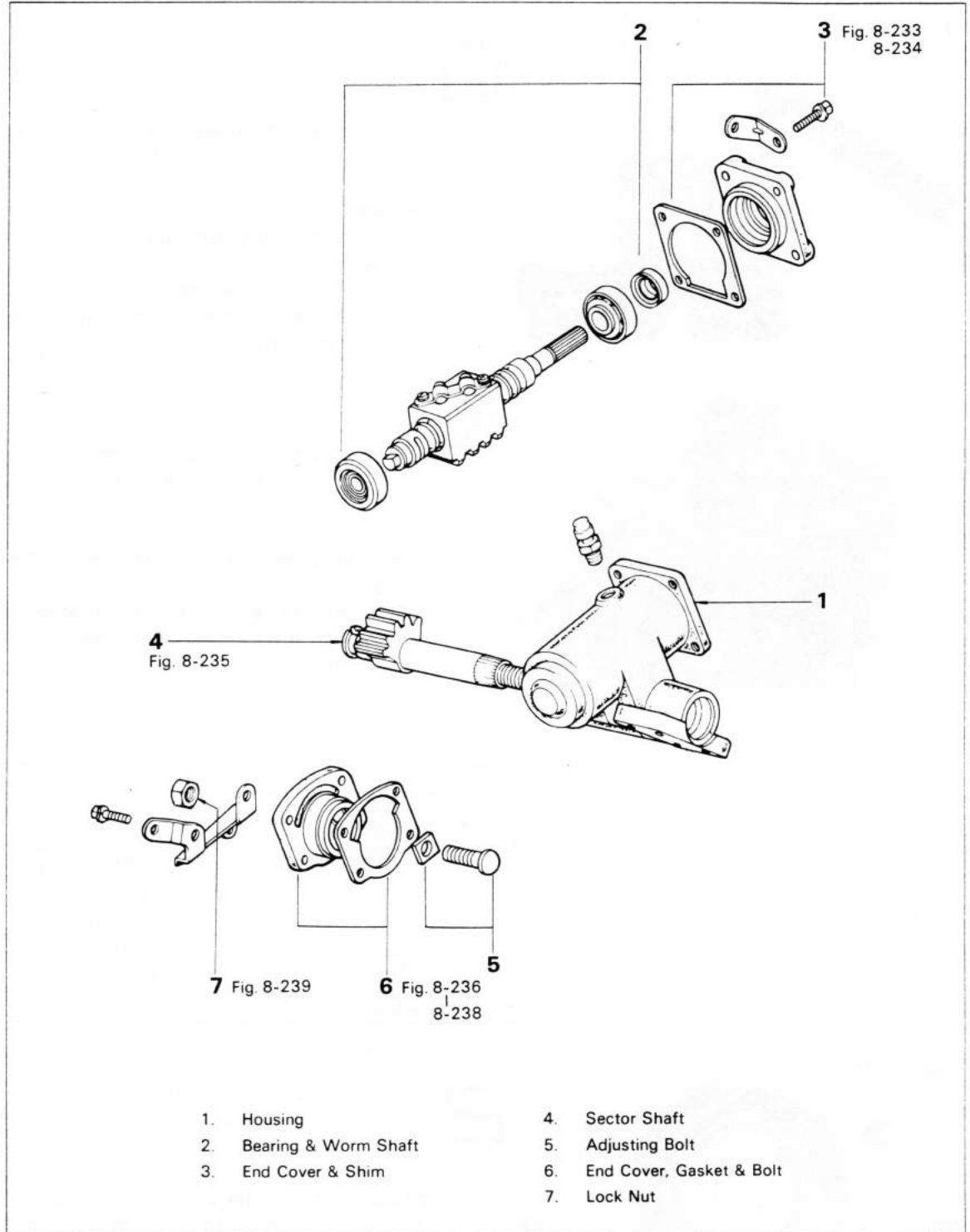

cardiagn.com

Fig. 8-233

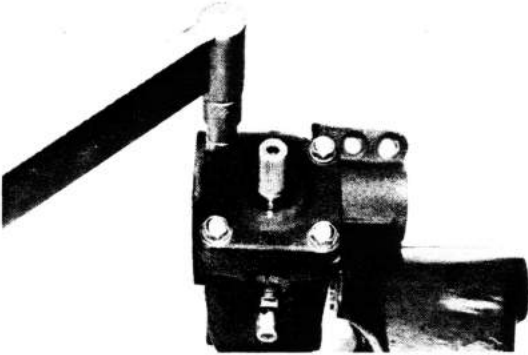

Install the cover over the same amount of shims removed at disassembly, and tighten the cover bolts at specified torque.

**Tightening torque: 3.0 – 4.5 kg-m
(22 – 32 ft-lb)**

– Note –

1. Have the worm bearing lubricated with gear oil.
2. While tightening the cover bolts, keep checking the worm to see that it will turn properly.

Fig. 8-234

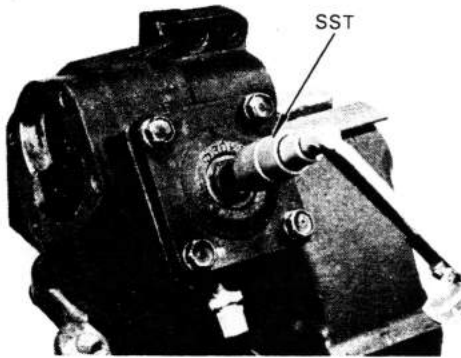

Measure the worm bearing preload.
SST [09616-00010]

**Preload: 3.5 – 6.5 kg-cm
(3.0 – 5.6 in.-lb)**

– Note –

Read the scale just when the worm starts to turn.

If the preload is not within the specified limits, correct by selecting proper thickness shim.

Shim thickness mm (in.)

Part No.	Mark	Thickness
45323-36010	1	0.05 (0.0020)
45323-36020	2	0.07 (0.0028)
45323-36030	3	0.08 (0.0031)
45323-36040	4	0.10 (0.0039)
45323-36050	5	0.20 (0.0079)
45323-36060	6	0.50 (0.0197)
45323-36070	7	0.06 (0.0024)
45323-36080	8	0.09 (0.0035)

Fig. 8-235

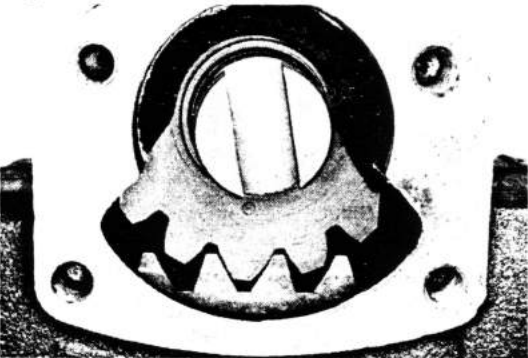

Position the worm ball nut at the center and insert the sector shaft.

– Caution –

Make sure that the worm ball nut and the sector are meshing together at the center.

Fig. 8-236

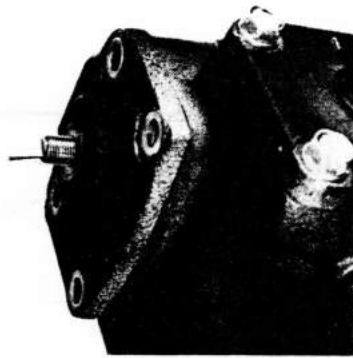

Loosen the adjusting bolt all the way, and install the cover.

Fig. 8-237

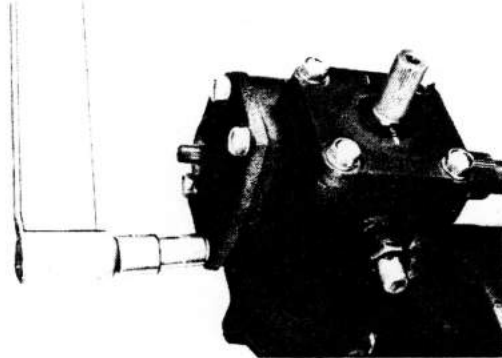

Tighten the cover bolts at the specified torque.

**Tightening torque: 3.0 – 4.5 kg-m
(22 – 32 ft-lb)**

Fig. 8-238

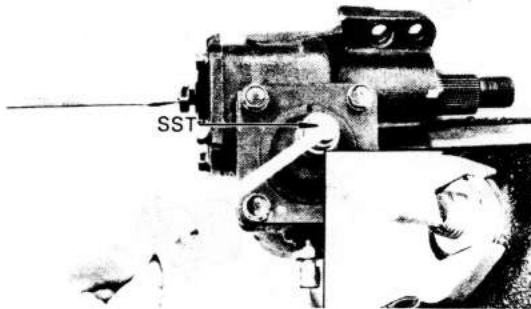

Set the worm shaft preload to the specified value by means of the adjusting bolt.

**Preload: 8.0 – 11.0 kg-cm
(6.9 – 9.5 in.-lb)**

— Note —

Measurement should be made with the meshing positioned at the center.

Fig. 8-239

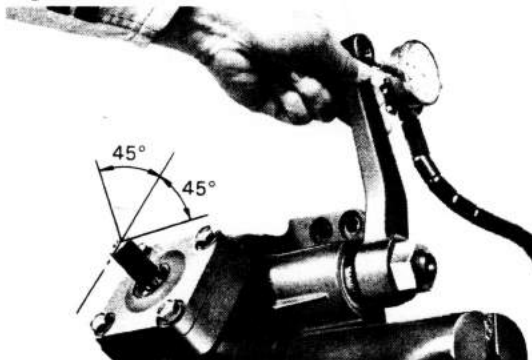

Install the pitman arm and check to see that there is no backlash when the worm is rotated within 45 degrees to either side from center position.

Tighten the adjusting screw lock nut.

— Note —

After tightening, recheck the preload.

INSTALLATION

Install the parts in the numerical order shown in the figure.

Fig. 8-240

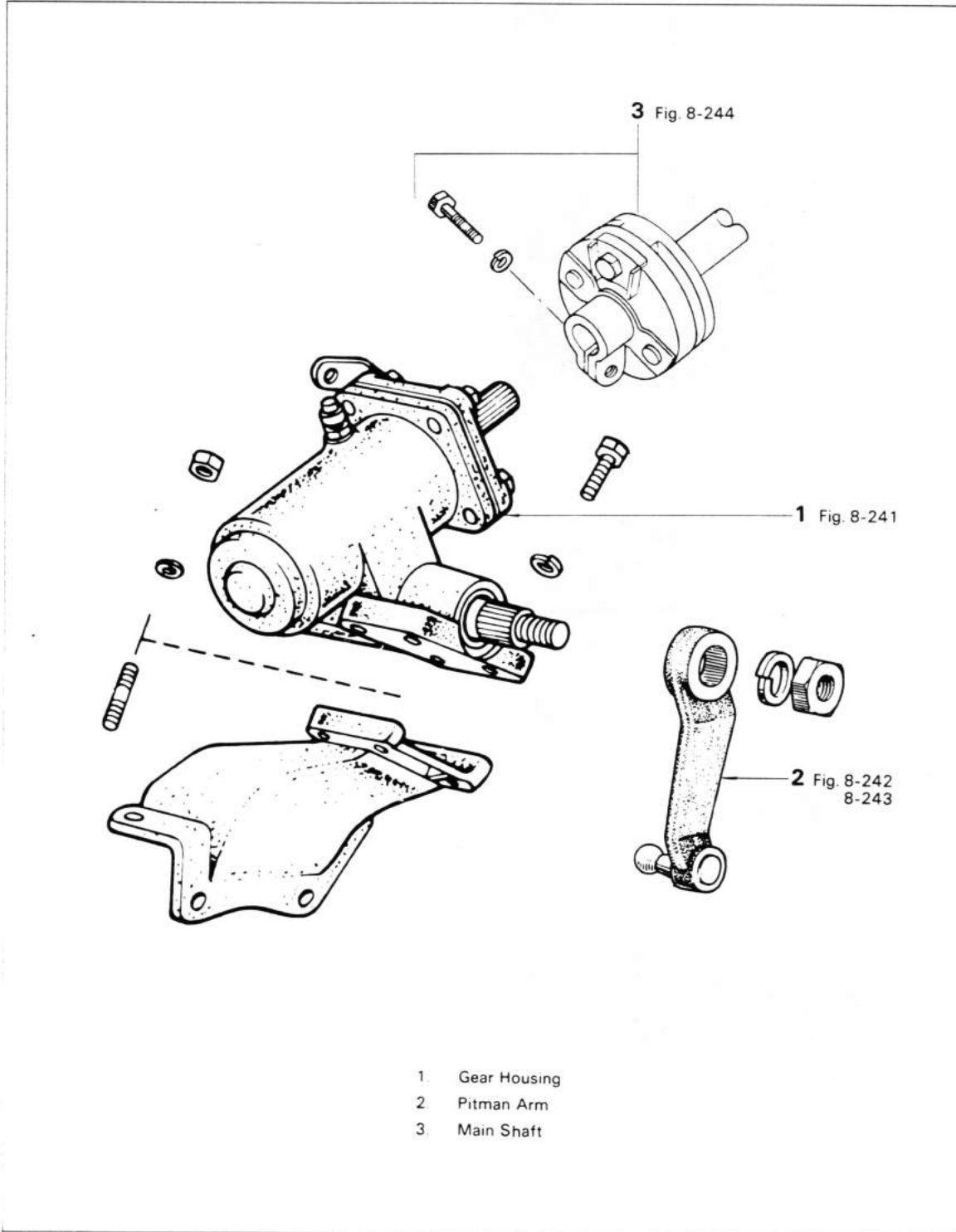
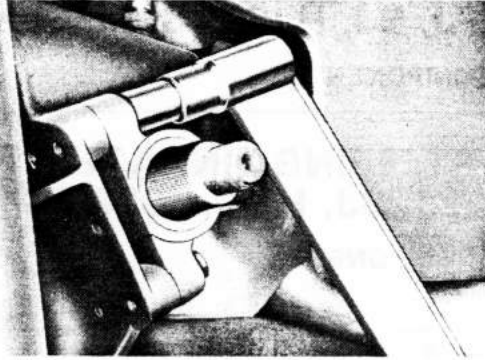

Fig. 8-241



Tighten the bolts and nuts at the specified torque.

Tightening torque: 4.0 – 4.5 kg-m
(29 – 32 ft-lb)

Fig. 8-242

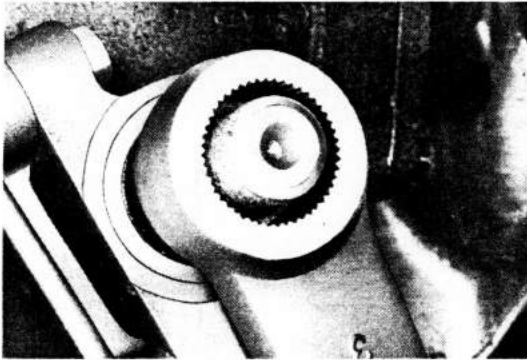

Align the matchmarks on the pitman arm and sector shaft.

Fig. 8-243

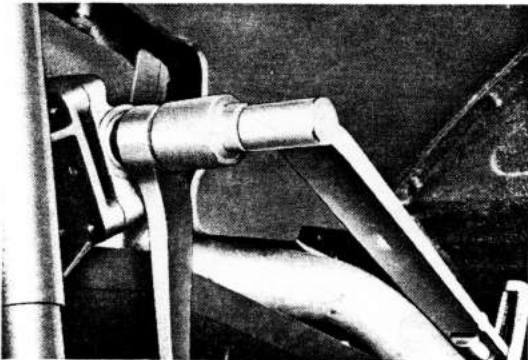

Tighten at specified torque.

Tightening torque: 16.5–19.5 kg-m
(120 – 141 ft-lb)

Fig. 8-244

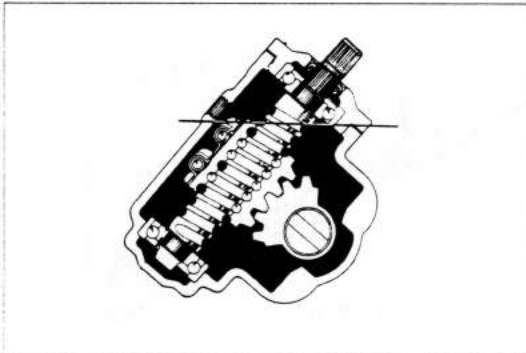

Fill in gear oil.

Capacity:

STD 610 cc
(37.2 cu in.)

Type: SAE 90, API GL-4

STEERING LINKAGE (FJ, BJ, HJ6 — SERIES)

COMPONENTS

Fig. 8-245

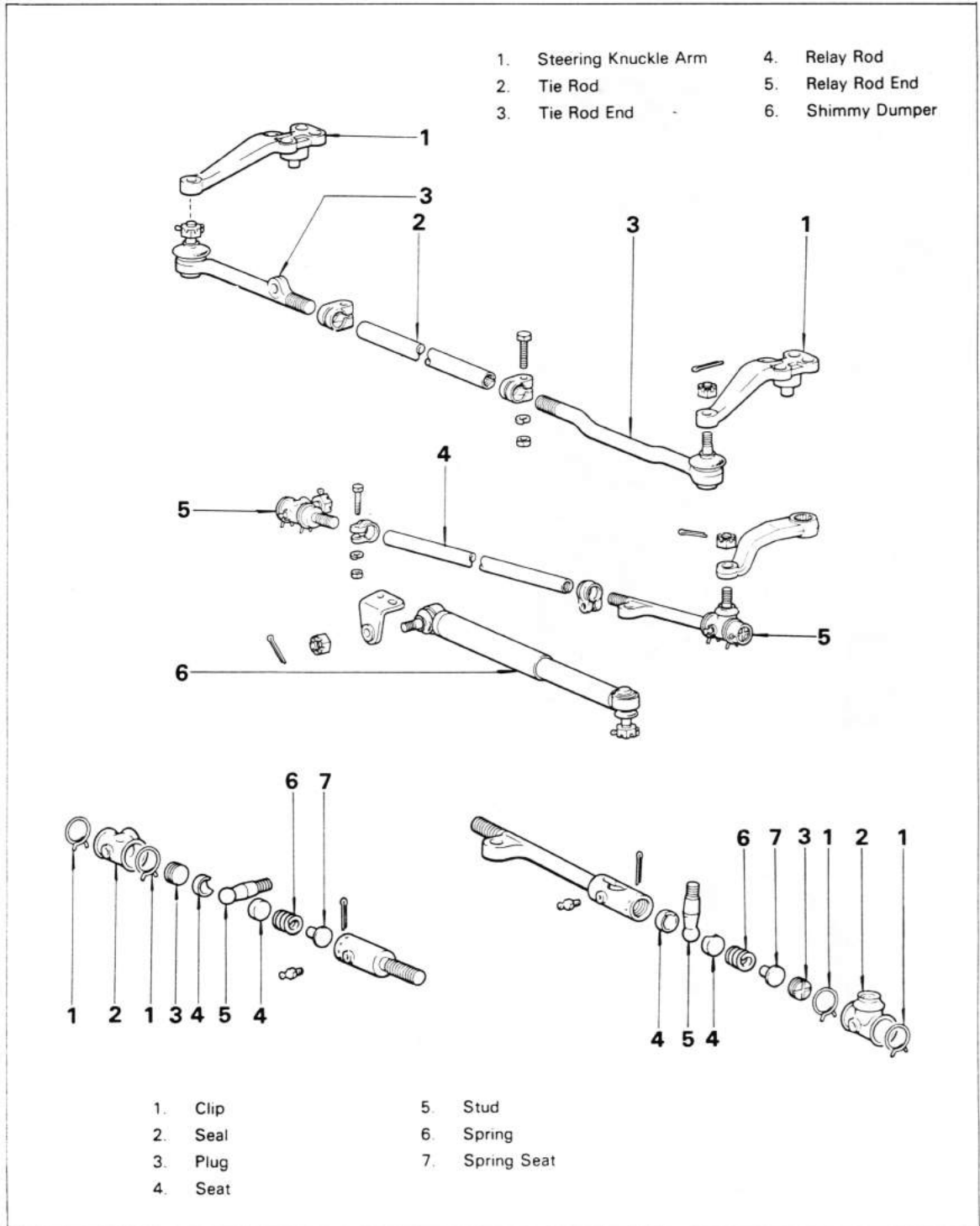

cardiagn.com

Fig. 8-246

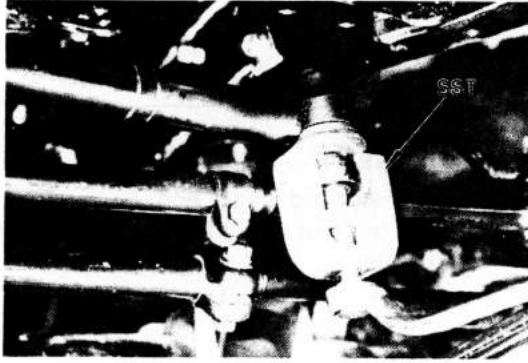

RELAY ROD

REMOVAL

Disconnect the dumper from the relay rod with SST.

SST [09611-22011]

Fig. 8-247

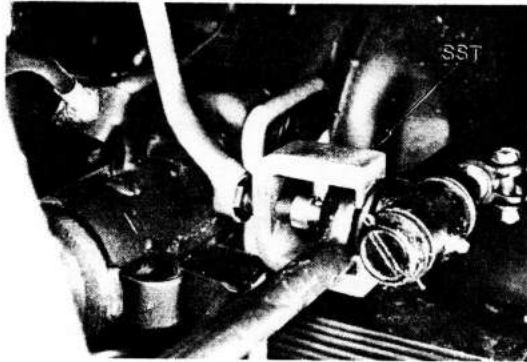

Disconnect the pitman side stud with SST.

SST [09611-20014]

Fig. 8-248

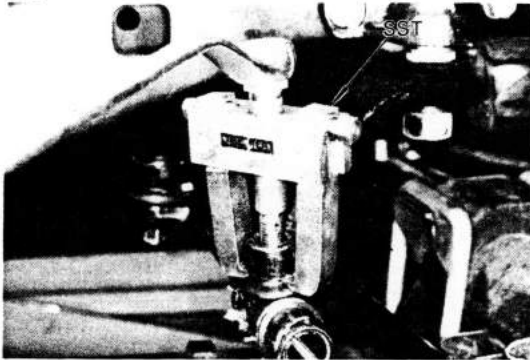

Disconnect the tie rod side stud with SST.

SST [09628-62010]

Fig. 8-249

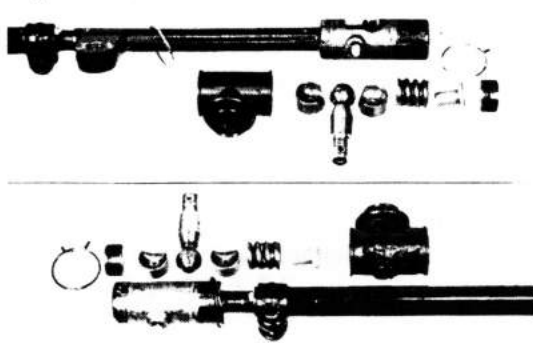

INSPECTION

Relay Rod

1. Check the stud, seat, spring and boot for wear or damage.
2. Check the tube for damage or bending.

Fig. 8-250

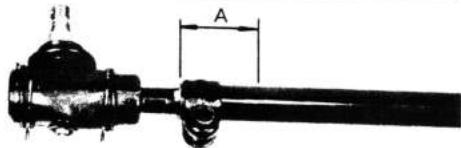
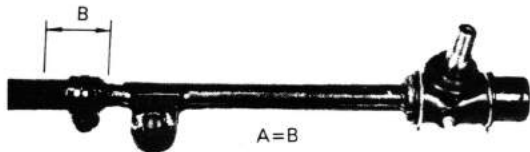

Fig. 8-251



Fig. 8-252

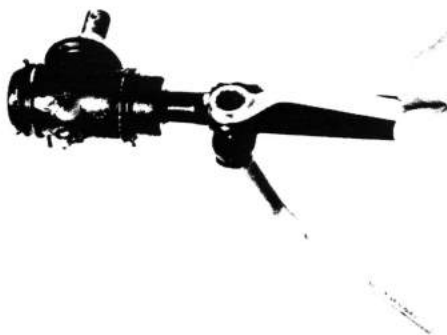

Fig. 8-253

**ADJUSTMENT**

Adjust the relay rod length.

1. Screw the end into the tube equally on both ends.

2. Adjust the rod length.

**Relay rod length: 836 mm
(32.91 in.)**

3. Both side studs are crossed 90 degree.

4. Install the clamp bolt facing opposite for stud.

Tightening torque:

**2.0 — 3.0 kg-m
(15 — 21 ft-lb)**

Fig. 8-254

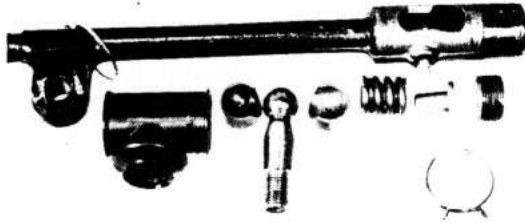

Adjust the plug tightness.

1. Install the damper side as shown in the figure.

Fig. 8-255

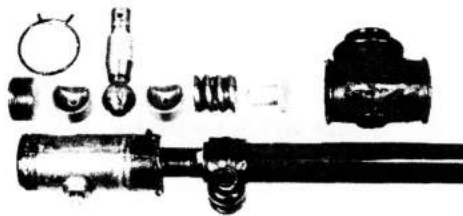

2. Install the tie rod side as shown in the figure.

Fig. 8-256

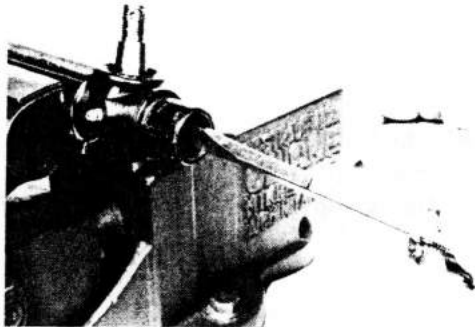

3. Tighten the plug down completely. Be sure that the spring seat and bolt seat come into contact.

Fig. 8-257

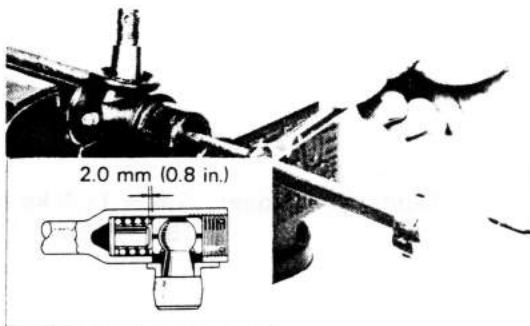

4. Loosen the plug one and one a third turns.

**Spring seat and bolt
seat clearance: 2.0 mm
(0.079 in.)**

Fig. 8-258

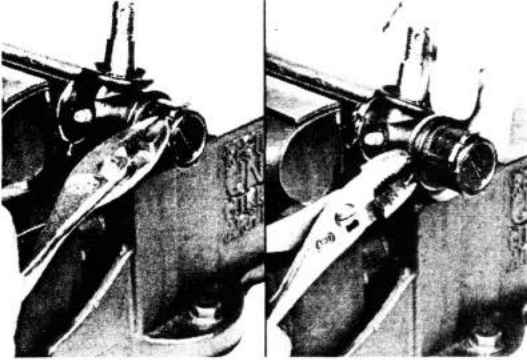

5. Assemble the cotter pin and clip.

Fig. 8-259

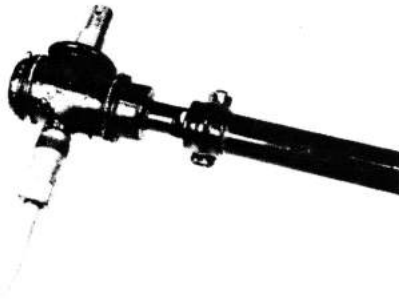

6. Grease where necessary.

Fig. 8-260

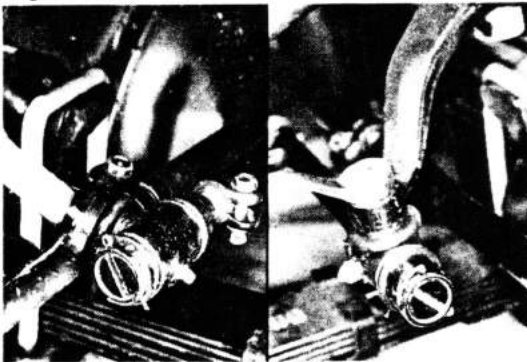

INSTALLATION

Tighten the nut.

Tightening torque: 7.5 – 11.0 kg-m
(55 – 79 ft-lb)

Fig. 8-261

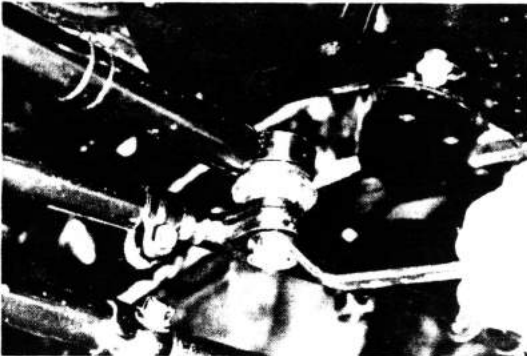

Tighten the nut.

Tightening torque: 7.5 – 11.0 kg-m
(55 – 79 ft-lb)

Fig. 8-262

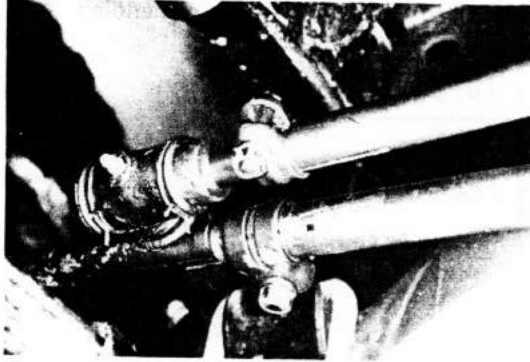

Confirm that there is no interference between the clamp and rod.

Fig. 8-263



**TIE ROD
REMOVAL**

Disconnect both tie rod ends with SST.
SST [09611-22011]

Fig. 8-264

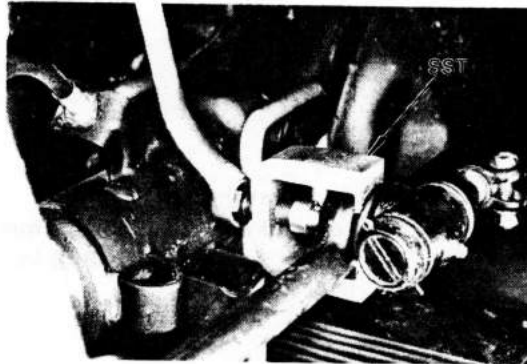

Disconnect the relay rod side with SST.
SST [09611-20014]

Fig. 8-265

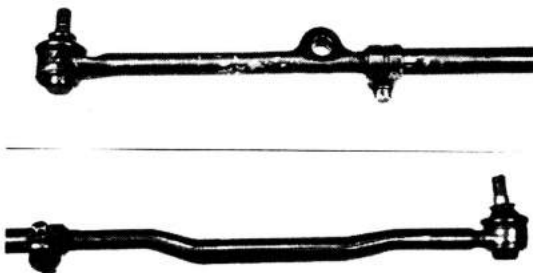

Check the tie rod end for wear or damage.

Fig. 8-266



Check the tube for damage or bending.



Fig. 8-267

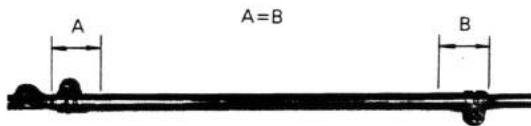

ADJUSTMENT

Adjust the tie rod length.

1. Screw the ends into the tube equally.

Fig. 8-268

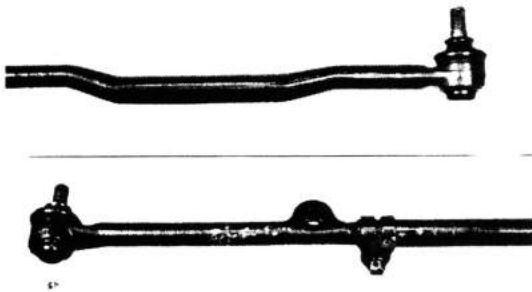

2. Temporarily adjust the tie rod length.

**Tie rod end length: 1,267.4 mm
(49.898 in.)**

Fig. 8-269



3. Temporarily install both side tube clamps.

Fig. 8-270

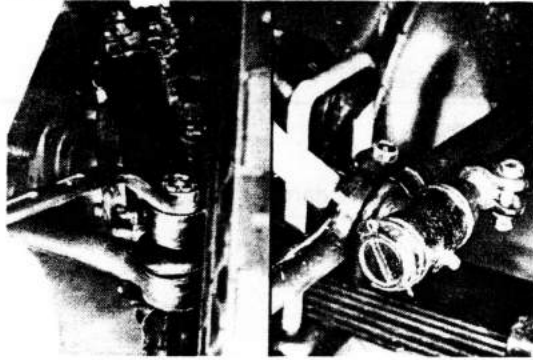

INSTALLATION

Tighten the nut.

Tightening torque: 7.5 — 11.0 kg-m
(55 — 79 ft-lb)

Install the cotter pin.

Fig. 8-271

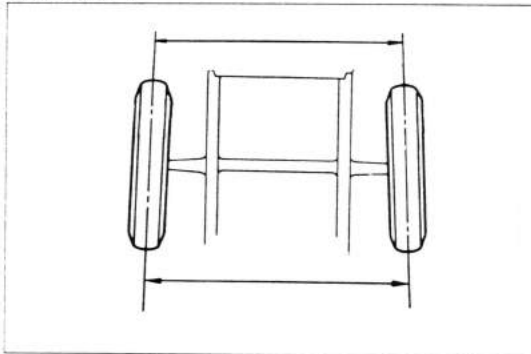

Inspect and adjust the front wheel alignment.

Fig. 8-272

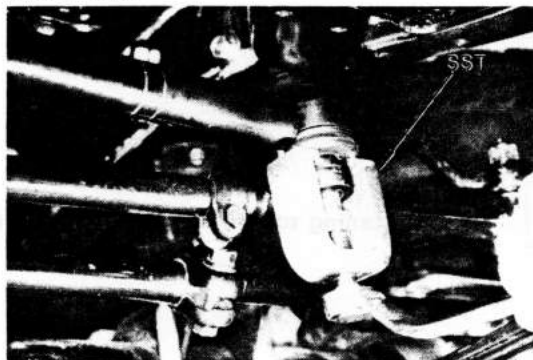

SHIMMY DAMPER

REMOVAL

Disconnect the relay rod side with SST.
SST [09611-22011]

Fig. 8-273



Disconnect the body with SST.
SST [09628-62010]

Fig. 8-274

**INSPECTION**

1. Check for damage or oil leakage.

Fig. 8-275



Check the operation.

Apply an even pressure and insure that the tension is equal throughout the stroke.

Fig. 8-276

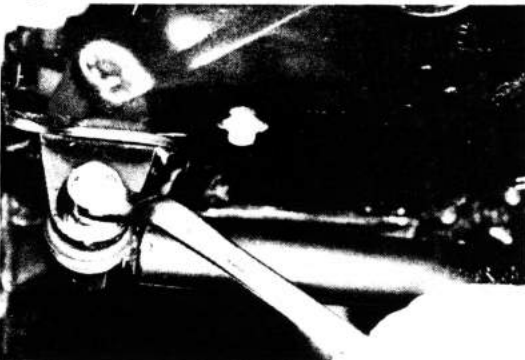

Tighten the nut.

Tightening torque: 7.5 – 11.0 kg-m
(55 – 79 ft-lb)

Fig. 8-277

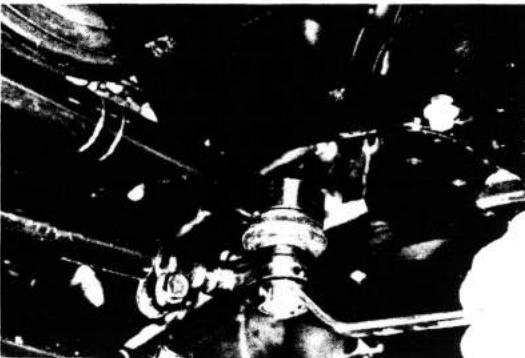

Tighten the nut.

Tightening torque: 7.5 – 11.0 kg-m
(55 – 79 ft-lb)

STEERING LINKAGE (FJ, BJ, HJ4 — SERIES)

REMOVAL & DISASSEMBLY

Remove and disassemble the parts in the numerical order shown in the figure.

Fig. 8-278

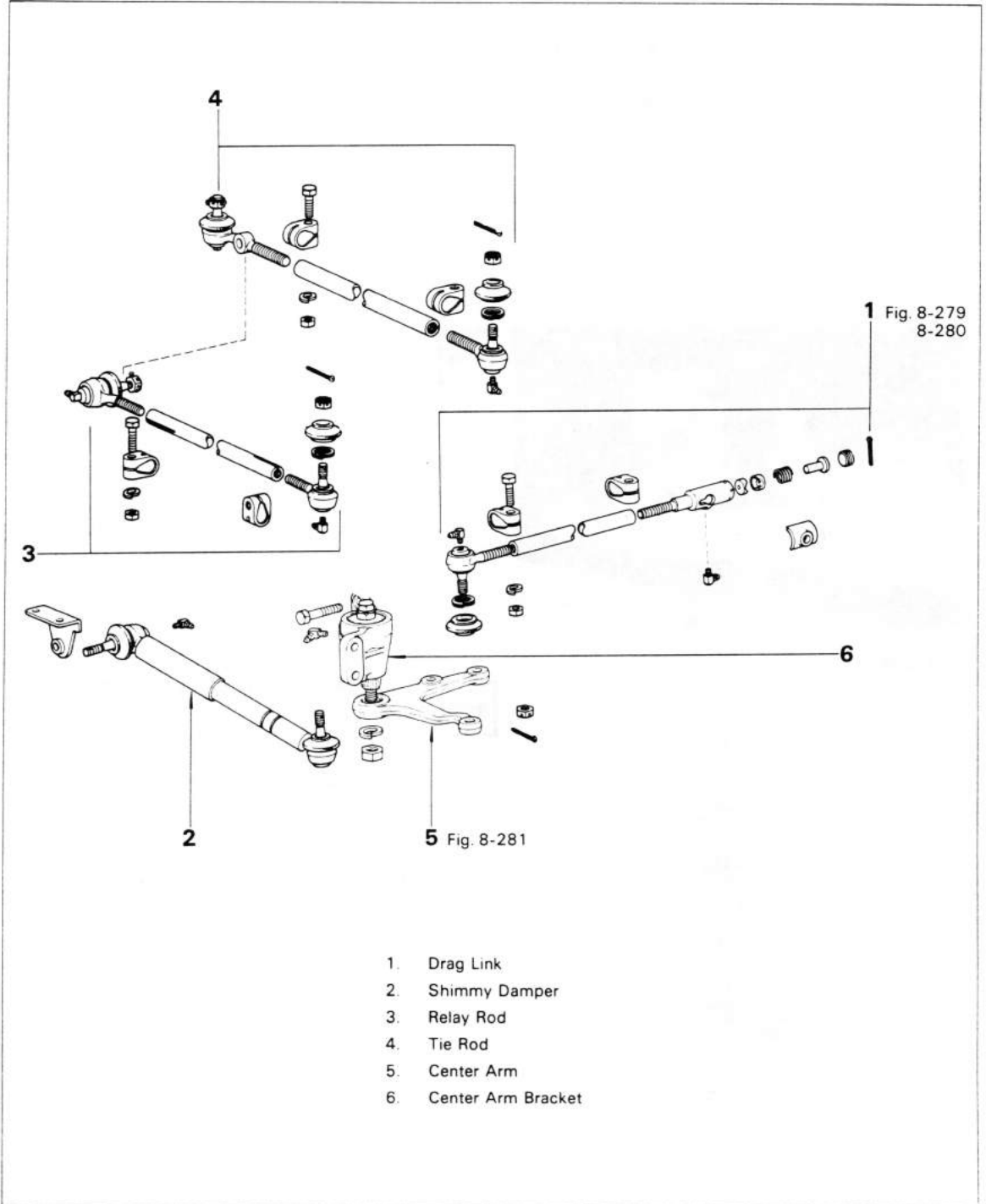
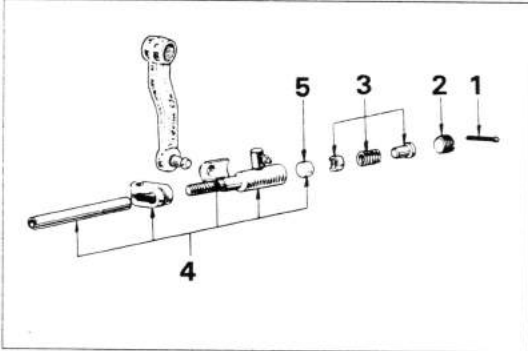
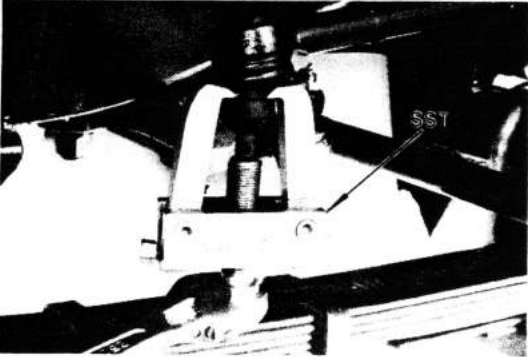

Fig. 8-279



Disassemble the parts in the order shown by numbers.

Fig. 8-280



Disconnect the drag link with SST. SST [09628-62010]

Fig. 8-281

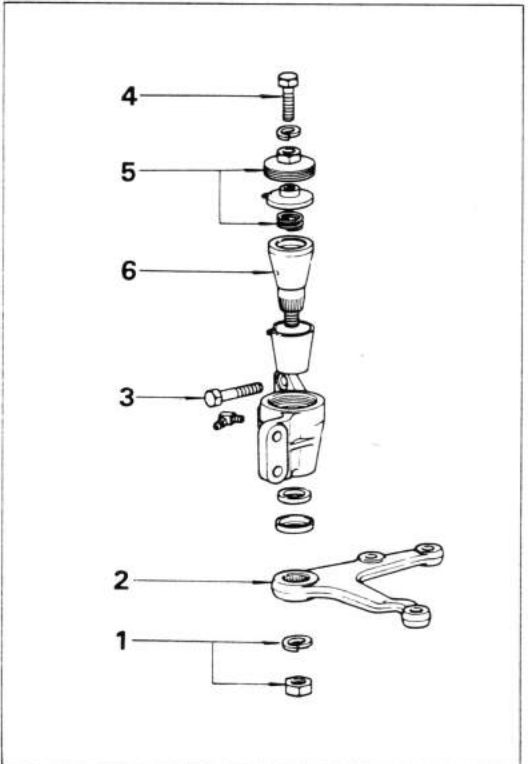

Disassemble the parts in the order shown by numbers.

To remove the arm 2, use SST. SST [09628-62010]

Fig. 8-282

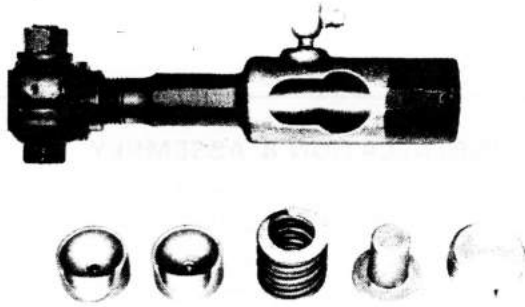

INSPECTION

Seat & Spring

Inspect for wear or damage.

Fig. 8-283



Shaft & Bushing

Inspect for wear or damage.

Fig. 8-284

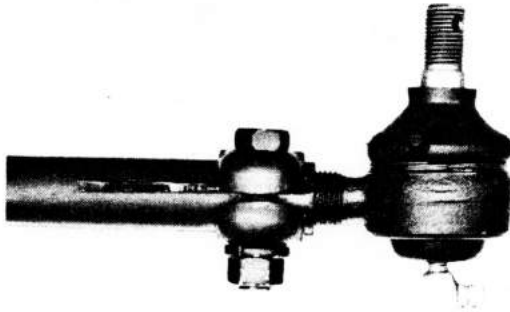

Drag Link, Tie Rod & Relay Rod

1. Inspect the link and rod for bending or cracks.
2. Inspect the ball joint for wear.

INSTALLATION & ASSEMBLY

Install and assemble the parts in the numerical order shown in the figure.

Fig. 8-285

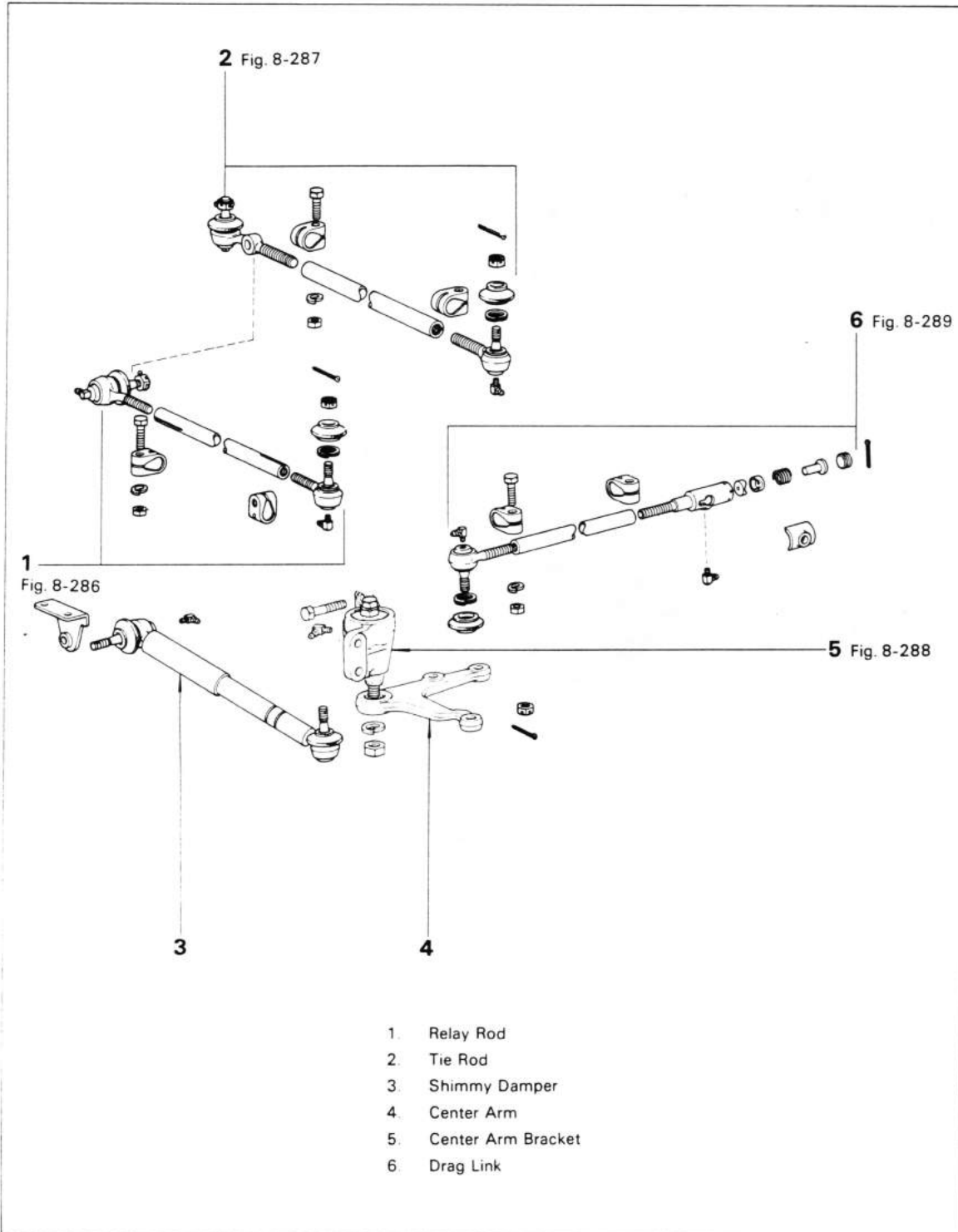
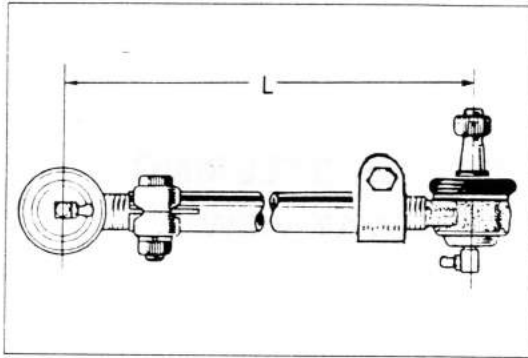

Fig. 8-286



Adjust the length L of relay rod to the standard value.

Relay rod length:
STD 842 mm
(33.15 in.)

Fig. 8-287

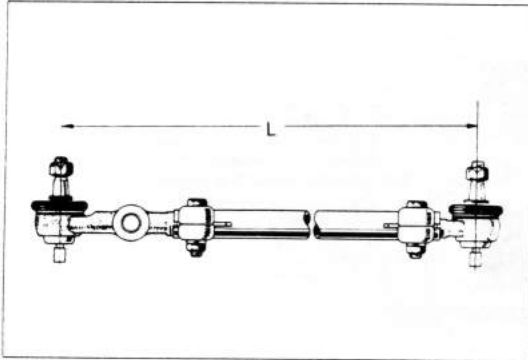

Adjust the length L of tie rod to the standard value.

Tie rod length:
STD 1,205 mm
(47.44 in.)

Fig. 8-288

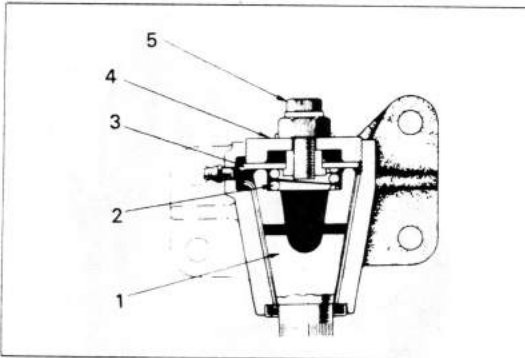

Grease the parts and assemble them in the order shown by numbers.

Tighten the nut 4 fully and then unscrew it 1/4 turn.

Tighten the bolt 5 fully.

Fig. 8-289

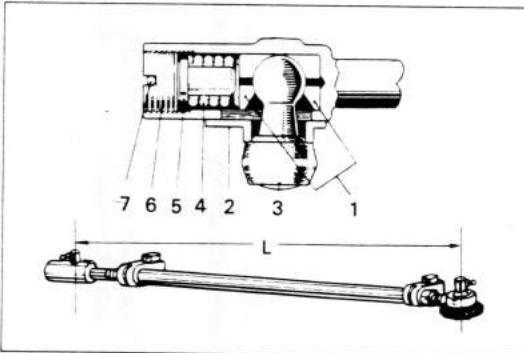

Grease the parts and assemble them in the order shown by numbers.

Tighten the end plug 6 fully and then unscrew it 1/2 turn.

Adjust the length L of drag link to the standard value.

Drag link length:
STD 855 mm
(33.66 in.)

POWER STEERING CUTAWAY VIEW

Fig. 8-290

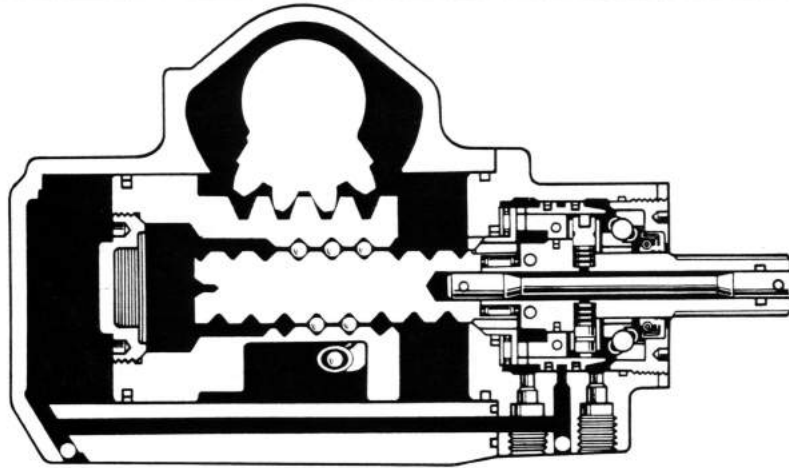

FJ, BJ, HJ4 — Series

FJ, HJ6 — Series

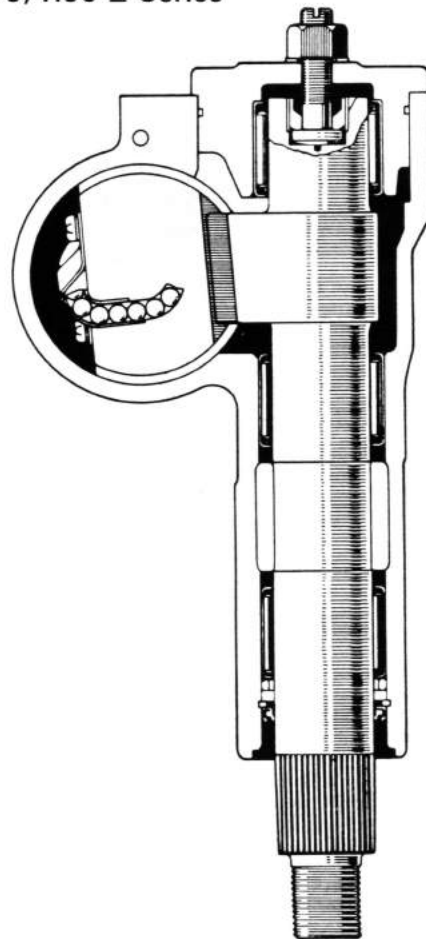
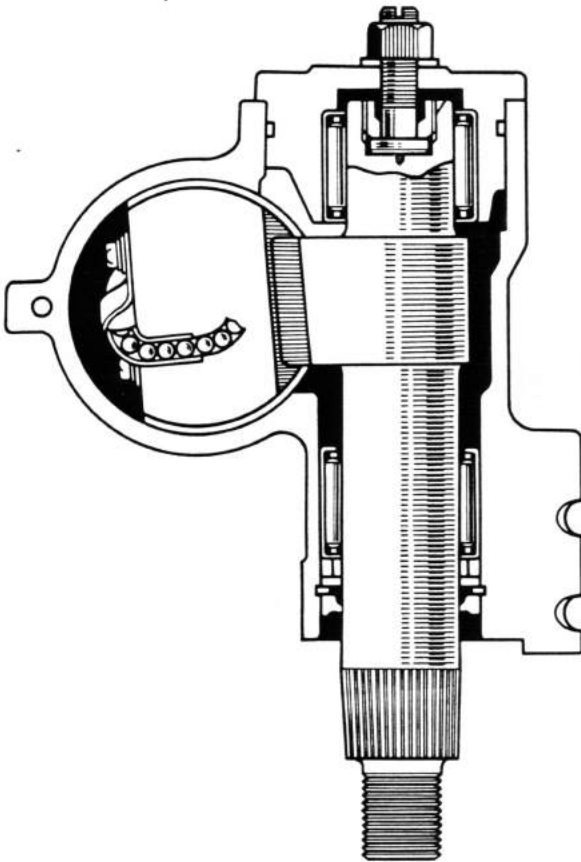

Fig. 8-291

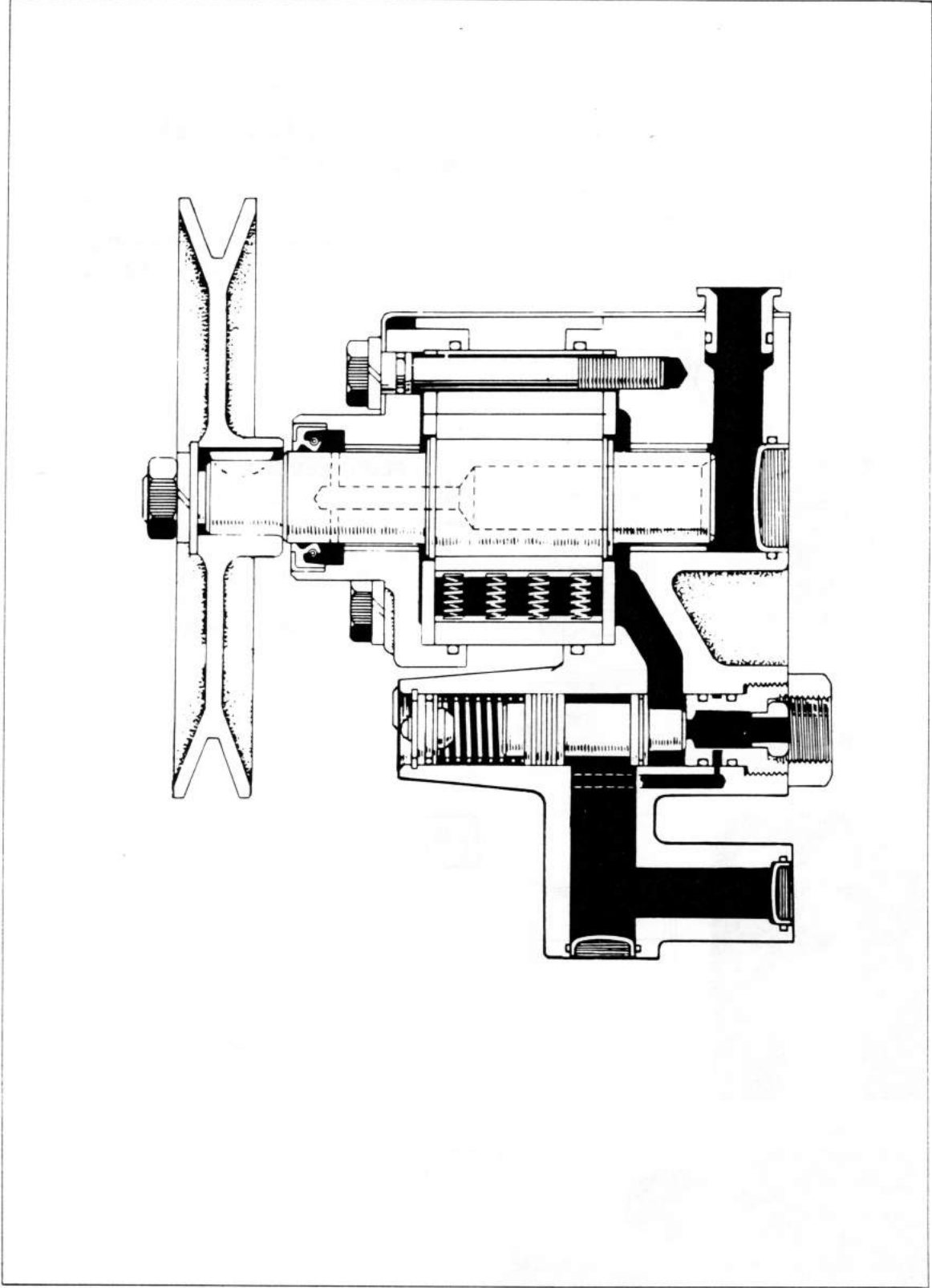
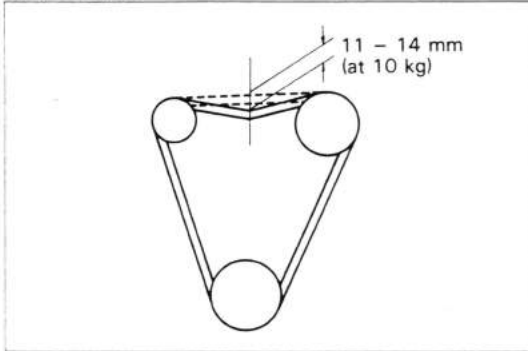

Fig. 8-292

**ON-VEHICLE INSPECTION****DRIVE BELT**

Measure the belt tension between alternator pulley and vane pump pulley.

**Tension: 11 – 15 mm/10 kg
(0.43 – 0.59in./22 lb)**

Fig. 8-293

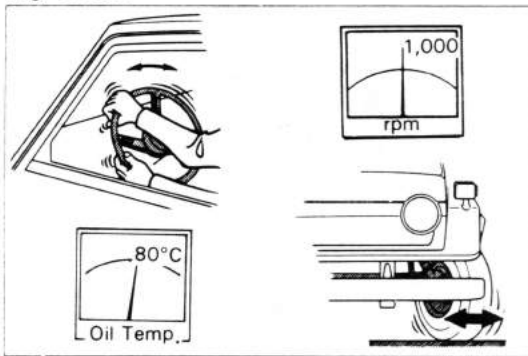
**FLUID LEVEL**

1. Keep the vehicle level.
2. Warm up the engine.
3. With engine running at 1,000 rpm, turn the steering wheel from lock to lock several times to boost fluid temperature.

Fluid temperature:

**40 – 80°C
(104 – 176°F)**

Fig. 8-294

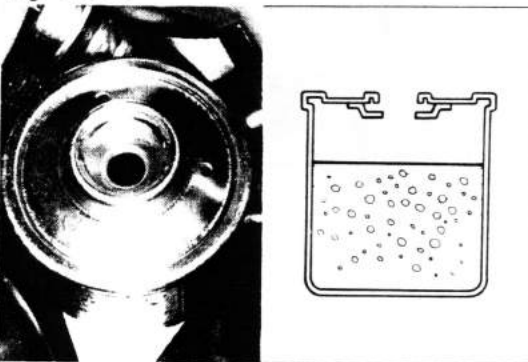

4. Inspect for foaming or emulsification. Note that foaming and emulsification indicate the existence of air in the system or that the fluid level is too low.

Fig. 8-295



5. Inspect the fluid level with a dip stick.
6. Inspect the complete system for fluid leakage.

Fig. 8-296

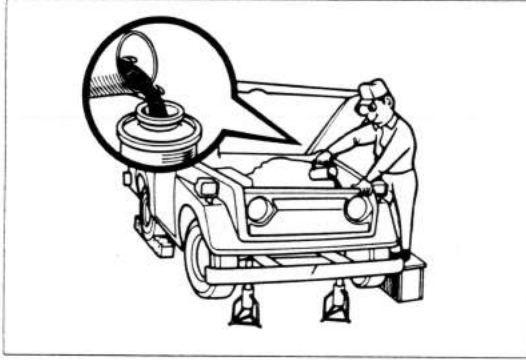

BLEEDING



1. Inspect the fluid level and add fluid if necessary.
Fluid: ATF type Dexron
2. Jack up the front of the vehicle and support it on stands.

Fig. 8-297

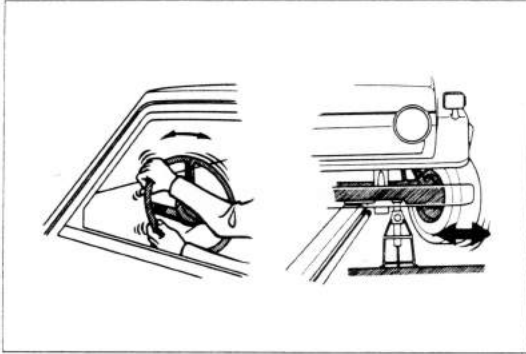

3. Turn the steering wheel from lock to lock two or three times.

Fig. 8-298



4. Recheck the fluid level.

Fig. 8-299

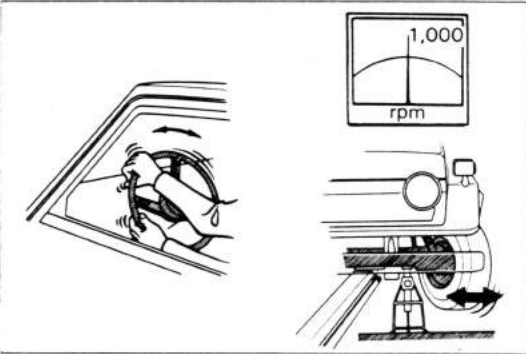

5. Start the engine and run it at 1,000 rpm.
6. Turn the steering wheel from lock to lock two or three times.

Fig. 8-300

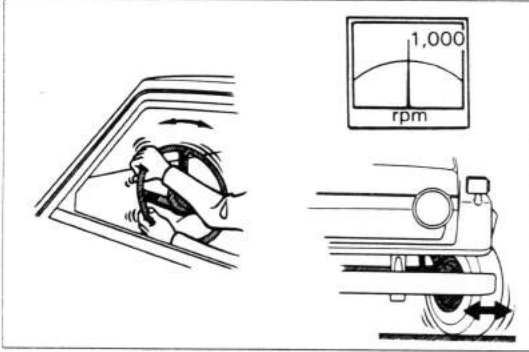

7. Lower the front of vehicle.
8. Run the engine at 1,000 rpm.
9. Turn the steering wheel from lock to lock several times.

Fig. 8-301

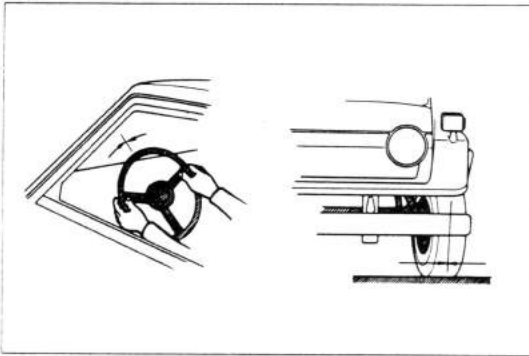

10. Center the steering wheel.

Fig. 8-302

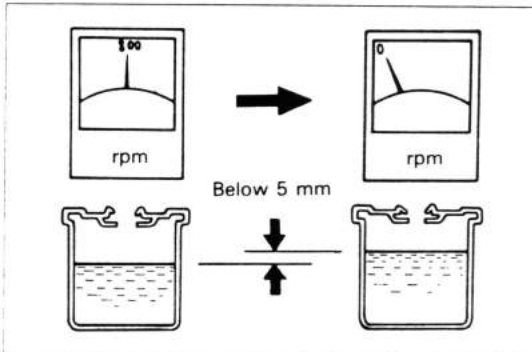

11. Bleeding is complete if the fluid level in the reservoir has not risen excessively and no foaming or emulsification is observed when the engine is stopped.

Maximum rise of fluid level:

Below 5mm

(0.20 in.)

12. If foaming or excessive rise of fluid is noticed, repeat step 8 – 11 until the level is correct.

Fig. 8-303

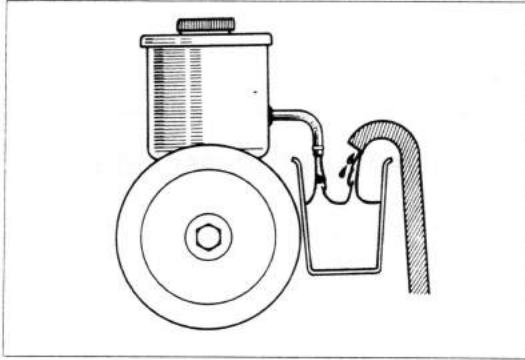

FLUID REPLACEMENT

1. Jack up the front of the vehicle.
2. Remove the return hose from the fluid reservoir and drain the fluid into a vessel.

Fig. 8-304

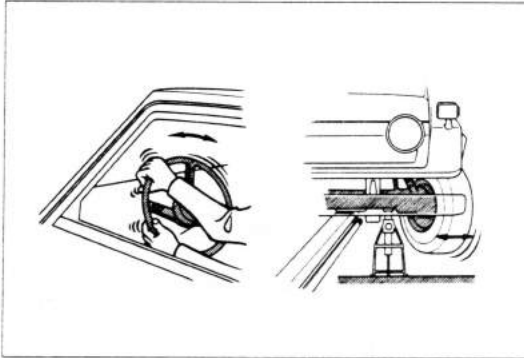

3. Turn the steering wheel from lock to lock, while draining the fluid.

Fig. 8-305

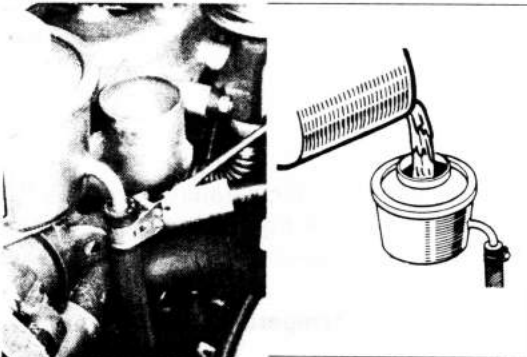

4. Connect the return hose to the fluid reservoir.
5. Add fresh fluid.

Fluid: ATF type Dexron

Capacity:

Vane pump 300 cc (18.3 cu in.)

Gear housing 330 cc (20.1 cu in.)

Fig. 8-306

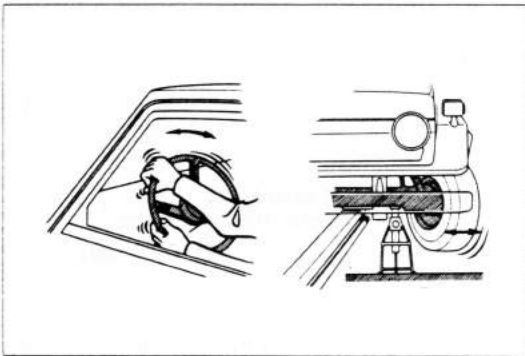

6. Bleed the system.

Fig. 8-307

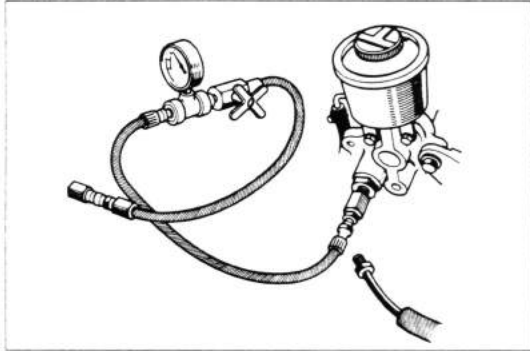
**FLUID PRESSURE INSPECTION**

1. Attach a pressure gauge.
 - (1) Disconnect the pressure hose from the vane pump with SST.
 - SST [09631-22020]
 - (2) Connect the gauge side of the pressure gauge to the vane pump.

Fig. 8-308

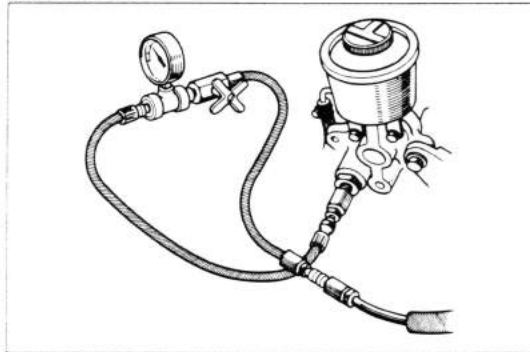

- (3) Connect the valve side of the pressure gauge to the pressure hose with SST.
- SST [09631-22020]
- (4) Bleed the air.
- (5) Inspect the fluid level.

Fig. 8-309

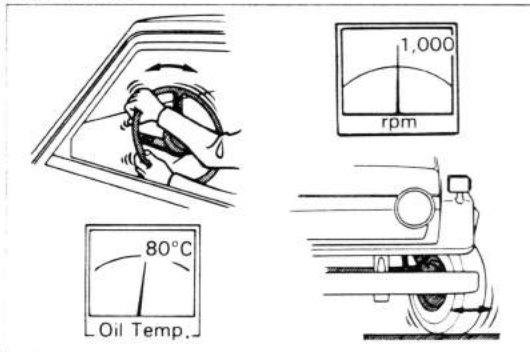

2. Boost the fluid temperature by turning the steering wheel from lock to lock several times with the engine running at 1,000 rpm.

**Fluid temperature: 80°C
(176°F)**

3. Measure the fluid pressure generated by the vane pump.
 - (1) Idle the engine.
 - (2) Measure the fluid pressure reading with the pressure gauge valve fully closed.

**Fluid pressure:
More than 72 kg/cm²
(1,022 psi)**

Fig. 8-310

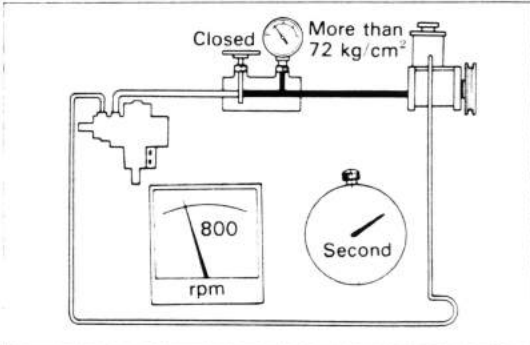

— Note —
Do not keep the valve closed for more than 10 seconds.

- (3) If the pressure does not reach 72 kg/cm² (1,022 psi) within 10 seconds, there is a problem with the vane pump.

Fig. 8-311

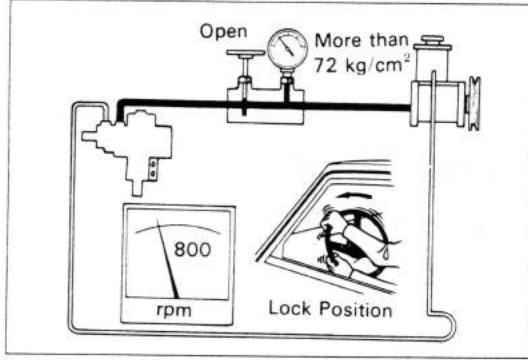

4. Measure the fluid pressure utilized in the gear housing.
 - (1) Fully open the pressure valve.
 - (2) With the steering wheel at full lock, measure the fluid pressure reading.

Fluid pressure:

**More than 72 kg/cm²
(1,022 psi)**

Fig. 8-312

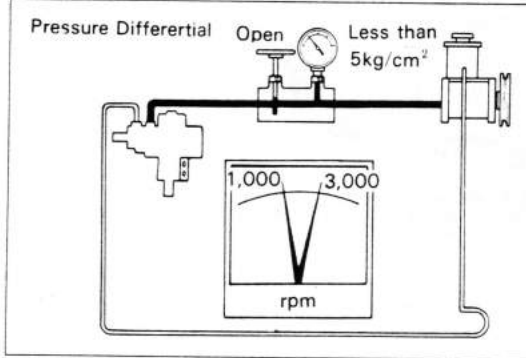

5. Measure the pressure differential under no-load running condition (flow control valve operation check).

- (1) Fully open the pressure gauge valve.
- (2) Measure the fluid pressure with the engine running at 1,000 rpm.
- (3) Measure the fluid pressure with the engine running at 3,000 rpm.

Pressure differential:

**Less than 5 kg/cm²
(71 psi)**

- (4) If not within limit, check the flow control valve.

Fig. 8-313

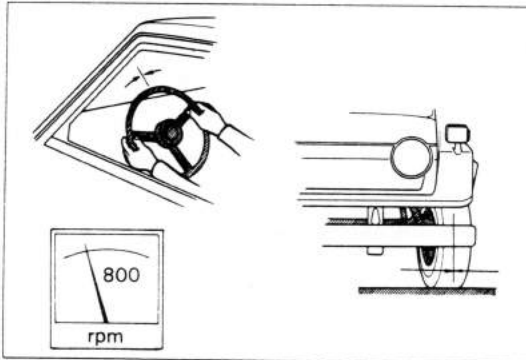

STEERING POWER INSPECTION

1. Place the vehicle on flat surface.
2. Turn the steering wheel to the straight ahead position (midpoint).
3. Idle the engine.

Fig. 8-314

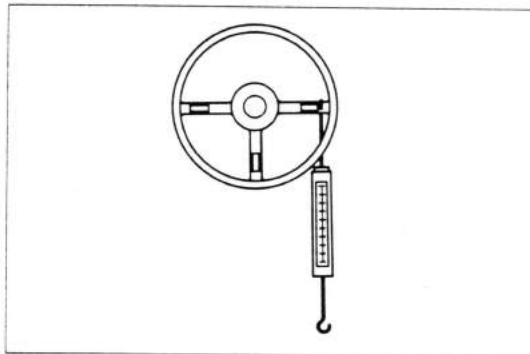

4. Measure the steering power at the steering wheel within one turn on both side of midpoint.

Steering effort:

**Less than 6.0 kg
(13.2 lb)**

VANE PUMP

REMOVAL

Remove the parts in the numerical order shown in the figure.

Fig. 8-315

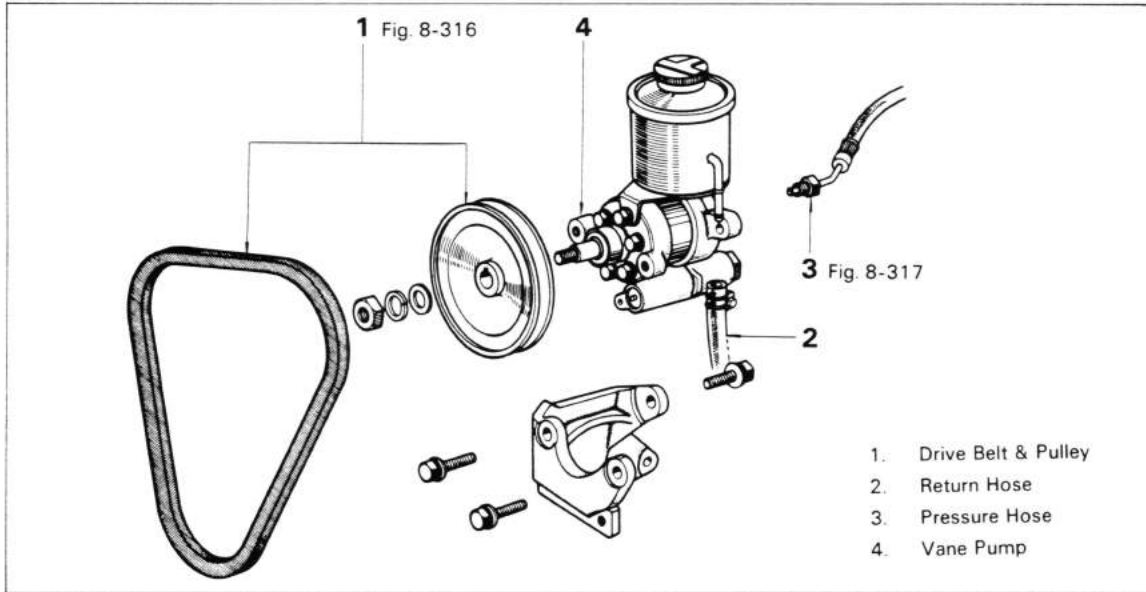
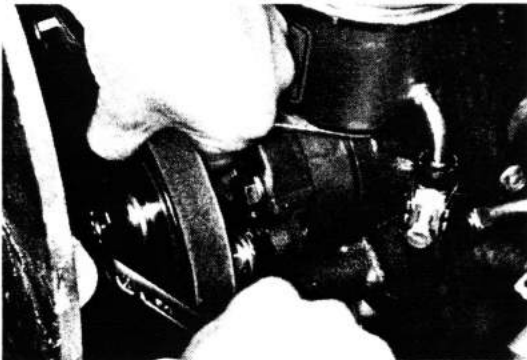

Fig. 8-316



Before releasing tension of the drive belt, loosen the pulley nut.

Fig. 8-317



Disconnect the pressure hose with SST, SST [09631-22020]

DISASSEMBLY

Disassemble the parts in the numerical order shown in the figure.

Fig. 8-318

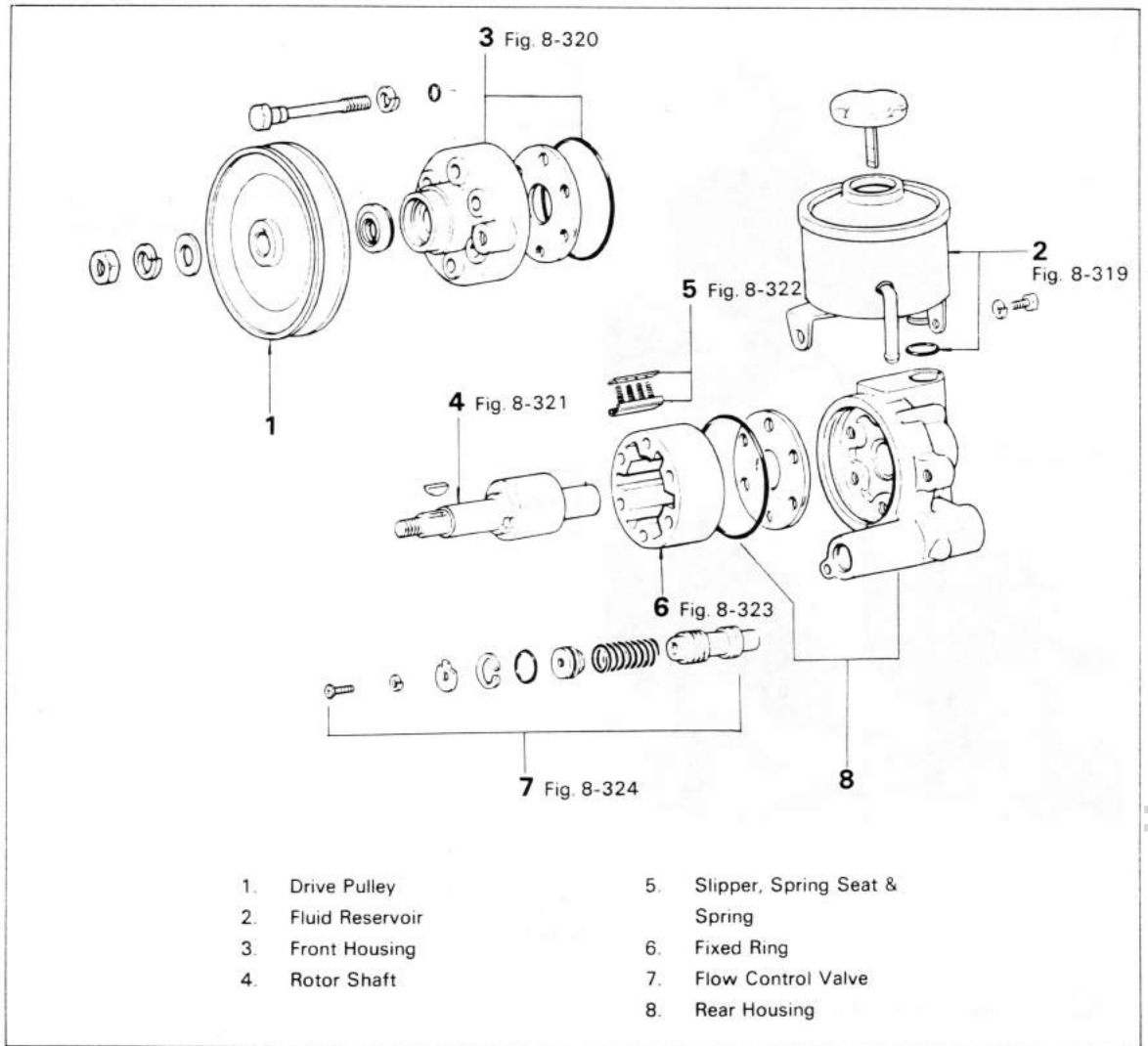
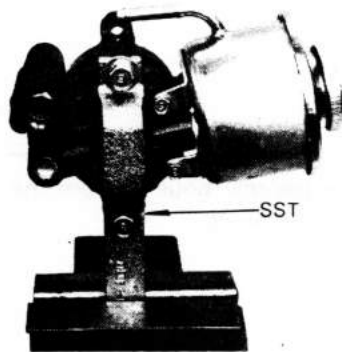

Fig. 8-319



Attach SST to the vane pump and hold it in a vice.

SST (09631-00030) of set [09630-00010]

cardiagn.com

Fig. 8-320



After affixing matchmarks, remove only the front housing with a soft hammer.

— Caution —

Do not pull out the rotor and fixed ring.
Do not allow the slippers and springs to fly out.

Fig. 8-321

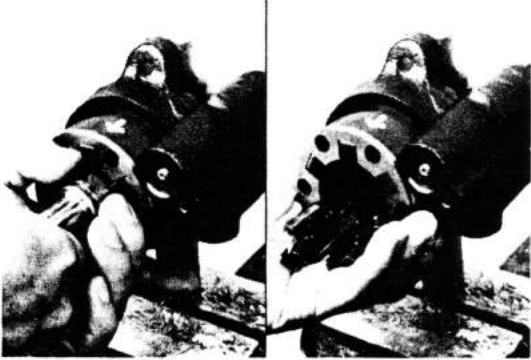

Remove the rotor shaft.

Fig. 8-322

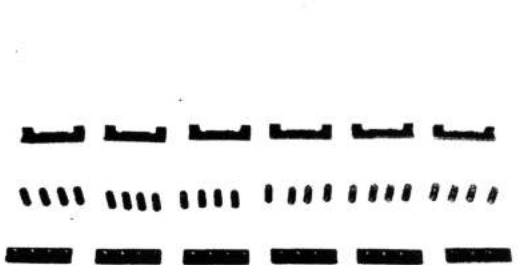

Confirm the numbers of each part.

- | | |
|----------------|----|
| 1. Slipper | 6 |
| 2. Spring | 24 |
| 3. Spring seat | 6 |

Fig. 8-323



Remove the rear housing from the fixed ring with soft hammer.



Remove the flow control valve plug in numerical order as shown in the figure below.

Fig. 8-324

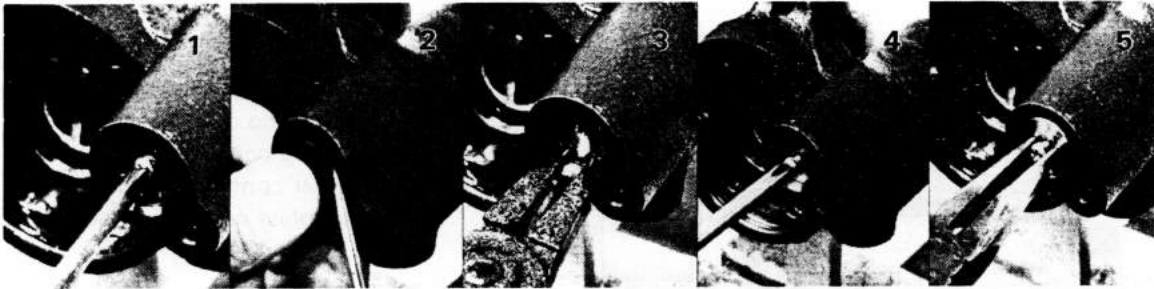
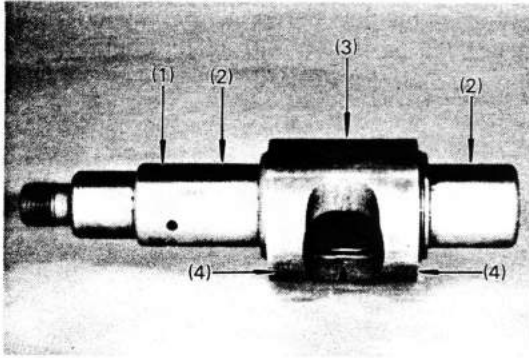
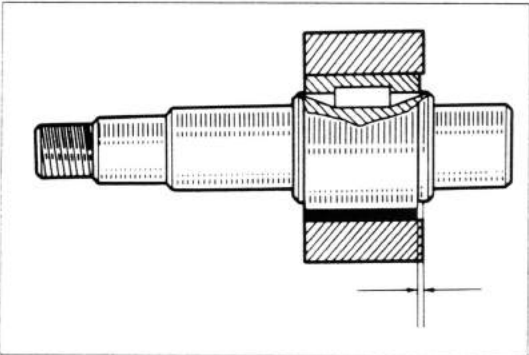

Fig. 8-325

**INSPECTION & REPAIR****Rotor Shaft**

1. Inspect the following for wear or damage.
 - (1) Oil seal tip contact surface
 - (2) Bushing contact surface
 - (3) Slipper contact surface
 - (4) Side plate contact surface

Fig. 8-326



2. Measure overall length of the rotor and fixed ring.

Fixed ring length — Rotor length:

STD	0.03 mm
	(0.0012 in.)
Limit	0.06 mm
	(0.0024 in.)

Fig. 8-327

**Slipper & Spring**

1. Inspect the surface of the slipper for wear or damage.

Thickness:

STD	1.55 mm
	(0.0610 in.)
Limit	1.40 mm
	(0.0551 in.)

Length:

STD	w/mark 39.940 mm
	(1.5724 in.)
	w/o mark 39.945 mm
	(1.5726 in.)

Limit	39.920 mm
	(1.5717 in.)

2. Measure the free height of the spring.

Free height:

STD	14 mm
	(0.55 in.)
Limit	13 mm
	(0.51 in.)

Fig. 8-328

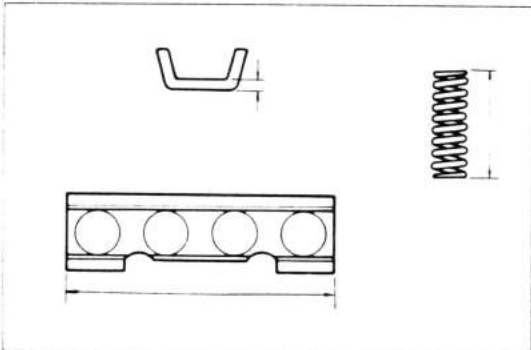
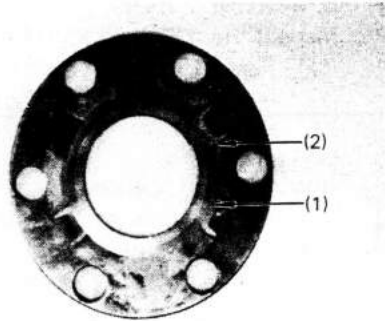

Fig. 8-329



Side Plate

Inspect the following for wear or damage.

1. Rotor contact surface
2. Slippers contact surface

Fig. 8-330

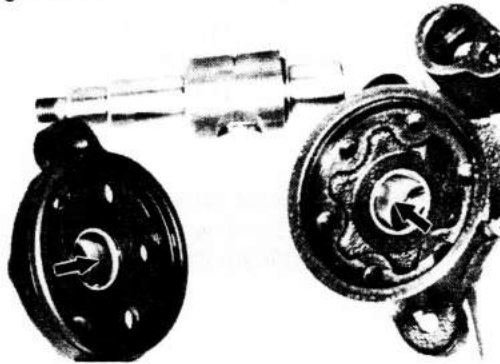

Housing

1. Inspect the bushings for wear or damage.

Fig. 8-331

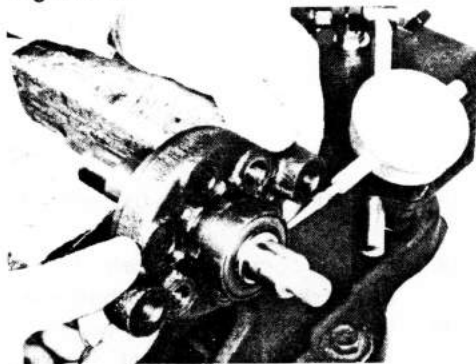

2. Measure the clearance between the rotor shaft and the front housing.

Clearance:

STD 0.010–0.015 mm
(0.0004–0.0006 in.)

Limit 0.03 mm
(0.0012 in.)

Fig. 8-332



3. Measure the clearance between the rotor shaft and the rear housing.

Clearance:

STD 0.010–0.015 mm
(0.0004–0.0006 in.)

Limit 0.03 mm
(0.0012 in.)

Fig. 8-333

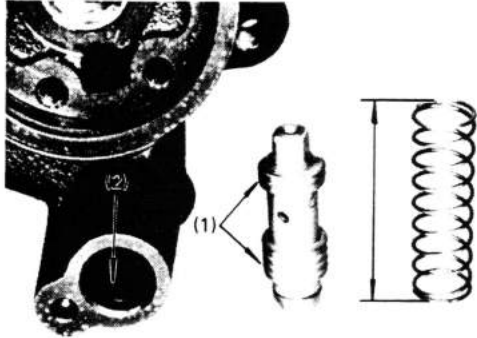
**Flow Control Valve**

1. Inspect the following for wear or damage.
 - (1) Flow control valve
 - (2) Inner surface of the control valve housing
2. Measure free height of the spring.

Free height:

STD	50mm (1.97 in.)
Limit	47 mm (1.85 in.)

Fig. 8-334

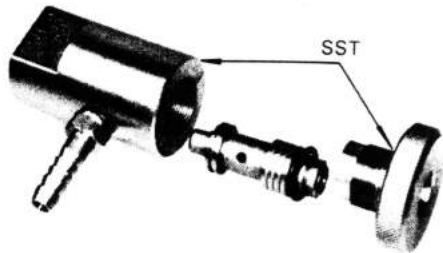

3. Pressure leakage test
 - (1) Install the flow control valve to SST. SST [09630-30030]

Fig. 8-335

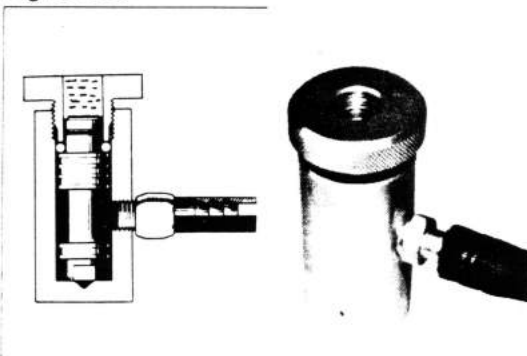

- (2) Pour cleaning oil into the center hole of the locking nut.
- (3) Apply compressed air (4 – 5 atmospheres) to the air hole joint.
- (4) If bubbles can be seen coming out through the center of the valve, there is pressure leakage.

Fig. 8-336

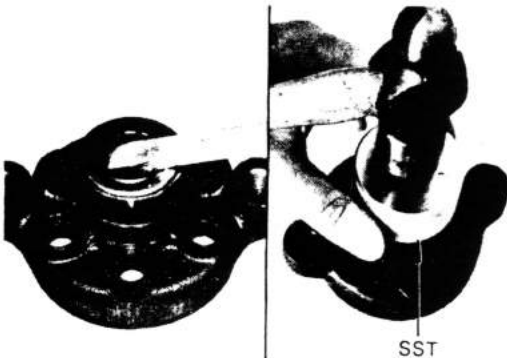
**Replace The Front Housing Oil Seal**

1. Remove the oil seal with a screwdriver.
2. Install a new oil seal with SST. SST (09632-00010) of set [09630-00010]



ASSEMBLY

Assemble the parts in the numerical order shown in the figure.

Fig. 8-337

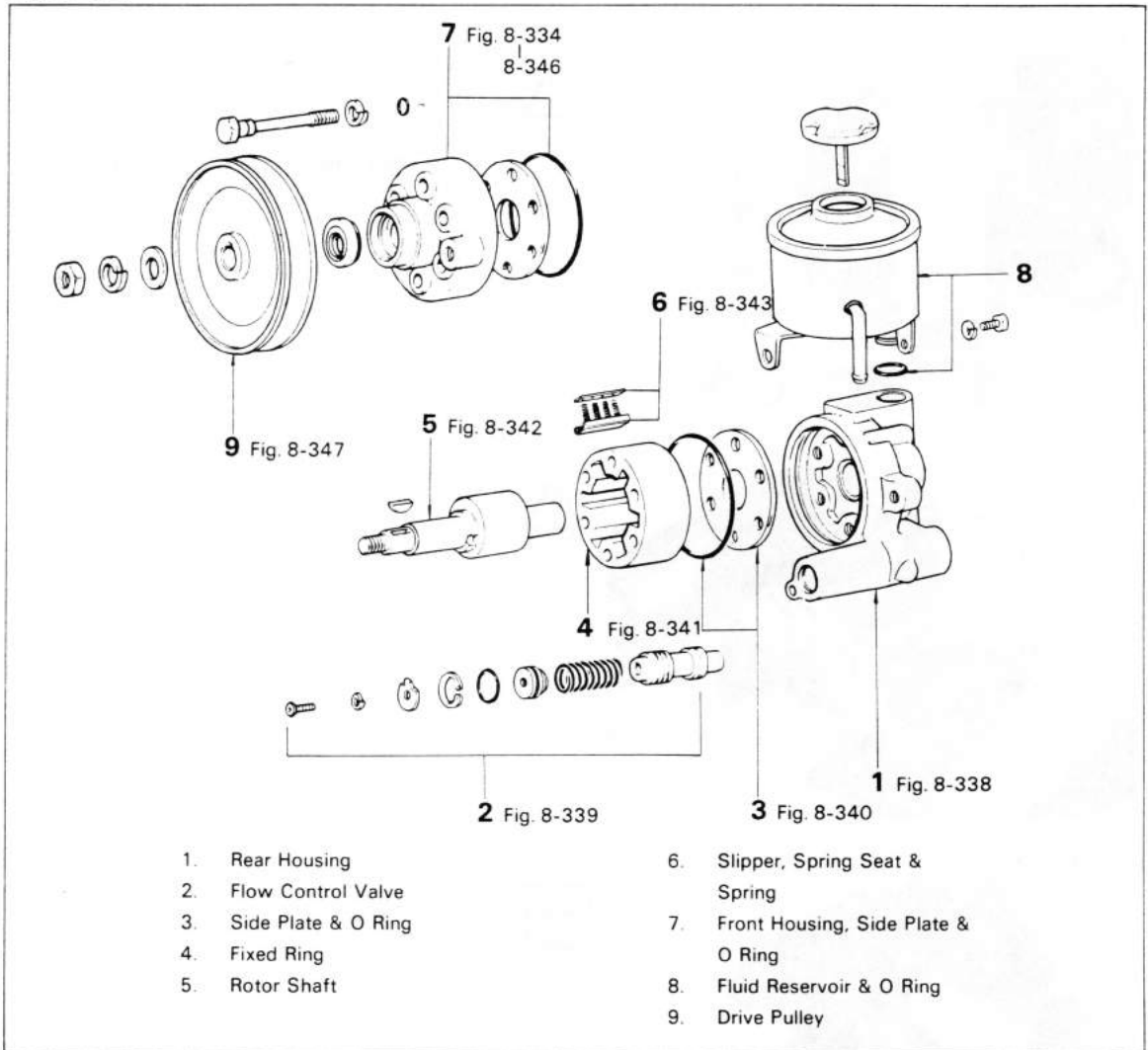
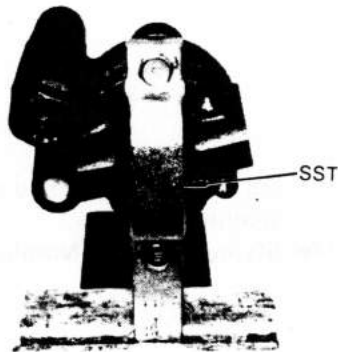

Fig. 8-338



Attach SST to the rear housing and hold it in a vice.

SST (09631-00030) of set [09630-00010]

Fig. 8-339

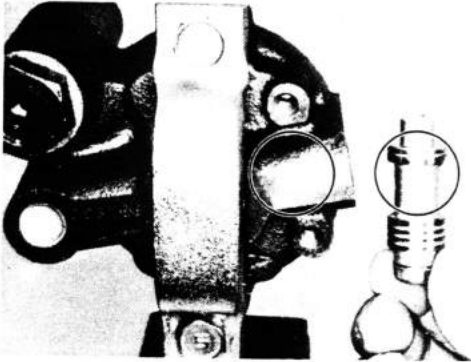

Be sure the identifying mark on the valve matches the identifying mark scribed on the rear of the pump body.

Identifying marks: A ~ F

Fig. 8-340

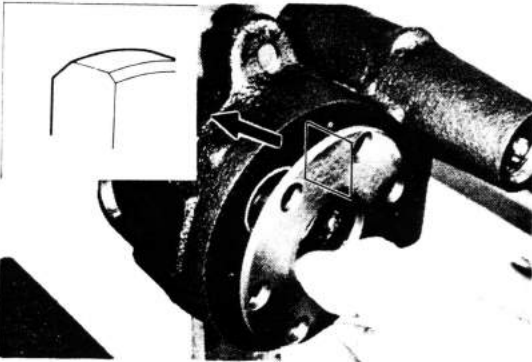

To assemble, place the side plate with the larger bevelled width facing towards the housing side.

Fig. 8-341



Using the two bolts as a guide, drive in the fixed ring evenly with a soft hammer.

Fig. 8-342

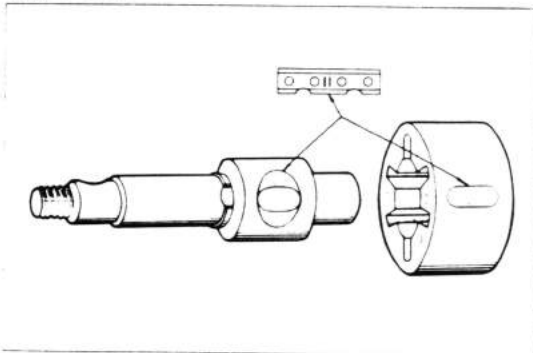

Select a fixed ring, rotor shaft and slipper with matching identifying marks.

Identifying marks: Nothing or 2

Fig. 8-343

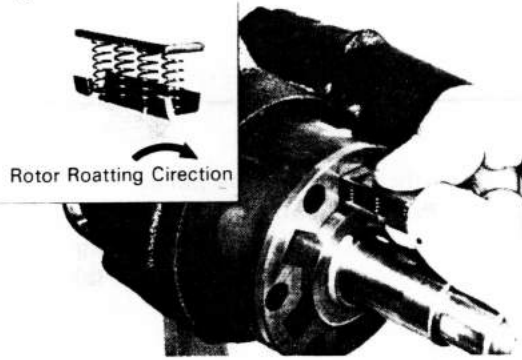

Compress the spring with the slipper and spring seat and install. Position the slipper notch in the direction shown in the figure.

Fig. 8-344



To assemble, place the side plate with the larger bevelled width facing towards the housing side.

Fig. 8-345

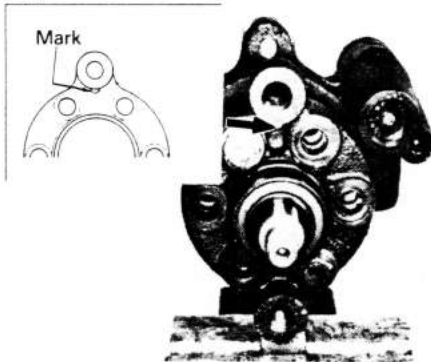

Fit the front housing, and position the mark as is shown in the figure.

Fig. 8-346

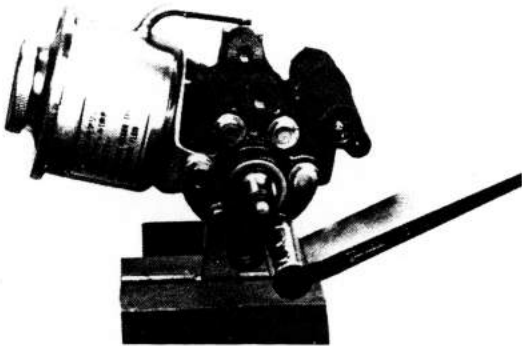

Tighten evenly in three or four rotations.

Tightening torque: 3.3-4.2 kg-m
(24-30 ft-lb)

2 small bolts behind the reservoir:
0.4-0.7 kg-m
(35-60 in.-lb)

Fig. 8-347



Check the preload at the pulley.

Preload (while turning):

**Less than 2.8 kg
(6.2 lb)**

INSTALLATION

Install the parts in the numerical order shown in the figure.

Fig. 8-348

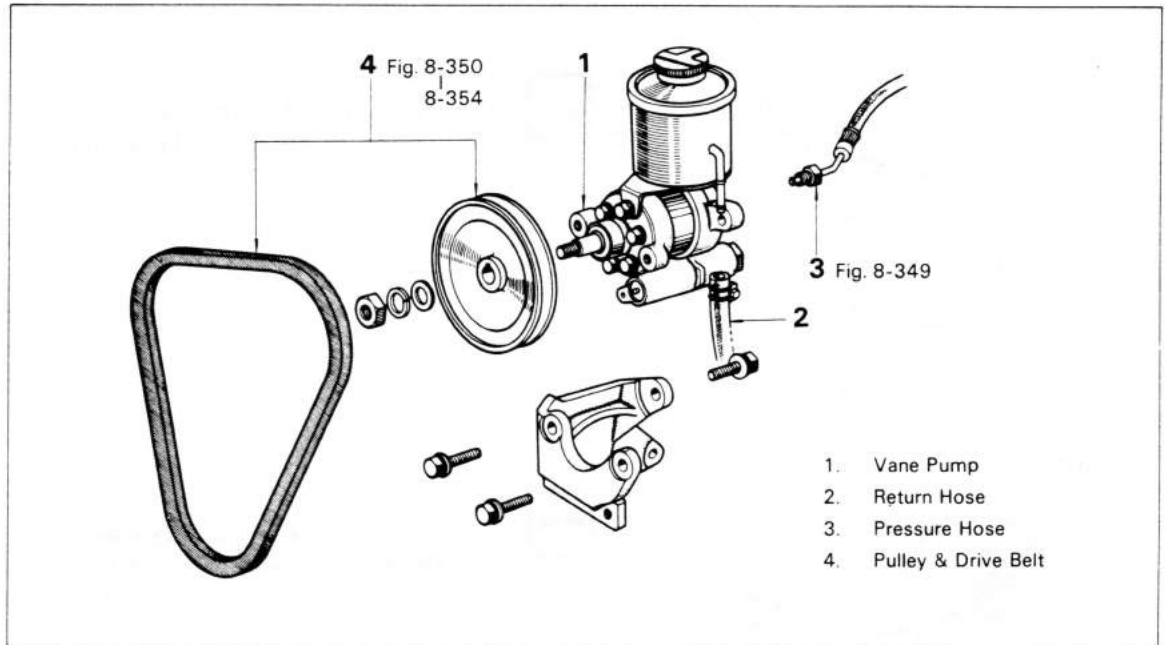
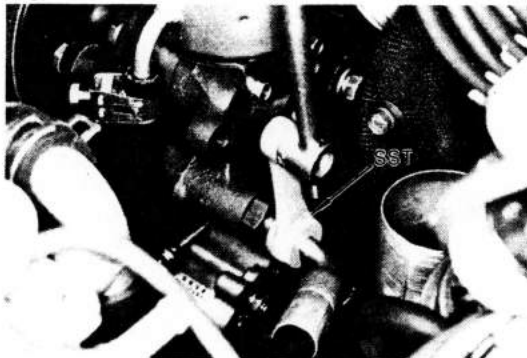

Fig. 8-349



Connect the pressure hose with SST.
SST [09631-22020]

**Tightening torque: 4.0–5.0 kg-m
(29–36 ft-lb)**

Fig. 8-350



Tighten the pulley set nut securely.

**Tightening torque: 3.5–5.4 kg-m
(26–39 ft-lb)**

Fig. 8-351

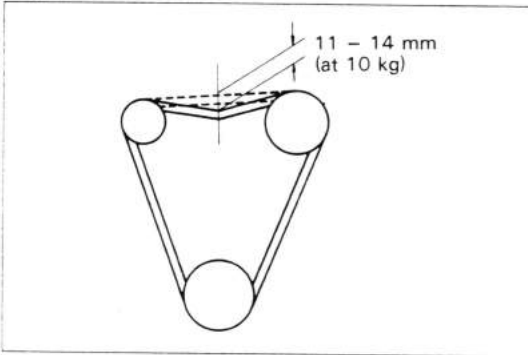

Adjust the drive belt tension.

Tension: 11-14 mm/10 kg
(0.4-0.6 in./22 lb)

Fig. 8-352

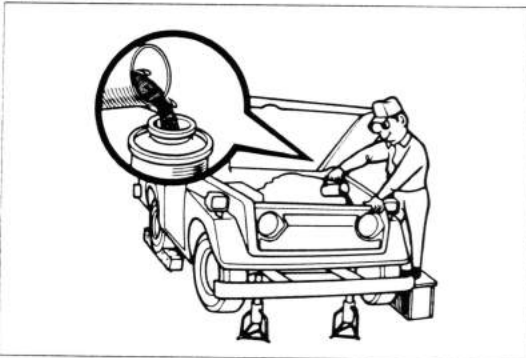

Fill with fluid.

Fluid: ATF type Dexron
Capacity: Vane pump 300cc
(18.3 cu in.)

Fig. 8-353

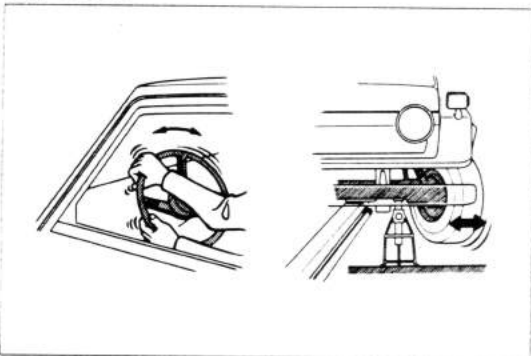

Bleed the system.

Fig. 8-354

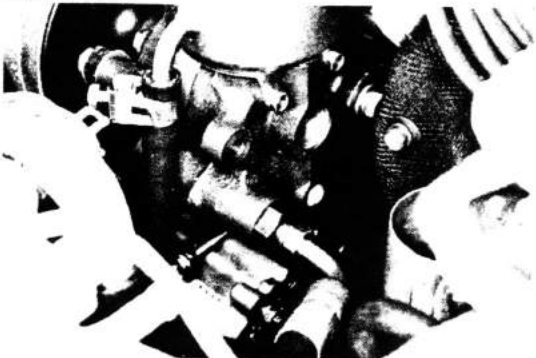

Boost the fluid pressure to check for fluid leakage.

GEAR HOUSING

REMOVAL

Remove the parts in the numerical order shown in the figure.

Fig. 8-355

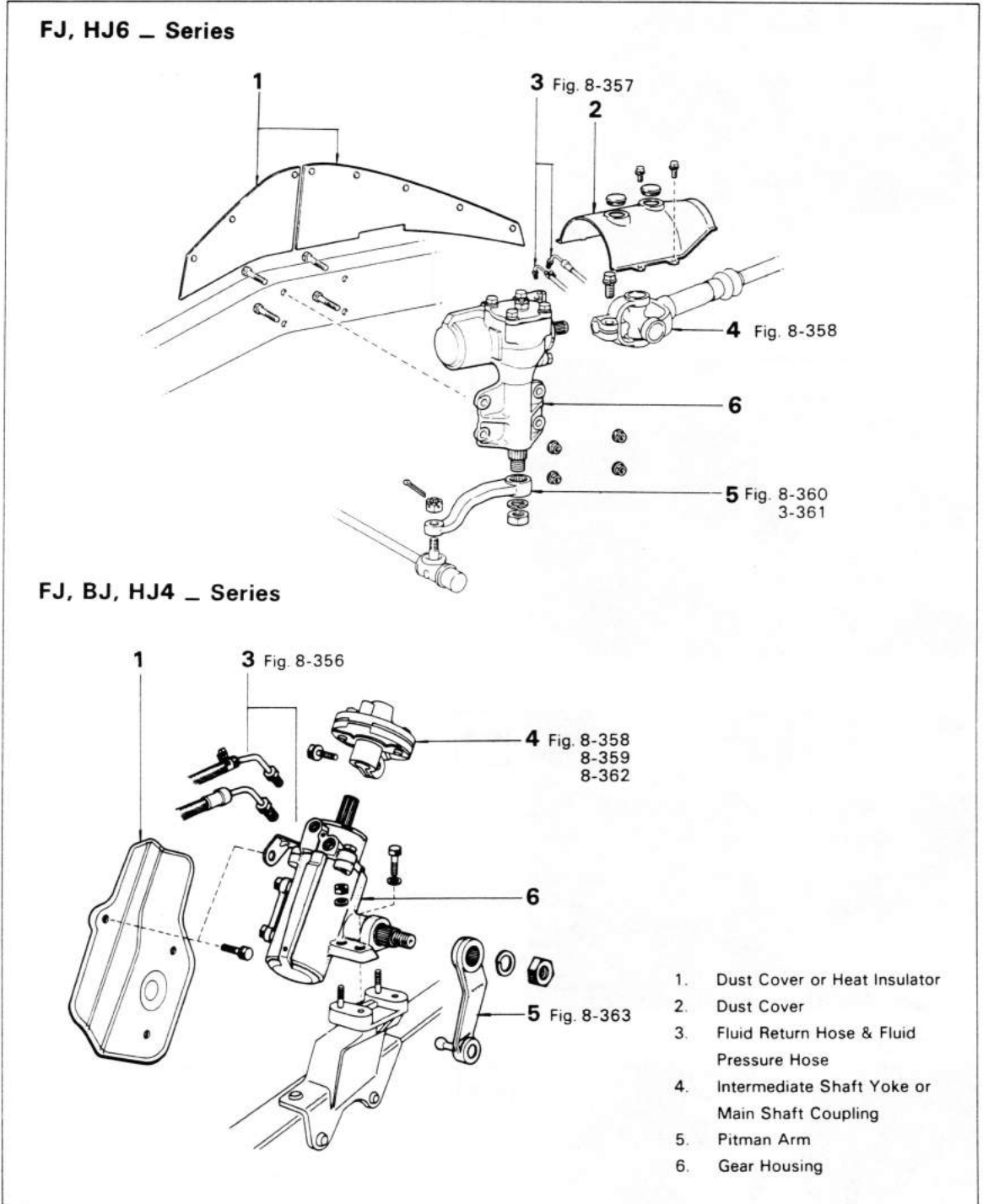
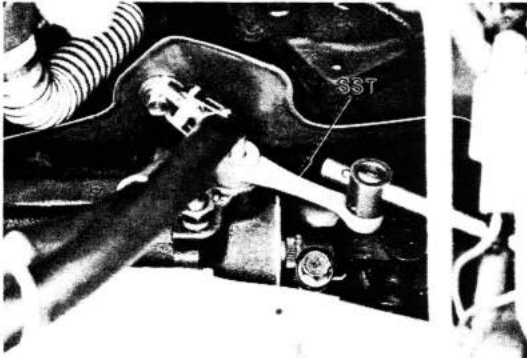
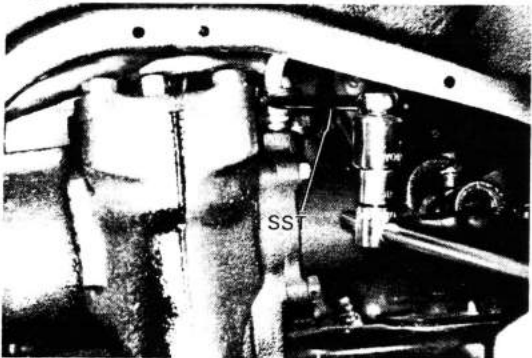

Fig. 8-356



Disconnect the return hose with SST.
SST [09631-22020]

Fig. 8-357



Disconnect the pressure hose with SST.
SST [09631-22020]

Fig. 8-358

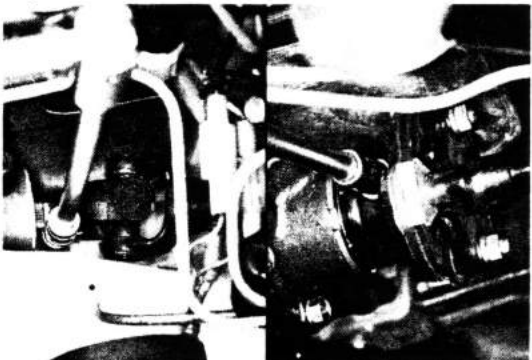

Remove the coupling set bolt.

Fig. 8-359

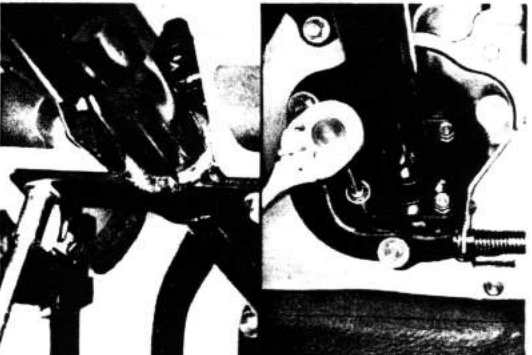

Remove the steering column tube set bolts.
Loosen the upper bracket set bolts.

Fig. 8-360

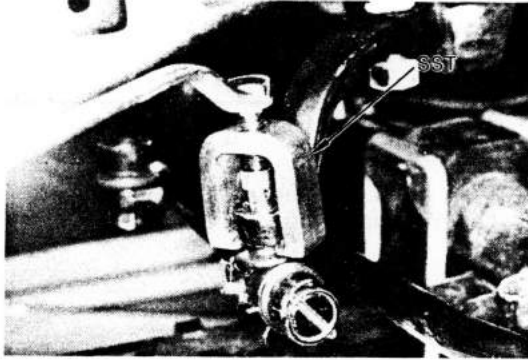

Disconnect the relay rod with SST.
SST [09611-20014]

Fig. 8-361

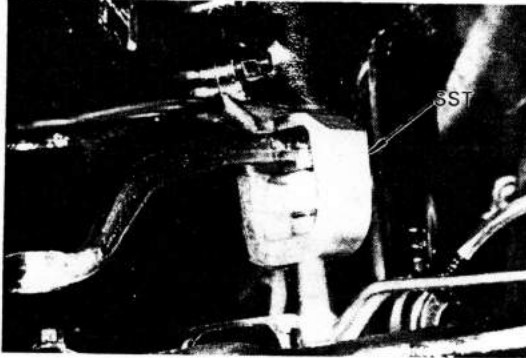

Remove the pitman arm with SST.
SST [09610-55012]

Fig. 8-362



Remove the coupling from the steering gear housing.

Fig. 8-363

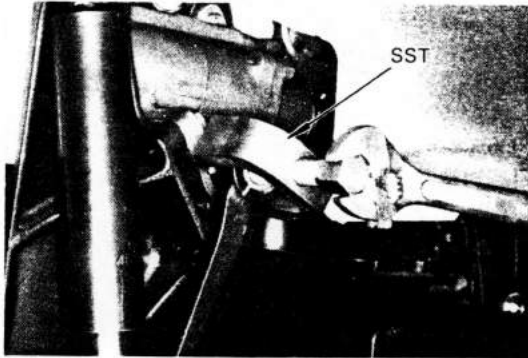

Remove the pitman arm with SST.
SST [09610-55012]

DISASSEMBLY

Disassemble the parts in the numerical order shown in the figure.

Fig. 8-364

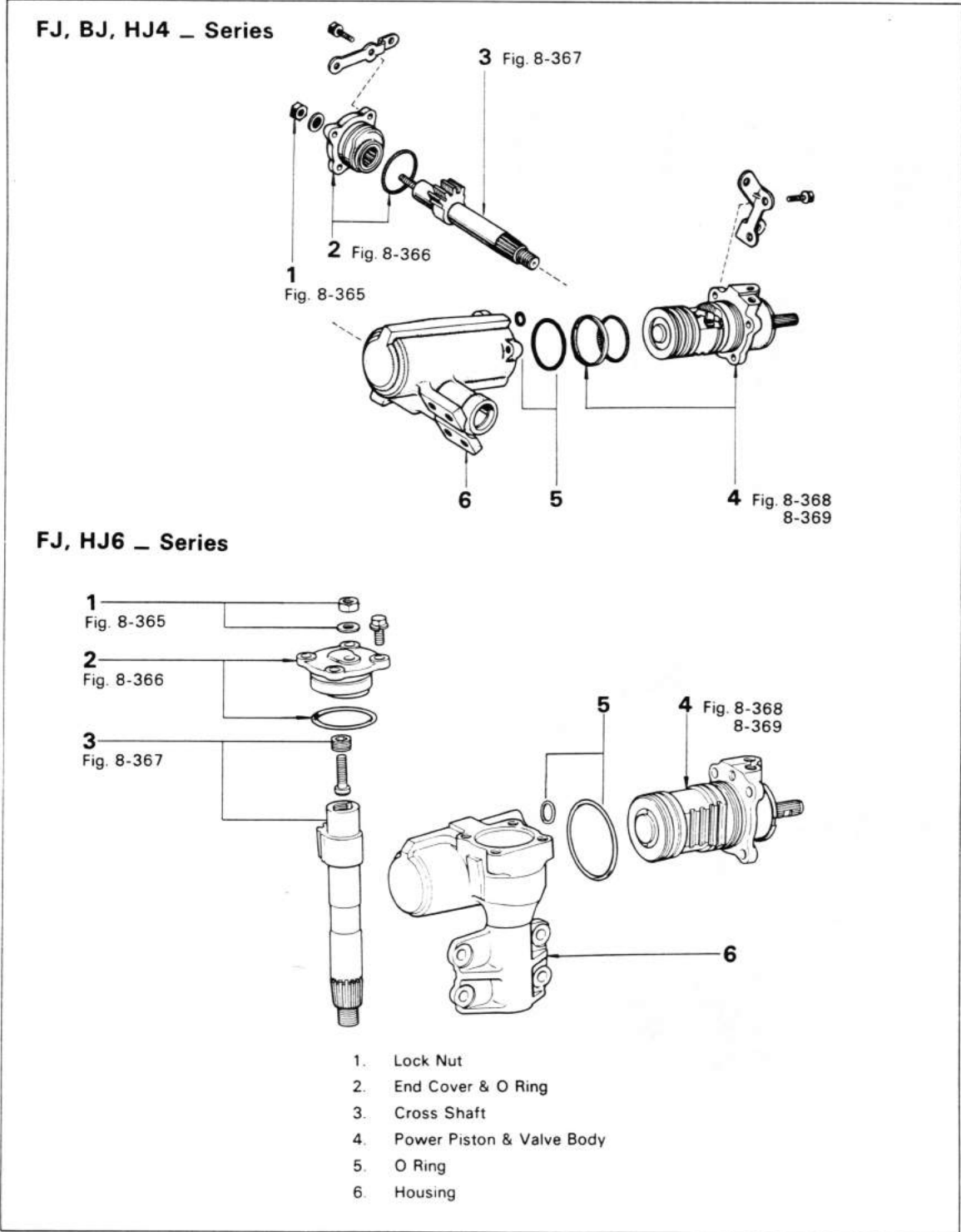
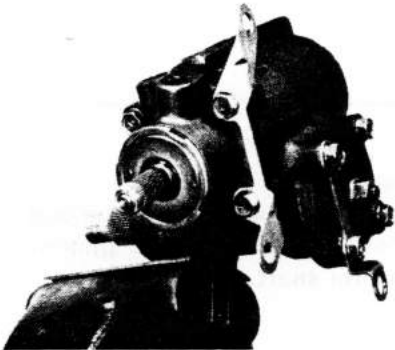
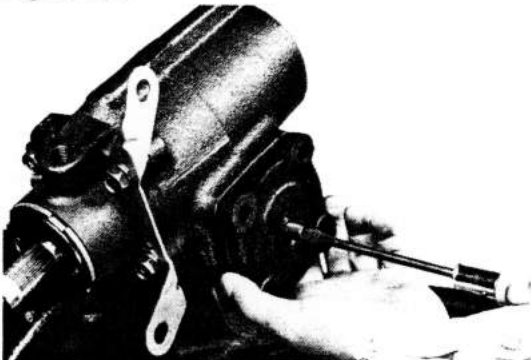

Fig. 8-365



Clamp the gear housing in a vice.

Fig. 8-366



Tighten the adjusting screw until the end cover and O ring are removed from the housing.

Fig. 8-367

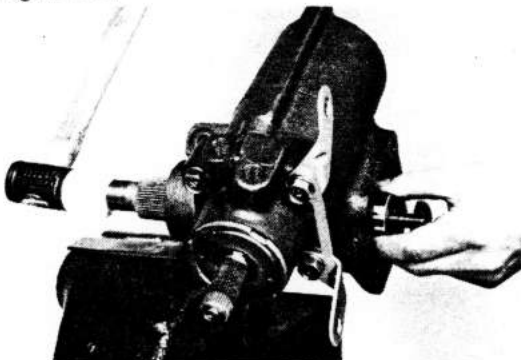

Remove the cross shaft by tapping the bottom end with a hammer.

Fig. 8-368



Hold the power piston with your finger and turn the worm shaft clockwise. Then pull out the valve body and power piston.

Fig. 8-369

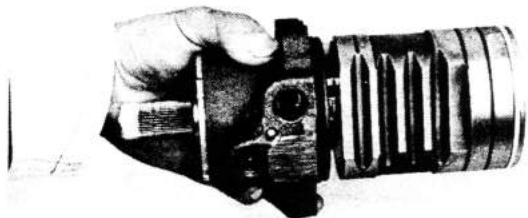

— Note —

Do not disassemble the valve body.

Do not remove the power piston nut from
the worm shaft.

Fig. 8-370

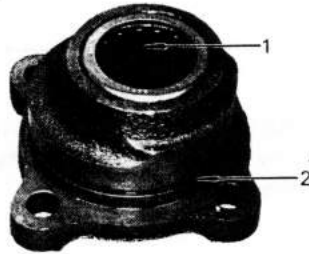

INSPECTION & REPAIR



End Cover

Inspect the following for wear or damage.

1. Needle roller bearing
2. O ring groove

Fig. 8-371

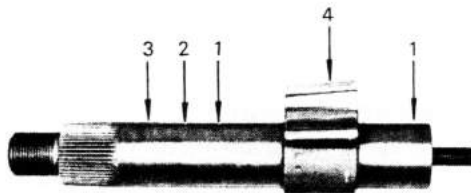

Cross Shaft

Inspect the following for wear or damage.

1. Needle roller bearing running surface
2. Teflon ring contact surface
3. Dust seal contact surface
4. Power piston nut gear tooth contact surface

Fig. 8-372

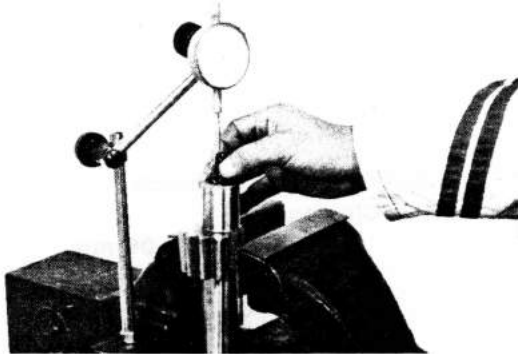

Adjust The Cross Shaft Adjusting Screw

1. Measure the thrust clearance of the adjusting screw.

Clearance: 0.03–0.05 mm
(0.0012–0.0020 in.)

Fig. 8-373

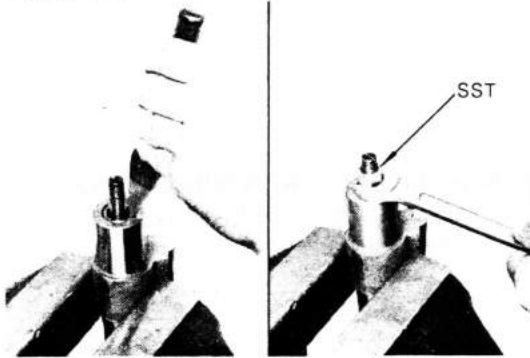

2. Unstake the lock nut.
3. Loosen the lock nut with SST.
SST (09632-00030) of set [09630-00010]

cardiagn.com

Fig. 8-374

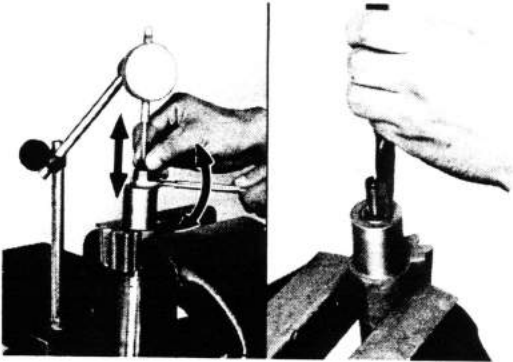

4. Adjust the clearance of the adjusting screw by turning the lock nut.
5. Stake the lock nut.

Fig. 8-375

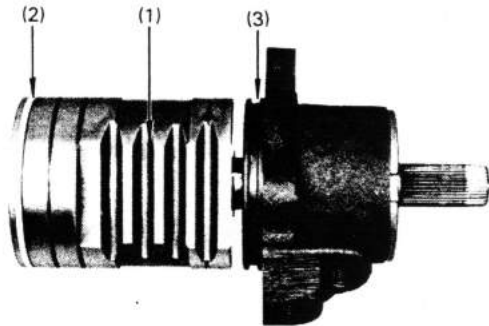
**Power Piston Nut**

1. Inspect the following for wear or damage.
 - (1) Cross shaft gear tooth contact surface
 - (2) Teflon ring
 - (3) O ring groove

Fig. 8-376

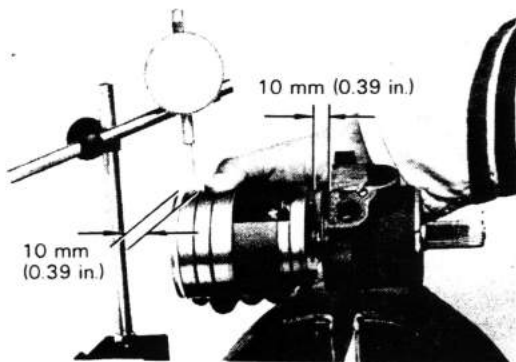

2. Measure the ball clearance.

Clearance:

STD	0.02–0.06 mm (0.0008–0.0024 in.)
Limit	0.15 mm (0.0059 in.)

Fig. 8-377

**Adjusting Plug & Worm Bearing**

1. Support the valve body by installing it to the gear housing.

Fig. 8-378

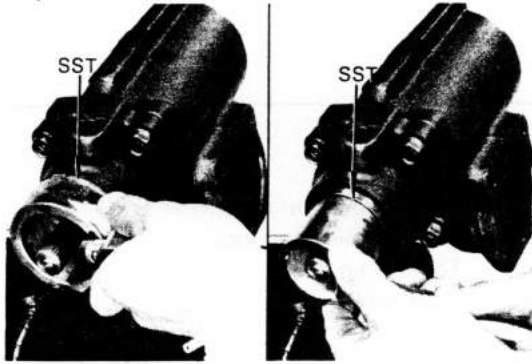

2. Remove the lock nut with SST.
SST (09631-00040) of set [09630-00010]
3. Remove the adjusting plug with SST.
SST (09631-00050) of set [09630-00010]

Fig. 8-379

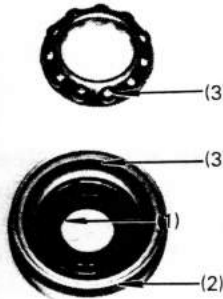
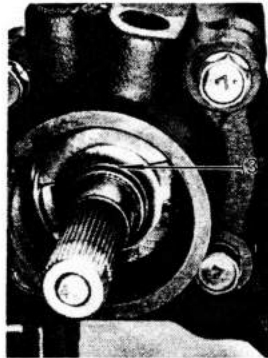

4. Inspect the following for wear or damage.
 - (1) Oil Seal
 - (2) O ring contact surface
 - (3) Bearing

Fig. 8-380

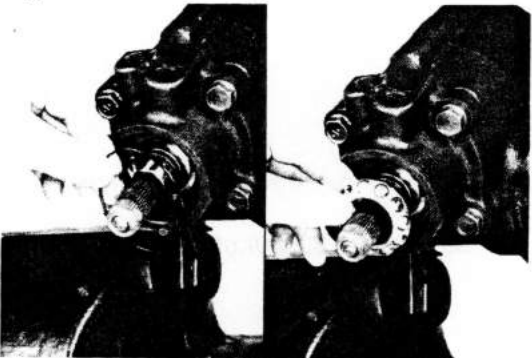

5. Install the adjusting plug provisionally.
 - (1) Use a new O ring.
 - (2) Install the bearing.

Fig. 8-381



- (3) Install the adjusting plug provisionally with SST.
SST (09631-00050) of set [09630-00010]
- (4) Remove the valve body and the power piston nut from the gear housing.

Fig. 8-382

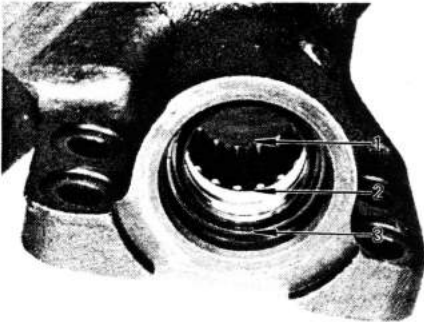

Gear Housing

Inspect the following for wear or damage.

1. Needle roller bearing
2. Teflon ring
3. Dust seal

Fig. 8-383

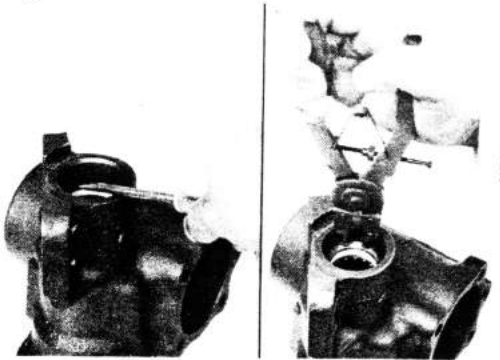

Replace The Needle Roller Bearing

1. Remove the dust seal with a screwdriver.
2. Remove the snap ring.
3. Remove the teflon ring.

Fig. 8-384

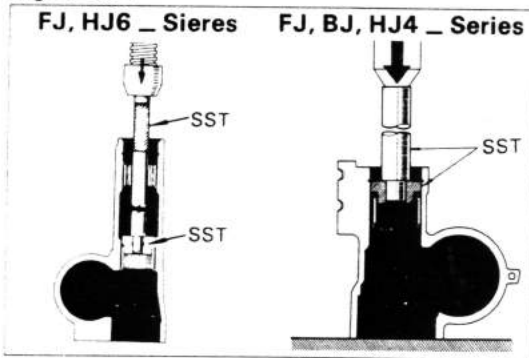

4. Remove the needle roller bearing with SST.
SST (09631-00080) of set [09630-00010]

Fig. 8-385

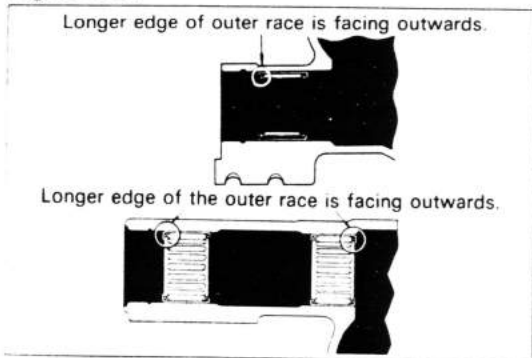

5. Install the needle roller bearing with the longer edge of the outer race facing outwards.

Fig. 8-386

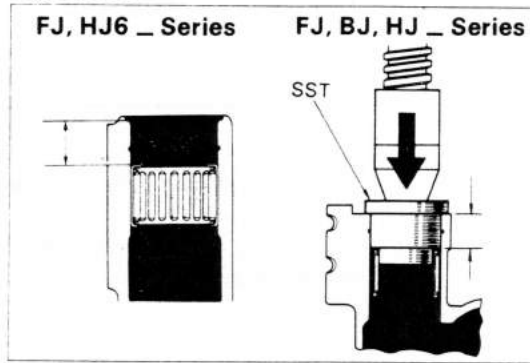

6. Install the needle roller bearing with SST. SST (09631-00090) of set [09630-00010] [09631-60010] FJ, HJ6 _ series
FJ, HJ4 _ series

Installed position:

- FJ, HJ6 _ Series**
23.1 mm (0.909 in.)
FJ, HJ4 _ Series
23.6 mm (0.929 in.)

Fig. 8-387

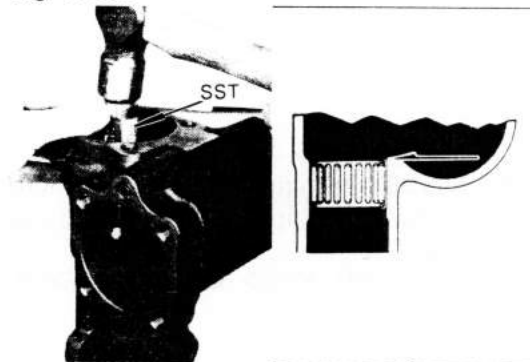

7. The bearing top end should be installed so that it aligns with the housing end surface.
SST (09631-00090) of set [09630-00010]

Fig. 8-388

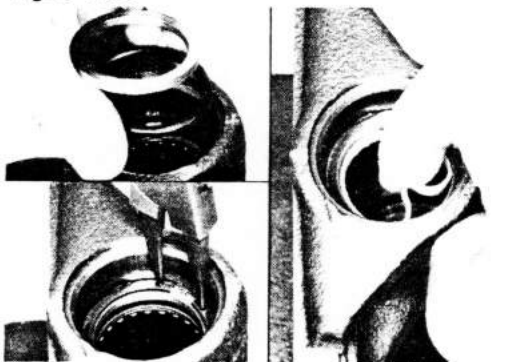

8. Install the teflon ring and O ring.
FJ, HJ6 _ series
(1) Install the O ring, spacer and snap ring.
(2) Form the teflon ring into a heart shape and install with your finger.

Fig. 8-389

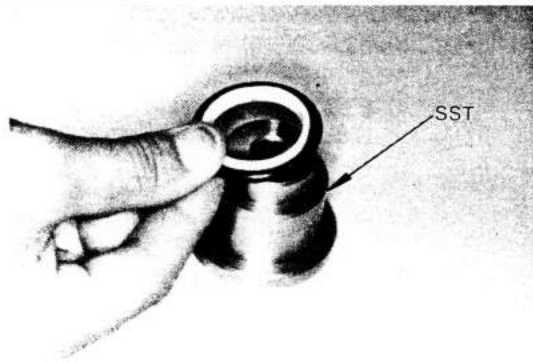

- FJ, HJ4 _ Series
(1) Install the teflon ring together the O ring to SST.
SST [09631-60010]
(2) Install SST together with the rings to the gear housing.
SST [09631-60010]

Fig. 8-390

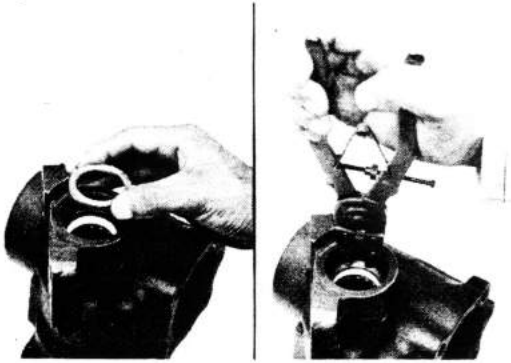

- (3) Install the steel ring and the snap ring.
Confirm that the steel ring can be turned by hand.

Fig. 8-391

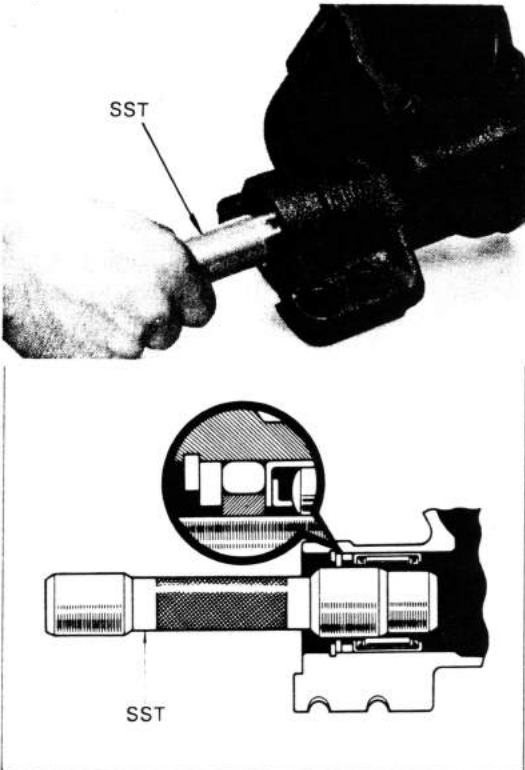

9. Rub SST along the inside of the teflon ring so that it will fit smoothly over the cross shaft.
SST (09631-00060) of set [09630-00010]

Fig. 8-392

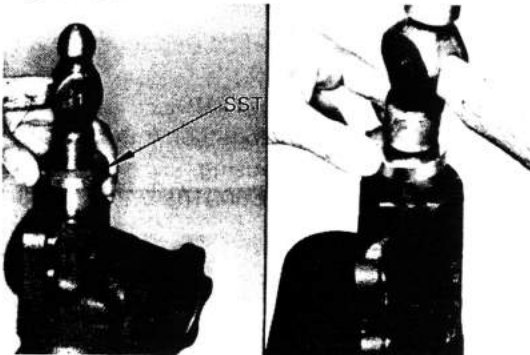

10. Install the dust seal with SST.
SST (09631-00010) of set [09630-00010]
FJ, HJ6 _ series
[09631-60010] FJ, HJ4 _ series

ASSEMBLY

Assemble the parts in the numerical order shown in the figure.

Fig. 8-393

FJ, BJ, HJ4 — Series

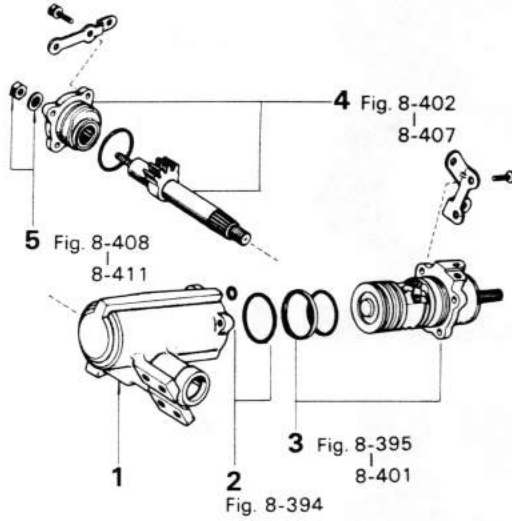

FJ, HJ6 — Series

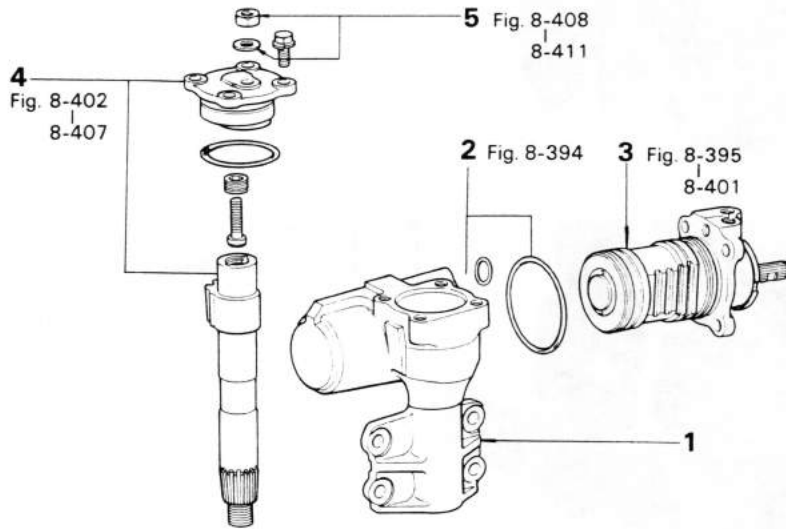

- 1. Housing
- 2. O Ring
- 3. Power Piston & Valve Body
- 4. End Cover, O Ring & Cross Shaft
- 5. Lock Nut & Seal Washer

Fig. 8-394



Fit the O ring accurately.

Fig. 8-395

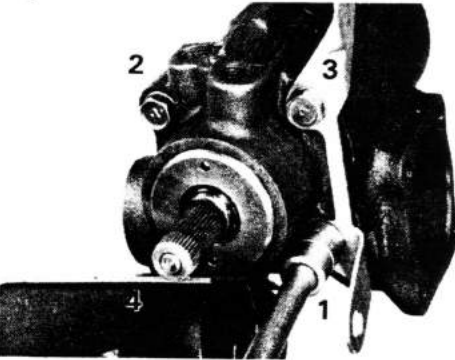

Tighten the bolts diagonally and evenly in two or three rotations.

Fig. 8-396

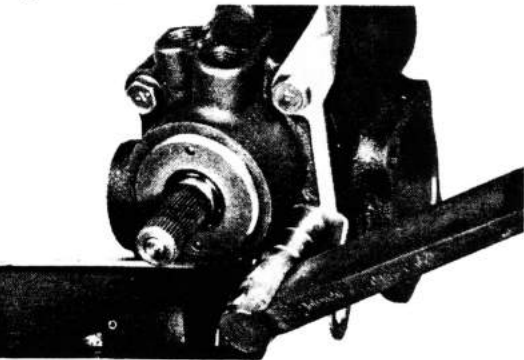

Tighten the valve body.

Tightening torque: 4.0 – 5.5 kg-m
(29 – 39 ft-lb)

Fig. 8-397

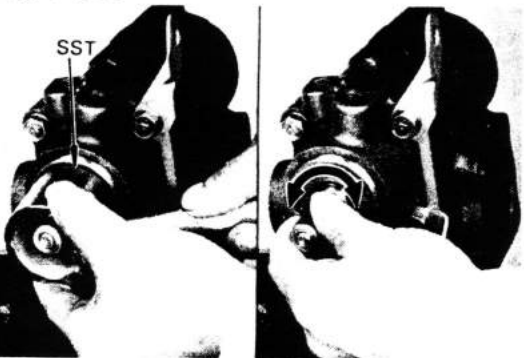

Adjust the preload of the worm shaft.

1. Tighten the adjusting plug with SST. SST (09631-00050) of set [09630-00010]
2. Turn the worm shaft to check the turning condition.

Fig. 8-398



- Loosen the adjusting plug with SST to adjust the preload.
SST (09631-00050) of set [09630-00010]

Fig. 8-399

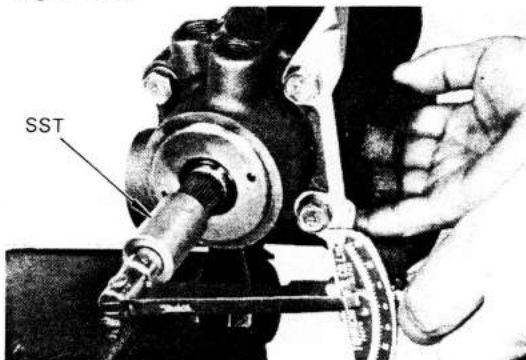

- Insert SST into the serrated section of the worm shaft, and measure the preload with a torque meter.
SST [09616-00010]

Preload (starting):

4.0 – 6.5 kg-cm
(3.5 – 5.6 in.-lb)

– Note –

Hold the power piston nut to prevent it from turning.

Fig. 8-400

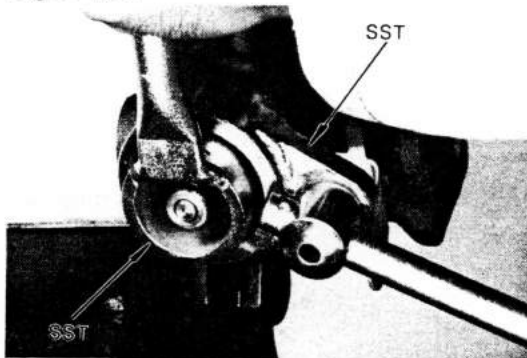

- Tighten the lock nut with SST.
SST (09631-00050) of set [09630-00010]
(09631-00040) of set [09630-00010]

Tightening torque:

4.5 – 5.5 kg-m
(33 – 39 ft-lb)

Fig. 8-401

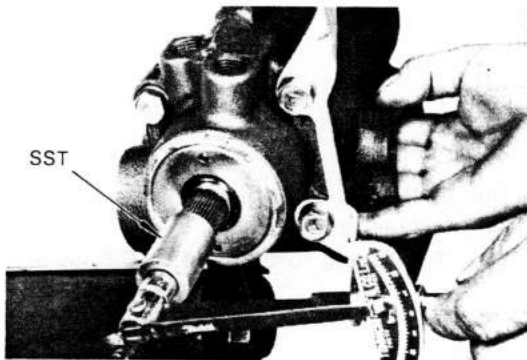

- Recheck the preload. Check to see that both the right and left rotations are identical.
SST [09616-00010]

Fig. 8-402

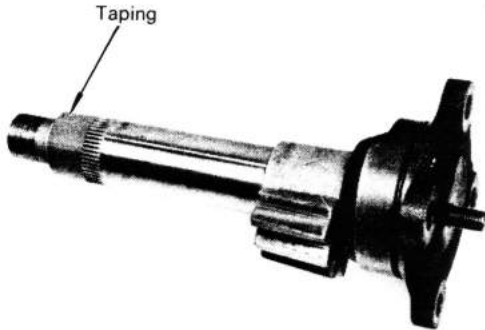

Wrap vinyl tape around the spline area of the cross shaft and loosen the adjusting screw fully.

Fig. 8-403

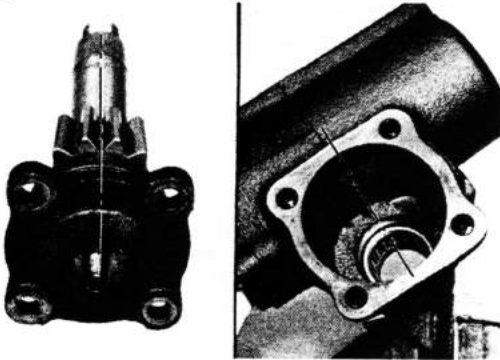

Align the cross shaft gear center with that of the power piston nut gear.

Fig. 8-404



Never turn the cross shaft, as this may cause O ring damage.

Fig. 8-405

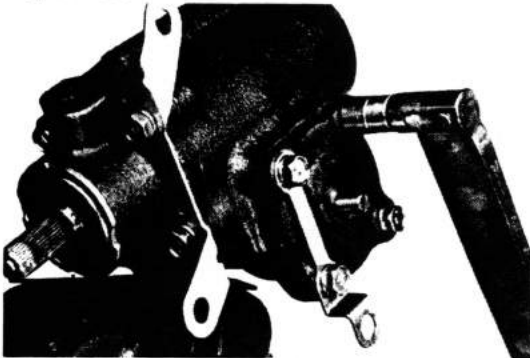

Tighten the end cover diagonally and evenly in two or three rotations.

**Tightening torque: 4.0–5.5 kg-m
(29–39 ft-lb)**

Fig. 8-406

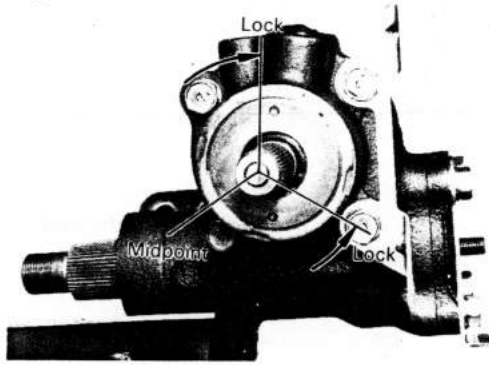

Adjust the cross shaft preload.

1. Set worm shaft to midpoint position. Determine total number of the worm shaft turns and return from full lock by half that number.

Fig. 8-407

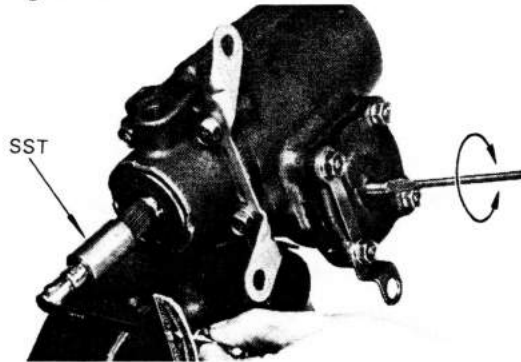

2. Insert SST into the serrated section of the worm shaft.

Turn the adjusting screw, and measure preload with a torque meter.

SST [09616-00010]

Preload (starting):

Worm shaft preload plus
2 – 3 kg-cm
(1.8 – 2.6 in.-lb)

Fig. 8-408



3. Use a new seal washer.

Fig. 8-409

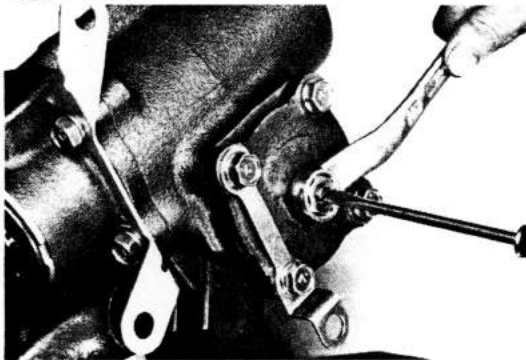

4. Tighten the lock nut.

Tightening torque:

4.0 – 5.5 kg-m
(29 – 39 ft-lb)

Fig. 8-410



5. Recheck the preload.
Check to see that both the right and left rotations are identical.
SST [09616-00010]

Fig. 8-411



6. Stake at three points.

INSTALLATION

Install the parts in the numerical order shown in the figure.

Fig. 8-412

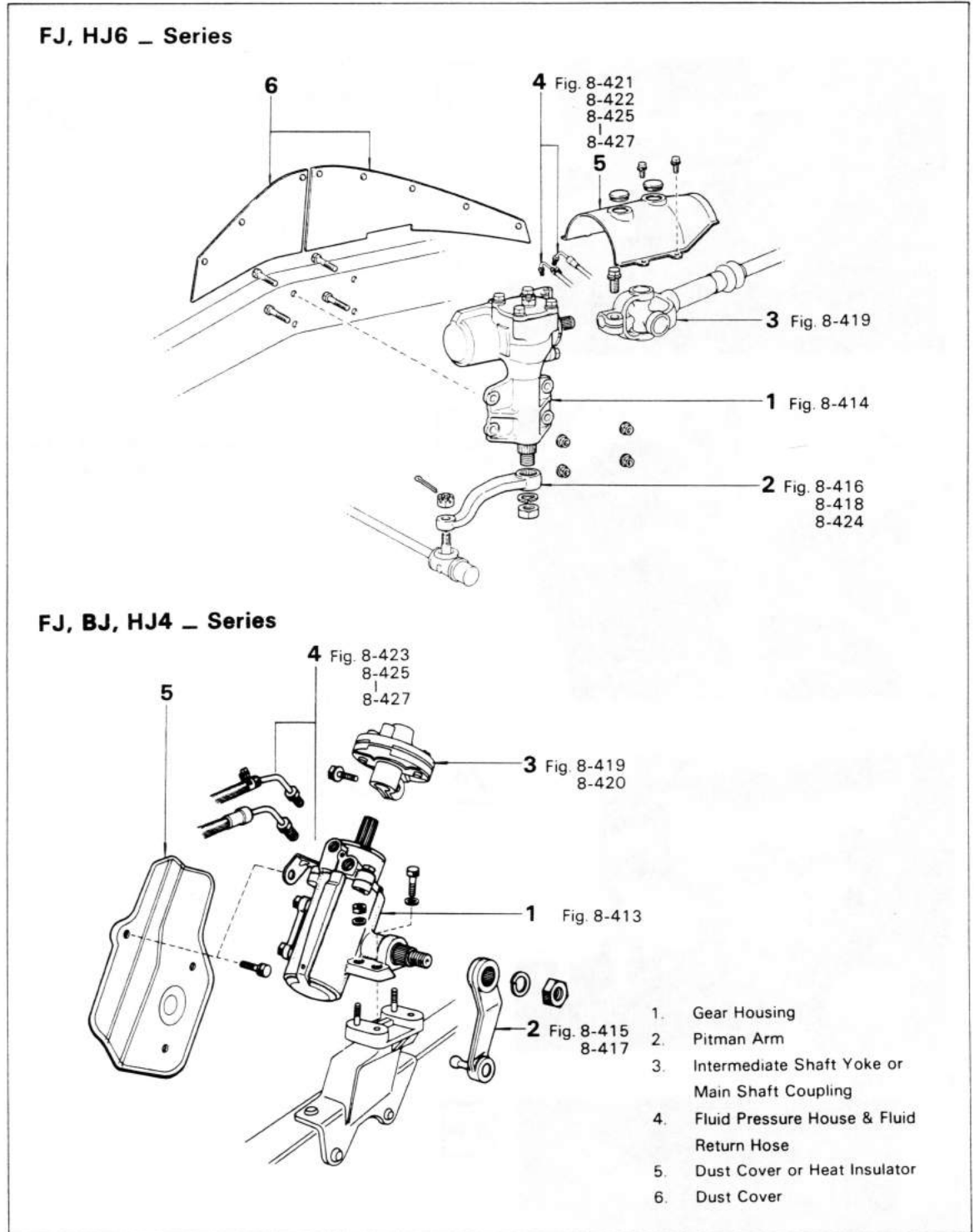
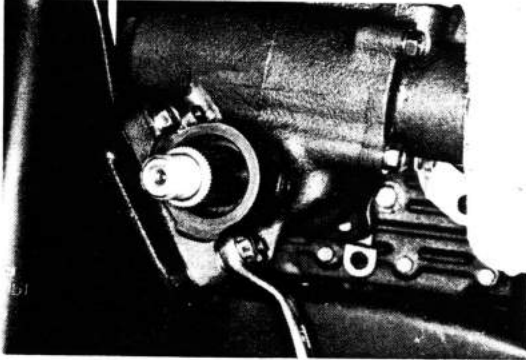

Fig. 8-413



Tighten the gear housing set bolts and nuts.

**Tightening torque: 5.5 – 8.8 kg-m
(40 – 63 ft-lb)**

Fig. 8-414

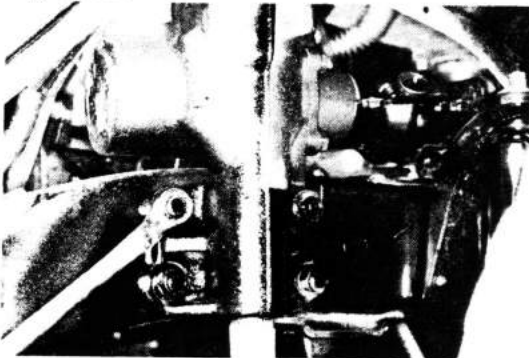

Tighten the gear housing set bolts and nuts.

**Tightening torque: 5.5 – 8.8 kg-m
(40 – 63 ft-lb)**

Fig. 8-415

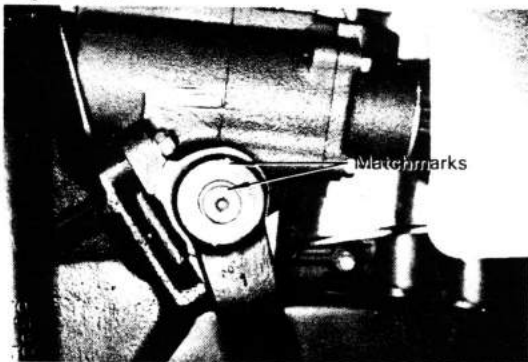

Align the matchmarks on the pitman arm and the cross shaft.

Fig. 8-416

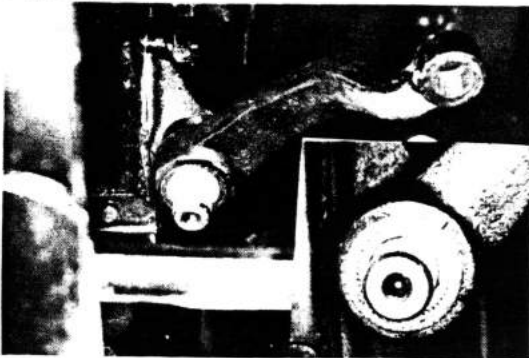

Align the matchmarks on the pitman arm and the cross shaft.

Fig. 8-417

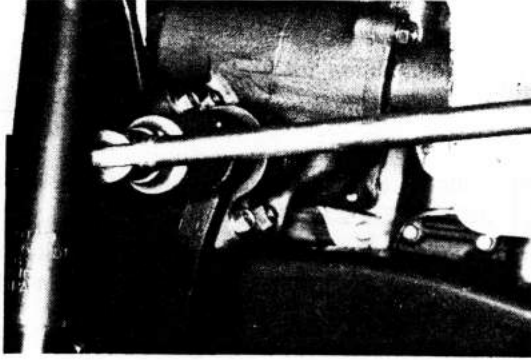

Tighten the pitman arm set nut.

Tightening torque:
16.5 – 19.5 kg-m
(120 – 141 ft-lb)

Fig. 8-418

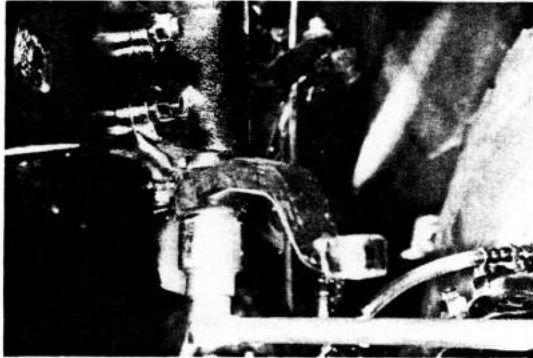

Tighten the pitman arm set nut.

Tightening torque:
16.5 – 19.5 kg-m
(120 – 141 ft-lb)

Fig. 8-419

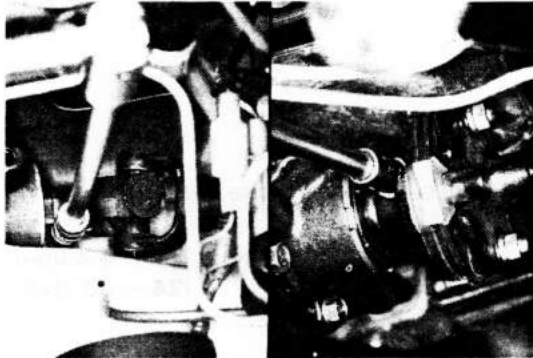

Tighten the coupling set bolt.

Tightening torque: **3.0 – 4.5 kg-m**
(22 – 32 ft-lb)

Fig. 8-420

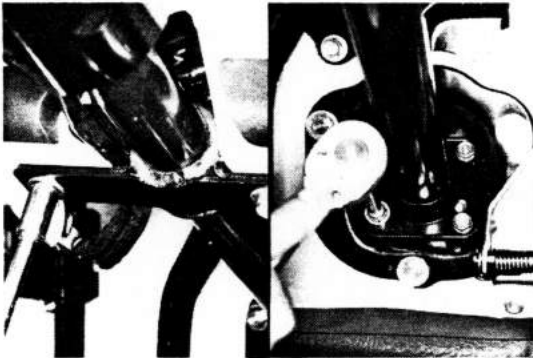

Install the steering column tube.

Fig. 8-421

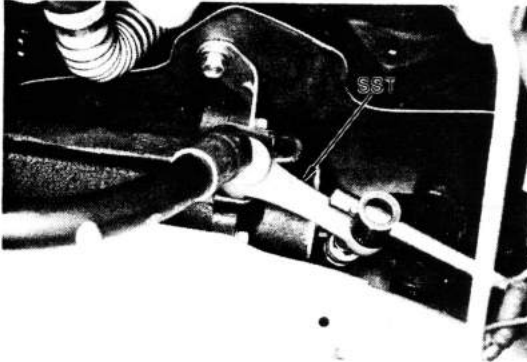

Connect the pressure hose with SST.
SST [09631-22020]

Tightening torque: 4.0 – 5.0 kg-m
(29 – 36 ft-lb)

Fig. 8-422

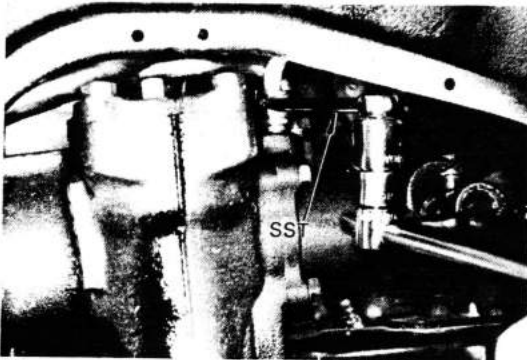

Connect the pressure hose with SST.
SST [09631-22020]

Tightening torque: 4.0 – 5.0 kg-m
(29 – 36 ft-lb)

Connect the return pipe with SST.
SST [09631-22020]

Tightening torque: 3.2 – 4.2 kg-m
(24 – 30 ft-lb)

Fig. 8-423

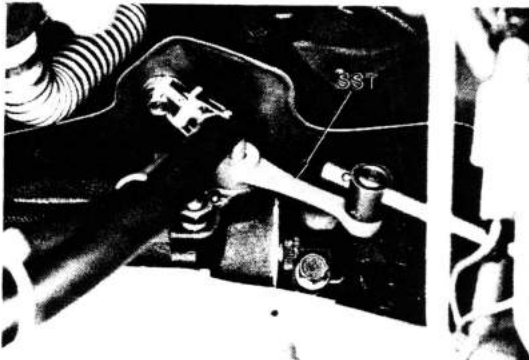

Connect the return hose with SST.
SST [09631-22020]

Tightening torque: 3.2 – 4.2 kg-m
(24 – 30 ft-lb)

Fig. 8-424

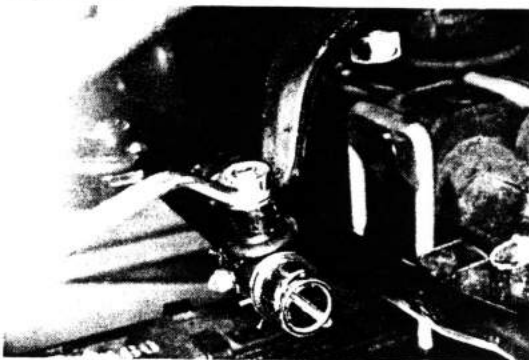

Connect the relay rod.

Fig. 8-425

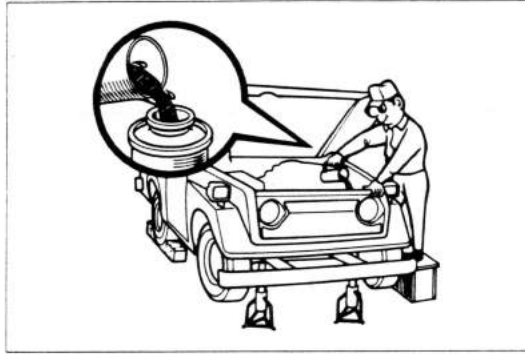

Fill with fluid.

Fluid: ATF type Dexron
Capacity: Gear housing 330 cc
(20.1 cu in.)

Fig. 8-426

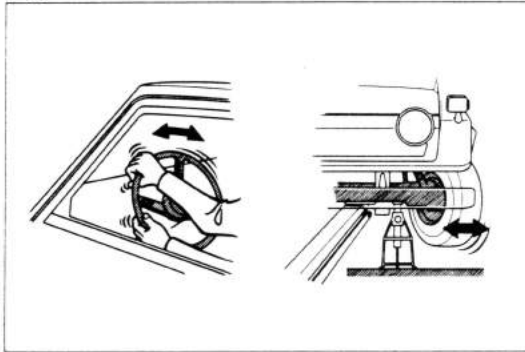

Bleed the system.

Fig. 8-427

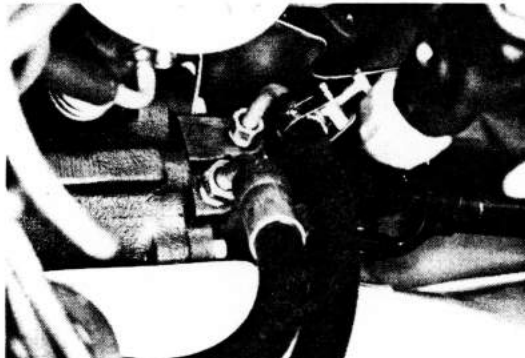

Boost the fluid pressure to check for fluid leakage.