FUEL SYSTEM

	Page
PRECAUTIONS.....	FU-2
TROUBLESHOOTING	FU-2
ON-VEHICLE INSPECTION	FU-3
CARBURETOR	FU-4
FUEL PUMP.....	FU-28

FU

PRECAUTIONS

1. Before working on the fuel system, disconnect the cat from the negative battery terminal.
2. When working on the fuel system, keep away from possible fire hazards and do not smoke.
3. Keep gasoline off rubber or leather parts.
4. Work on only one component group at a time to avoid confusion between similar looking parts.
5. Keep work area clean to avoid contamination of the carburetor and components.
6. Be careful not to mix up or lose clips or springs.

TROUBLESHOOTING

Problem	Possible cause	Remedy	Page
Engine will not start/ Hard to start (cranks ok)	Carburetor problems <ul style="list-style-type: none"> • Choke operating • Flooding • Needle valve sticking or clogged • Vacuum hose disconnected or damaged • Fuel cut solenoid valve not open 	Repair as necessary	FU-4
Rough idle or stalls	Carburetor problems <ul style="list-style-type: none"> • Idle speed incorrect • Slow jet clogged • Idle mixture incorrect • Fuel cut solenoid valve not open • Fast idle speed setting incorrect (cold engine) • Choke system faulty • Secondary throttle valve not closed 	Perform on-vehicle inspection of carburetor	FU-3
Engine hesitates/ Poor acceleration	Fuel line clogged Carburetor problems <ul style="list-style-type: none"> • Float level too low • Accelerator pump faulty • Power valve faulty • Choke valve closed (hot engine) • Choke system 	Check fuel line Repair as necessary	FU-4
Engine dieseling (runs after ignition switch is turned off)	Carburetor problems <ul style="list-style-type: none"> • Linkage sticking • Idle speed or fast idle speed out of adjustment • Fuel cut solenoid faulty 	Repair as necessary	FU-4
Poor gasoline mileage	Fuel leak Carburetor problems <ul style="list-style-type: none"> • Choke faulty • Idle speed too high • Deceleration fuel cut system faulty • Power valve always open 	Repair as necessary Perform on-vehicle inspection of carburetor	FU-3
Insufficient fuel supply to carburetor	Fuel filter clogged Fuel pump faulty Fuel line clogged Fuel line bent or kinked	Replace fuel filter Replace fuel pump Check fuel line Replace fuel line	FU-28 FU-30

ON-VEHICLE INSPECTION

1. **REMOVE AIR CLEANER** (See page FU-5)
2. **CHECK CARBURETOR AND LINKAGE**
 - (a) Check that the various set screws, plugs and union bolts are tight and installed correctly.
 - (b) Check the linkage for excessive wear and missing snap rings.
 - (c) Check that the throttle valves open fully when the accelerator pedal is fully depressed.

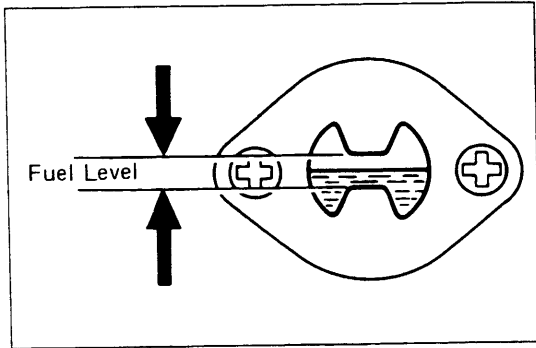

3. CHECK FLOAT LEVEL

Check that the fuel level is about even with the correct level in the sight glass.

If not, check the carburetor needle valve and float level, and adjust or repair, as necessary.

COLD ENGINE

4. **CHECK AUTOMATIC CHOKE** (See page EC-55)
5. **CHECK CHOKE OPENER** (See page EC-58)
6. **CHECK CHOKE BREAKER** (See page EC-57)
7. **CHECK AAP SYSTEM** (See page EC-61)
8. **CHECK OUTER VENT CONTROL VALVE**

HOT ENGINE

9. **CHECK AUTOMATIC CHOKE** (See page EC-55)
10. **CHECK CHOKE OPENER** (See page EC-58)
11. **CHECK AAP SYSTEM** (See page EC-61)
12. **CHECK ACCELERATION PUMP**
Open the throttle valve, and check that gasoline spurts out from the acceleration nozzle.
13. **CHECK FUEL CUT SYSTEM** (See page EC-63)
14. **INSTALL AIR CLEANER** (See page FU-24)
15. **CHECK AND ADJUST THE IDLE SPEED**
(See page FU-24)
16. **CHECK AND ADJUST FAST IDLE SPEED**
(See page FU-22)

CARBURETOR COMPONENTS

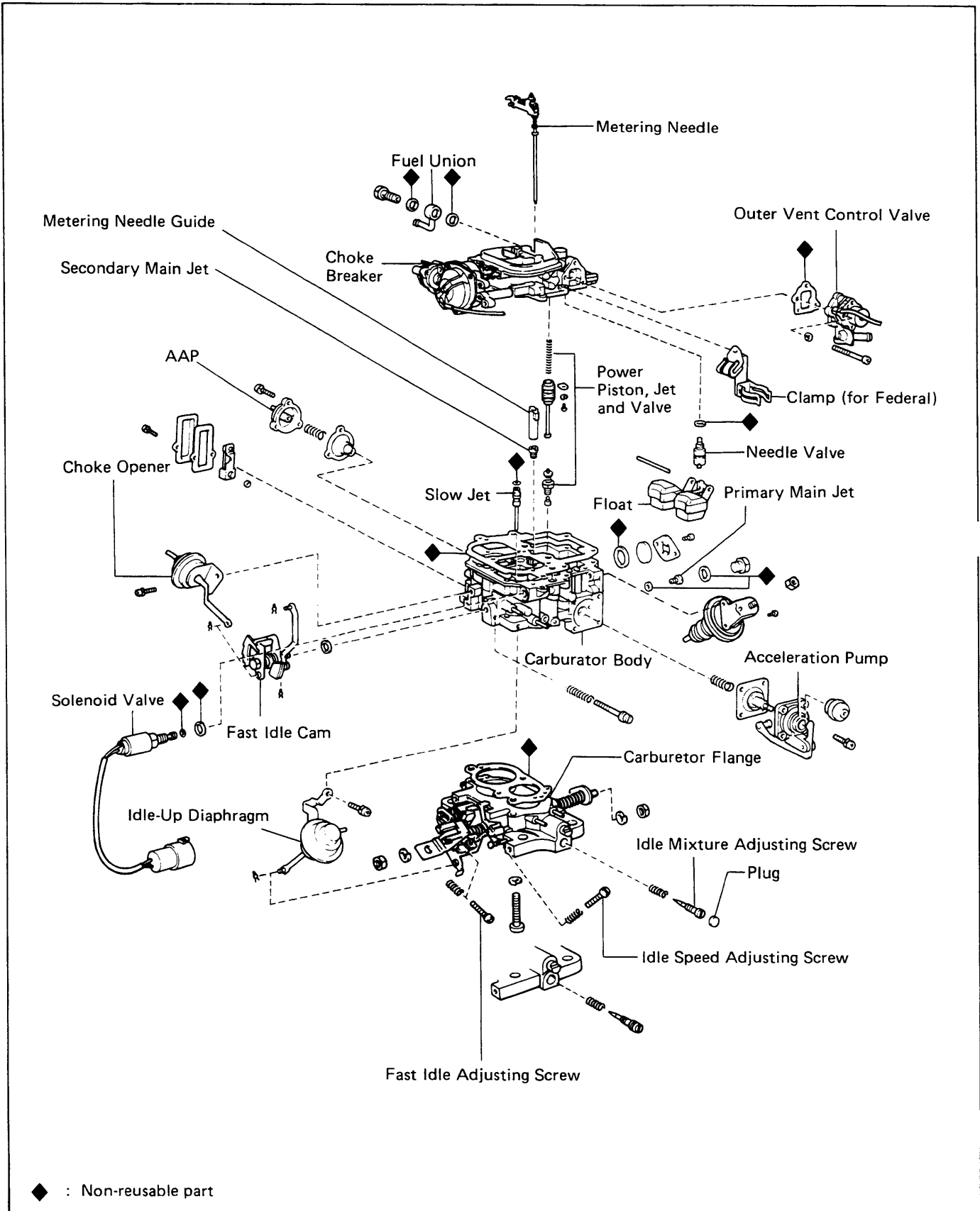

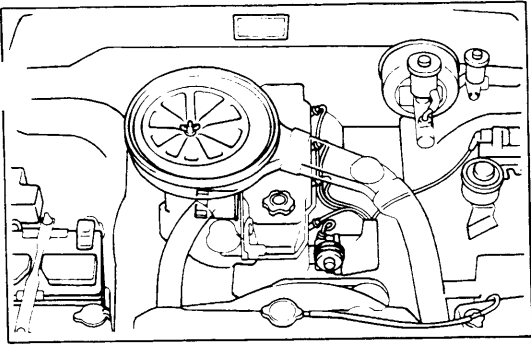

REMOVAL OF CARBURETOR

1. REMOVE AIR CLEANER

- (a) Disconnect the emission control hoses.
- (b) Disconnect the air intake hose.
- (c) Remove the two mounting nuts and butterfly nut.
- (d) Lift the air cleaner off the carburetor.

2. DISCONNECT THROTTLE CABLE FOR AUTOMATIC TRANSMISSION (See page AT-20)

3. DISCONNECT FOLLOWING HOSES FROM CARBURETOR

- (a) Emission control hoses
- (b) PCV hose from the flange
- (c) Fuel hose
- (d) Wiring connector

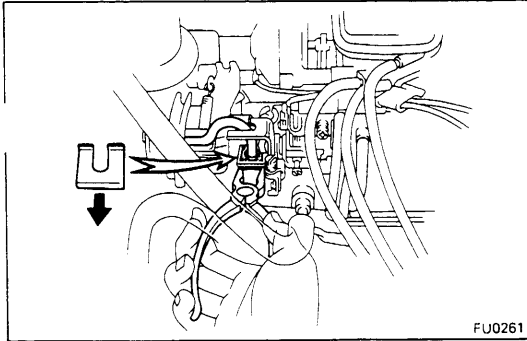

FU0261

4. DISCONNECT ACCELERATOR LINKAGE

5. REMOVE CARBURETOR

- (a) Remove the carburetor mounting bolts and nuts.
- (b) Lift out the carburetor.
- (c) Cover the inlet hole of the intake manifold with a cloth.

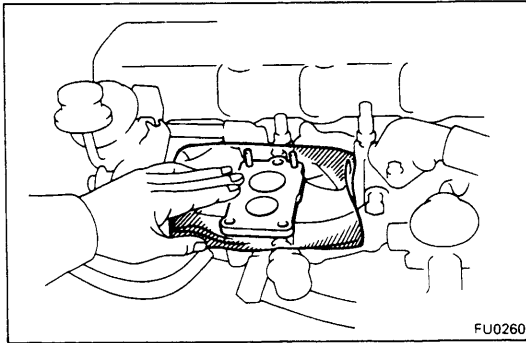

FU0260

DISASSEMBLY OF CARBURETOR

(See page FU-4)

The following instructions are organized so that you work on only one component group at a time. This will help avoid confusion from similar looking parts from different sub-assemblies being on your workbench at the same time.

- (a) To facilitate reassembly, arrange parts in order.
- (b) Be careful not to mix up or lose clips or springs.
- (c) Use SST (Carburetor Driver Set).

SST 09860-11011

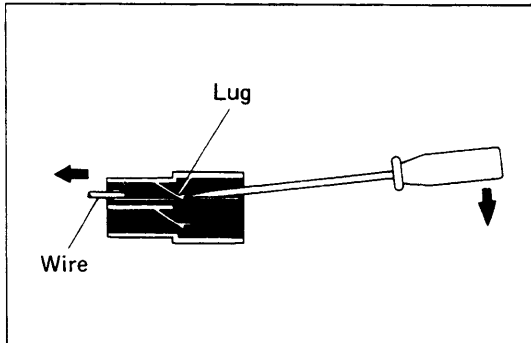

Disassembly of Air Horn

(See page FU-4)

1. DISCONNECT TERMINAL FROM CONNECTOR

Pry up the locking lugs with a screwdriver and pull out the terminals.

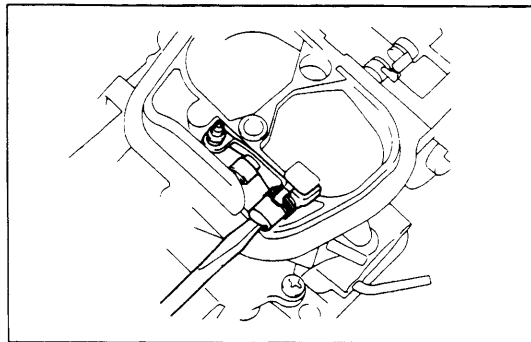

2. REMOVE METERING NEEDLE

Loosen the screw and remove the metering needle.

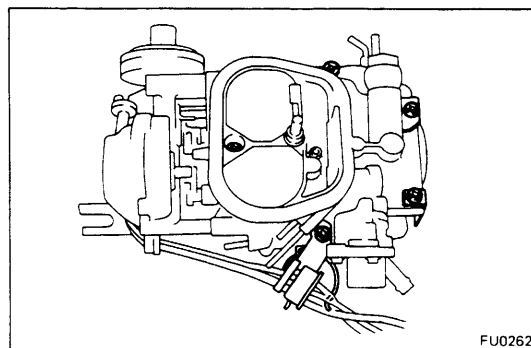

3. REMOVE AIR HORN ASSEMBLY

- (a) Disconnect the fast idle link and air valve connecting rod.
- (b) Remove the five air horn screws and lift the air horn from the body.
- (c) Remove the air horn gasket.

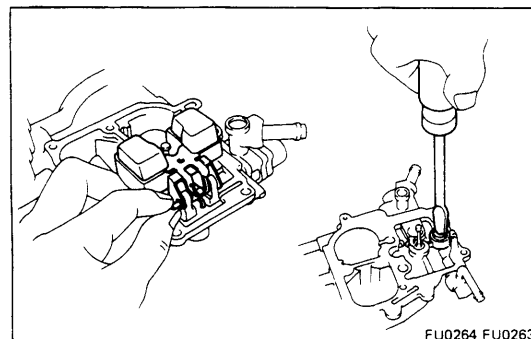

4. REMOVE FLOAT AND NEEDLE VALVE

- (a) Remove the pivot pin and float with the needle valve.
- (b) Remove the needle valve seat.

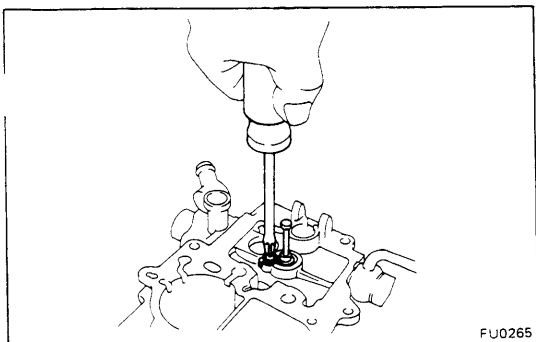
**5. REMOVE POWER PISTON**

- (a) Loosen the retainer screw.
- (b) While holding the piston, rotate the retainer.
- (c) Remove the power piston and spring.

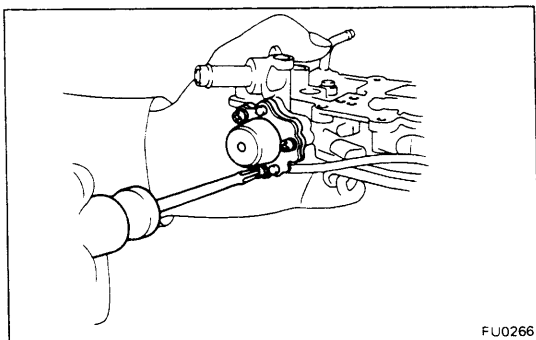
**6. REMOVE OUTER VENT CONTROL VALVE**

Loosen the three screws and remove the outer vent control valve.

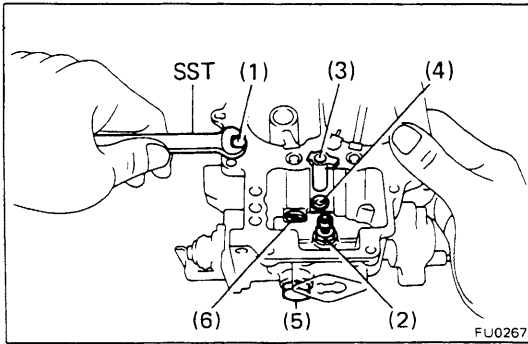

Disassembly of Carburetor Body

1. REMOVE DASH POT WITH BRACKET (FOR A/T)

2. REMOVE JETS AND POWER VALVE

(a) Using SST, remove the slow jet (1).

SST 09922-00010

(b) Remove the power valve with jet (2).

(c) Remove the metering needle guide (3) and secondary main jet (4).

(d) Remove the plug (5) and primary main jet (6).

3. REMOVE FUEL CUT SOLENOID VALVE

Remove the solenoid valve from the carburetor body.

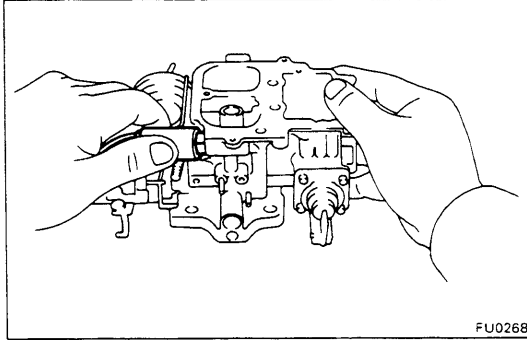

4. REMOVE ACCELERATION PUMP

Remove the four screws, pump housing, diaphragm and spring.

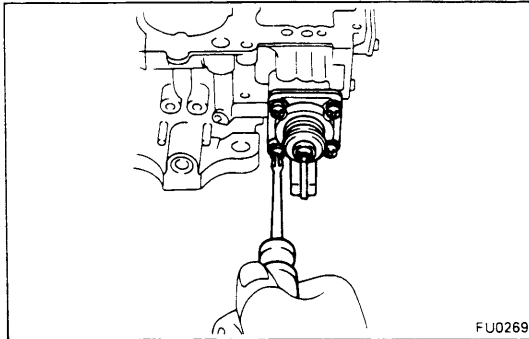

5. REMOVE AUXILIARY ACCELERATION PUMP

Remove the three screws, pump housing, spring and diaphragm.

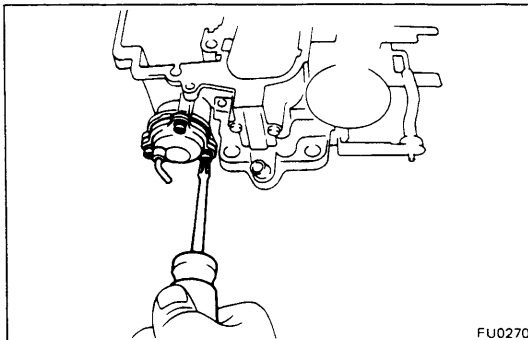

6. REMOVE IDLE-UP DIAPHRAGM

(a) Disconnect the idle up diaphragm link.

(b) Remove the idle up diaphragm.

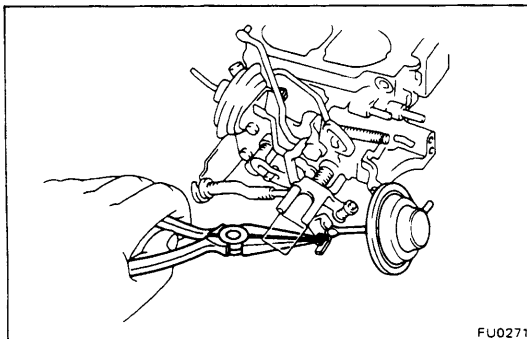

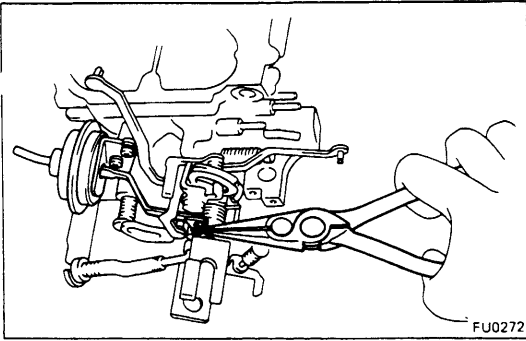
**7. REMOVE CHOKE OPENER**

- (a) Disconnect the choke opener link.
- (b) Remove the choke opener.

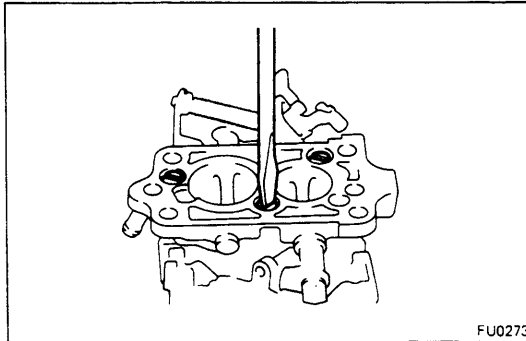
**8. SEPARATE BODY AND FLANGE**

- (a) Remove the three screws.
- (b) Separate the body and flange.

GENERAL CLEANING PROCEDURE

CLEAN DISASSEMBLED PARTS BEFORE INSPECTION

- (a) Wash and clean the cast parts with a soft brush and carburetor cleaner.
- (b) Clean off the carbon around the throttle valve.
- (c) Wash the other parts thoroughly in carburetor cleaner.
- (d) Blow all dirt and other foreign matter from the jets, fuel passages and restrictions in the body.

INSPECTION OF CARBURETOR

1. INSPECT FLOAT AND NEEDLE VALVE

- (a) Inspect the pivot pin (1) for scratches and excessive wear.
- (b) Inspect the float (2) for broken lip or wear in the pivot pin holes.
- (c) Inspect the spring (3) for breaks or deformation.
- (d) Inspect the needle valve (4) and plunger (5) for wear or damage.
- (e) Inspect the strainer (6) for rust or breaks.

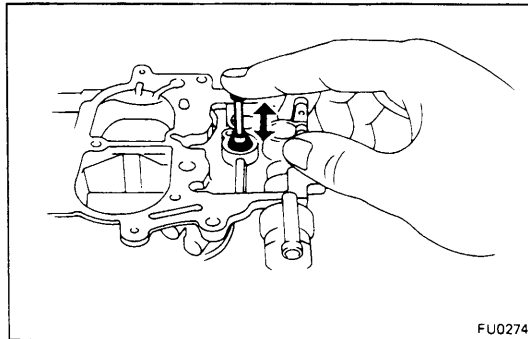
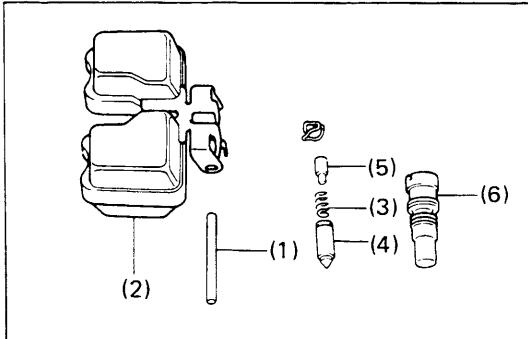

2. INSPECT POWER PISTON

Make sure that power piston moves smoothly.

3. INSPECT POWER VALVE

Check for faulty opening and closing action.

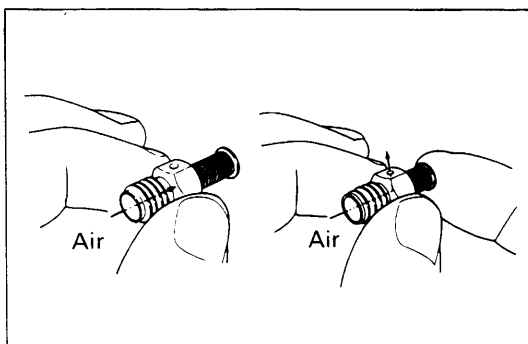

4. INSPECT FUEL CUT SOLENOID VALVE

- (a) Connect the terminals to the battery terminals.
 - (b) You should feel a click from the solenoid valve when the battery power is connected and disconnected.
- If the solenoid valve is not operating properly, replace it.
- (c) Replace the O-ring.

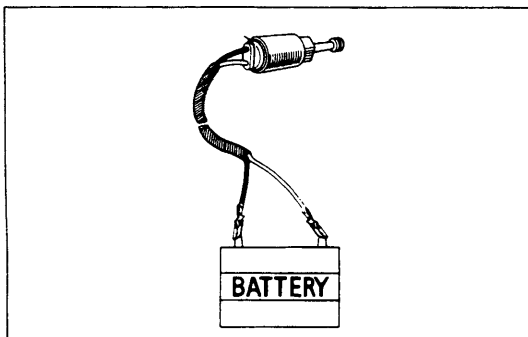

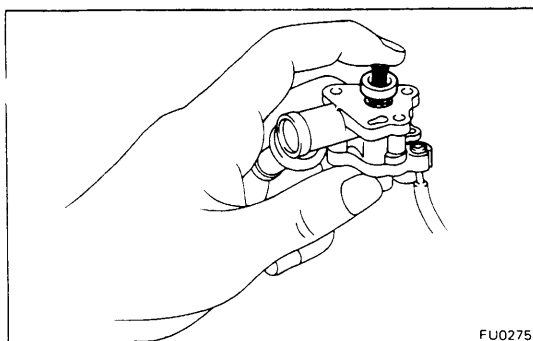

FU0275

5. INSPECT OUTER VENT CONTROL VALVE

- (a) Check the valve and valve seats for damage.
- (b) Check that the valve rod moves smoothly.

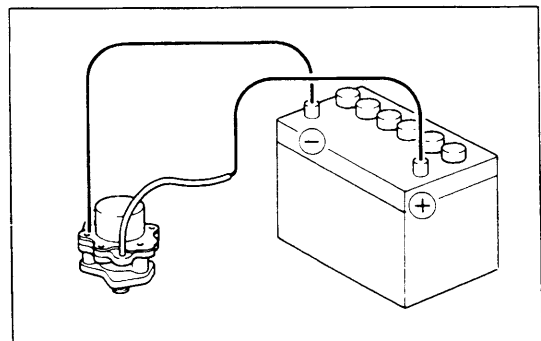

- (c) Connect the terminal to the battery terminal.
- (d) You should feel a click from the control valve when battery power is connected and disconnected.

If the control valve is not operating properly, replace it.

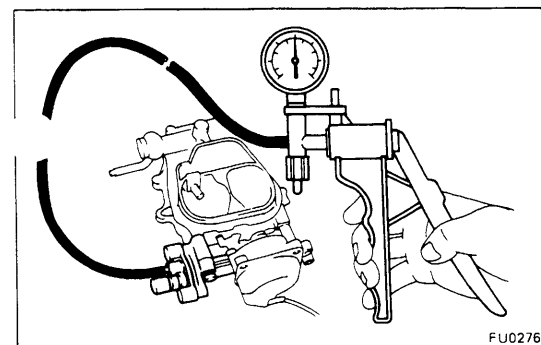

FU0276

6. INSPECT CHOKE BREAKER DIAPHRAGM

- (a) Apply vacuum to the diaphragm.
- (b) Check that the vacuum does not drop immediately.
- (c) Check that the choke valve opens slightly when vacuum is applied.

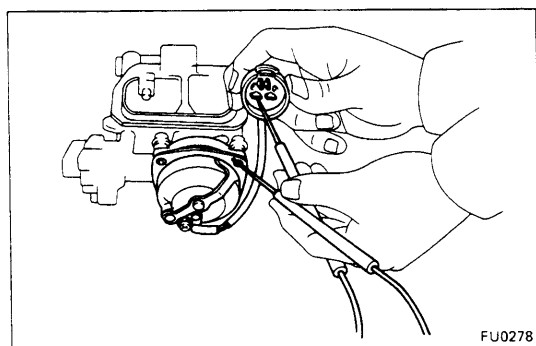

FU0278

7. INSPECT CHOKE HEATER

Using an ohmmeter, measure the resistance, between the terminal and heater housing.

Resistance: 20 – 22Ω at 20°C (68°F)

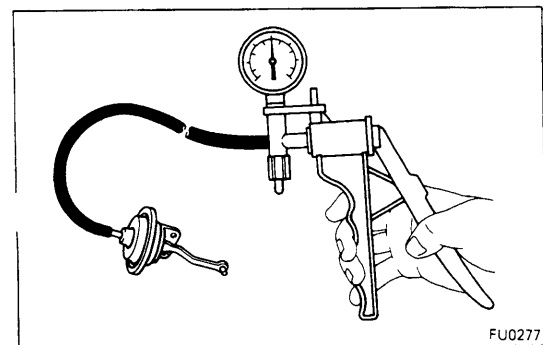

FU0277

8. INSPECT CHOKE OPENER DIAPHRAGM

- (a) Apply vacuum to the diaphragm.
- (b) Check that the vacuum does not drop immediately.
- (c) Check that the link moves when vacuum is applied.

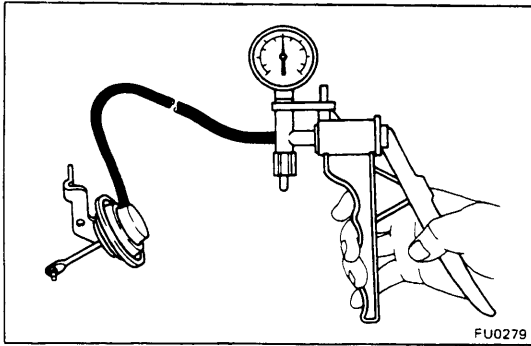
**9. INSPECT IDLE-UP DIAPHRAGM**

- (a) Apply vacuum to the diaphragm.
- (b) Check that the vacuum does not drop immediately.
- (c) Check that the link moves when vacuum is applied.

ASSEMBLY OF CARBURETOR

NOTE: Use new gaskets and O-rings throughout.

Assembly of Carburetor Body

(See page FU-4)

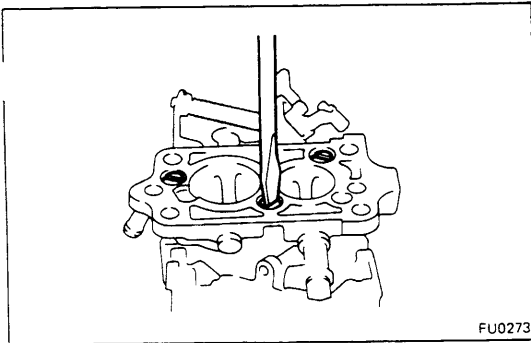

1. ASSEMBLE CARBURETOR BODY AND FLANGE

- (a) Place a new gasket and flange in position on the body.
- (b) Install the three screws.

2. INSTALL AUXILIARY ACCELERATION PUMP IN ORDER, AS SHOWN:

- (a) Diaphragm (with outer gasket)
- (b) Spring
- (c) Cover
- (d) Screws

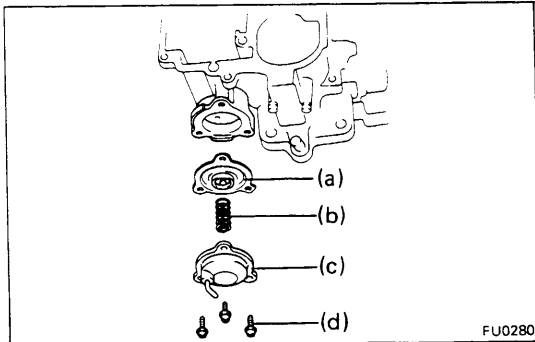

3. INSTALL ACCELERATION PUMP IN ORDER AS SHOWN:

- (a) Spring
- (b) Diaphragm (with outer gasket)
- (c) Cover
- (d) Boot
- (e) Screws

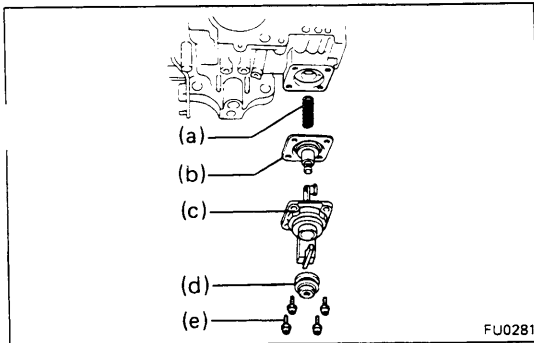

4. INSTALL CHOKE OPENER

Install the choke opener, and connect the link.

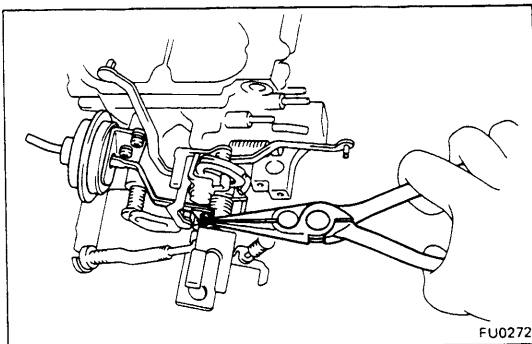

5. INSTALL IDLE-UP DIAPHRAGM

Install the idle-up diaphragm, and connect the link.

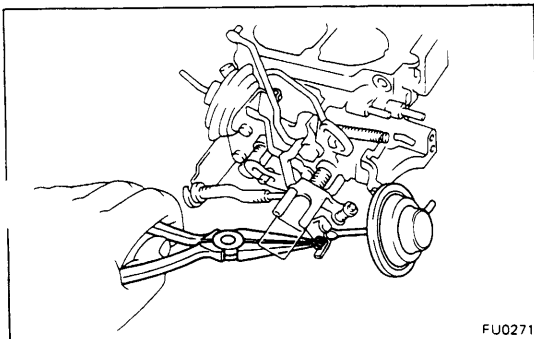

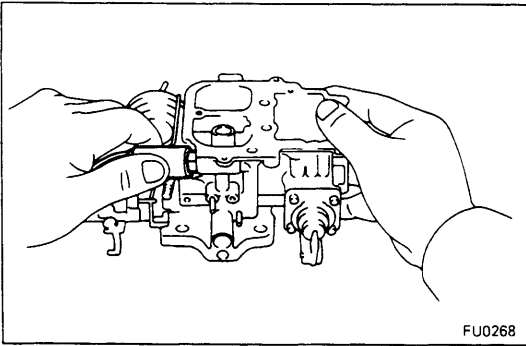

6. INSTALL FUEL CUT SOLENOID VALVE

Install the solenoid valve with a new gasket into the carburetor body.

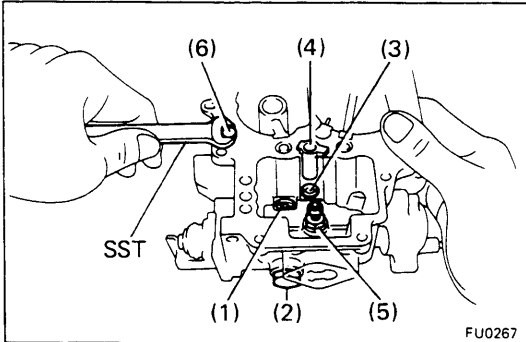

7. INSTALL MAIN JETS, SLOW JET AND POWER VALVE

- (a) Install the primary main jet (1) over a new gasket.
- (b) Install the plug (2) over a new gasket.
- (c) Install the secondary main jet (3) and metering needle guide (4).
- (d) Install the power valve (5).
- (e) Assemble a new O-ring on the slow jet.
- (f) Using SST, install the slow jet (6).

SST 09922-00010

8. INSTALL DASH POT WITH BRACKET (FOR A/T)

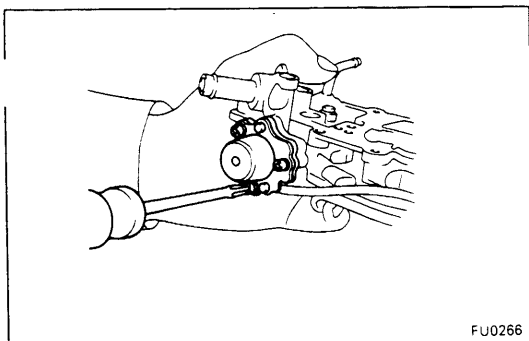

Assembly of Air Horn

(See page FU-4)

1. INSTALL OUTER VENT CONTROL VALVE

- (a) Place a new gasket in position on the air horn.
- (b) Install the outer vent control valve on the air horn with the three screws.

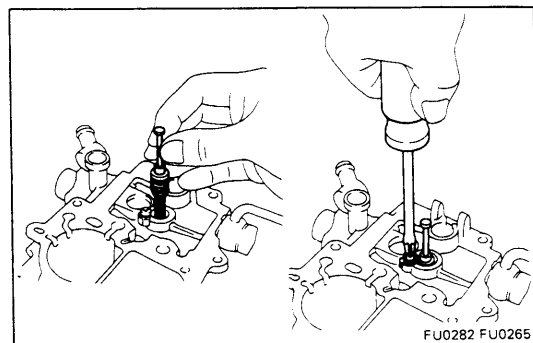

2. INSTALL POWER PISTON

- (a) Place the power piston spring and piston into the bore.
- (b) While pushing the piston, rotate the retainer over the piston.
- (c) Tighten the retainer screw.

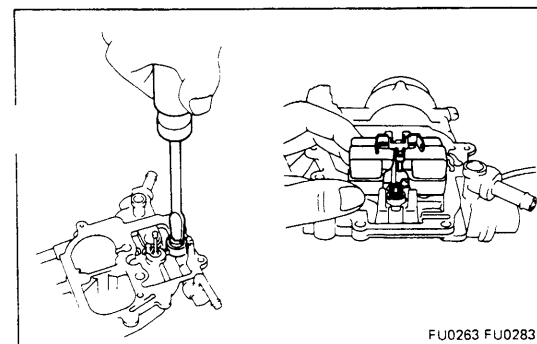

3. INSTALL FLOAT AND NEEDLE VALVE

- (a) Install the valve seat over a new gasket into the fuel inlet.
- (b) Install the needle valve onto the valve seat.
- (c) Insert the lip of the float under the wire of the needle valve.
- (d) Install the float and secure it with the pivot pin.

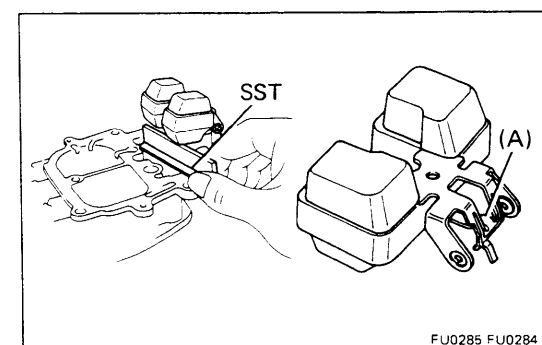

4. ADJUST FLOAT LEVEL

- (a) Allow the float to hang down by its own weight. Using SST, check the clearance between the float top and air horn.

SST 09240-00014

NOTE: This measurement should be made without a gasket on the air horn.

Float level (raised position): 9.8 mm (0.386 in.)

- (b) Adjust by bending portion (A) of the float.

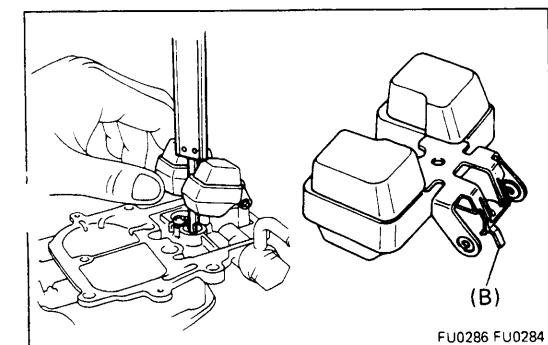

- (c) Lift up the float and, using vernier calipers, check the distance between the air horn and the float bottom.

Float level (lowered position): 48 mm (1.89 in.)

- (d) Adjust by bending portion (B) of the float.

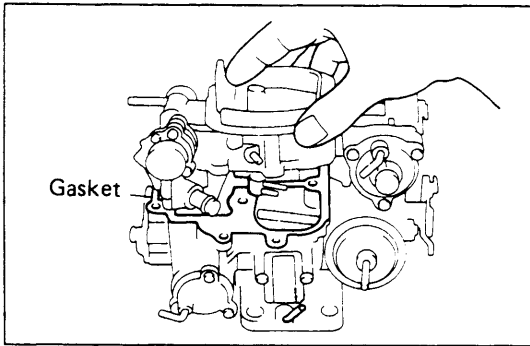

5. ASSEMBLE AIR HORN AND BODY

- (a) Put a new gasket on the body.
- (b) Carefully assemble the air horn and body.

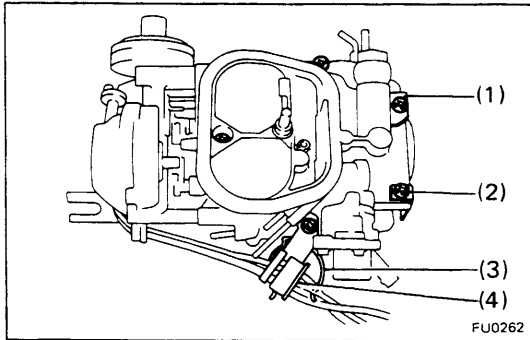

6. INSTALL FIVE SCREWS WITH OTHER PARTS AS FOLLOWS:

- (a) Install the fuel inlet bracket (1).
- (b) Install the number plate (2).
- (c) Install the VCV clamp (3) and wire clamp (4).
- (d) Connect the fast idle link.

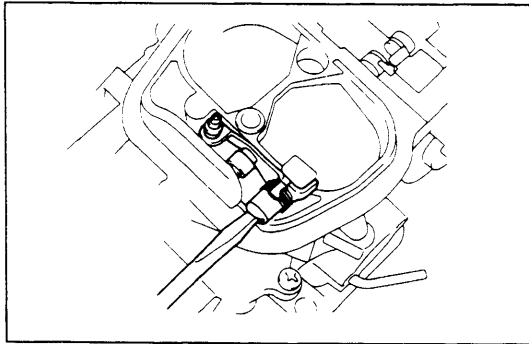

7. INSTALL METERING NEEDLE

- (a) Install the metering needle with a collar.
- (b) Hook the spring end into the hole.
- (c) Insert a washer and tighten the screw.

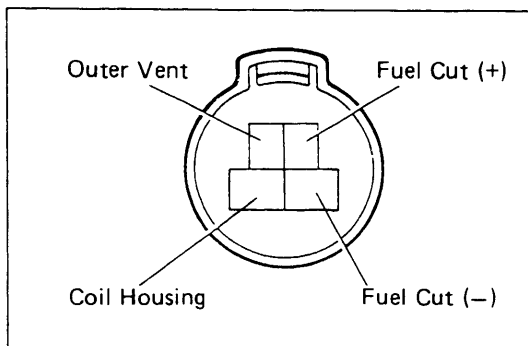

8. INSTALL TERMINAL TO CONNECTOR

- (a) Push in the terminal until it is securely locked in the connector lug.
- (b) Pull on the wire to confirm that it is securely locked.

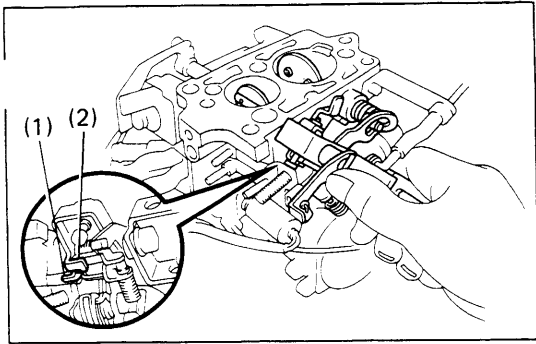

ADJUSTMENT OF CARBURETOR

NOTE: Use SST 09240-00014 to make adjustment.

1. CHECK AND ADJUST THROTTLE VALVE OPENING

Check the full opening angle of the primary and secondary throttle valves.

Adjust by bending the respective first throttle arm levers for the primary (1) and secondary (2).

Standard angle:

Primary — 90° from horizontal plane

Secondary — 90° from horizontal plane

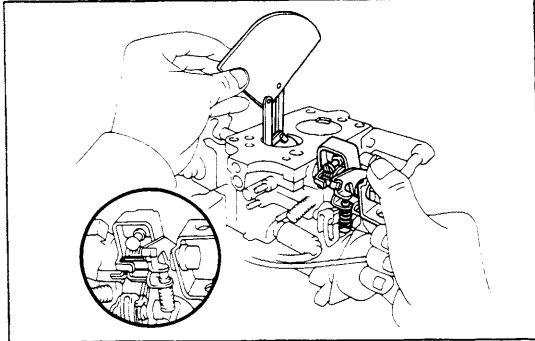

2. CHECK SECONDARY TOUCH ANGLE

Check the primary throttle valve opening at the same time the second throttle valve just starts to open.

Standard angle: 59° from horizontal plane

NOTE: It is not necessary to adjust the secondary touch angle.

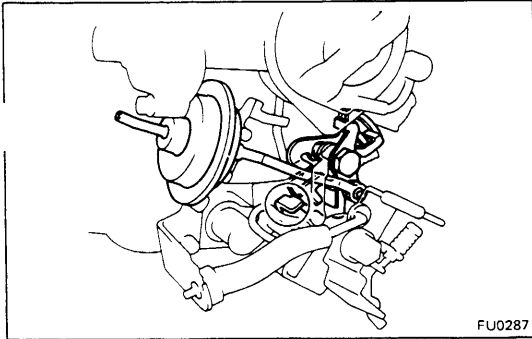

3. CHECK AND ADJUST FAST IDLE SETTING

- (a) Set the throttle shaft lever to the first step of the fast idle cam as shown.

- (b) With the choke valve fully closed, check the primary throttle valve angle.

Adjust by turning the fast idle adjusting screw.

Standard angle: 23° from horizontal plane

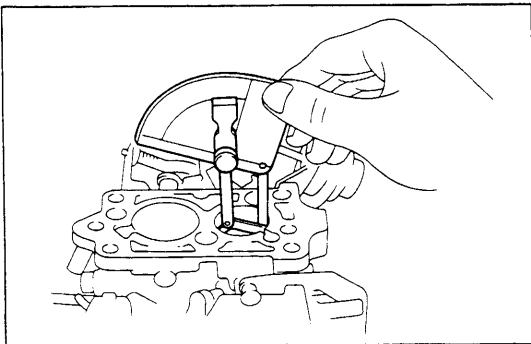

4. CHECK AND ADJUST UNLOADER

With the primary throttle valve fully opened, check the choke valve angle. Adjust by bending the primary throttle arm.

Standard angle: 45° from horizontal plane

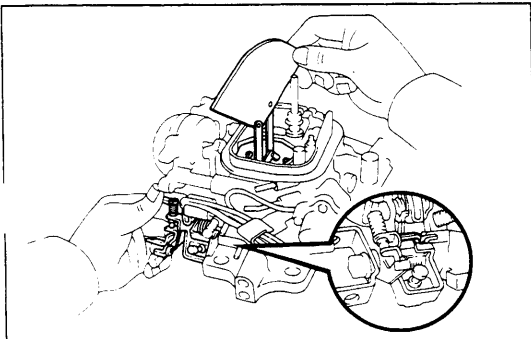

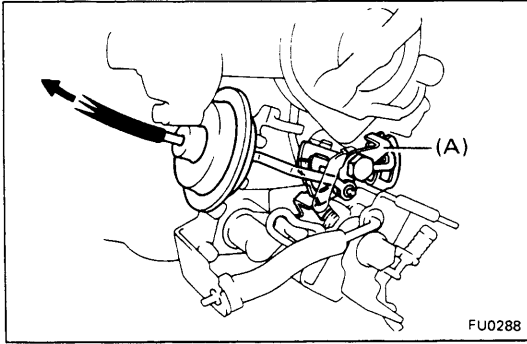

5. CHECK AND ADJUST CHOKE OPENER

- (a) Apply vacuum to the choke opener diaphragm.
- (b) Check that the fast idle cam is released to the fourth step. Adjust by bending choke opener lever A.
- (c) Disconnect the vacuum hose.
- (d) Close the choke valve and set the fast idle lever to the first step.
- (e) Check that there is clearance between the choke opener lever and fast idle cam.

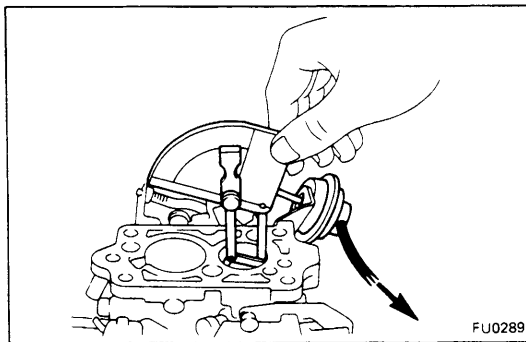
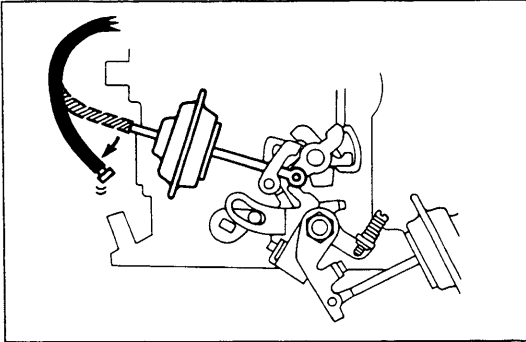

6. CHECK AND ADJUST IDLE-UP

- (a) Apply vacuum to the idle-up diaphragm.
- (b) Check the throttle valve opening angle. Adjust by turning the adjusting screw.

Standard angle: 16.5° from horizontal plane

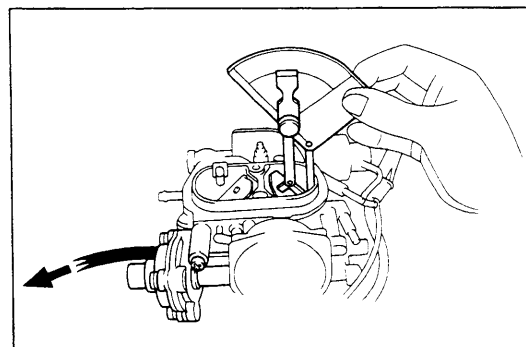

7. CHECK CHOKE BREAKER

- (a) Apply vacuum to the choke breaker diaphragm.
- (b) Close the choke valve by hand.
- (c) Check the choke valve opening angle.

Standard angle: 42° from horizontal plane

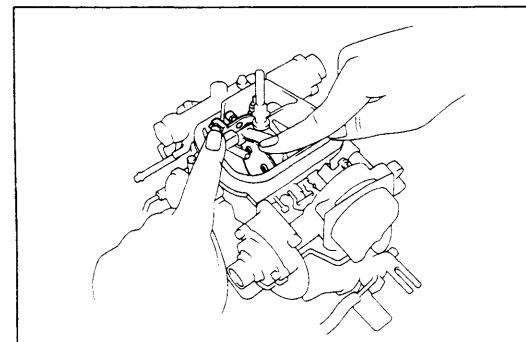

8. CHECK AIR VALVE AND METERING NEEDLE

- (a) Check that the air valve and metering needle move smoothly together.
- (b) While the primary throttle valve angle is idle position, check the air valve opening angle.
- (c) While the primary throttle valve is full opening angle, check that there is clearance between the connecting rod and stopper.

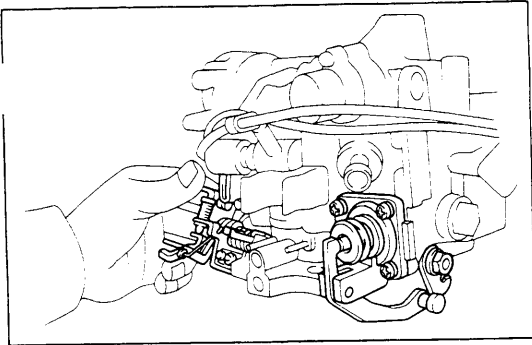

9. CHECK ACCELERATION PUMP

Rotate the throttle shaft and check that the pump lever and diaphragm rod move smoothly.

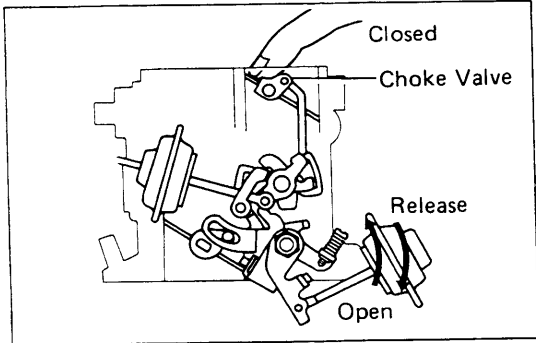

10. INSPECT AND ADJUST SECONDARY THROTTLE VALVE LOCK SYSTEM

(a) While holding the throttle slightly open, push the choke valve closed, and hold it closed as you release the throttle valve.

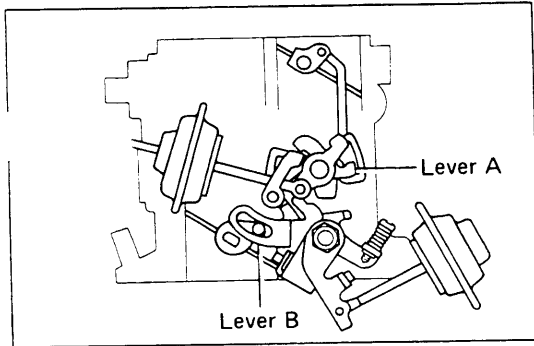

(b) In condition (a), check that lever A is holding lever B locked as shown.

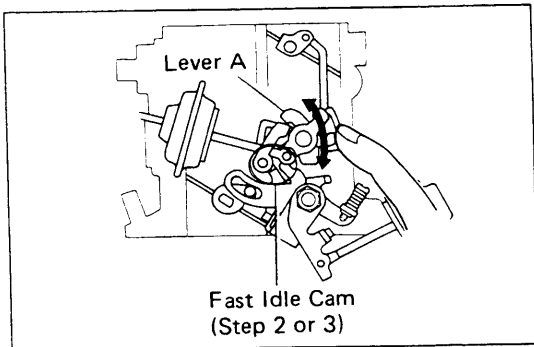

(c) Check that the lever A moves smoothly at step 2 or 3 of the fast idle cam. Adjust by bending the top of lever A.

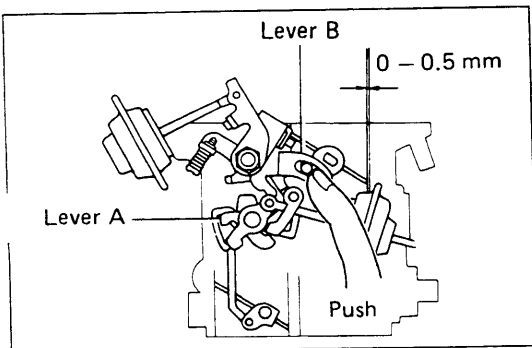

(d) In condition (a), rotate lever B to where it makes contact with lever A. In this position, measure the clearance between the secondary valve and bore. Adjust by bending the top of lever A.

**Standard clearance: 0 — 0.5 mm
(0 — 0.020 in.)**

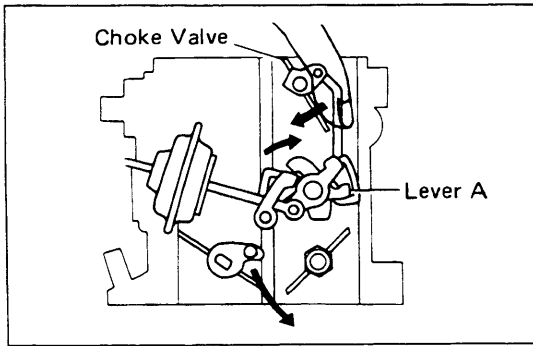

- (e) With the choke valve opened (above 52°), check that lever A unlocks when the throttle valve is opened.

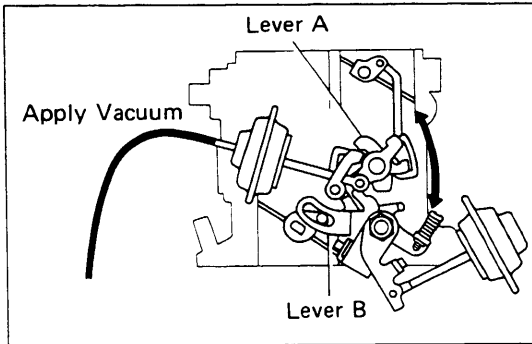

- (f) Repeat step (a).
 (g) Apply vacuum to the choke opener and check that lever A withdraws and that lever B unlocks.

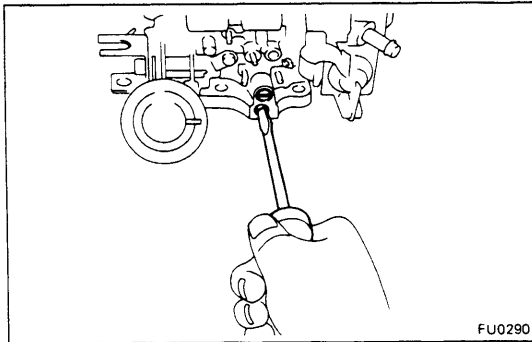

FU0290

11. PRESET IDLE MIXTURE ADJUSTING SCREW

If the idle mixture adjusting screw plug has been removed, fully screw in the idle mixture screw and then unscrew it to the following amount.

Standard: Return $3\frac{1}{2}$ turns from fully closed position

CAUTION: Use care not to screw it in too tightly and damage the screw tip.

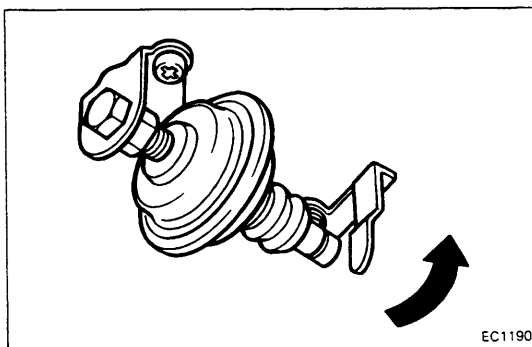

EC1190

12. CHECK AND ADJUST DASH POT

- (a) Open the throttle valve until the throttle lever separates from the dash pot end.

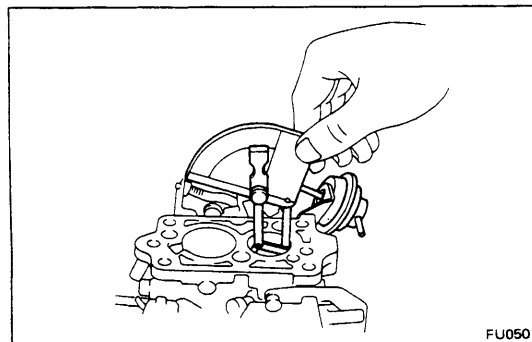

FU0501

- (b) Release the throttle valve gradually, and check the dash pot touch angle when the throttle lever touches the dash pot end.

Standard angle: 24.5° from horizontal plane

If the dash pot touch angle is not as specified, unlock the lock nut, and adjust the dash pot touch angle by turning the dash pot diaphragm.

INSTALLATION OF CARBURETOR

1. INSTALL CARBURETOR

- (a) Place the insulator on the intake manifold.
- (b) Install the carburetor. Tighten the bolts and nuts securely.

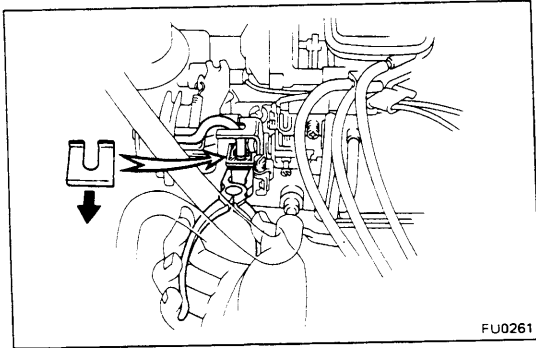

2. CONNECT ACCELERATOR LINKAGE

Connect the linkage and install the clip.

3. CONNECT THROTTLE CABLE FOR AUTOMATIC TRANSMISSION (See page AT-20)

4. CONNECT FOLLOWING HOSES TO CARBURETOR:

- (a) Fuel inlet hose
- (b) PCV hose
- (c) Emission control hoses (see system layout in the emission control section or the layout printed under the hood)
- (d) Wiring connector

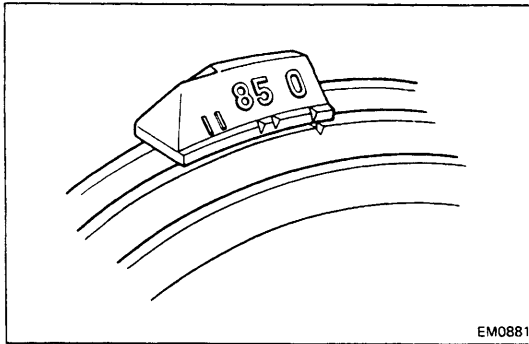

EM0881

ADJUSTMENT OF CARBURETOR (ON-VEHICLE)

1. INITIAL CONDITIONS OF CARBURETOR ADJUSTMENT

- (a) All accessories switched off
- (b) Ignition timing set correctly
- (c) Transmission in N range

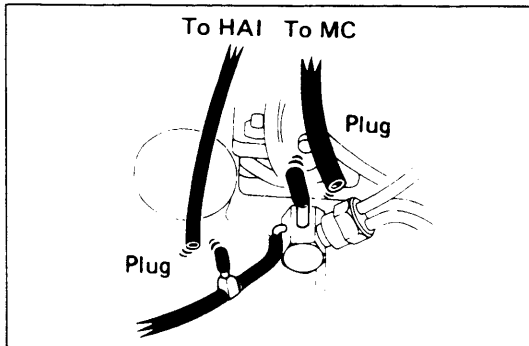

2. START ENGINE

Start the engine and warm it up to normal operating temperature.

NOTE: Plug the hose connections for HAI and MC (for M/T) systems to prevent rough idling.

3. CHECK FLOAT LEVEL

Fuel level should be about even with the correct level in the sight glass.

4. CHECK THAT CHOKE VALVE OPENS FULLY

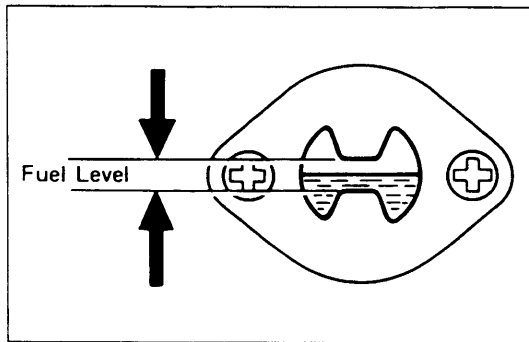

5. CONNECT TACHOMETER

Connect the tachometer test probe to the ignition coil negative terminal.

CAUTION:

1. NEVER allow the ignition coil terminals to touch ground as it could result in damage to the igniter and/or ignition coil.
2. As some tachometers are not compatible with this ignition system, it is recommended that you consult with the manufacturer.

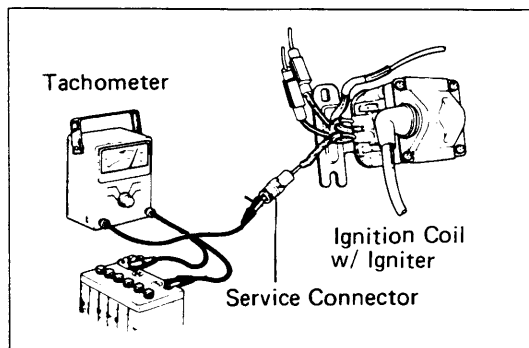

6. ADJUST FAST IDLE SPEED

- (a) Disconnect the vacuum hose from the choke opener diaphragm and EGR valve, and plug the hose end.

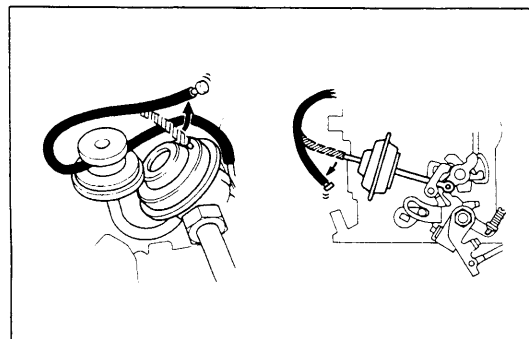

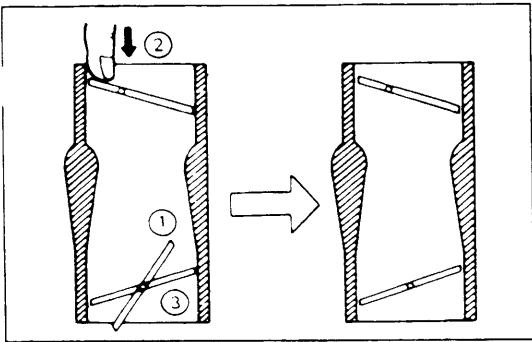

- (b) Set the fast idle cam.
While holding the throttle valve slightly open, push the choke valve closed and hold it closed as you release the throttle valve.
- (c) Start the engine, but do NOT depress the accelerator pedal.

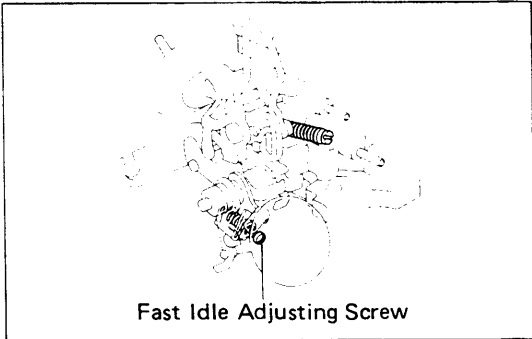

- (d) Adjust the fast idle speed by turning the fast idle adjusting screw.

Fast idle speed: 2,600rpm

- (e) Reconnect the vacuum hoses to the proper locations.

7. CHECK DASH POT SETTING SPEED

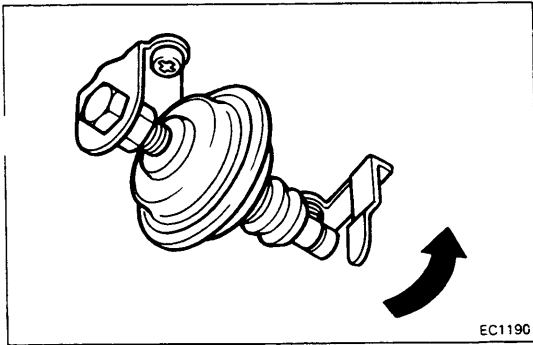

- (a) Open the throttle valve until the throttle lever separates from the dash pot end.

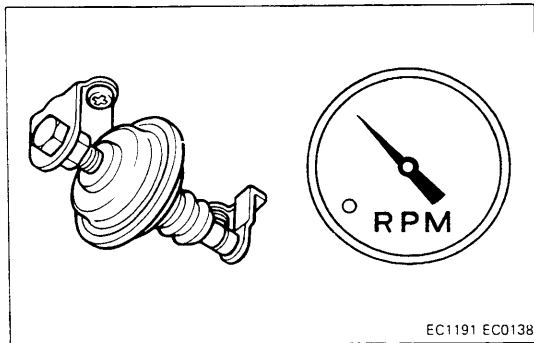

- (b) Release the throttle valve gradually, and check the dash pot setting speed when the throttle lever touches the dash pot end.

Dash pot setting speed: 3,000 rpm

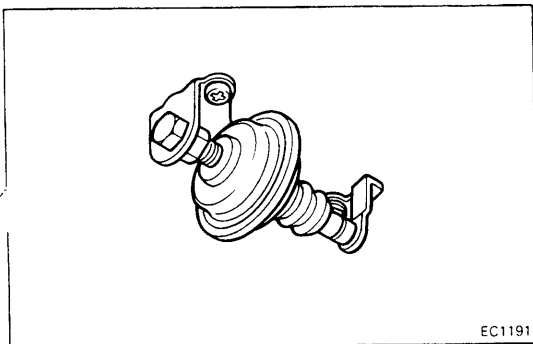

If the speed is not as specified, unlock the lock nut, and adjust the setting speed by turning the dash pot diaphragm.

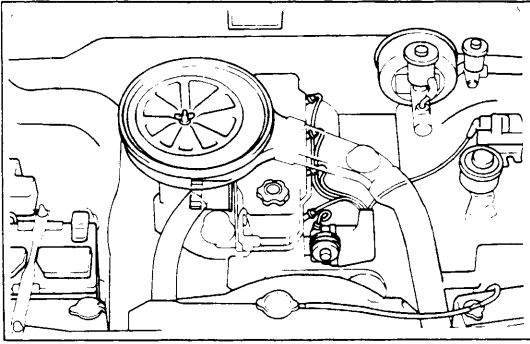
**8. STOP ENGINE****9. INSTALL AIR CLEANER**

- (a) Place the air cleaner in position and install the two mounting nuts and butterfly nut.
- (b) Connect the air intake hoses.
- (c) Connect the emission control hoses.

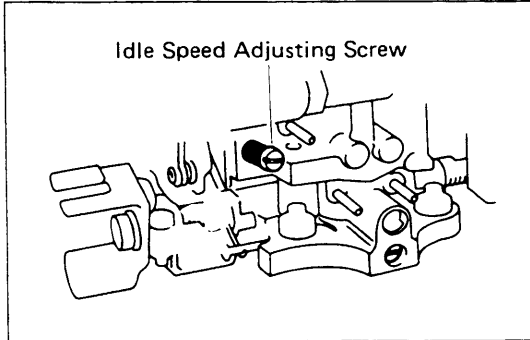
**10. ADJUST IDLE SPEED**

Adjust the idle speed by turning the idle speed adjusting screw.

Idle speed: 700 rpm M/T
750 rpm A/T

11. IF NECESSARY, ADJUST IDLE MIXTURE
(See page FU-25)**12. REMOVE TACHOMETER**

Idle Mixture

ADJUSTMENT OF IDLE MIXTURE

NOTE:

- To conform with regulations, the idle mixture adjusting screw is adjusted and plugged with a steel plug by the manufacturer.
Normally, this steel plug should not be removed.
- When troubleshooting rough idle, check all other possible causes before attempting to adjust the idle mixture. (See TROUBLESHOOTING on page FU-2)
Only if no other factors are found to be at fault, should the idle mixture be adjusted and, when doing so, remove the plug and follow the procedure described below.

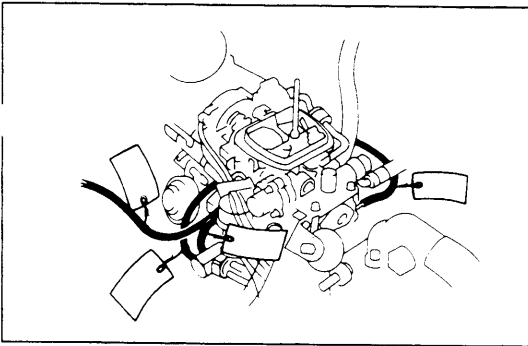

1. REMOVE CARBURETOR

- Before disconnecting the vacuum hoses, use tags to identify how they should be reconnected.
- Remove the carburetor from the engine.
- After removing the carburetor, cover the intake manifold with a clean rag.

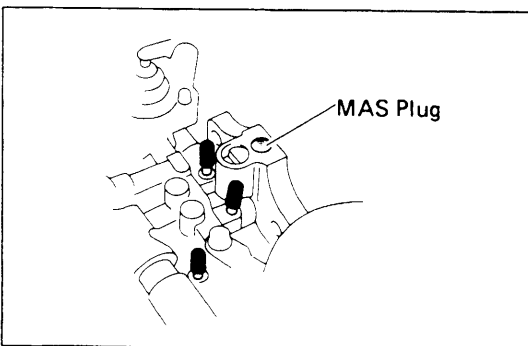

2. REMOVE MIXTURE ADJUSTING SCREW PLUG (MAS PLUG)

- Plug each carburetor vacuum port to prevent entry of steel particles when drilling.
- Mark the center of the plug with a punch.

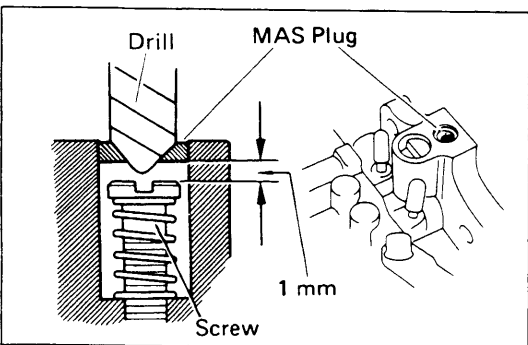

- Drill a 6.5mm ϕ (0.256 in. ϕ) hole in the center of the plug.

NOTE:

- As there is only 1 mm (0.04 in.) clearance between the plug and screw, drill carefully and slowly to avoid drilling onto the screw.
- The drill may force the plug off at this time.

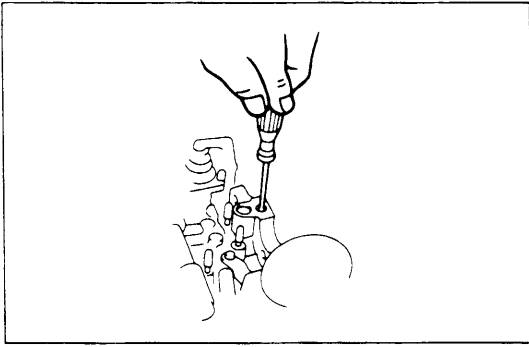

- (d) Through the hole in the plug, fully screw in the mixture adjusting screw with a screwdriver.

NOTE: Be careful not to damage the screw tip by tightening the screw too tight.

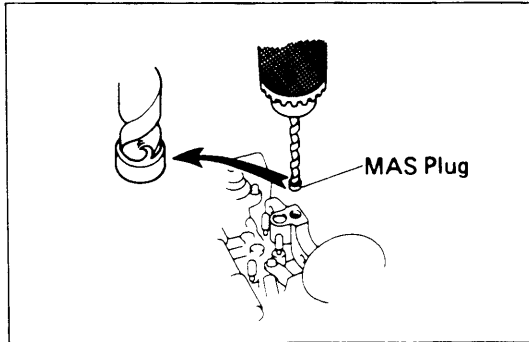

- (e) Use a 7.5mm ϕ (0.295 in. ϕ) drill to force the plug off.

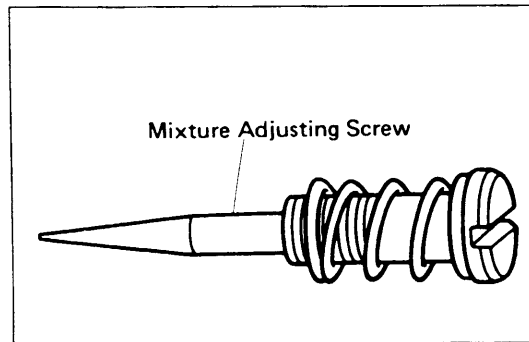

3. INSPECT MIXTURE ADJUSTING SCREW

- (a) Blow off any steel particles with compressed air.
 (b) Remove the screw and inspect it.

If the drill has gnawed into the screw top or if the tapered position is damaged, replace the screw.

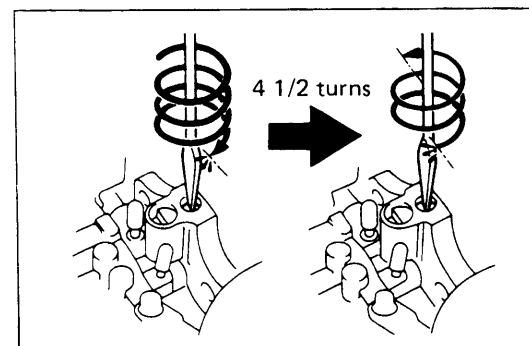

4. REINSTALL MIXTURE ADJUSTING SCREW

Fully screw in the idle mixture adjusting screw and then unscrew it about 3 $\frac{1}{2}$ turns.

NOTE: Be careful not to damage the screw tip by tightening the screw too tight.

5. REINSTALL CARBURETOR

- (a) Reinstall the carburetor on the engine.
 (b) Reconnect the vacuum hoses to the proper locations. Refer to the information label on the vacuum hose.

6. REINSTALL AIR CLEANER

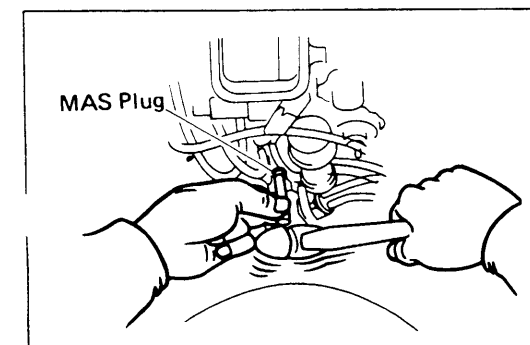
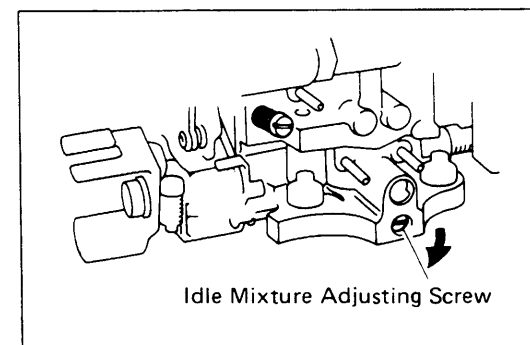
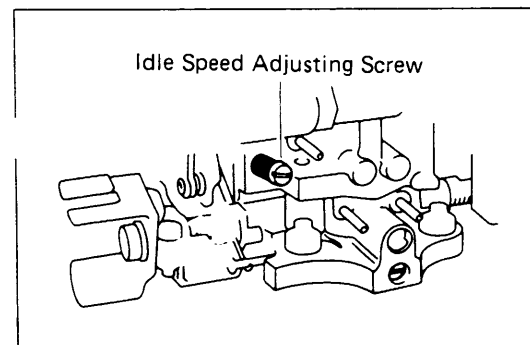
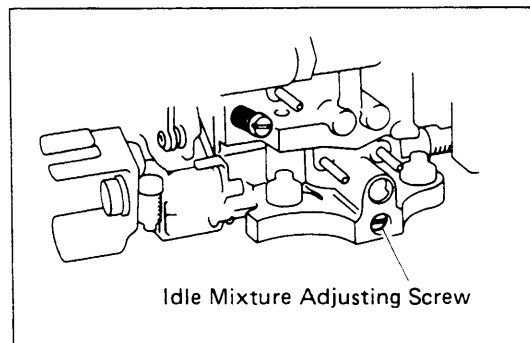
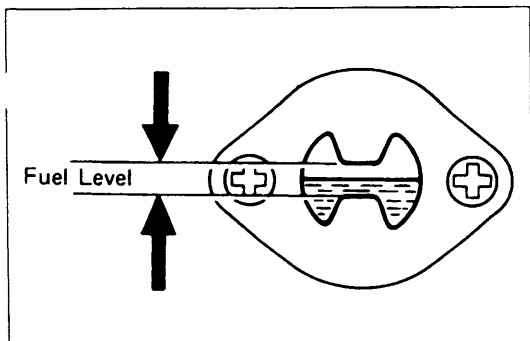

7. ADJUST IDLE SPEED AND IDLE MIXTURE

- (a) Initial conditions:
 - Air cleaner installed
 - Normal operating coolant temperature
 - Choke fully open
 - All accessories switched off
 - All vacuum lines connected
 - Ignition timing set correctly
 - Transmission in N range
 - Fuel level should be about even with the correct level in the sight glass.
 - EBCV off (for Calif.)
- (b) Start the engine.
- (c) Set to the maximum speed by turning the IDLE MIXTURE ADJUSTING SCREW.

- (d) Set to the idle mixture speed by turning the IDLE SPEED ADJUSTING SCREW.

Idle mixture speed:

740 rpm (M/T)
790 rpm (A/T)

- (e) Before moving to the next step, continue adjustments (c) and (d) until the maximum speed will not rise any further no matter how much the IDLE MIXTURE ADJUSTING SCREW is adjusted.

- (f) Set to the idle speed by screwing in the IDLE MIXTURE ADJUSTING SCREW.

Idle speed:

700 rpm (M/T)
750 rpm (A/T)

NOTE: This is the Lean Drop Method for setting idle speed and mixture.

8. PLUG IDLE MIXTURE ADJUSTING SCREW

- (a) Remove the air cleaner.
- (b) Tap in new plug until it is even with carburetor surface.
- (c) Reinstall the air cleaner.

9. CHECK AND ADJUST FAST IDLE SPEED (See step 6 on page FU-22)

FUEL PUMP COMPONENTS

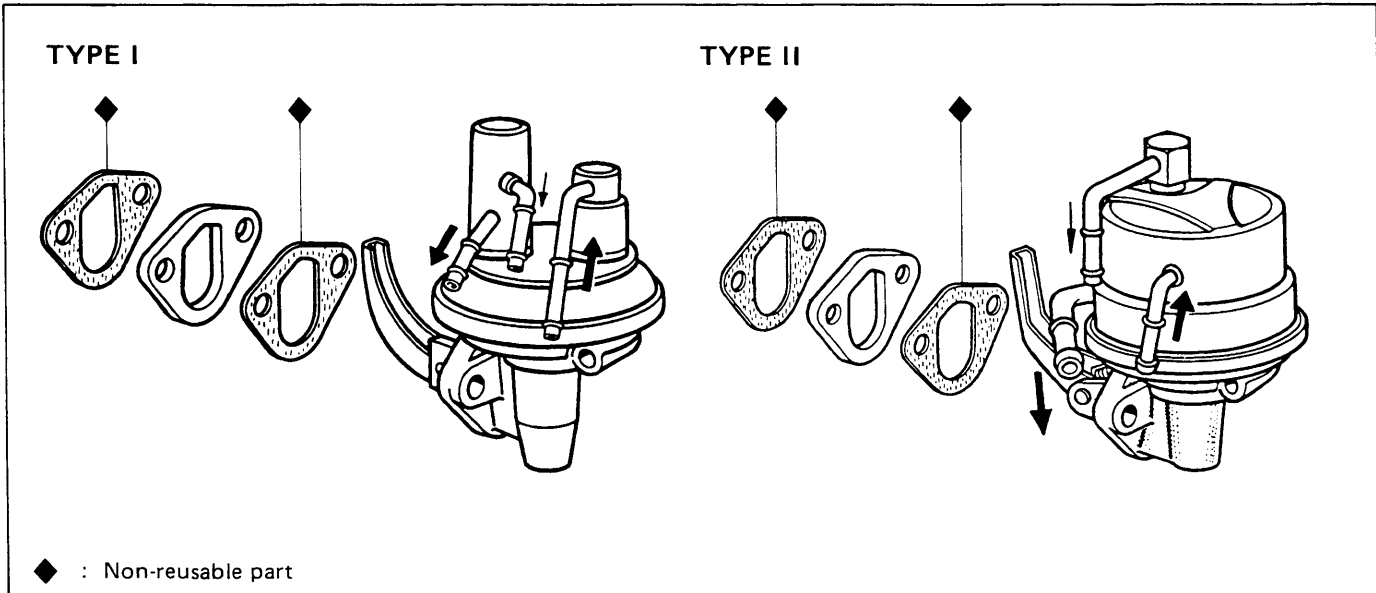

REMOVAL OF FUEL PUMP

1. DRAIN COOLANT

Open the radiator drain cock and allow the coolant to drain into a suitable container.

2. DISCONNECT UPPER RADIATOR HOSE

3. DISCONNECT THREE FUEL HOSES FROM FUEL PUMP

4. REMOVE FUEL PUMP

Remove the two bolts, fuel pump and gasket.

INSPECTION OF FUEL PUMP (Airtight Test)

PRECHECKS

Before performing the following checks on the fuel pump:

- Run some fuel through the pump to insure that the check valves seal tightly (a dry check valve may not seal properly).
- Without blocking off any pipe, operate the pump lever and check the amount of force necessary for operation and the amount of arm play. This same amount of force should be used in the checks.

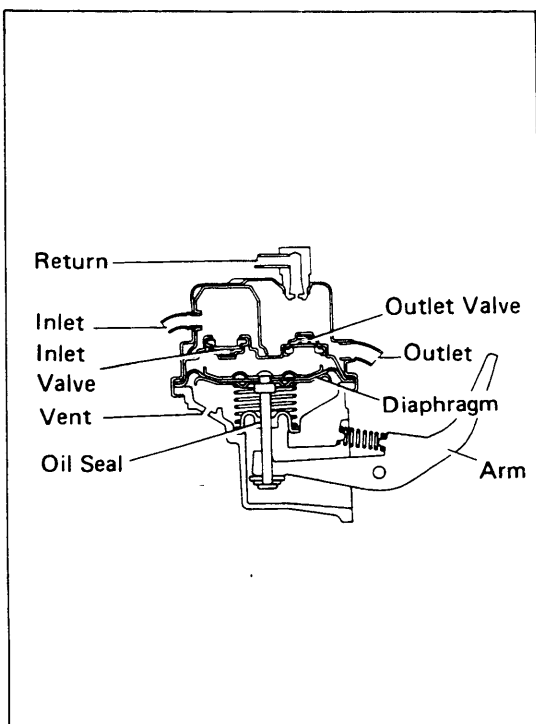

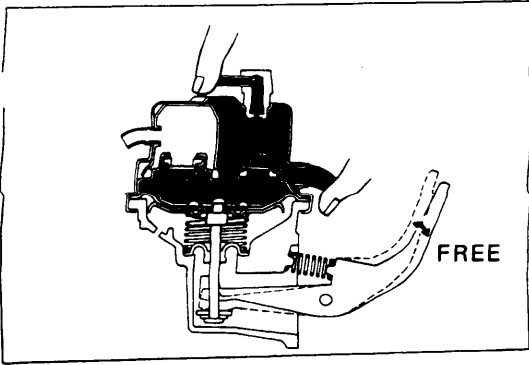

1. CHECK INLET VALVE

Block off the outlet pipes with your finger and check that there is an increase in lever arm play and that the lever arm moves without tension.

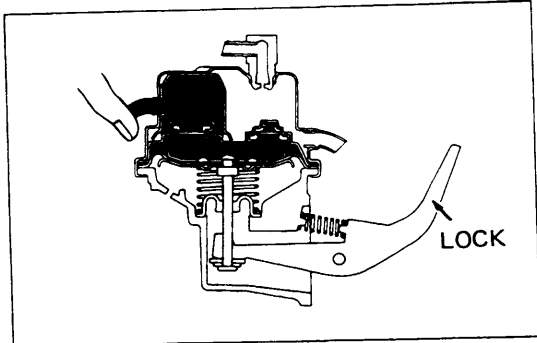

2. CHECK OUTLET VALVE

Block off the inlet pipe with your finger and check that the arm locks (does not operate with same amount of force used in the precheck above).

NOTE: Never use more force than that used in the precheck (This applies to checks 3 and 4 also).

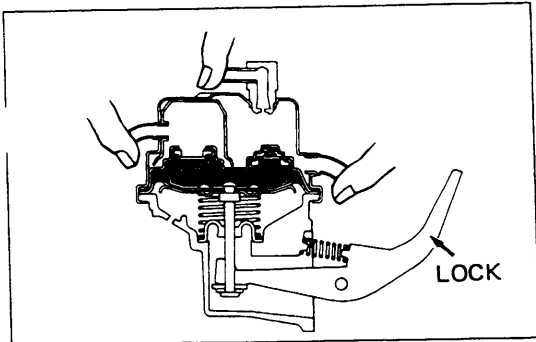

3. CHECK DIAPHRAGM

Block off the inlet and outlet pipes and check that the pump arm locks.

NOTE: If any of these checks are not as specified, the caulking (sealing) of the body and upper casing is defective.

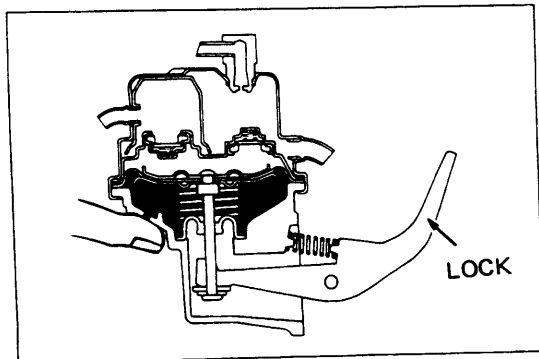

4. CHECK OIL SEAL

Block off the vent hole with your finger and check that the pump arm locks.

INSTALLATION OF FUEL PUMP

(See page FU-28)

1. INSTALL FUEL PUMP WITH NEW GASKET

2. INSTALL TWO BOLTS

3. CONNECT THREE FUEL HOSES TO FUEL PUMP

4. CONNECT UPPER RADIATOR HOSE

5. FILL WITH COOLANT

Close the radiator drain cock and fill the radiator with a good brand of ethylene-glycol coolant.

6. START ENGINE AND CHECK FOR LEAKS

Fuel Tank and Line

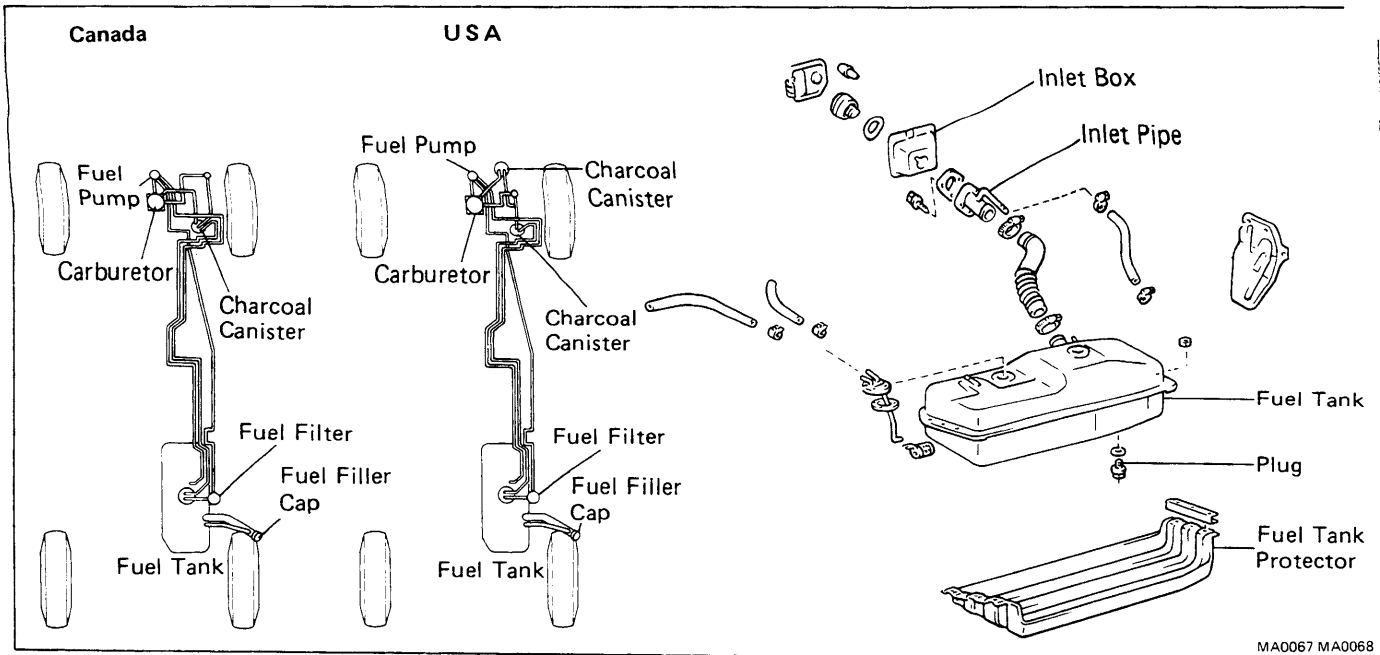

MA0067 MA0068

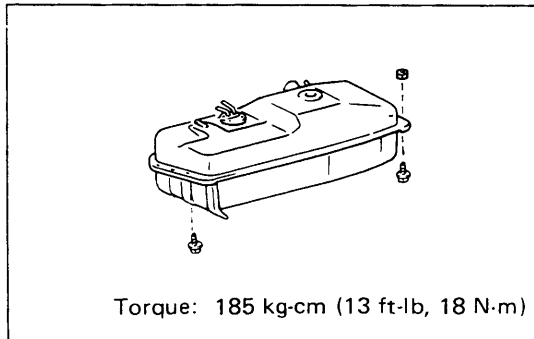

PRECAUTIONS

1. Always use new gaskets when replacing the fuel tank or component parts.
2. When re-installing, be sure to include the rubber protectors on the upper surfaces of the fuel tank and tank band.
3. Apply the proper torque to all tightening parts.

INSPECT FUEL LINES AND CONNECTIONS

- (a) Inspect the fuel lines for cracks, or leakage and connections for deformation.
- (b) Inspect the fuel tank vapor vent system hoses and connections for looseness, sharp bends or damage.
- (c) Inspect the fuel tank for deformation, cracks, fuel leakage or tank band looseness.
- (d) Inspect the inlet pipe for damage or fuel leakage.
- (e) The hose and tube connections are as shown in the illustration.

If a problem is found, repair or replace the parts as necessary.

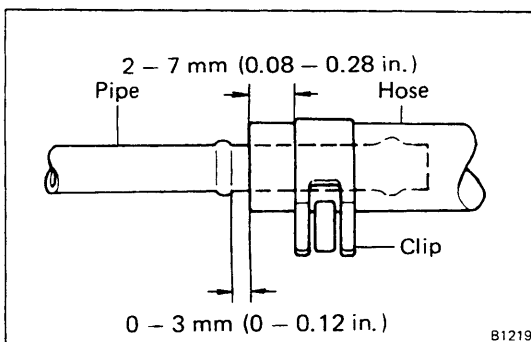

B1219