





05–210 Inspection and adjustment of valve clearance

Valve clearance	with engine cold (approx. 20 °C)	with engine warm (60 °C ± 15 °C)
Intake	0.10 ¹⁾	0.15 ¹⁾
Exhaust	0.35	0.40

1) 0.05 mm higher during lasting outside temperatures below –20 °C.

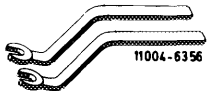
Tightening torque	Nm
Nuts for cylinder head cover	15

Special tools

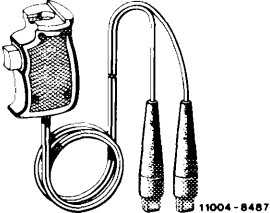
Valve adjusting wrench 14 mm (2 each)	 11004-6356	615 589 00 01 00
Holding wrench for valve spring retainer	 11004-7118	615 589 00 03 00
Slip gage holder, red	 11004-6364	617 589 00 40 00
Slip gage blades	0.10 mm thick	617 589 00 23 00
	0.15 mm thick	617 589 01 23 00
	0.20 mm thick	117 589 00 23 00
	0.35 mm thick	617 589 03 23 00
	0.40 mm thick	617 589 04 23 00
Socket 27 mm, 1/2" square for rotating engine	 11004-8193	001 589 65 09 00
Contact handle for rotating engine (component of compression pressure recorder 001 589 46 21 00)	 11004-8487	001 589 46 21 08

Note

Check valve clearance with engine cold or warm and adjust, if required.

During adjustment, check cap nut and counternut for tight seat and wear.

63 Cap nut
63a Counternut

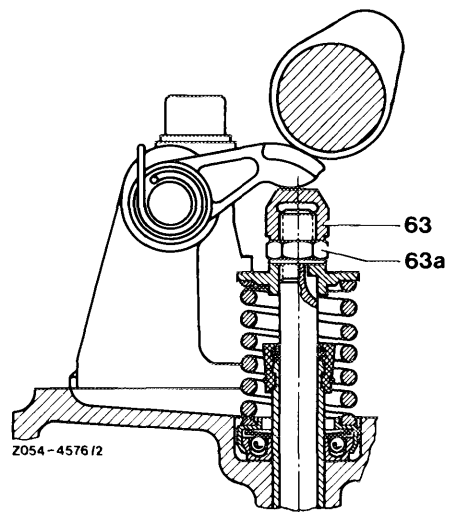

Also check valves which are not in need of adjustment.

Renew cap nuts and conternuts in the following cases:

Height of conternut (A) below 5 mm (H). New conternuts (B) have a height of 6 mm.

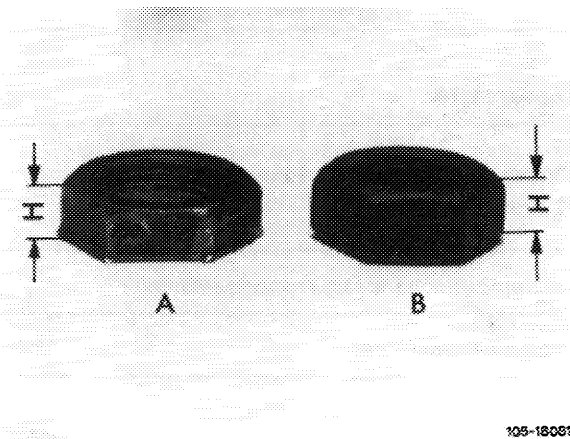

105-18081

Counterlocking surfaces of nuts badly worn (arrows).

In such cases, check threads on valve stem and also replace valves, if required.

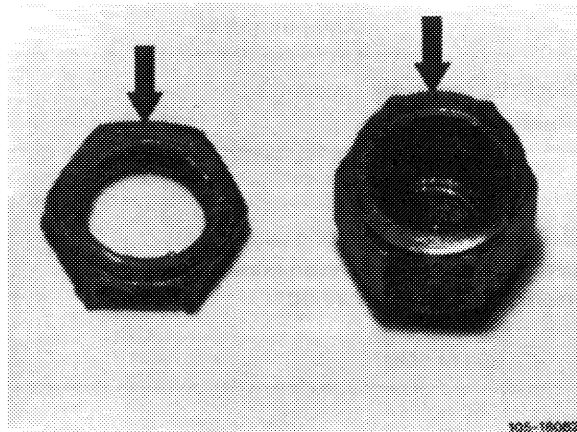

105-19082

Check camshafts made of malleable iron (code number 00) for wear. Formation of excessive flats on cam (arrow) may result in loosening of counterlocked nuts. If flats show up, renew camshaft, rocker arm, valve springs, as well as cap nuts and conternuts. Also check valves and replace, if required.

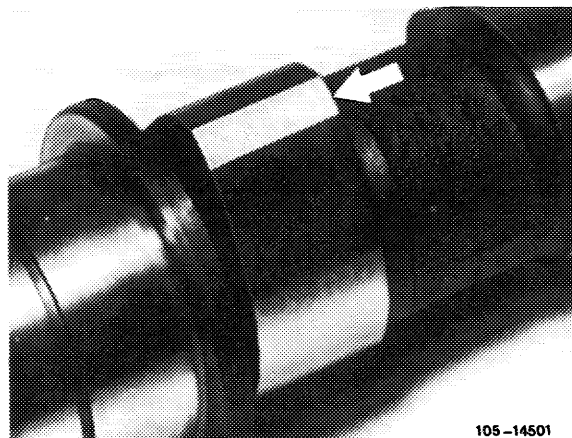

105-14501

On camshafts made of chilled cast iron (code number 05 and 08) a slight formation of flats is possible, but flats will not increase and are therefore technically insignificant.

Adjustment

1 Disconnect regulating linkage to remove cylinder head cover. Pull out locking eye of longitudinal regulating shaft (arrow).

Model 126.120

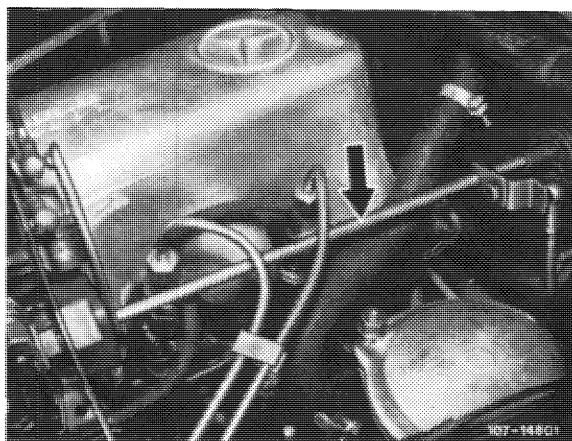

On models 116.120 and 123, pull longitudinal regulating shaft out of rubber mount in forward direction and remove in rearward direction.

Model 123

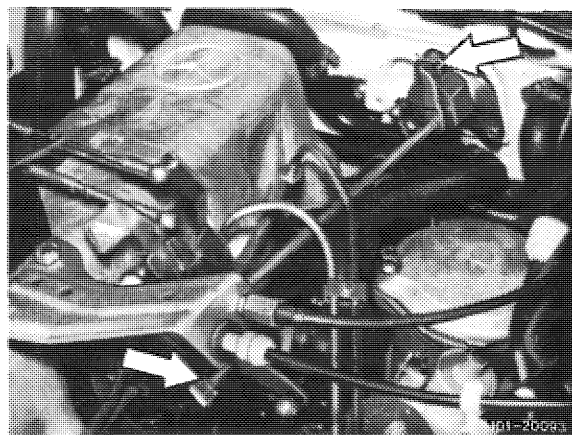

On models 123 with automatic transmission 722.303 (W 4 A 040) and 126.120, pull off central plug for vacuum lines (71) or vacuum lines. Disconnect Bowden wire, compress black plastic clip (arrow) and pull Bowden wire out of holder in rearward direction.

Model 126.120

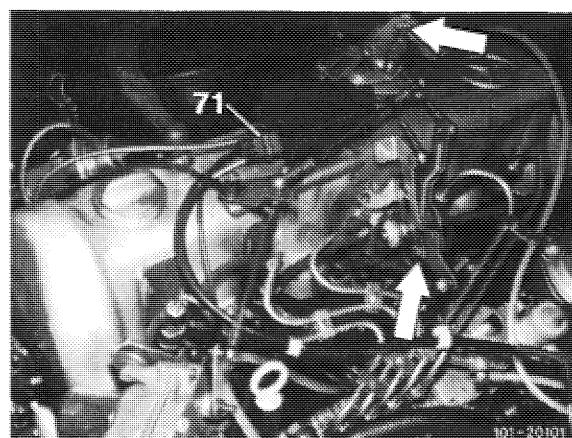

2 Check valve clearance between slide surface of rocker arm and cam base circle of camshaft (arrow). Tip of cam should be vertical in relation to rocker arm.

Valve clearance is correctly set when pulling of slip gage blade requires some effort.

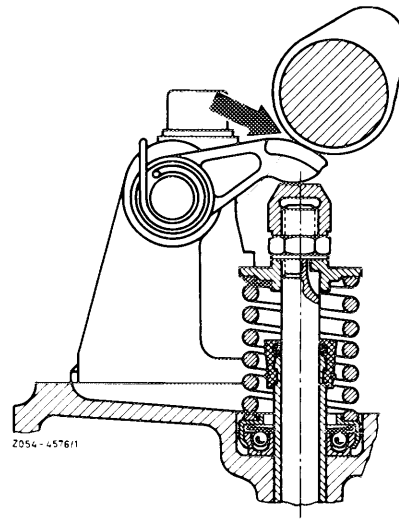

Observe layout of intake and exhaust valves.

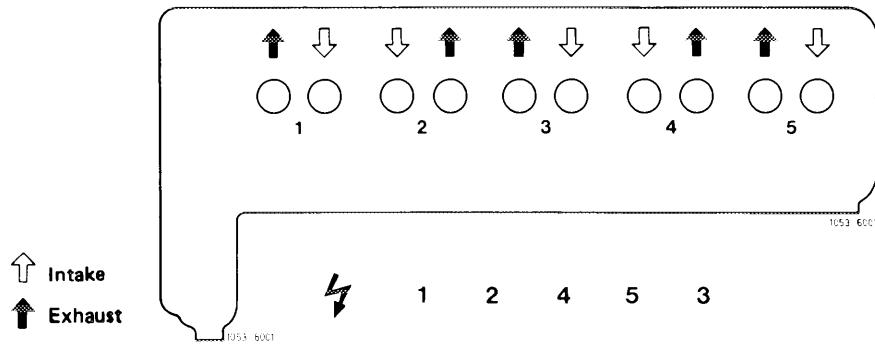

The engine can be rotated as follows:

a) With tool combination at crankshaft front

Attention!
Do not rotate engine at fastening bolt of camshaft sprocket.

Do not rotate crankshaft in reverse.

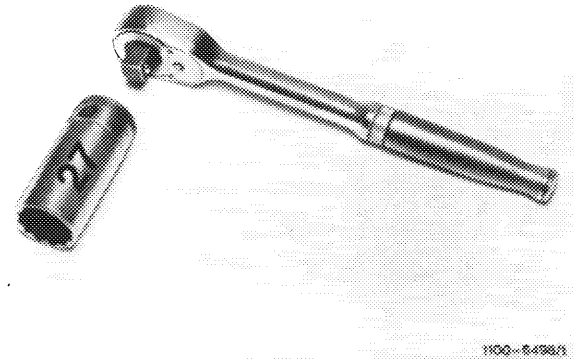

b) With starter motor and contact handle

Connect contact handle to cable connector, terminal 30 and 50.

The cable connector is located at the following points:

Model 116.120: Under battery.

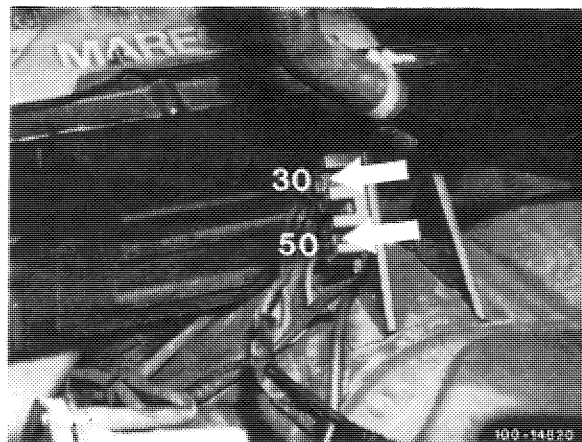

Model 116.120

Model 123: At right on wheel house.

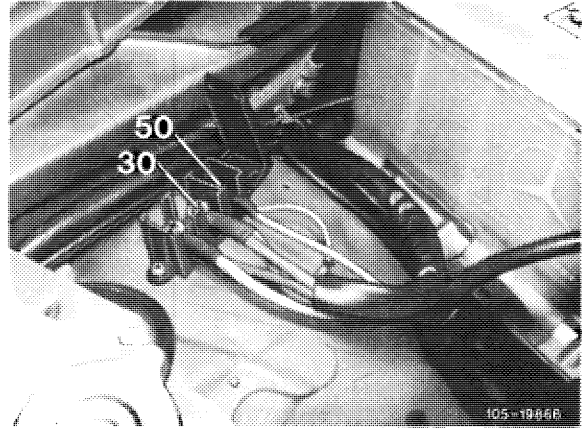

Model 123

Model 126.120: On frame side member.

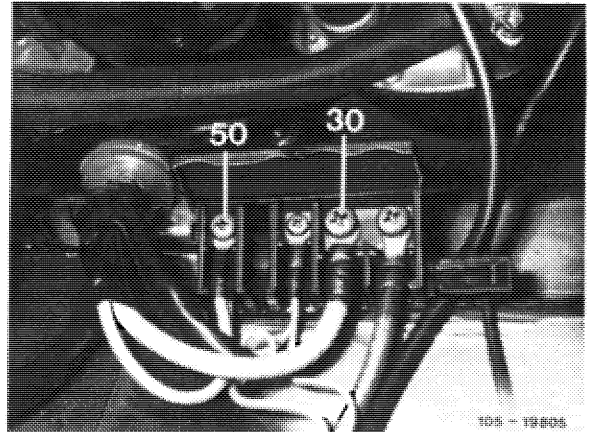

Model 126.120

3 Place holding wrench on valve spring retainer.

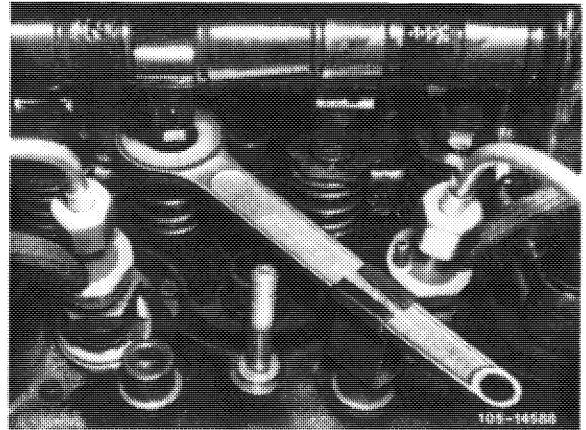

4 Loosen cap nut while applying counterhold to counternut on valve by means of valve adjusting wrench.

5 Adjust valve clearance by turning cap nut.

6 Following adjustment, secure cap nut with counternut (torque reference value 20–30 Nm).

7 Check valve clearance once again.

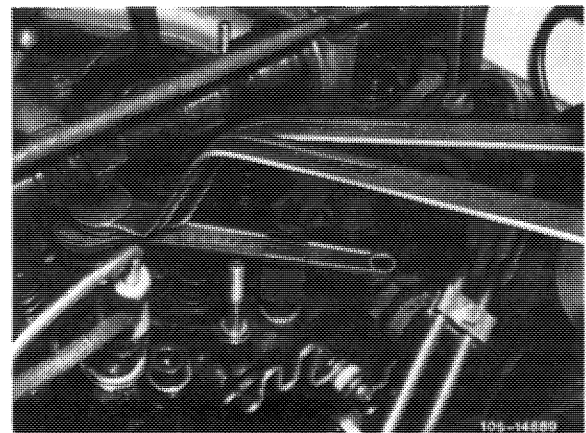

Timing at 2 mm valve lift

Engine	Camshaft code number ¹⁾	Intake valve opens after TDC	closes after BDC	Exhaust valve opens before BDC	closes before TDC
617.950 ²⁾	00 08 ⁴⁾	with new timing chain			
		11.5°	13.5°	21°	19°
		with used timing chain (from approx. 20 000 km)			
		13.5°	15.5°	19°	17°
617.950 ³⁾ 617.951 617.952	05 ⁴⁾	with new timing chain			
		9°	15°	27°	16°
		with used timing chain (from approx. 20 000 km)			
		11°	17°	25°	14°

1) Camshaft code number is punched into rear end of camshaft.

2) up to model year 1979.

3)  model year 1980.



4) Camshaft made of chilled cast iron.

Valve clearance	with engine cold (approx. 20 °C)	with engine warm (60 °C ± 15 °C)
Intake	0.10 ¹⁾	0.15 ¹⁾
Exhaust	0.35	0.40

1) 0.05 mm higher during lasting outside temperatures below –20 °C.

Tightening torques	Nm
Nuts for cylinder head cover	15
Necked-down screw for camshaft sprocket	80
Closing plug for chain tensioner	90

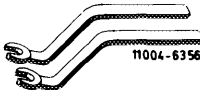
Special tools

Valve adjusting wrench 14 mm (2 each)		615 589 00 01 00
Holding wrench for valve spring retainer		615 589 00 03 00
Slip gage holder, red		617 589 00 40 00
Slip gage blades	0.10 mm thick	617 589 00 23 00
	0.15 mm thick	617 589 01 23 00

Socket 27 mm, 1/2" square,
for rotating engine

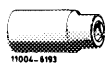

001 589 65 09 00

Dial gage holder

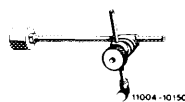

363 589 02 21 00

Impact puller for bearing bolt
(basic unit)

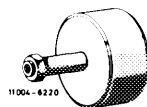

116 589 20 33 00

Threaded bolt for impact puller M 6,
50 mm long



116 589 01 34 00

Conventional tool

Dial gage A 1 DIN 878

e.g. made by Mahr, D-7300 Esslingen
Order No. 810

Note

During assembly jobs, alignment of the markings (arrow) in ignition TDC position of 1st cylinder will be sufficient.

In special cases, e.g. during complaints about performance, check and adjust begin of opening at intake valve of 1st cylinder.

Timing is measured at 2 mm valve lift. For this purpose, the valve clearance must be neutralized.

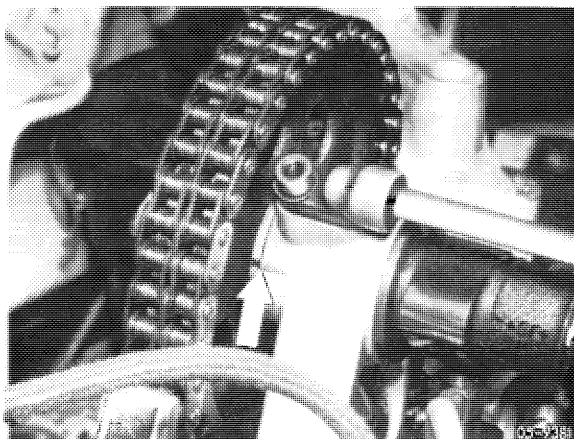

Checking

1 Unscrew pencil element glow plugs.

2 Disconnect regulating linkage to remove cylinder head cover. Pull out locking eye of longitudinal regulating shaft (arrow).

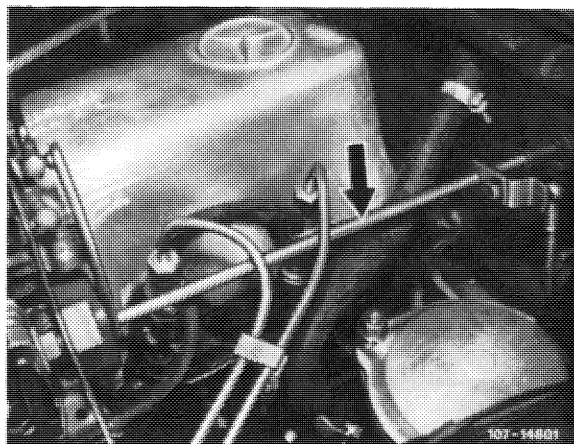

Model 116.120

On models 116.120 and 123, pull longitudinal regulating shaft out of rubber mount in forward direction and remove in rearward direction.

On model 126.120, pull longitudinal regulating shaft out of guide lever in rearward direction and remove in forward direction.

Model 123

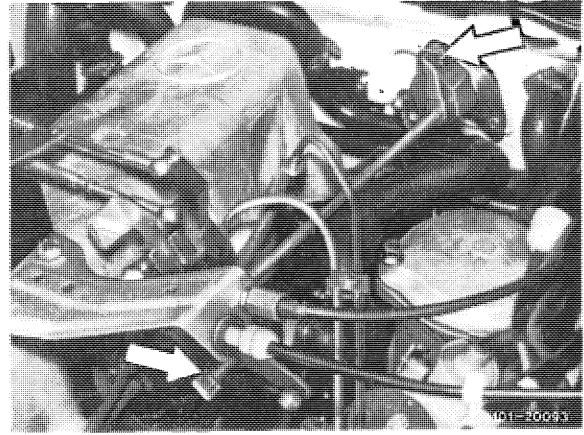

On models 123 with automatic transmission 722.303 (W 4 A 040) and 126.120, pull off central plug for vacuum lines (71) or vacuum lines. Disconnect Bowden wire, compress black plastic clip (arrow) and pull Bowden wire out of holder in rearward direction.

Model 126.120

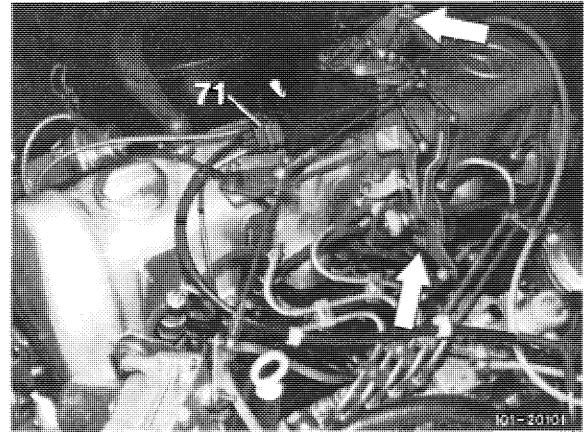

3 Rotate crankshaft with tool combination until cam tip is pointing upwards.

Attention!

Do not rotate engine on fastening screw of camshaft sprocket. Never rotate engine in reverse while measuring, since this will result in considerable measuring faults.

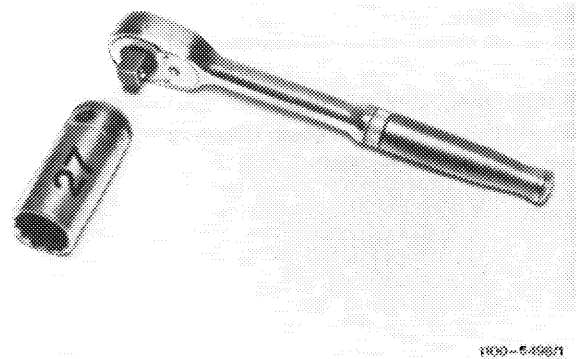

4 Just cancel valve clearance at intake valve of 1st cylinder by screwing up cap nuts (05-210).

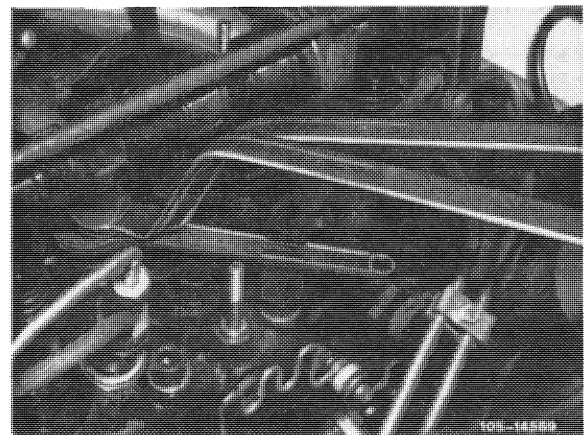

5 Screw dial gage holder with threaded sleeve to stud at front right.

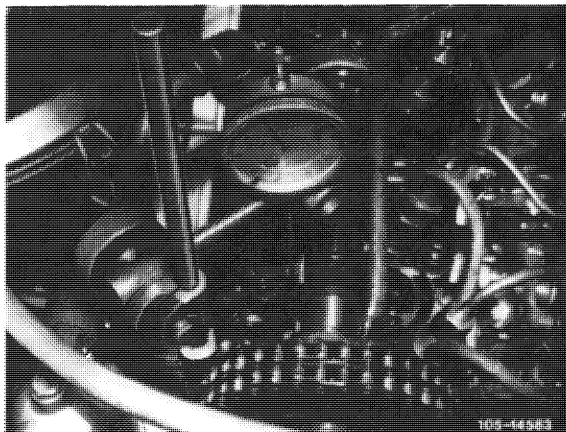

6 Insert dial gage and fasten in such a manner that the feeler pin rests on valve spring retainer at a preload of 3 mm (small needle of dial gage) (arrow).

Turn dial of dial gage until large needle rests on "0".

Attention!

Feeler pin of dial gage should be seated on valve spring retainer in accurately vertical position.

7 Keep turning crankshaft in direction of rotation of engine until small needle of dial gage has gone back by 2 mm (valve lift) to 1 mm.

In this position, the value on balancing disk should be in agreement with the indicated value "intake valve opens".

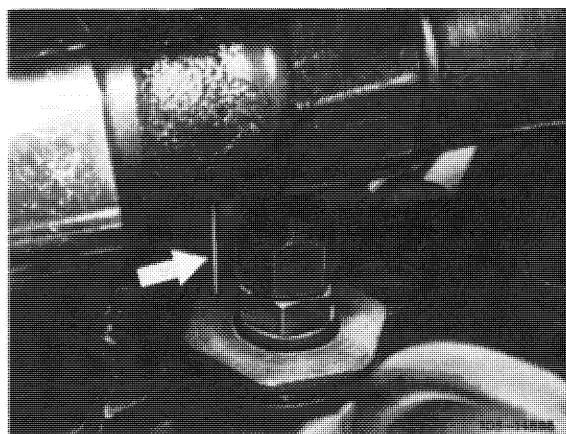

Adjustment

If the timing requires correction, install an offset Woodruff key or, if the chain is excessively elongated, install a new timing chain.

Woodruff keys are available in the following steps:

Offset mm	Part No.	for a correction of approx.
0.7	621 991 04 67	4° crankshaft
0.9	621 991 02 67	6 1/2° crankshaft
1.1	621 991 01 67	8° crankshaft
1.3	621 991 00 67	10° crankshaft

An offset by one tooth on camshaft sprocket results in approx. 18° at crankshaft.

An offset of Woodruff keys to the right (in driving direction [A]) results in an earlier begin of opening, and an offset to the left (B) in a later begin of opening.

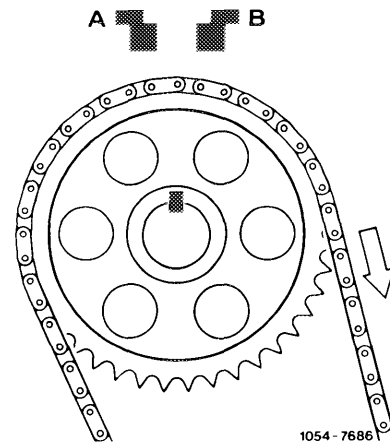

8 Set engine to ignition TDC of 1st cylinder.

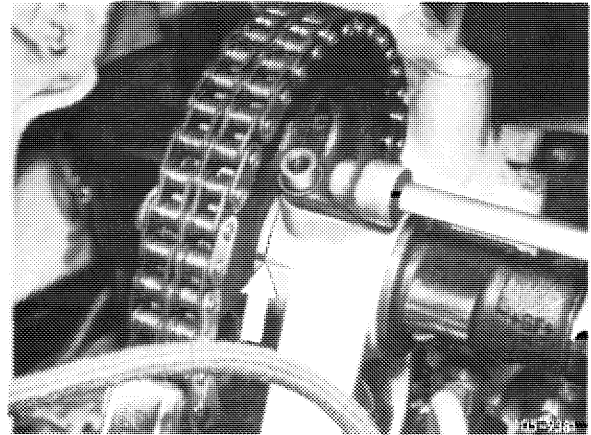

9 On engines with EGR (USA), remove pipe line between EGR valve and exhaust manifold (arrow). Unscrew shielding plate (10) for this purpose.

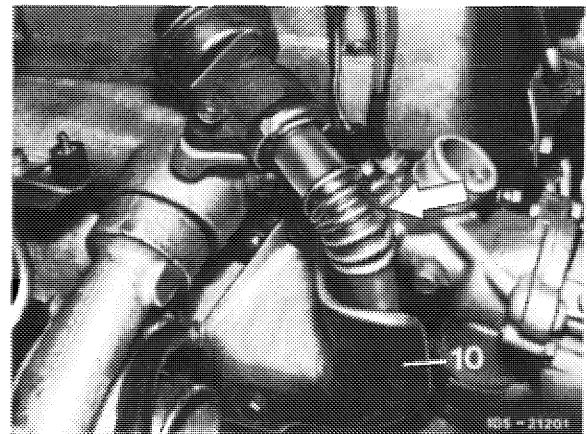

10 Unscrew closing plug of chain tensioner and remove compression spring (05-310).



11 Remove slide rail in cylinder head. Pull out bearing bolt by means of impact puller.

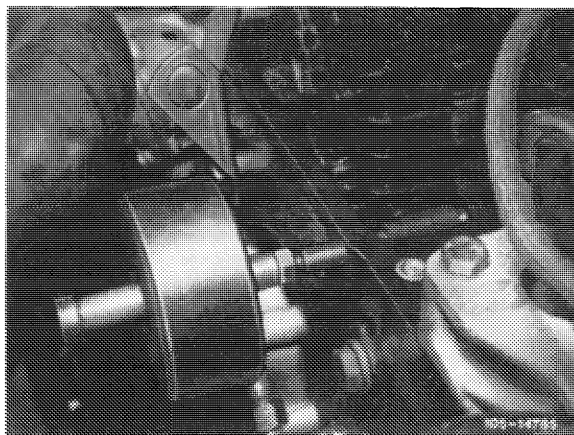
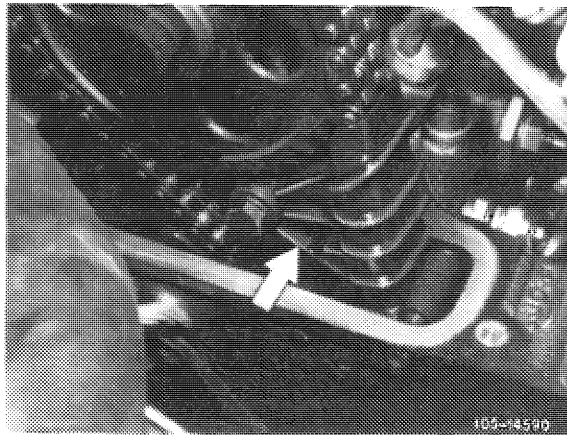

12 Mark camshaft sprocket and timing chain in relation to each other.

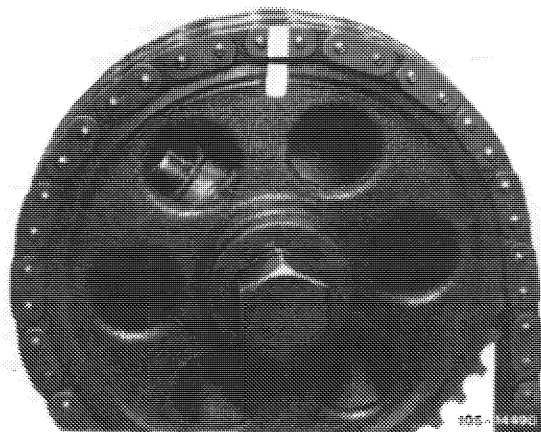

13 Remove camshaft sprocket.

To loosen necked-down screw of camshaft sprocket, apply counterhold with a screwdriver or steel pin.

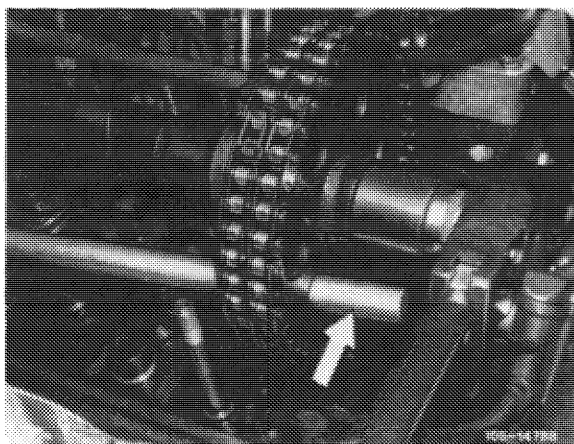

14 Place rag under camshaft and remove Woodruff key.

15 Insert selected Woodruff key.

16 Mount camshaft sprocket while paying attention to color marks.

Do not tighten necked-down screw.

17 Repeat item 6 and 7.

18 Tighten necked-down screw for fastening camshaft sprocket to 80 Nm. For this purpose, apply counterhold to camshaft sprocket by means of a screwdriver or a steel pin.

19 Install slide rail.

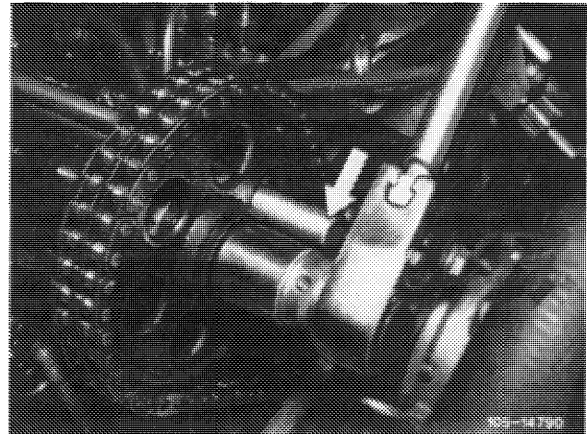

20 Place compression spring into chain tensioner and tighten closing plug to 90 Nm.

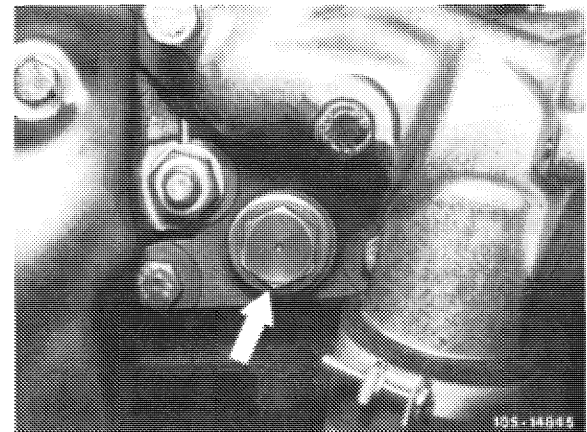

21 Unscrew dial gage holder.

22 Adjust valve clearance at intake valve of 1st cylinder (05–210).

23 On engines with EGR (USA), install pipe line between EGR valve and exhaust manifold. Screw on shielding plate.

24 Mount cylinder head cover.

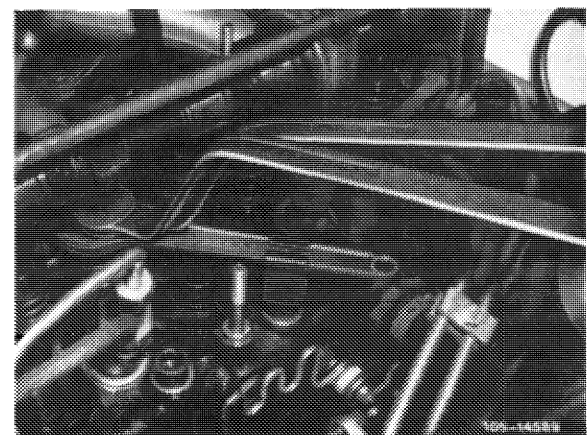

Timing at 2 mm valve lift

Engine	Camshaft code number ¹⁾	Intake valve		Exhaust valve		
		opens after TDC	closes after BDC	opens before BDC	closes before TDC	
617.950 ²⁾	00 08 ⁴⁾	with new timing chain				
		11.5°	13.5°	21°	19°	
		with used timing chain (from approx. 20 000 km)				
		13.5°	15.5°	19°	17°	
617.950 ³⁾ 617.951 617.952	05 ⁴⁾	with new timing chain				
		9°	15°	27°	16°	
		with used timing chain (from approx. 20 000 km)				
		11°	17°	25°	14°	

1) Camshaft code number is punched into rear end of camshaft.

2)  up to model year 1979.

3)  model year 1980.

4) Camshaft made of chilled cast iron.

Valve clearance	with engine cold (approx. 20 °C)	with engine warm (60 °C ± 15 °C)
Intake	0.10 ¹⁾	0.15 ¹⁾
Exhaust	0.35	0.40

1) 0.05 mm higher during lasting outside temperatures below -20 °C.

Data

Permissible runout of center bearing journal and camshaft sprocket seat when mounting camshaft in outer bearing journals	Camshaft code number	00	05, 08
	Camshaft sprocket seat		0.020
2nd bearing point		0.030	0.030
3rd bearing point		0.025	0.030
Scleroscope hardness of cams		70-82	64-75

Tightening torques

	Nm	
Nuts for cylinder head cover	15	
Camshaft bearing bolts (hex. socket cylinder head bolts)	100	
Camshaft bearing bolts (double hex. socket cylinder head bolts)	1st stage	40
	2nd stage	70
	3rd stage	90°
	4th stage	90°

Nuts M 8 for camshaft bearings	25
Necked-down screw for camshaft sprocket	80
Rocker arm bearing brackets to cylinder head	40

Special tools

Socket 27 mm, 1/2" square, for rotating engine  001 589 65 09 00

Screwdriver socket 10 mm, 1/2" square, 140 mm long for hex. socket cylinder head bolts  000 589 05 07 00

Screwdriver socket 1/2" square, 140 mm long for double hex. socket cylinder head bolts  617 589 00 10 00

Valve adjusting wrench 14 mm (2 each)  615 589 00 01 00

Holding wrench for valve spring retainer  615 589 00 03 00

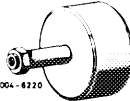
Impact puller for bearing bolt (basic unit)  116 589 20 33 00

Threaded bolt for impact puller M 6, 50 mm long  116 589 01 34 00

Dial gage holder  363 589 02 21 00

Contact handle for rotating engine (component of compression pressure recorder 001 589 46 21 00)  001 589 46 21 08

Conventional tool

Dial gage A 1 DIN 878

e.g. made by Mahr, D-7300 Esslingen
Order No. 810

Note

When installing a new camshaft, also renew rocker arms on principle.

Of rocker arms with carbide facing, replace damaged rocker arms only.

The larger cylinder charge required for engine 617.950 (USA) model year 1980 with increased output and on engines 617.951/952 has been obtained by increasing the valve lift.

For this purpose, the intake and exhaust cams on camshaft have been modified with regard to height (H) and shape.

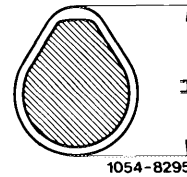

Valve lift on engine 617.950 (USA) model year 1980 with increased output and on engines 617.951/952.

Intake	10.0 mm
Exhaust	10.4 mm

Valve lift on engine 617.950 (USA) without increased output up to model year 1979.

Intake and exhaust 8.5 mm

Since the above measures result in higher loads on camshafts, a different materials pairing between camshaft and rocker arm has been required.

Camshafts of engine 617.950 (USA) model year 1980 with increased output and of engines 617.951/952 (code number 05) are made of chilled cast iron, and the sliding surface of the respective rocker arms is provided with a brazed-on carbide facing (B, arrow).

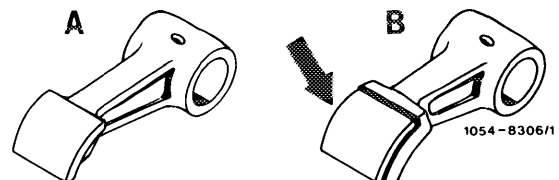

- A Rocker arm inductance-hardened and hard-chromed
- B Rocker arm with carbide facing

Because of the larger valve lift (higher cams) and in order to permit installation of camshaft, the bearing diameter (D) at camshaft bearings 2, 3 and 4 had to be increased by 2.5 mm. Accordingly, the diameter of bearing journals 2, 3 and 4 of camshaft has also been increased by 2.5 mm.

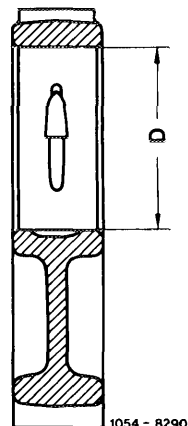

Camshaft bearings 2, 3 and 4

Engines without increased output D = 46.5 mm
Engines with increased output D = 49.0 mm

In addition, camshaft bearings 2, 3 and 4 have been reinforced (B).

On the other hand, the diameter of the first camshaft bearing and the first camshaft bearing journal has remained the same.

Since the wear characteristics of camshafts made of chilled cast iron are better than those made of malleable cast iron, the malleable cast iron camshaft (code number 00) for engine 617.950 (USA) for model year 1979 without increased output has been replaced by the chilled cast iron camshaft (code number 08) (refer to table).

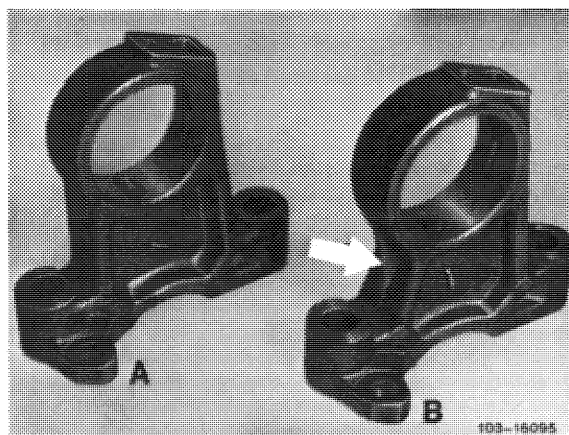

This camshaft also includes the rocker arms with carbide facing.

Installation: June 1979

Model	Engine	Engine end No.	Chassis end No.
116.120	617.950	010606	010351

The chilled cast iron camshafts (code number 05 and 08) may be installed only together with the carbide-faced rocker arms.

Rocker arms with carbide facing may not be installed together with malleable cast-iron camshaft (code number 00).

It is also not permitted to install engine 617.950 (USA) model year 1980 with increased output and engines 617.951/952 on engine 617.950 (USA) up to model year 1979.

Simultaneously with the changeover to chilled cast iron camshaft and rocker arms with carbide facing, the cap nuts in upper range were reinforced and hard-chromed (B).

They may be installed on all rocker arm versions.

On the other hand, the non-chrome-plated cap nut may not be used for rocker arm with carbide facing.

- A Cap nut without chrome plating
- B Cap nut with chrome plating

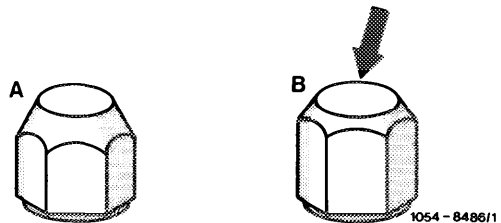

Chilled cast iron camshafts are sensitive to fracture and should not be knocked against, struck or thrown.

Camshafts on which flats are showing up on cams (arrow) should be replaced.

The timing should be checked on engines after a long period of operation (extensive elongation of chain) (05-215).

Worn out camshaft bearing journals may be reground. The required camshaft bearings are available in two repair stages (05-225).

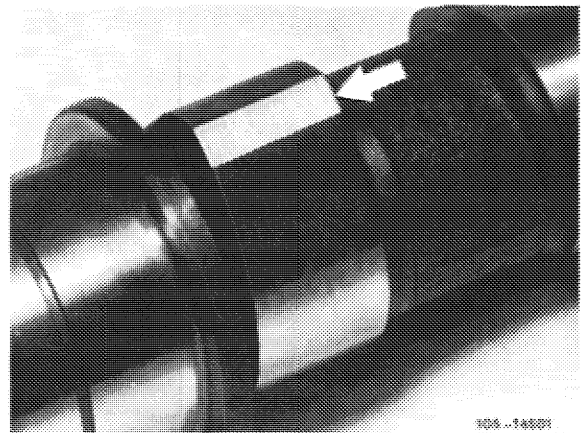

Removal

1 Disconnect regulating linkage to remove cylinder head cover. Pull out locking eye of longitudinal regulating shaft (arrow).

Model 116.120

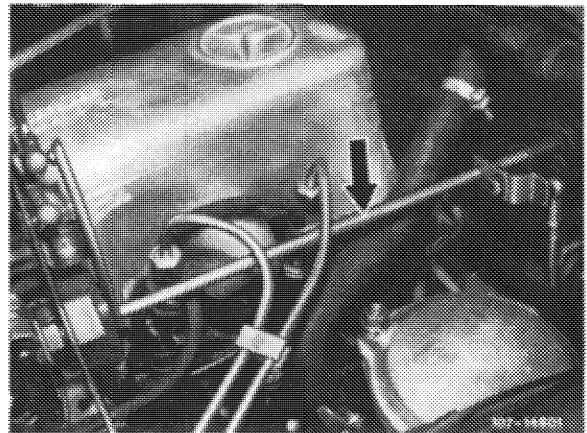

On models 116.120 and 123, pull longitudinal regulating shaft out of rubber mount in forward direction and remove in rearward direction.

On model 126.120, pull longitudinal regulating shaft out of guide lever in rearward direction and remove in forward direction.

Model 123

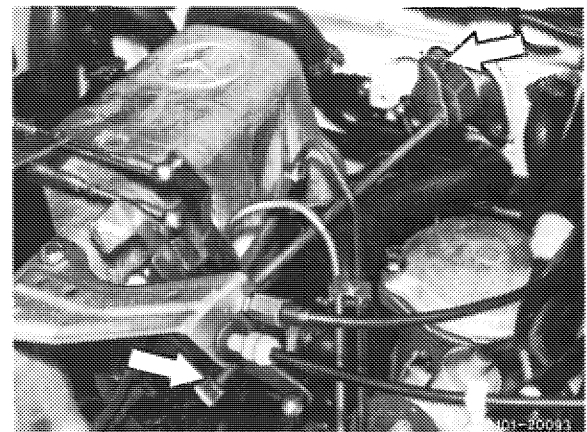

On models 123 with automatic transmission 722.303 (W 4 A 040) and 126.120, pull off central plug for vacuum lines (71) or vacuum lines. Disconnect Bowden wire, compress black plastic clip (arrow) and pull Bowden wire out of holder in rearward direction.

Model 126.120

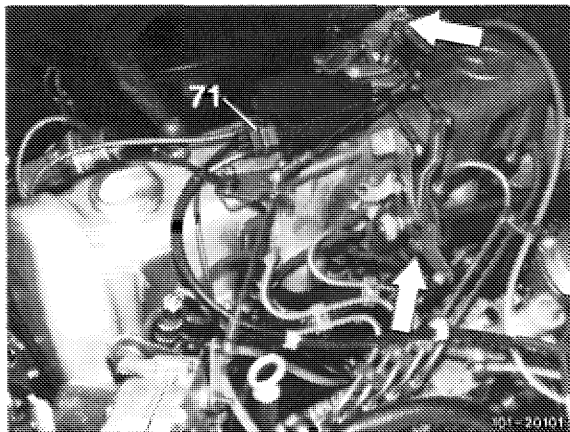

2 Remove rocker arms together with rocker arm brackets (05-235).

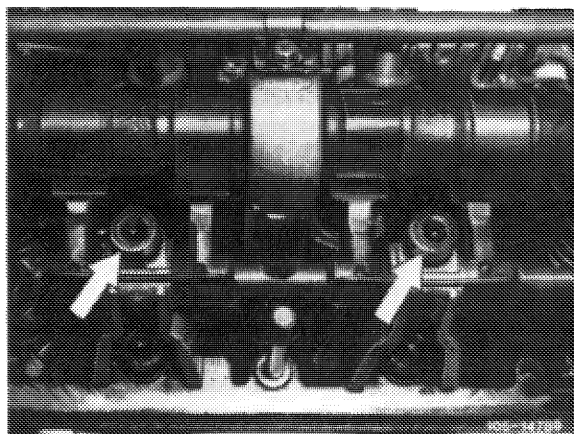

3 Remove slide rail in cylinder head. Pull out bearing bolt by means of impact puller.

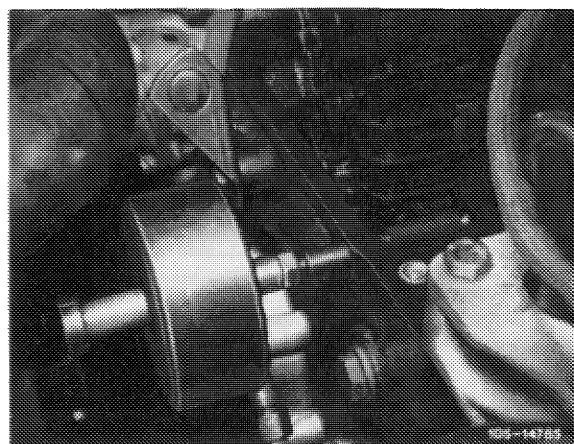
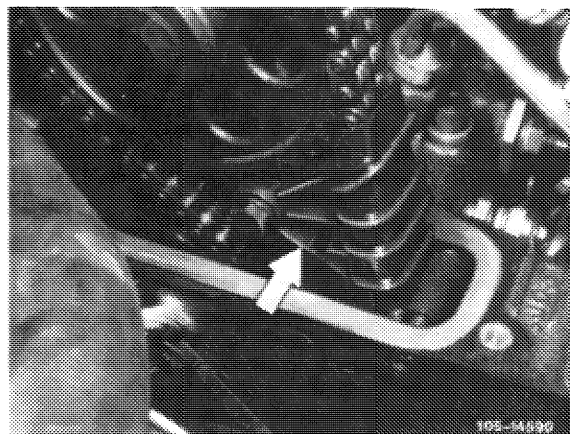

4 On engines with EGR (USA), remove pipe line between EGR valve and exhaust manifold (arrow). Unscrew shielding plate (10) for this purpose.

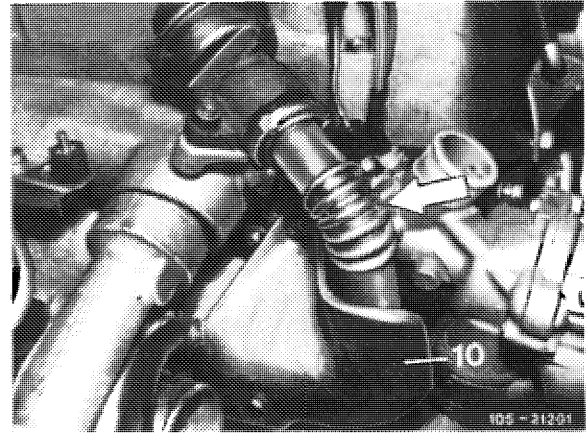

5 Unscrew closing plug of chain tensioner and remove compression spring (05-310).

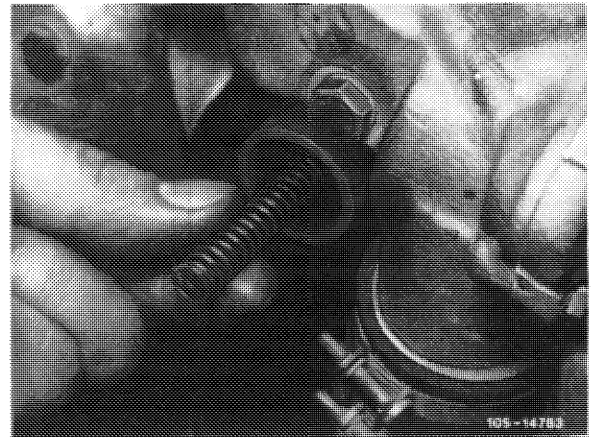

6 Set crankshaft to ignition TDC.

Rotate crankshaft with tool combination for this purpose.

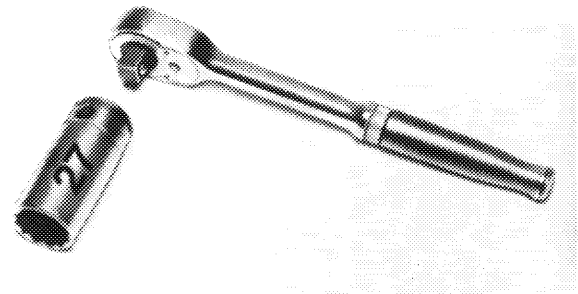

7 Mark camshaft sprocket and timing chain in relation to each other.

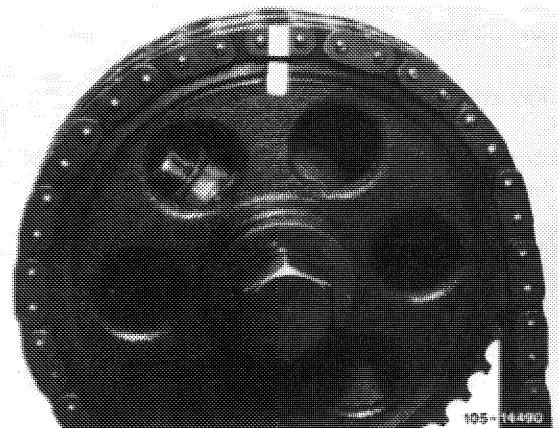

8 Remove camshaft sprocket.

To loosen necked-down screw, apply counterhold to camshaft sprocket by means of a screwdriver or a steel bolt.

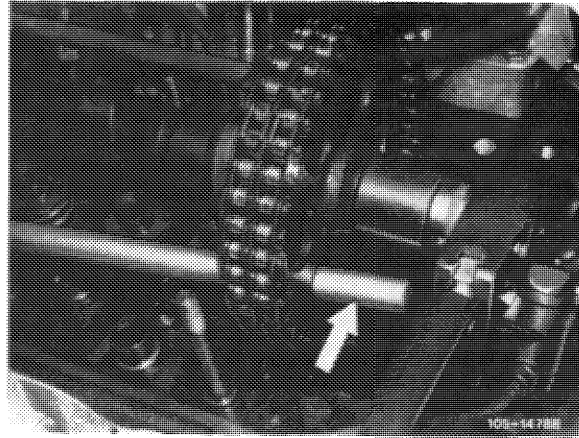

9 Remove compensating washer.

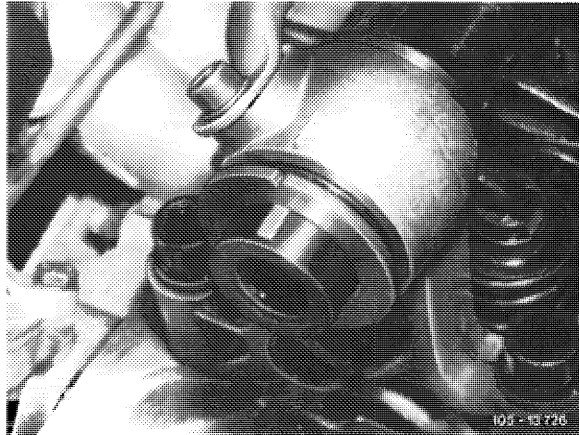

10 Unscrew camshaft bearing screws by means of screwdriver socket (10 mm).

Unscrew nuts M 8.

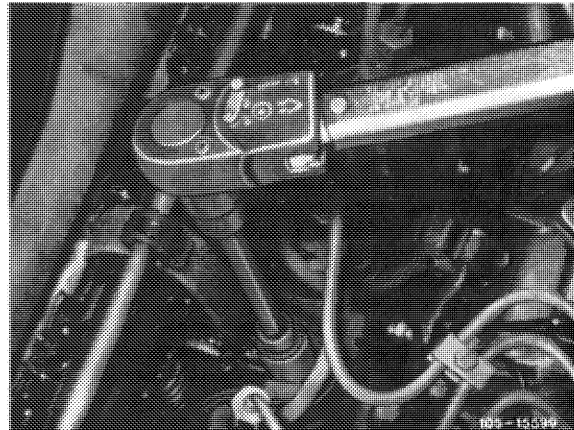

11 Remove camshaft together with camshaft bearings and oil pipe.

Pay attention to dowel pins.

Loosen stuck camshaft bearings by means of light blows with a plastic hammer.

12 Pull camshaft out of camshaft bearings in rearward direction.

Installation

13 Provide camshaft bearings, camshaft bearing journals and cams with engine oil.

14 Slip camshaft from the rear into camshaft bearings.

15 Mount camshaft with camshaft bearings and oil pipe.

Pay attention to dowel pins.

16 Tighten camshaft bearing bolts (cylinder head bolts) from inside out as specified (refer to table).

On engines with hex. socket cylinder head bolts, slightly loosen the remaining 14 cylinder head bolts also from inside out **individually** and tighten to 100 Nm.

Tighten M 8 nuts to 25 Nm.

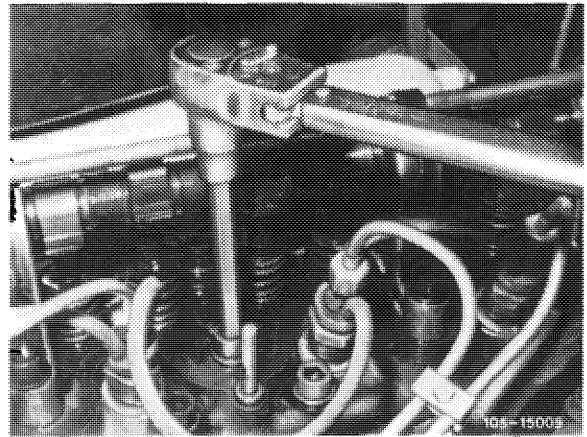

17 Rotate camshaft manually to check for easy operation.

If camshaft is hard to rotate, proceed as follows:

Loosen camshaft bearings individually. Then rotate camshaft each time.

Repeat until the binding bearing point is found. Depending on sag of camshaft, touch up pertinent camshaft bearing at base (arrows) on a surface plate.

18 Slip compensating washer on journal for camshaft sprocket.

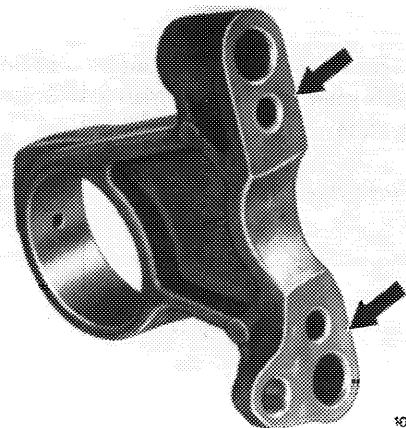

19 Mount camshaft sprocket. Pay attention to color marks.

Tighten necked-down screw to 80 Nm. For this purpose, apply counterhold to camshaft sprocket by means of a screwdriver or steel bolt.

20 Install slide rail.

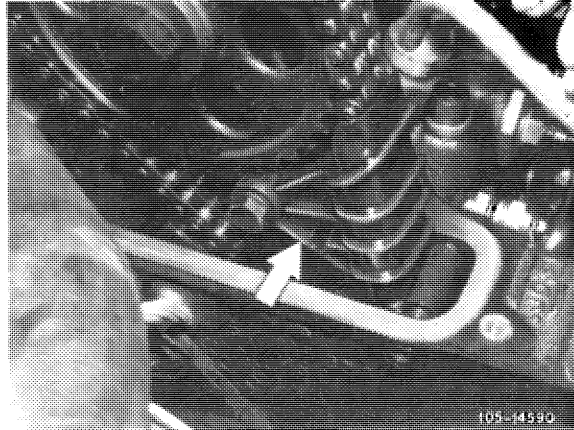

21 Place compression spring into chain tensioner and tighten closing plug to 90 Nm.

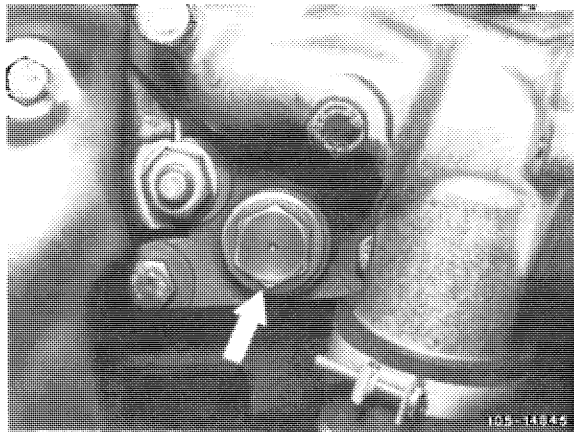

22 Install rocker arms together with rocker arm bearing brackets (05-235).

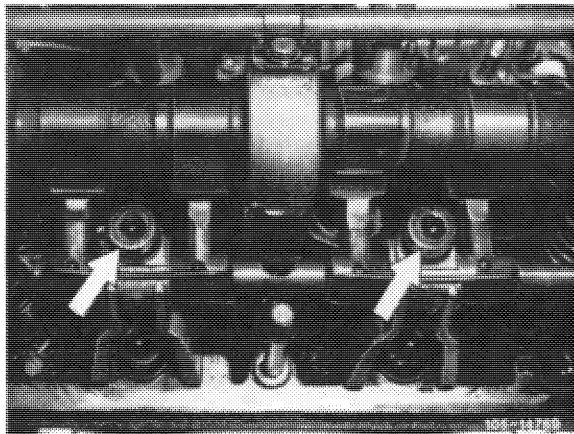

23 Adjust valve clearance (05-210).

24 On engines with EGR (USA), install pipe line between EGR valve and exhaust manifold. Screw on shielding plate.

25 Mount cylinder head cover.

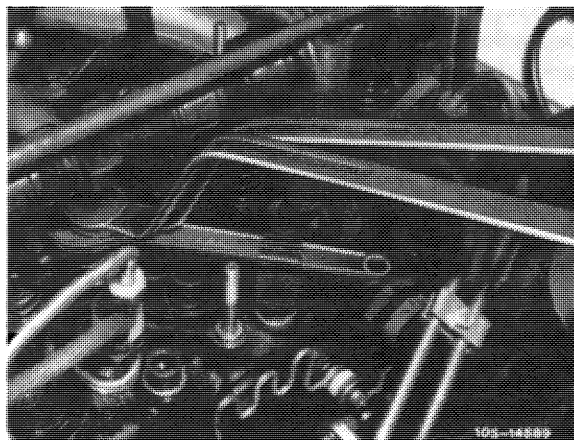

Camshaft and camshaft bearings

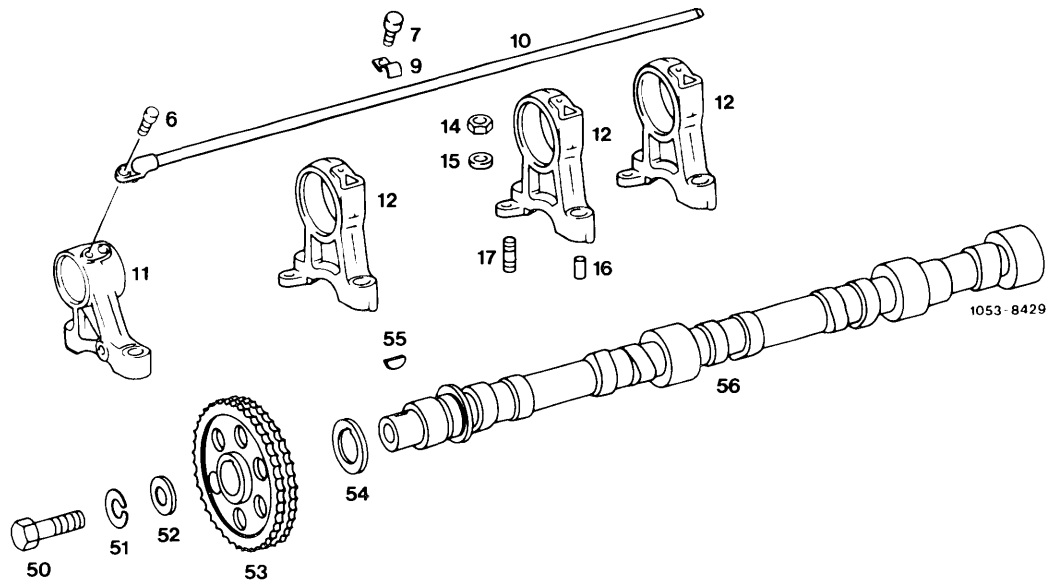

- | | | | | | |
|----|-------------------------------|----|-----------------------------------|----|---------------------|
| 6 | Combination screw M 6 x 12 | 14 | 4 nuts M 8 | 52 | Washer |
| 7 | 3 combination screws M 5 x 10 | 15 | 4 washers 8.4 | 53 | Camshaft sprocket |
| 9 | 3 fastening clamps | 16 | 8 cylindrical pins 8 x 8 | 54 | Compensating washer |
| 10 | Oil pipe | 17 | 4 studs M 8 x 18 | 55 | Woodruff key |
| 11 | Camshaft bearing crank end | 50 | Necked-down screw M 14 x 1.5 x 40 | 56 | Camshaft |
| 12 | Camshaft bearing | 51 | Snap ring B 14 | | |

Data

Roughness of camshaft bearing journals		0.003		
Permissible runout of center bearing journals and camshaft sprocket seat when mounting camshaft at outer bearing journals	Camshaft code number ¹⁾	00	05, 08	
	Camshaft sprocket seat	0.020	0.025	
	2nd bearing point	0.030	0.030	
	3rd bearing point	0.025	0.030	
Scleroscope hardness of cams		70—82	64—75	
Bearing points (Fig.)		a	b, c and d	
Standard dimension	Camshaft bearing dia.	<u>35.00</u>	<u>46.50</u>	<u>49.00</u> ²⁾
		35.02	46.52	49.02
	Journal dia.	<u>34.95</u>	<u>46.45</u>	<u>48.95</u> ²⁾
		34.93	46.43	48.93
Intermediate stage	Camshaft bearing dia. (color code grey)	<u>34.90</u>	<u>46.40</u>	<u>48.90</u> ²⁾
		34.92	46.42	48.92
	Journal dia.	<u>34.85</u>	<u>46.35</u>	<u>48.85</u> ²⁾
		34.83	46.33	48.83
Repair stage I	Camshaft bearing dia. (color code red)	<u>34.75</u>	<u>46.25</u>	<u>48.75</u> ²⁾
		34.77	46.27	48.77
	Journal dia.	<u>34.70</u>	<u>46.20</u>	<u>48.70</u> ²⁾
		34.68	46.18	48.68
Width A of journal a (Fig.)		<u>34.00</u>	—	
		34.04		
Bearing play	radial	0.050—0.084		
	axial	0.07—0.15		

¹⁾ Code number is punched into rear end of camshaft.

²⁾ Camshaft bearings and journal dia. on engine 617.950(USA) model year 1980 with increased output and engines 617.951/952.

Special tool

Dial gage holder for end play of camshaft (2 each)

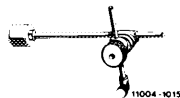

363 589 02 21 00

Conventional tool

Dial gage A 1 DIN 878

e.g. made by Mahr, D-7300 Esslingen
Order No. 810

Note

In the event of repairs, regrind camshaft in accordance with available camshaft bearings.

Camshaft bearing journals are not hardened.

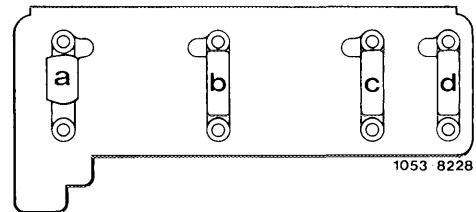

If dimension A is exceeded when grinding 1st bearing journal, also regrind face a.

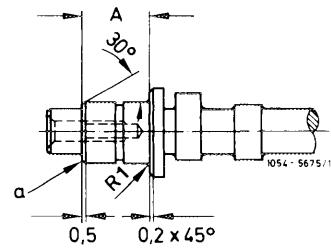

Measuring end play

- 1 Screw on dial gage holder with threaded sleeve at front left.
- 2 Position dial gage at approx. 3 mm preload against thrust flange of camshaft.
- 3 Push camshaft toward the rear and set large needle to zero.

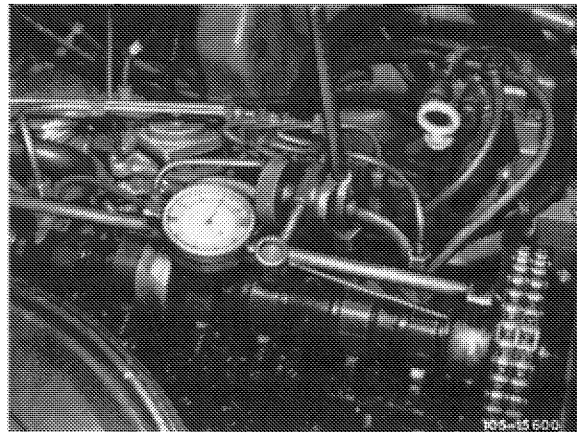

- 4 Push camshaft forward and determine end play.

Note: If the end play is too low, touch up 1st camshaft bearing at its face surfaces (arrow).

If the end play is too high, regrind face a on 1st bearing journal of camshaft.

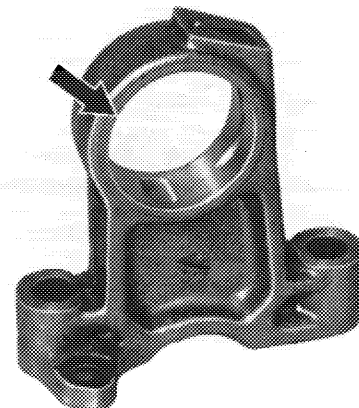

105-14778/1

05–235 Removal and installation of rocker arms with rocker arm bearing brackets

Valve clearance	with engine cold (approx. 20 °C)	with engine warm (60 °C ± 15 °C)
Intake	0.10 ¹⁾	0.15 ¹⁾
Exhaust	0.35	0.40

¹⁾ 0.05 mm higher during lasting outside temperatures below –20 °C.

Tightening torques	Nm
Nuts for cylinder head cover	15
Rocker arm bearing brackets to cylinder head	38

Special tools

Valve adjusting wrench 14 mm
(2 each)

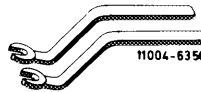

615 589 00 01 00

Holding wrench for valve
spring retainer



615 589 00 03 00

Socket 27 mm, 1/2" square, for
rotating engine

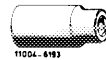

001 589 65 09 00

Contact handle for rotating engine
(component of compression pressure
recorder 001 589 46 21 00)

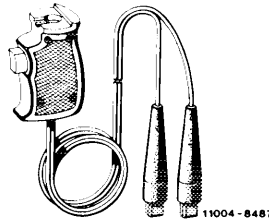

001 589 46 21 08

Note

Always install rocker arm at the same spot from where it has been removed.

If the rocker arms are renewed, also renew camshaft.

On rocker arms with carbide facing, renew damaged rocker arm only.

Removal

1 Disconnect regulating linkage to remove cylinder head cover. Pull out locking eye of longitudinal regulating shaft (arrow).

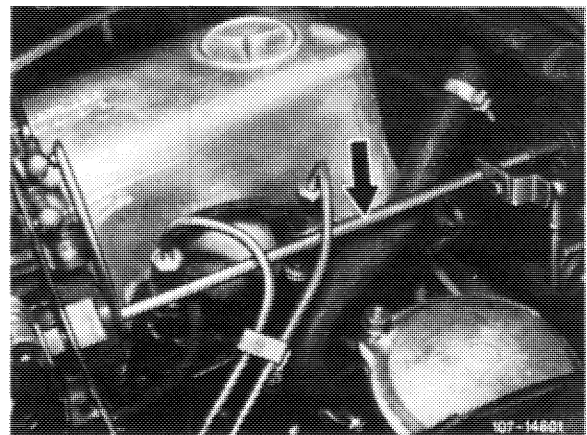

Model 116.120

On models 116.120 and 123, pull longitudinal regulating shaft out of rubber mount in forward direction and remove in rearward direction.

On model 126.120, pull longitudinal regulating shaft out of guide lever in rearward direction and remove in forward direction.

Model 123

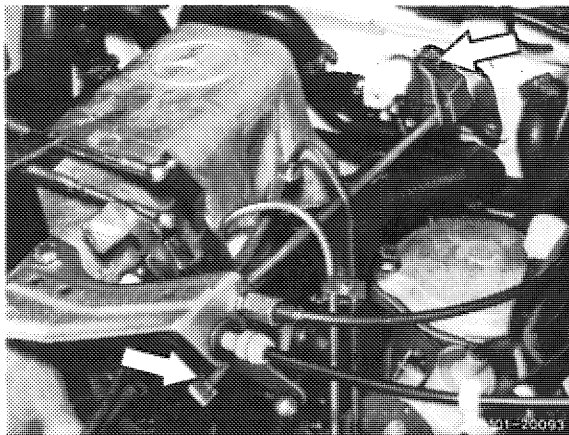

On models 123 with automatic transmission 722.303 (W 4 A 040) and 126.120, pull out central plug of vacuum lines (71) or vacuum lines. Disconnect Bowden wire, compress black plastic clip (arrow) and pull Bowden wire out of holder in rearward direction.

Model 126.120

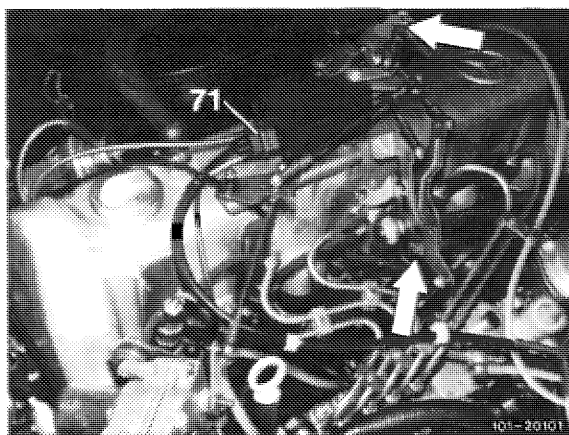

2 Set camshaft in such a manner that the rocker arm is free of load. That is, the cam tips should point away from rocker arms.

For this purpose, rotate the crankshaft by means of the tool combination.

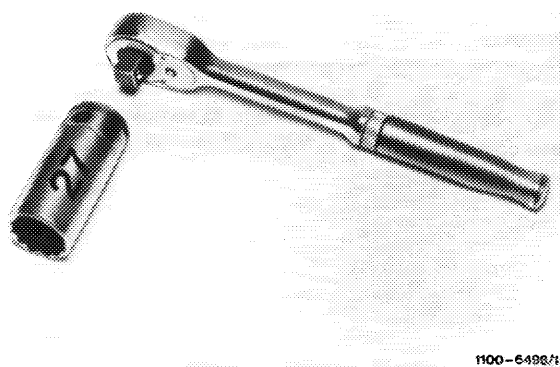
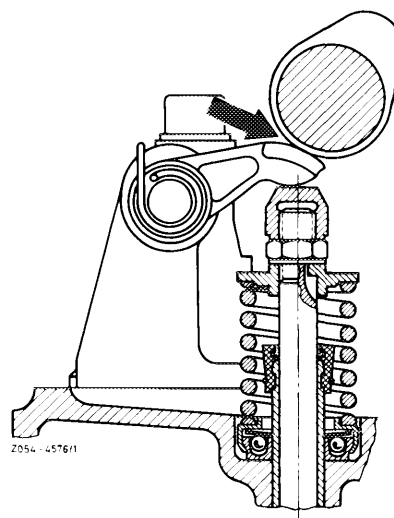

3 Screw out fastening screws of rocker arm bearing brackets (arrows).

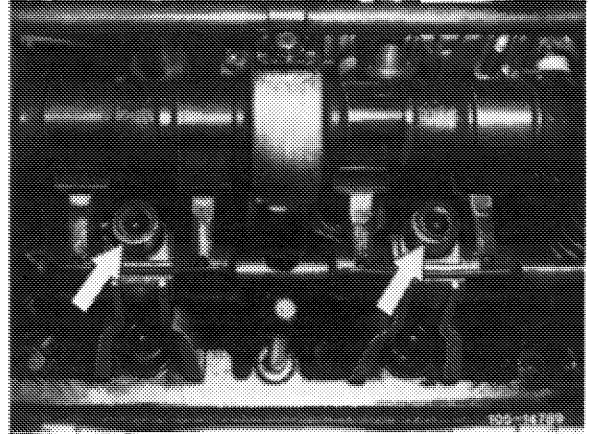

4 Completely remove rocker arm group in upward direction.

Loosen stuck camshaft bearings by means of light blows with a plastic hammer.

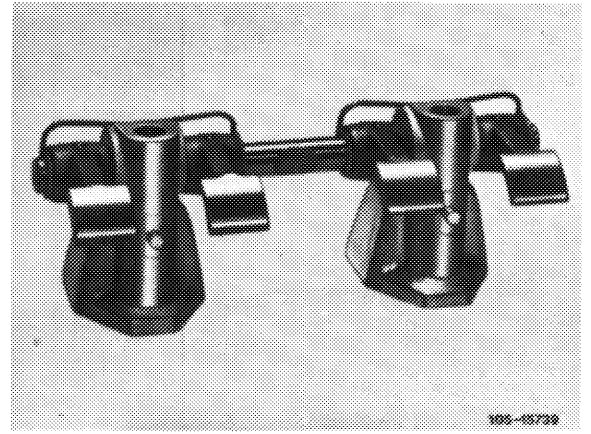

Installation

5 Set complete rocker arm group and screw down.

Note: The rocker arm bearing brackets are located by means of fitted sleeves (arrows).

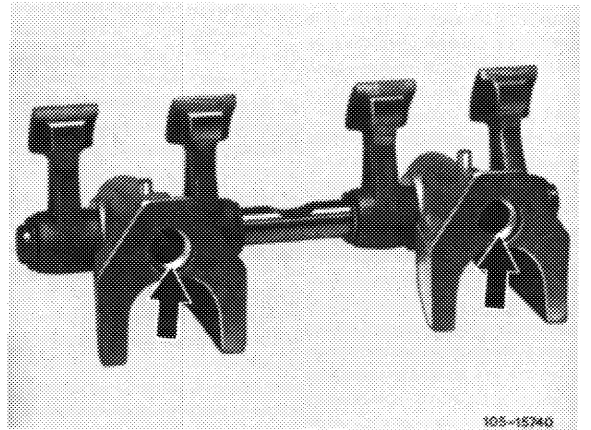

6 Adjust valve clearance (05-210).

7 Mount cylinder head cover.

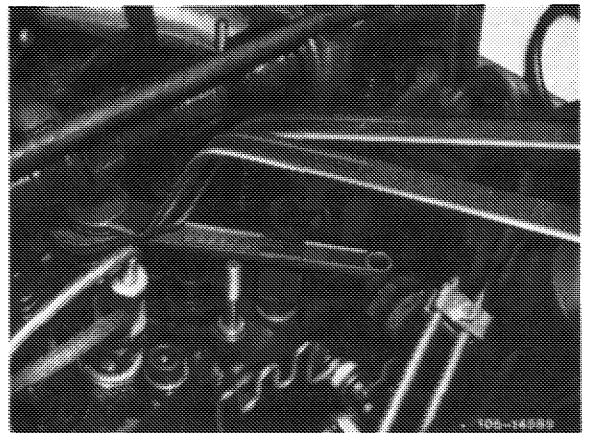

05–240 Renewal of rocker arms and rocker arm bearing brackets



Valve clearance	with engine cold (approx. 20 °C)	with engine warm (60 °C ± 15 °C)
Intake	0.10 ¹⁾	0.15 ¹⁾
Exhaust	0.35	0.40

¹⁾ 0.05 mm higher during lasting outside temperatures below –20 °C.

Rocker arms, rocker arm brackets and shaft

Basic bore in rocker arm		14.00
		14.02
OD of bushing	(open bushing) ≈	14.03
		14.05
ID of bushing	(open bushing)	—
	final dimension	12.00
		12.02
Dia. of rocker arm shaft		11.98
		11.96
Radial play of rocker arm on shaft		0.02–0.06
Bore in rocker arm bearing bracket		11.98
		12.00
Width of rocker arm bearing brackets		24.07–24.20
Tightening torques		Nm
Nuts for cylinder head cover		15
Rocker arm bearing brackets to cylinder head		38

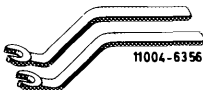
Special tools

Valve adjusting wrench 14 mm (2 each)	 11004-6356	615 589 00 01 00
Holding wrench for valve spring retainer	 11004-7118	615 589 00 03 00
Socket 27 mm, 1/2" square, for rotating engine	 11004-6193	001 589 65 09 00

Contact handle for rotating engine
(component of compression pressure
recorder 001 589 46 21 00)

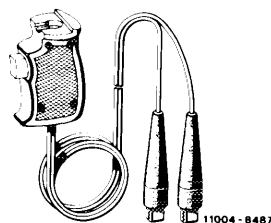

001 589 46 21 08

Note

There are two rocker arm versions:

1st version

Rocker arm with inductance-hardened and hard-chromed running surface (A) for camshaft made of malleable cast iron (code number 00).

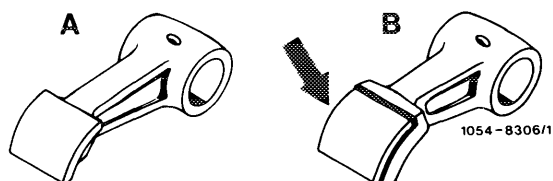

2nd version

Rocker arm with brazed-on carbide facing as running surface (B, arrow), for camshafts made of chilled cast iron (code number 05 and 08).

Code number is punched into rear end of camshaft.

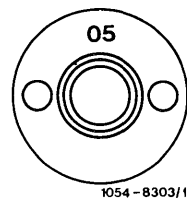

Attention!

Do not mix up rocker arms, since this will lead to destruction of cam and of rocker arm running surface.

During renewal, make sure whether rocker arm has a bushing or not.

Rocker arms without bushing should be scrapped.

On rocker arms with bushings, bushing can be renewed.

Removal

- 1 Completely remove rocker arm groups (05–235).

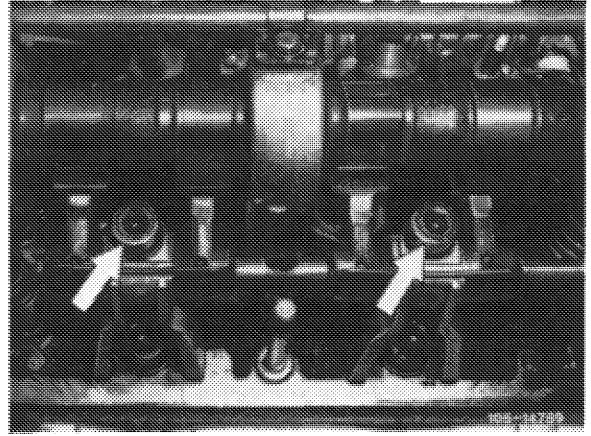

- 2 Push down tensioning springs of rocker arm brackets.

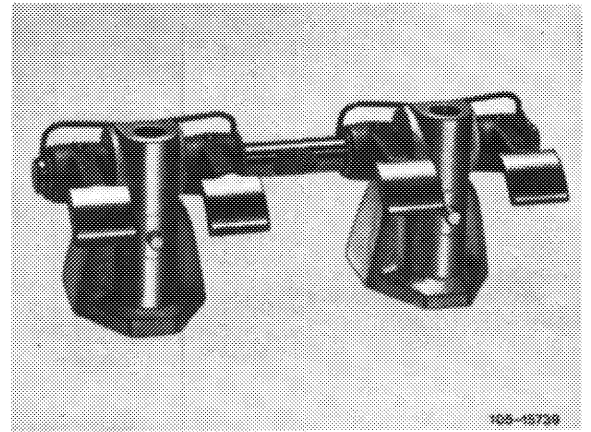

- 3 Pull tensioning spring (57), bearing brackets (65) and rocker arm (59) from rocker arm shaft (58).

- 57 Tensioning spring
- 58 Rocker arm shaft
- 59 Rocker arm
- 59a Rocker arm bearing bushing
- 65 Bearing bracket
- 67 Screw
- 67a Washer
- 68 Fitted sleeve

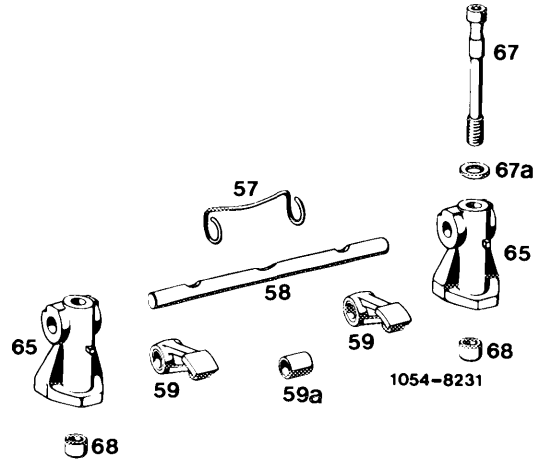

Installation

- 4 Slip tensioning spring (57), rocker arm (59) and bearing brackets (65) on rocker arm shaft (58).
- 5 Slip tensioning spring with second eye on rocker arm shaft and push into groove of bearing brackets.
- 6 Completely install rocker arm groups (05–235).
- 7 Adjust valve clearance (05–210).

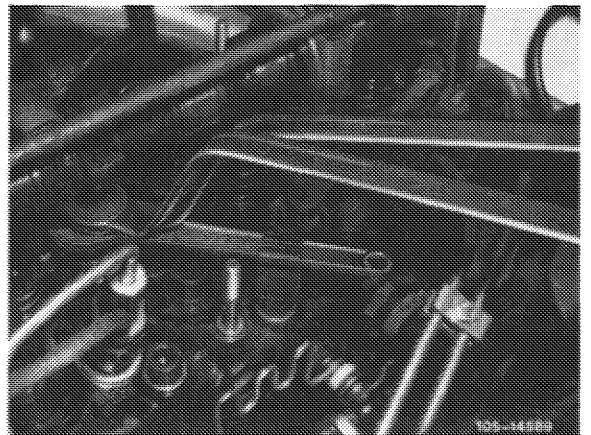



05–250 Removal and installation of valve springs

Valve clearance	with engine cold (approx. 20 °C)	with engine warm (60 °C ± 15 °C)
Intake	0.10 ¹⁾	0.15 ¹⁾
Exhaust	0.35	0.40

¹⁾ 0.05 mm higher during lasting outside temperatures below –20 °C.

Tightening torques	Nm
Nuts for cylinder head cover	15
Rocker arm bearing brackets to cylinder head	38

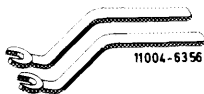
Special tools

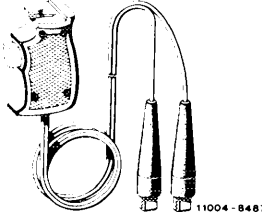
Valve adjusting wrench 14 mm (2 each)		615 589 00 01 00
Holding wrench for valve spring retainer		615 589 00 03 00
Socket 27 mm, 1/2" square, for rotating engine		001 589 65 09 00
Contact handle for rotating engine (component of compression pressure recorder 001 589 46 21 00)		001 589 46 21 08

Note

Each valve has one valve spring (64) and one rotocap (69).

On engines with long service life, it is recommended to renew rotocaps at the same time.

23 Valve guide	66 Valve stem seal
62 Valve spring retainer	69 Rotocap
63 Cap nut	70 Valve
63a Counternut	
64 Valve spring	

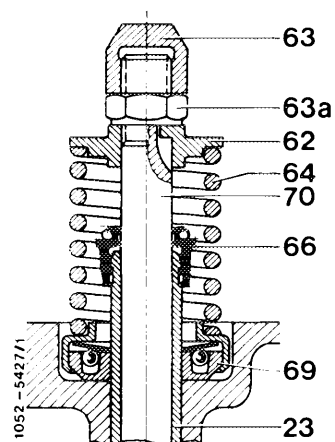

Valve springs with higher spring tension are installed on engine 617.950 since January 1979 and on engines 617.951/952 since start of series (05–260).

On engine 617.950 (USA) starting model year 1980 with increased output and on engines 617.951/952, do not install valve spring, part No. 180 053 06 20.

On the other hand, on engine 617.950 (USA) up to model year 1980 with increased output, valve spring part No. 615 053 01 20 may also be installed.

Start of series

Engine	Starting chassis No.
617.950	006303
617.951/952	start of series

Identification:

Valve spring, part No. 180 053 06 20, two green or purple-green color dots.

Valve spring, part No. 615 053 01 20, two yellow or purple-yellow color dots.

Renew damaged cap nuts (63).

Cap nuts are available in three versions:

1st version

Cap nut with small supporting surface (A).

2nd version

Cap nut reinforced in upper range, with larger supporting surface (B).

3rd version

Cap nut reinforced in upper range and hard-chromed.

Identification: silver colored.

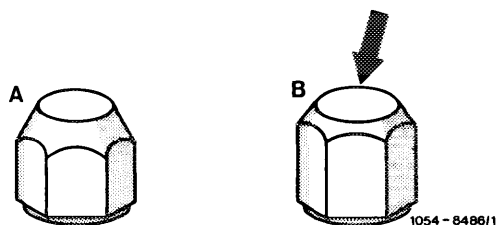

On engines with chilled cast iron camshaft and rocker arms with carbide facing, only the hard-chromed cap nut may be installed.

The hard-chromed cap nut can also be installed on engines with chilled cast iron camshafts and rocker arms with inductance-hardened and hard-chromed running surface.

Spare parts (ET) Sindelfingen will keep only hard-chromed cap nuts in stock.

Removal

1 Disconnect regulating linkage to remove cylinder head cover. Pull out locking eye of longitudinal regulating shaft (arrow).

Model 116.120

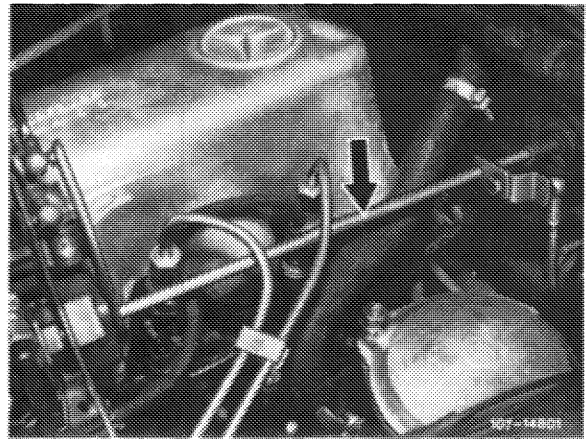

On models 116.120 and 123, pull longitudinal regulating shaft out of rubber mount in forward direction and remove in rearward direction.

On model 126.120 pull longitudinal regulating shaft out of guide lever in rearward direction and remove in forward direction.

Model 123

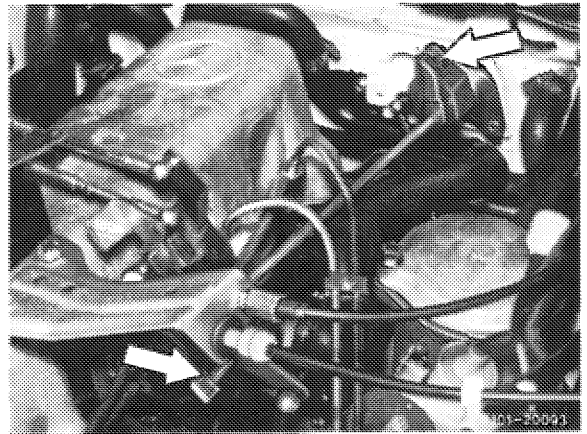

On models 123 with automatic transmission 722.303 (W 4 A 040) and 126.120, disconnect central plug for vacuum lines (71) or vacuum lines. Disconnect Bowden wire, compress black plastic clip (arrow) and pull Bowden wire out of holder in rearward direction.

Model 126.120

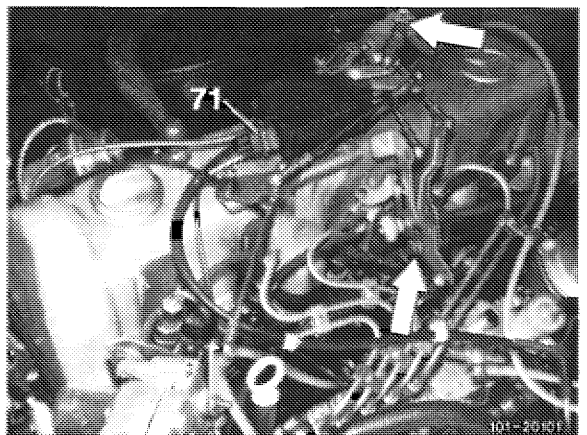

2 Remove rocker arm with rocker arm bearing brackets (05-235).

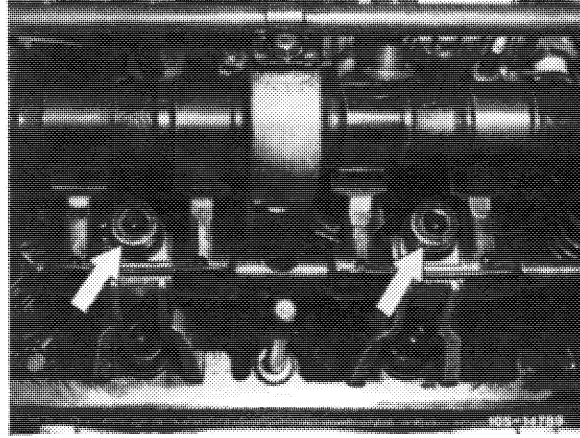

3 Set piston of respective cylinder to ignition TDC.

For this purpose, rotate crankshaft with tool combination.

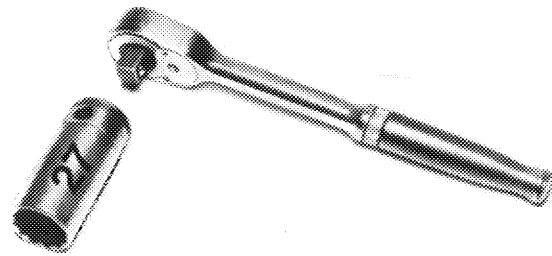

1100-6498/1

4 Place holding wrench on valve spring retainer.

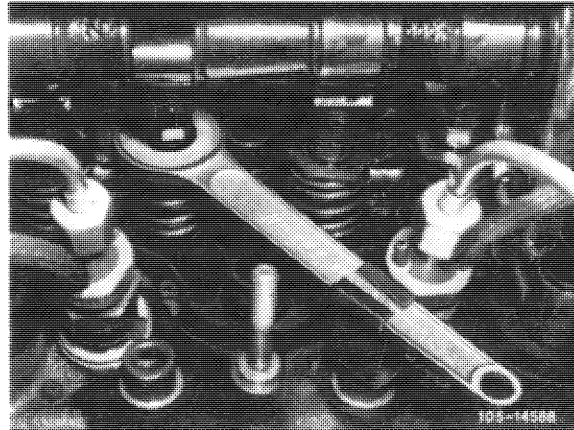

5 Unscrew cap nut (63) by means of valve adjusting wrench.

For this purpose, apply counterhold to counternut (63a) by means of second valve adjusting wrench.

6 Unscrew counternut (63a).

7 Remove valve spring retainer and valve spring.

8 Check valve spring, renew according to condition (05-260).

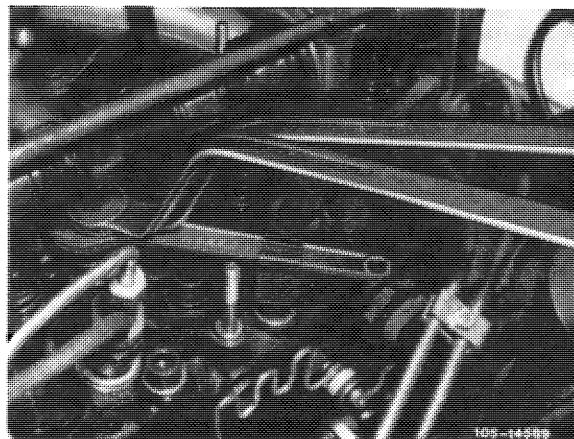

Installation

9 Insert valve spring with narrow coils toward cylinder head (color dots at top).

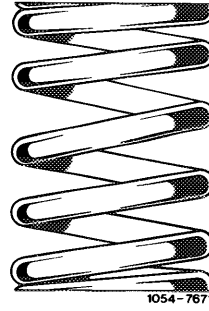

10 Mount valve spring retainer.

Lug on valve spring retainer (arrow) should be seated in groove on valve stem.

11 Screw on counternut and cap nut.

12 Install rocker arm with rocker arm bearing brackets (05-235).

13 Adjust valve clearance (05-210).

14 Mount cylinder head cover.

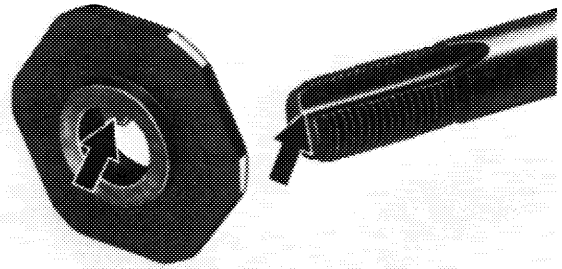

Valve timing

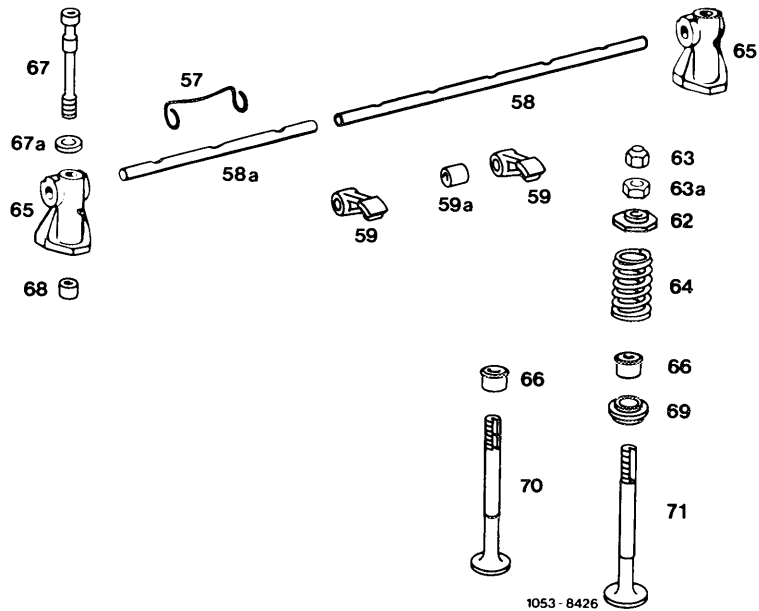

- | | |
|--------------------------------|----------------------|
| 57 Tensioning spring | 65 Bearing bracket |
| 58 Rocker arm shaft | 66 Valve shaft seals |
| 58a Rocker arm shaft | 67 Screw |
| 59 Rocker arm | 67a Washer |
| 59a Rocker arm bearing bushing | 68 Fitted sleeve |
| 62 Valve spring retainer | 69 Rotocap |
| 63 Cap nut | 70 Intake valve |
| 63a Counternut | 71 Exhaust valve |
| 64 Valve spring | |

Valve spring data

Part No.	Color code	OD mm	Wire dia. mm	Length unloaded mm	Spring force at preloaded length	When new N	Limit value N
180 053 06 20	green or purple	30.2	3.8	50.5	29.9	463–530	417
615 053 01 20 ¹⁾	yellow-yellow or purple-yellow	30.4	3.9	51.2	28.0	589	530

¹⁾ Valve spring of engine 617.950 (USA) model year 1980 with increased output and of engines 617.951/952.

Checking

- 1 Check valve springs with a valve spring tester or a spring testing scale.
- 2 Check spring force at specified length.
- 3 Renew valve springs if below limit value.

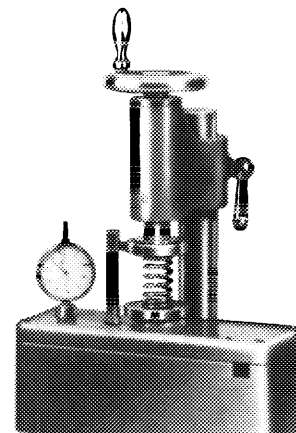

R 05/6385

cardiagn.com





05–270 Replacement of valve stem seals

Valve clearance	with engine cold (approx. 20 °C)	with engine warm (60 °C ± 15 °C)
Intake	0.10 ¹⁾	0.15 ¹⁾
Exhaust	0.35	0.40

¹⁾ 0.05 mm higher during lasting outside temperatures below –20 °C.

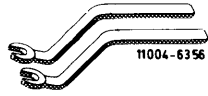
Tightening torque	Nm
Nuts for cylinder head cover	15

Special tools

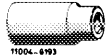
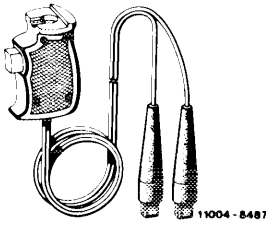
Valve adjusting wrench 14 mm (2 each)		615 589 00 01 00
Holding wrench for valve spring retainer		615 589 00 03 00
Slip gage holder, red		617 589 00 40 00
Slip gage blades	0.10 mm thick	617 589 00 23 00
	0.15 mm thick	617 589 01 23 00
	0.20 mm thick	117 589 00 23 00
	0.35 mm thick	617 589 03 23 00
	0.40 mm thick	617 589 04 23 00
Assembly mandrel for valve stem seals Intake and exhaust		617 589 00 43 00
Socket 27 mm, 1/2" square, for rotating engine		001 589 65 09 00
Contact handle for rotating engine (component of compression pressure recorder 001 589 46 21 00)		001 589 46 21 08

Conventional tool

Cylinder leak tester

e.g. made by Bosch, EFAW 210 A
made by SUN, CLT 228

Note

Valve stem seals of intake and exhaust valves are of different design and should not be mixed up. They are differently colored to show difference.

Intake valve stem seal — **black**

Exhaust valve stem seal — **green**

In addition to oil wiper lip (A), the valve stem seals also have a gas sealing lip (B).

A Oil wiper lip
B Gas sealing lip

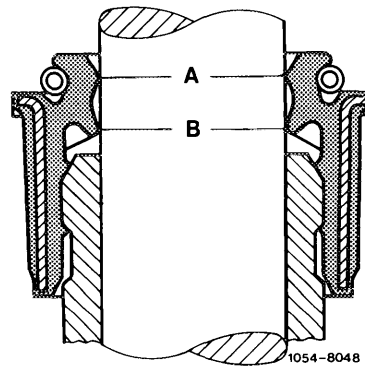

Renewing

- 1 Remove rocker arms with rocker arm brackets (05-235).
- 2 Remove valve springs (05-250).
- 3 Force off valve stem seals with a screwdriver or pull off with pliers.

Attention!

Do not damage valve stem and valve guide.

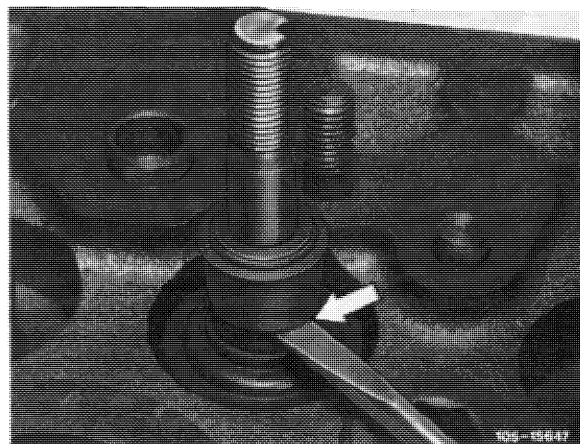

4 Lubricate new valve stem seals and mount by means of assembly mandrel.

For this purpose, be sure to place an assembly sleeve on valve stem.

5 Install valve springs (05-250).

6 Install rocker arms with rocker arm bearing brackets (05-235).

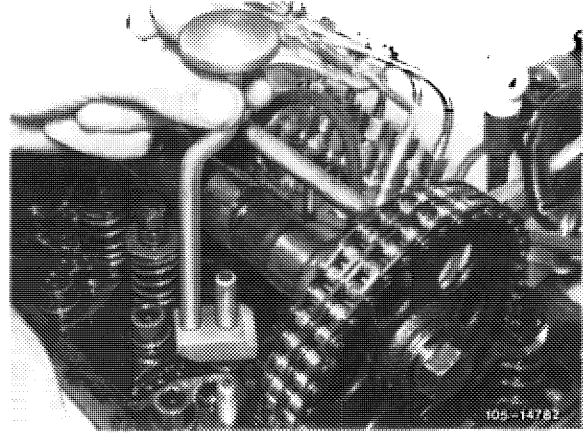

7 Adjust valve clearance (05-210).

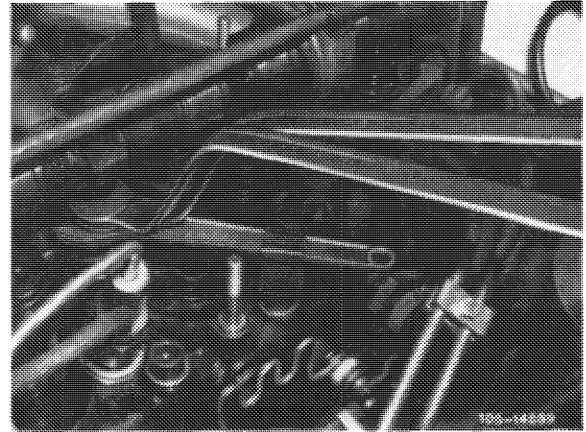

Data	Intake valve	Exhaust valve	
Valve retainer dia.	39.7–39.9	34.1–34.3	
Valve stem dia.	9.92–9.94		
Valve length	131.5		
Code number on stem end	E 617 00	A 617 00 27	
Filled-in sodium	without	with	
Valve seat plating	valve seat nitride-hardened		
Height "h" of valve retainer	when new	2.54	2.49
	limit value	2.0	2.0
Adjusting angle for machining valves	30° + 15'		
Permissible runout at valve stem and valve seat max.	0.03		
Valve shaft wear (wear limit)	0.05		
Conventional tools			
Valve cone grinder or valve cone machining tool	e.g. made by Matra-Werke GmbH D-6000 Frankfurt/Main 8 e.g. made by Hunger, D-8000 München		

Note

Exhaust valves are filled with sodium.

When scrapping valves, pay attention to safety rules. Do not melt valves filled with sodium, since there is a risk of explosion, and do not use such valves for making tools (punch, etc.), without first removing filled-in sodium.

Be careful when removing sodium from valve, since sodium mixed with water and watery solutions reacts heavily explosive, while the resulting hydrogen gas may cause fires.

Sodium from cut-up or broken-up valves can be neutralized in a mixture comprising 2 liters of spirit of alcohol and 1 liter of water put into a vessel and placed in the open air.

Valves filled with sodium can be collected and shipped for neutralizing to: Garantieprüfstelle Werk Stuttgart-Untertürkheim.

Checking and machining

1 Clean valves and check visually.

Valves with a burnt valve retainer, with insufficient height "h" of valve retainer and valves with worn out or scored valve stem should be replaced.

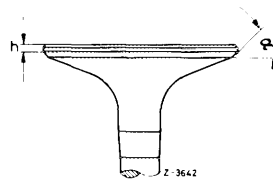

2 Measure runout on valve stem. If runout exceeds 0.03 mm, replace valve.

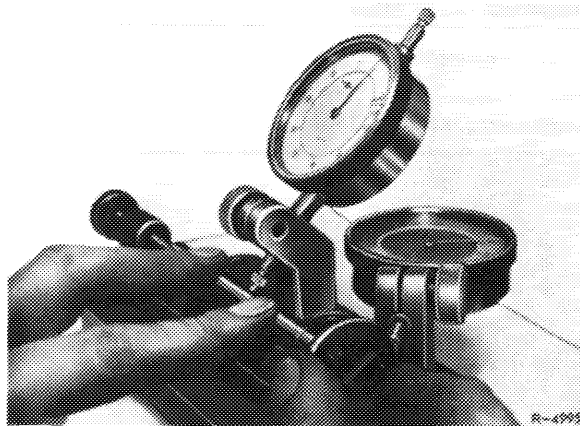

3 Machine valve seat.

Refer to operating instructions of machining tool and make sure of a 30° adjusting angle.

4 Measure runout on valve seat and height "h" of valve retainer.

As soon as the limit values are attained, replace valve.

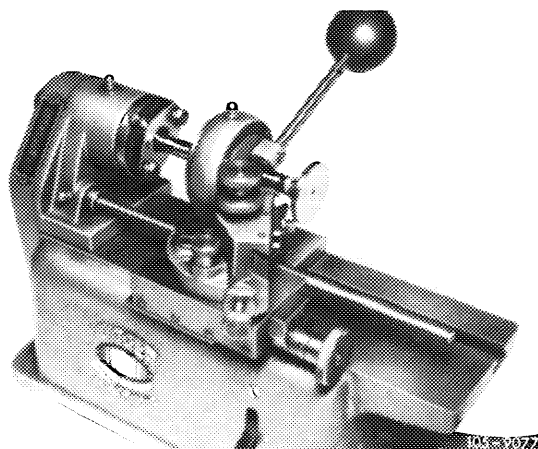

Data

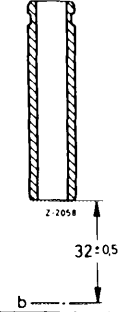
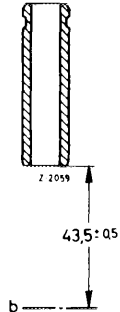
Valve guide	Part No.	Version	Color code	OD	Bore in cylinder head	Overlap	Valve guide ID	Length	Shape of valve guide
Intake	621 053 15 29 616 053 00 29 ¹⁾	Normal dimension	—	14.04 14.03	14.00 14.02	+ 0.01 up to + 0.04	10.000 10.015	61 60 ¹⁾	
	621 053 16 29 616 053 01 29 ¹⁾	Repair stage	red	14.24 14.23	14.20 14.22				
Exhaust	621 053 36 30 616 053 00 30 ¹⁾	Normal dimension	—	14.04 14.03	14.00 14.02			49.5 48.5 ¹⁾	
	621 053 37 30 616 053 01 30 ¹⁾	Repair stage	red	14.24 14.23	14.20 14.22				

Tight fit test pressure

3000—3500 N

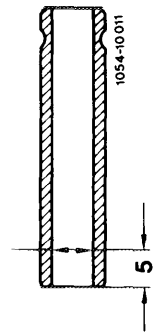

Wear limit of valve guide ID
(measuring point 5 mm above
valve guide bottom edge)

0.20

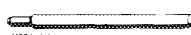

¹⁾ These valve guides are 1 mm shorter (refer to note).

Special tools¹⁾

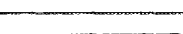
Inspection mandrel 10 mm dia.		615 589 00 21 00
Knock-out mandrel 10 mm dia.		615 589 01 15 00
Knock-in mandrel 10 mm dia.		615 589 00 15 00
Special reamer 0.99 H 7		000 589 11 53 00
Manual reamer for repair stage 14.2 dia.		115 589 00 53 00

¹⁾ Same for intake and exhaust.

Note

The valve guides 61 mm or 49.5 mm long have been replaced by valve guides 60 mm or 48.5 mm long.

In addition to their length, the valve guides are also different with regard to the shape of their grooves (arrows).

- A Valve guide = 61 mm or 49.5 mm long
- B Valve guide = 60 mm or 48.5 mm long

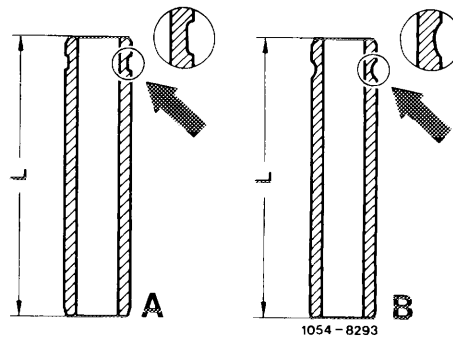

On engine 617.950 (USA) model year 1980 with increased output and on engines 617.951/952 only the shorter valve guides (B) may be installed in view of the larger valve lift.

Checking

- 1 Clean valve guide.
- 2 Measure bore by means of a plug gage or an internal measuring instrument 5 mm above bottom edge of valve guide.

If the not go end of plug gage can be easily and completely inserted, replace valve guide.

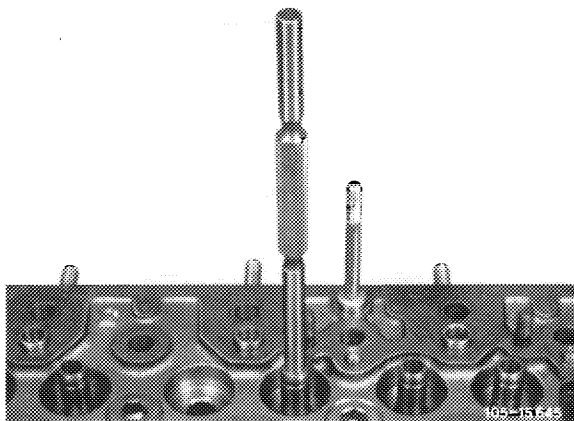

Renewing

- 3 Force-out valve guide by means of knock-out mandrel.
- 4 Check basic bore in cylinder head for score marks.

Normally dimensioned valve guides can be inserted without machining basic bore, if the specified overlap is still available (refer to item 6).

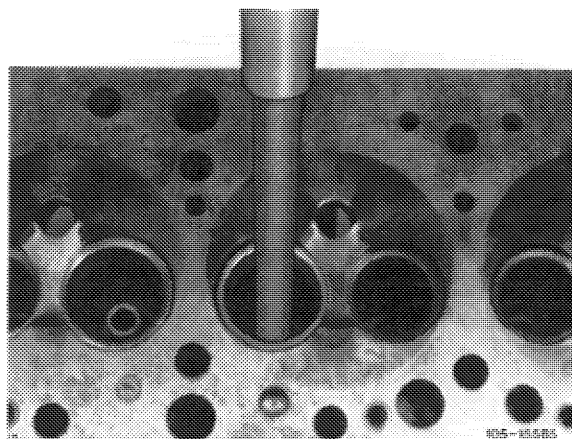

5 When using repair stage valve guides, press respective manual broach through basic bore in cylinder head.

Pressing of manual broach through basic bore can be performed on a column-type drilling machine or a hydraulic press. An important requirement is that the hand broach is inserted vertically in relation to base of cylinder head. The spindle of the column-type drilling machine or of the hydraulic press should be free of play.

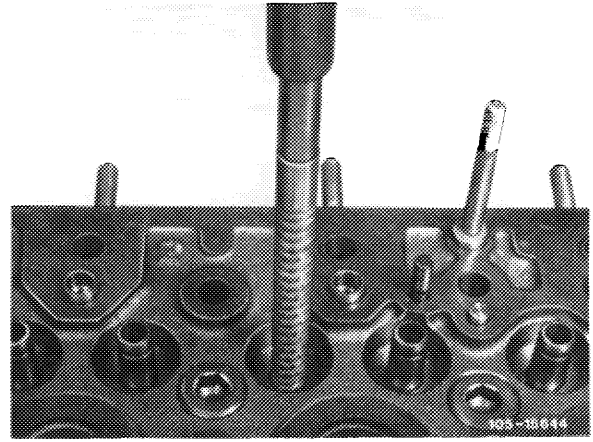

6 Coat valve guides with tallow and press-in by means of knocking-in mandrel until the dimension between cylinder head parting surface and valve guide underside named on table has been attained.

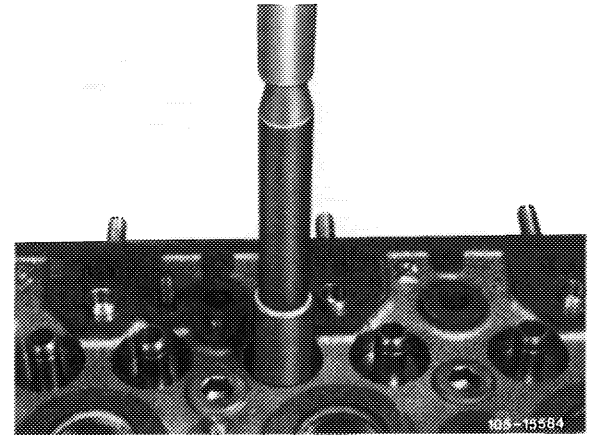

7 Check tight fit of valve guide with cylinder head cooled down only.

Test pressure of tight fit 3500 N.

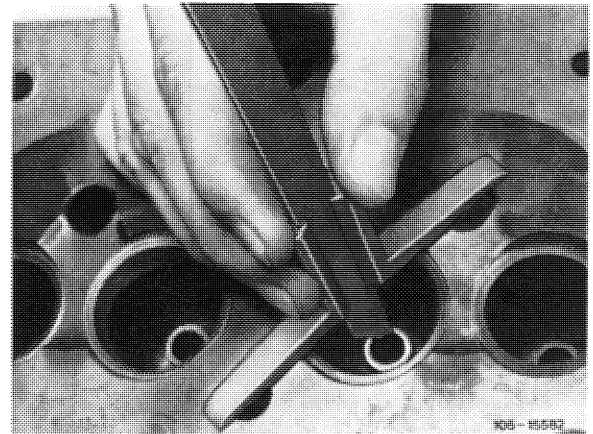

8 Check ID of valve guide with plug gage.

The go end should still slip in.

The not go end should merely touch.

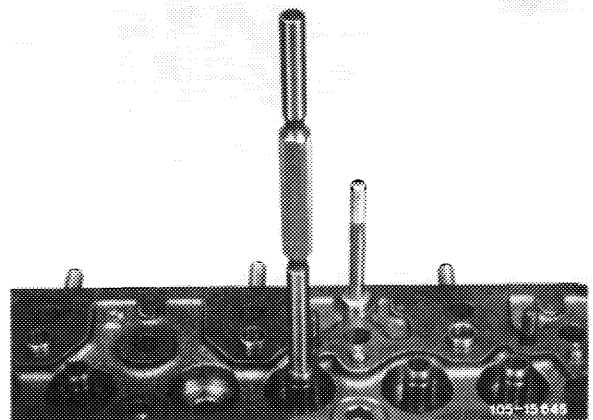

9 Slide valve into valve guide.

If the valve can be slipped in with difficulty only or not at all, ream valve guide by means of reamer.

10 Machine (refinish) valve seats (05-291).

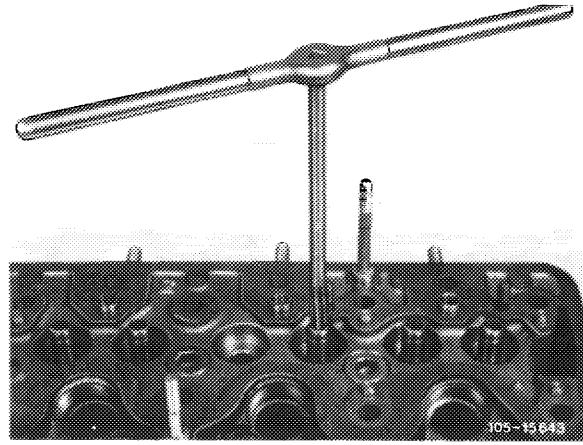

05—291 Machining valve seats

Data	Intake	Exhaust
Valve seat width b	1.3–1.6	2.5–2.9
Valve seat angle α		30°
Correction angle top β		60°
Correction angle bottom γ		60°
Permissible runout of valve seat	0.03	

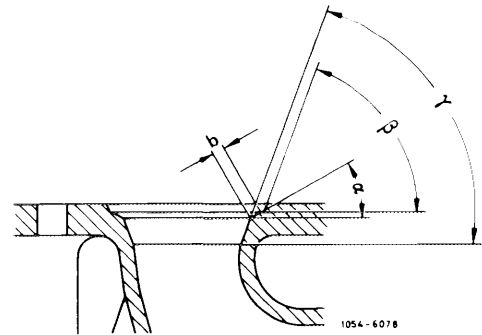

Minimum distance "a" with new valves and new valve seats

Intake	+ 0.17 to - 0.23
Exhaust	+ 0.12 to - 0.28

Maximum distance "a" with new valves and machined (refinished) valve seats

Intake	1.0
Exhaust	

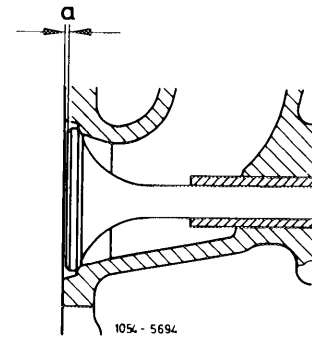

The max. distance is reduced by the same amount by which the cylinder head parting surface has been refinished.

Valve stem wear (wear limit)	0.05
------------------------------	------

Special tools

Valve adjusting wrench 14 mm
(2 each)

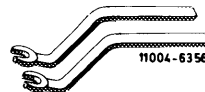

615 589 00 01 00

Holding wrench for valve
spring retainer



615 589 00 03 00

Assembly mandrel for valve stem seals
Intake and exhaust



617 589 00 43 00

Plug gage 10 mm dia. for intake and
exhaust valve guide

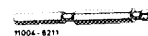

615 589 00 21 00

Conventional tools

Cylinder head clamping fixture	e.g. made by Christ, D-6801 Neckarhausen Order No. DBK 60-2
Valve seat machining tool	e.g. made by Hunger, D-8000 München Type VDNSL 1/45/30, order No. 236.03.308
Test kit for valve seats	e.g. made by Hunger, D-8000 München Order No. 216.93.300

Note

Clamp cylinder head into clamping fixture for disassembly and machining.

Machine valve seats with valve machining tool, with valve seat grinding machine or with valve seat milling cutter.

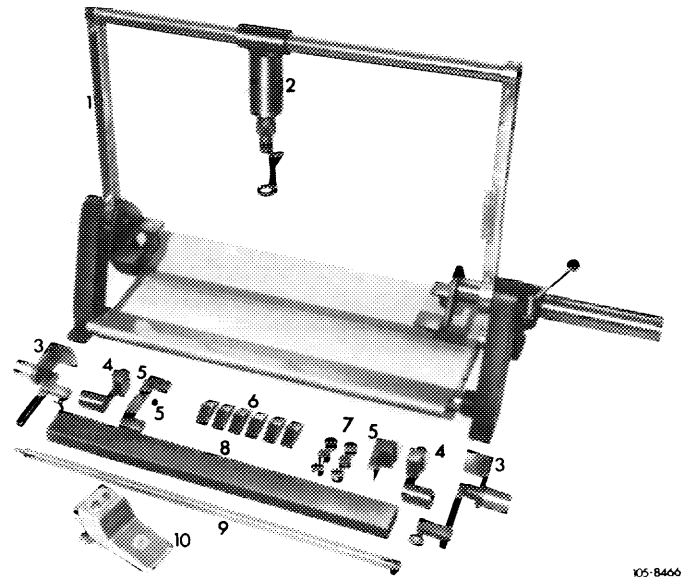

105-8460

Machining valve seats

1 Check valve guides and replace, if required (05-285).

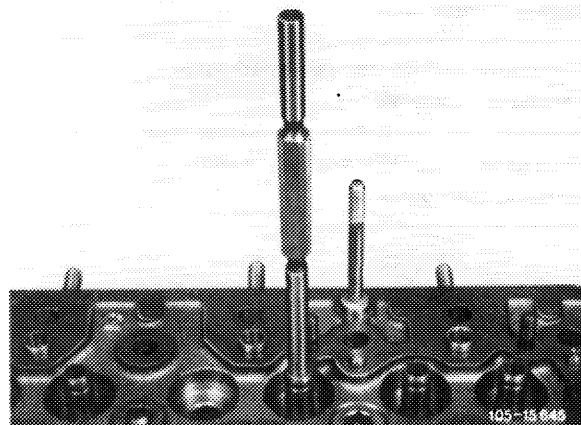

105-15 642

2 Machine valve seat (30°) (refer to operating instructions of tool manufacturer).

Attention!

Release pilot (013) only after runout of valve seat has been checked.

3 Measure valve seat width b and correct below to 60° , if required.

If required, also correct clearance (β) to 60° .

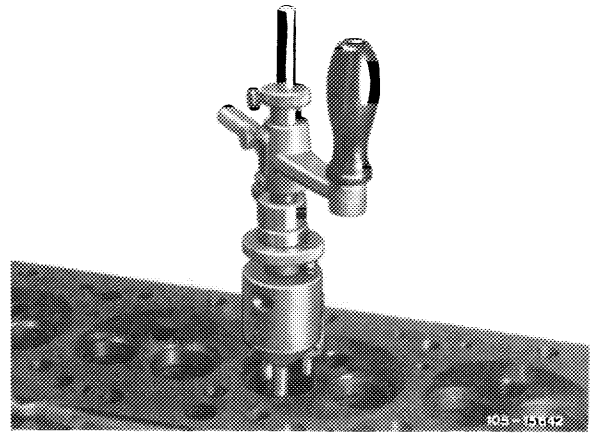

4 Check runout of valve seat.

For this purpose, slip test sleeve (017) with dial gage holder (016) and dial gage on pilot (013) and rotate test sleeve. The permissible runout of 0.03 mm should then not be exceeded.

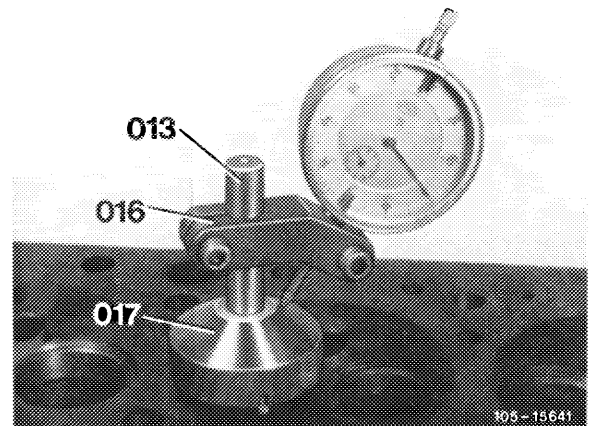

- 013 Pilot
- 016 Dial gage holder
- 017 Test sleeve

5 Introduce new valve and measure max. distance a .

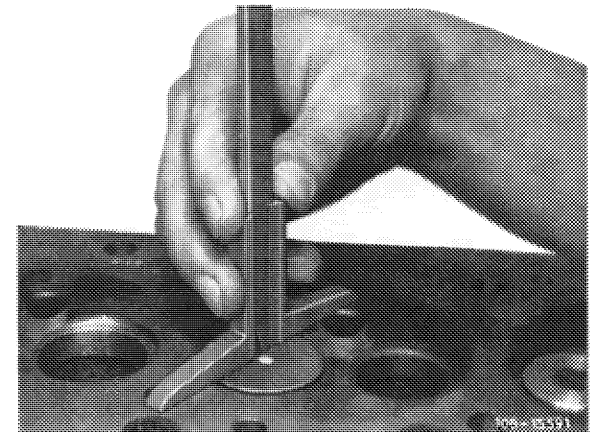

Tightening torques	Nm
Nuts for cylinder head cover	15
Closing plug for chain tensioner	90

Special tool

Socket 27 mm, 1/2" square, for rotating engine

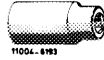

001 589 65 09 00

Note

This engine is provided with a hydraulic detent chain tensioner without valve.

The pressure required for tensioning timing chain comprises the force of the compression spring (77) and the oil pressure in chain tensioner, in dependence of engine oil pressure.

In the event of shock-type loads, a throttle bore (a) of 1.5 mm dia. in oil feed and a throttle bore (b) of 1.3 mm dia. in thrust bolt prevents fast flowing-off of oil.

- | | |
|-----------------------|-----------------------------|
| 35 Cylinder head | 83 Chain tensioner housing |
| 75 Closing plug | 84 Gasket |
| 76 Sealing ring | 85 Tensioning rail |
| 77 Compression spring | a Throttle bore 1.5 mm dia. |
| 78 Detent spring | b Throttle bore 1.3 mm dia. |
| 79 Pressure bolt | |

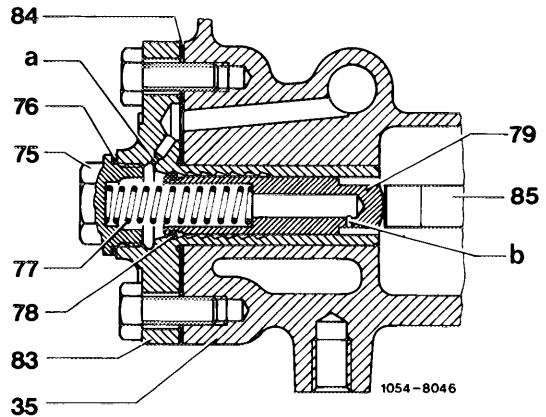

The chain tensioner housing (83) holds a detent and on pressure bolt (79) a detent spring (78).

The pressure bolt moves forward from detent to detent in accordance with elongation of chain. Travel to the rear is limited by detents. As a result, the pressure bolt cannot be pushed back when the engine is stopped. Any jumping of the loose timing chain or any chain noise when the engine is started is therefore eliminated.

The oil required for operation of chain tensioner is provided via first camshaft bearing, the cylinder head bolt bore at front right and a transverse duct in cylinder head.

During assembly and test jobs on chain drive, the chain tensioner need not be removed. In such cases it will be enough to remove the compression spring (77) (item 3, 4, 11 and 12).

If, on the other hand, parts of the chain drive are renewed, remove chain tensioner and set pressure bolt into assembly position.

When installing a new chain tensioner, also pay attention to assembly position (A). If the pressure bolt is too far forward (in last detent), the timing chain is extensively tensioned or the detent spring (78) is stuck in detent.

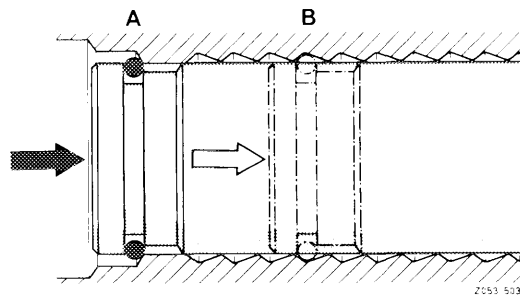

A Chain tensioner in assembly position
B Chain tensioner in operating position

On engine 617.950 starting with engine end No. 006223, the chain tensioner gasket (B) has been installed for reasons of standardization with engines 615, 616 and 617.912. On engines 617.951/952 from start of series.

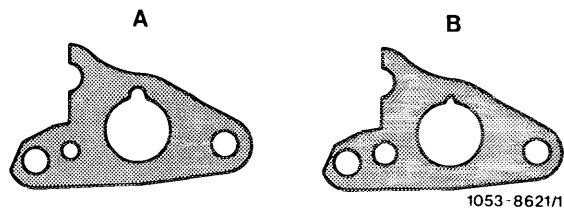

A 1st version
B 2nd version

Removal

- 1 Drain coolant.
- 2 On engines with EGR (USA), remove pipe line between EGR valve and exhaust manifold (arrow). For this purpose, unscrew shielding plate (10).

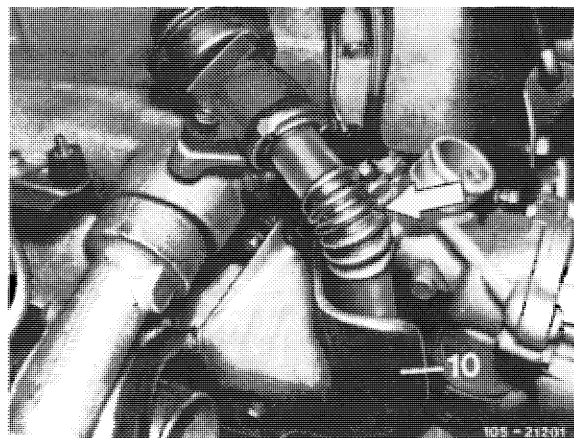

3 On model 123 with level control, unscrew line holder on thermostat housing (arrow).

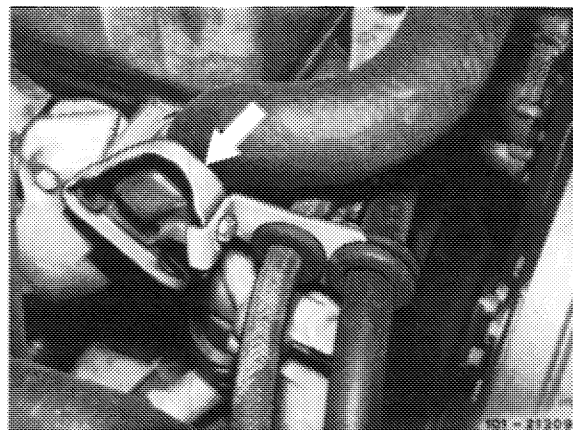

4 Remove thermostat housing.

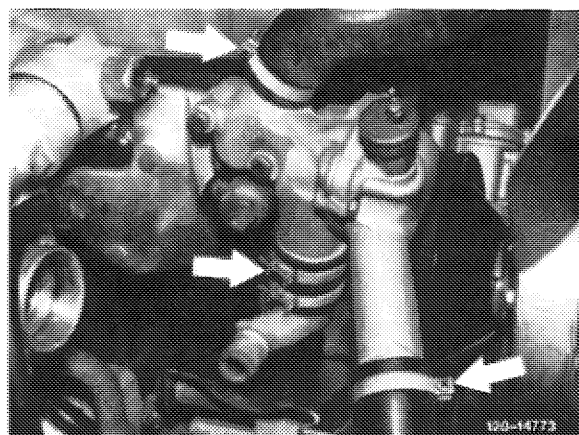

5 Unscrew closing plug (75) of chain tensioner.

Attention!

Closing plug is under pressure of compression spring (77).

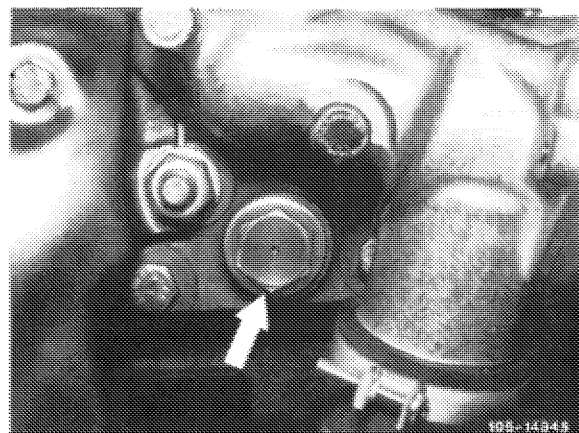

6 Remove compression spring (77).

7 Unscrew chain tensioner housing and pull out.

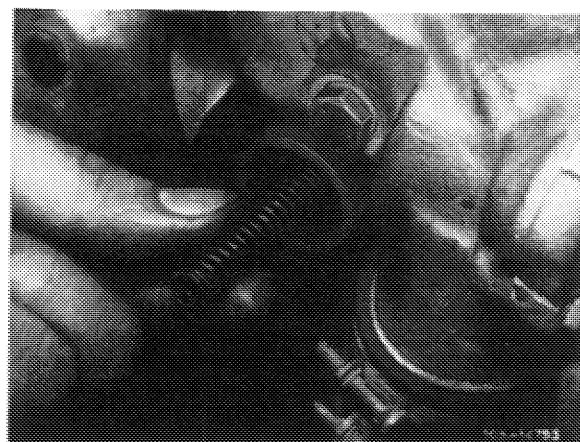

8 Pull out pressure bolt (79) in forward direction.

9 Thoroughly clean all parts.

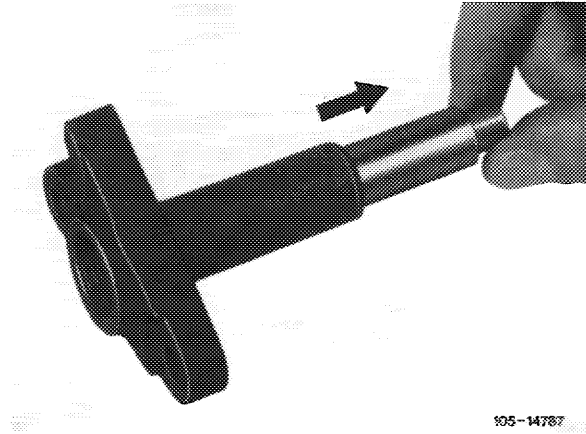

105-14787

Installation

Note: Prior to installing chain tensioner, the chain drive must be completely mounted.

10 Rotate engine with tool combination in direction of rotation once, so that timing chain is under tension.

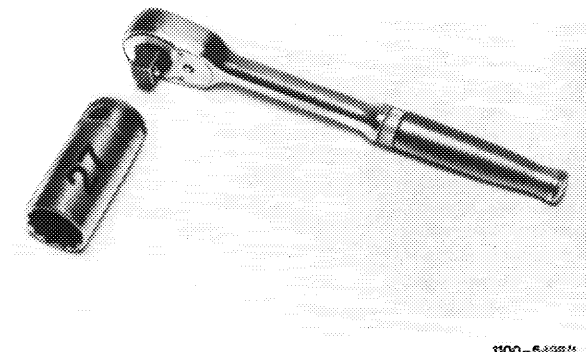

100-6438/1

11 Insert chain tensioner housing (83) with new gasket (84) and tighten.

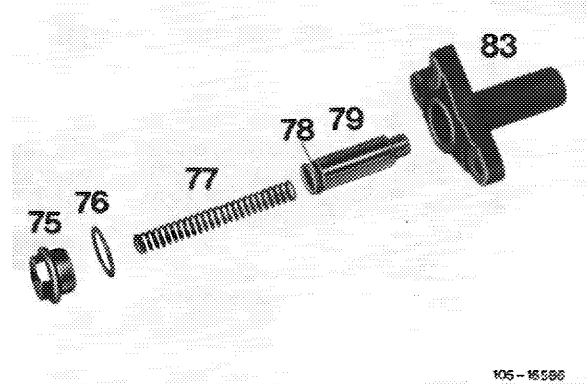

- 75 Closing plug
- 76 Sealing ring
- 77 Compression spring
- 78 Detent spring
- 79 Pressure bolt
- 83 Chain tensioner housing

105-18586

12 Place pressure bolt (79) on assembly detent.

13 Insert compression spring (77).

14 Position closing plug (75) with new sealing ring (76) and tighten to 90 Nm.

15 For further installation proceed vice versa to removal.

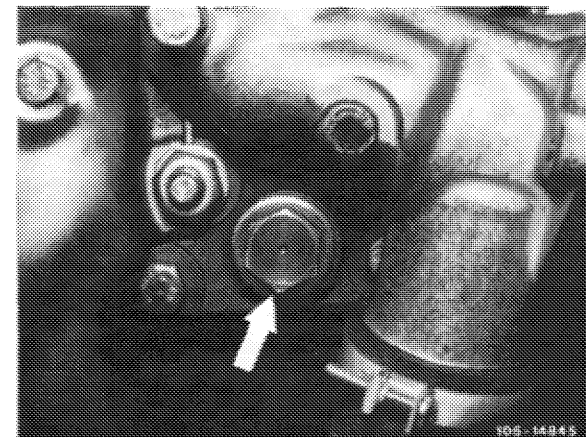

105-14845

Tightening torques

Nm

Nuts for cylinder head cover

15

Closing plug for chain tensioner

90

Special tool

Socket 27 mm, 1/2" square,
for rotating engine

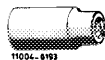

001 589 65 09 00

Note

The split timing chain with connecting link is used for repairs.

If only an endless timing chain is available, the chain can be opened prior to installation (refer to item 3).

During an engine overhaul, always install an endless timing chain.

Check sprockets for score marks and pitting.

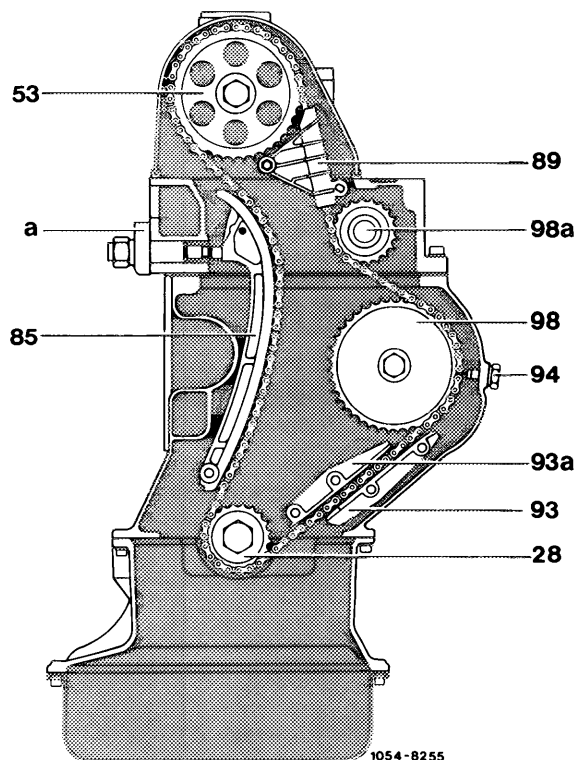

- 28 Crankshaft sprocket
- 53 Camshaft sprocket
- 85 Tensioning rail
- 89 Slide rail
- 93 Outer slide rail
- 93a Inner slide rail
- 94 Chain locking screw
- 98 Injection timer
- 98a Guide wheel
- a Chain tensioner

1054-8255

Renewal

- 1 Unscrew pencil element glow plugs.
- 2 Disconnect regulating linkage to remove cylinder head cover. Pull out locking eye of longitudinal regulating shaft (arrow).

Model 116.120

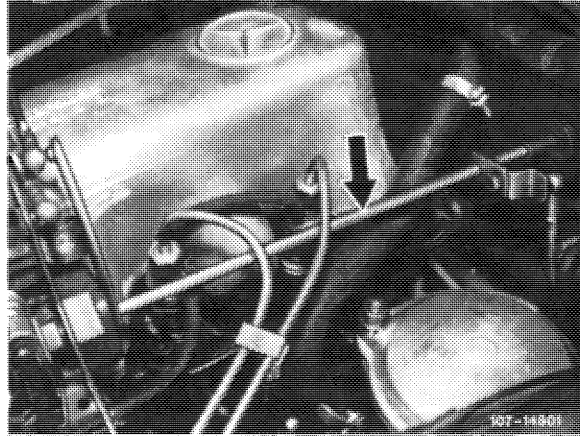

On models 116.120 and 123, pull longitudinal regulating shaft out of rubber mount in forward direction and remove in rearward direction.

On model 126.120, pull longitudinal regulating shaft out of guide lever in rearward direction and remove in forward direction.

Model 123

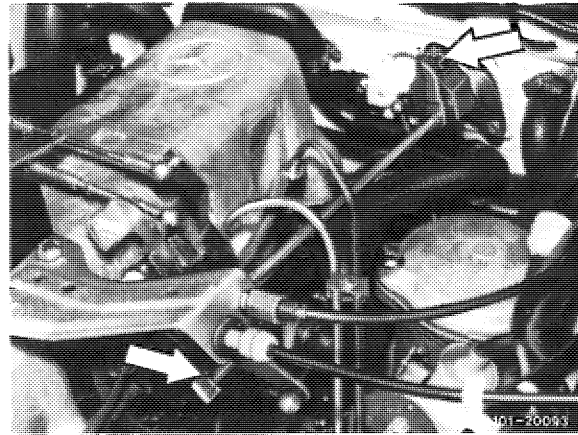

On models 123 with automatic transmission 722.303 (W 4 A 040) and 126.120, pull off central plug for vacuum lines (71) or vacuum lines. Disconnect Bowden wire, compress black plastic clip (arrow) and pull Bowden wire out of holder in rearward direction.

Model 126.120

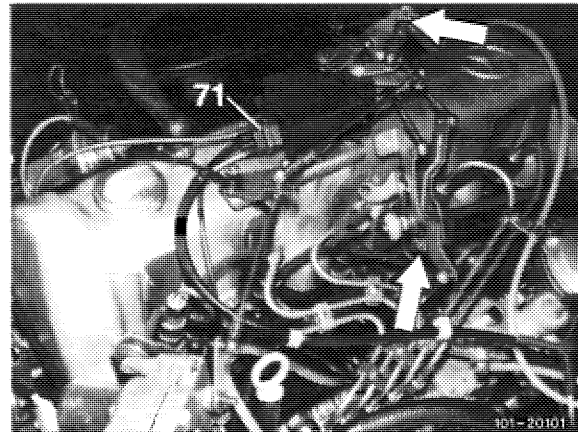

- 3 Remove chain tensioner (05–310).
- 4 Cover chain box with a rag and grind off both chain bolts on one link of timing chain.
- 5 Connect new timing chain to old timing chain, while simultaneously pushing out opened link (Fig. item 7).

6 Turn crankshaft with tool combination slowly in direction of rotation of engine, while simultaneously pulling up the old timing chain until the connecting link comes to rest at uppermost position of camshaft sprocket.

Attention!

Timing chain should be in mesh with camshaft and crankshaft sprocket during rotation.

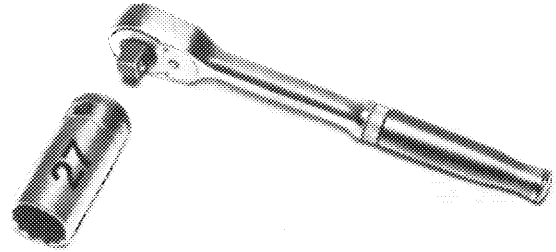

1100-6193/1

7 Disconnect old timing chain and connect the ends of the new timing chain by means of a connecting link. Mount lock washers.

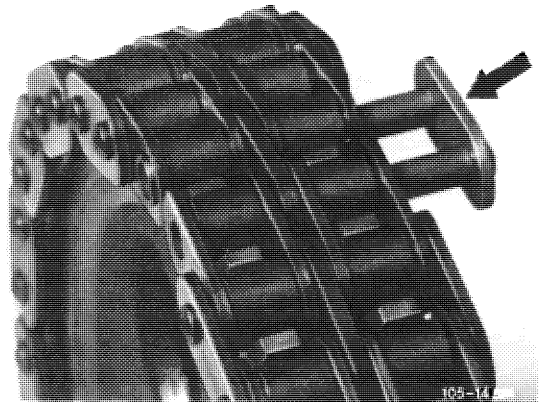

Note: Insert new connecting link from the rear so that the lock washers can be seen from the front (arrows).

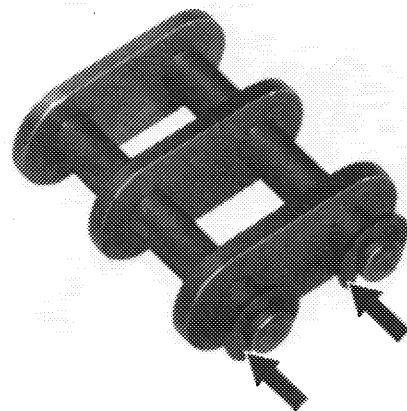

105-14 313

8 Rotate crankshaft and check adjusting marks at TDC position of engine.

Note: If the adjusting marks are not in alignment, check timing of camshaft (05-215) and begin of delivery of injection pump (07.1-110).

9 Install chain tensioner (05-310).



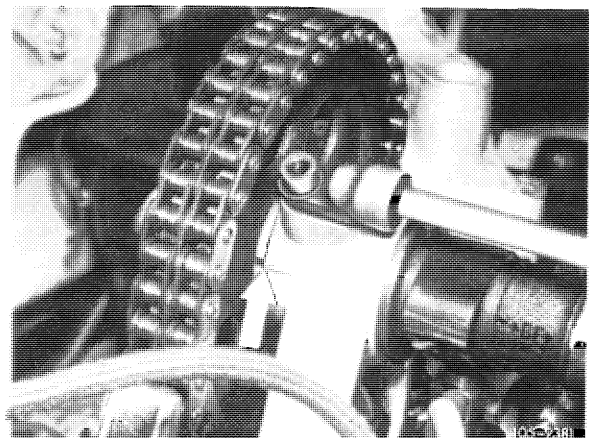



10 Screw in pencil-type glow plugs and mount cylinder head cover.

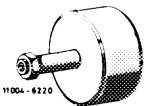

05-330 Removal and installation of tensioning rail

Tightening torques	Nm
Nuts for cylinder head cover	15
Closing plug for chain tensioner	90
Necked-down screw for camshaft sprocket	80

Special tools

Impact puller for bearing bolt (basic unit)		116 589 20 33 00
Threaded bolt M 8, 150 mm long for impact puller		616 589 00 34 00
Threaded bolt M 6, 50 mm long for impact puller		116 589 01 34 00
Puller for bearing bolt		115 589 20 33 00
Threaded bolt M 8, 30 mm long for puller		115 589 00 34 00
Screwdriver (Allen wrench) with tommy handle for hex. socket screws 6 mm, 440 mm long		116 589 03 07 00
Socket 27 mm, 1/2" square, for rotating engine		001 589 65 09 00

Note

To avoid mixups with tensioning rail of 4-cylinder gasoline engines, the tensioning rails have been marked.

The tensioning rail of the 4-cylinder gasoline engine is wider at upper end (B) and has no bore in upper part (arrow).

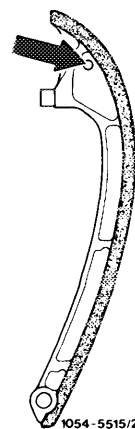

On the other hand, the tensioning rail of this engine is pointed at upper end (A) and has an 8 mm bore in upper part.

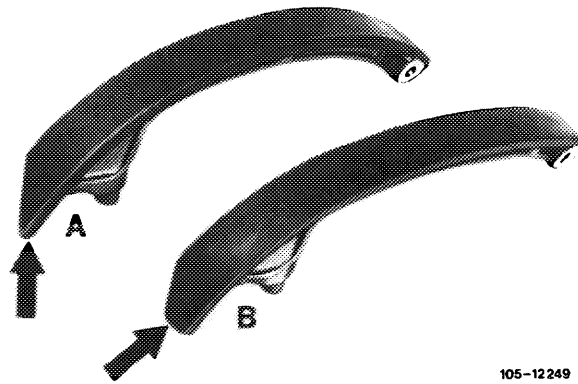

A Tensioning rail diesel engines
B Tensioning rail gasoline engines

105-12249

In addition, a lug has been cast-on to lower end of tensioning rail to avoid confusion.

The lug on the tensioning rail of this engine is located in direction of cylinder 1 and on tensioning rail of 4-cylinder gasoline engine in direction of balancing disk.

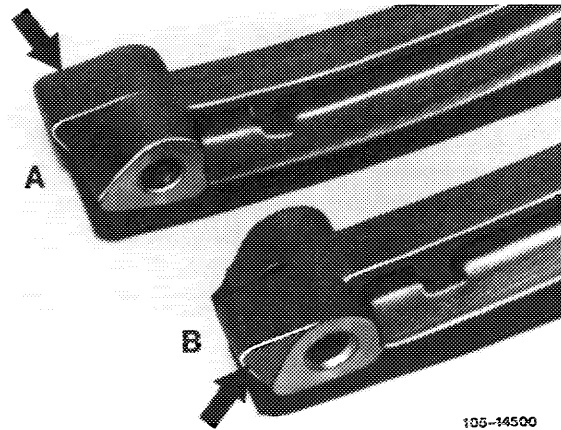

A Tensioning rail diesel engines
B Tensioning rail gasoline engines

105-14500

In the periods June — August and September — October 1980 a tensioning rail made by another manufacturer has been installed.

This tensioning rail is not available as a spare part.

Start of series

Model	Chassis end No.
116.120	026904—028634
123.193	000001—000031 000166—000384
126.120	000001—000100 000955—001657

Removal

- 1 Remove radiator and fan.
- 2 Disconnect regulating linkage to remove cylinder head cover. Pull out locking eye of longitudinal regulating shaft (arrow).

Model 116.120

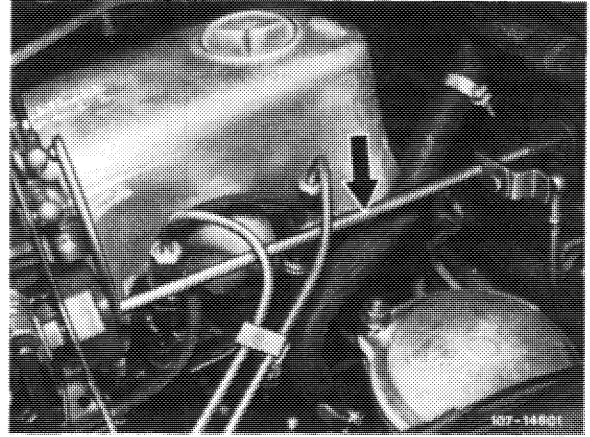

On models 116.120 and 123, pull longitudinal regulating shaft out of rubber mount in forward direction and remove in rearward direction.

On model 126.120, pull longitudinal regulating shaft out of guide lever in rearward direction and remove in forward direction.

Model 123

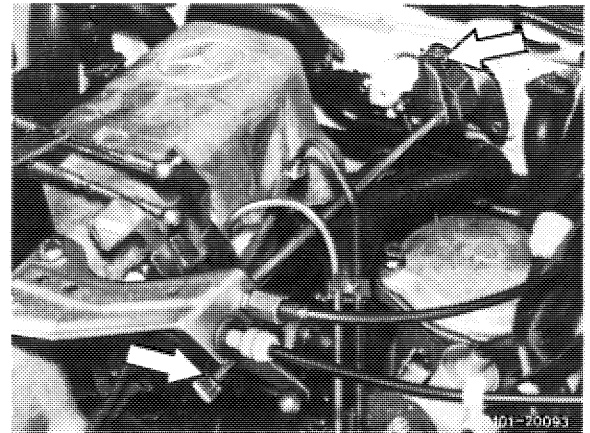

On models 123 with automatic transmission 722.303 (W 4 A 040) and 126.120, pull off central plug for vacuum lines (71) or vacuum lines. Disconnect Bowden wire, compress black plastic clip (arrow) and pull Bowden wire out of holder in rearward direction.

Model 126.120

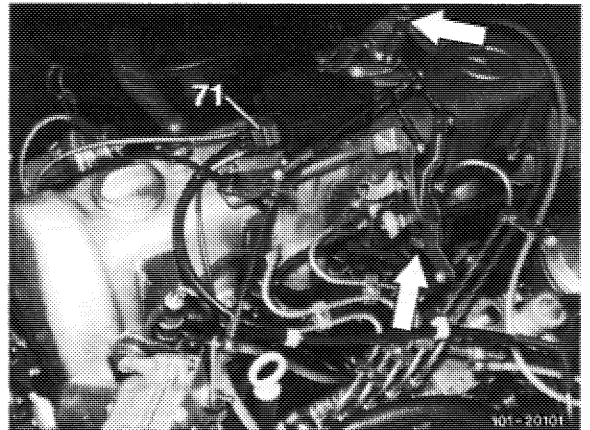

- 3 Remove pulley and vibration damper (03-340).
- 4 Rotate crankshaft with tool combination until recess in balancing disk is in front of bearing bolt of tensioning rail (Fig. item 12).

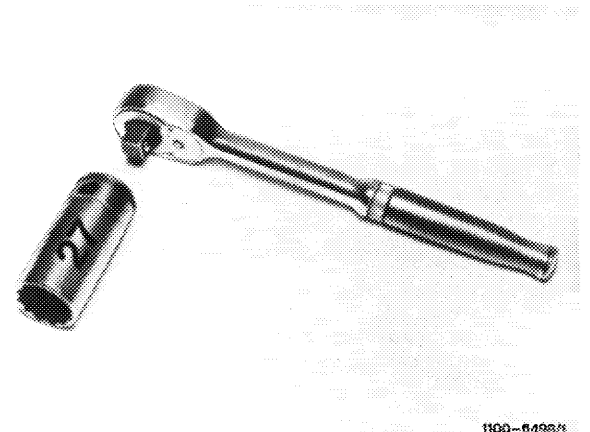

5 On engines with EGR (USA), remove pipe line between EGR valve and exhaust manifold (arrow). For this purpose, unscrew shielding plate (10).

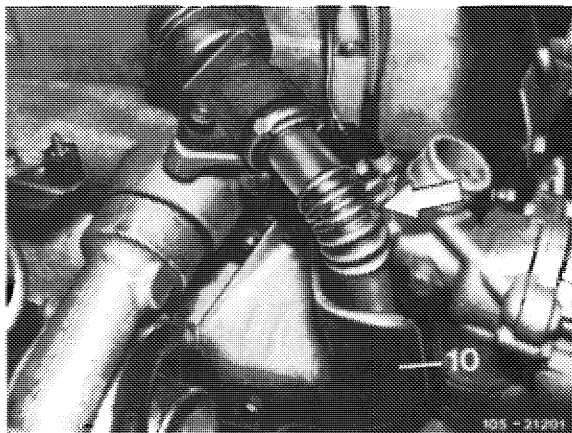

6 On model 123 with level control, unscrew line holder on thermostat housing (arrow).

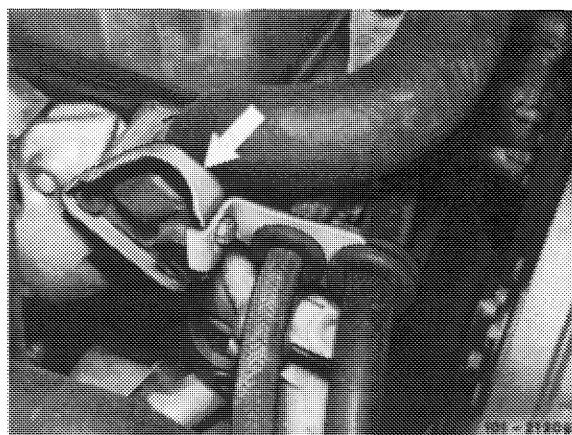

7 Unscrew closing plug of chain tensioner.

Attention!
The closing plug is under pressure of compression spring.

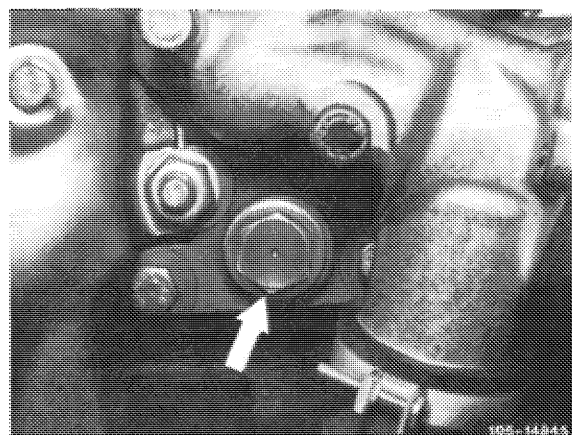

8 Remove compression spring in chain tensioner.

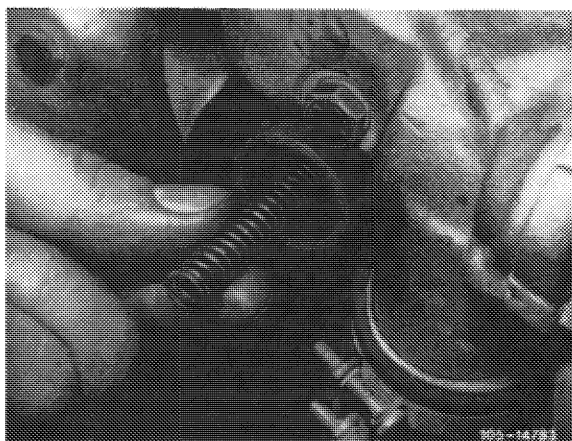

9 Mark camshaft sprocket and timing chain in relation to each other.

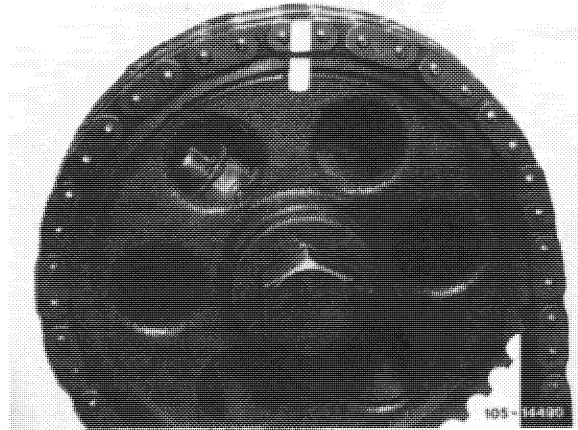

10 Remove slide rail in cylinder head.

Pull out bearing bolt by means of impact puller.

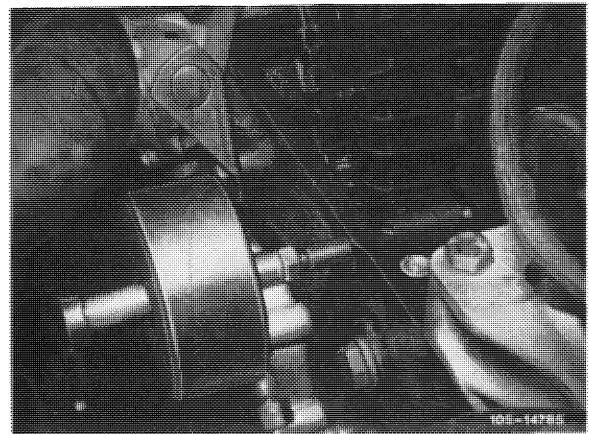
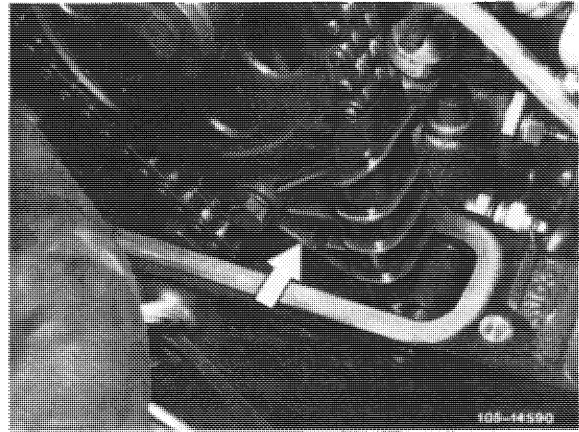

11 Remove camshaft sprocket.

For loosening necked-down screw, apply counterhold to camshaft sprocket by means of a screwdriver or steel bolt.

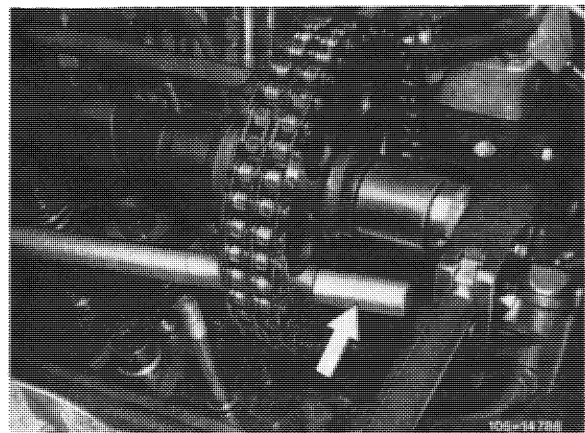

12 Knock out bearing bolt by means of impact puller.

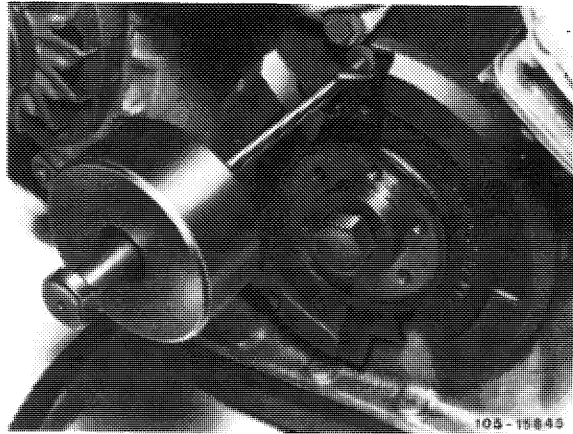

Attention!

If bearing bolt is stuck to the extent that it cannot be knocked out with impact puller, use puller part No. 115 589 20 33 00.

For this purpose, remove balancing disk and provide puller with a recess.

The recess is necessary to position the puller with cylinder crankcase cover installed.

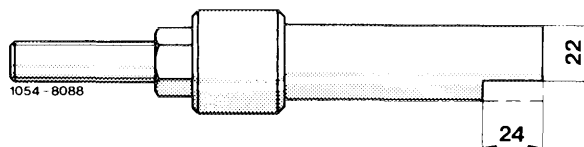
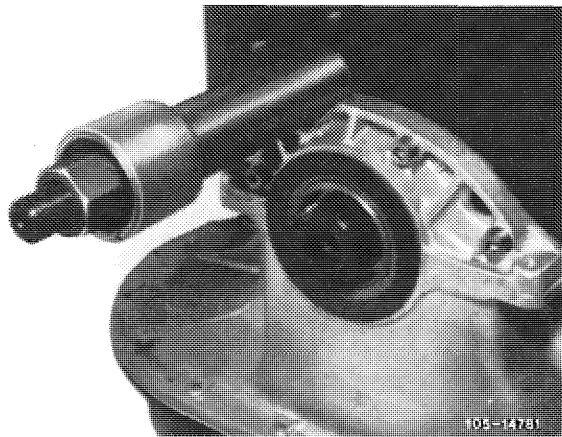

13 Remove tensioning rail in upward direction.

14 Unscrew cyl. head screw M 8 in chain box adjacent to pressure bolt of chain tensioner by means of screwdriver (Allen wrench) with tommy handle.

15 Pull out pressure bolt of chain tensioner in inward direction (arrow).

16 Clean bearing bolt.

17 Renew badly worn tensioning rails and bearing bolts.

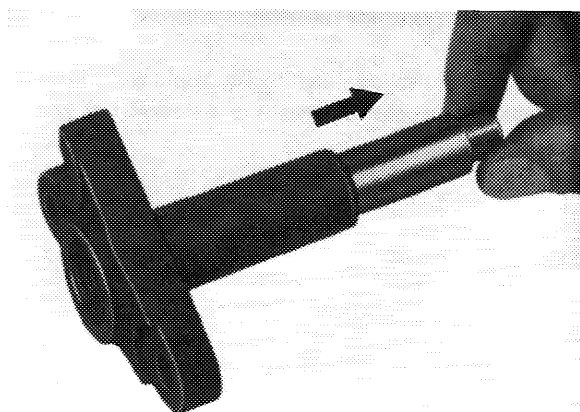

Installation

- 18 Coat bearing bolt on flange with sealing compound.
- 19 Position tensioning rail and knock in bearing bolt by means of impact puller.
- 20 Place camshaft sprocket with timing chain on camshaft, while paying attention to color marks.

21 Position necked-down screw for fastening camshaft sprocket and tighten to 80 Nm. For this purpose, apply counterhold to camshaft sprocket by means of a screwdriver or a steel bolt.

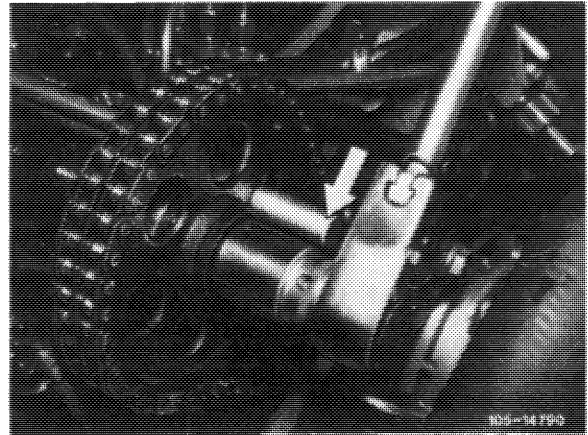

22 Place pressure bolt of chain tensioner on assembly detent.

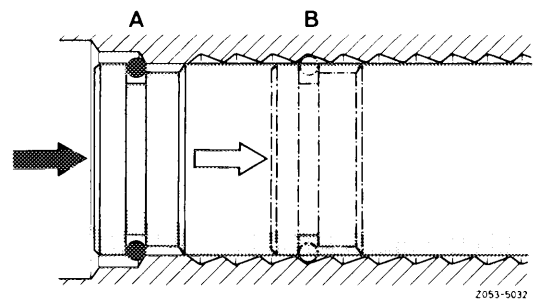

- A Chain tensioner in assembly position
B Chain tensioner in operating position

- 23 Insert compression spring.
- 24 Position closing plug of chain tensioner with new sealing ring and tighten to 90 Nm.

Make sure that pressure bolt is seated on thrust piece of tensioning rail.

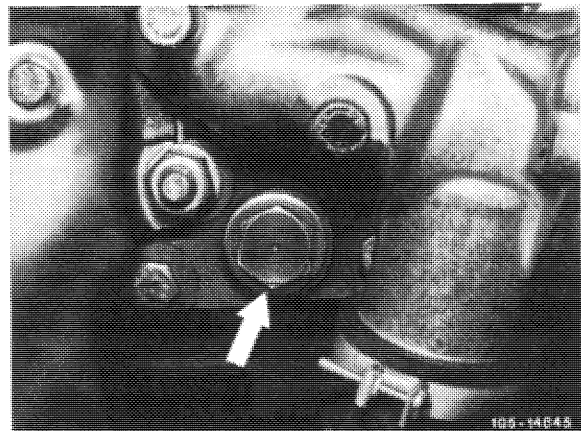

- 25 Screw in cyl. head bolt M 8 by means of screwdriver (Allen wrench) with tommy handle.
- 26 For further installation proceed vice versa to removal.



05-340 Removal and installation of slide rails

Tightening torques	Nm
Nuts for cylinder head cover	15
Necked-down screw for camshaft sprocket	80
Fastening screw for injection timer	40
Closing plug for chain tensioner	90

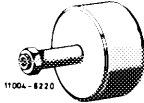
Special tools

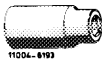
Impact puller for bearing bolt (basic unit)		116 589 20 33 00
Threaded bolt M 6, 150 mm long for impact puller		116 589 02 34 00
Threaded bolt M 6, 50 mm long for impact puller		116 589 01 34 00
Socket 27 mm, 1/2" square, for rotating engine		001 589 65 09 00

Remove slide rail (89)

1 Disconnect regulating linkage to remove cylinder head cover. Pull out locking eye of longitudinal regulating shaft (arrow).

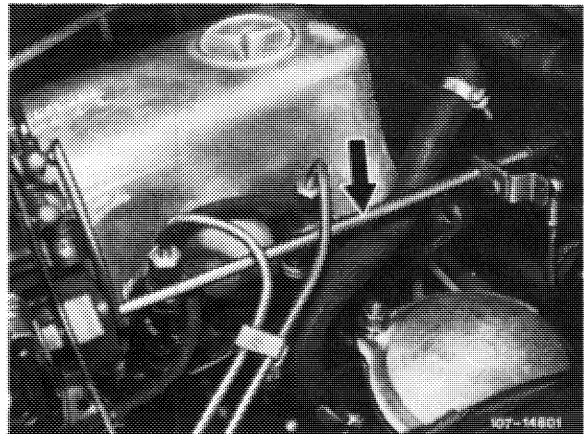

Model 116.120

On models 116.120 and 123, pull longitudinal regulating shaft out of rubber mount in forward direction and remove in rearward direction.

On model 126.120, pull longitudinal regulating shaft out of guide lever in rearward direction and remove in forward direction.

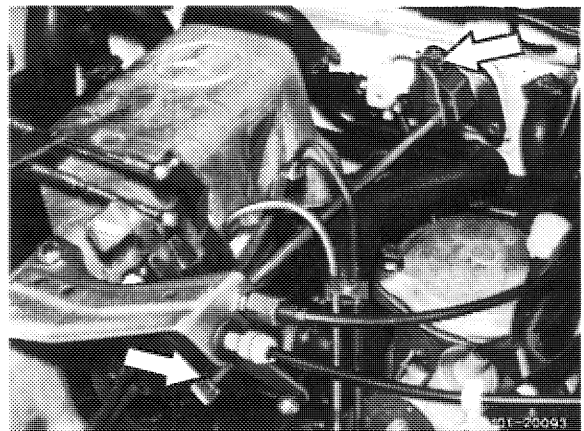

Model 123

On models 123 with automatic transmission 722.303 (W 4 A 040) and 126.120, pull off central plug for vacuum lines (71) or vacuum lines. Disconnect Bowden wire, compress black plastic clip (arrow) and pull Bowden wire out of holder in rearward direction.

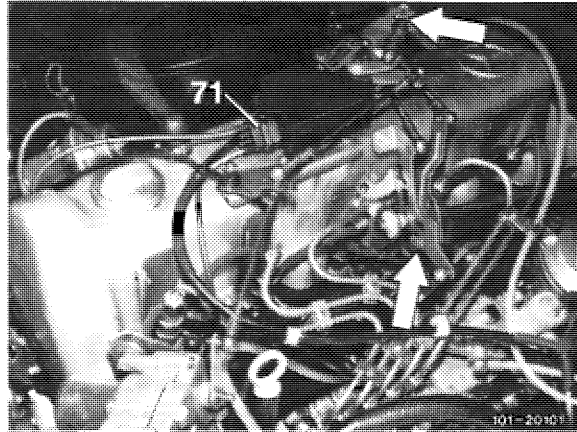

Model 126.120

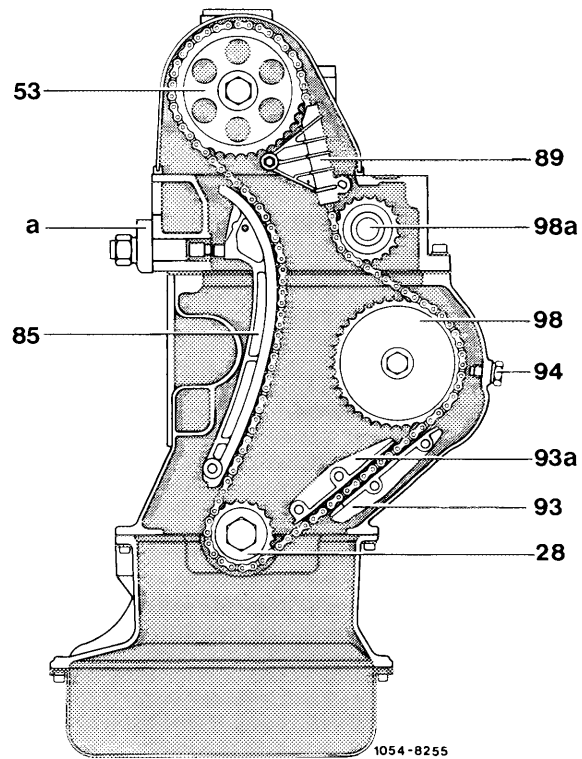

- 28 Crankshaft sprocket
- 53 Camshaft sprocket
- 85 Tensioning rail
- 89 Slide rail
- 93 Outer slide rail
- 93a Inner slide rail
- 94 Chain locking screw
- 98 Injection timer
- 98a Guide wheel
- a Chain tensioner

2 On model 123 with level control, remove pressure oil pump with connected lines and put aside.

3 Remove screw (arrow).

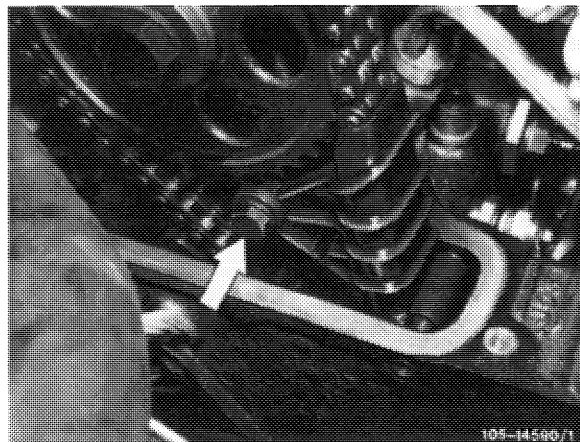

- 4 Pull out bearing bolt with impact puller.
- 5 Remove slide rail in upward direction.

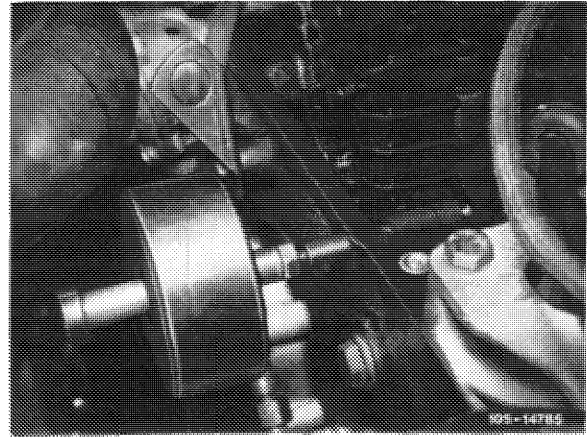

Installation

- 6 Coat bearing bolt on flange with sealing compound.
- 7 Position slide rail and knock in bearing bolt by means of impact puller.
- 8 Screw-in screw.
- 9 Mount cylinder head cover.

Removing inner slide rail (93a)

- 1 Remove radiator and fan.
- 2 Remove vacuum pump (42–610).
- 3 Remove pulley, vibration damper and balancing disk (03–340).
- 4 Remove cylinder head cover (refer to Remove slide rail [89]).
- 5 Unscrew closing plug (1) and put adjusting pointer with TDC transmitter aside.
- 6 Remove injection timer (07.1–210).

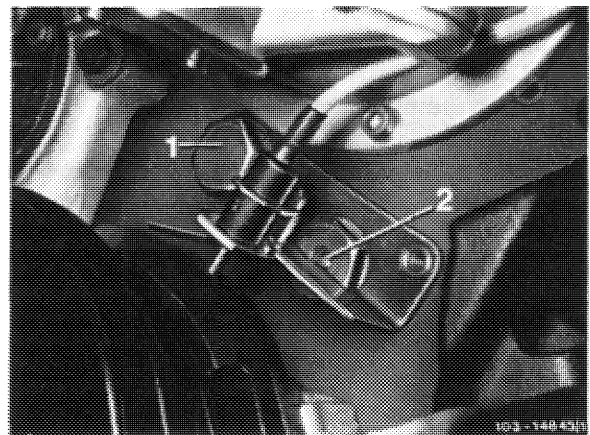

7 Unscrew closing plug with upper bearing bolt (2) and pull out.

8 Pull out lower bearing bolt by means of impact puller.

9 Remove slide rail in upward direction.

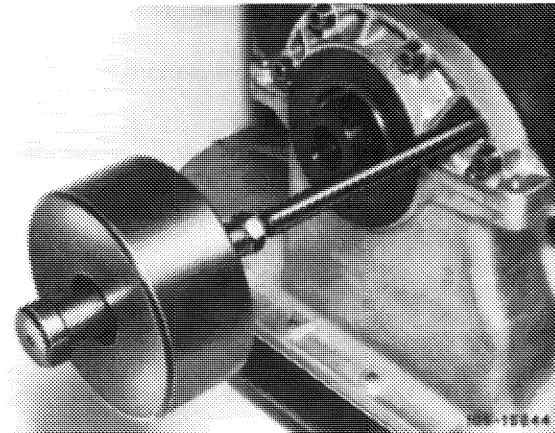

Installation

10 Coat lower bearing bolt on flange with sealing compound.

11 Position slide rail and knock in lower bearing bolt by means of impact puller.

Attention!

The locating lug of the slide rail should rest in locating groove of bearing bolt (arrow).

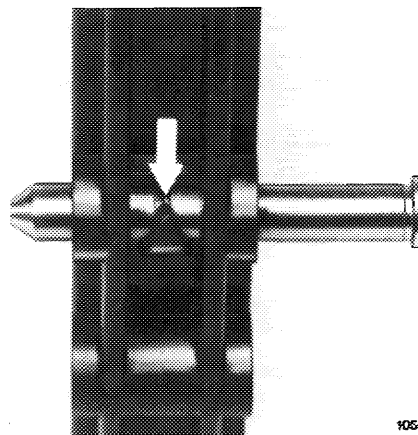

12 Position closing plug and screw-in.

13 Install injection timer (07.1-210).

14 Position adjusting pointer with TDC transmitter and screw on.

15 Attach vacuum pump (42-610).

16 Install pulley, vibration damper and balancing disk (03-340).

17 Install radiator and fan.

18 Mount cylinder head cover.

Removing outer slide rail (93)

- 1 Remove radiator and fan.
- 2 Remove vacuum pump (42–610).
- 3 Remove injection timer (07.1–210).
- 4 Remove cylinder head cover (refer to Remove slide rail [89]).
- 5 Pull out both bearing bolts of slide rail by means of impact puller.
- 6 Remove slide rail in upward direction.

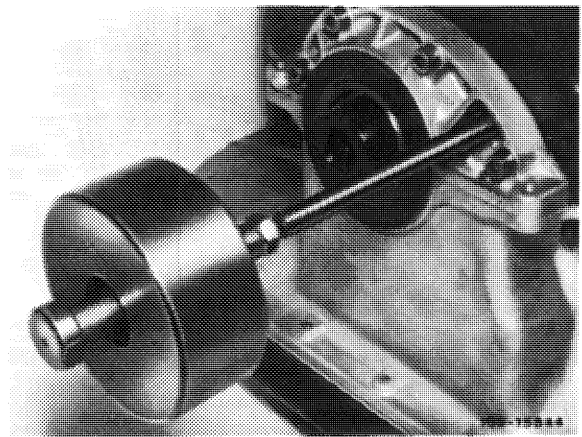

Installation

- 7 Coat both bearing bolts on flange with sealing compound.
- 8 Position slide rail and knock in bearing bolts by means of impact puller.

Attention!

Locating lug of slide rail should rest in locating groove of lower bearing bolt (arrow).

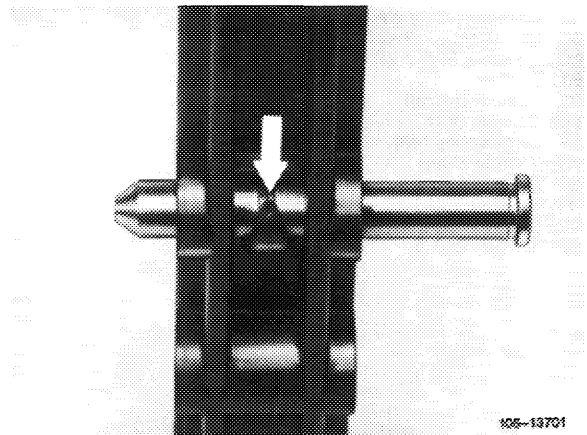

- 9 Install injection timer (07.1–210).
- 10 Attach vacuum pump (42–610).
- 11 Install radiator and fan.
- 12 Mount cylinder head cover.

Timing chain, tensioning and slide rails

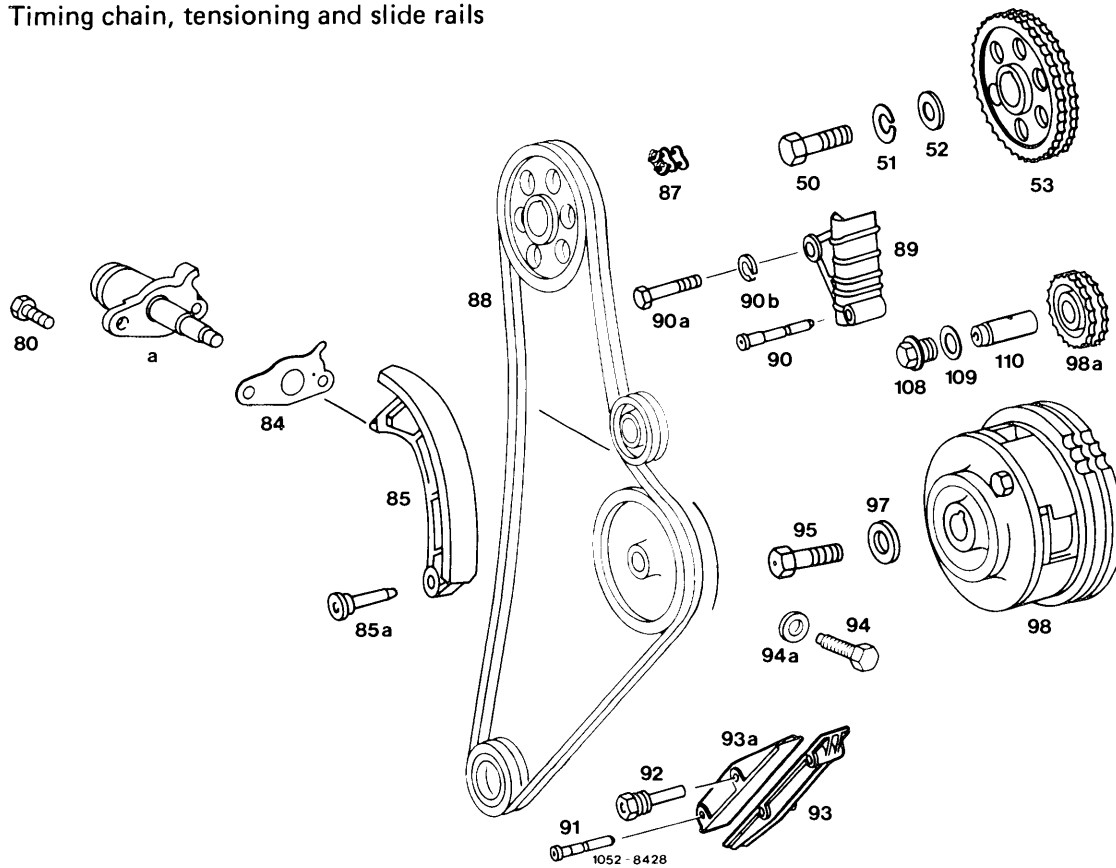





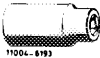

- 50 Necked-down screw M 14 x 1.5 x 40
- 51 Snap ring B 14
- 52 Compensating washer
- 53 Camshaft sprocket
- 80 2 screws M 8 x 20
- 84 Gasket
- 85 Tensioning rail
- 85a Bearing bolt
- 87 Connecting link
- 88 Timing chain
- 89 Slide rail
- 90 Bearing bolt
- 90a Screw M 8 x 50
- 90b Snap ring A 8

- 91 3 bearing bolts
- 92 Closing plug with bearing bolt
- 93 Outer slide rail
- 93a Inner slide rail
- 94 Chain locking screw
- 94a Sealing ring A 12 x 17
- 95 Screw M 10 x 45
- 97 Washer
- 98 Injection timer
- 98a Guide wheel
- 108 Closing plug
- 109 Sealing ring
- 110 Shaft
- a Chain tensioner

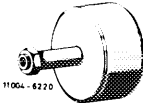
05—412 Removal and installation of intermediate sprocket shaft

Tightening torques	Nm
Nuts for cylinder head cover	15
Necked-down screw for camshaft sprocket	80
Fastening screw for injection timer	40
Coupling nuts for injection lines	25
Closing plug for chain tensioner	90

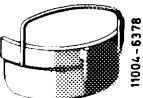
Socket 27 mm, 1/2" square, for rotating engine		001 589 65 09 00
Box wrench socket, open, 17 mm, 1/2" square, for injection lines		000 589 68 03 00
Impact puller for bearing bolt (basic unit)		116 589 20 33 00
Threaded bolt M 6, 50 mm long for impact puller		116 589 01 34 00
Articulated wrench		000 589 21 07 22
Overflow pipe		636 589 02 23 00
Holding plate		616 589 02 40 00

Note

The injection timer is mounted on intermediate sprocket shaft with a screw M 10 x 45 (95).

On engine 617.950 with double diaphragm vacuum pump, the screw has a hollow shaft.

The vacuum pump is provided with the required oil through this hollow screw.

Layout of double diaphragm vacuum pump

- | | |
|------------------------|-------------------------------------|
| 94 Chain locking screw | 101 Lock washer |
| 95 Screw M 10 x 45 | 102 Bearing bushing front |
| 97 Washer | 103 Woodruff key |
| 98 Injection timer | 104 Intermediate sprocket shaft |
| 99 Screw M 6 x 12 | 105 Bearing bushing rear |
| 100 Snap ring B 6 | 109 Bearing bushing injection timer |

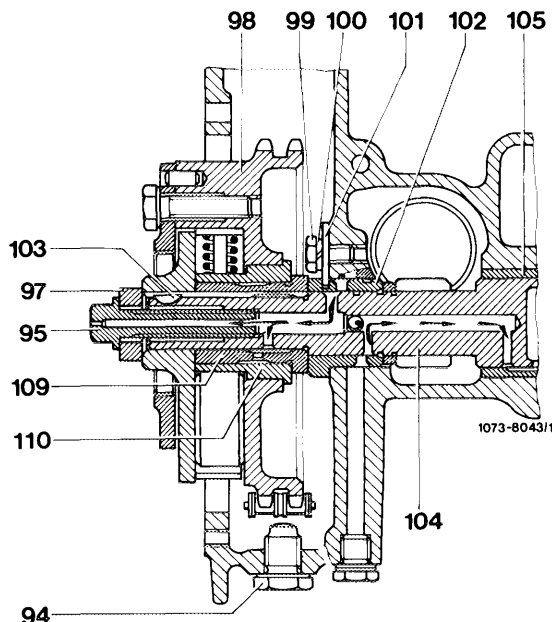

On engines with piston vacuum pump, screw (95) is not hollow.

Do not mix up screws (95).

Layout with piston vacuum pump

- | | |
|--------------------|---------------------------------|
| 94 Locking screw | 101 Lock washer |
| 95 Screw M 10 x 45 | 102 Bearing bushing front |
| 97 Washer | 103 Woodruff key |
| 98 Injection timer | 104 Intermediate sprocket shaft |
| 99 Screw M 6 x 12 | 105 Bearing bushing rear |
| 100 Snap ring B 6 | 109 Bearing bushing |

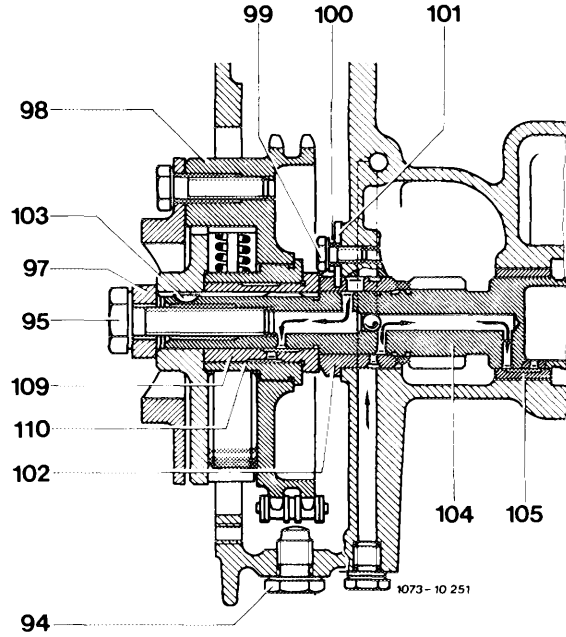

On engine 617.950 since August 1978, and on engines 617.951/952 since start of series, the intermediate sprocket shaft (B) and the rear bearing bushing (B) of engines 615, 616 and 617.912 are installed for reasons of standardization.

These parts can also be installed on engines 617.950 manufactured at an earlier date.

- A Intermediate sprocket shaft 1st version
- B Intermediate sprocket shaft 2nd version

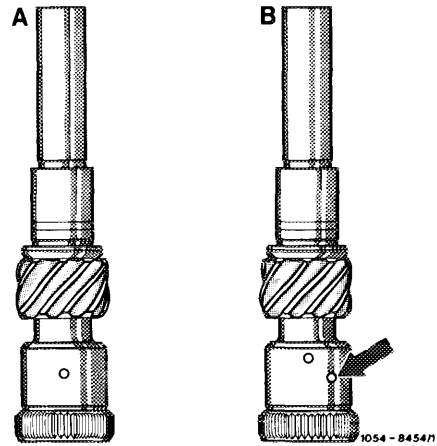

- A Rear bearing bushing 1st version
- B Rear bearing bushing 2nd version

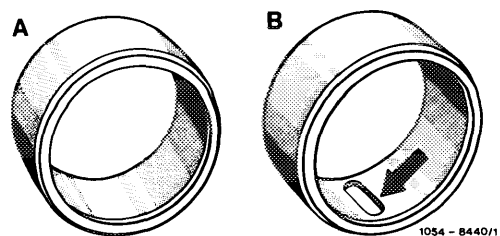

Removal

- 1 Remove fan and radiator shell.
- 2 Remove vacuum pump (42–610).
- 3 Remove injection timer (07.1–210).
- 4 Remove injection pump (07.1–180).
- 5 Pull out intermediate sprocket shaft toward the rear.

Installation

- 6 Insert intermediate sprocket shaft from the rear.
- 7 Install injection timer (07.1–210).
- 8 Install injection pump (07.1–180).
- 9 Check timing of camshaft (05–215) and begin of delivery (injection timing) of injection pump (07.1–110).
- 10 Install vacuum pump (42–610).
- 11 Install fan and radiator shell.

Intermediate sprocket shaft and injection timer

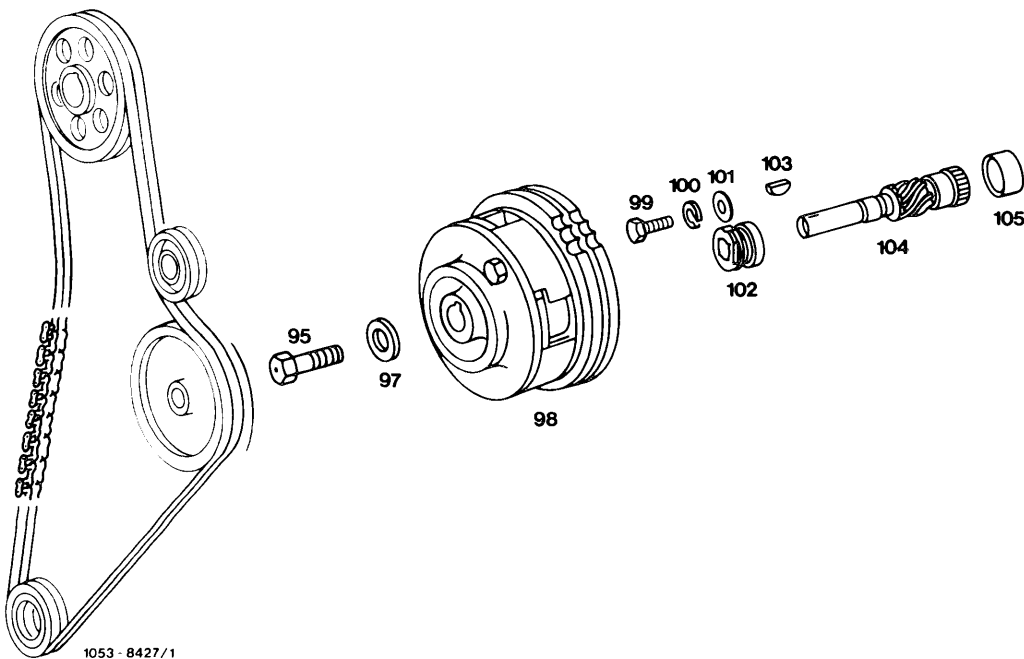



- 95 Screw M 10 x 45
- 97 Washer
- 98 Injection timer
- 99 Screw M 6 x 12
- 100 Snap ring B 6

- 101 Lock washer
- 102 Bearing bushing front
- 103 Woodruff key
- 104 Intermediate sprocket shaft
- 105 Bearing bushing rear

05-440 Removal and installation of guide wheel

Tightening torques	Nm
Nuts for cylinder head cover	15
Necked-down screw for camshaft sprocket	80
Closing plug for chain tensioner	90
Pressure oil pump on cylinder head	10

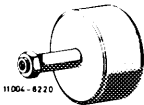
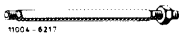
Special tools

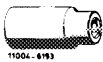
Impact puller for bearing bolt (basic unit)		116 589 20 33 00
Threaded bolt M 8, 150 mm long for impact puller		616 589 00 34 00
Threaded bolt M 6, 50 mm long for impact puller		116 589 01 34 00
Socket 27 mm, 1/2" square, for rotating engine		001 589 65 09 00

Note

If, on model 123 with level control, the rear bearing bushing for guide wheel shaft requires renewal, make sure that the bearing bushing on basic bore projects by 1 mm. Do not install bushing flush.

Removal

- 1 On model 123 with level control, unscrew pressure oil pump with lines connected and put aside.

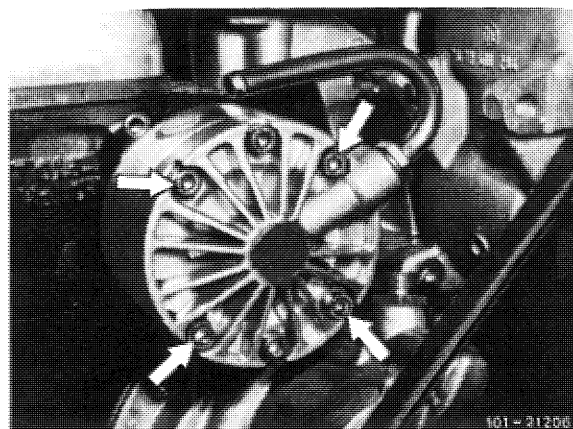

2 Disconnect regulating linkage to remove cylinder head cover. Pull out locking eye of longitudinal regulating shaft (arrow).

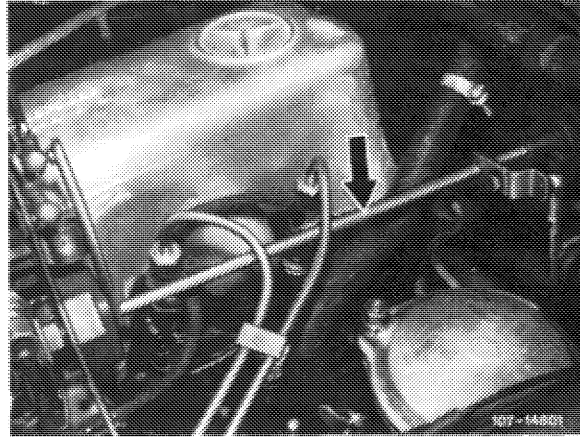

Model 116.120

On models 116.120 and 123, pull longitudinal regulating shaft out of rubber mount in forward direction and remove in rearward direction.

On model 126.120, pull longitudinal regulating shaft out of guide lever in rearward direction and remove in forward direction.

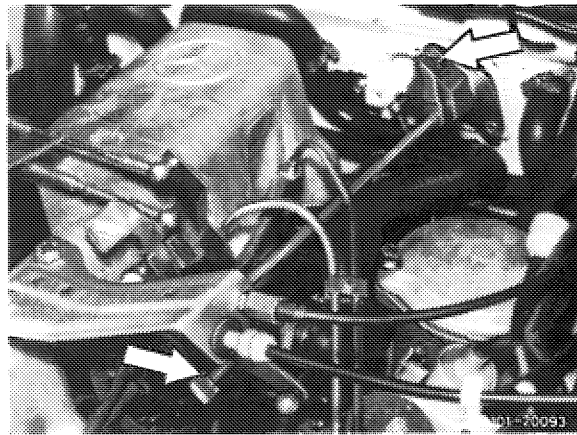

Model 123

On models 123 with automatic transmission 722.303 (W 4 A 040) and 126.120, pull out central plug for vacuum lines (71) or vacuum lines. Disconnect Bowden wire, compress black plastic clip (arrow) and pull Bowden wire out of holder in rearward direction.

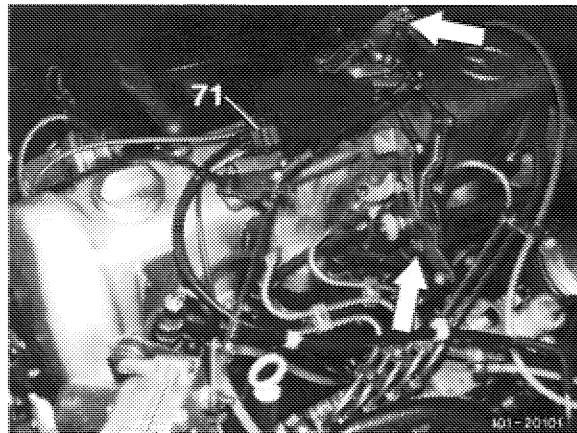

Model 126.120

3 Set crankshaft to ignition TDC.

For this purpose, rotate crankshaft by means of tool combination.

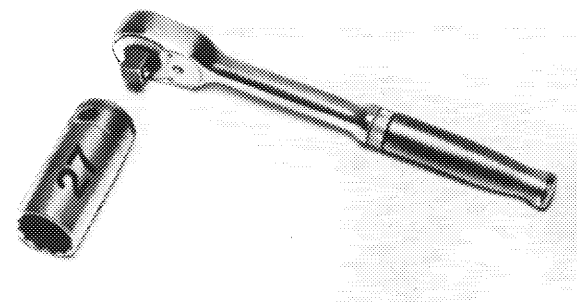

1100-6438/1

4 On engines with EGR (USA), remove pipe line between EGR valve and exhaust manifold (arrow). Unscrew shielding plate (10) for this purpose.

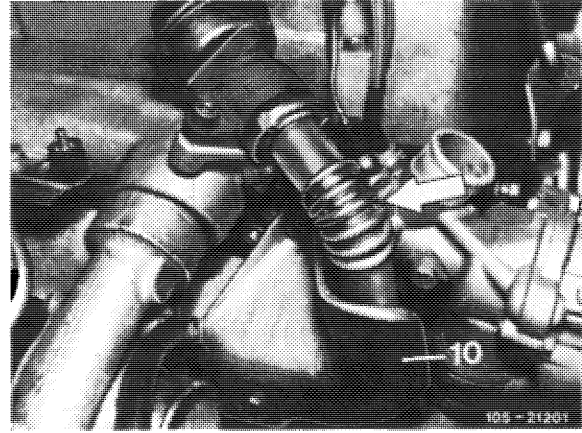

5 Unscrew closing plug of chain tensioner.

Attention!

Closing plug is under pressure of compression spring.

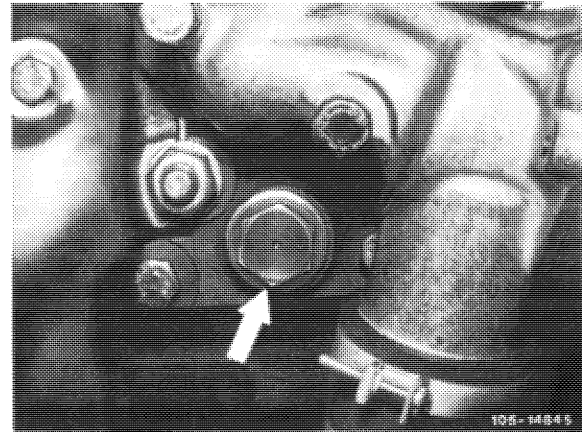

6 Remove compression spring in chain tensioner.

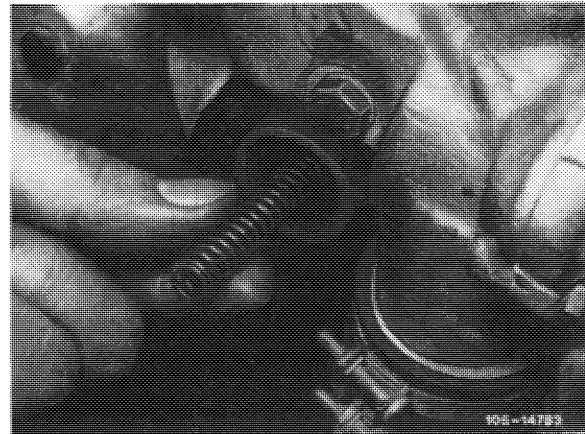

7 Mark camshaft sprocket and timing chain in relation to each other.

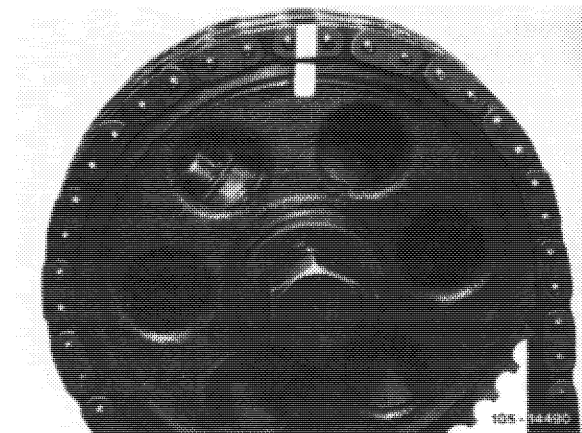

8 Remove slide rail in cylinder head.

Pull out bearing bolt by means of impact puller.

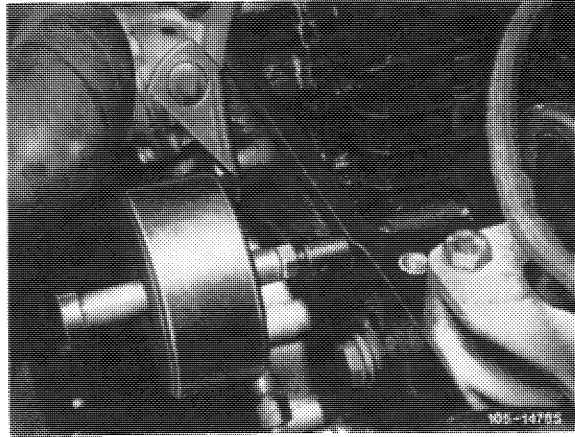
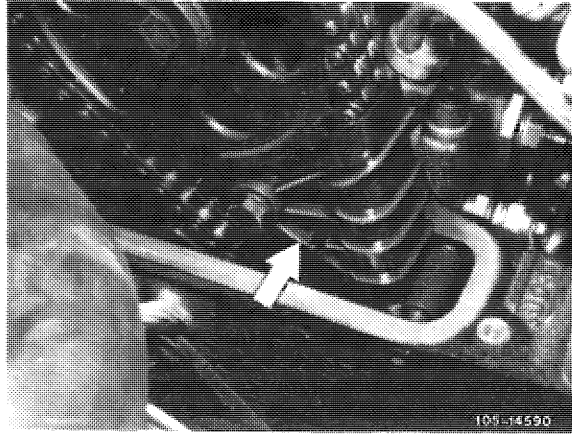

9 Remove camshaft sprocket.

For loosening necked-down screw, apply counterhold to camshaft sprocket by means of a screwdriver or steel bolt.

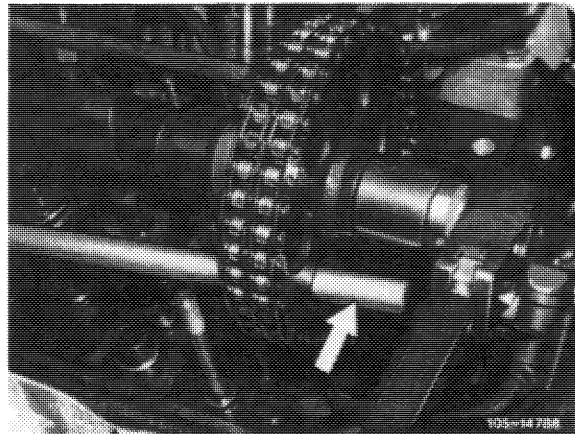

10 On engines 617.950/951, unscrew closing plug (arrow).

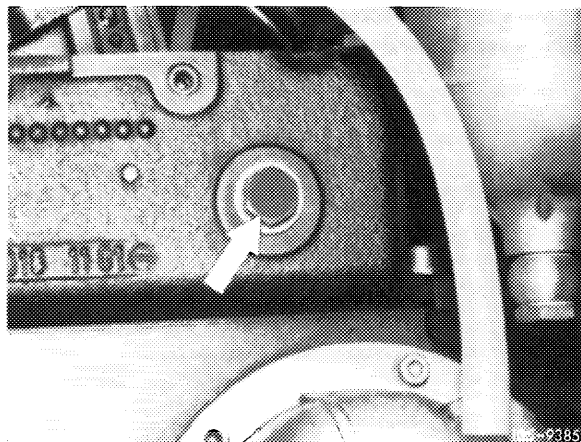

11 Pull out shaft (110) by means of impact puller and remove guide wheel (98a) in upward direction.

98a Guide wheel
108 Closing plug
109 Sealing ring
110 Shaft

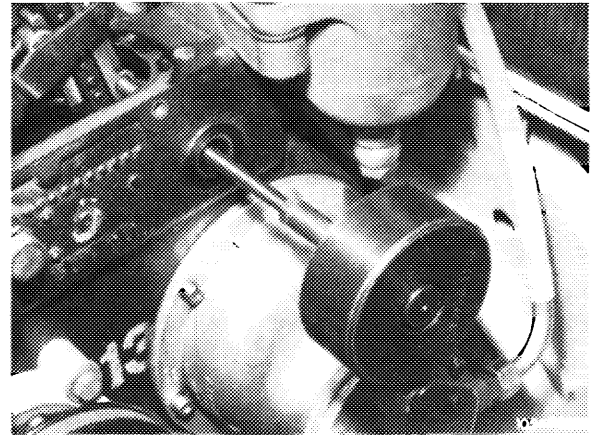
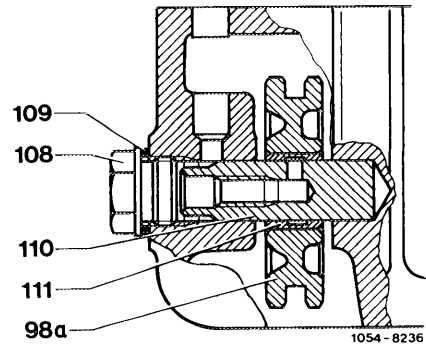

12 On model 123 with level control, unscrew locking screw of front bearing bushing (arrow).

Pull out shaft together with bearing bushing and remove guide wheel.

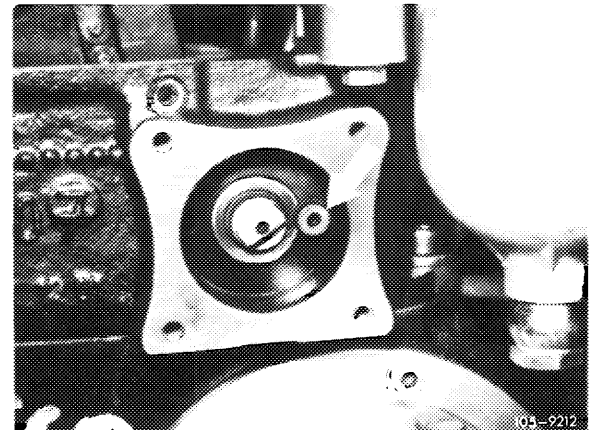

Installation

13 Position guide wheel and slip in shaft.

On model 123 with level control, screw in bearing bushing locking screw (arrow in Fig. item 12).

14 Screw in closing plug with new sealing ring.

On model 123 with level control, screw on pressure oil pump with new gasket.

15 Mount camshaft sprocket, while paying attention to color marks.

Tighten necked-down screw to 80 Nm. For this purpose, apply counterhold to camshaft sprocket by means of a screwdriver or steel bolt.

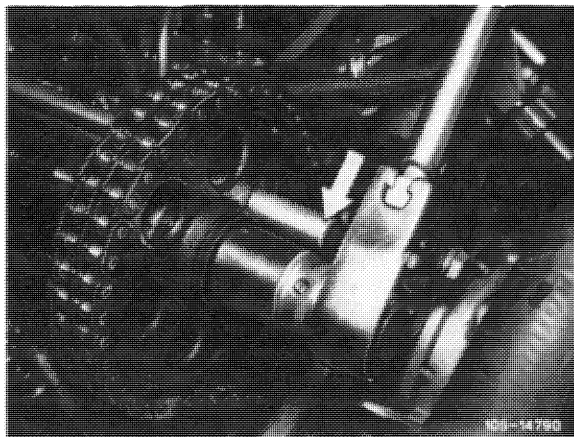

16 Install slide rail.

17 Rotate crankshaft and check adjusting mark in TDC position of engine.

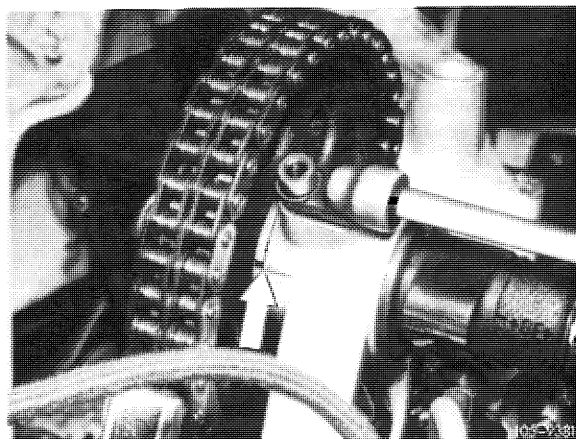

18 Insert compression spring into chain tensioner and tighten closing plug to 90 Nm.

19 On engines with EGR (USA), install shielding plate and pipe line (Fig. item 4).

20 Mount cylinder head cover.

