

A. General information

On a diesel engine, combustion is effected by self-ignition of the fuel sprayed into the highly compressed and thereby highly heated combustion air.

In the cold engine, the self-ignition temperature is not attained by compression alone. A preglow system is therefore required, which serves the purpose of increasing the temperature of the compressed air to facilitate the firing of the cold engine by the ignition of fuel particles on filament of glow plug.

The duration of preglowing depends on temperature of engine and on ambient temperature.

Design of pencil element glow plugs

Pencil element glow plugs consist essentially of a housing with M 12 x 1.25 screw-in threads and a pencil element pressed into housing.

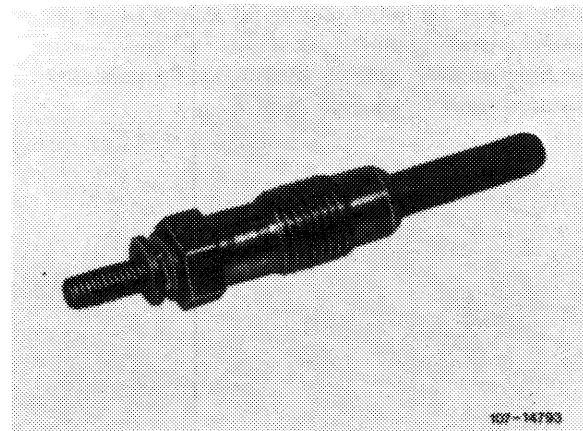

The single-pole connecting pin is glued to housing by means of a non-releasable round aluminum nut.

The pencil element glow plugs are designed for a current of 11 volts and are operated in parallel.

The pencil element is heated indirectly by means of a heater element. This heater element, a coil made of a resistance wire, is embedded and insulated in a ceramic compound.

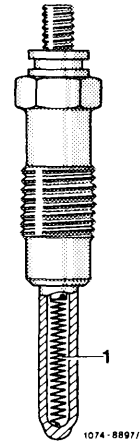

When the glow system is switched on, each glow plug is subject to a current of approx. 20 amps (peak impulse of approx. 40 amps).

Under the influence of increasing heat, the inherent resistance of the glow plug increases and will limit the current to approx. 8 amps.

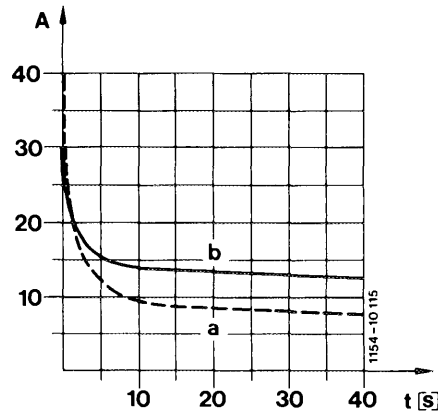

a Current curve of pencil element glow plug

After a glow period of approx. 20 seconds a heater pencil element temperature of 900 °C/1652 °F will be attained, after approx. 50 seconds the max. temperature will be 1080 °C/1976 °F.

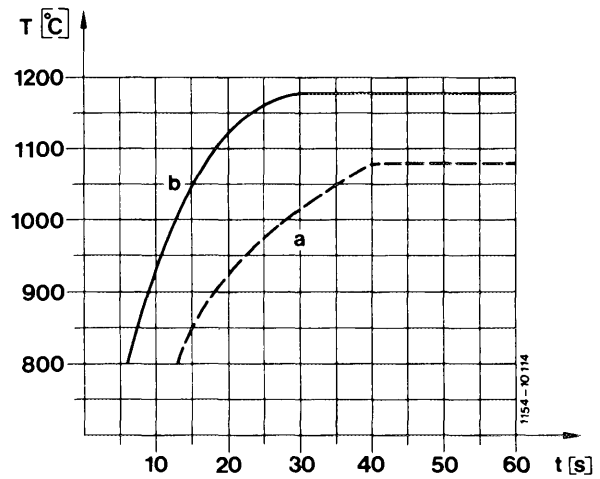

a Temperature curve of pencil element glow plug

Design of quick-start pencil element glow plugs

Except for heater element, the design of a quick-start pencil element glow plug is the same as that of a pencil element glow plug.

As an external identification, the connecting pin is screwed to the housing by means of a non-releasable round brass nut.

The heater element consists of a heater and control coil connected in series.

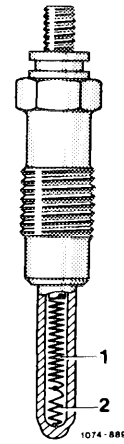

When the glow system is switched on, each glow plug will be subject to a current of approx. 30 amps.

The glow plug is heated very quickly by heater coil. With increasing temperature, the control coil increases its resistance and limits the current to approx. 8–15 amps. This will protect the glow plug against overloads.

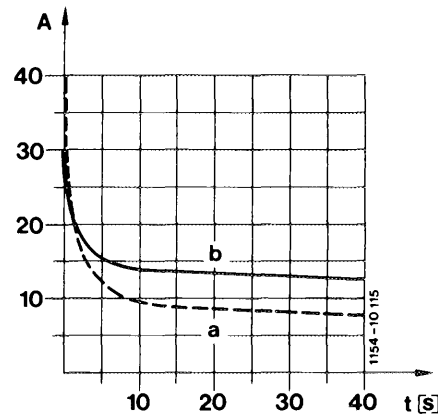

b Current curve of quick-start pencil element glow plug

After a glow period of 9 seconds a pencil element temperature of approx. 900 °C/1652 °F is attained, after 30 seconds the max. temperature amounts to 1180 °C/1976 °F.

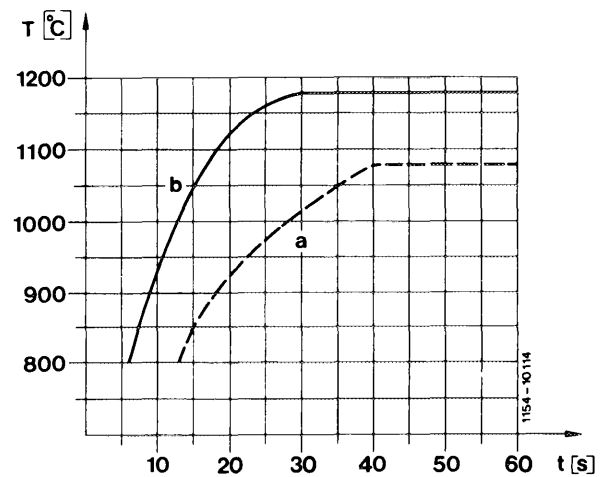

b Temperature curve of quick-start pencil element glow plug

B. Preglow system engine 617.950 (USA) 1978–1980

General information

The essential components of the preglow system are the pencil element glow plugs, model year 1980 quick-start pencil element glow plugs, preglow time relay, temperature sensor and preglow indicator lamp.

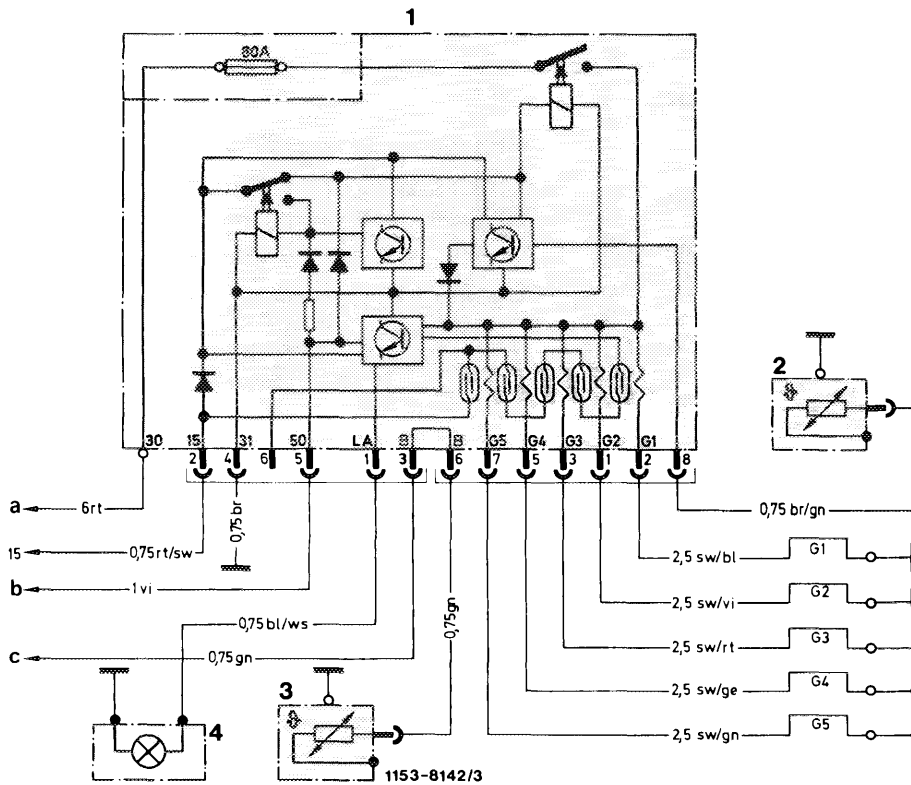

Wiring diagram

- 1 Preglow time relay
- 2 Temperature sensor preglow system
- 3 Temperature sensor coolant
- 4 Preglow indicator lamp

- G 1 – G 5 Pencil element glow plugs
- a Cable connector engine harness terminal 30
- b Relay air conditioning/starter terminal 50
- c Plug instrument cluster jack 3

cardiagn.com

The pencil element glow plugs are designed for a current of 11 volts and connected in parallel. For this reason, preglowing will proceed even if one pencil element glow plug fails.

Preglow time relay

The preglow time relay is located in engine compartment at left of wheel house.

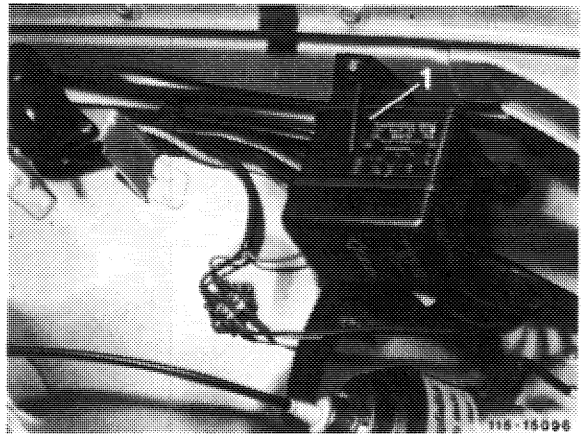

Upon removal of clipped-on cap on preglow time relay the 80-amps fuse and the electric connections will be accessible.

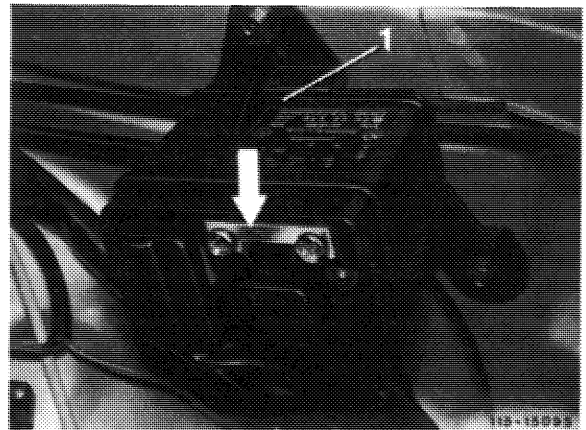

Functions of preglow time relay

The preglow time relay has the following functions:

- Switching of glow current
- Ready-to-start indicator
- Safety shutoff
- Fault indicator

Switching of glow current

When the preglow system is switched on in key position "2" (preglowing, driving) the preglow time relay is activated by terminal 15 of starter switch.

The power relay in preglow time relay closes the circuit of terminal 30 (battery +) via 80-amps fuse to pencil element glow plugs.

When the key is turned into position "3" (start) the power relay — activated by terminal 50 — remains in energized condition. The glow process continues until the key is turned to position "2".

Ready-to-start indicator

A temperature sensor installed in coolant circuit determines the glow period in preglow time relay.

When the glow system is switched on, the preglow indicator lamp in instrument cluster lights up.

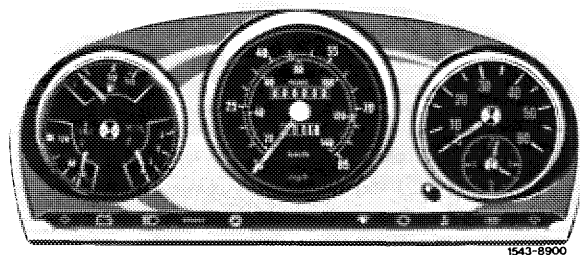

As soon as the required glow period, depending on coolant temperature, is attained, the preglow indicator lamp goes out and thereby indicates ready-to-start condition.

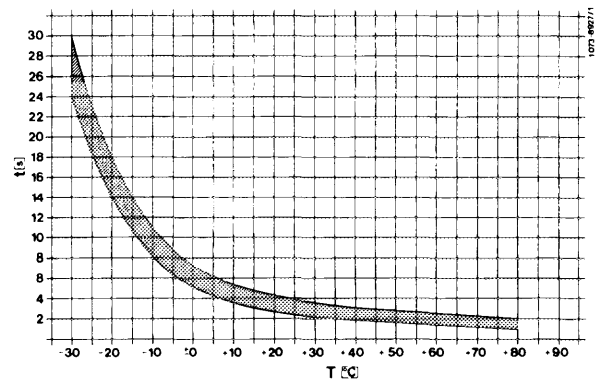

Safety shutoff

If there is no start following indication of ready-to-start condition, the glow current is interrupted by the safety shutoff, after 90 + 20 seconds for model year 1978/1979, after 50 + 10 seconds for model year 1980.

For subsequent starting, the glow system is again switched on via terminal 50 for the duration of the starting procedure.

Fault indicator

A functional fault of the preglow system is indicated by the preglow indicator lamp during or after the preglowing has been completed.

The preglow indicator lamp is controlled by the electronic system in preglow time relay.

If the glow current circuit is interrupted, e.g. by a defective 80-amps fuse or power relay in preglow time relay, the electronic system receives no current from terminal 30 and the preglow indicator lamp will flash for approx. 30 seconds after the preglow system has been switched on.

If one or several pencil element glow plugs or lines are interrupted, the preglow indicator lamp will flash for approx. 30 seconds after starting.

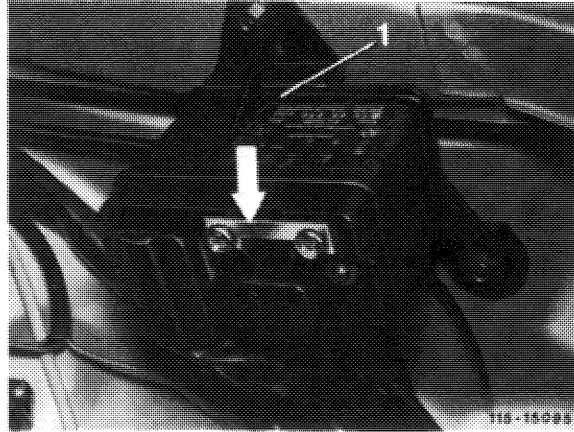

For preglowing, the current flows through the Reed contact coils located in respective glow current circuits.

The resulting magnetic field will close the Reed contacts and a voltage from terminal 15 will be applied to electronic system.

If this voltage is interrupted, for example by a failing pencil element glow plug (the respective Reed contact remains open) the preglow indicator lamp will flash for approx. 30 seconds after starting.

C. Preglow system engine 617.95 standard version and  starting 1981

General information

The preglow system corresponds in principle to system of model year 1980.

The preglow time relay has been modified. In addition, the temperature sensor in coolant circuit is no longer installed.

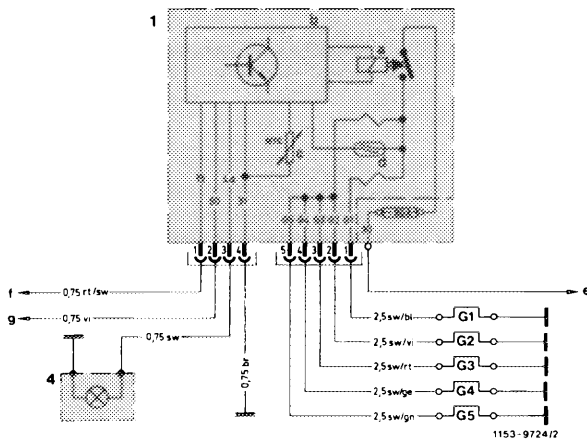

Wiring diagram

- 1 Preglow time relay
- a Power relay
- b Electronics
- c Temperature sensor (NTC resistor)
- d Reed relay
- 4 Preglow time relay
- e To cable connector engine harness
Terminal 30 in model 123
To point of support in fuse box
Terminal 30 in model 126

- f To fuse box terminal 15
- g To plug connection starter lockout and backup lamp switch terminal 50
- G 1 – G 5 Pencil element glow plugs

Preglow time relay

The preglow time relay is located in engine compartment at left on wheel house.

After removing plugged-on protective cap, the electrical connections as well as the fuse strip are accessible.

Relay layout on engine 617.951

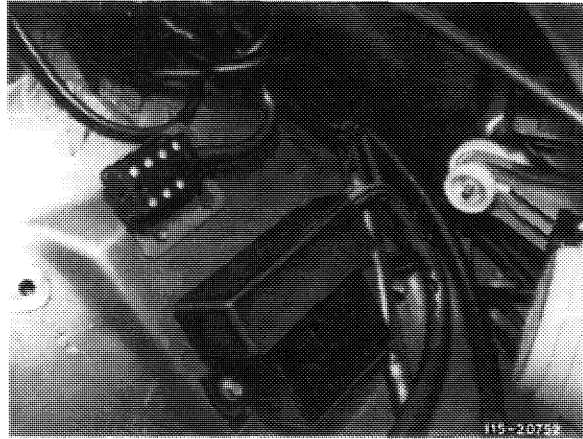

Relay layout on engine 617.952

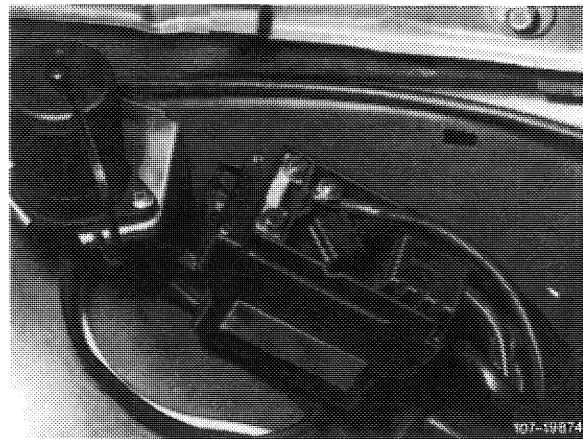

The temperature sensor installed up to now in coolant circuit is no longer installed. Instead, the relay or relay ambient temperature is obtained by means of an NTC resistor in preglow time relay.

Functions of preglow time relay

The preglow time relay has the following functions:

- Switching of glow current
- Ready-to-start indicator
- Safety shutoff
- Fault indicator

Switching of glow current

When turning key into position "2" (preglowing, driving) the preglow time relay (current on terminal 15) is switched on. The power relay (a) closes the circuit of terminal 30 (plus) via fuse for pencil element glow plugs G 1 – G 5.

- a Power relay
- b Electronic unit
- c Temperature sensor (NTC resistor)
- d Reed relay

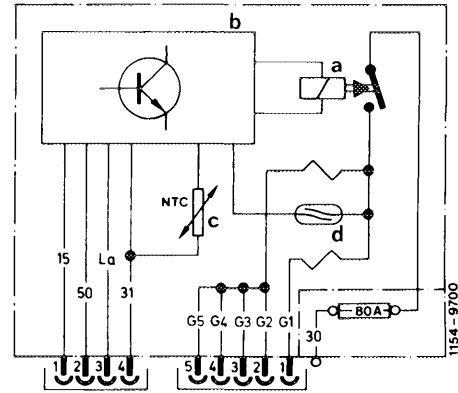

When the key is moved into position "3" (start) the power relay (a) remains in energized condition under influence of terminal 50. Glowing continues until key is again turned into position "2".

Ready-to-start indicator

A temperature sensor installed in preglow time relay determines the duration of the glow period.

When the glow system is switched on, the preglow indicator lamp in instrument cluster lights up.

As soon as the required glow period, depending on ambient temperature of preglow time relay, has been attained, the preglow indicator lamp will go out and thereby indicate ready-to-start condition.

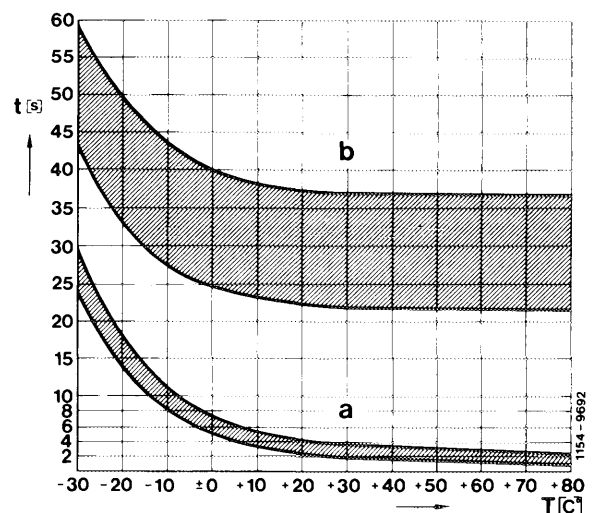

a Preglow period

Safety shutoff

If, upon indication of ready-to-start condition, there is no start within 20–35 seconds, the glow current is interrupted by the safety shutoff. For a subsequent start, the glow system is again switched on for the duration of the starting procedure.

The safety shutoff is no longer fixed, but is the result of the time up to ready-to-start condition (preglow indicator lamp goes out) plus 20 to 35 seconds.

a Preglow period
b Safety shutoff

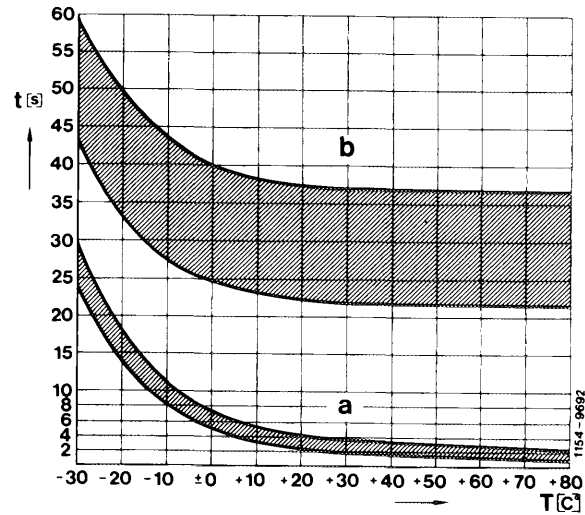

Fault indicator

A fault in preglow system is indicated by the preglow indicator lamp **not lighting up** when key is actuated in position "2".

The following faults are recognized:

- Interruption of line to connection terminal 30.
- Fuse 80 Amps. defective.
- Power relay in preglow time relay defective.

- Interruption of one or several lines to pencil element glow plugs.
- Interruption of one or several pencil element glow plugs.

Note: In the event of unfavorable tolerances of pencil element glow plugs or of Reed relay (d), response of fault indicator only after two pencil element glow plugs are defective is allowed.

Faults (monitoring of pencil element glow plugs) are indicated by comparing the current of the pencil element glow plug G 1 with current of remaining pencil element glow plugs G 2 to G 5 connected in parallel.

- a Power relay
- b Electronic unit
- c Temperature sensor (NTC resistor)
- d Reed relay

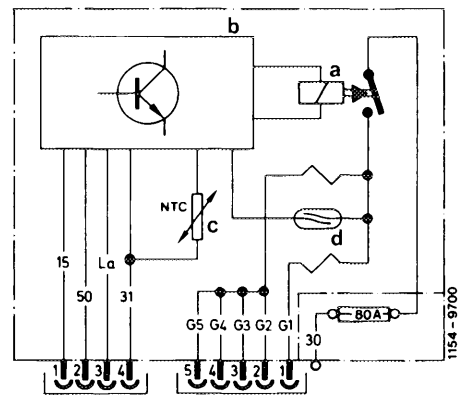

The currents of the two lines to pencil element glow plugs G 1 and G 2 to G 5 are flowing through two oppositely oriented Reed relay windings having a different number of turns in windings.

If the current flow in both windings is the same, the magnetic fields will cancel each other and the Reed contact will not respond.

If the balance of the magnetic fields is interrupted by the failure of one or several pencil element glow plugs, the Reed contact will close and the electronic unit (b) will be activated.

The preglow indicator lamp will switch off immediately and will therefore not light up when preglowing starts.

- a Power relay
- b Electronic unit
- c Temperature sensor (NTC resistor)
- d Reed relay

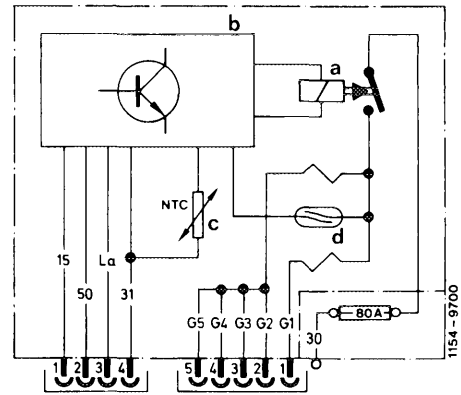

Note

Since September 1981 a preglow time relay with modified ventilation is installed for quick-start preglow system. The part number has not been changed.

In the modified version of the preglow time relay, ventilation proceeds via coding pin (1). The coding pin (2) is also longer as before and the 5-pole coupler has been designed in such a manner that the ventilation is covered. In the former preglow time relay ventilation proceeded through a bore in housing.

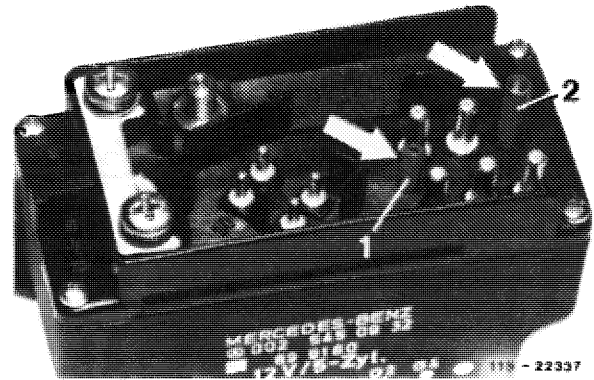

Modified preglow time relay
 1 Ventilation
 2 Higher coding pin

The modified preglow time relay can also be installed in vehicles prior to September 1981. In such a case, the modified 5-pole coupler must also be installed, since otherwise moisture may enter the relay.

Upon installation of the new relay, convert coupler of harness to new ventilation.

Layout of 5-pole coupler:

- Jack 1 of coupler = Pencil element glow plug cylinder 1-2.5 black/blue
- Jack 2 of coupler = Pencil element glow plug cylinder 2-2.5 black/purple
- Jack 3 of coupler = Pencil element glow plug cylinder 3-2.5 black/red
- Jack 4 of coupler = Pencil element glow plug cylinder 4-2.5 black/yellow
- Jack 5 of coupler = Pencil element glow plug cylinder 5-2.5 black/green

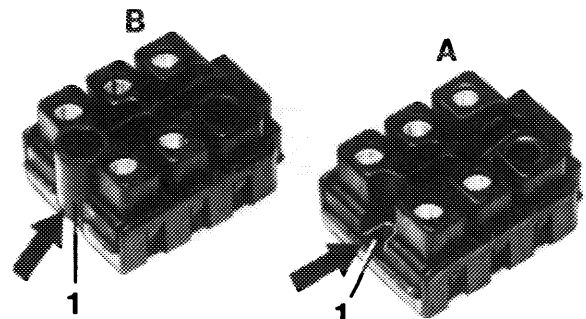

5-pole coupler
 A 1st version
 B 2nd version

115-22336

Checking main circuit of preglow system for interruption

In the event of an interruption:

Preglow indicator lamp will flash for approx. 30 seconds in key position "2 preglowing".

Test voltage at terminal 30 of preglow time relay against ground by means of voltmeter. If no voltage is indicated (approx. 12 volts), check red line from cable connector engine harness to preglow relay terminal 30 for interruption and remove interruption, if applicable.

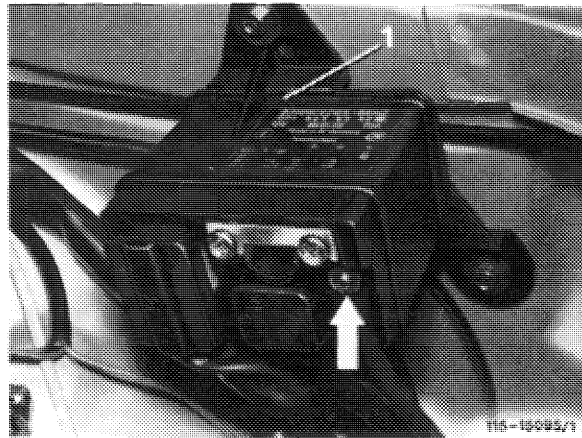

If voltage is indicated, check 80-amps fuse for tight seat or for interruption, replace fuse.

If no faults have been found during tests, replace preglow time relay.

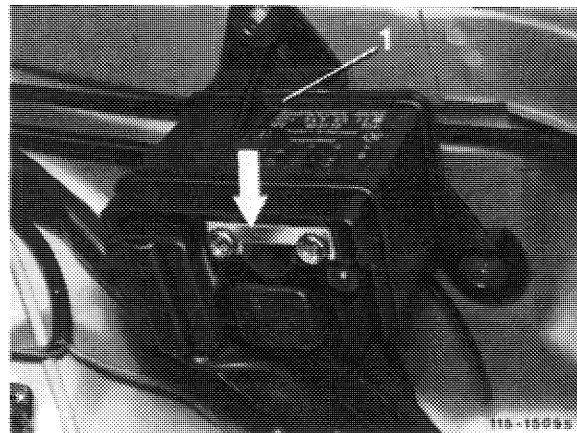

Testing glow bulb, temperature sensor of preglow system and their lines

In the event of an interruption:

Preglow indicator lamp not lighting up in spite of ready-to-start condition.

Pull 6-point coupler from preglow relay, turn key to position "2", bridge jack 1 and 2 of coupler.

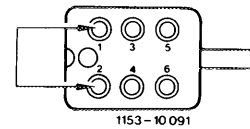

If preglow indicator lamp is not lighting up, check glow bulb or renew, if required. If glow bulb is in order, test blue/white line from coupler jack 1 of preglow time relay to preglow indicator lamp for interruption, remove interruption.

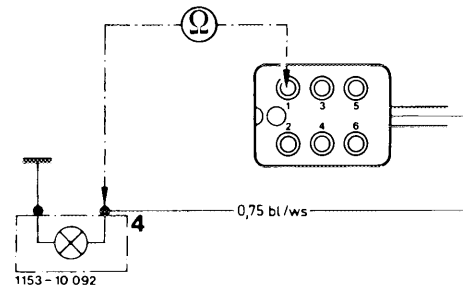

If preglow indicator lamp lights up, test green line from 8-point coupler jack 8 of preglow time relay to temperature sensor for interruption, remove interruption.

If no interruption is found, test temperature sensor or renew, if required.

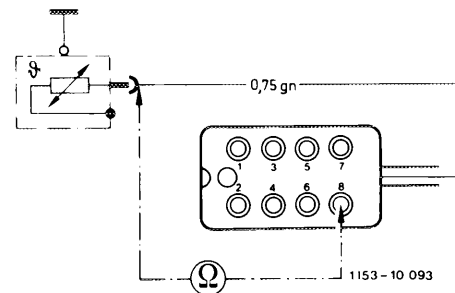

Resistance values of temperature sensor at coolant temperature:

- 0 °C = 8200 Ω
- + 25 °C = 2440 Ω
- + 80 °C = 290 Ω

If temperature sensor is in order, replace preglow time relay.

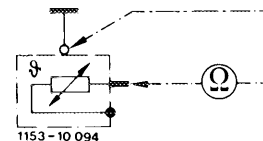

Testing activation of preglow time relay

In the event of an interruption:

Preglow indicator lamp not lighting up, engine cannot be started.

Pull 6-point coupler from preglow time relay, turn key into position "2".

Test voltage at jack 2 (terminal 15) against ground by means of voltmeter.

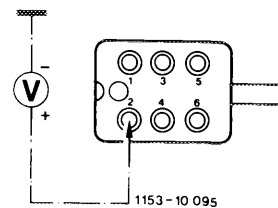

If there is no voltage (approx. 12 volts) on red/black line from fuse box (terminal 15, non-fused side) to coupler jack 2 of preglow time relay for interruption and remove interruption, if required.

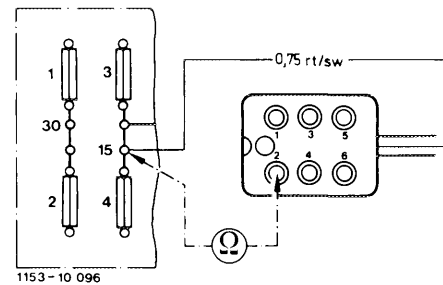

If voltage is indicated, connect voltmeter to jack 2 (terminal 15) and jack 4 (terminal 31) and test voltage.

If no voltage (approx. 12 volts) is indicated, test brown line from jack 4 to ground for interruption and remove interruption, if applicable.

If voltage is indicated, preglow time relay is defective. Replace preglow time relay.

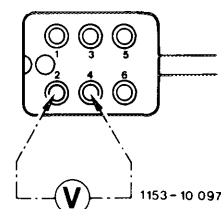

Testing pencil element glow plugs and their lines

In the event of a complaint:

Preglow indicator lamp flashes approx. 30 seconds after a completed start or start attempt, the cause may be an interruption of a pencil element glow plug or a line to pencil element glow plugs of cylinder 1–5, or by a wrong current input of the pencil element glow plugs in cylinders 1–5.

Measure current input of pencil element glow plugs with DC clip-on probe. For this purpose, place probe over the individual lines on pencil element glow plugs.

Move key in steering lock to position "2", the power input of each glow plug should then be 8–15 Amps. after 10–20 seconds.

At a value above 15 Amps., renew glow plug.

At a value below 8 Amps., test electric line or glow plug with ohmmeter for interruption.

Test for interruption:

Pull 8-point coupler from preglow time relay.

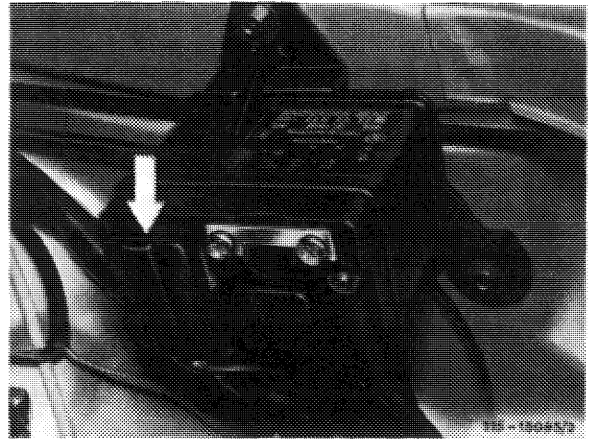

Measure resistance against ground (engine block) by means of ohmmeter one after the other at

- jack 1 of coupler = pencil element glow plug cylinder 2
- jack 2 of coupler = pencil element glow plug cylinder 1
- jack 3 of coupler = pencil element glow plug cylinder 3
- jack 5 of coupler = pencil element glow plug cylinder 4
- jack 7 of coupler = pencil element glow plug cylinder 5.

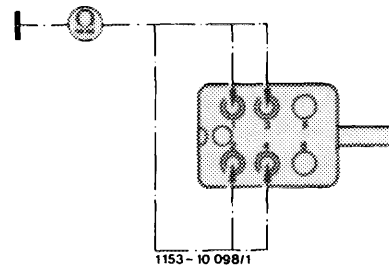

If resistance ∞ is measured, an interruption of respective pencil element glow plug or supply line or connection is indicated.

If a lower resistance (e.g. at 20 °C/68 °F $< 1 \Omega$) is measured, the supply line and the pencil element glow plug are in order.

B. Engine 617.95 standard and (USA) version starting 1981 (quick-start system)

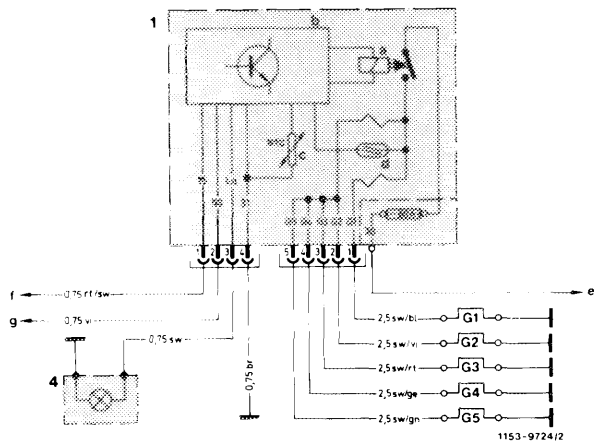

Wiring diagram

- 1 Preglow time relay
- a Power relay
- b Electronic unit
- c Temperature sensor (NTC resistor)
- d Reed relay
- 4 Preglow indicator lamp
- e To cable connector engine harness
Terminal 30 in model 123
To point of support in fuse box
Terminal 30 in model 126
- f To fuse box terminal 15
- g To plug connection starter lockout and backup
lamp switch terminal 50
- G 1 – G 5 Pencil element glow plugs

Testing glow bulb and its line

In the event of an interruption:

Preglow indicator lamp not lighting up when preglow system is switched on in spite of ready-to-start condition.

Pull 4-point coupler from preglow time relay, turn key into position "2", bridge jack 1 and 3 of coupler.

If preglow indicator lamp is not lighting up, test glow bulb and renew, if required.

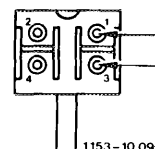

If glow bulb is in order, test black line from coupler jack 3 of preglow time relay to preglow indicator lamp for interruption, remove interruption.

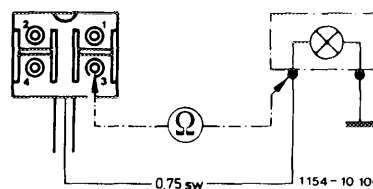

If preglow indicator lamp lights up, preglow time relay is defective, replace preglow time relay.

Installation not concerning preglow time relay

If a preglow time relay has been stored in spare parts sector for a considerable period (refer to production date), the specified preglow time may be below specification after the relay has been installed, so that the engine will not start.

By preglowing several times one upon the other (5 – 10 times) the capacitor in preglow time relay is again activated and the specified preglow time is attained.

Testing main circuit of preglow system for interruption

In the event of an interruption:

Preglow indicator lamp not lighting up, engine cannot be started.

Test voltage at terminal 30 of preglow time relay against ground by means of voltmeter.

If no voltage (approx. 12 volts) is indicated, test red line for interruption and remove interruption, if required.

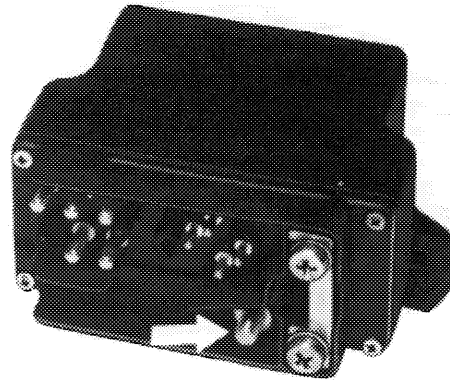

115-20011/1

On model 126 from point of support terminal 30 to preglow time relay connection terminal 30.

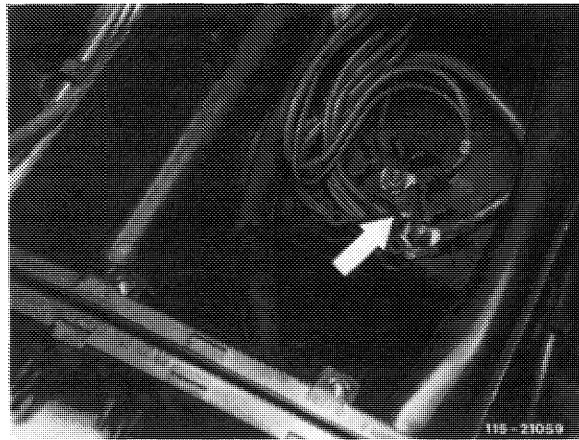

115-21059

On model 123 from cable connector engine harness terminal 30 to preglow time relay connection terminal 30.

If voltage is indicated, check 80-amps fuse for tight seat or interruption and replace, if required.

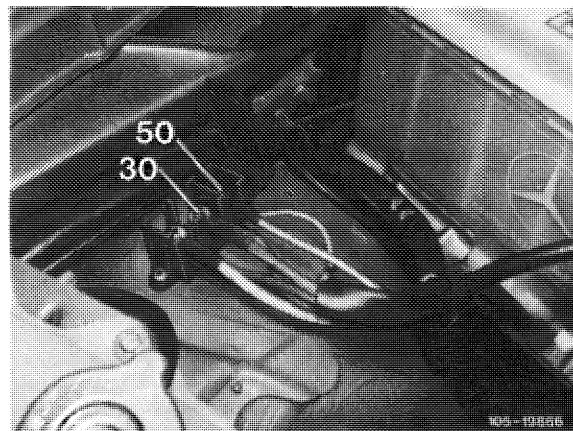

105-19896

If no fault has been found up to now, test voltage on jack 1 of 4-point plug of preglow time relay against ground.

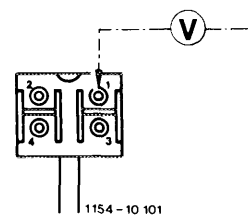

If no voltage (approx. 12 volts) is indicated with preglow system switched on, test red/black line from fuse box terminal 15 to plug jack 1 of preglow time relay for interruption and remove interruption, if required.

On model 126 from input fuse No. 14 to plug jack 1 of preglow time relay.

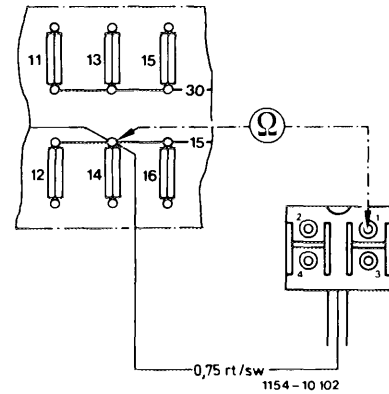

On model 123 from input fuse No. 12 to plug jack 1 of preglow time relay.

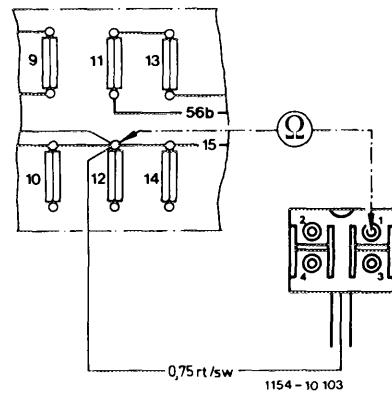

If voltage is indicated, connect voltmeter to jack 1 (terminal 15) and jack 4 (terminal 31) and test voltage.

If no voltage (approx. 12 volts) is indicated, test brown line from jack 4 to ground for interruption and remove interruption, if required.

If no fault has been found up to now, the preglow time relay is defective. Replace preglow time relay.

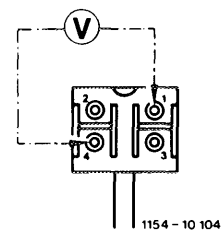

Testing pencil element glow plugs and their lines

In the event of an interruption:

Preglow indicator lamp not lighting up, engine fires poorly, an interruption of one or several pencil element glow plugs or lines to pencil element glow plugs may be indicated.

In the event of an interruption:

Preglow indicator lamp lights up, engine fires poorly after attaining ready-to-start condition, an interruption of a pencil element glow plug or a line to pencil element glow plugs of cylinder 2 to 5 or wrong current input of pencil element glow plugs in cylinder 1 to 5 may be indicated.

Measure power input of pencil element glow plugs with DC clip-on probe.

For this purpose, place probe over individual lines on pencil element glow plugs.

Move key in steering lock to position "2", the power input of each glow plug should then be 8–15 Amps. after 10–20 seconds.

If the value is higher than 15 Amps., renew glow plug.

At a value below 8 Amps., test electric line or glow plug with ohmmeter for interruption.

Test for interruption:

Pull 6-point coupler from preglow time relay.

Measure resistance against ground (engine block) with ohmmeter one after the other at

- jack 1 of coupler = pencil element glow plug cylinder 1
- jack 2 of coupler = pencil element glow plug cylinder 2
- jack 3 of coupler = pencil element glow plug cylinder 3
- jack 4 of coupler = pencil element glow plug cylinder 4
- jack 5 of coupler = pencil element glow plug cylinder 5.

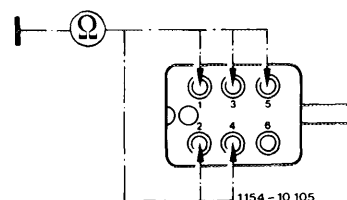

If resistance ∞ is measured, an interruption of the respective pencil element glow plug or supply line or connection is indicated.

If a smaller resistance (e.g. at 20 °C/68 °F $< 1 \Omega$) is measured, the supply line and the pencil element glow plug are in order.

Note: It is possible that an indicator lamp (as the result of unfavorable tolerances) will indicate a fault only after a failure of 2 pencil element glow plugs in cylinders 2 to 5.

To make sure that the fault indication in preglow time relay is not defective, disconnect 2 pencil element glow plugs of cylinders 2 to 5 in such a case and repeat preglow operation.

If the indicator lamp is now indicating a fault (not lighting up) the preglow time relay is in order.