



# WIRING DIAGRAMS

## Fig. 2: Engine Compartment (Cont.) (Grids 4-9)

### 1987 Mercedes-Benz 560SL

Tuesday, November 28, 2000 01:48PM

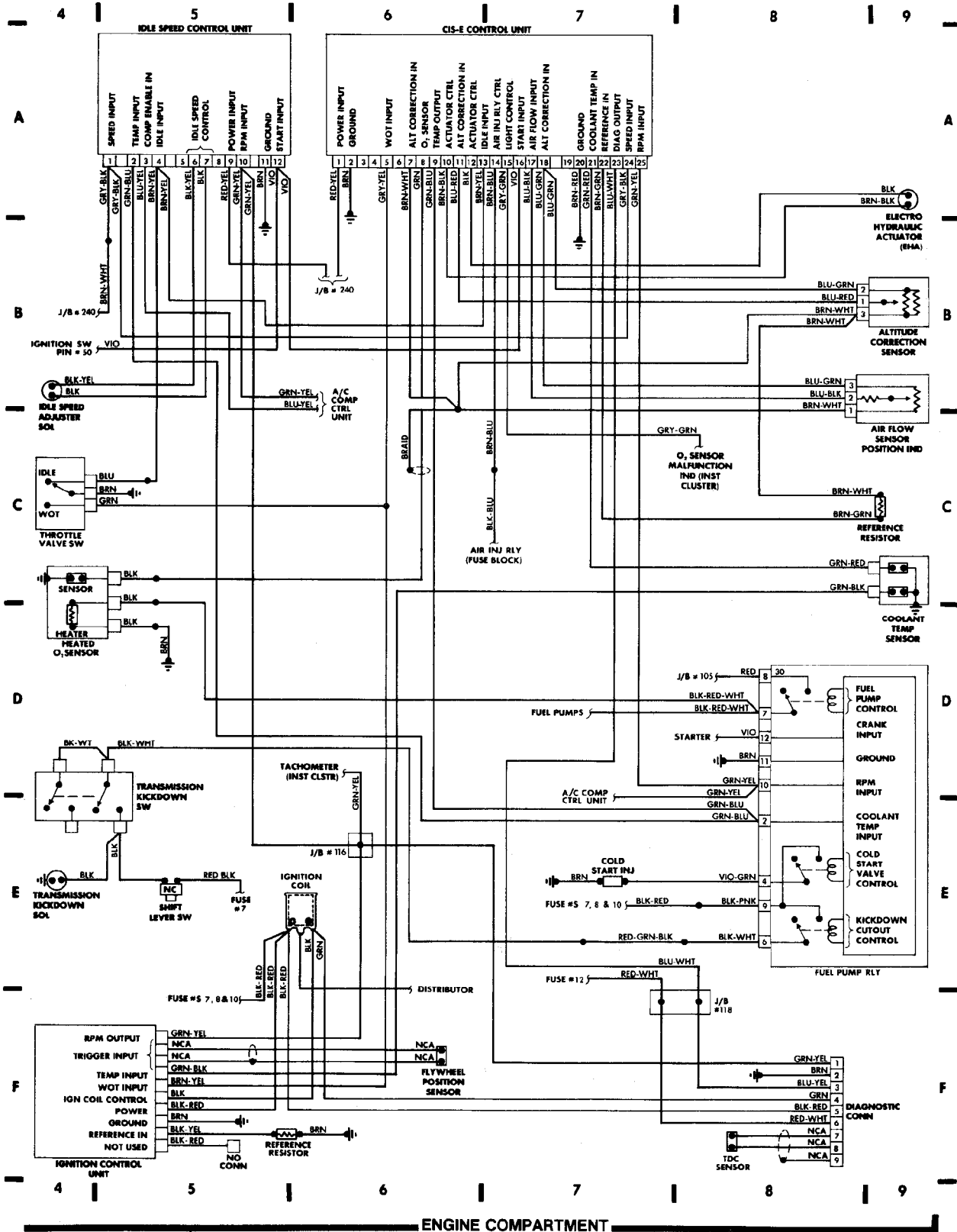

ENGINE COMPARTMENT

# WIRING DIAGRAMS

## Fig. 3: Engine Compartment (Cont.) (Grids 9-14)

### 1987 Mercedes-Benz 560SL

Tuesday, November 28, 2000 01:48PM

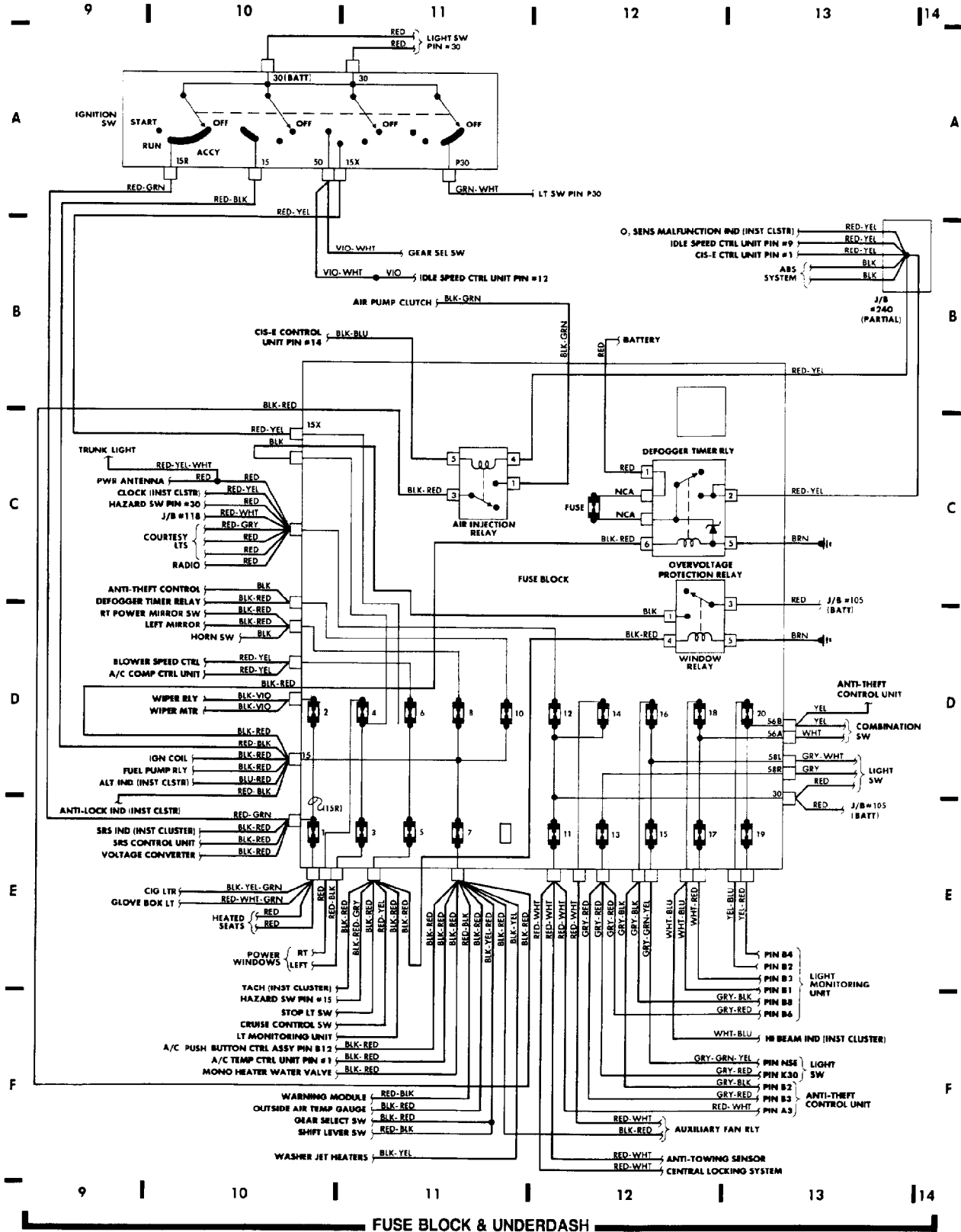

# WIRING DIAGRAMS

## Fig. 4: Underdash (Cont.) (Grids 14-18)

### 1987 Mercedes-Benz 560SL

Tuesday, November 28, 2000 01:48PM

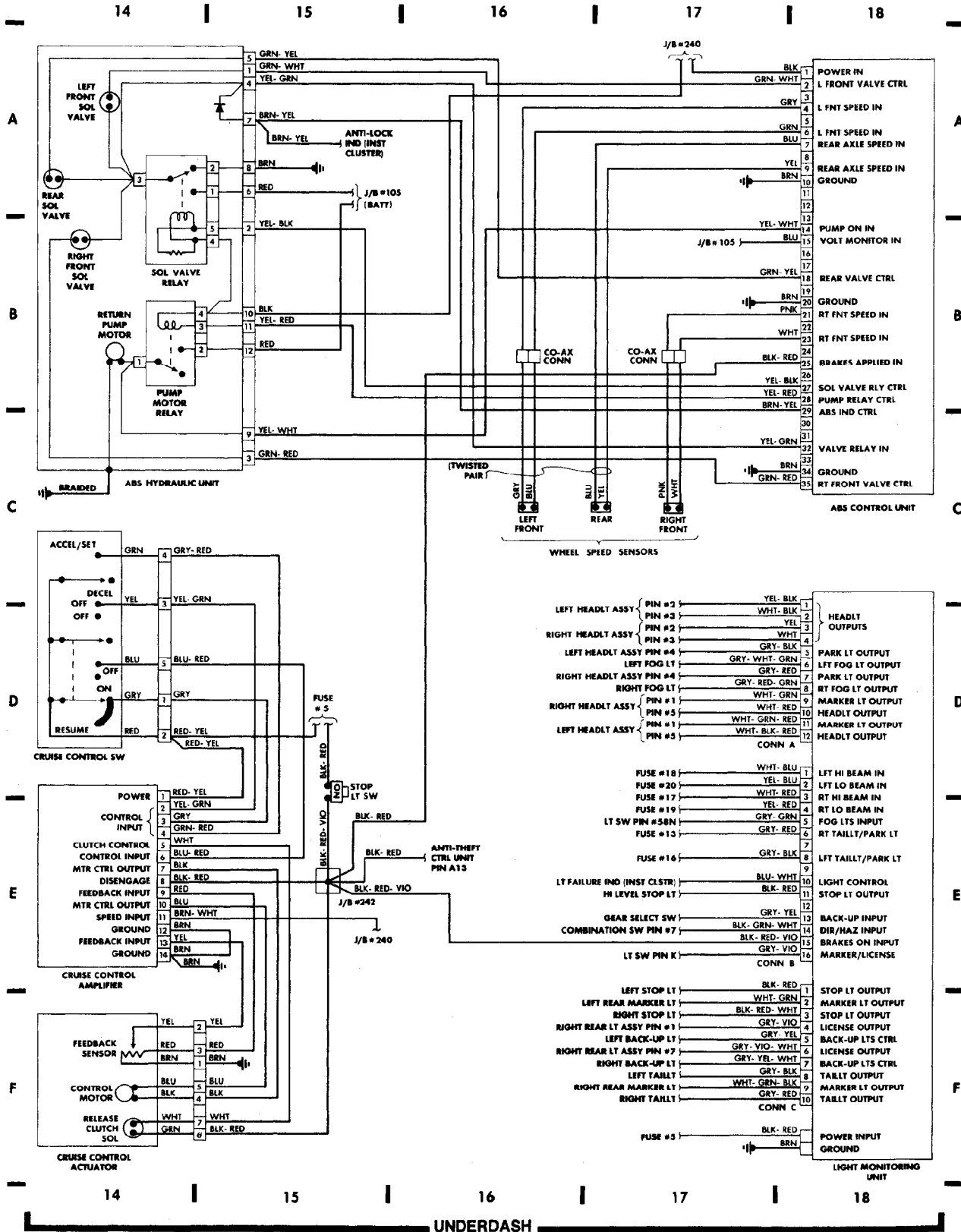

cardiagn.com

# WIRING DIAGRAMS

## Fig. 5: Underdash (Cont.) (Grids 18-23)

### 1987 Mercedes-Benz 560SL

Tuesday, November 28, 2000 01:48PM

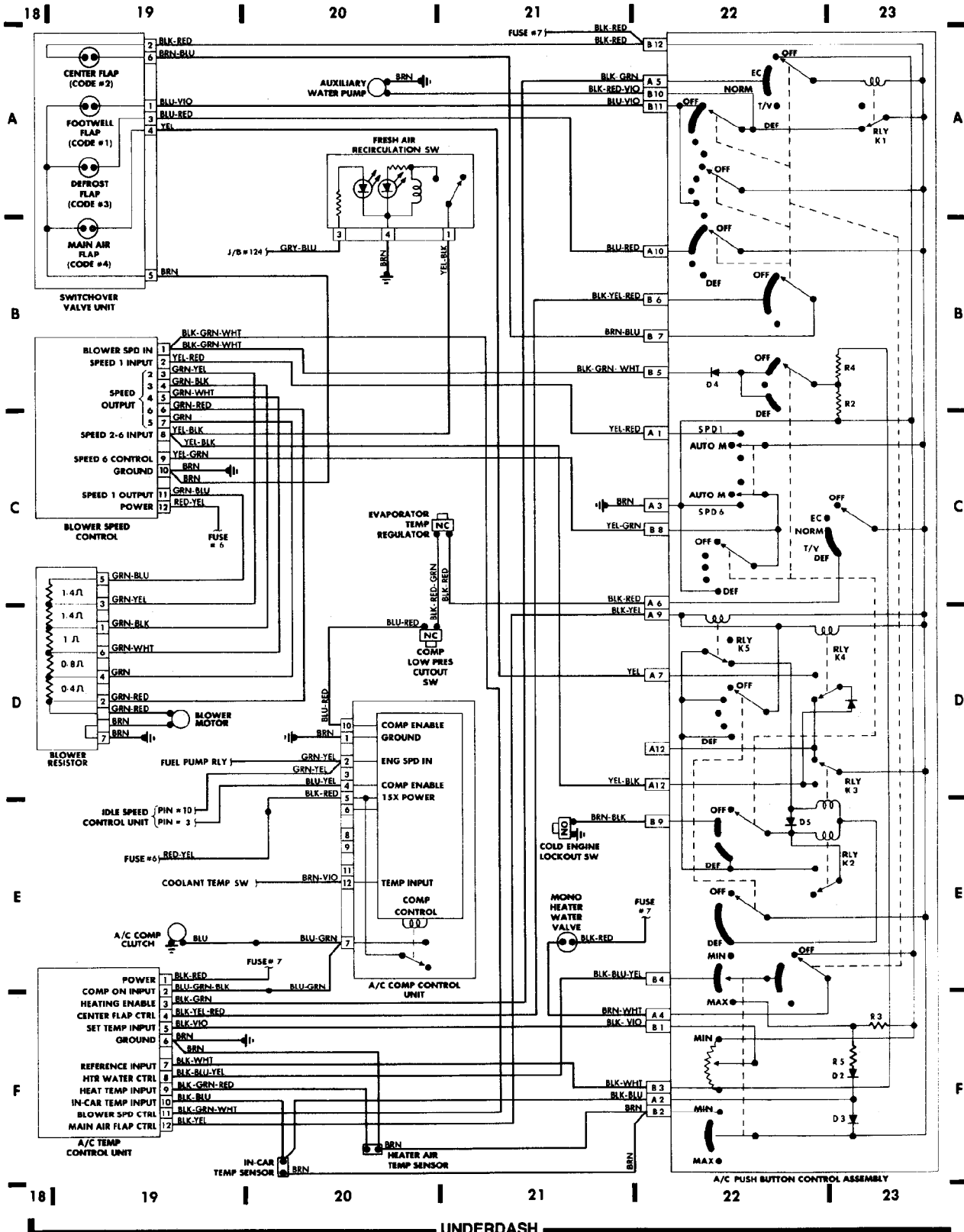

cardiagn.com





# WIRING DIAGRAMS

## Fig. 8: Rear Compartment & Accessories (Grids 33-37)

### 1987 Mercedes-Benz 560SL

Tuesday, November 28, 2000 01:50PM

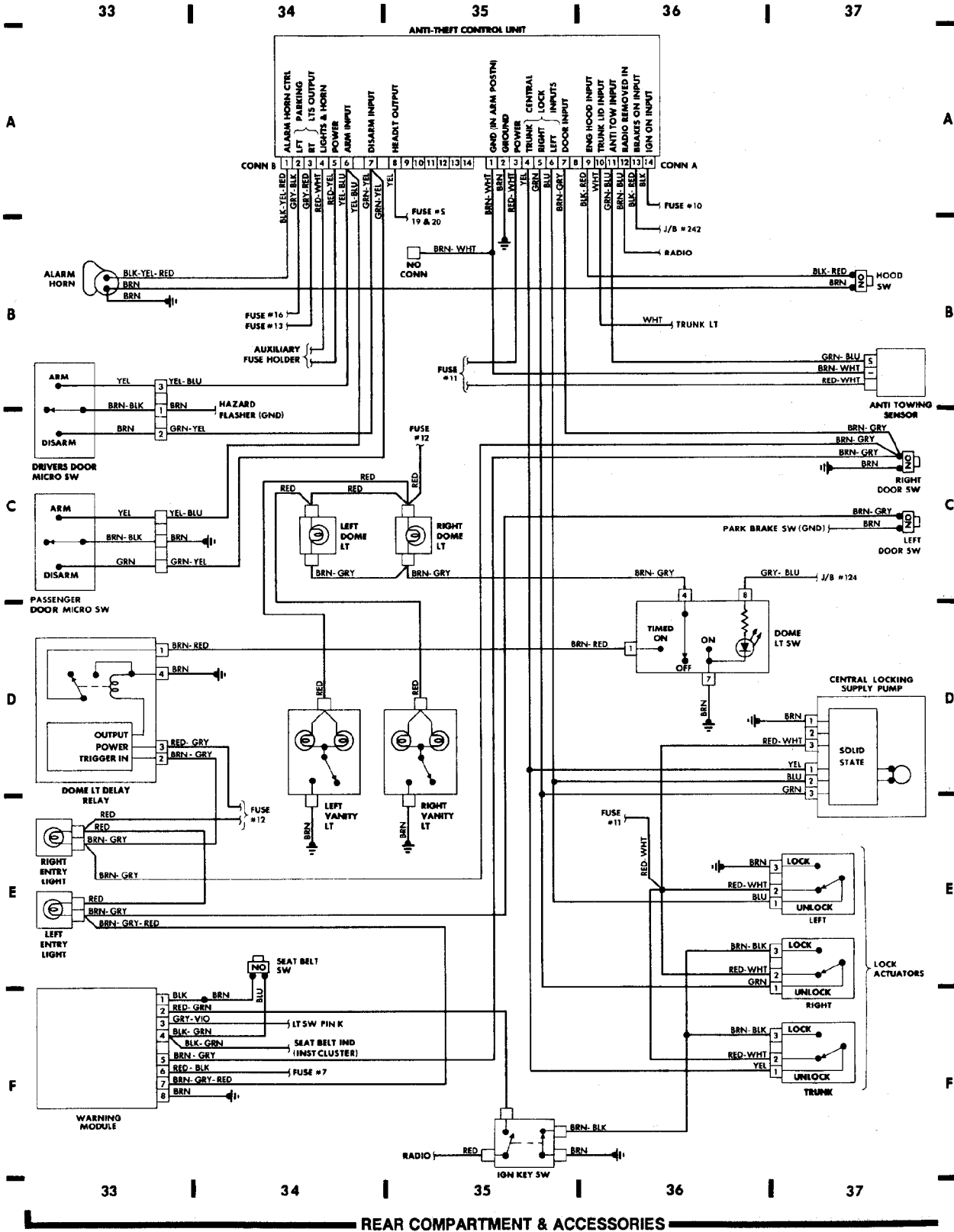

# WIRING DIAGRAMS

## Fig. 9: Rear Compartment & Accessories (Cont.) (Grids 37-42)

1987 Mercedes-Benz 560SL

Tuesday, November 28, 2000 01:50PM

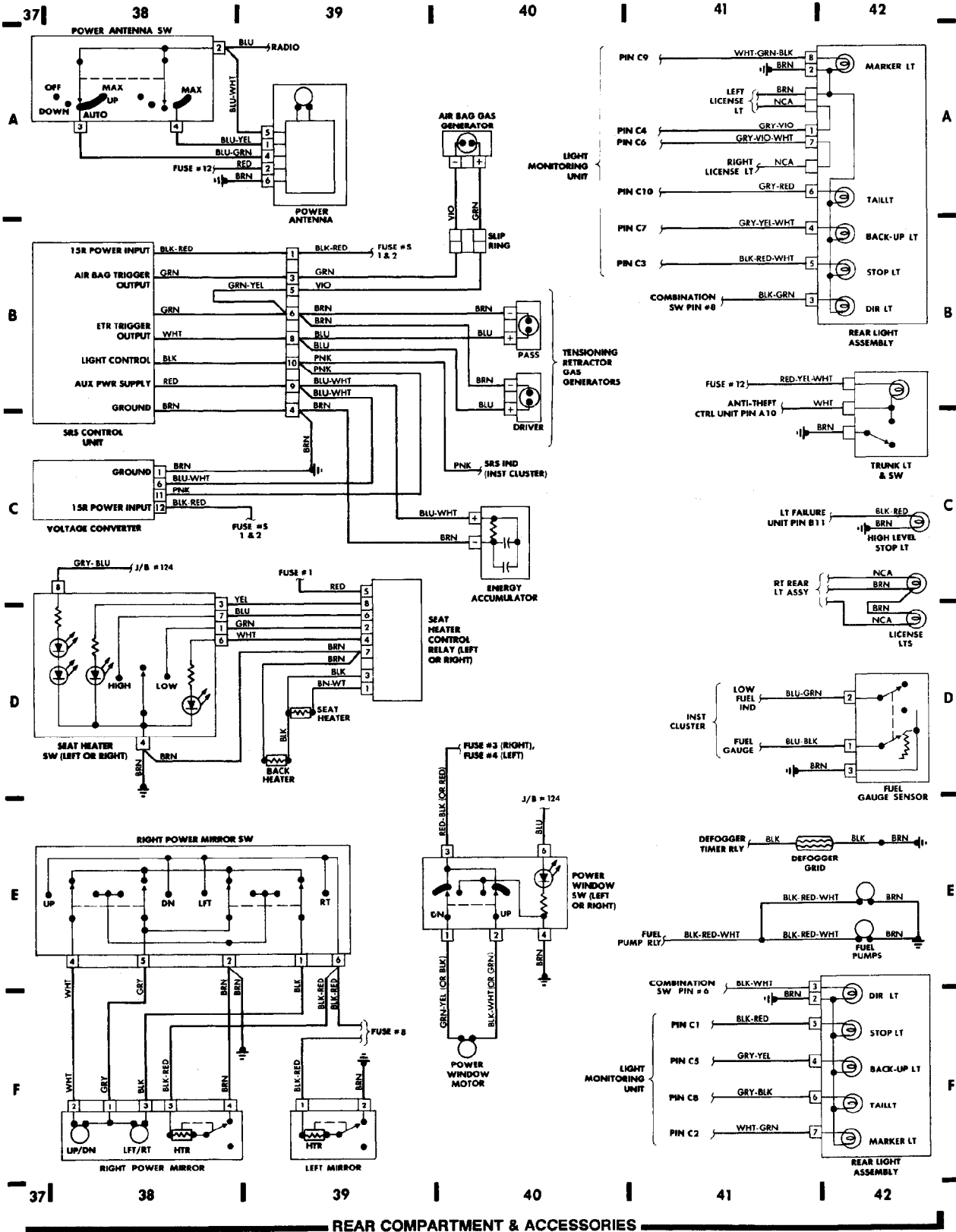

REAR COMPARTMENT & ACCESSORIES