

WIRING DIAGRAMS

Fig. 1: Engine Compartment (Grids 1-3)

1987 Mercedes-Benz 190E

Tuesday, November 28, 2000 12:27PM

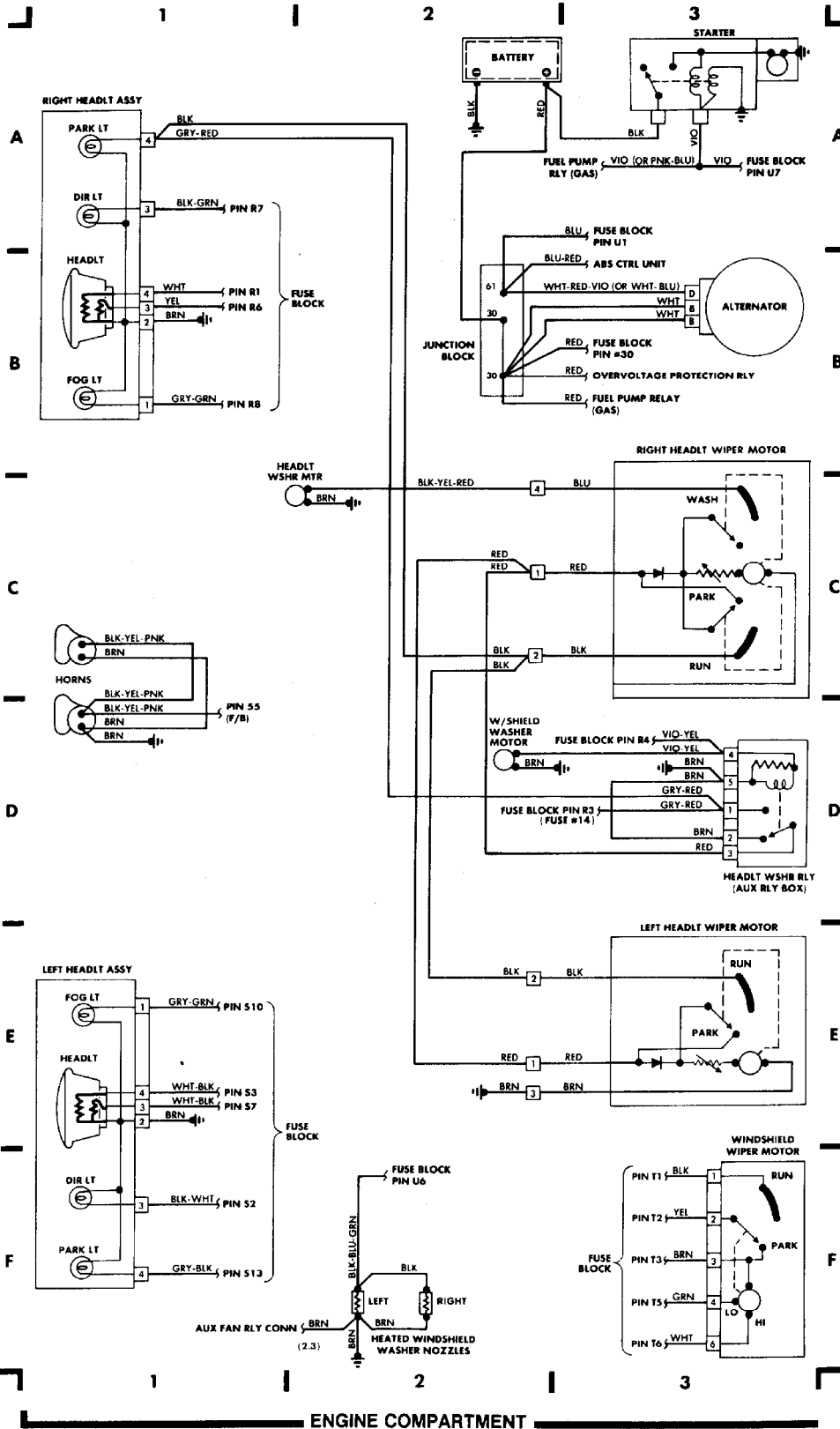

cardiagn.com

WIRING DIAGRAMS

Fig. 2: Engine Compartment (Cont.) (Grids 4-7)

1987 Mercedes-Benz 190E

Tuesday, November 28, 2000 12:28PM

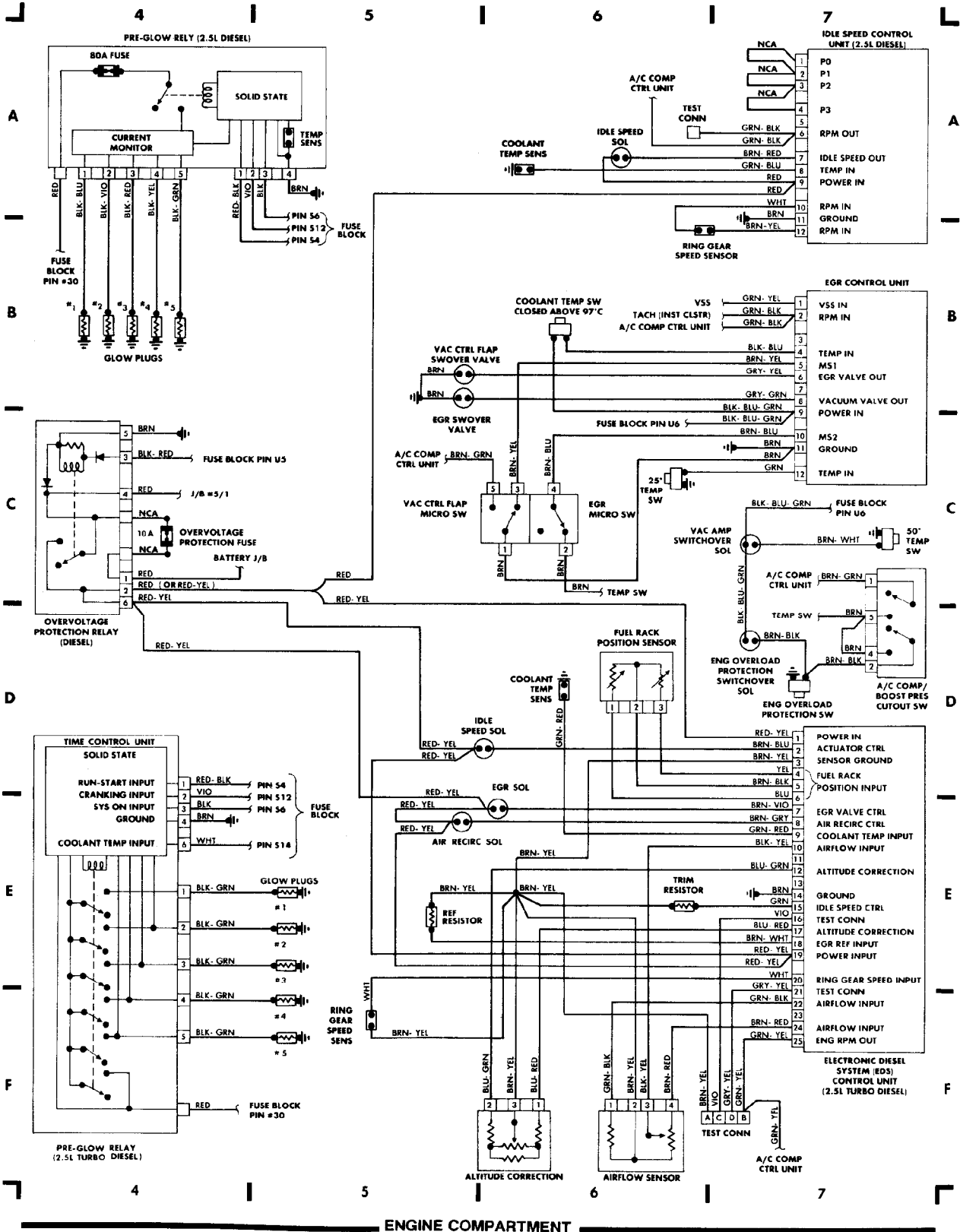

ENGINE COMPARTMENT

WIRING DIAGRAMS

Fig. 3: Engine Compartment (Cont.) (Grids 8-11)

1987 Mercedes-Benz 190E

Tuesday, November 28, 2000 12:28PM

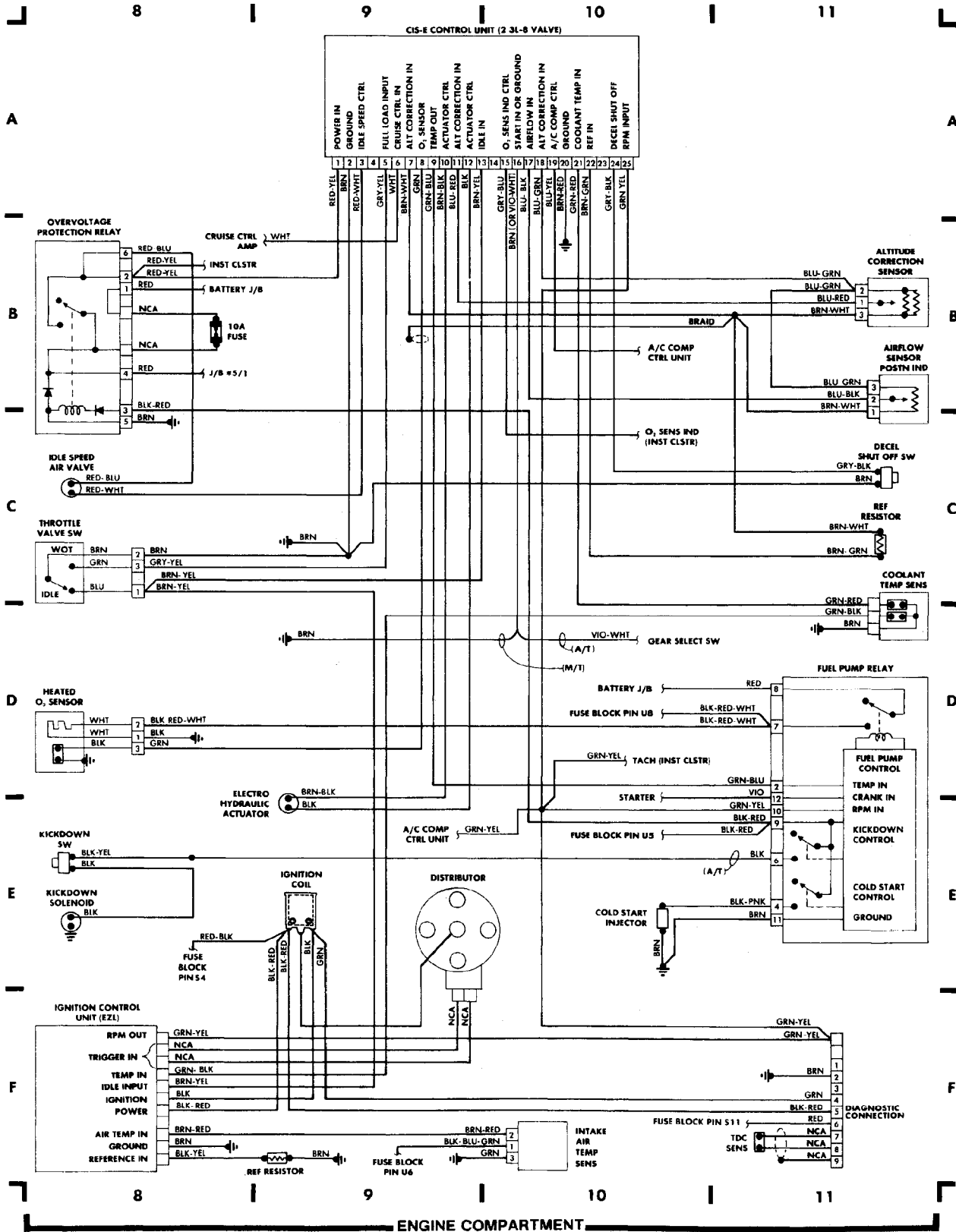

cardiagn.com

WIRING DIAGRAMS

Fig. 4: Engine Compartment (Cont.) (Grids 12-15)

1987 Mercedes-Benz 190E

Tuesday, November 28, 2000 12:28PM

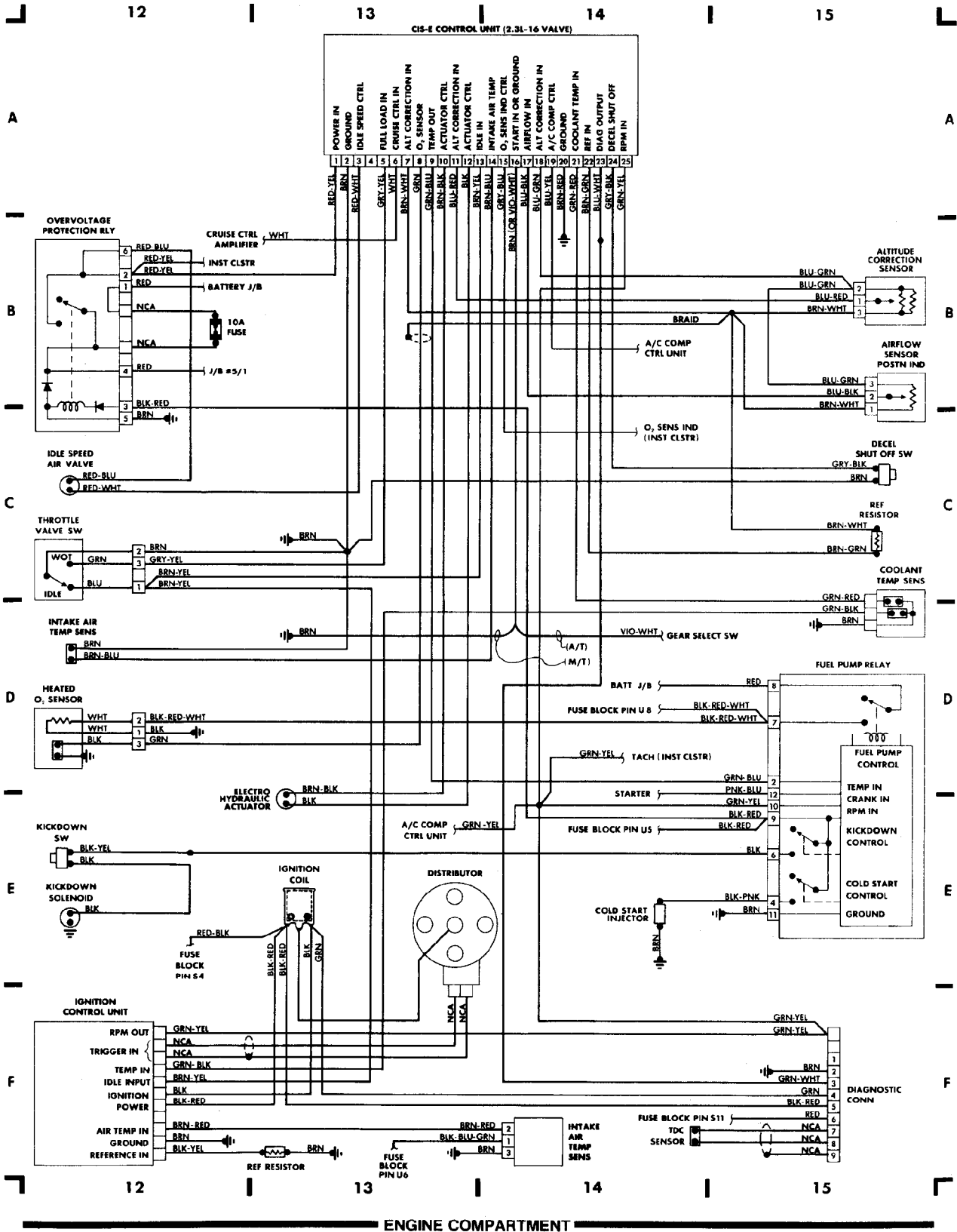

ENGINE COMPARTMENT

WIRING DIAGRAMS

Fig. 5: Engine Compartment (Cont.) (Grids 16-19)

1987 Mercedes-Benz 190E

Tuesday, November 28, 2000 12:29PM

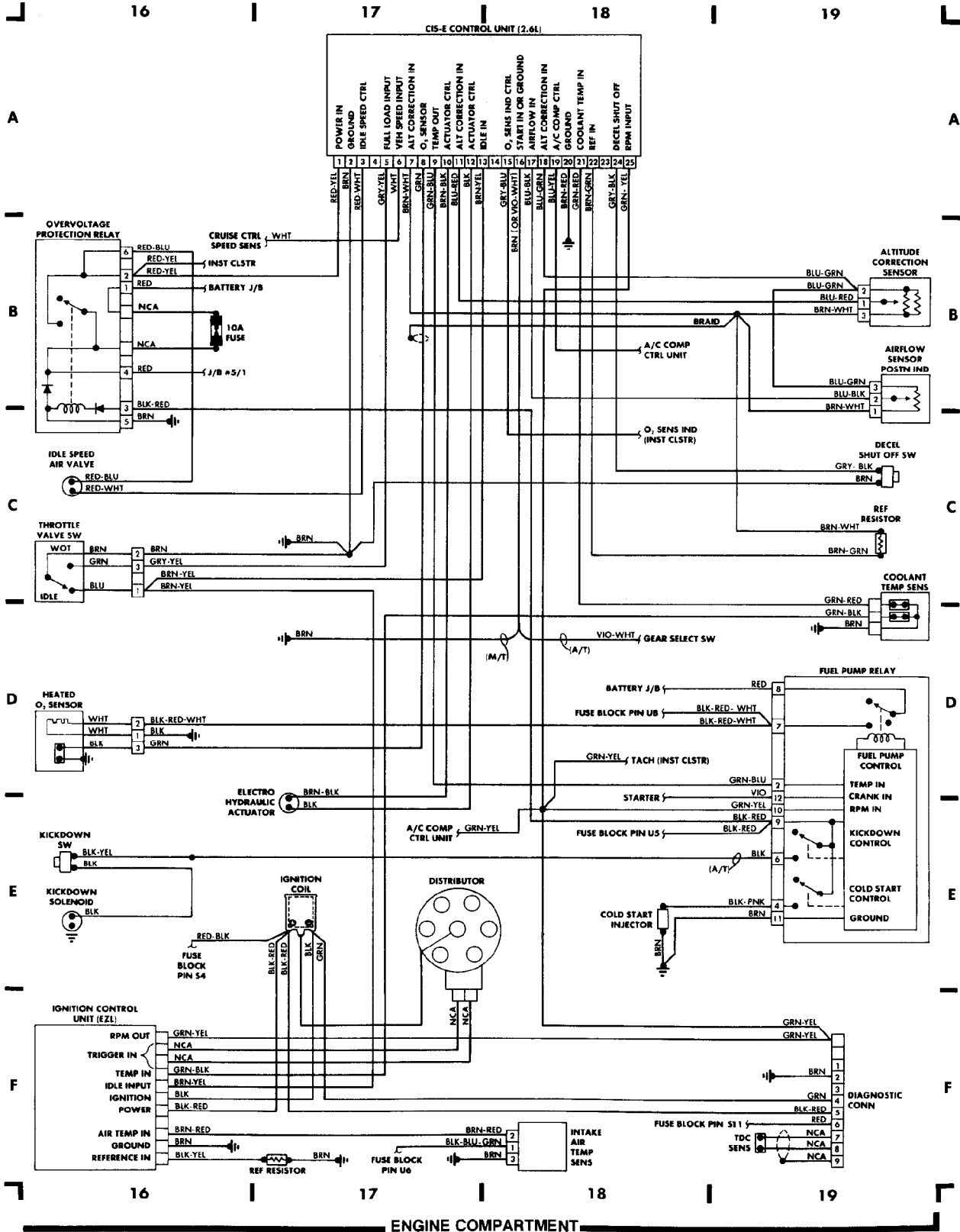

ENGINE COMPARTMENT

WIRING DIAGRAMS

Fig. 6: Fuse Block & Underdash (Grids 20-23)

1987 Mercedes-Benz 190E

Tuesday, November 28, 2000 12:29PM

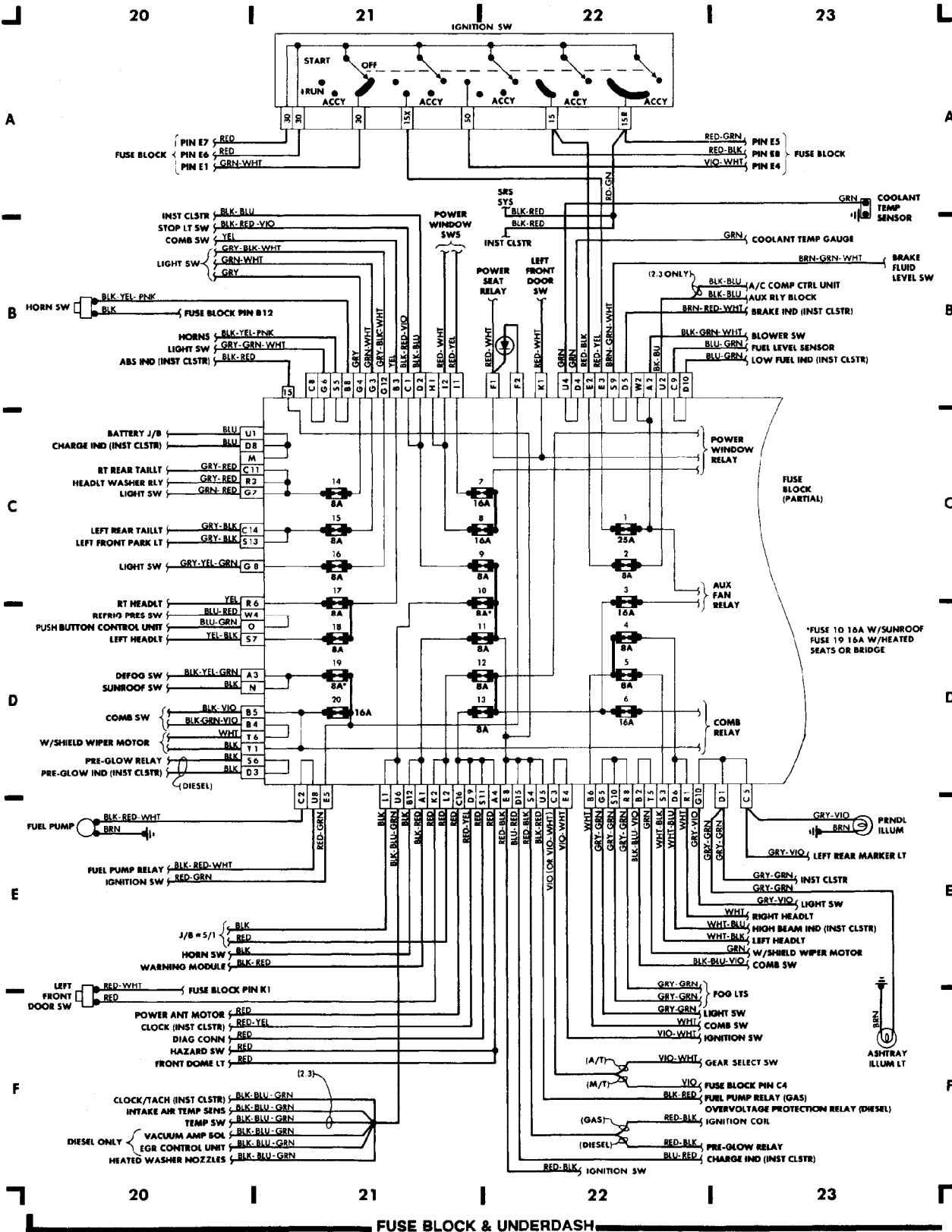

WIRING DIAGRAMS

Fig. 7: Fuse Block & Underdash (Cont.) (Grids 24-27)

1987 Mercedes-Benz 190E

Tuesday, November 28, 2000 12:29PM

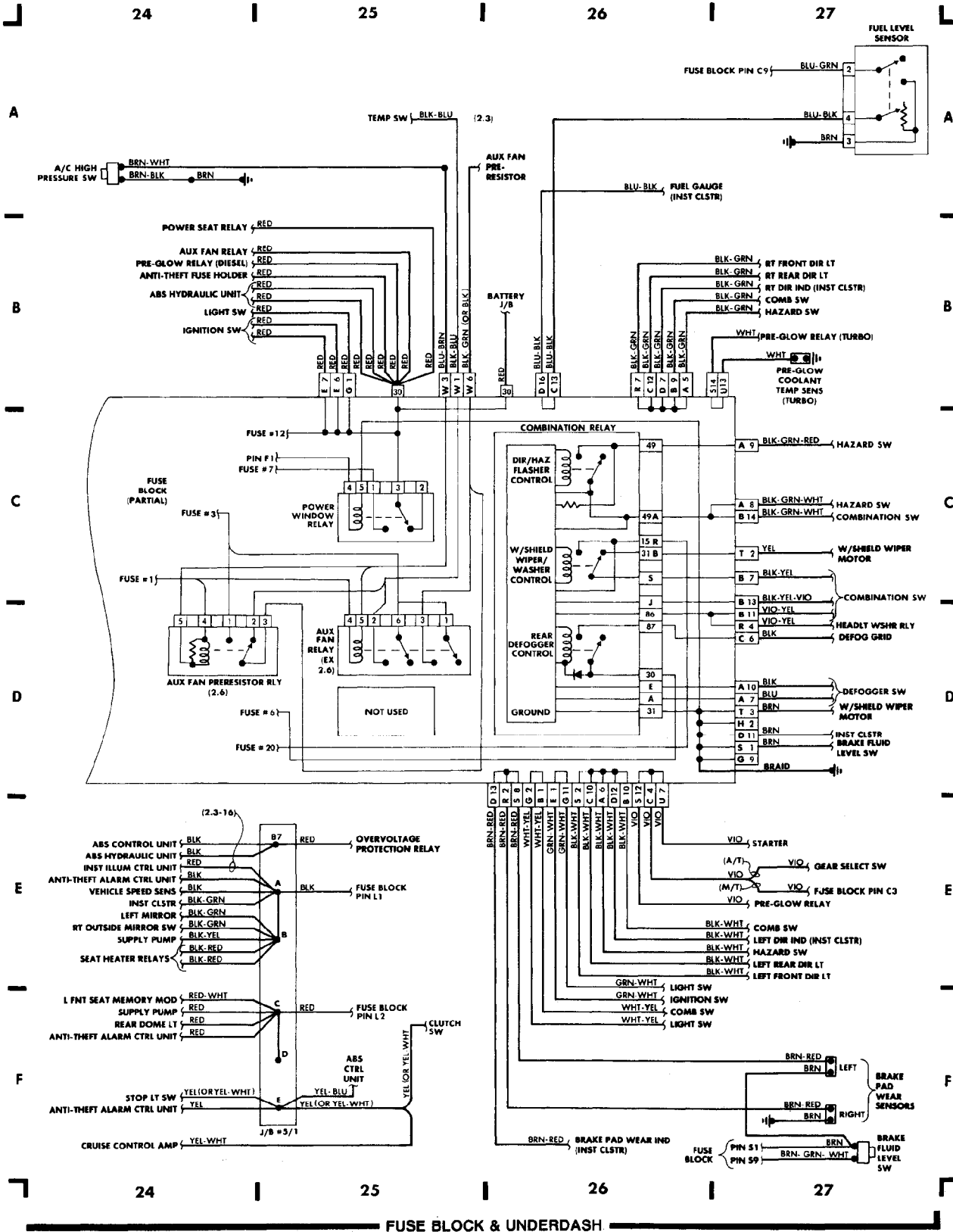

cardiagn.com

WIRING DIAGRAMS

Fig. 8: Underdash (Cont.) (Grids 28-31)

1987 Mercedes-Benz 190E

Tuesday, November 28, 2000 12:29PM

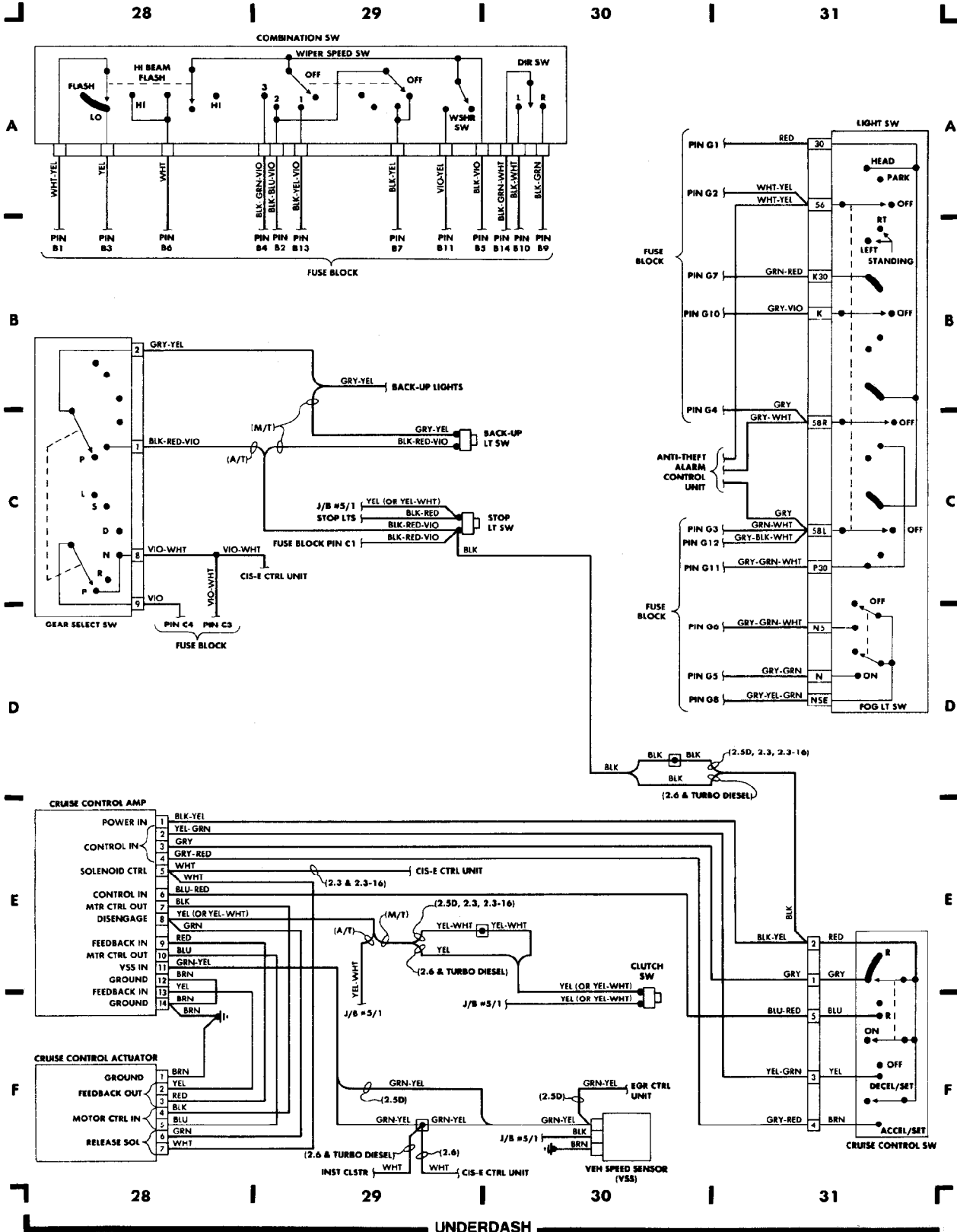

cardiagn.com

WIRING DIAGRAMS

Fig. 9: Underdash (Cont.) (Grids 32-35)

1987 Mercedes-Benz 190E

Tuesday, November 28, 2000 12:30PM

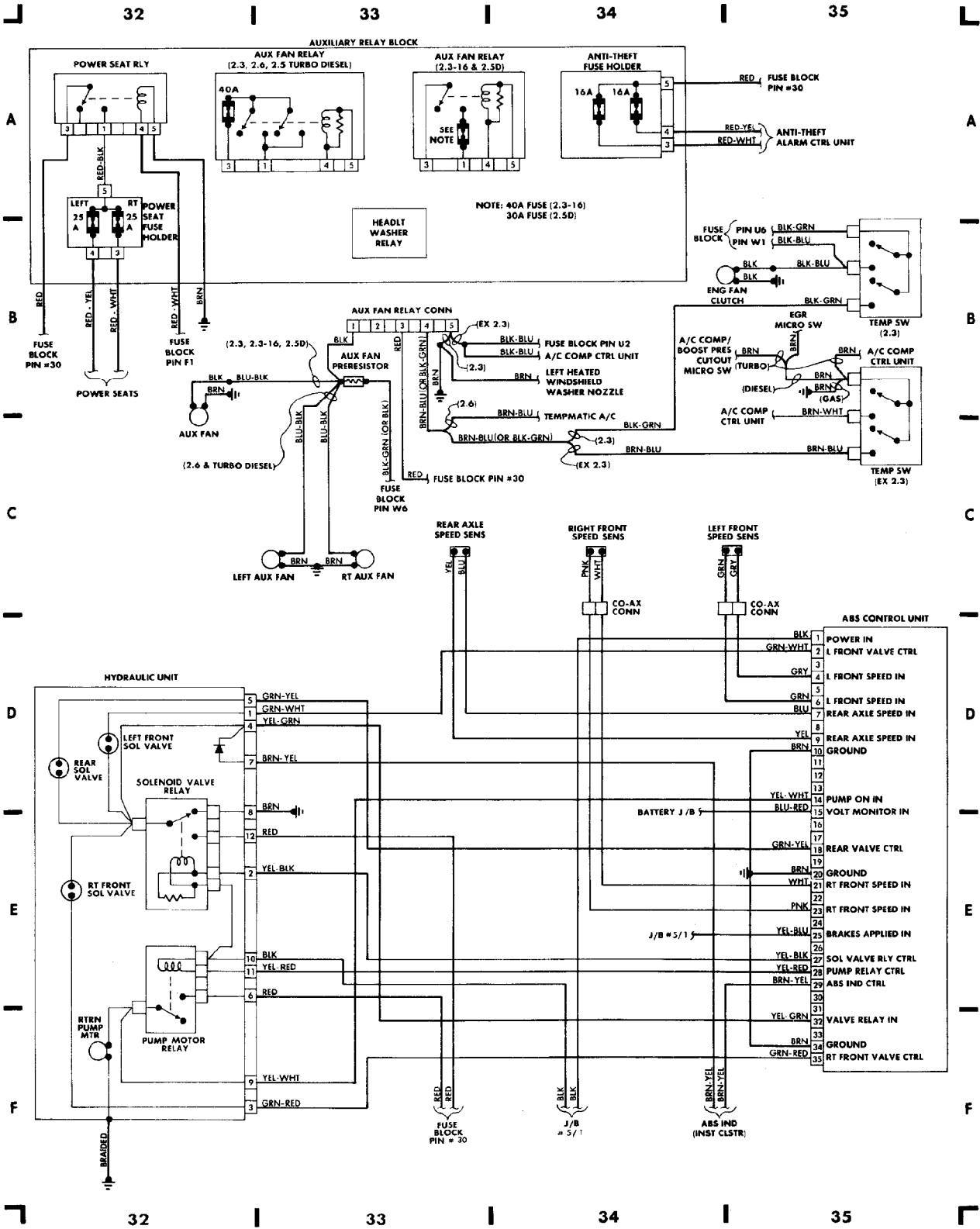

WIRING DIAGRAMS

Fig. 10: Underdash (Cont.) (Grids 36-39)

1987 Mercedes-Benz 190E

Tuesday, November 28, 2000 12:30PM

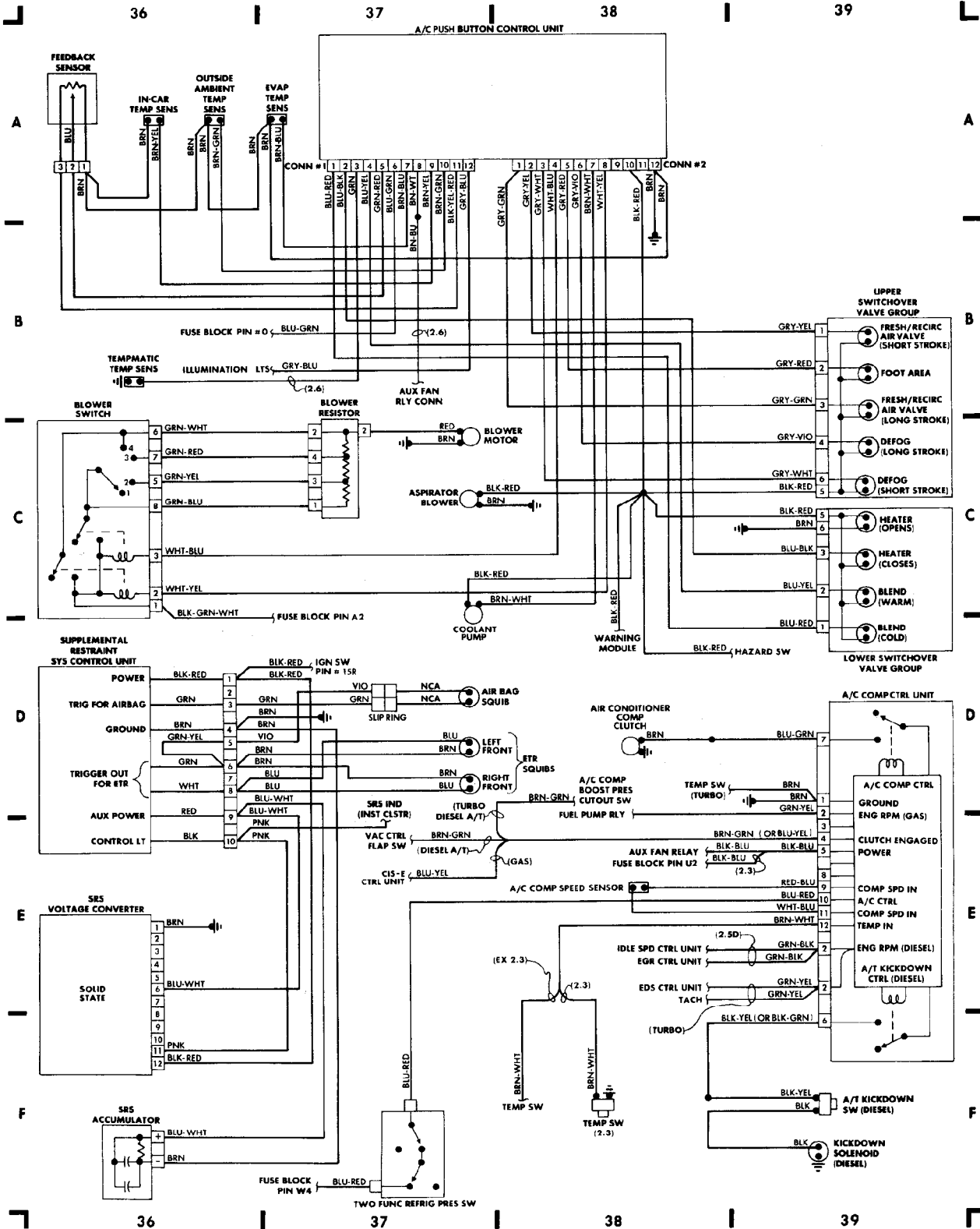

UNDERDASH

WIRING DIAGRAMS

Fig. 11: Underdash (Cont.) & Instrument Panel (Grids 40-43)

1987 Mercedes-Benz 190E

Tuesday, November 28, 2000 12:30PM

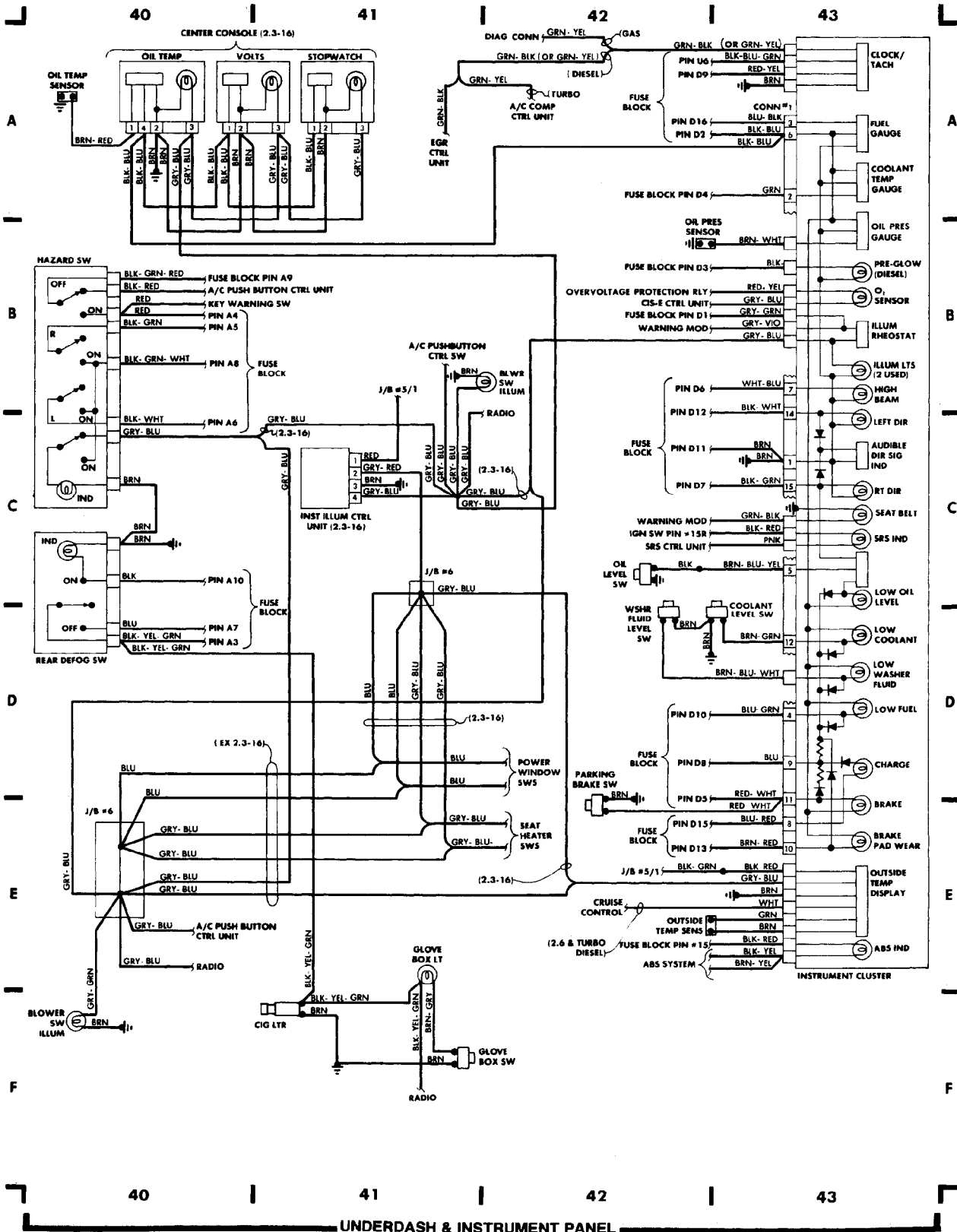

cardiagn.com

WIRING DIAGRAMS

Fig. 12: Rear Compartment & Accessories (Grids 44-47)

1987 Mercedes-Benz 190E

Tuesday, November 28, 2000 12:30PM

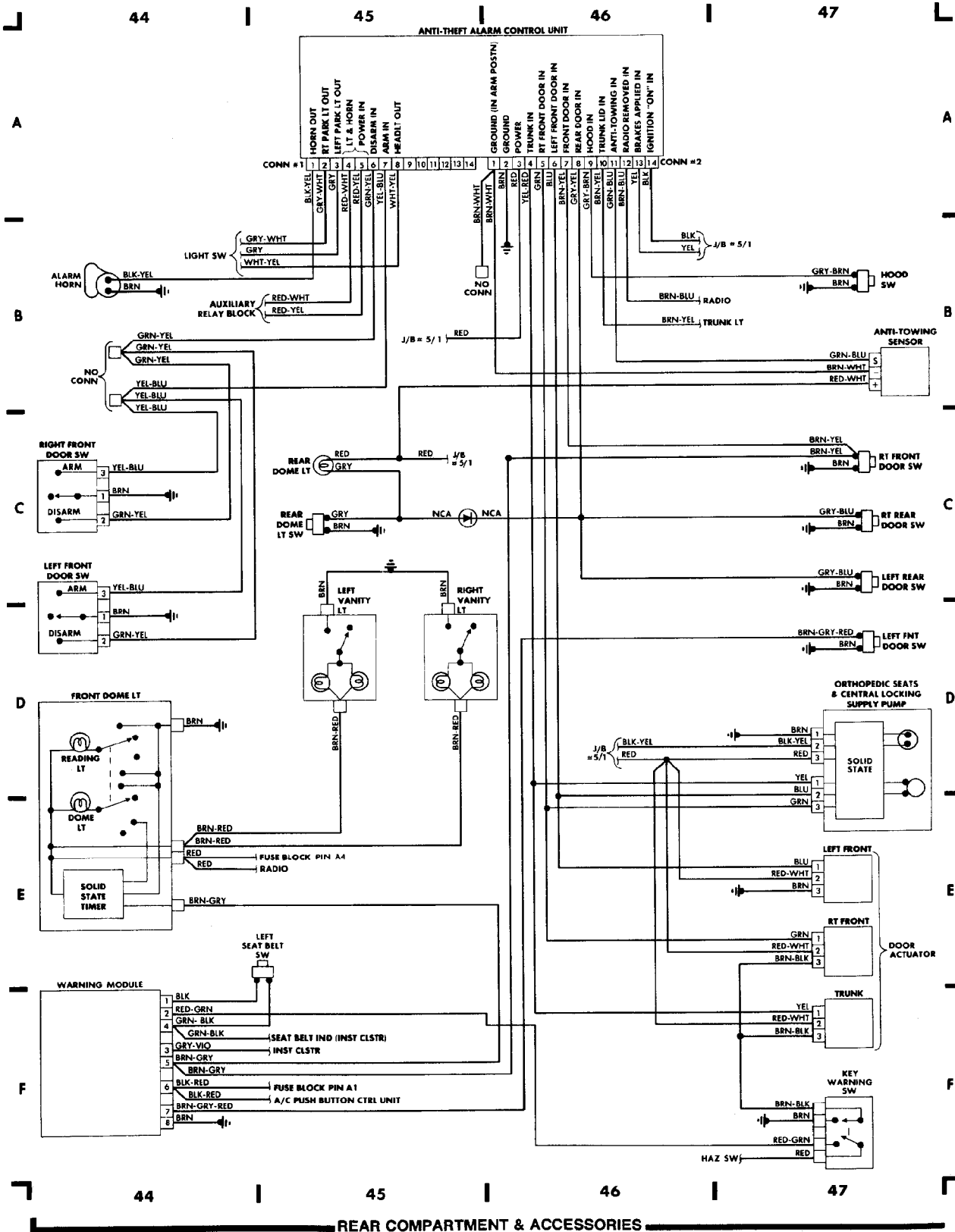

cardiagn.com

WIRING DIAGRAMS

Fig. 13: Rear Compartment & Accessories (Cont.) (Grids 48-51)
1987 Mercedes-Benz 190E

Tuesday, November 28, 2000 12:31PM

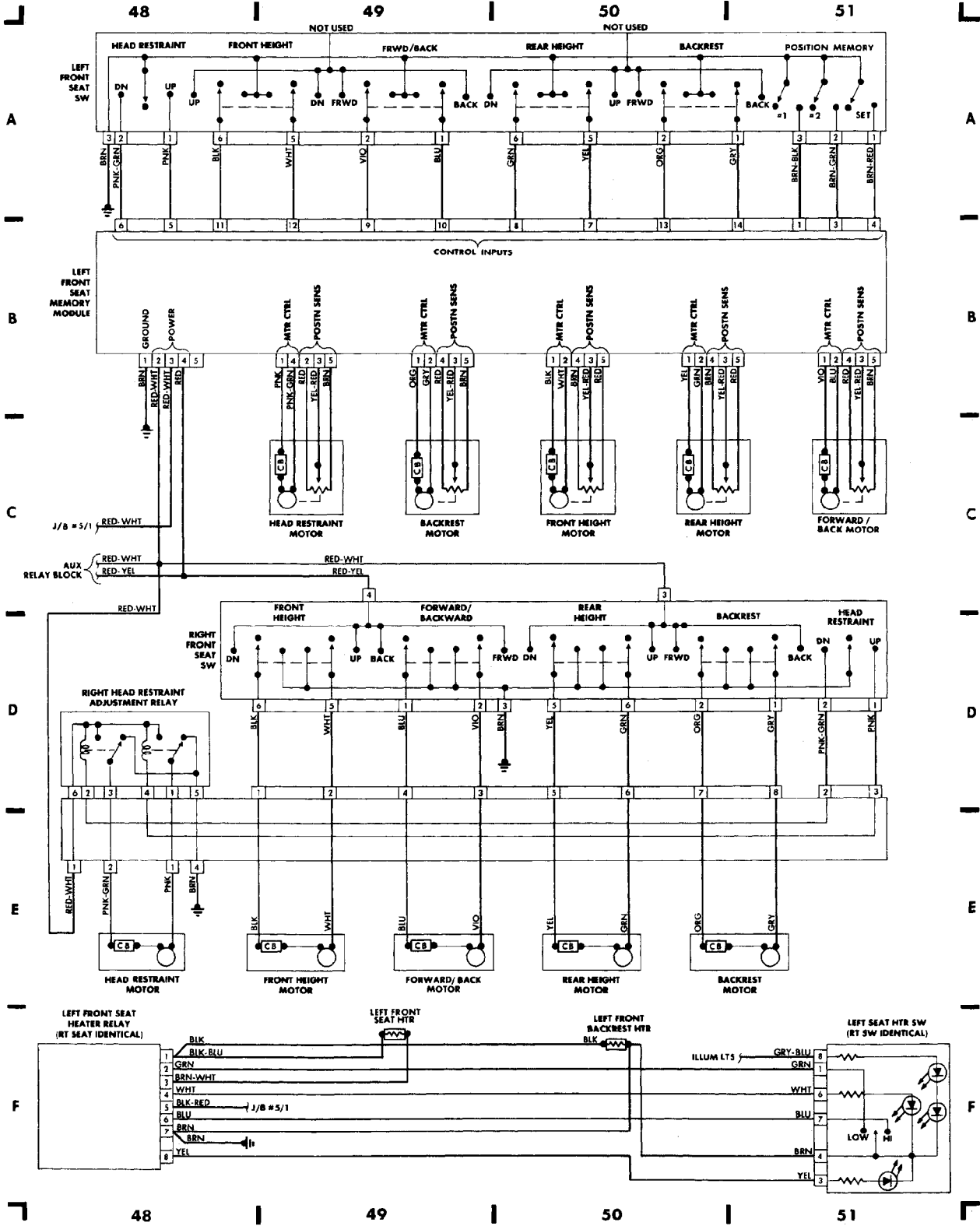

REAR COMPARTMENT & ACCESSORIES

WIRING DIAGRAMS

Fig. 14: Rear Compartment & Accessories (Cont.) (Grids 52-55)

1987 Mercedes-Benz 190E

Tuesday, November 28, 2000 12:31PM

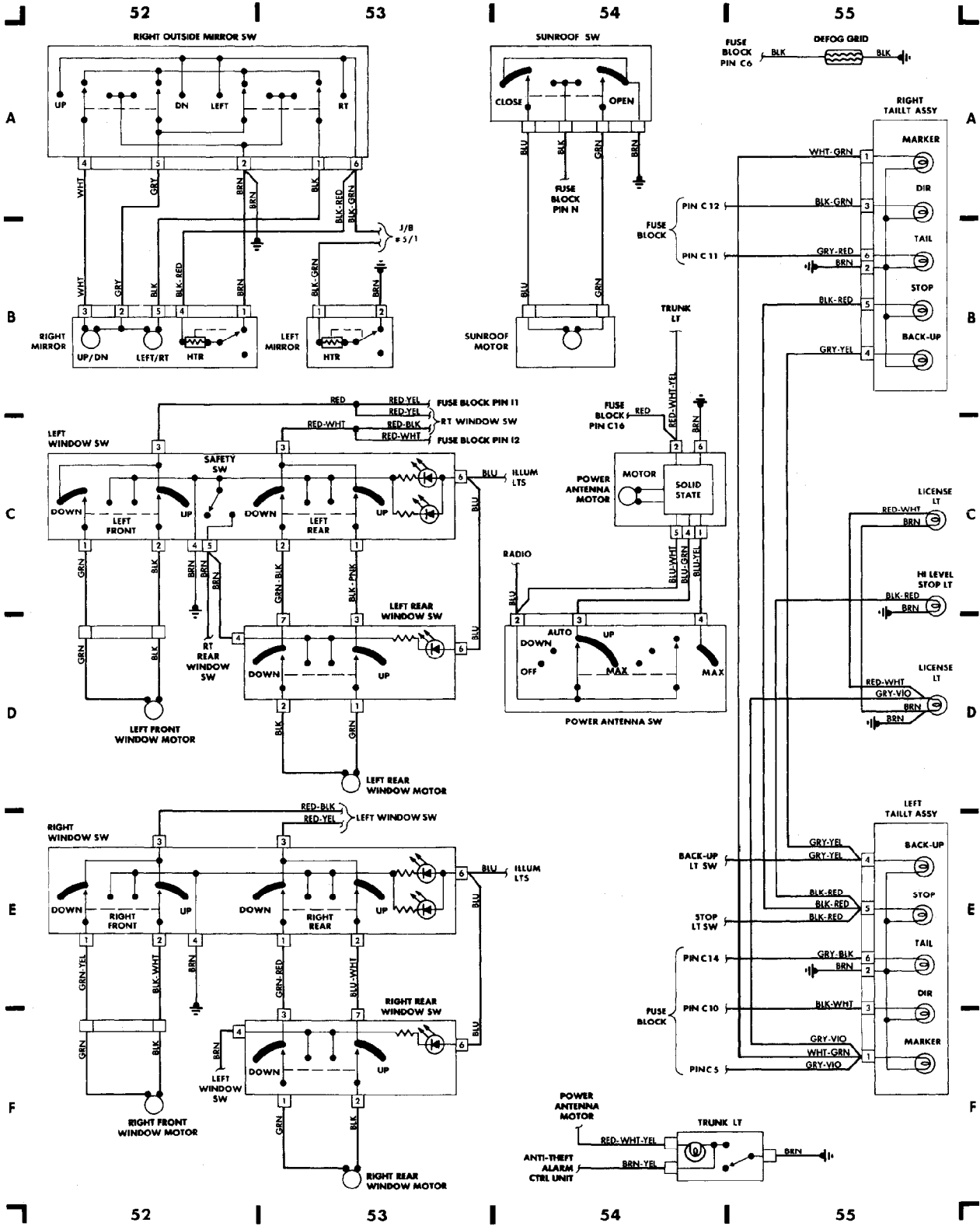

REAR COMPARTMENT & ACCESSORIES